

Assembly
and
Operation
of the



SCANALYZER
MODEL SB-620



TABLE OF CONTENTS

Introduction.	2
Parts List.	3
Step-By-Step Assembly.	6
Panel Parts Mounting.	11
Initial Wiring.	14
Cable Assembly Wiring.	18
Panel and Switch Wiring.	19
Component Installation.	22
Optional IF Wiring.	27
CRT Installation.	34
Knob Installation.	35
Test And Adjustment.	35
Alignment.	38
Connection To Receiver.	50
Final Assembly.	53
Operation.	54
In Case Of Difficulty.	63
Resistance and Voltage Charts (fold-out from Page).	64
Troubleshooting Chart.	65
Specifications.	67
Circuit Description.	69
Replacement Parts Price List.	72
Schematic (fold-out from Page).	75

INTRODUCTION

The Heathkit Model SB-620 Scanalyzer gives a visual display of signal amplitude versus frequency along the calibrated horizontal axis on a high persistence cathode ray tube. Signals within the band being scanned are displayed on the cathode ray tube as a series of inverted V's. These inverted V's are called "pips."

Your Scanalyzer can be operated as a spectrum monitor to scan wide bands of frequencies for the presence of signals or for clear frequencies. The Scanalyzer can also be used as a separate test instrument (in conjunction with an RF signal generator) to provide high resolution signal analysis.

The pips may be presented on the screen with either a linear or a logarithmic scale. Signals that are as far apart as 40 dB (100:1) in amplitude may be viewed simultaneously with a logarithmic presentation. The linear scale will show the actual linear relationship between signals.

Both variable and fixed sweep widths are provided. The variable sweep width mode of operation provides up to 500 kHz of band width presentation (150 kHz maximum when wired for 455 kHz IF systems). The 10 kHz and 50 kHz fixed, narrow-band sweep widths permit slow speed, high resolution signal analysis. At these reduced sweep widths and slow sweep rates, this instrument can resolve equal amplitude signals down to 1 kHz separation.

Because it gives a panoramic presentation when connected to the IF system of a communications receiver, the Scanalyzer is invaluable for monitoring a wide frequency band for the appearance, disappearance, and shift of signals. Yet, when it is placed in the 10 kHz or 50 kHz sweep modes, it enables you to examine signals so closely adjacent in frequency that their corresponding deflections normally tend to merge together or even completely mask one another (see Figures 40-11 and 40-12 on fold-out from Page 63).

With the Scanalyzer, you will be able to visually monitor the portion of the band that is centered around the frequency you have tuned on your receiver. For example, you may see clear frequency areas in a crowded amateur band, or signals that may appear on a seldom used band. It is possible to identify the type of transmissions: SSB, AM, CW, etc. The Scanalyzer can be used to provide a visual check for out-of-band operation (when used in conjunction with a calibrator), to aid in locating spurious transmitter radiation, for carrier null adjustments, and for measuring unwanted sideband.

You may also examine and analyze signals of frequencies other than those for which the Scanalyzer input has been wired by using the input stage as a mixer as described in the Operation section of this Manual. When set up in this manner, the Scanalyzer provides a visual means of examining such things as the intermodulation distortion products of a single sideband signal.

Other features of the Scanalyzer include: Focus and Astigmatism controls for a sharp clear trace, a fast sweep push-button switch for the 10 kHz and 50 kHz preset slow sweep rates, a -20 dB Log switch position for an additional 20 dB of attenuation in the IF system (which permits a full 60 dB dynamic range), plus a 20 dB attenuator switch for the test signal input.

The Scanalyzer can be wired for any receiver IF frequency between 455 kHz and 6 MHz, and it may be used with either a 120 or a 240 VAC, 50/60 Hz power source.

Refer to the "Kit Builders Guide" for complete information on unpacking, parts identification, tools, wiring, soldering, and step-by-step assembly procedures.

PARTS LIST

The numbers in parentheses are keyed to the numbers on the Parts Pictorials (fold-out from Pages 3 through 5) to aid in parts identification.

To order replacement parts, refer to the Replacement Parts Price List and use the Parts Order Form furnished with this kit.

PART No.	PARTS Per Kit	DESCRIPTION
----------	---------------	-------------

RESISTORS

1/2 Watt

(1)1-62	2	51 Ω (green-brown-black)
1-84	3	62 Ω (blue-red-black)
1-3	2	100 Ω (brown-black-brown)
1-6	1	470 Ω (yellow-violet-brown)
1-63	2	510 Ω (green-brown-brown)
1-9	3	1000 Ω (brown-black-red)
1-93	1	1800 Ω (brown-gray-red)
1-13	1	2700 Ω (red-violet-red)
1-14	2	3300 Ω (orange-orange-red)
1-16	1	4700 Ω (yellow-violet-red)
1-20	6	10 K Ω (brown-black-orange)
1-21	2	15 K Ω (brown-green-orange)
1-22	2	22 K Ω (red-red-orange)
1-24	1	33 K Ω (orange-orange-orange)
1-25	5	47 K Ω (yellow-violet-orange)
1-60	1	68 K Ω (blue-gray-orange)
1-26	4	100 K Ω (brown-black-yellow)
1-27	1	150 K Ω (brown-green-yellow)
1-29	5	220 K Ω (red-red-yellow)
1-31	2	330 K Ω (orange-orange-yellow)
1-33	2	470 K Ω (yellow-violet-yellow)
1-68	1	820 K Ω (gray-red-yellow)
1-36	2	1.5 megohm (brown-green-green)
1-38	3	3.3 megohm (orange-orange-green)
1-71	1	4.7 megohm (yellow-violet-green)
1-86	3	5.6 megohm (green-blue-green)
1-40	3	10 megohm (brown-black-blue)

PART No.	PARTS Per Kit	DESCRIPTION
----------	---------------	-------------

Resistors-1/2 Watt (cont'd.)

1-74	1	18 megohm (brown-gray-blue)
1-70	2	22 megohm (red-red-blue)
1-139	1	100 megohm (brown-black-violet)
Other		
(2)1-2-1	1	1000 Ω 1 watt (brown-black-red)
1-27-1	1	33 K Ω 1 watt (orange-orange-orange)
(3)1-15-2	1	1000 Ω 2 watt (brown-black-red)
1-3-2	1	10 K Ω 2 watt (brown-black-orange)
1-18-2	1	33 K Ω 2 watt (orange-orange-orange)
1-5-2	1	220 K Ω 2 watt (red-red-yellow)

CAPACITORS

Resin and Mica

(4)20-52	1	7.5 pf
20-130	1	12 pf
20-124	1	115 pf
20-104	2	130 pf
20-107	1	680 pf
20-137	1	1800 pf
(5)20-42	1	510 pf mica

Disc

(6)21-78	2	5 pf
21-121	1	56 pf
21-54	1	75 pf
21-9	2	100 pf
21-56	6	470 pf
21-27	1	.005 μ fd
21-31	19	.02 μ fd

PARTS PICTORIAL

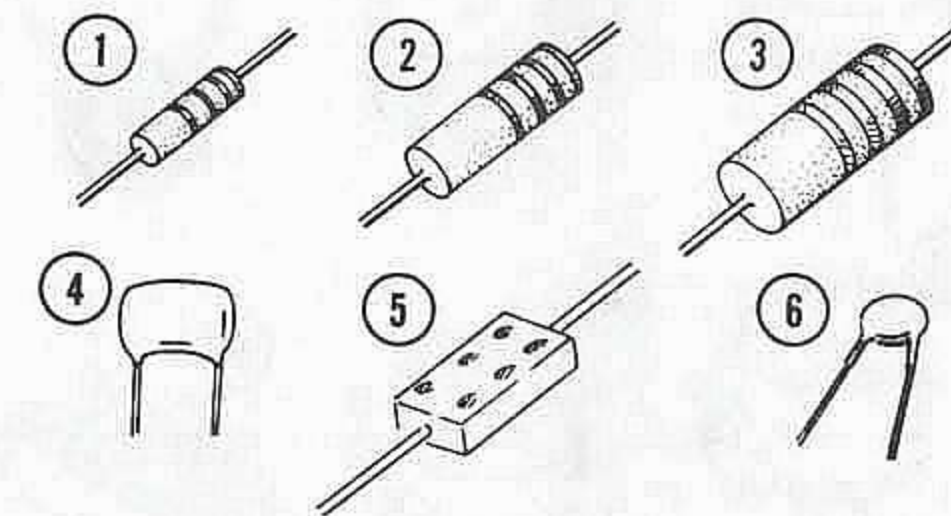

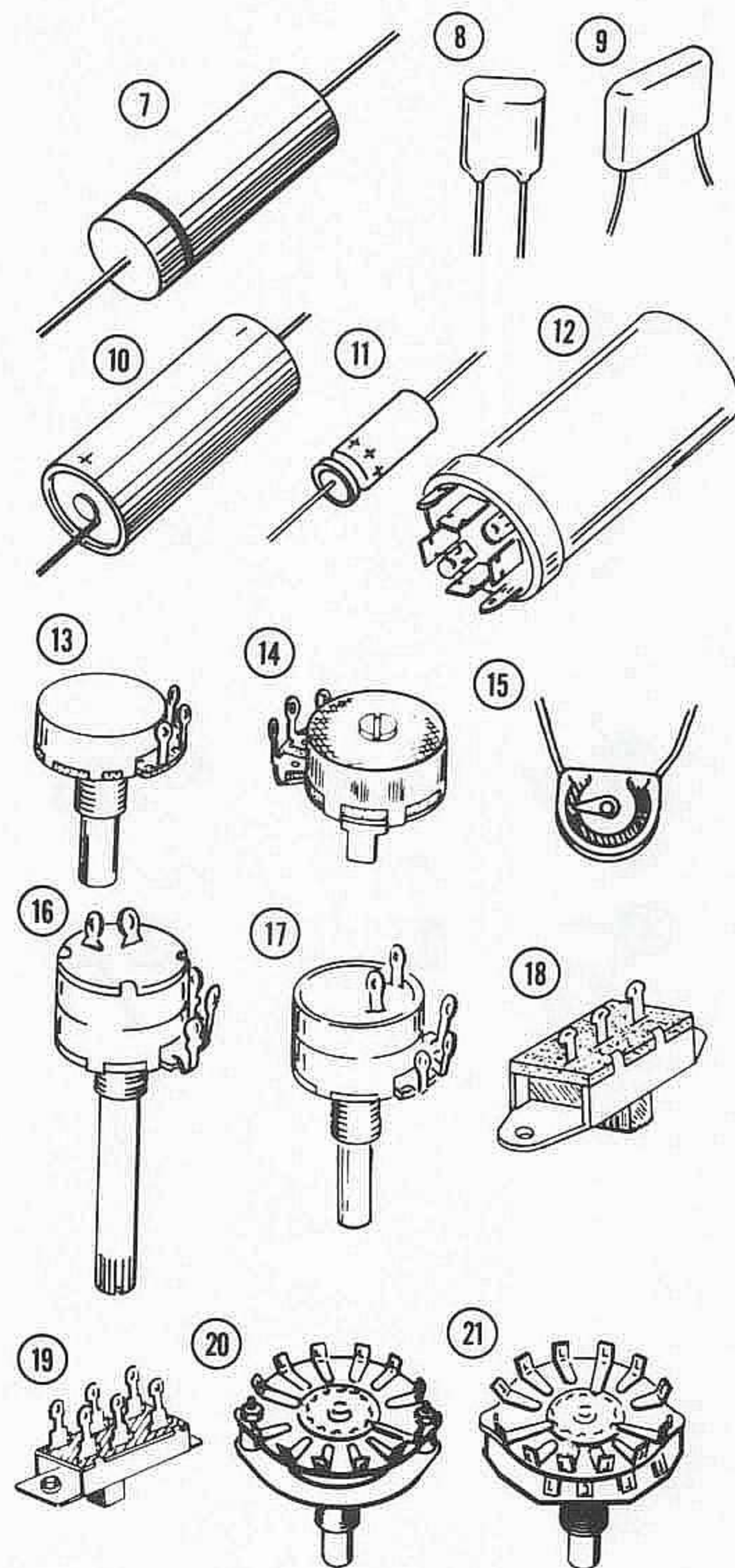

PART No.	PARTS Per Kit	DESCRIPTION	PART No.	PARTS Per Kit	DESCRIPTION
Tubular-Resin			TERMINAL STRIPS		
(7) 23-29	2	.1 μ fd tubular, 1200 VDC	(27) 431-57	1	2-lug
23-94	1	.15 μ fd tubular, 1600 VDC	(28) 431-32	4	2-lug
(8) 27-47	1	.1 μ fd resin	(29) 431-10	2	3-lug
(9) 27-60	1	.22 μ fd resin	(30) 431-12	3	4-lug
27-71	1	1 μ fd resin	(31) 431-40	1	4-lug
Electrolytic			(32) 431-45	1	6-lug
(10) 25-94	1	10 μ fd	(33) 431-55	2	6-lug
25-41	2	40 μ fd	(34) 431-44	1	4-lug high voltage type
(11) 25-56	1	100 μ fd	(35) 431-42	2	5-lug high voltage type
25-154	1	2500 μ fd			
(12) 25-93	1	60-40-20-20 μ fd			
CONTROLS			SOCKETS		
(13) 10-42	2	5000 Ω	(36) 434-34	4	7-pin tube socket
10-32	1	1 megohm	(37) 434-56	2	9-pin tube socket
10-94	2	7.5 megohm	(38) 434-42	2	Phono socket
(14) 10-58	1	100 K Ω twist-tab	(39) 434-74	2	Crystal socket
10-127	2	1 megohm twist-tab	(40) 434-159	1	CRT socket
10-115	1	7.5 megohm twist-tab			
(15) 10-166	1	100 K Ω with wire leads			
(16) 19-78	1	500 K Ω with snap switch			
(17) 19-80	1	500 K Ω with push switch			
SWITCHES			HARDWARE		
			#8 Hardware		
(18) 60-4	1	SPDT slide switch	(41) 250-137	4	8-32 x 3/8" screw
(19) 60-15	1	DPDT slide switch	(42) 250-43	9	8-32 x 1/4" setscrew
(20) 63-336	1	3-position, 3-pole single-wafer switch	(43) 252-4	4	8-32 nut
(21) 63-439	1	3-position, 4-pole, single-wafer switch	(44) 254-2	8	#8 lockwasher
			#6 Hardware		
			(45) 250-40	2	6-32 x 1-1/2" screw
			(46) 250-29	4	6-32 x 3/4" screw
			(47) 250-250	4	6-32 x 1/2" screw (black)
			(48) 250-89	7	6-32 x 3/8" screw
			(49) 250-56	16	6-32 x 1/4" screw
			(50) 252-3	19	6-32 nut
			(51) 253-60	4	#6 flat washer
			(52) 254-1	36	#6 lockwasher
			(53) 259-1	1	Large #6 solder lug
			(54) 259-6	3	Small #6 solder lug
			#3 Hardware		
			(55) 250-172	2	3-48 x 3/8" screw
			(56) 250-49	12	3-48 x 1/4" screw
			(57) 252-1	14	3-48 nut
			(58) 254-7	18	#3 lockwasher
COILS-TRANSFORMERS					
(22) 40-590	2	350 kHz trap coil			
40-775	1	Oscillator coil			
40-776	1	Oscillator coil			
40-808	1	Oscillator coil			
40-807	1	Oscillator coil			
(23) 45-33	1	305 μ H peaking coil			
(24) 52-95	1	IF input transformer			
52-96	1	IF coupling transformer			
52-100	1	IF output transformer			
(25) 52-101	1	Bandpass coupling transformer			
(26) 54-182	1	Power transformer			

PART No. PARTS Per Kit DESCRIPTION

Control Hardware

(59)252-7	9	Control nut
(60)253-10	9	Control flat washer
(61)254-4	2	Thick control lockwasher
(62)254-5	6	Thin control lockwasher
(63)259-10	2	Control solder lug
(64)455-9	1	Brass bushing

Other Hardware

(65)252-9	1	Speednut, large
252-10	2	Speednut, small
(66)255-55	1	3/4" long, tapped phenolic spacer
(67)255-63	2	2" tapped spacer
(68)260-7	3	Transformer mounting clip
(69)260-29	2	Crystal clip

METAL PARTS

(70)100-329	1	CRT mounting ring
(71)207-1	2	CRT neck clamp
(72)210-31	1	Bezel
(73)203-448-3	1	Front Panel
(74)200-471-2	1	Chassis
(75)90-337	1	Cabinet

DIODES-CRYSTALS-TUBES-LAMP

(76)56-49	1	Varicap*
(77)57-27	8	Silicon diode, 750 ma., 500 PIV
(78)57-44	2	Selenium diode, 2 ma., 1750 PIV
(79)404-304	1	Crystals (matched set, 350 kHz and 349,850 kHz)
411-10	1	6AT6 tube
411-11	1	6AU6 tube
411-25	1	12AU7 tube

*Registered trademark of TRW Semiconductors, Inc.

PART No. PARTS Per Kit DESCRIPTION

Diodes-Crystals-Tubes-Lamp (cont'd.)

411-124	1	6EA8 tube
411-170	2	6EW6 tube
411-232	1	3RP7 CR tube
(80)412-56	2	NE-83 neon lamp

MISCELLANEOUS

(81)73-44	2	3/4" plastic grommet
73-46	1	5/16" plastic grommet
(82)73-5	1	Rubber cushion strip
(83)75-24	1	Line cord strain relief
89-1	1	Line cord
(84)134-139	1	Wire harness
(85)205-254	1	Alignment tool blade
(86)206-30	1	Spiral shield
(87)206-304	1	CRT shield
(88)261-9	4	Rubber foot
(89)261-25	2	Plastic foot
(90)255-59	2	Plastic foot spacer
343-5	1	Coaxial cable
344-50	1	Hookup wire
346-1	1	Sleeving
391-47	1	Nameplate
(91)413-10	1	Pilot lamp lens
421-20	1	1/2 ampere slow-blow fuse
(92)422-1	1	Fuse block
(93)438-4	2	Phono plug
(94)462-191	9	Knob
(95)481-1	1	Capacitor mounting wafer
(96)414-17-1	1	Grid screen
490-1	1	Alignment tool
490-5	1	Nut starter
391-34	1	Identification label
597-260	1	Parts order form
597-308	1	Kit Builders Guide
		Manual (See front cover for part number.)
		Solder

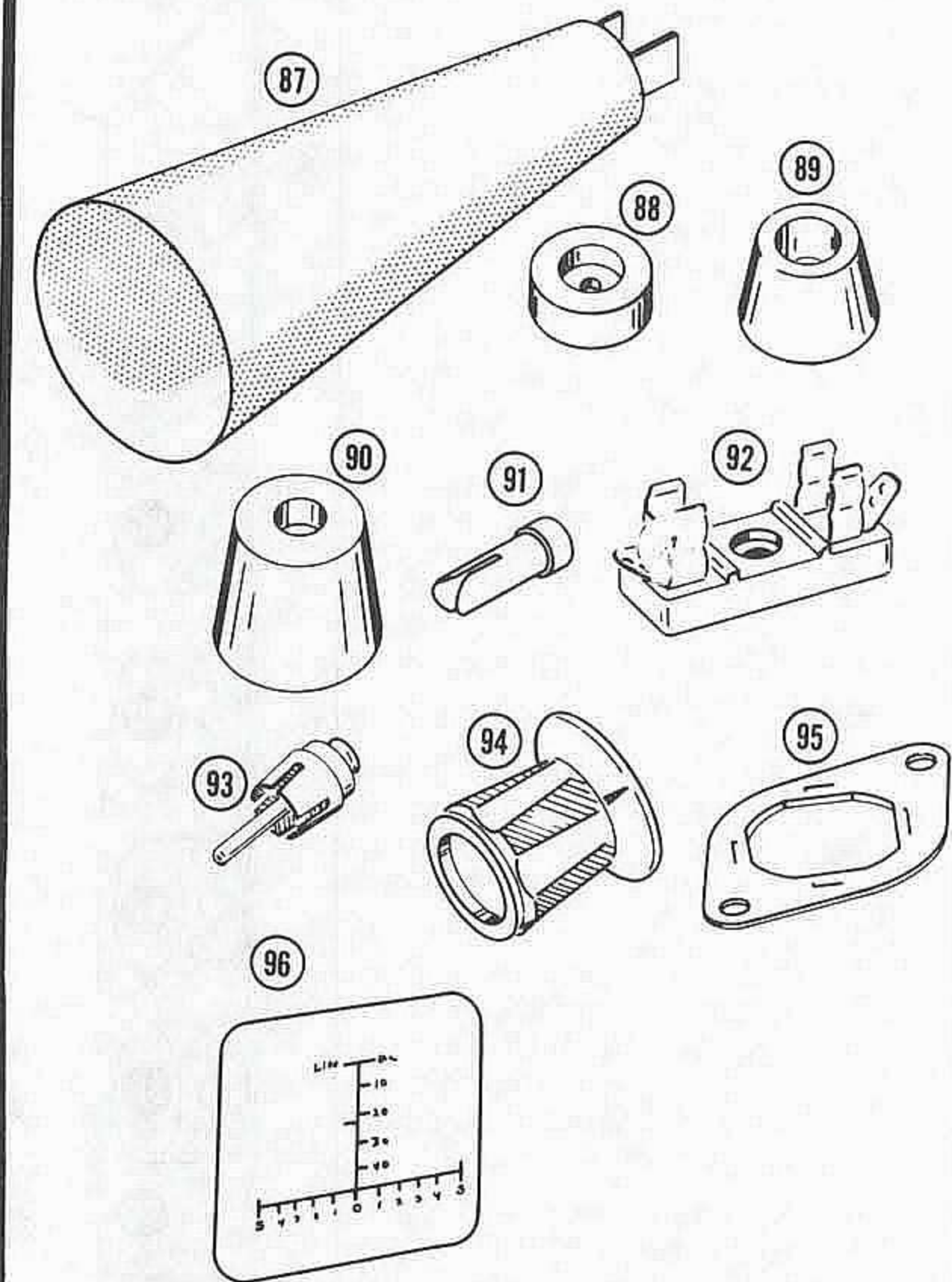
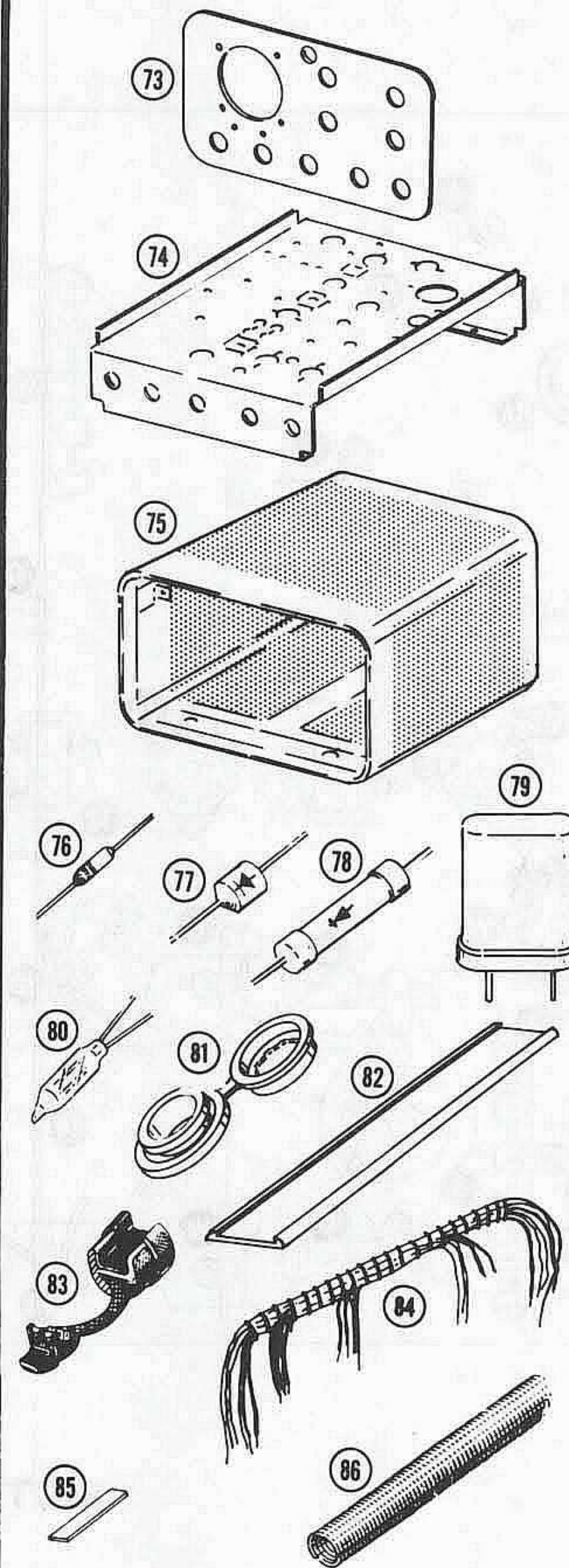
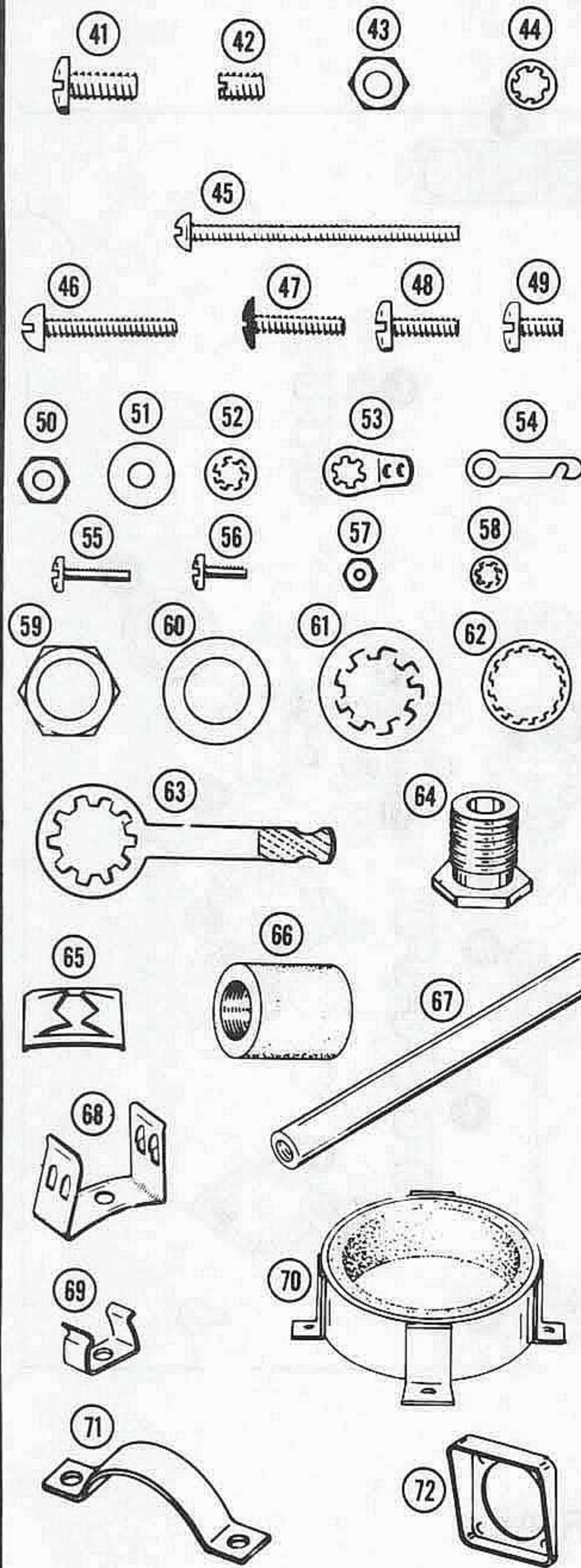
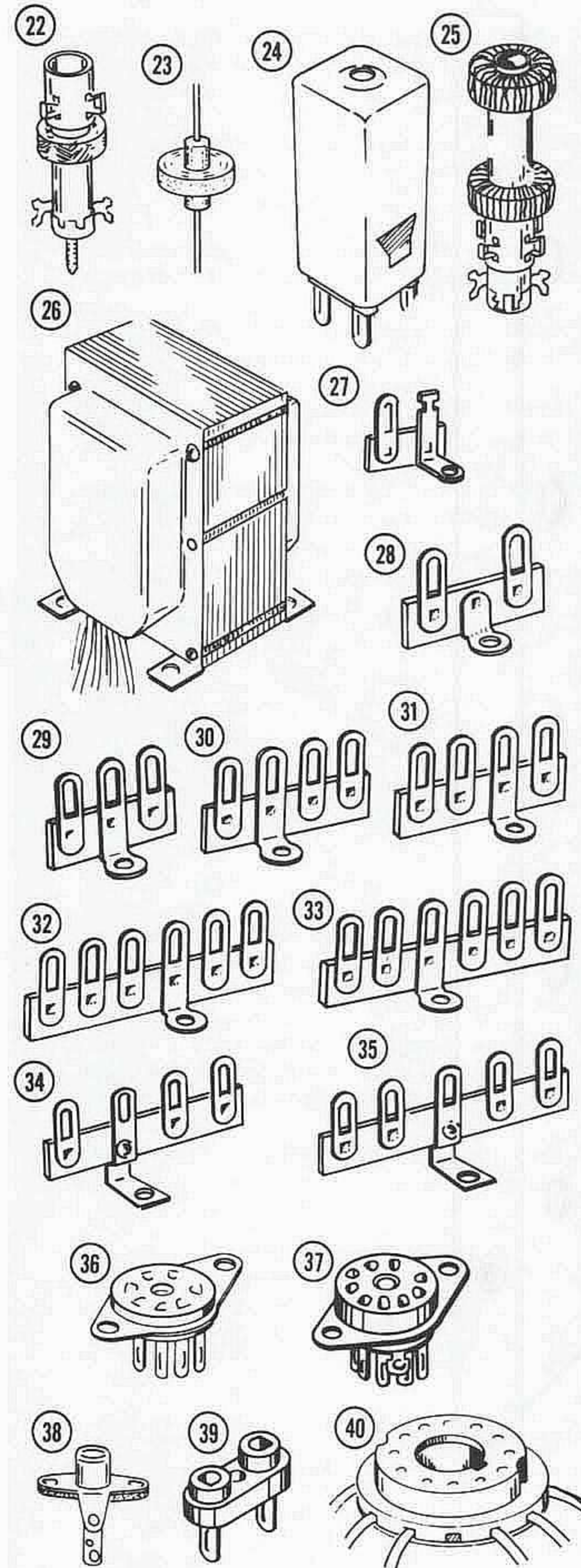

STEP-BY-STEP ASSEMBLY

Before you start to assemble the kit, read the Kit Builders Guide for complete information on wiring, soldering, and step-by-step assembly procedures. Do not unpack the CRT until it is called for in a step.

Refer to Pictorial 1 for the following steps.

- () Locate the chassis and position it as shown in Pictorial 1.

NOTE: When hardware is called for in a step, only the screw size will be given. For instance, if "3-48 x 1/4" hardware" is called for, it means that a 3-48 x 1/4" screw, one or more #3 lockwashers, and a 3-48 nut should be used. The Detail referred to in the step will show the proper number of lockwashers to use.

The Heath Company has provided a plastic nut starter with this kit. Use this nut starter to hold and start 6-32 and 3-48 nuts on screws. Refer to Page 3 of the Kit Builders Guide for further information.

- () Refer to Detail 1A and mount a 7-pin tube socket at V1 with a small #6 solder lug at Z. Use 3-48 x 1/4" hardware. Position the blank space of the tube socket as shown by the arrow. Bend solder lug Z up away from the chassis.

- () Similarly, mount a 7-pin tube socket at V3 with a small #6 solder lug at K. Use 3-48 x 1/4" hardware. Bend the solder lug up.

NOTE: Several terminal strips are used in this kit that have similar descriptions (for example: 2-lug terminal strip #431-57 and 2-lug terminal strip #431-32). Be sure to use the correct terminal strip as called out in the step. If necessary, use the terminal strip part numbers to refer back to the Parts List and Parts Pictorial.

- () Refer to Detail 1B and mount a 7-pin tube socket at V4 with a small 2-lug terminal strip (#431-57) at J. Use 3-48 x 1/4" hardware. Note that lockwashers are used both above and below the terminal strip mounting foot.

- () Mount a 7-pin tube socket at V5 with a small #6 solder lug at H. Use 3-48 x 1/4" hardware and bend the solder lug up away from the chassis.

- () Bend the ground lugs (four on each socket) on the two 9-pin tube sockets away from the sockets so the lugs are parallel with the mounting surface.

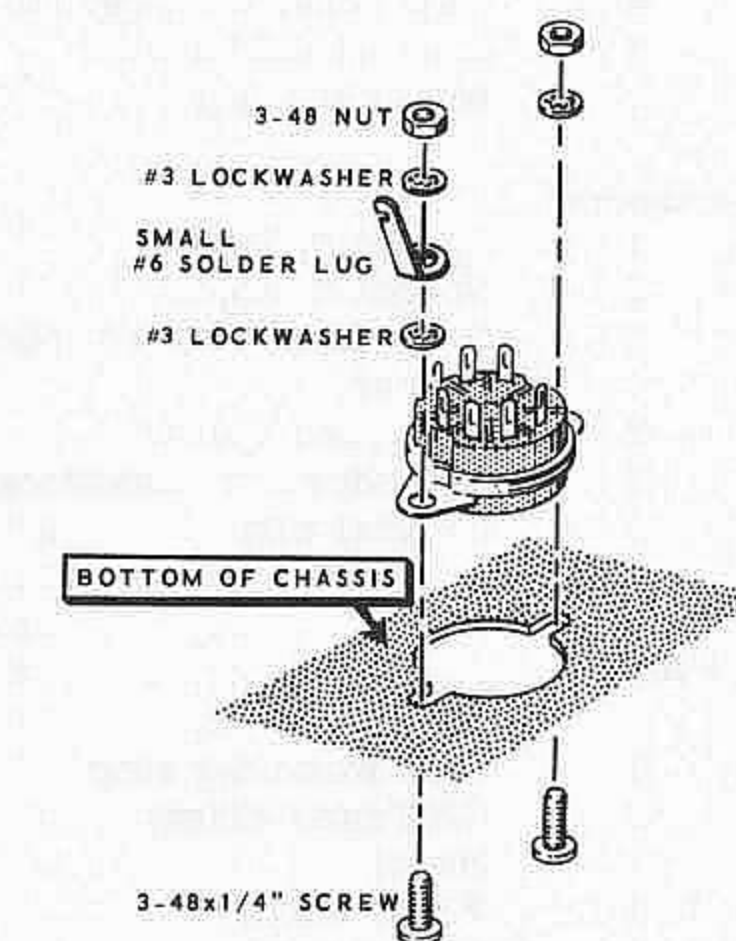

Detail 1A

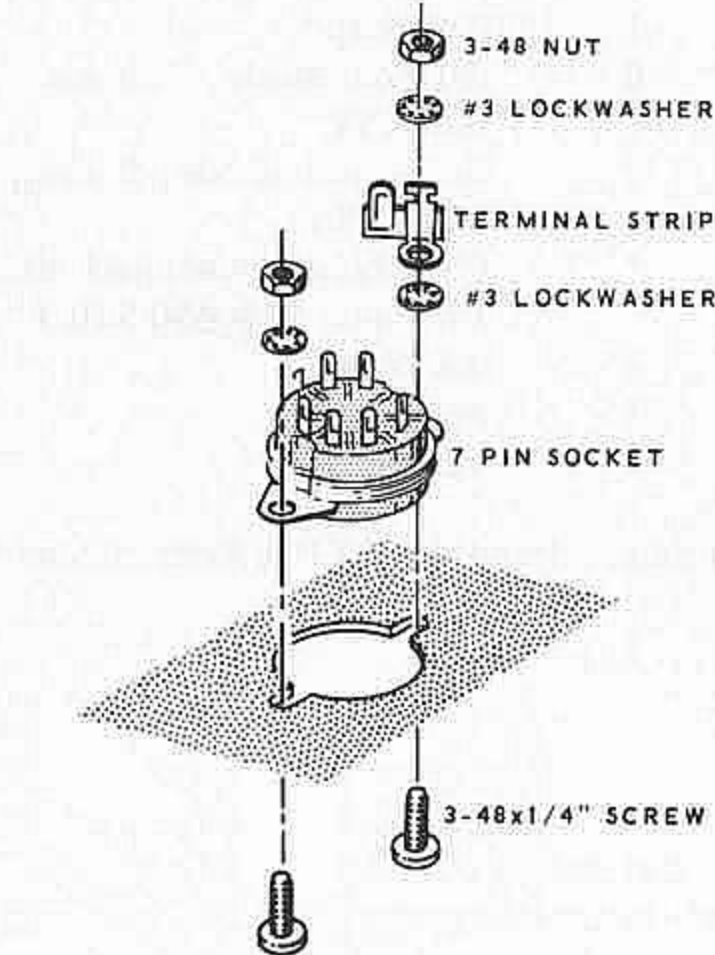

Detail 1B

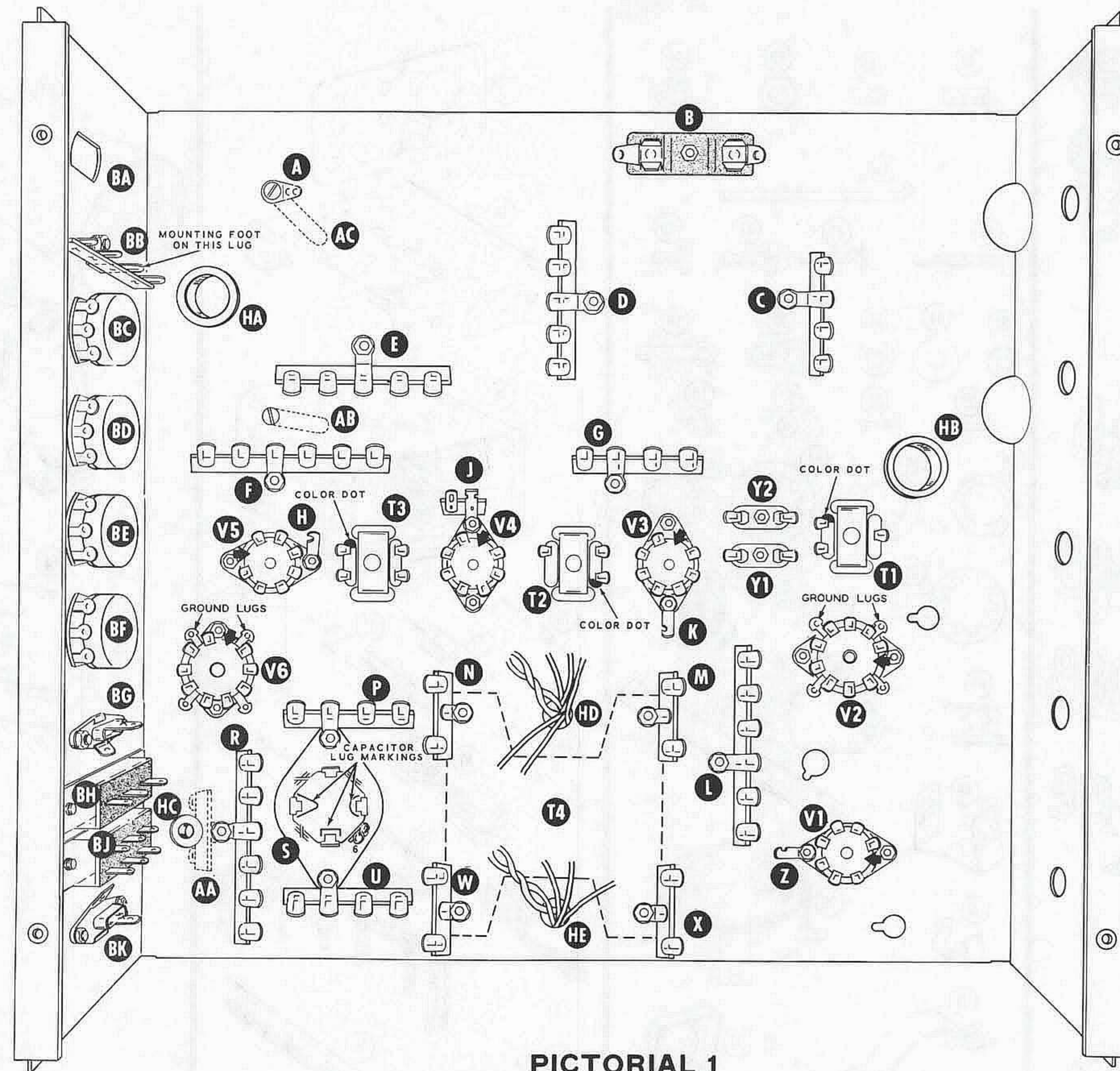

PICTORIAL 1

- () Mount a 9-pin tube socket at V2. Use 3-48 x 1/4" hardware. Position the blank space of the tube socket as shown by the arrows.
- () Mount a 9-pin tube socket at V6. Use 3-48 x 1/4" hardware and position the blank space as shown.

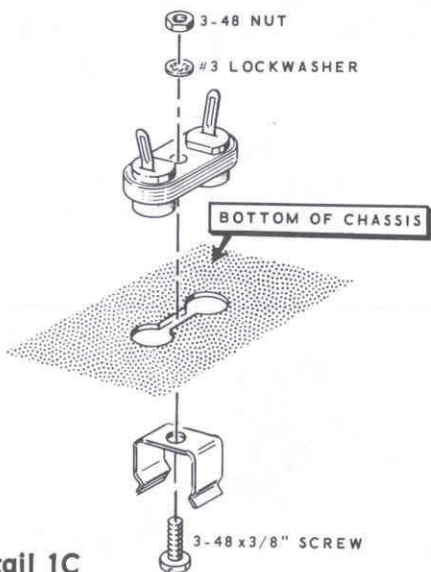

Detail 1C

- () Refer to Detail 1C and mount a crystal socket and clip at Y1. Use 3-48 x 3/8" hardware. Position the crystal clip on top of the chassis as shown. Be careful not to overtighten the hardware or the crystal socket will crack.
- () Similarly, mount a crystal socket with a crystal clip at Y2. Use 3-48 x 3/8" hardware.

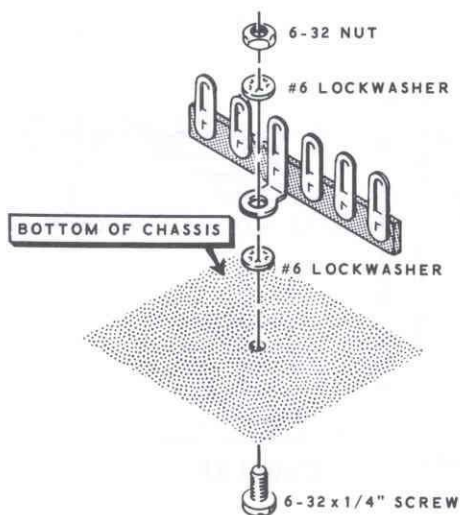

Detail 1D

- () Refer to Detail 1D and mount a 6-lug terminal strip (#431-55) at F. Use 6-32 x 1/4" hardware.
- () Mount 5-lug high voltage terminal strips (#431-42) at E and D. Use 6-32 x 1/4" hardware.
- () Mount a 4-lug high voltage terminal strip (#431-44) at C. Use 6-32 x 1/4" hardware.
- () Mount a 4-lug terminal strip (#431-12) at G. Use 6-32 x 1/4" hardware.
- () Mount a 6-lug terminal strip (#431-45) at L. Use 6-32 x 1/4" hardware.
- () Refer to Detail 1E and mount the fuse block at B. Use 6-32 x 3/8" hardware.

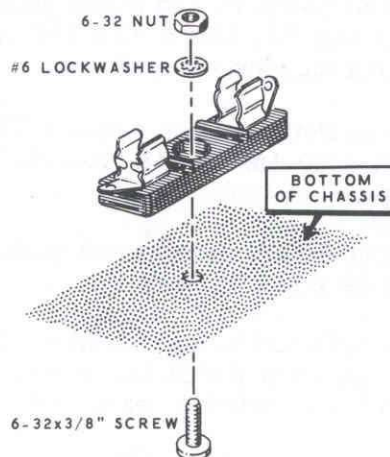

Detail 1E

- () Refer to Detail 1F and install 3/4" plastic grommets at HA and HB. Install the grommets from the top of the chassis.
- () Similarly, install a 5/16" plastic grommet at HC.

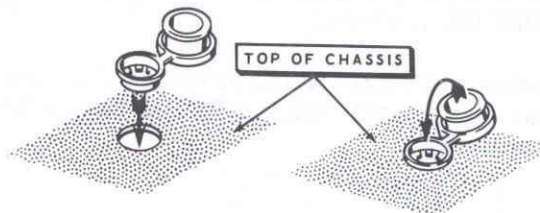

POSITION THE SMALL PORTION OF THE GROMMET INTO THE CHASSIS HOLE.

BEND THE LARGE PORTION OF THE GROMMET OVER AND INTO THE SMALL PORTION. PRESS IT FIRMLY INTO PLACE.

Detail 1F

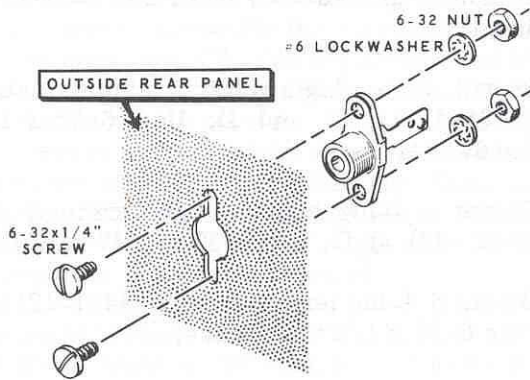

Detail 1G

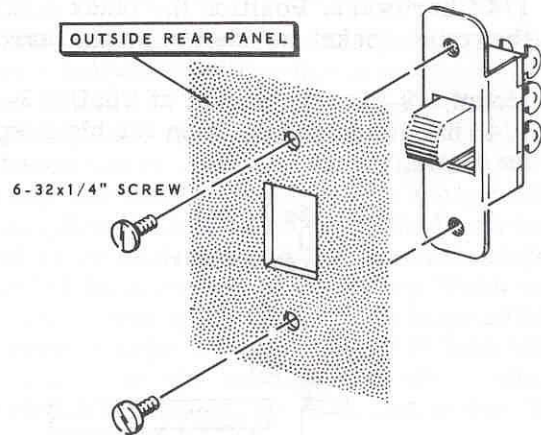

Detail 1H

- () Refer to Detail 1G and mount phono sockets at BG and BK. Use 6-32 x 1/4" hardware. Position the phono sockets as shown.
- () Refer to Detail 1H and mount a DPDT slide switch (#60-15) at BJ. Use 6-32 x 1/4" screws.
- () Mount a SPDT slide switch (#60-4) at BH. Use 6-32 x 1/4" screws.
- () Refer to Detail 1J and mount a 7.5 megohm twist-tab control (#10-115) at BF. Secure the control by twisting each tab 1/8 turn.
- () Mount a 1 megohm twist-tab control (#10-127) at BE. Secure the control by twisting each tab 1/8 turn.
- () Mount a 100 K Ω twist-tab control (#10-58) at BD. Secure the control by twisting each tab 1/8 turn.
- () Mount a 1 megohm twist-tab control (#10-127) at BC. Secure the control by twisting each tab 1/8 turn.
- () Refer to Detail 1K and mount a 4-lug terminal strip (#431-12) at BB. Use 6-32 x 1/4" hardware.

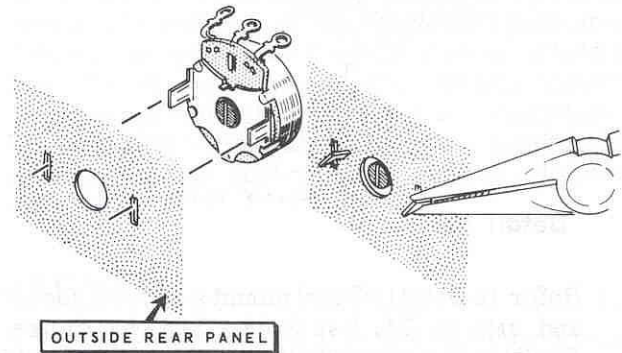

Detail 1J

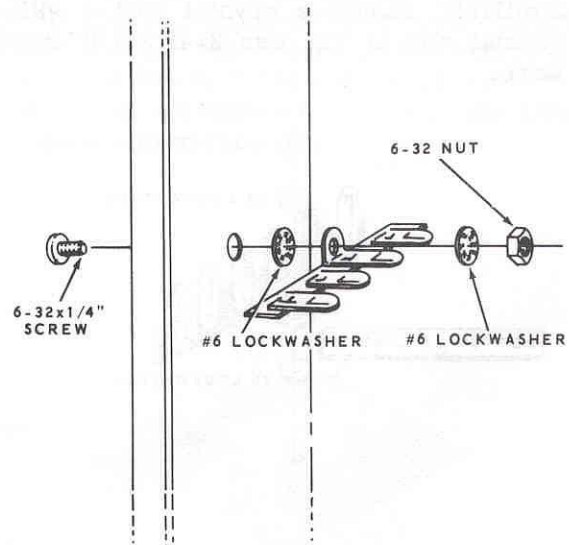

Detail 1K

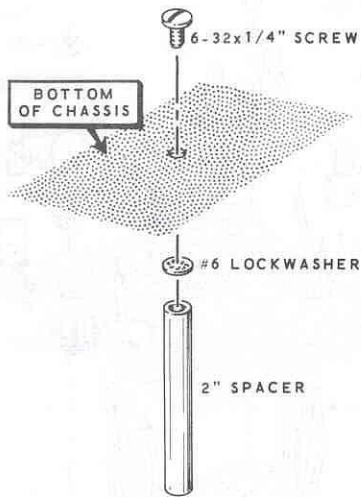

Detail 1L

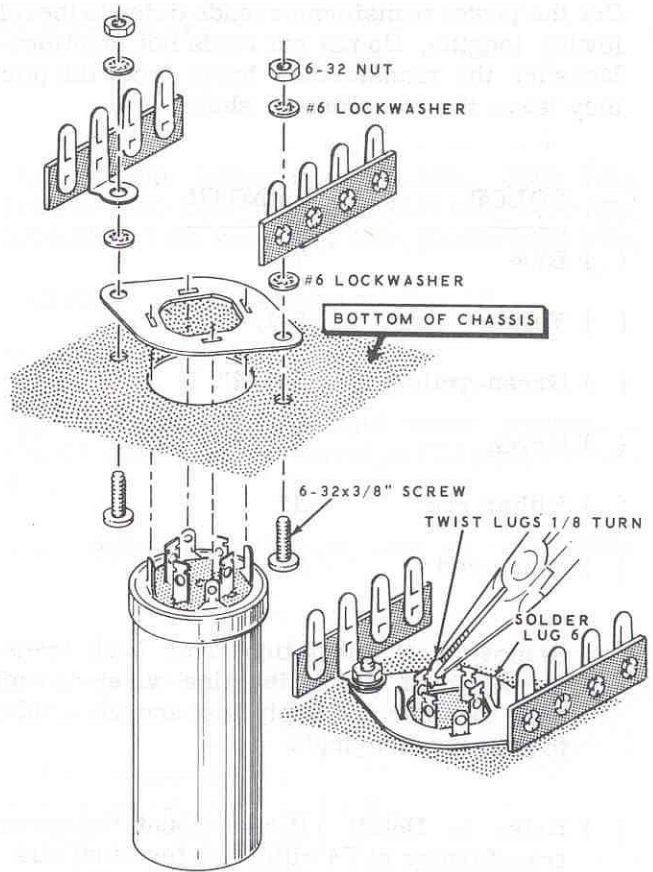

Detail 1M

- () Refer to Detail 1L and mount a 2" tapped spacer on top of the chassis at AB. Use a #6 lockwasher and a 6-32 x 1/4" screw.
- () Mount a 2" tapped spacer on top of the chassis at AC and a large #6 solder lug on the bottom of the chassis at A. Use a 6-32 x 3/8" screw.
- () Refer to Detail 1M and mount a capacitor mounting wafer at S with a 4-lug terminal strip (#431-12) at P and a 4-lug terminal strip (#431-40) at U. Use 6-32 x 3/8" hardware.
- () Refer to Detail 1N and mount a 3-lug terminal strip (#431-10) on top of the chassis at AA and a 6-lug terminal strip (#431-55) on the bottom of the chassis at R. Use 6-32 x 3/8" hardware. Position the terminal strips as shown in Pictorial 1.
- () Install the 60-40-20-20 μ fd electrolytic capacitor in the mounting wafer at S. Position the capacitor lug markings as shown in Pictorial 1. Secure the capacitor by twisting each mounting lug 1/8 turn.
- () Solder lug 6 of capacitor S to the metal mounting wafer.

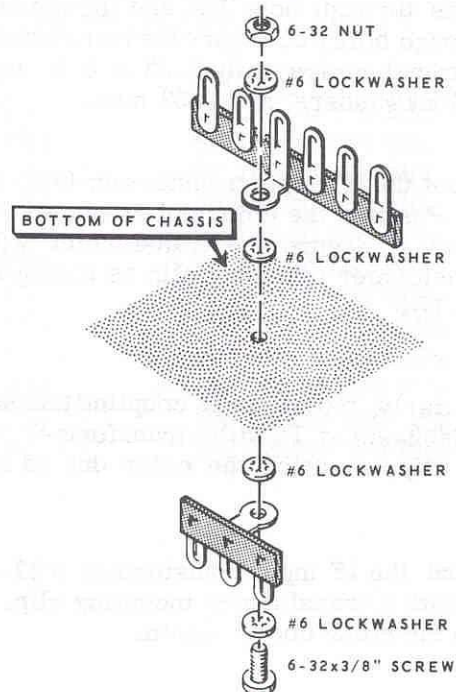

Detail 1N

Cut the power transformer leads listed to the following lengths. Do not cut leads not mentioned. Measure the transformer leads from the point they leave the transformer shell.

COLOR	LENGTH
() Blue	7"
() Yellow	5-1/4"
() Green-yellow	5-1/4"
() Green	4-1/2"
() Either red	4"
() Other red	2-1/4"

() Remove 1/4" insulation from each transformer lead. Twist the fine wires of each lead together and apply just enough solder to prevent "fraying".

() Refer to Detail 1P and mount the power transformer at T4 with 2-lug terminal strips (#431-32) at M, N, W, and X. Place the green, both red, blue, and green/yellow leads through hole HE and the other leads through hole HD. Secure the transformer and terminal strips with 8-32 x 3/8" screws, #8 lockwashers, and 8-32 nuts.

() Mount the IF output transformer (#52-100) at T3. Position the color dot as shown in Pictorial 1. Secure the transformer with the transformer mounting clip as shown in Detail 1R.

() Similarly, mount the IF coupling transformer (#52-96) at T2 with a transformer mounting clip. Position the color dot as shown.

() Mount the IF input transformer (#52-95) at T1 with a transformer mounting clip. Position the color dot as shown.

() Place the chassis aside temporarily.

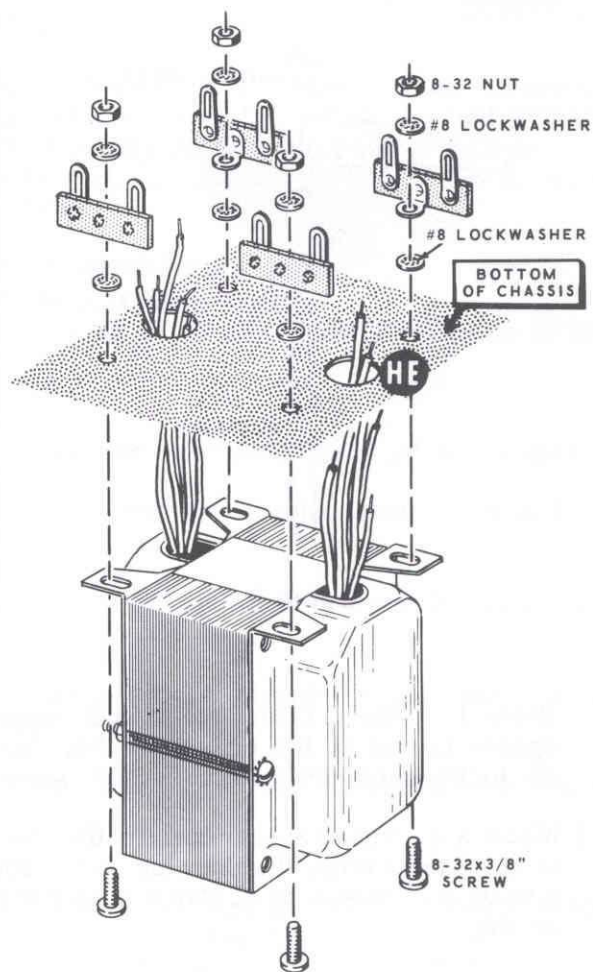

Detail 1P

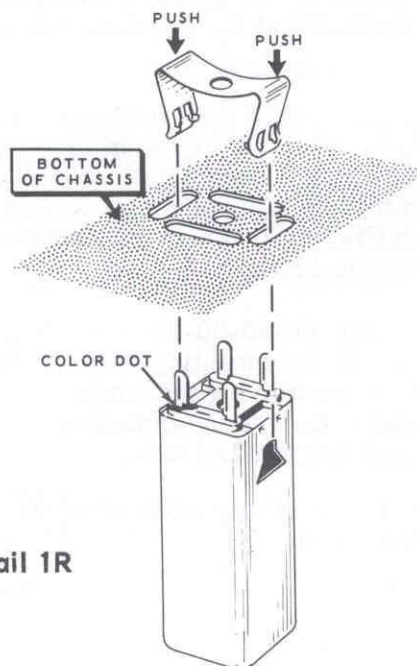

Detail 1R

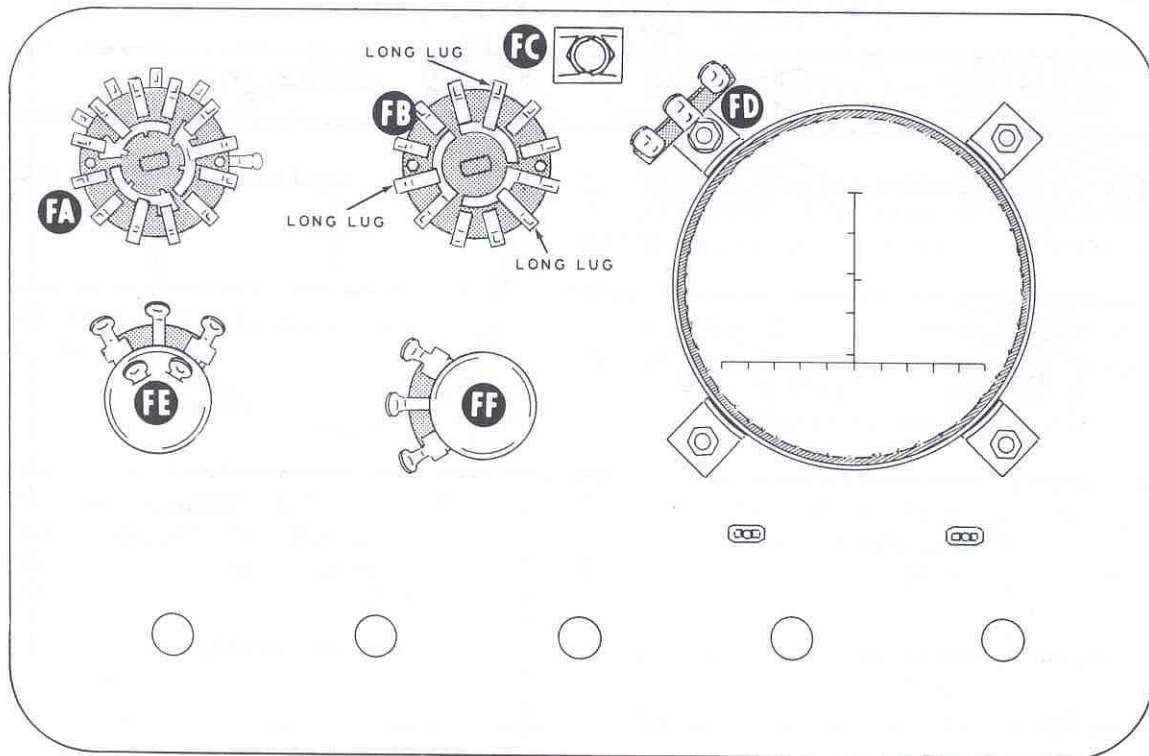

PICTORIAL 2

PANEL PARTS MOUNTING

Refer to Pictorial 2 for the following steps.

- () Place a soft cloth over your work area to protect the finish on the front panel. To further protect the finish during assembly, masking tape may be placed around each edge of the front panel.

- () Refer to Detail 2A and install the nameplate on the front panel. Use two speednuts as shown.

- () Refer to Detail 2B and install the neon lamp lens at FC using a push-on speednut.

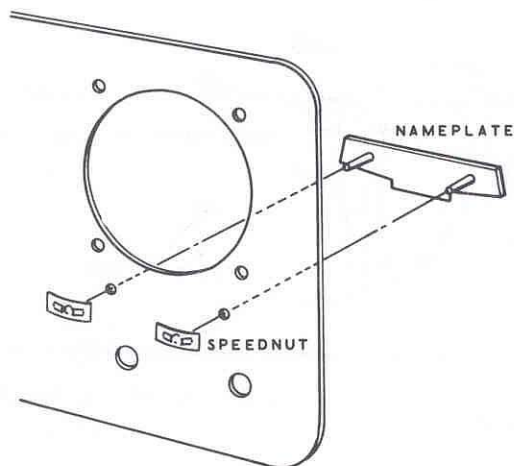

Detail 2A

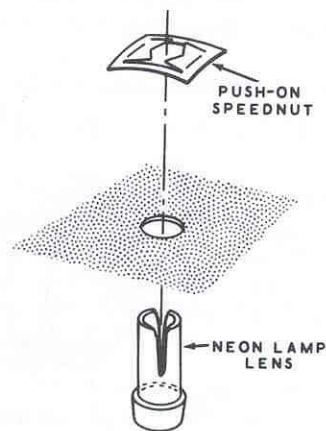

Detail 2B

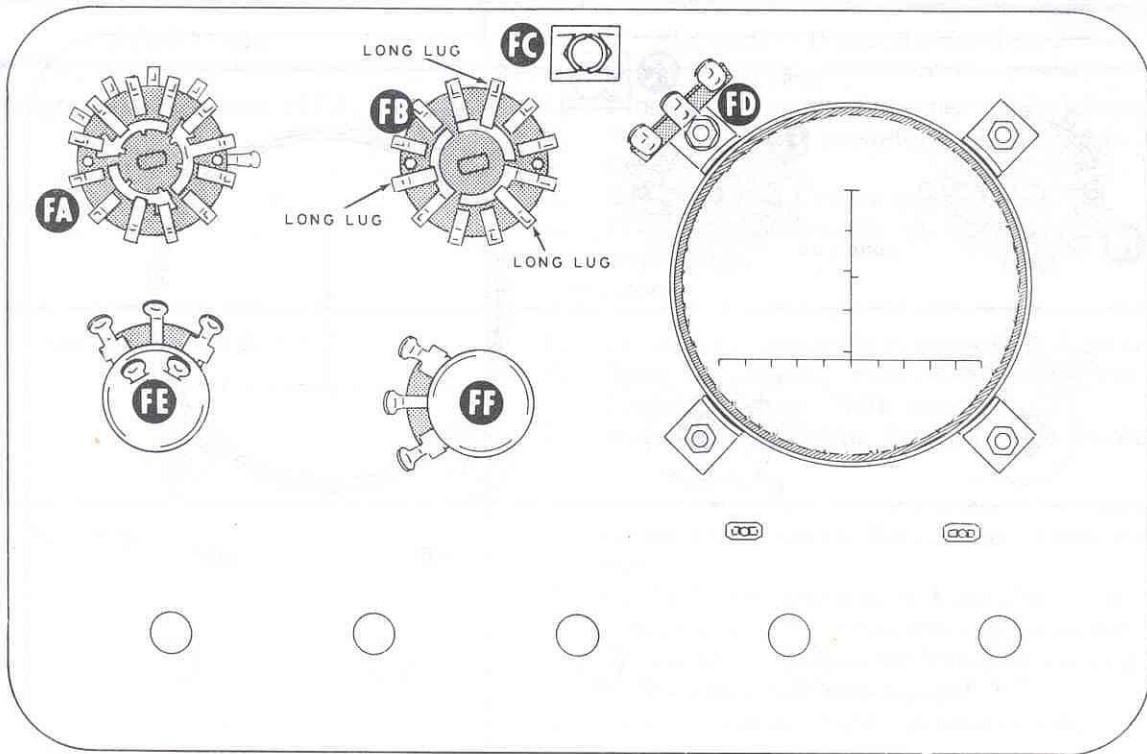

PICTORIAL 2
(Repeat)

NOTE: If the grid screen in the following step has a protective covering on one or both sides, be sure it is removed before the grid screen is mounted so the pattern may be focused.

() Refer to Detail 2C and mount the CRT mounting ring, grid screen, and bezel on the front panel with a 3-lug terminal strip at FD. Use 6-32 x 1/2" black screws and 6-32 hardware. Be sure the markings on the grid screen and the bezel are square with the panel.

() Refer to Detail 2D and start a control nut on the bushing of a 7.5 megohm control (#10-94). Turn the nut tightly against the bottom of the bushing. Now mount this control at FF with a thin control lockwasher, a control flat washer and a control nut.

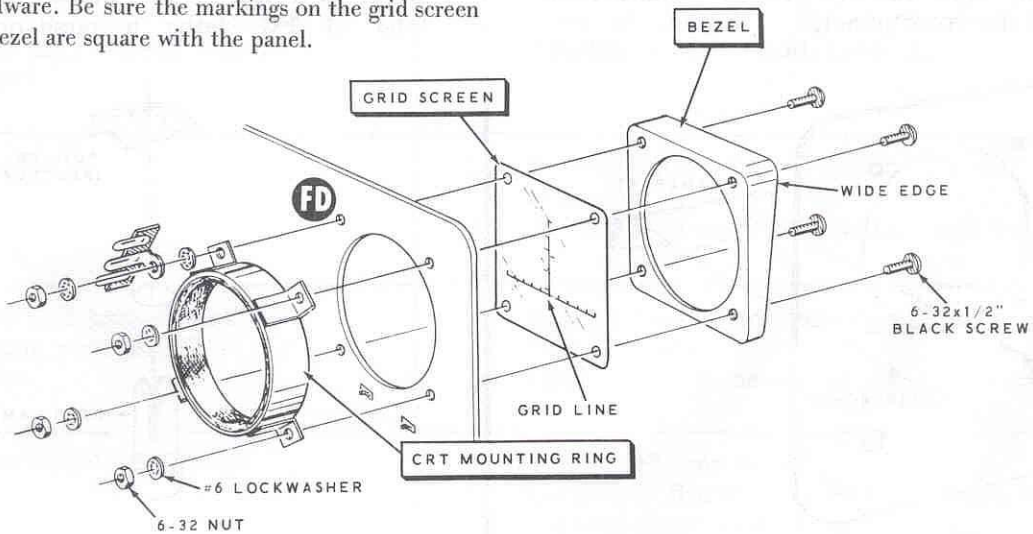

Detail 2C

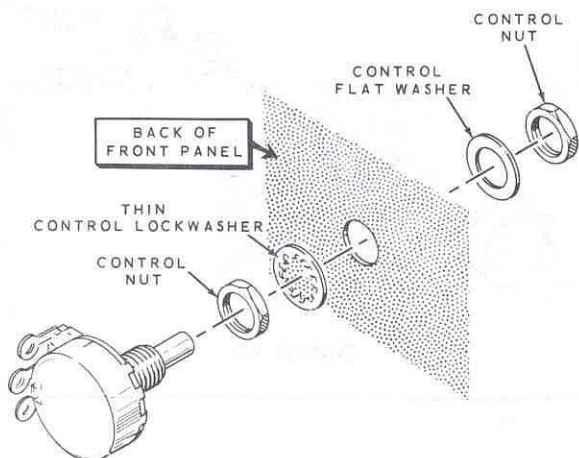

Detail 2D

- () Mount a 500 K Ω control with switch (#19-80) at FE. Use a thin control lockwasher, a control flat washer, and a control nut.
- () Refer to Detail 2E and mount a 3-position, 4-pole, single-wafer switch (#63-439) at FA. Note the position of the 4 lugs on the front of the switch wafer. Use a control solder lug, a control flat washer, and a control nut.
- () Refer to Detail 2F and mount a 3-position, 3 pole, single-wafer switch (#63-336) at FB. Use a thin control lockwasher, a control flat washer, and a control nut. Note carefully the position of the long lugs.

Refer to Pictorial 3 (fold-out from Page 17) for the following steps.

NOTE: When mounting the following five controls, position the controls as shown. Do not tighten the control nuts until instructed to do so.

- () Position the panel and chassis as shown in Detail 3A, and mount a 1 megohm control at FH. Use a thin control lockwasher, a control flat washer, and a control nut.

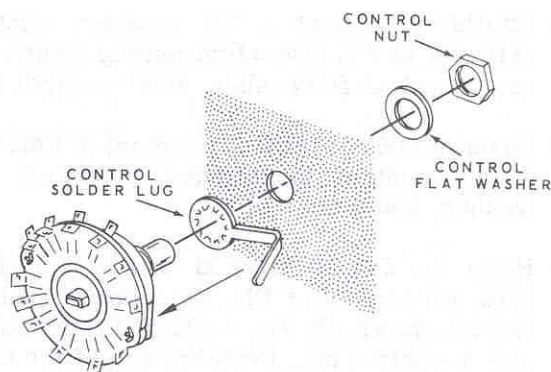

Detail 2E

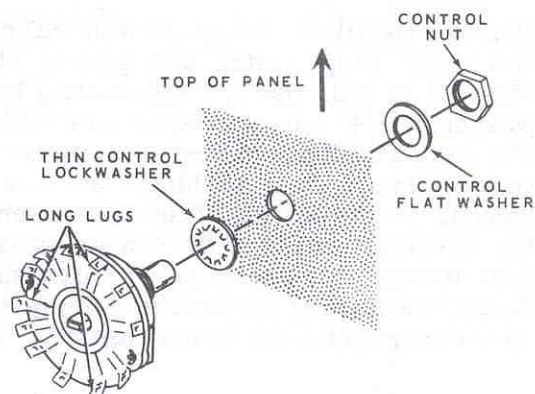

Detail 2F

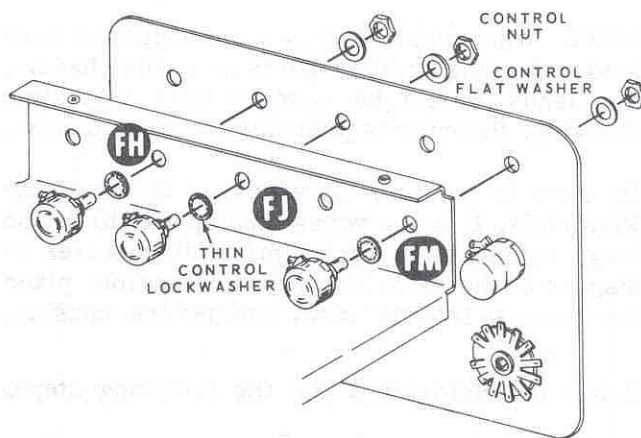

Detail 3A

- () Similarly, mount a 7.5 megohm control (#10-94) at FJ. Use a thin control lockwasher, a control flatwasher, and a control nut.
- () Mount a 5000 Ω (#10-42) control at FM. Use a thin control lockwasher, a control flat washer, and a control nut.
- () Refer to Detail 3B and mount a 5000 Ω (#10-42) control at FK. Use a control solder lug as shown at FL, a control flat washer and a control nut. Bend the end of the control solder lug so it does not interfere with lug 2 of control FM.

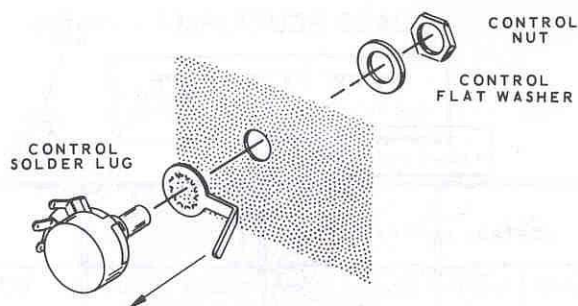

Detail 3B

- () Refer to Detail 3C and mount a 500 K Ω control with snap switch and plastic shaft (#19-78) at FG. Use a thick control lockwasher, a 3/4" long phenolic spacer (#255-55), a thick control lockwasher, a control flat washer, and a brass bushing. Note that the threads on the outside of the bushing enter the interior threads of the spacer, passing first through the thick control lockwasher. To avoid stripping the threads of the spacer, do not overtighten the brass bushing.
- () Align the bottom edge of the chassis with the front panel, and tighten the five control nuts.

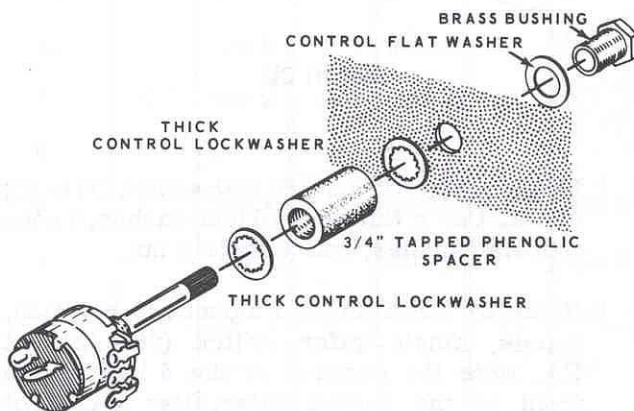

Detail 3C

INITIAL WIRING

NOTE: Wherever there is a possibility of bare leads shorting to other parts or to the chassis, the leads should be covered with insulating sleeving. Sleeving is provided for this purpose.

Be sure to position all wires as shown in the Pictorials. If some wires then appear to be too long, double them back against themselves to dispose of the extra length and, if feasible, place the excess lengths down against the chassis.

Refer to Pictorial 3 for the following steps.

Connect the power transformer leads extending from hole HE as follows:

- () Short red lead to lug 1 of terminal strip X (NS).

- () Long red lead to lug 3 of terminal strip U (NS).
- () Green lead to lug 5 of terminal strip R (NS).
- () Green-yellow lead to lug 2 of terminal strip R (NS).

The blue lead will be connected later.

- () Connect a 4-3/4" hookup wire from lug 4 of terminal strip R (NS) to lug 4 of tube socket V5 (NS).

Connect the power transformer leads extending from hole HD (except the yellow lead) as follows; route the leads as shown:

- () Connect either brown lead to lug 2 of terminal strip E (NS).

- () Connect the other brown lead to lug 1 of terminal strip E (NS).
- () Connect the black lead to lug 4 of terminal strip BB (NS).
- () Connect the black-red lead to lug 2 of terminal strip BB (NS).

NOTE: The power transformer has a dual primary winding and can be wired to operate from either 120 volts or 240 volts. Determine the AC line voltage in your area and follow the proper set of steps to wire the power transformer.

120 Volt Wiring

- () Connect the black-green lead to lug 4 of terminal strip BB (NS).
- () Connect the black-yellow lead to lug 2 of terminal strip BB (NS).

240 Volt Wiring

Refer to the inset drawing on Pictorial 3 for the following steps.

- () Connect the black-green lead to lug 1 of terminal strip BB (NS).
- () Connect the black-yellow lead to lug 1 of terminal strip BB (S-2).

- () Cut the length of spiral shield in half. Slide one half of the spiral shield over the yellow lead extending from hole HD. Slide the remaining half of the spiral shield over the blue lead extending from hole HE.
- () Connect the yellow lead from hole HD to lug 4 of terminal strip D (NS).

- () Connect the blue lead from hole HE to lug 5 of terminal strip D (NS).
- () Position the spiral shield on the yellow and blue leads as shown in Pictorial 3.
- () Remove all the insulation from a 1-1/4" length of hookup wire. Then bend a hook in one end of this bare wire and hook it over the spiral shield as shown. Solder the bare wire to the spiral shield.
- () Connect the free end of the bare wire to lug 2 of terminal strip J (NS).
- () Connect one end of a 4" hookup wire to lug 6 of terminal strip R (NS). Place the other end of this wire through grommet HC. It will be connected later.
- () Refer to Detail 3D and twist two 15" hookup wires together until there are approximately three turns every two inches.

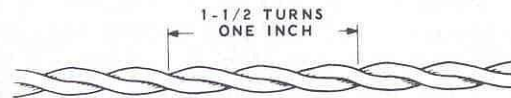

Detail 3D

NOTE: In the next few steps, to prepare the twisted pairs of wires that are called for, cut the indicated length from the wires twisted in the previous step. Then unwind the ends for a short distance and remove 1/4" of insulation from both wires at both ends.

- () At one end of a 4-1/2" twisted pair, connect either wire to lug 5 (NS) and the other wire to lug 2 (NS) of terminal strip R.
- () At the other end of this twisted pair, connect either wire to lug 9 (NS) and the other wire to lug 5 (NS) of tube socket V6.

NOTE: Where a wire passes through a connection and then goes to another point, as in the next step, it will count as two wires in the solder instructions (S-2), one entering and one leaving the connection.

- () At one end of a 4" twisted pair, connect either wire to lug 9 of tube socket V6 (S-2). Remove a total of 1/2" of insulation from the other wire in this twisted pair. Place this wire through lug 4 (S-2) to lug 5 (S-2) of tube socket V6.
- () At the other end of this twisted pair, connect either wire to lug 3 (NS) and the other wire to lug 4 (NS) of tube socket V4.
- () At one end of a 4" twisted pair, connect either wire to lug 3 (S-2) and the other wire to lug 4 (S-2) of tube socket V4.
- () At the other end of this twisted pair connect either wire to lug 3 (S-1) and the other wire to lug 4 (S-1) of tube socket V3.

NOTE: When wiring this kit, you will be instructed to prepare the lengths of hookup wire ahead of time, as in the next step. To prepare a wire, cut it to the indicated length and strip 1/4" of insulation from each end. The wires are listed in the order in which they will be used.

- () Prepare the following lengths of hookup wire:

7"	5"
3-1/4"	7"
3-3/4"	2"
4-3/4"	5"

- () Connect a 7" wire from lug 4 of tube socket V5 (S-2) to lug 4 of tube socket V2 (NS).

- () Connect a 3-1/4" wire from lug 4 of tube socket V2 (S-2) to lug 4 of tube socket V1 (NS).
- () Connect a 3-3/4" wire from lug 4 of tube socket V1 (NS) to lug 2 of terminal strip X (NS).
- () Connect a 4-3/4" wire from lug 1 of terminal strip X (NS) to lug 2 of electrolytic capacitor S (S-1).
- () Connect a 5" hookup wire from lug 2 of terminal strip M (NS) to lug 3 of electrolytic capacitor S (NS).
- () Remove an additional 3/4" of insulation from a 7" hookup wire. Then connect this wire from lug 1 of terminal strip M (NS), through lug 4 (NS), to lug 1 (NS) of electrolytic capacitor S (NS).
- () Connect a 2" hookup wire from lug 2 of terminal strip U (NS) to lug 2 of terminal strip W (NS).
- () Connect a 5" hookup wire from lug 3 of terminal strip P (NS) to lug 1 of control BF (NS).

- () Prepare the following lengths of hookup wire:

3-1/4"	2"
5"	9-1/4"
3"	1-1/2"
3"	1-1/4"

- () Connect a 3-1/4" wire from lug 1 of terminal strip P (NS) to lug 2 of terminal strip N (NS).

- () Connect a 5" wire from lug 1 of terminal strip P (NS) to lug 3 of control BE (NS).
- () Connect a 3" wire from lug 3 of control BE (S-2) to lug 3 of control BC (S-1).
- () Connect a 3" wire from lug 1 of control BE (S-1) to lug 1 of control BC (NS).
- () Connect a 2" hookup wire from lug 1 of control BC (S-2) to lug 3 of terminal strip BB (S-1).
- () Refer to Detail 3E and cut the CRT socket leads to the dimensions shown. CAUTION: DO NOT STRIP THE BRN LEAD FROM LUG 12 OF THE CRT SOCKET. Remove 1/4" of insulation from each of the other wires.

MEASURE ALL LEADS FROM EDGE OF SOCKET

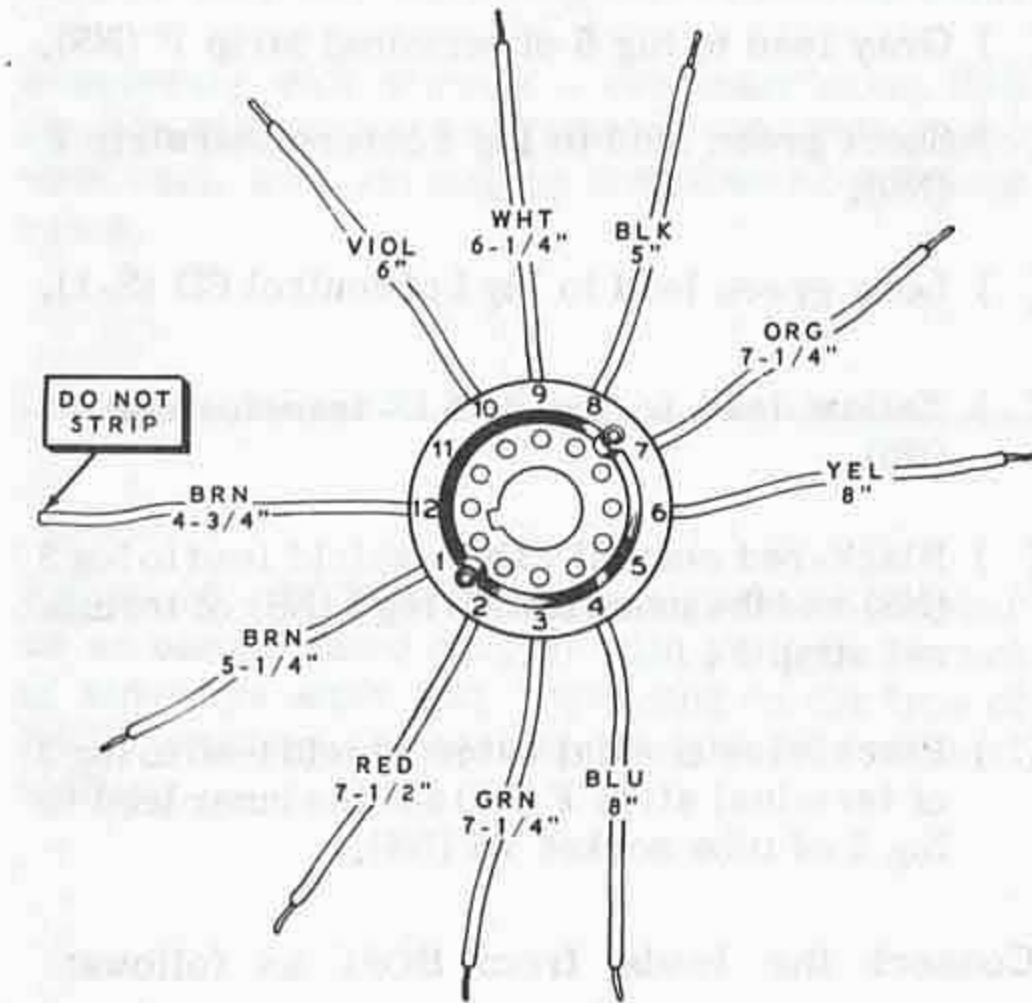

Detail 3E

- () Place all of the CRT socket leads through grommet HA from the top of the chassis. Position the socket keyway as shown.

Connect each CRT socket lead as directed in the following steps:

LEAD COLOR	CONNECT TO
() Red	lug 2 of terminal strip D (NS).
() Blue	lug 5 of terminal strip E (NS).
() Green	lug 4 of terminal strip E (NS).
() Violet	lug 7 of tube socket V5 (NS).
() Orange	lug 1 of tube socket V6 (NS).
() Yellow	lug 6 of tube socket V6 (NS).
() White	lug 2 of control BE (S-1).
() Black	lug 2 of control BC (S-1).

- () Connect the brown lead with the bared end to lug 2 of terminal strip E (NS).
- () Remove 1/4" of insulation from the remaining brown lead and connect it to lug 1 of terminal strip E (S-2).
- () Connect a 9-1/4" hookup wire from lug 4 of terminal strip BB (S-3 for 120 volt wiring, S-2 for 240 volt wiring) to lug 4 of control FG (S-1).
- () Connect a 1-1/2" hookup wire from lug 5 of control FG (S-1) to lug 2 of fuse block B (S-1).
- () Connect a 1-1/4" hookup wire from lug 3 of control FG (S-1) to lug 1 of terminal strip C (NS).

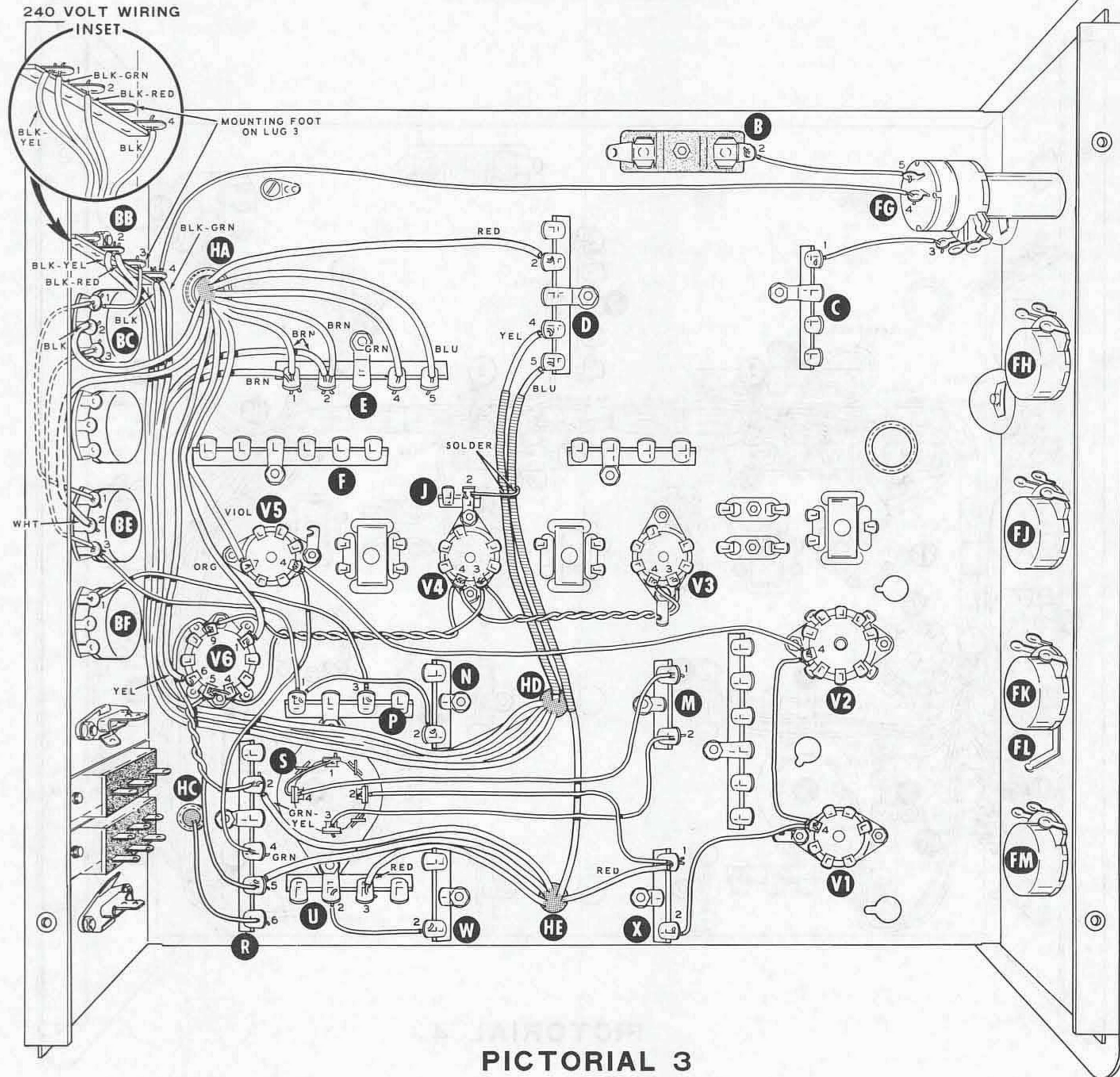

PICTORIAL 3

- () Brown lead through grommet HC to be connected later.
- () White lead to lug 1 of terminal strip N (NS).
- () Yellow lead to lug 4 of terminal strip P (NS).
- () Gray lead to lug 1 of terminal strip R (NS).
- () Black coaxial cable: shield lead to lug 1 of phono socket BG (NS) and the inner lead to lug 2 of switch BH (S-1).
- () Black-yellow coaxial cable: shield lead to lug 1 (NS) and the inner lead to lug 2 (S-1) of phono socket BG.
- () Remove a total of 3/4" of insulation from one end of a 2-1/2" wire. Place the 3/4" end of this wire through lug 12 (NS) to lug 1 (S-1) of switch FB. Connect the other end of this wire to lug 9 of FB (NS).
- () Connect a 3/4" bare wire between lugs 7 (NS) and 8 (S-1) of switch FB.
- () Connect a 33 K Ω 2 watt (orange-orange-orange) resistor between lugs 1 (NS) and 3 (NS) of terminal strip FD.
- () Slide a neon lamp into the neon lamp socket at FC. Connect one lamp lead to lug 1 of terminal strip FD (NS) and the other lamp lead to lug 12 of switch FB (S-3).

PANEL AND SWITCH WIRING

Refer to Pictorial 5 (fold-out from Page 21) for the following steps.

- () Position the cable assembly leads along the chassis as shown.

NOTE: Several leads will be connected to the solder lug mounted with switch FA. The lead connections should be made in two groups, one near the bottom of the lug and one near the top of the lug. These two groups will be soldered separately. The leads in the next three steps connect to the bottom of the solder lug.

When resistors are installed, use only the 1/2 watt resistors unless higher wattage resistors are specifically called for.

- () Connect a 470 K Ω (yellow-violet-yellow) resistor from lug 1 of control FE (S-1) to the solder lug on switch FA (NS).
- () Connect a 62 Ω (blue-red-black) resistor from lug 1 of switch FA (NS) to the solder lug on FA (NS).
- () Connect a .1 μ fd resin capacitor from lug 15 of switch FA (NS) to the solder lug on FA (S-3).
- () Connect a 2-1/2" wire from the solder lug on switch FA (NS) to lug 9 of switch FB (NS).
- () Connect the cable assembly leads from BO#5 as follows:
 - () Blue lead to lug 3 of control FF (NS).
 - () Red lead to lug 1 of terminal strip FD (S-3).
 - () Orange lead to lug 3 of terminal strip FD (S-2).
 - () Violet lead to lug 2 of switch FB (S-1).
 - () Remove an additional 1/4" of insulation from the green lead. Place this lead through lug 4 (S-2) to lug 3 (S-1) of switch FB.
 - () Gray lead to lug 5 of switch FB (S-1).
 - () White lead to lug 6 of switch FB (S-1).
 - () Brown lead to lug 11 of switch FB (S-1).
 - () Black lead to the solder lug on switch FA (NS).
 - () Black-green coaxial cable: shield lead to lug 9 (S-3) and the inner lead to lug 10 (S-1) of switch FB.
 - () Black-red coaxial cable: shield lead to the solder lug on switch FA (NS) and the inner lead to lug 7 of switch FB (S-2).
 - () Black-blue coaxial cable: shield lead to the solder lug on switch FA (NS) and the inner lead to lug 16 of switch FA (S-1).

CAUTION: Carefully observe the lugs of switch FA, as shown in Pictorial 5. The lugs around one side of the switch are very close together. Be sure you use the proper lug in each step, and be careful that you do not short circuit two lugs with wires or solder.

Connect the cable assembly leads from BO#6 as follows:

- () Violet lead to lug 2 of control FE (S-1).
- () White lead to lug 3 of control FE (S-1).
- () Gray lead to lug 4 of switch FA (S-1).
- () Yellow lead to lug 5 of switch FA (NS).
- () Brown lead to lug 8 of switch FA (NS).
- () Blue lead to lug 14 of switch FA (S-1).
- () Connect a 3" hookup wire from lug 5 of switch FA (NS) to lug 5 of control FE (S-1).
- () Remove a total of 1/2" of insulation from one end of an 8" hookup wire. Place this end of the wire through lug 1 (S-2) to lug 2 (S-1) of control FF. Connect the other end of this wire to lug 9 of switch FA (S-1).
- () Connect a 10 megohm (brown-black-blue) resistor from lug 4 of control FE (S-1) to lug 3 of control FF (S-2).
- () Connect a .005 μ fd disc capacitor between lugs 11 (S-1) and 13 (NS) of switch FA.
- () Connect a .02 μ fd disc capacitor between lugs 13 (S-2) and 15 (S-2) of switch FA.

Refer to Detail 5A (fold-out from Page 21) for the following steps.

- () Connect a 470 Ω (yellow-violet-brown) resistor between lugs 1 (S-2) and 2 (NS) of switch FA.

- () Connect an 1800 Ω (brown-gray-red) resistor between lugs 2 (S-2) and 3 (S-1) of switch FA.
- () Connect a 22 megohm (red-red-blue) resistor between lugs 5 (S-3) and 6 (NS) of switch FA.
- () Connect a 100 megohm (brown-black-violet) resistor between lugs 6 (S-2) and 7 (S-1) of switch FA.
- () Cut one lead of a 5,6 megohm (green-blue-green) resistor to 1/2". Then connect this lead to lug 12 (NS) and the longer lead to the solder lug (S-5) on switch FA.

NOTE: The values for the following parts, to be installed on switch FA, depend on the IF frequency of the receiver you intend to use with the Scanalyzer. This frequency can be found in your receiver instruction manual. You may be able to determine this frequency by referring ahead to the Receiver Intermediate Frequency Chart on Page 51. Look up the make and model number of your receiver in this chart. If it is included, the IF frequency will be shown in the third column, across from the model number.

- () Locate the IF frequency for your receiver on the following chart (Chart 1). Then determine the values for resistors R1 and R2; these resistors are shown across from your IF frequency in the second and third columns. For IF's that are not listed, use the resistor values for the closest listed frequency.
- () Refer to Detail 5A, and connect resistor R1 between lugs 10 (NS) and 12 (S-2) of switch FA.
- () Connect resistor R2 between lugs 8 (S-2) and 10 (S-2) of switch FA.

CHART 1

RECEIVER IF (kHz)	R1 (10 kHz)	R2 (50 kHz)
455	820 KΩ (gray-red-yellow)	100 KΩ (brown-black-yellow)
1000	10 M (brown-black-blue)	100 KΩ (brown-black-yellow)
1600 through 2215	10 M (brown-black-blue)	1.5 M (brown-green-green)
2445	18 M (brown-gray-blue)	1.5 M (brown-green-green)
3000 through 3055	22 M (red-red-blue)	3.3 M (orange-orange-green)
3395	22 M (red-red-blue)	5.6 M (green-blue-green)
5200 through 6000	22 M (red-red-blue)	3.3M (orange-orange-green)

Resistors are shown in ohms (K = 1,000 Ω, M = 1,000,000 Ω)

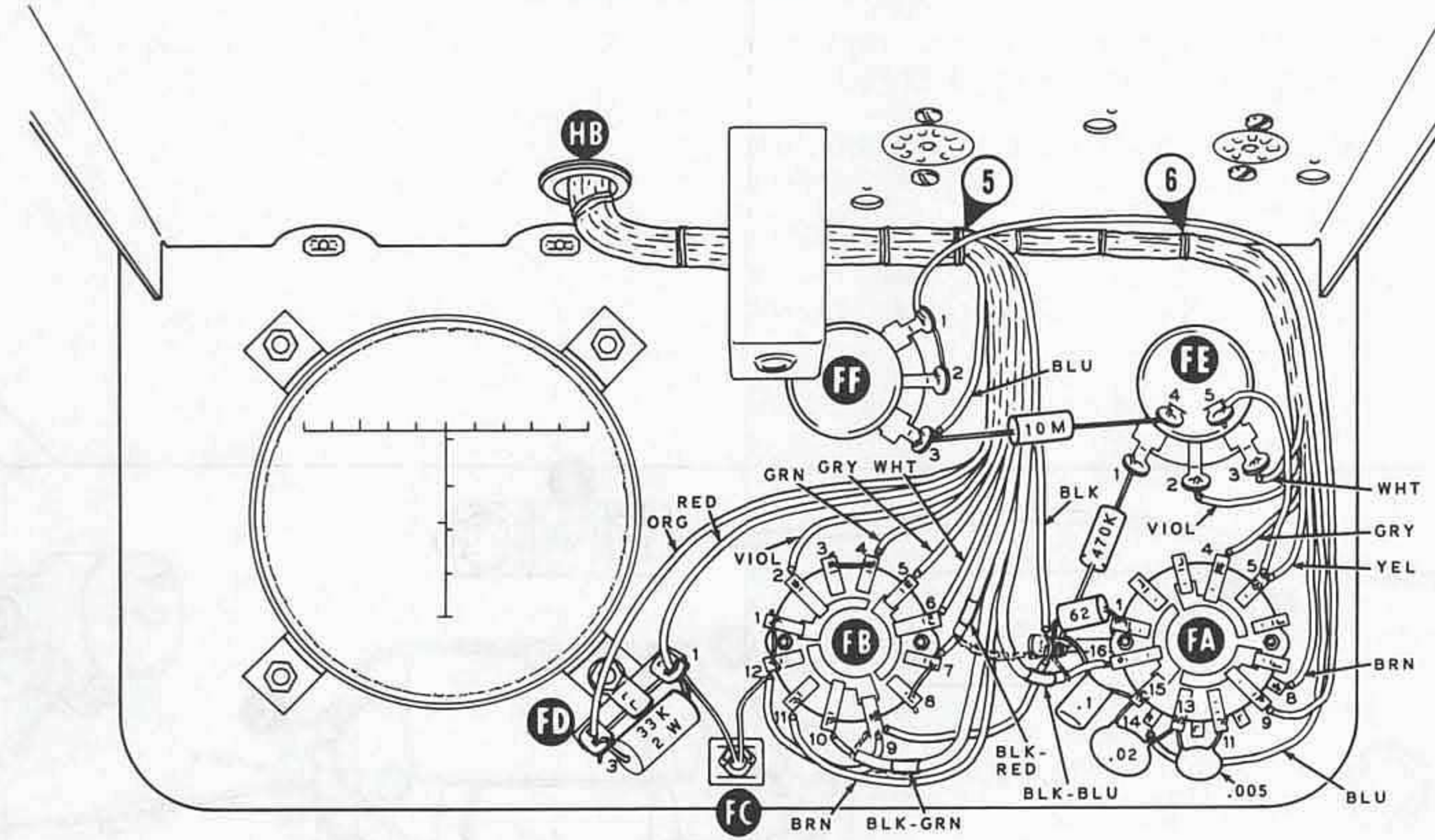

PICTORIAL 5

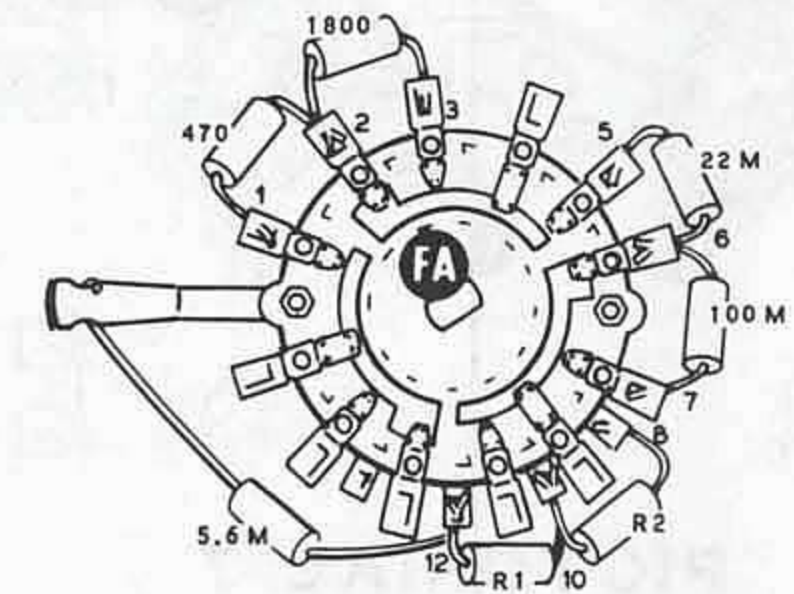

Detail 5A

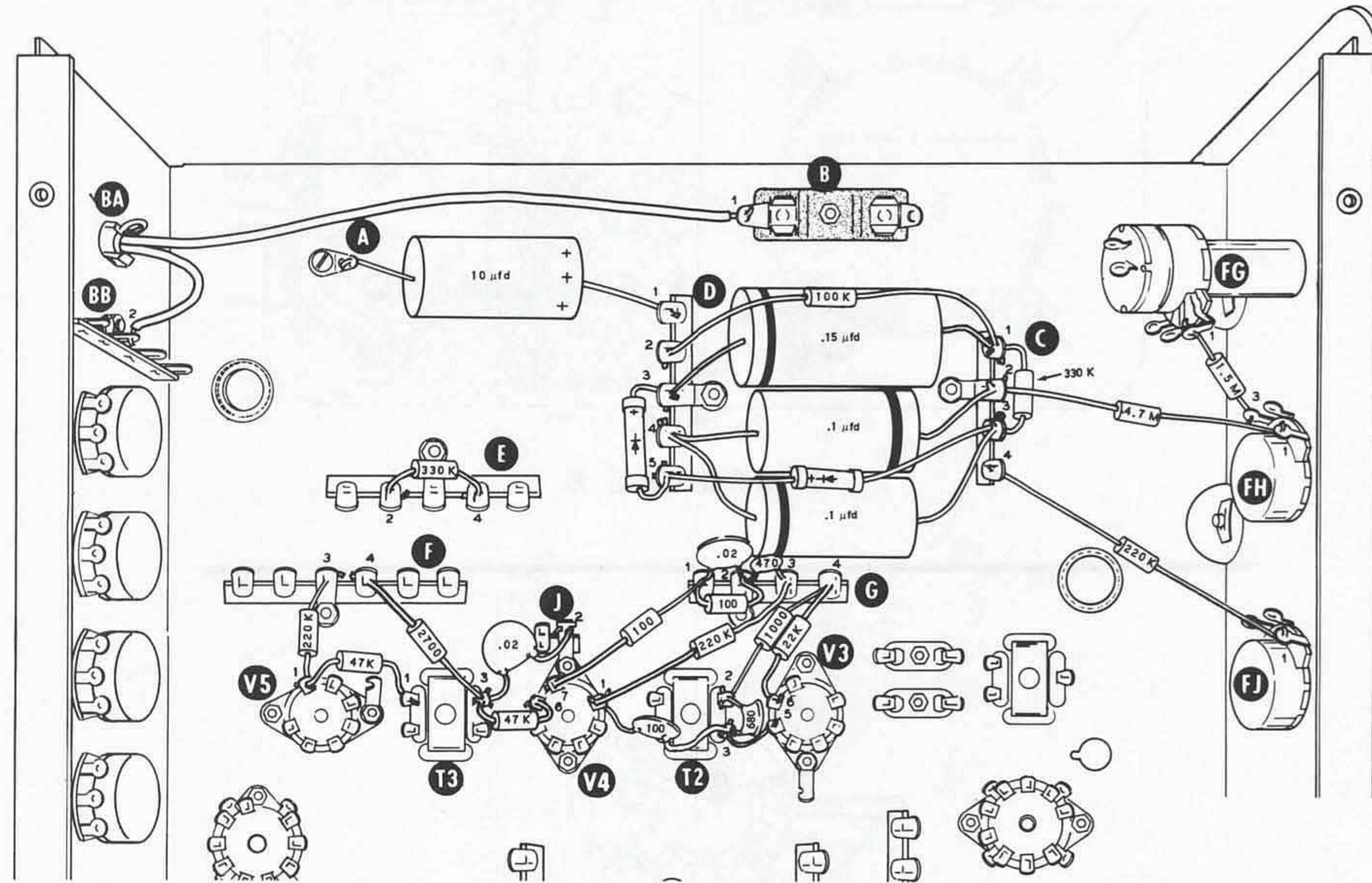

PICTORIAL 7

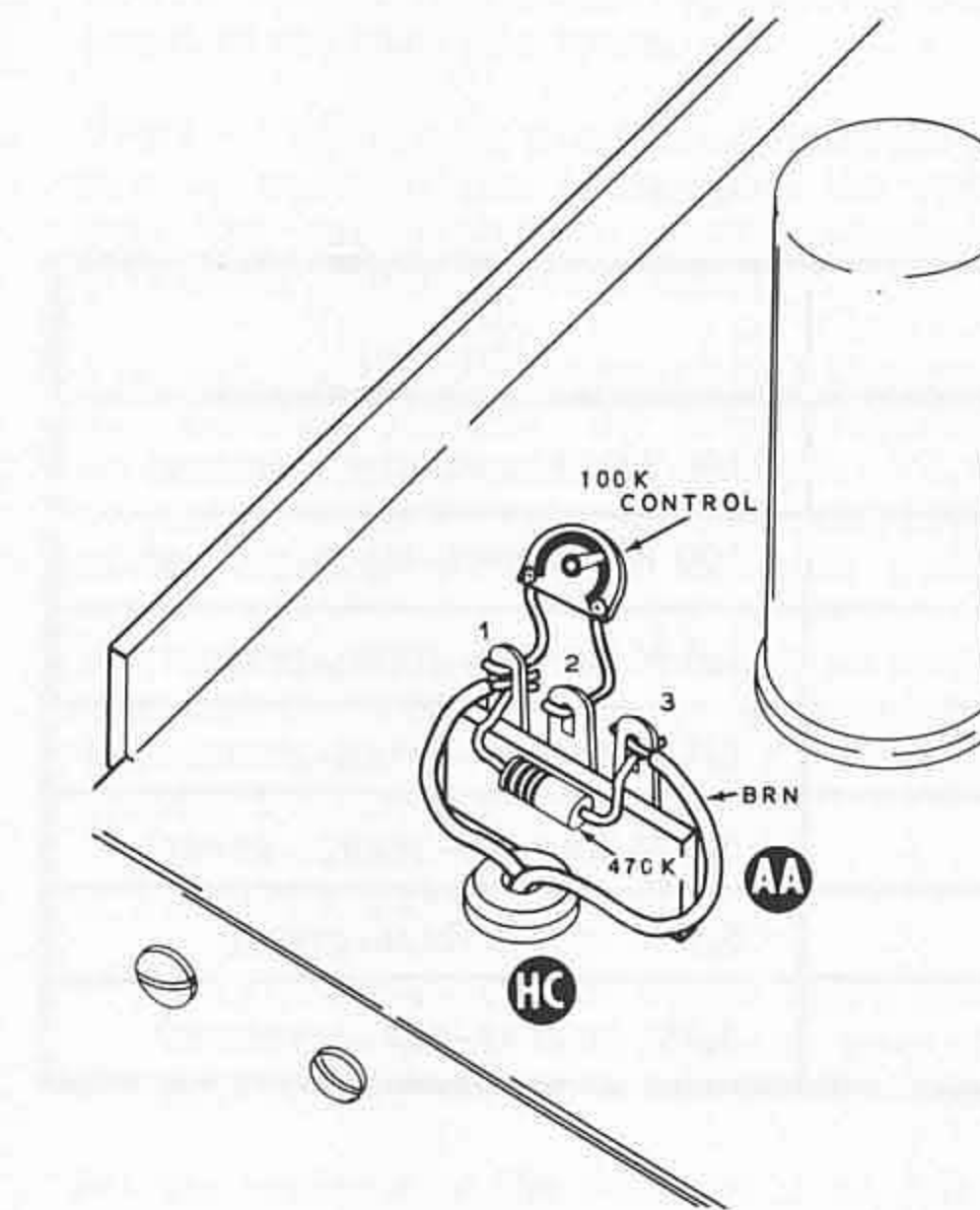

PICTORIAL 6

Refer to Pictorial 6 for the following steps.

- () Connect the free end of the brown wire extending from grommet HC to lug 3 of terminal strip AA (NS).
- () Connect the free end of the other wire extending from grommet HC to lug 1 of terminal strip AA (NS).
- () Connect a 470 KΩ (yellow-violet-yellow) resistor between lugs 1 (NS) and 3 (S-2) of terminal strip AA.
- () Connect a 100 KΩ control with wire leads (#10-166) between lugs 1 (S-3) and 2 (S-1) of terminal strip AA.

COMPONENT INSTALLATION

Refer to Pictorial 7 for the following steps.

- () Connect the positive (+) lead of a 10 μfd electrolytic capacitor to lug 1 of terminal strip D (S-2) and the other lead to solder lug A (S-1).

NOTE: When connecting tubular capacitors, position the banded end as shown in Pictorial 7.

- () Connect a .15 μfd tubular capacitor from lug 1 of terminal strip C (NS) to lug 3 of terminal strip D (NS).
- () Connect a .1 μfd tubular capacitor from lug 2 of terminal strip C (NS) to lug 4 of terminal strip D (NS).
- () Connect a .1 μfd tubular capacitor from lug 3 of terminal strip C (NS) to lug 4 of terminal strip D (S-3).

NOTE: The positive end of each selenium diode is marked with either a plus (+) sign or a color dot.

- () Connect the lead from the positive (+) end of a selenium diode (#57-44) to lug 3 (S-2) and the other lead to lug 5 (NS) of terminal strip D.
- () Connect the lead from the positive (+) end of a selenium diode (#57-44) to lug 5 of terminal strip D (S-3) and the other lead to lug 3 (NS) of terminal strip C (NS).

- () Connect a 330 KΩ (orange-orange-yellow) resistor between lugs 3 (S-3) and 1 (NS) of terminal strip C.
- () Connect a 100 KΩ (brown-black-yellow) resistor from lug 1 of terminal strip C (S-4) to lug 2 of terminal strip D (S-2).
- () Connect a 1.5 megohm (brown-green-green) resistor from lug 1 of control FG (S-1) to lug 3 of control FH (S-1).
- () Connect a 4.7 megohm (yellow-violet-green) resistor from lug 1 of control FH (S-1) to lug 2 of terminal strip C (S-3).
- () Connect a 220 KΩ (red-red-yellow) resistor from lug 4 of terminal strip C (S-2) to lug 1 of control FJ (S-1).

- () Connect a 330 K Ω (orange-orange-yellow) resistor between lugs 2 (S-4) and 4 (S-2) of terminal strip E.
 - () Connect a 220 K Ω (red-red-yellow) resistor from lug 3 of terminal strip F (S-3) to lug 1 of tube socket V5 (NS).
 - () Connect a 47 K Ω (yellow-violet-orange) resistor from lug 1 of tube socket V5 (S-3) to lug 1 of IF transformer T3 (NS).
 - () Connect a 2700 Ω (red-violet-red) resistor from lug 4 of terminal strip F (S-3) to lug 3 of IF transformer T3 (NS).
 - () Connect a .02 μ fd disc capacitor from lug 3 of IF transformer T3 (NS) to lug 2 of terminal strip J (NS).
 - () Connect a 47 K Ω (yellow-violet-orange) resistor from lug 3 of IF transformer T3 (S-4) to lug 6 of tube socket V4 (NS).
 - () Connect a 100 Ω (brown-black-brown) resistor from lug 7 of tube socket V4 (S-1) to lug 1 of terminal strip G (NS).
 - () Connect a 100 Ω (brown-black-brown) resistor between lugs 1 (NS) and 2 (NS) of terminal strip G.
 - () Connect a .02 μ fd disc capacitor between lugs 1 (S-4) and 2 (NS) of terminal strip G.
 - () Connect a 470 pf disc capacitor between lugs 2 (NS) and 3 (NS) of terminal strip G.
 - () Connect a 220 K Ω (red-red-yellow) resistor from lug 3 of terminal strip G (S-3) to lug 1 of tube socket V4 (NS).
 - () Place one lead of a 680 pf resin capacitor through lug 3 of IF transformer T2 (NS) to lug 5 of tube socket V3 (S-1). Connect the other lead of this capacitor to lug 2 of T2 (NS).
 - () Connect a 100 pf disc capacitor from lug 1 of tube socket V4 (S-2) to lug 3 of IF transformer T2 (S-3).
 - () Connect a 1000 Ω (brown-black-red) resistor from lug 2 of IF transformer T2 (NS) to lug 4 of terminal strip G (NS).
 - () Connect a 22 K Ω (red-red-orange) resistor from lug 4 of terminal strip G (S-3) to lug 6 of tube socket V3 (NS).
- NOTE: The line cord and plug supplied with this kit is intended primarily for 120 volt AC service. If the kit is wired for 240 volt AC service, check your local electrical code for the necessary type of line cord and plug, and the connection of the third wire, when required.
- () Separate the line cord wires for a total of 5-1/2". Cut 3" from the end of one of the line cord wires. Remove 1/4" of insulation from this wire. Now twist the wire strands together at the bared end of each wire; then melt a small amount of solder on the bared ends to hold the wire strands together.
 - () Place the prepared end of the line cord through hole BA and connect the long wire to lug 1 of fuse block B (S-1). Connect the short wire to lug 2 of terminal strip BB (S-3) or, if wired for 240 volts operation, (S-2).
 - () Refer to Detail 7A and install the line cord strain relief in hole BA.

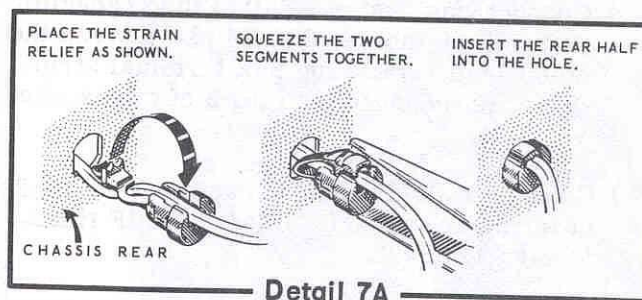

Refer to Pictorial 8 (fold-out from Page 25) for the following steps.

- () Connect a 1 μ fd resin (brown-black-green) capacitor from lug 1 of terminal strip F (S-2) to lug 1 of tube socket V6 (NS).
- () Connect a 220 K Ω (red-red-yellow) resistor from lug 1 of tube socket V6 (S-3) to lug 1 of terminal strip P (NS).

- () Wrap one lead of a 470 pf disc capacitor around solder lug H (S-2) and then place it through lug 2 (NS) to lug 3 (S-1) of tube socket V5. Connect the other lead of this capacitor to lug 1 of IF transformer T3 (NS).
- () Connect a 1-1/2" hookup wire from lug 6 of V5 (S-1) to lug 2 of IF transformer T3 (S-1).
- () Connect a 1" bare wire from lug 2 (S-3) to lug 5 (S-1) of tube socket V5.
- () Connect a 100 K Ω (brown-black-yellow) resistor from lug 2 of terminal strip F (S-2) to lug 1 of IF transformer T3 (S-3).
- () Connect a 33 K Ω (orange-orange-orange) resistor from lug 5 of terminal strip F (S-2) to lug 1 of terminal strip J (NS).
- () Connect a 10 K Ω (brown-black-orange) resistor from lug 6 of terminal strip F (S-2) to lug 1 of terminal strip J (NS).
- () Connect a 1" bare wire from lug 6 of V4 (NS) to lug 1 of terminal strip J (S-3).
- () Connect a 3/4" bare wire from lug 5 of V4 (S-1) to lug 4 of IF transformer T3 (S-1).
- () Connect one lead of a 470 pf disc capacitor to lug 6 of tube socket V4 (S-3). Wrap the other lead around lug 2 of terminal strip J (S-4) and connect it to lug 2 of tube socket V4 (S-1).
- () Connect a .02 μ fd disc capacitor from lug 2 of terminal strip G (S-5) to lug 2 of IF transformer T2 (S-3).
- () Place one lead of a .02 μ fd disc capacitor through lug 2 (S-3) to lug 7 (S-1) of tube socket V3. Connect the other lead of this capacitor to solder lug K (NS).
- () Connect a .02 μ fd disc capacitor from lug 6 of tube socket V3 (S-2) to solder lug K (S-2).
- () Connect a 3/4" bare wire from lug 2 of crystal socket Y2 (S-1) to lug 1 of IF transformer T1 (S-1).
- () Place one lead of a 5 pf disc capacitor through lug 2 of crystal socket Y1 (S-2) to lug 2 of IF transformer T1 (S-1). Connect the other lead of this capacitor to lug 6 of tube socket V2 (NS).
- () Place one lead of a 1-1/2" bare wire through ground lug 12 (NS) to lug 5 (NS) of tube socket V2. Connect the other end of this wire to lug 3 of IF transformer T1 (S-1).
- () Connect a 47 K Ω (yellow-violet-orange) resistor from lug 6 of tube socket V2 (S-2) to lug 1 of terminal strip L (NS).
- () Connect a .02 μ fd disc capacitor from ground lug 11 of tube socket V2 (NS) to lug 1 of terminal strip L (NS).
- () Connect a 150 K Ω (brown-green-yellow) resistor from lug 3 of tube socket V2 (NS) to lug 1 of terminal strip L (NS).
- () Connect a 1000 Ω (brown-black-red) resistor from lug 1 of terminal strip L (S-4) to lug 1 of terminal strip M (NS).
- () Connect a 1000 Ω (brown-black-red) resistor from lug 1 of terminal strip M (S-3) to lug 6 of terminal strip L (NS).
- () Place one lead of a 47 K Ω (yellow-violet-orange) resistor through lug 1 of crystal socket Y1 (S-2), and through lug 1 of crystal socket Y2 (S-2), to lug 1 of tube socket V3 (S-1). Connect the other lead of this resistor to lug 2 of terminal strip L (NS).
- () Connect a 15 K Ω (brown-green-orange) resistor from lug 2 of tube socket V2 (NS) to ground lug 11 of tube socket V2 (S-2).
- () Connect a 4700 Ω (yellow-violet-red) resistor from lug 1 of tube socket V2 (NS) to lug 3 of terminal strip L (S-2).
- () Connect a 100 K Ω (brown-black-yellow) resistor between lugs 9 (NS) and ground lug 10 (NS) of tube socket V2.
- () Connect a 51 Ω (green-brown-black) resistor from lug 2 of tube socket V1 (S-2) to solder lug Z (NS).

- () Wrap one lead of a .02 μ fd disc capacitor around solder lug Z (NS) and through lug 3 (NS) to lug 7 (S-1) of tube socket V1. Connect the other lead to lug 4 of V1 (S-3).
- () Connect a 1000 Ω (brown-black-red) 2 watt resistor from lug 2 of terminal strip M (NS) to lug 1 of terminal strip X (NS).
- () Connect a 1000 Ω (brown-black-red) 1 watt resistor from lug 2 of terminal strip N (NS) to lug 1 of terminal strip W (NS).
- () Connect a 5.6 megohm (green-blue-green) resistor between lugs 1 (S-2) and 2 (NS) of terminal strip N.
- () Connect a 3.3 megohm (orange-orange-green) resistor from lug 2 of terminal strip N (NS) to lug 4 of terminal strip P (S-2).
- () Connect a .22 μ fd resin capacitor between lugs 2 (NS) and 3 (NS) of terminal strip P.
- () Connect a 33 K Ω (orange-orange-orange) 1 watt resistor from lug 2 of terminal strip P (NS) to lug 3 of tube socket V6 (NS).
- () Connect an NE-83 neon lamp between lugs 2 (S-3) and 3 (S-3) of terminal strip P.
- () Connect a 1-1/4" length of hookup wire between lugs 3 (S-2) and 8 (S-1) of tube socket V6.
- () Connect a .02 μ fd disc capacitor between lug 7 (NS) and ground lug 10 (S-1) of tube socket V6.
- () Connect a 3.3 megohm (orange-orange-green) resistor from lug 7 of tube socket V6 (NS) to lug 3 of control BF (NS).
- () Connect a .02 μ fd disc capacitor from lug 7 of tube socket V6 (S-4) to lug 3 of control BF (S-2).

- () Connect a 10 K Ω (brown-black-orange) 2 watt resistor between lugs 1 (S-2) and 3 (S-3) of electrolytic capacitor S.

NOTE: When installing silicon diodes, be sure to place the cathode end as directed. The cathode end is marked with either a color end, color dot, or color band as shown in Detail 8A.

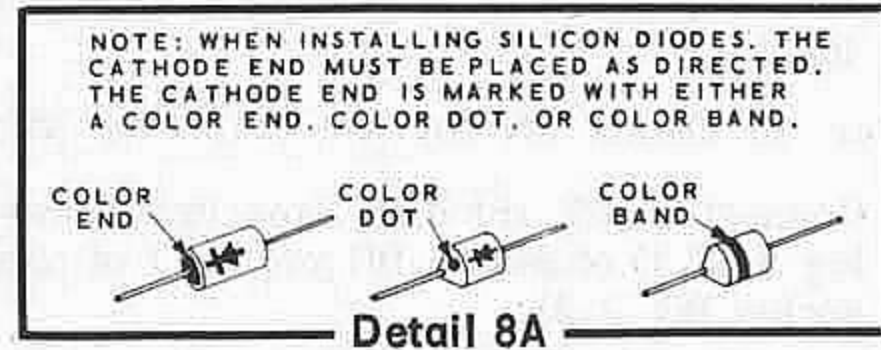

- () Connect the cathode lead of a silicon diode to lug 3 (NS) and the other lead to lug 2 (NS) of terminal strip R.
- () Connect the cathode lead of a silicon diode to lug 3 (S-2) and the other lead to lug 5 (NS) of terminal strip R.
- () Connect the cathode lead of a silicon diode to lug 5 (S-4) and the other lead to lug 4 (NS) of terminal strip R.
- () Connect the cathode lead of a silicon diode to lug 2 (S-4) and the other lead to lug 4 (NS) of terminal strip R.
- () Connect the cathode lead of a silicon diode to lug 1 (NS) and the other lead to lug 2 (S-2) of terminal strip U.
- () Connect the cathode lead of a silicon diode to lug 3 (NS) and the other lead to lug 1 (S-2) of terminal strip U.
- () Connect the cathode lead of a silicon diode to lug 4 (NS) and the other lead to lug 3 (S-3) of terminal strip U.
- () Connect the cathode lead of a silicon diode to lug 1 of terminal strip W (NS) and the other lead to lug 4 of terminal strip U (S-2).

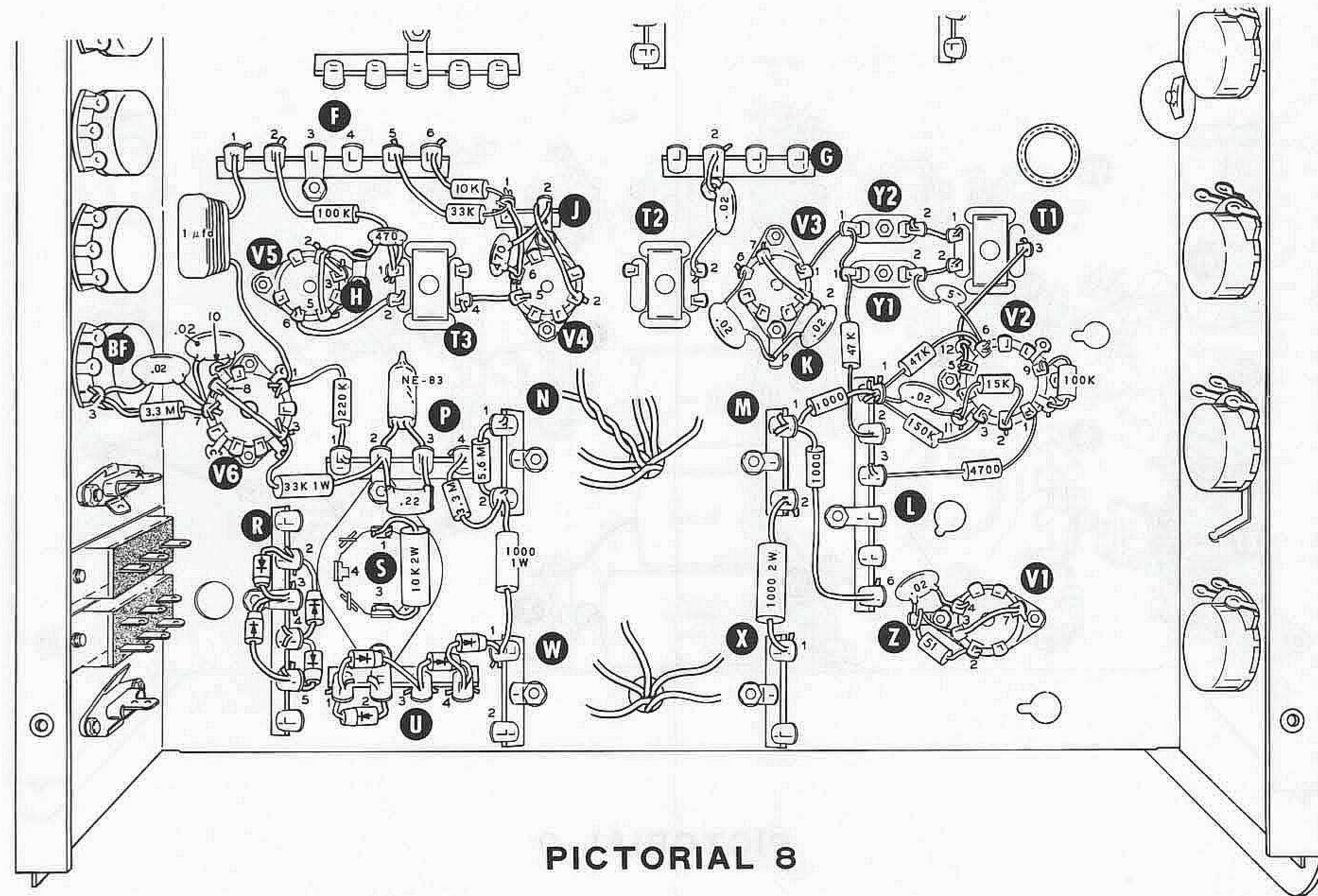

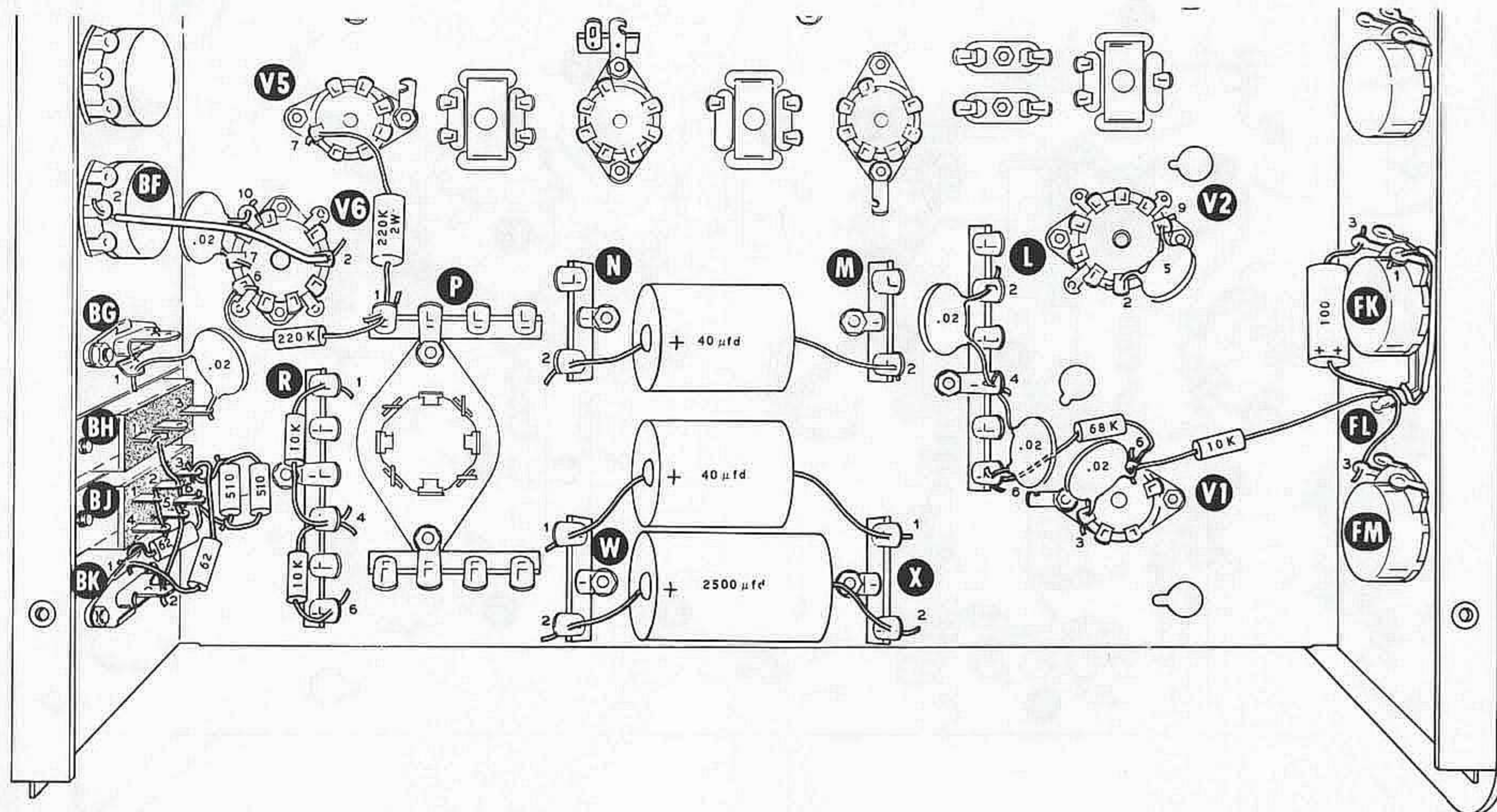

PICTORIAL 9

Refer to Pictorial 9 for the following steps.

- () Connect a 220 K Ω 2 watt (red-red-yellow) resistor from lug 7 of tube socket V5 (S-2) to lug 1 of terminal strip P (NS).
- () Connect a 220 K Ω (red-red-yellow) resistor from lug 1 of terminal strip P (S-5) to lug 6 of tube socket V6 (S-2).
- () Connect a 2-1/2" hookup wire from lug 2 of tube socket V6 (S-1) to lug 2 of control BF (S-1).

Refer to Detail 9A for the following steps.

- () Connect a .02 μ fd disc capacitor between lug 3 (S-1) of switch BH and lug 1 of phono socket BG (S-3).
- () Connect a 3/4" bare wire from lug 1 of switch BH (S-1) to lug 2 of switch BJ (S-1).
- () Connect a 1/2" bare wire between lugs 1 (S-1) and 4 (S-1) of switch BJ.
- () Connect a 62 Ω (blue-red-black) resistor from lug 6 of switch BJ (NS) to lug 1 of phono socket BK (NS).
- () Connect a 62 Ω (blue-red-black) resistor from lug 3 of switch BJ (NS) to lug 1 of phono socket BK (S-2).
- () Connect a 1" bare wire from lug 5 of switch BJ (S-1) to lug 2 of phono socket BK (S-1).
- () Refer to Detail 9B and prepare a combination of two 510 Ω (green-brown-brown) resistors. Connect this resistor combination between lugs 3 (S-2) and 6 (S-2) of switch BJ.

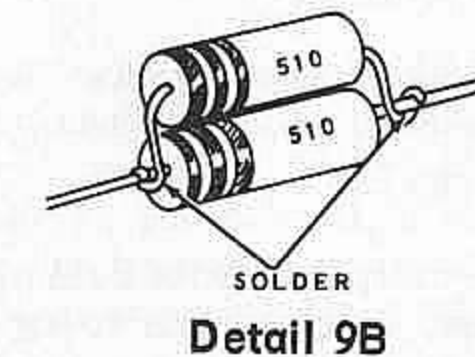

Detail 9B

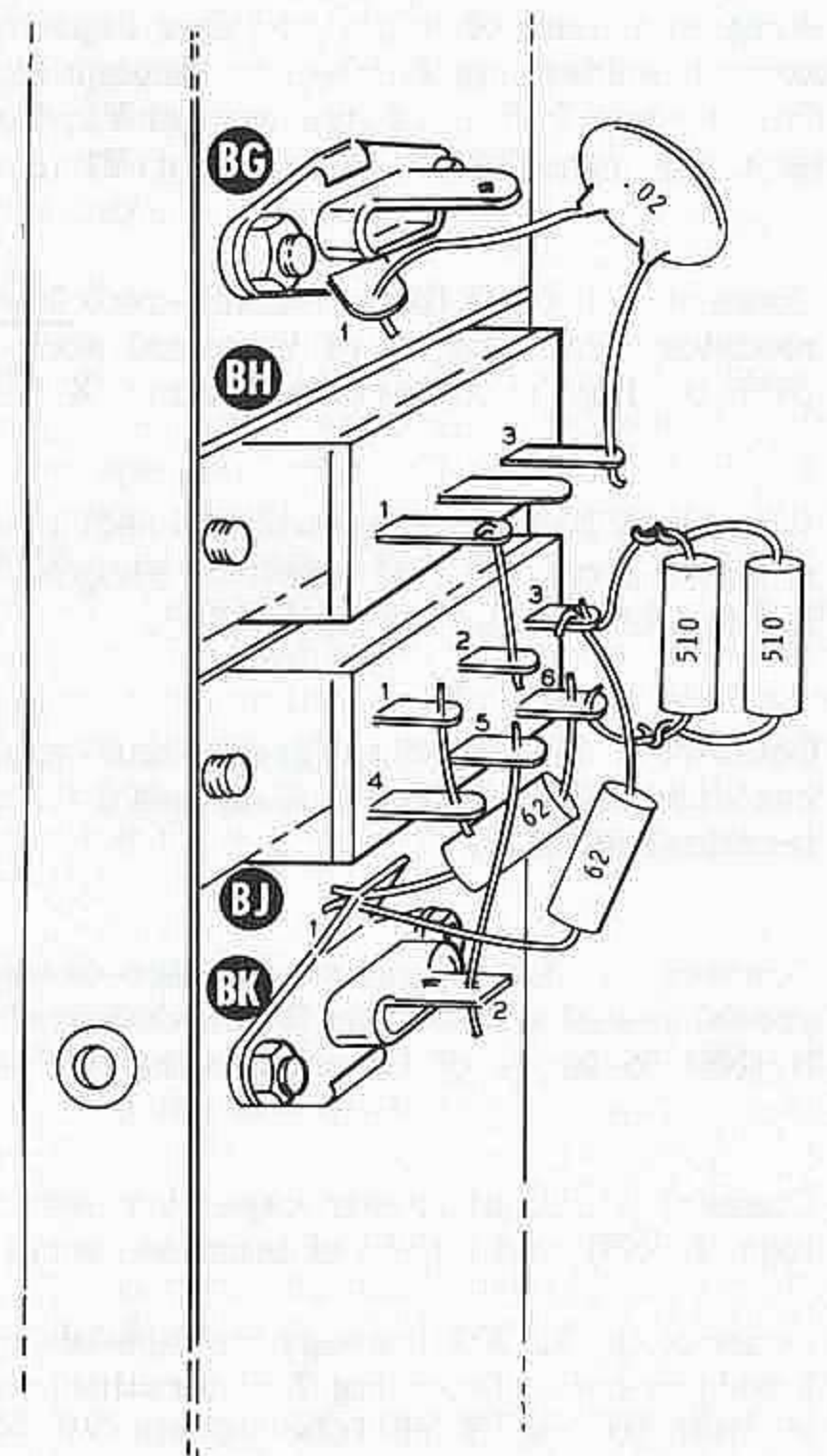

Detail 9A

Refer to Pictorial 9 for the following steps.

- () Connect a 10 K Ω (brown-black-orange) resistor between lugs 1 (S-2) and 4 (NS) of terminal strip R.

- () Connect a 10 K Ω (brown-black-orange) resistor between lugs 4 (S-5) and 6 (S-2) of terminal strip R.
- () Connect the positive (+) lead of a 2500 μ fd electrolytic capacitor to lug 2 of terminal strip W (S-2) and the other lead to lug 2 of terminal strip X (S-2).
- () Connect the positive (+) lead of a 40 μ fd electrolytic capacitor to lug 1 of terminal strip W (S-3) and the other lead to lug 1 of terminal strip X (S-4).
- () Connect the positive (+) lead of a 40 μ fd electrolytic capacitor to lug 2 of terminal strip N (S-5) and the other lead to lug 2 of terminal strip M (S-3).
- () Connect the positive (+) lead of 100 μ fd electrolytic capacitor to solder lug FL (NS) and the other lead to lug 3 of control FK (S-2).
- () Connect a 68 K Ω (blue-gray-orange) resistor from lug 6 of tube socket V1 (NS) to lug 6 of terminal strip L (NS).
- () Connect a 10 K Ω (brown-black-orange) resistor from lug 6 of tube socket V1 (NS) to solder lug FL (NS).
- () Connect a 3" hookup wire between lug 1 of control FK (S-1) and solder lug FL (NS).
- () Connect a 1" bare wire between lug 3 of control FM (S-1) and solder lug FL (S-5).
- () Connect a .02 μ fd disc capacitor between lugs 6 (S-3) and 3 (S-3) of tube socket V1.
- () Connect a 5 pf disc capacitor between lugs 2 (NS) and 9 (NS) of tube socket V2.
- () Connect a .02 μ fd disc capacitor between lugs 2 (S-3) and 4 (NS) of terminal strip L.
- () Connect a .02 μ fd disc capacitor between lugs 4 (NS) and 6 (NS) of terminal strip L.

This completes the basic wiring of your kit. The rest of the wiring in your Scanalyzer depends upon the IF frequency of your receiver. This frequency was determined in a previous step on Page 20, when you selected the values for resistors R1 and R2.

OPTIONAL IF WIRING

Three similar sets of wiring instructions are given on the following pages, under the following three titles:

455 kHz

1000 kHz, 1600 kHz, 1680 kHz, 2075 kHz, 2215 kHz, 2445 kHz, 3000 kHz, 3055 kHz, 5200 kHz, or 6000 kHz.

3395 kHz.

Use only the set of wiring instructions that include the IF frequency of your receiver. (NOTE: All Heath SB-series receivers have an IF frequency of 3395 kHz.)

455 kHz

Refer to Pictorial 10 for the following steps.

- () Connect a .02 μ fd disc capacitor between lugs 3 (S-2) and 5 (S-2) of V2.
- () Locate the oscillator coil (#40-775) and mount it at L3 as shown in Detail 10A. Note the position of the locating tab.

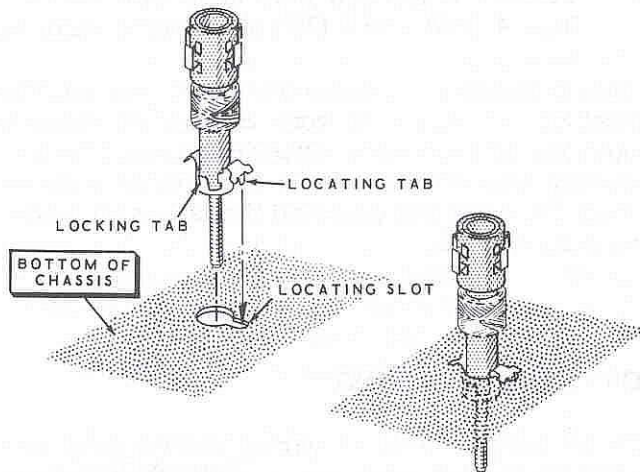

Detail 10A

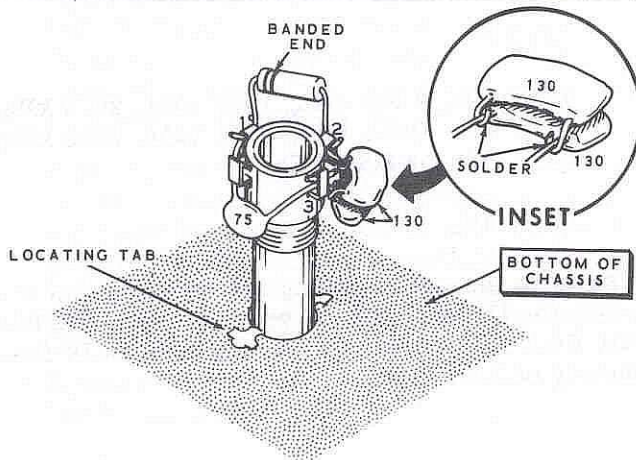

Detail 10B

Refer to Detail 10B for the following four steps:

- () Solder the leads of one 130 pf resin capacitor to the leads of another 130 pf resin capacitor as shown in the inset drawing. This forms a 260 pf capacitor combination.
- () Connect the 260 pf capacitor combination between lugs 2 (NS) and 3 (NS) of coil L3.

- () Connect the lead from the banded end of the Varicap diode (#56-49) to lug 1 (NS) and the other lead to lug 2 (NS) of oscillator coil L3.
 - () Connect a 75 pf disc capacitor between lugs 1 (NS) and 3 (NS) of oscillator coil L3. Position the body of this capacitor against the coil windings as shown.
 - () Connect a 47 K Ω (yellow-violet-orange) resistor from lug 2 of coil L3 (NS) to lug 2 of control FK (S-1).
 - () Connect a 10 K Ω (brown-black-orange) resistor from lug 2 of coil L3 (NS) to lug 2 of control FJ (NS).
- NOTE: When soldering the wires at lugs 2 and 1 of coil L3, hold the leads of the Varicap diode with long-nose pliers to carry away the heat. The handles of the pliers may be held together with a heavy rubber band.
- () Connect a 22 K Ω (red-red-orange) resistor from lug 2 of coil L3 (S-5) to ground lug 13 of tube socket V2 (NS).

- () Connect a 1-1/4" bare wire from lug 1 of coil L3 (NS) to ground lug 13 of tube socket V2 (S-2).
- () Connect a 100 pf disc capacitor from lug 1 of coil L3 (S-4) to lug 2 of control FJ (S-2).
- () Connect a 1/2" bare wire from lug 4 of coil L3 (S-1) to lug 8 of tube socket V2 (S-1).
- () Connect a 115 pf resin capacitor from lug 3 of coil L3 (S-3) to lug 9 of tube socket V2 (S-3).
- () Mount a #40-590 coil at L2. Note the position of the locating tab.
- () Connect a 470 pf disc capacitor between lugs 1 (NS) and 2 (NS) of coil L2.
- () Connect a .02 μ fd disc capacitor from lug 1 of coil L2 (S-2) to lug 2 of tube socket V2 (S-3).
- () Connect a .02 μ fd disc capacitor between lug 1 (S-2) and ground lug 10 (S-2) of tube socket V2.
- () Connect a 1/2" bare wire between lug 7 (S-1) and ground lug 12 (S-3) of tube socket V2.

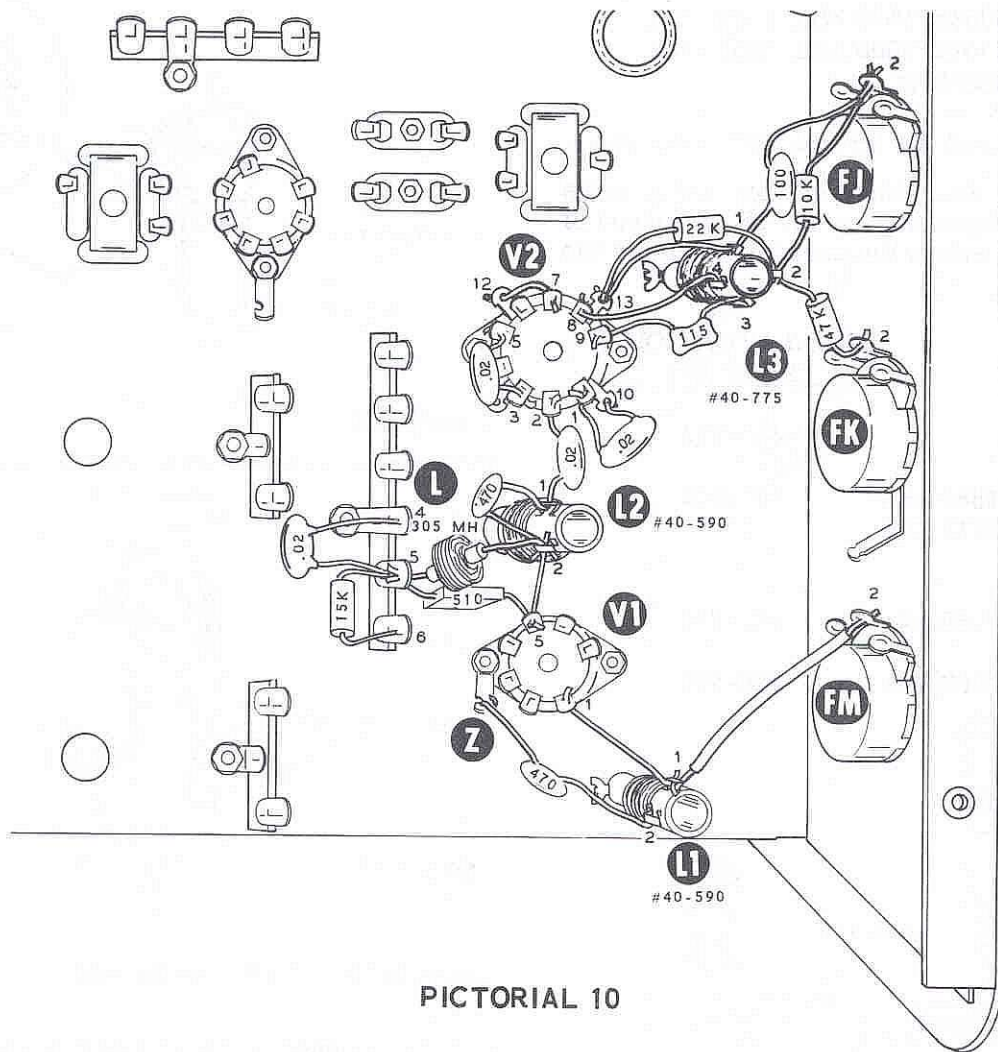

PICTORIAL 10

- () Connect a 510 pf molded capacitor from lug 5 of tube socket V1 (NS) to lug 5 of terminal strip L (NS).
- () Place one lead of a 305 μ H peaking coil (#45-33) through lug 2 of coil L2 (S-3) to lug 5 of tube socket V1 (S-2). Connect the other lead of this coil to lug 5 of terminal strip L (NS).
- () Mount a #40-590 coil at L1. Note the position of the locating tab.
- () Connect a 1" bare wire from lug 1 of tube socket V1 (S-1) to lug 1 of coil L1 (NS).
- () Connect a 1-3/4" hookup wire from lug 1 of coil L1 (S-2) to lug 2 of control FM (S-1).
- () Connect a 470 pf disc capacitor from lug 2 of coil L1 (S-1) to solder lug Z (S-5).
- () Connect a .02 μ fd disc capacitor between lugs 4 (S-3) and 5 (NS) of terminal strip L.
- () Connect a 15 K Ω (brown-green-orange) resistor between lugs 5 (S-4) and 6 (S-4) of terminal strip L.

This completes the wiring of the Scanalyzer. Tip and shake the unit to dislodge any wire clippings or bits of solder that may have fallen unnoticed into the assembly. Carefully examine all connections to be sure they are properly made, and that no short circuits exist between wires or components. Then proceed to CRT Installation on Page 34.

There will be some parts left over that would have been used in one of the other optional IF wiring instructions. Save these parts. You may someday want to change the wiring for use with a different IF frequency.

1000 kHz, 1600 kHz, 1680 kHz, 2075 kHz,
2215 kHz, 2445 kHz, 3000 kHz, 3055 kHz,
5200 kHz, or 6000 kHz.

Refer to Pictorial 11 for the following steps.

NOTE: One of four different oscillator coils will be used, depending on the IF frequency of your receiver. Select the correct coil from the following chart.

IF FREQ	OSCILLATOR COIL PART NO.
1000 kHz	#40-775
1600 kHz, 1680 kHz 2075 kHz, 2215 kHz 2445 kHz	#40-808
3000 kHz, 3055 kHz	#40-776
5200 kHz, 6000 kHz	#40-807

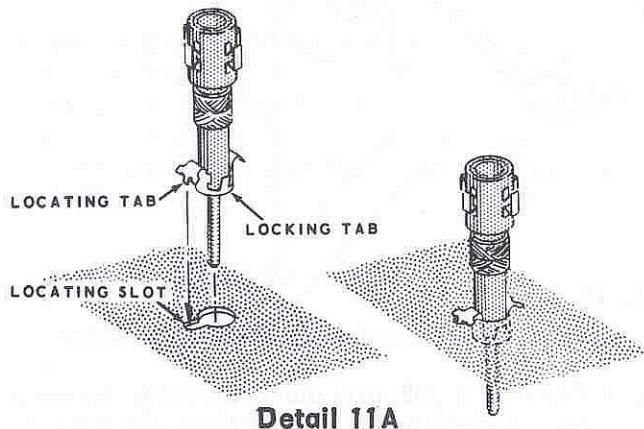

Detail 11A

- () Install the selected oscillator coil at L3 as shown in Detail 11A. Note the position of the locating tab.

NOTE: Perform only two of the following steps. If the IF frequency of your receiver is 1000 kHz, perform only steps 1 and 2, and omit steps 3 and 4. If the receiver IF frequency is between 1600 and 6000 kHz, omit steps 1 and 2 and perform only steps 3 and 4.

Refer to Detail 11B for the following two steps.

- () 1. Prepare two 130 pf capacitors, as shown, to form a 260 pf capacitor.
- () 2. Connect this capacitor combination from lug 2 (NS) to lug 3 (NS) of coil L3.

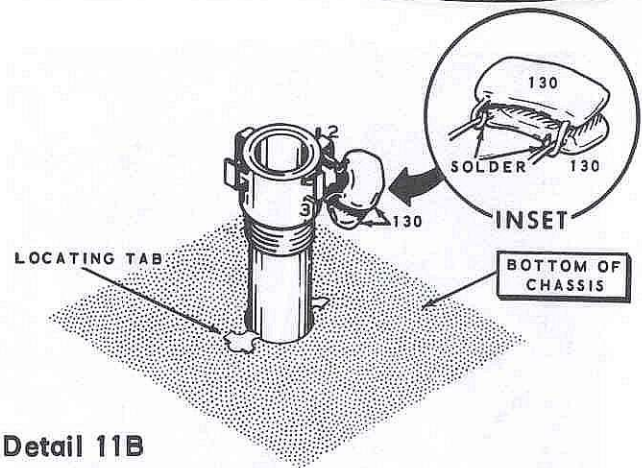

Detail 11B

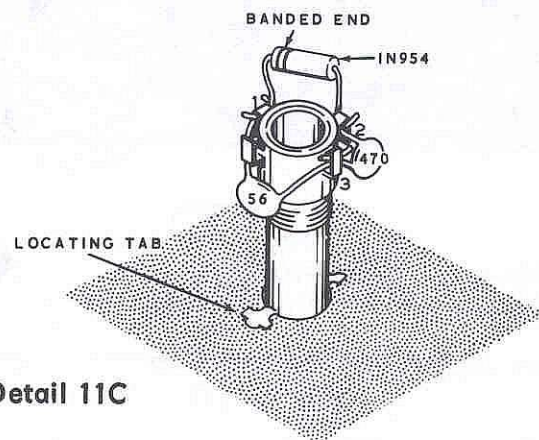

Detail 11C

Refer to Detail 11C for the following two steps.

- () 3. Connect a 470 pf disc capacitor between lugs 2 (NS) and 3 (NS) of coil L3.
- () 4. Connect a 56 pf disc capacitor between lugs 1 (NS) and 3 (NS) of coil L3. Position the body of the capacitor down against the coil windings as shown.
- () Connect the lead from the banded end of a Varicap diode to lug 1 (NS) and the other lead to lug 2 (NS) of coil L3. See Detail 11C.
- () Connect a 10 K Ω (brown-black-orange) resistor from lug 2 of coil L3 (NS) to lug 2 of control FJ (NS).
- () Connect a 47 K Ω (yellow-violet-orange) resistor from lug 2 of coil L3 (NS) to lug 2 of control FK (S-1).

NOTE: When soldering the wires at lugs 2 and 1 of coil L3, hold the leads of the Varicap diode with long-nose pliers to carry away the heat. The handles of the pliers may be held together with a heavy rubber band.

- () Connect a 22 KΩ (red-red-orange) resistor from lug 2 of coil L3 (S-5) to ground lug 13 of tube socket V2 (NS).
- () Connect a 1-1/2" hookup wire from lug 13 of tube socket V2 (S-2) to lug 1 of coil L3 (NS).
- () Connect a 100 pf disc capacitor from lug 1 of coil L3 (S-4) (S-3 for 1000 kHz IF) to lug 2 of control FJ (S-2).
- () Connect a 1" bare wire from lug 4 of coil L3 (S-1) to lug 8 of tube socket V2 (S-1).
- () Connect a 115 pf resin capacitor from lug 3 of coil L3 (S-3) to lug 9 of tube socket V2 (S-3) (S-2 for 1000 kHz IF).
- () Connect a 1/2" bare wire between lug 7 (S-1) and ground lug 12 (S-3) of tube socket V2.
- () Connect a .02 μfd disc capacitor between lug 1 (S-2) and ground lug 10 (S-2) of tube socket V2.
- () Connect a .02 μfd disc capacitor between lugs 3 (S-2) and 5 (S-2) of tube socket V2.
- () Mount a #40-590 coil at L2. Note the position of the locating tab.
- () Pass one lead of a 470 pf disc capacitor through lug 2 of coil L2 (S-2) to lug 5 of tube socket V1 (NS). Connect the other lead to lug 1 of coil L2 (NS).
- () Connect a 15 KΩ (brown-green-orange) resistor from lug 5 of tube socket V1 (S-2) to lug 6 of terminal strip L (S-4).
- () Connect a .02 μfd disc capacitor from lug 2 of tube socket V2 (S-3) to lug 1 of coil L2 (S-2).
- () Mount a #40-590 coil at L1. Note the position of the locating tab.
- () Connect a 1" bare wire from lug 1 of tube socket V1 (S-1) to lug 1 of coil L1 (NS).

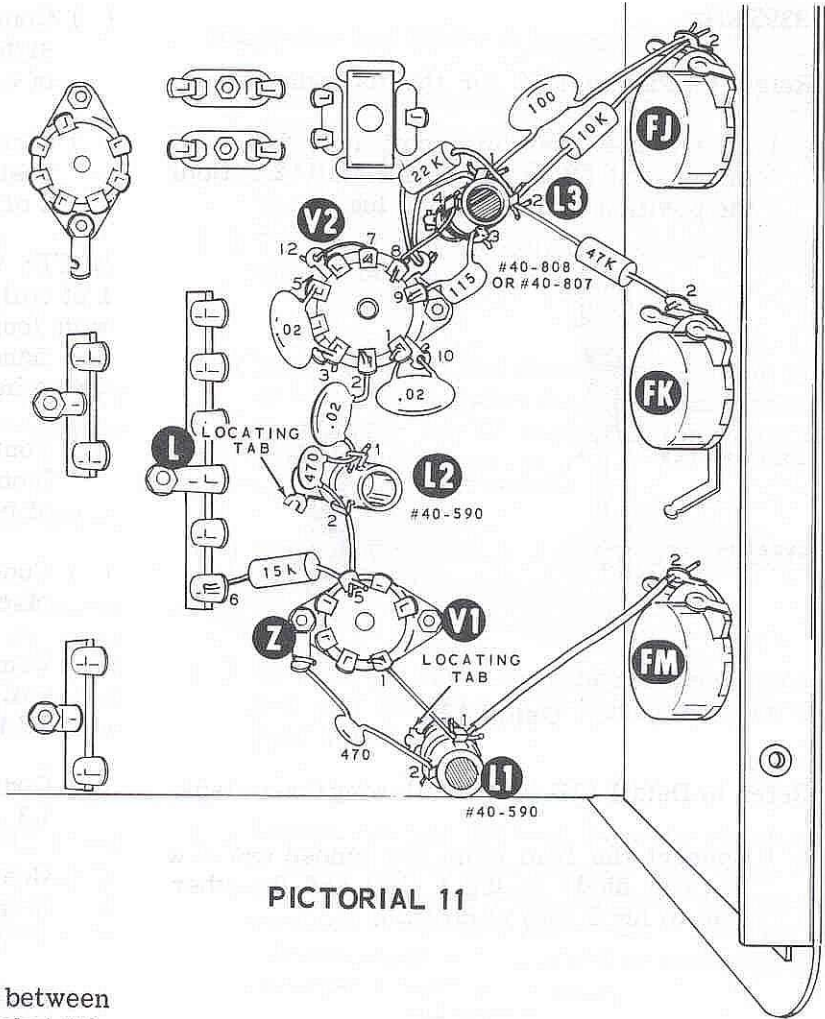

PICTORIAL 11

- () Connect a 1-3/4" hookup wire from lug 1 of coil L1 (S-2) to lug 2 of control FM (S-1).
- () Connect a 470 pf disc capacitor from lug 2 of coil L1 (S-1) to solder lug Z (S-5).
- () Solder the three leads connected to lug 4 of terminal strip L (S-3).

This completes the wiring of the Scanalyzer. Tip and shake the unit to dislodge any wire clippings or bits of solder that may have fallen unnoticed into the assembly. Carefully examine all connections to be sure they are properly made, and that no short circuits exist between wires or components. Then proceed to CRT Installation on Page 34. There will be some parts left over that would have been used in one of the other optional IF wiring instructions. Save these parts. You may someday want to change the wiring for use with a different IF frequency.

3395 kHz

Refer to Pictorial 12 for the following steps.

- () Locate the oscillator coil (#40-776) and mount it at L3 as shown in Detail 12A. Note the position of the locating lug.

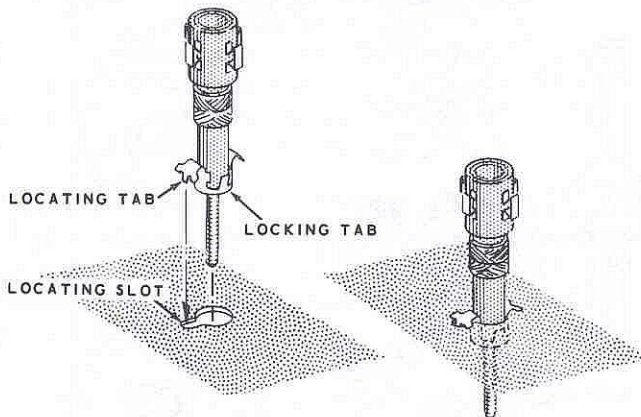

Detail 12A

Refer to Detail 12B for the following three steps.

- () Connect the lead from the banded end of a Varicap diode to lug 1 (NS) and the other lead to lug 2 (NS) of coil L3.

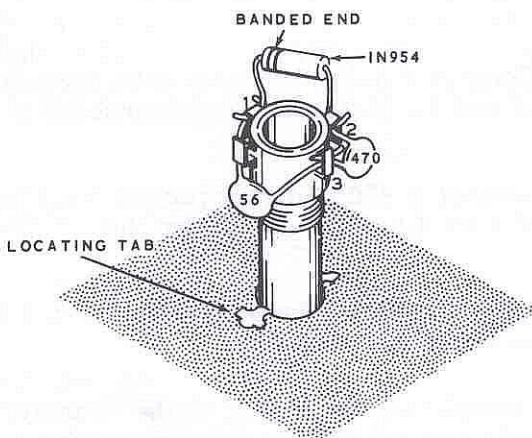

Detail 12B

- () Connect a 470 pf disc capacitor between lugs 2 (NS) and 3 (NS) of coil L3.
- () Connect a 56 pf disc capacitor between lugs 1 (NS) and 3 (NS) of coil L3. Position the body of the capacitor down against the coil windings as shown.

- () Connect a 10 K Ω (brown-black-orange) resistor from lug 2 of coil L3 (NS) to lug 2 of control FJ (NS).
- () Connect a 47 K Ω (yellow-violet-orange) resistor from lug 2 of coil L3 (NS) to lug 2 of control FK (S-1).

NOTE: When soldering the wires at lugs 2 and 1 of coil L3, hold the leads of the Varicap diode with long-nose pliers to carry away the heat. The handles of the pliers may be held together with a heavy rubber band.

- () Connect a 22 K Ω (red-red-orange) resistor from lug 2 of coil L3 (S-5) to ground lug 13 of tube socket V2 (NS).
- () Connect a 100 pf disc capacitor from lug 1 of coil L3 (NS) to lug 2 of control FJ (S-2).
- () Connect a 1-1/4" bare wire from lug 1 of coil L3 (S-4) to ground lug 13 of tube socket V2 (S-2).
- () Connect a 1" bare wire from lug 4 of coil L3 (S-1) to lug 8 of tube socket V2 (S-1).
- () Connect a 115 pf resin capacitor from lug 3 of coil L3 (S-3) to lug 9 of tube socket V2 (S-3).
- () Refer to Detail 12C and connect a 130 pf resin capacitor between lugs 1 (NS) and 2 (NS) of the bandpass coupling transformer (#52-101).

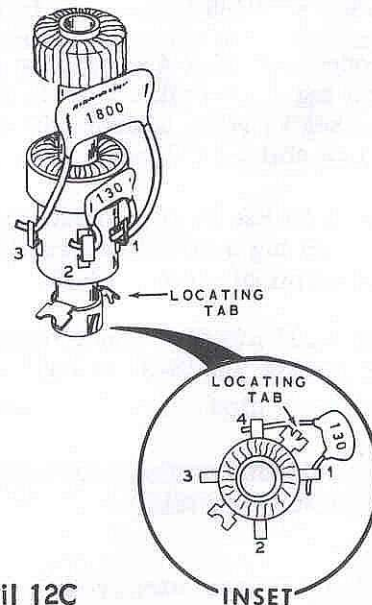

Detail 12C

- () Again refer to Detail 12C and connect an 1800 pf resin capacitor between lugs 1 (NS) and 3 (S-1) of the bandpass coupling transformer.
- () Refer to the inset on Detail 12C and mount a 130 pf resin capacitor between lugs 1 (NS) and 4 (NS) of the bandpass coupling transformer L2.
- () Mount the bandpass coupling transformer at L2.
- () Connect a .02 μ fd disc capacitor from lug 2 of transformer L2 (NS) to lug 2 of tube socket V2 (S-3).
- () Connect a 3300 Ω (orange-orange-red) resistor from lug 2 of transformer L2 (S-3) to lug 4 of terminal strip L (NS).
- () Connect a .02 μ fd disc capacitor between lug 1 (S-2) and ground lug 10 (S-2) of tube socket V2.
- () Connect a 1/2" bare wire between lug 7 (S-1) and ground lug 12 (S-3) of tube socket V2.
- () Connect a .02 μ fd disc capacitor between lugs 3 (S-2) and 5 (S-2) of tube socket V2.
- () Connect a .02 μ fd disc capacitor between lugs 4 (NS) and 5 (NS) of terminal strip L.
- () Connect a 1-1/2" hookup wire from lug 1 of transformer L2 (S-4) to lug 4 of terminal strip L (S-5).
- () Connect a .02 μ fd disc capacitor from lug 4 of transformer L2 (S-2) to lug 5 of tube socket V1 (NS).
- () Connect a 3300 Ω (orange-orange-red) resistor from lug 5 of tube socket V1 (S-2) to lug 5 of terminal strip L (NS).
- () Connect a 10 K Ω (brown-black-orange) resistor between lugs 6 (S-4) and 5 (S-3) of terminal strip L.
- () Mount a #40-590 coil at L1. Note the position of the locating tab.
- () Connect a 1" bare wire from lug 1 of tube socket V1 (S-1) to lug 1 of coil L1 (NS).

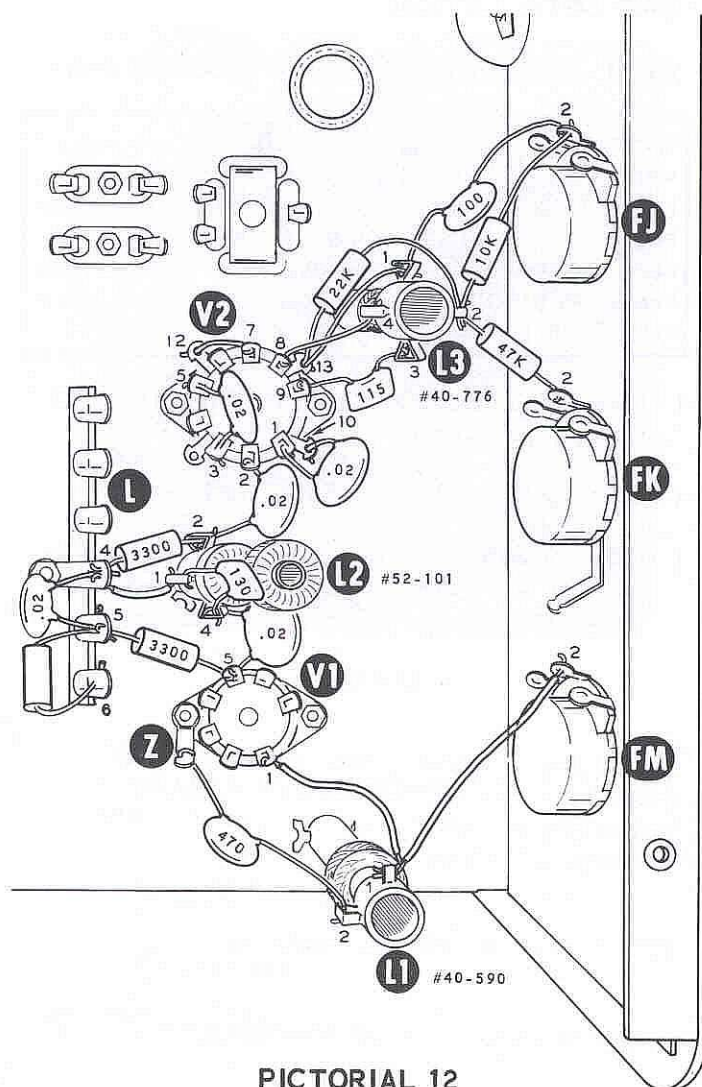

PICTORIAL 12

- () Connect a 1-3/4" hookup wire from lug 1 of coil L1 (S-2) to lug 2 of control FM (S-1).
- () Connect a 470 pf disc capacitor from lug 2 of coil L1 (S-1) to solder lug Z (S-5).

This completes the wiring of the Scanalyzer. Tip and shake the unit to dislodge any wire clippings or bits of solder that may have fallen unnoticed into the assembly. Carefully examine all connections to be sure they are properly made, and that no short circuits exist between wires or components. Then proceed to CRT Installation on Page 34. There will be some parts left over that would have been used in one of the other optional IF wiring instructions. Save these parts. You may someday want to change the wiring for use with a different IF frequency.

CRT INSTALLATION

Refer to Pictorial 13 for the following steps.

WARNING: Extreme care must be exercised when handling the CRT (cathode ray tube) due to its high vacuum. Do not strike, scratch, or subject the CRT to more than moderate pressure at any time. A fracture of the glass could result in an implosion of considerable violence capable of causing personal injury.

- () Press the cushion strip onto one of the CRT mounting clamps.
- () Carefully unpack the 3RP7 CRT.
- () Be sure the face of the CRT and the inside of the grid screen are free of smudges or fingerprints.
- () Place the CRT shield over the CRT.
- () Insert the CRT into the CRT mounting ring with the front of the CRT shield on the outside of the CRT mounting ring.
- () Orient the base of the CRT as shown in the inset on Pictorial 13.
- () Plug the CRT socket onto the CRT base.
- () Secure the rear of the CRT with the CRT mounting clamps. Make sure the rubber cushion strip is between the two clamps and the tube base. Use 6-32 x 3/8" screws and #6 lockwashers. Do not tighten the screws at this time.

PICTORIAL 13

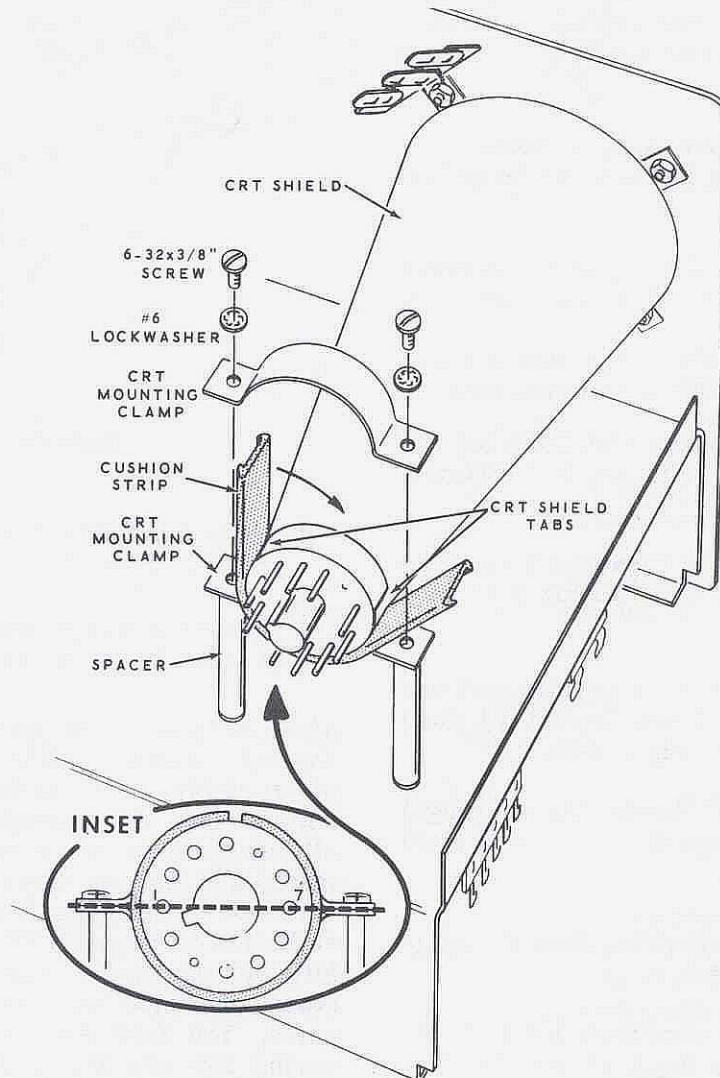

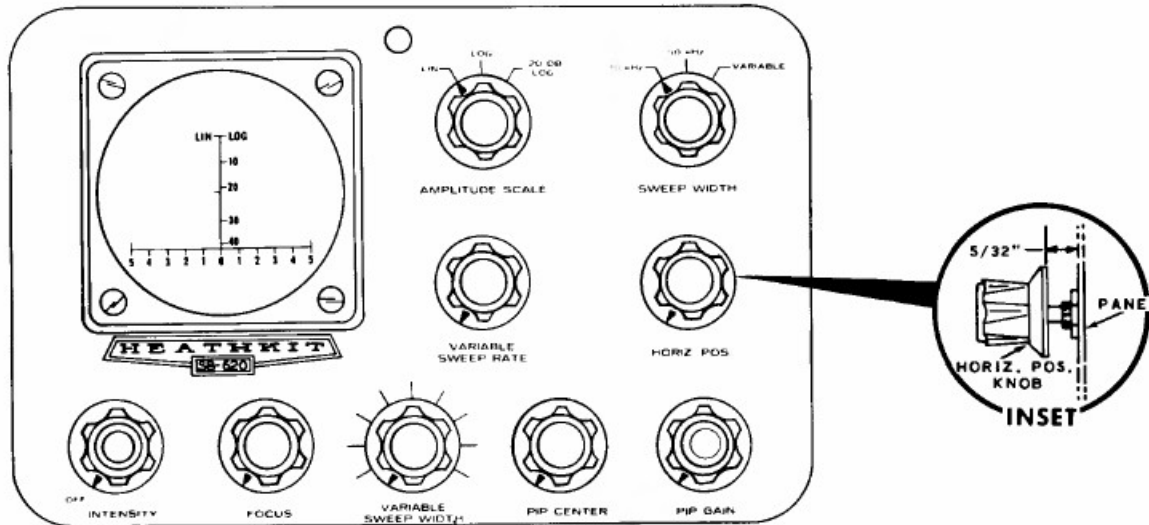

PICTORIAL 14

KNOB INSTALLATION

Refer to Pictorial 14 for the following steps.

- (✓) Turn all the control shafts fully counterclockwise.
- ⚡) Refer to Detail 14A and start an 8-32 x 1/4" setscrew in each of the nine knobs. Do not let the setscrew project into the shaft hole of the knob.

Detail 14A



- (✓) Place a knob on each of the control shafts so its pointer is positioned as shown. Tighten the setscrews.

NOTE: When mounting the HORIZ POS knob, leave a clearance of 5/32" between the panel and the skirt of the knob.

- (✓) Carefully peel away the backing paper from the blue and white identification label. Then press the label onto the chassis. Be sure to refer to the numbers on this label in any communications you have with the Heath Company about this kit.

TEST AND ADJUSTMENT

PRESET THE CONTROLS

Before applying power to the unit or making any tests, preset the controls as follows:

Front Panel Controls

- () INTENSITY - OFF (fully counterclockwise until a snap is heard).
- () FOCUS - Center of rotation.
- () VARIABLE SWEEP WIDTH - Fully clockwise.
- () PIP CENTER - Center of rotation.
- () PIP GAIN - Fully counterclockwise.
- () VARIABLE SWEEP RATE - Fully clockwise.
- () HORIZ POS - Center of rotation.
- () AMPLITUDE SCALE - LIN position.
- () SWEEP WIDTH - VARIABLE position.

Rear Apron Controls (as viewed from the rear)

- () ASTIG - Center of rotation.
- () LOG ADJ - Fully counterclockwise.
- () VERT POS - Center of rotation.
- () HORIZ WIDTH - Center of rotation.
- () HAM SCAN-SPECTRUM ANALYZER -
HAM SCAN position.
- () 20 dB ATTEN - IN position.
- () -20 dB LOG ADJ - Center of rotation.
(This control is located just above
the two slide switches on the rear
apron. The rotor of the control can
be adjusted with the alignment tool
furnished with this kit.)

RESISTANCE MEASUREMENTS

Resistance measurements were made with a vacuum tube voltmeter with one lead connected to the chassis. The resistance readings may differ as a volt-ohm-milliammeter is used.

Figure 1 enables you to identify the test points and shows the resistance to be expected at each. Due to component and meter tolerances, readings can vary up to 20%.

- () Turn the Scanalyzer bottom side up on a soft cloth. Prop up the rear of the chassis so there is no weight on the CRT socket.

Measure resistances at the following test points. Give the capacitors time to charge:

- () Terminal strip C, lug 1.
- () Terminal strip M, lug 2.
- () Terminal strip N, lug 2.
- () Capacitor S, lug 1.
- () Terminal strip R, lug 4.

NOTE: If proper resistance readings are not obtained, recheck your work and correct the condition before proceeding.

TUBE AND CRYSTAL INSTALLATION

- (✓) Install the tubes in their sockets according to the type numbers screened on the chassis.
- (✓) Refer to Figure 4 (fold-out from Page 53) and install crystals at Y1 (350,000 kHz) and Y2 (349,850 kHz).
- (✓) Install a 1/2 ampere slow-blow fuse in its holder as shown in Figure 1.

INITIAL OPERATIONAL CHECK

CAUTION: THE VOLTAGES IN THIS UNIT ARE DANGEROUS. Extreme care should be taken whenever this kit is operated or handled when not installed in its cabinet. Extremely high voltages appear at the CRT socket, the INTENSITY control terminals, and the lugs of terminal strips C, D, and E. These voltages can be **LETHAL**. **IMPORTANT:** Any time the chassis must be handled, the unit should be unplugged, and a screwdriver with an insulated handle should be used to short circuit to chassis the leads of the positive (+) and marked ends of all electrolytic and tubular capacitors.

NOTE: If at any time during the following tests the unit does not perform properly, unplug the line cord immediately and refer to the In Case of Difficulty section.

- () Plug the line cord into a 120 or 240 volt (depending on how you wired the power transformer on Page 15) 50/60 Hz, AC outlet.

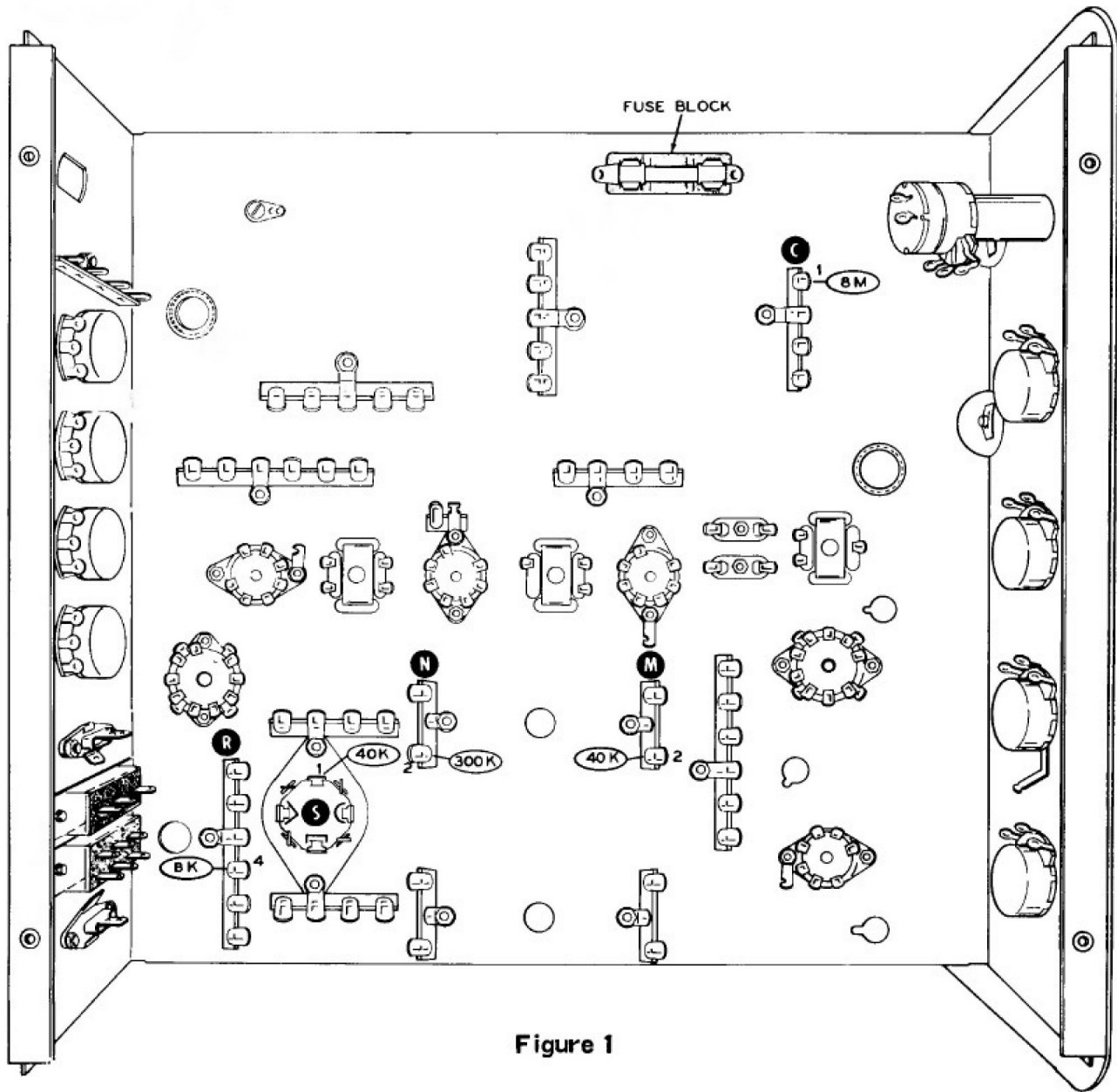

Figure 1

- () Turn the INTENSITY control to approximately 3/4 of its rotation. This will turn the unit on. The pilot lamp should come on and, in a few seconds, the tube filaments should begin to glow. The neon lamp under the chassis should begin blinking.
- () A horizontal line should appear on the face of the CRT. If no trace appears, rotate

both the HORIZ POS and VERT POS controls simultaneously until the horizontal line is centered on the CRT. NOTE: If only a spot appears, turn the VARIABLE SWEEP RATE control counterclockwise until a line does appear. If the line does not appear, refer to the first step in Alignment section and age the neon lamps.

- () Adjust the INTENSITY control until the line is clearly visible, but not overly bright.
 - () Adjust the FOCUS control for the sharpest line. It is not abnormal for this control to be in a fully clockwise position at this time.
 - () Readjust the HORIZ POS and VERT POS controls so the trace line is directly behind the horizontal line on the grid screen.
 - () Adjust the HORIZ WIDTH control until the trace extends just beyond the edges of the CRT face.
- If the line on the CRT is not perfectly horizontal, correct this condition as follows:
- () Observe the position of the line on the CRT. Rotate the tube socket as necessary to level the trace line. Do not allow the face of the CRT to slide forward and come into contact with the grid screw. After leveling the trace line, tighten the tube base clamps.

ALIGNMENT

NOTE: These alignment instructions should be followed in sequence because some adjustments must be made before other controls can operate properly. The Control Functions section of this Manual (Page 54) describes how each control should operate after alignment is completed.

- () IMPORTANT: Turn the Scanalyzer on and let it run for at least one hour. Both neon lamps have to be "aged" for this period of time when new.
- () Refer to Figure 2 and prepare the coil alignment tool by inserting the alignment tool blade (#205-254) into the small end of the nut starter.

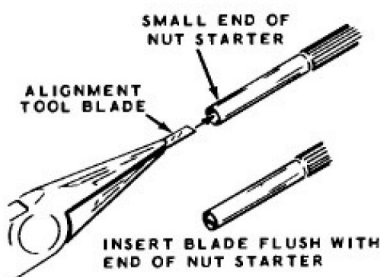

Figure 2

NOTE: There are two methods of aligning the Scanalyzer. Method 1 uses a calibrated RF signal generator with adjustable output control, while Method 2 requires that the unit be connected to a receiver. Method 1 is preferred, since it is more accurate.

METHOD 1 - ALIGNMENT WITH INSTRUMENTS

350 kHz Trap Coil Alignment

- () Be sure the LOG ADJ control is in the full counterclockwise position.
- () Connect the RF output connector of the signal generator to the IF INPUT socket of the Scanalyzer. An extra phono plug is provided for this purpose.
- () Turn on the signal generator and tune it to 350 kHz (do not modulate the test signal).
- () Set the PIP GAIN control fully clockwise.
- () Turn up the signal generator output control. Then tune the generator to first one side then the other side of 350 kHz. The CRT trace will jump abruptly when the signal generator frequency is set at exactly 350 kHz.

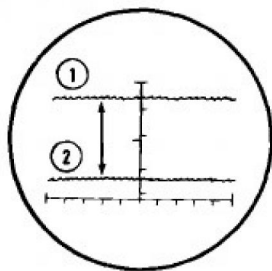

Figure 3

- () Carefully adjust the signal generator to the point where the CRT trace moves as far above the screen base line as it will go, as shown at 1 of Figure 3. Reduce the signal generator output if the CRT trace moves upward and completely off the tube screen.

Refer to Figure 4 (fold-out from Page 53), for the locations of coils and transformers.

- () Adjust the slug of coil L1 until the CRT trace moves down toward the screen base line. The correct adjustment of L1 is at the point where the CRT trace moves the closest to the screen base line. See 2 of Figure 3.

- () Now increase the signal generator output and repeat the preceding two steps to make sure the CRT trace is positioned as near as possible to the screen base line.

NOTE: If the Scanalyzer was wired for an IF frequency other than 3395 kHz, also make the following adjustment:

- () Adjust the slug of coil L2 until the CRT trace moves down toward the screen base line. Alternately adjust L1 and L2 until the CRT trace is positioned as near as possible to the screen base line.

This completes adjustment of the 350 kHz trap coil.

CHART 2

RECEIVER IF	L3 COIL NO.	APPROXIMATE COIL SETTING*
455 kHz	40-775	13 turns
1000 kHz	40-775	10 turns
1600 kHz	40-808	22-1/2 turns
1680 kHz	40-808	21 turns
2075 kHz	40-808	18 turns
2215 kHz	40-808	17 turns
2445 kHz	40-808	15 turns
3000 kHz	40-776	6 turns
3055 kHz	40-776	5-1/2 turns
3395 kHz	40-776	1/2 turn
5200 kHz	40-807	22-1/2 turns
6000 kHz	40-807	19-1/2 turns

*Coil settings are shown here as a certain number of turns from the full counterclockwise position of the coil slug.

Oscillator and Mixer Alignment

- () Set the VARIABLE SWEEP RATE control fully counterclockwise.
- () Refer to Figure 4 and turn the slug of coil L3 counterclockwise until it is just snug.
- () Refer to Chart 2, COIL SETTINGS on Page 39, and turn the slug of coil L3 clockwise the number of turns indicated for the receiver IF frequency for which the Scanalyzer was wired.
- () Tune the signal generator to the IF frequency of your receiver and set the signal level to about 1 millivolt.

NOTE: Noise pulses, harmonics, and images of the signal generator frequency can cause false pips to appear on the CRT screen. The next step will tell you how to identify the proper pip.

- () Slowly tune the signal generator on either side of the desired IF frequency while watching the CRT screen. One or more small pips may move across the screen. When the desired IF signal pip appears, it will normally fill the screen in a vertical direction. Carefully observe this pattern and remember the pip shape and size. Then reset the signal generator to the exact IF frequency of your receiver.

NOTE: The ASTIG control primarily affects the sharpness of the pip trace while the FOCUS control primarily affects the sharpness of the base line trace.

- () Adjust the ASTIG control for a sharp clear pip trace. Then adjust the FOCUS control for a sharp base line trace. Alternately adjust both of these controls for a sharp, clear, pip and base line trace.
- () Turn the slug of coil L3 until the IF signal pip is centered on the screen base line. If the top of the pip is off the CRT screen, reduce the signal generator output until the complete pip pattern is visible, as shown in Figure 5.

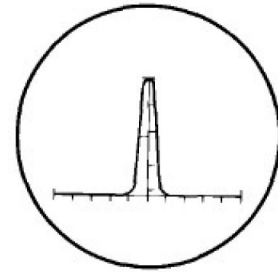

Figure 5

IMPORTANT: To make sure that oscillator coil L3 has been adjusted for the proper IF frequency, make the following checks and observations. Be sure the VARIABLE SWEEP WIDTH control is in its fully clockwise position. A "birdie" pip caused by the image frequency should be seen if you tune the signal generator exactly 700 kHz higher in frequency. This should place the "birdie" pip at the center of the screen. If the above conditions are met, oscillator coil L3 is properly set. This "birdie" pip should not be of concern in the normal application of the Scanalyzer, since 500 kHz is the maximum bandwidth required. In some units the pip may appear or disappear between the center and left-hand edge of the screen. This is a normal condition when the Variable Sweep Width control is in the fully clockwise position. It is due to the extremely wide band being swept by the sweep oscillator. This should not be of concern in the normal application of the Scanalyzer.

- () Return the signal generator to the proper IF frequency.

NOTE: It is normal, in the next step, for the amplitude of the pip to increase as the sweep width becomes narrower.

- () With the PIP CENTER control at its center of rotation, turn the VARIABLE SWEEP WIDTH control counterclockwise and observe the pip to see if it moves away from the center of the screen. If the pip moves from the center of the screen, readjust coil L3 to bring it back to the center. Keep rotating the VARIABLE SWEEP WIDTH control counterclockwise and readjusting coil L3 to keep the pip at the center of the screen.

- () Now return the VARIABLE SWEEP WIDTH control to its fully clockwise position and see if the pip moves off center. If it does, alternately rotate the VARIABLE SWEEP WIDTH control back and forth and readjust coil L3 until the pip remains stationary on the screen, changing in amplitude only. NOTE: The point where the pip stays stationary may not be at the exact center of the screen. If this occurs, move the pip to the center of the screen by adjusting the HORIZ POS control. Check the trace to be sure it extends beyond the edges of the CRT. If not, readjust the HORIZ WIDTH control.

- () Adjust both the top and bottom cores of transformer T3 for maximum pip amplitude. Only a small adjustment should be necessary from the original preset position.
- () Alternately adjust the cores of transformers T2 and T3 for the most symmetrical pip (as shown in Figure 7) while maintaining maximum pip amplitude.

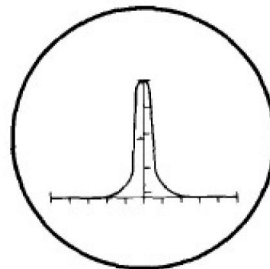

Figure 7

- () Turn the Scanalyzer OFF.

IF Alignment

- () Temporarily remove both crystals.
- () Refer to Figure 6, and connect a short jumper wire between lugs 1 and 2 of crystal socket Y2.

- () Turn the Scanalyzer OFF.
- () Remove the jumper wire from crystal socket Y2 and replace both crystals in their sockets.

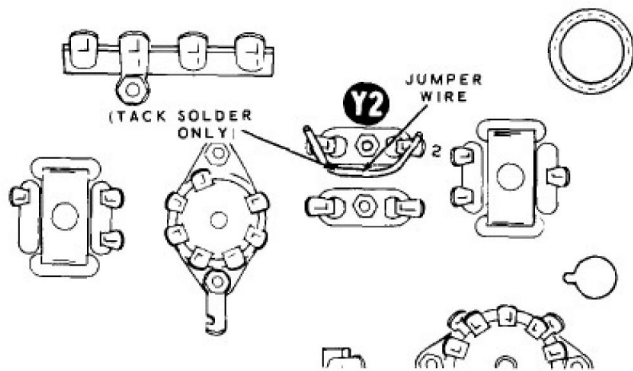

Figure 6

Logarithmic Amplitude Scale Calibration

- () Refer to Figure 8 and temporarily connect a short jumper wire from lug 1 of the HAM SCAN-SPECTRUM ANALYZER switch BH to the center lug of the IF INPUT phono socket BG.

- () Turn the Scanalyzer ON.
- () Set the VARIABLE SWEEP WIDTH and VARIABLE SWEEP RATE controls fully clockwise.
- () Adjust the signal generator output for a signal pip amplitude of about 3/4" high.
- () Adjust the core of transformer T2 for maximum pip amplitude. Readjust the signal generator output for a 3/4" high pip.

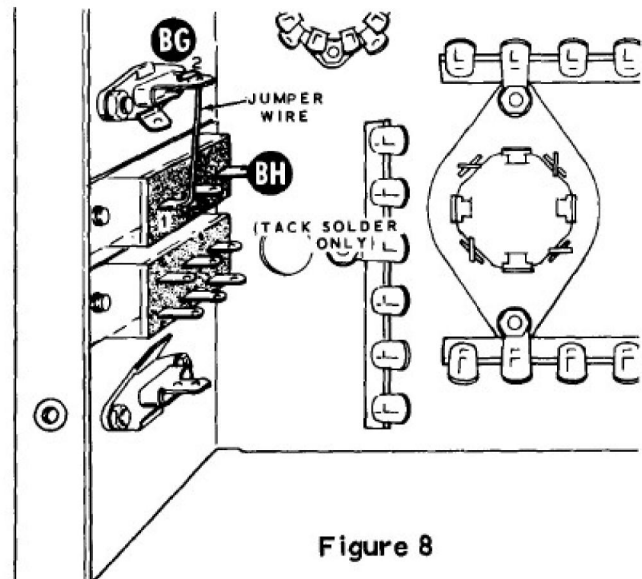
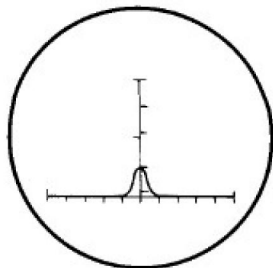

Figure 8

- () Change the signal generator RF output cable from the IF INPUT phono socket to the RF INPUT phono socket.
- () Set the 20 dB ATTEN switch at the OUT position.
- () Turn the Scanalyzer ON.
- () Set the VARIABLE SWEEP RATE control fully counterclockwise.
- () Set the AMPLITUDE SCALE switch at the LOG position.
- () Check to be sure the trace coincides with the base line. Readjust the VERT POS control if necessary.
- () Adjust the signal generator output for a pip amplitude of 0 dB. (This is at the top of the vertical scale.) Make sure that the top of the pip is even with the cross line between LIN and LOG.
- () Turn the LOG ADJ control clockwise until the top of the pip is even with the 10 dB mark.
- () Adjust the signal generator output for a pip amplitude of 0 dB with the AMPLITUDE SCALE switch set at the LOG position.
- () Now set the AMPLITUDE SCALE switch at the -20 dB LOG position.
- () Adjust the -20 dB LOG ADJ control (located above the rear apron of the unit) until the top of the pip is even with the 20 dB mark on the screen.
- () Readjust the signal generator output for maximum (but not higher than 0 dB) pip amplitude.
- () Now set the AMPLITUDE SCALE switch back at the LOG position.
- () Compare the pip on the CRT screen with the pip shown in Figure 10. If there is any ringing or flyback on either side of the pip, as shown in Figure 11, adjust the core of transformer T1 to minimize it. Only a slight adjustment should be necessary from the factory preset position.

Figure 9



- () Set the 20 dB ATTEN switch at the IN position and observe the pip. The top of the pip should be approximately even with the 30 dB mark as shown in Figure 9. This adjustment calibrates the logarithmic amplitude scale.
- () Turn the Scanalyzer OFF.
- () Remove the jumper wire that was connected between the HAM SCAN-SPECTRUM ANALYZER switch and the IF INPUT phono socket.
- () Change the signal generator RF output cable from the RF INPUT phono socket to the IF INPUT phono socket.
- () Turn the Scanalyzer back ON.

After the above adjustment, if there appears to be a considerable amount of ripple on both sides of the pip, or there are side pips such as shown in Figure 12 (with an unmodulated input signal), a possible cause is the neon lamp voltage regulator (NE-83-A). Refer to Pictorial 5, fold-out from Page 21, and interchange the two leads from lamp FC.

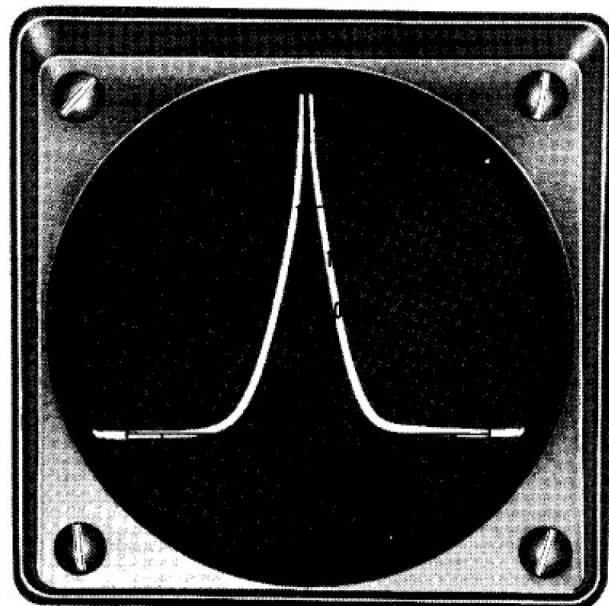

Figure 10

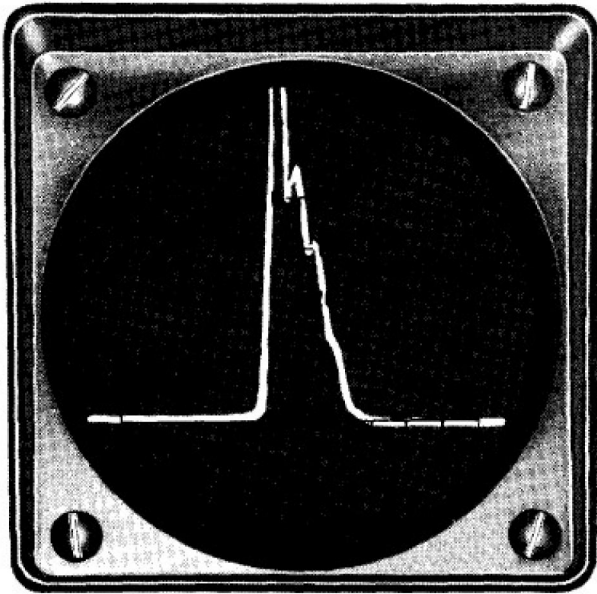

Figure 11

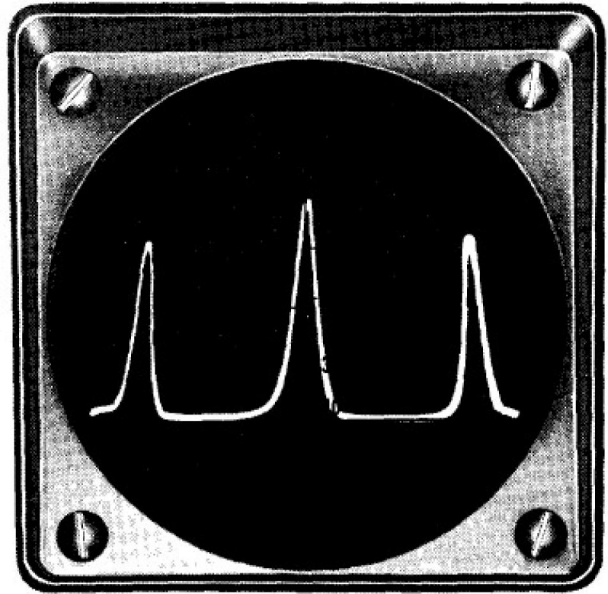

Figure 12

Sweep Width Calibration

- () Connect a high quality audio generator, such as the Heathkit IG-72 or AG-9, etc., to the Modulation input of the RF signal generator. NOTE: If you do not have a high quality audio generator, proceed directly to the next section, Connection To Receiver, and connect your Scanalyzer to your receiver as directed. Then turn back to Page 48 and perform the Sweep Width Calibration that is described under Alignment Method 2.
- () Set the audio generator for a frequency of 50 kHz and adjust the audio output for 70% to 100% modulation of the RF signal.
- () Adjust the signal generator output for a pip amplitude of 0 dB. Observe that there are three pips on the CRT screen. The center pip is the RF carrier signal and the two side pips are the modulation products of the 50 kHz audio signal.
- () Adjust the VARIABLE SWEEP WIDTH control in a counterclockwise direction and observe that the two side tone pips will move towards the edges of the screen. Adjust this control until both side tone pips are over the 5 marks on the base line as shown in Figure 12. Use the PIP CENTER control to keep the carrier signal at the center of the screen.
- () Observe where the pointer is set on the VARIABLE SWEEP WIDTH control. Make a note of this setting for future reference; this is the 100 kHz bandwidth setting.
- () Set the audio generator for a frequency of 25 kHz.
- () Place the SWEEP WIDTH control at the 50 kHz position.
- () Repeat the procedure above, adjusting the VARIABLE SWEEP WIDTH control until the two side tone pips are over the 5 marks on the base line of the CRT screen.
- () Again make note of the pointer setting for future reference; this is the 50 kHz bandwidth setting.
- () Set the audio generator for a frequency of 5 kHz.
- () Place the SWEEP WIDTH control at the 10 kHz position.
- () Repeat the above procedure again and note the pointer setting for the 10 kHz bandwidth setting.

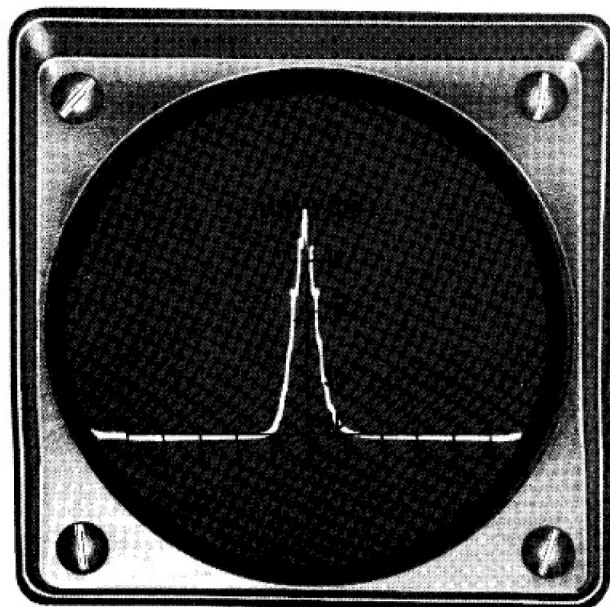

Figure 13

NOTE: Because of the narrow sweep width and slow sweep rate with the SWEEP WIDTH control at the 10 kHz position, the pip or pips may be somewhat wider than they were before. Also, depending on the signal source, there may be some hum causing the pip to have a ripple effect (see Figure 13).

This completes Scanalyzer Alignment Method 1. Turn to Connection To Receiver on Page 50.

METHOD 2 - ALIGNMENT WITHOUT INSTRUMENTS

NOTE: This method of aligning the Scanalyzer is recommended only if no test instruments are available. To perform these adjustments, you will need either a receiver with a crystal calibrator or a receiver and a transmitter that has a spotting signal.

Refer to Figure 4 (fold-out from Page 53) for the locations of coils and transformers.

350 kHz Trap Coil Alignment

- () Be sure the LOG ADJ control is in the full counterclockwise position.
- () Cut two 3" hookup wires. Remove 1/4" of insulation from one end of each wire.

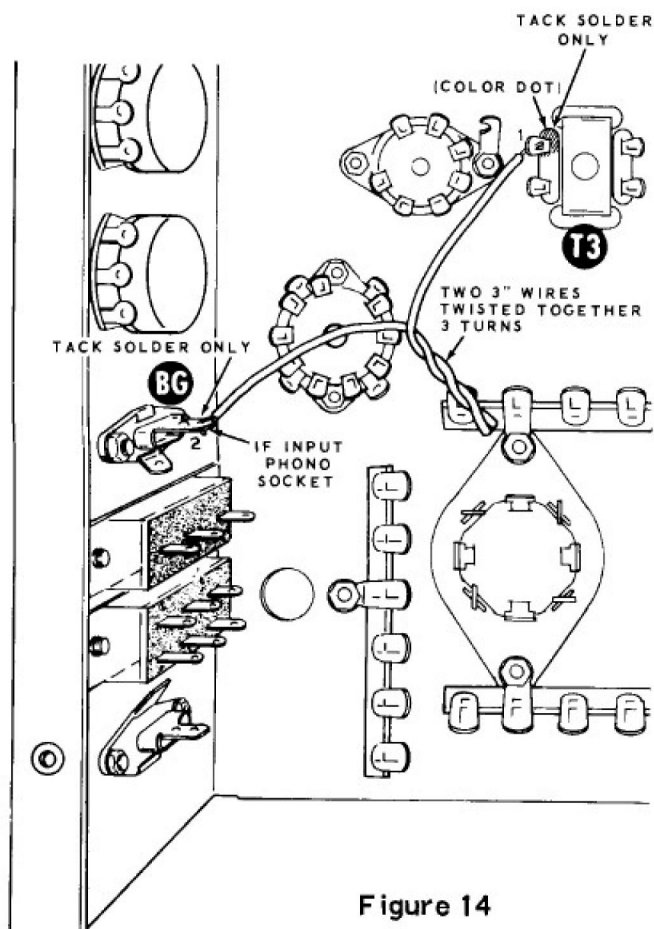

Figure 14

Refer to Figure 14 for the following three steps:

- () Solder the stripped end of one wire to lug 1 of IF transformer T3.
- () Solder the stripped end of the other wire to the center lug of the IF INPUT phono socket BG.
- () Twist the free ends of these wires together for about three turns.
- () Turn on the Scanalyzer and let it warm up for ten minutes.

NOTE: In this adjustment, a 350 kHz signal will be generated within the Scanalyzer due to a feedback path through the twisted wires and the high-gain IF strip. Oscillation will occur as the PIP

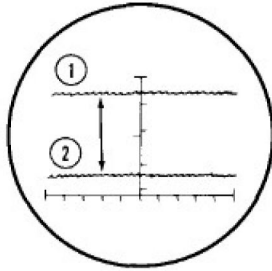

Figure 15

GAIN control is advanced clockwise. The CRT trace will abruptly deflect vertically. See Figure 15.

- () Set the PIP GAIN control fully clockwise.
- () Either twist more turns or untwist turns until the trace is at position 1 as shown in Figure 15. If the trace jumps completely off the screen, it may be necessary to untwist the wires completely and just have them near each other.
- () Adjust the slug of coil L1 until the CRT trace moves down toward the screen base line. The correct adjustment of L1 is at the point where the CRT trace moves the closest to the screen base line.

NOTE: If the Scanalyzer was wired for an IF frequency other than 3395 kHz, also make the following adjustment.

- () Adjust the slug of coil L2 until the CRT trace moves down toward the screen base line. Alternately adjust L1 and L2 until the CRT trace is positioned as near as possible to the screen base line.
- () Adjust IF transformer T2 for maximum deflection in the upward direction, but keep the trace on the screen of the CRT by turning the PIP GAIN control counterclockwise.
- () Turn the Scanalyzer OFF and remove the two twisted wires.

This completes adjustment of the 350 kHz trap coil.

Oscillator and Mixer Alignment

- () Connect the Scanalyzer to the receiver with which it will be used as directed in the Connection To Receiver section on Page 50.
- () Turn the slug of coil L3 counterclockwise until it is just snug.
- () Refer to Chart 2 on Page 39 and turn the slug of coil L3 clockwise the number of turns indicated for the IF frequency for which the Scanalyzer was wired.
- () Set the VARIABLE SWEEP RATE control fully counterclockwise.
- () Be sure the cable from the receiver is plugged into the IF INPUT phono socket on the rear apron.
- () Disconnect any antenna from the receiver. If there is any signal feedthrough from the receiver antenna input terminal, it may be necessary to terminate the receiver's antenna input with a resistor matching the receiver's input impedance.
- () Turn ON the Scanalyzer and the receiver (and the transmitter with the spotting signal) if one is being used.
- () Tune in on the receiver, for maximum volume or S-meter reading, either the receiver's own calibrator signal or the spotting signal from a transmitter.

NOTE: When the Scanalyzer is connected to a transceiver without a crystal calibrator, use the "tune" position of the transceiver, with minimum output, for a signal source. This signal source can be used for all parts of this alignment procedure except the Sweep Width Calibration, where another signal source will be needed.

- () Turn the PIP GAIN control fully clockwise.

IMPORTANT: In addition to the correct pip, which is from the received calibration or spotting signal, you may also see some false pips in the following step (these false pips are usually caused by harmonics, images, or noise pulses). Be sure you are using the correct pip before making the following adjustments. Refer to the following paragraphs to identify the correct pip.

Turn the signal source off. The correct pip (and any other signals that are coming from your signal source) will disappear from the screen. Turn the signal source on again.

Turn the receiver 10 or 20 kHz to one side of the tuned signal's center frequency. The amplitude of the correct pip, the one that corresponds to the signal being heard, should increase slightly in amplitude.

If a 100 kHz crystal calibrator is used for the signal source, and depending on the front end selectivity of the receiver being used, there could be as many as five pips of the same signal appearing at the same time, spaced approximately 100 kHz from each other on the screen. Peak the calibrator signal on the S-meter of the receiver; then detune slightly. Use the highest pip near the center of the screen.

- () Turn the slug of coil L3 until the correct pip is centered on the screen base line. If the top of the pip is off the screen at the top of the CRT, reduce the PIP GAIN control setting until the complete pip pattern is visible as shown in Figure 16.

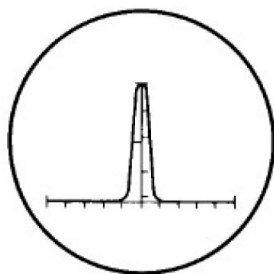

Figure 16

NOTE: The ASTIG control primarily affects the sharpness of the pip trace while the FOCUS control primarily affects the sharpness of the base line trace.

- () Adjust the ASTIG control for a sharp, clear, pip trace. Then adjust the FOCUS control for a sharp base line trace. Alternately adjust both of these controls for a sharp, clear, pip and base line trace.

NOTE: It is normal, in the next step, for the amplitude of the pip to increase as the sweep width becomes narrower.

- () With the PIP CENTER control set at center of rotation, turn the VARIABLE SWEEP WIDTH control counterclockwise and observe the pip to see if it moves away from the center of the screen. If the pip moves from the center of the screen, readjust coil L3 to bring it back to the center. Keep rotating the VARIABLE SWEEP WIDTH control counterclockwise and readjusting coil L3 to keep the pip at the center of the screen.
- () Now return the VARIABLE SWEEP WIDTH control to its fully clockwise position and see if the pip moves off center. If it does, alternately rotate the VARIABLE SWEEP WIDTH control back and forth and readjust coil L3 until the pip remains stationary on the screen, changing in amplitude only. **NOTE:** The point where the pip stays stationary may not be at the exact center of the screen. If this occurs, move the pip to the center of the screen by adjusting the HORIZ POS control. Check the horizontal trace line to be sure it extends beyond the edges of the CRT. If not, readjust the HORIZ WIDTH control.

Turn the Scanalyzer OFF.

IF Alignment

- () Temporarily remove both crystals.
- () Connect a short jumper wire between lugs 1 and 2 of crystal socket Y2 as shown in Figure 17.

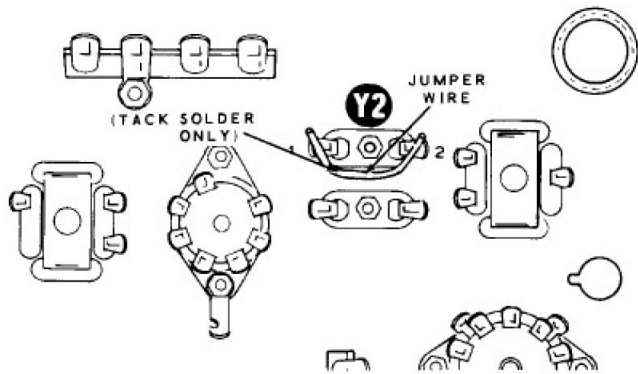

Figure 17

- () Turn the Scanalyzer ON.
- () Set the VARIABLE SWEEP WIDTH control fully counterclockwise and the VARIABLE SWEEP RATE control fully clockwise.
- () Set the PIP GAIN control for a signal pip amplitude of about 3/4".
- () Adjust the core of transformer T2 for maximum pip amplitude.
- () Adjust both cores of transformer T3 for maximum pip amplitude. Only a slight adjustment should be necessary from the original preset position.
- () Now, alternately adjust the cores of transformers T2 and T3 for the most symmetrical pip (as shown in Figure 18) while maintaining maximum pip amplitude.

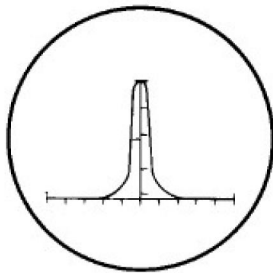

Figure 18

- () Turn the Scanalyzer OFF.
- () Remove the jumper wire from crystal socket Y2 and replace both crystals in their sockets.

Logarithmic Amplitude Scale Calibration

- () Refer to Figure 19 and temporarily connect a short jumper wire from lug 1 of the HAM SCAN-SPECTRUM ANALYZER slide switch (BH) to the center lug of the IF INPUT phono socket (BG).

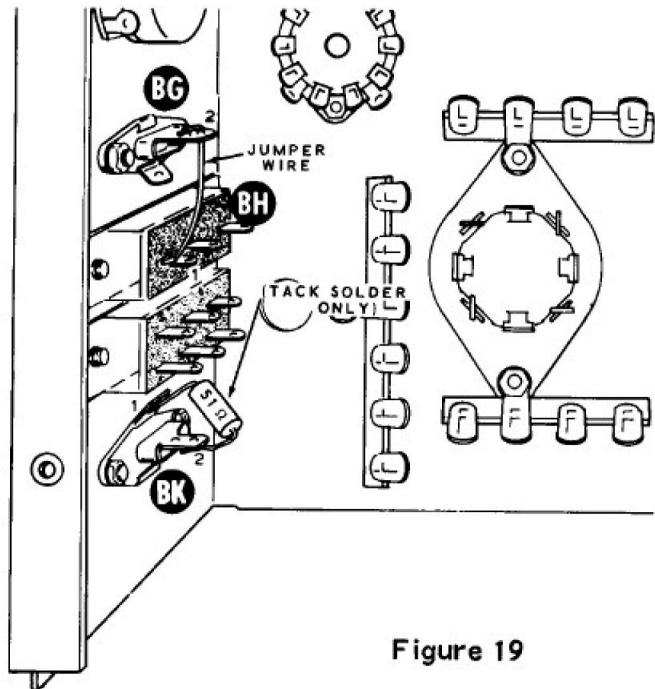

Figure 19

- () Again refer to Figure 19 and temporarily connect one lead of a 51 Ω resistor from the center lug of the RF INPUT phono socket to its ground lug (BK).
- () Change the receiver IF cable from the IF INPUT phono socket to the RF INPUT phono socket.
- () Set the 20 dB ATTEN switch at the OUT position.
- () Turn the Scanalyzer ON.
- () Set the VARIABLE SWEEP RATE control at its fully counterclockwise position.
- () Set the AMPLITUDE SCALE switch to the LOG position.
- () Check to be sure the trace coincides with the base line. Readjust the VERT POS control if necessary.

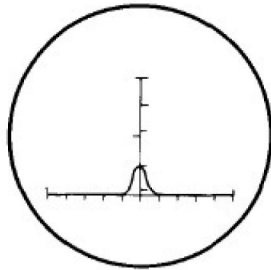

Figure 20

- () Adjust the PIP GAIN control for an amplitude of 0 dB. (This is at the top of the vertical scale.) Make sure that the top of the pip is even with the cross line between LIN and LOG.
- () Turn the LOG ADJ control in a clockwise direction until the top of the pip is even with the 10 dB mark.
- () Set the 20 dB ATTEN switch at the IN position and observe the pip. The top of the pip should be approximately even with the 30 dB mark as shown in Figure 20. This adjustment calibrates the logarithmic amplitude scale.
- () Turn the Scanalyzer OFF.
- () Remove both the jumper wire and 51 Ω resistor.
- () Relocate the receiver IF cable back to the IF INPUT phono socket.
- () Turn the Scanalyzer back ON.
- () Adjust the PIP GAIN control for a pip amplitude of 0 dB with the AMPLITUDE SCALE switch set at the LOG position.
- () Now set the AMPLITUDE SCALE switch at the -20 dB LOG position.
- () Adjust the -20 dB LOG ADJ control, located above the rear apron of the unit, until the top of the pip is even with the 20 dB mark on the screen.

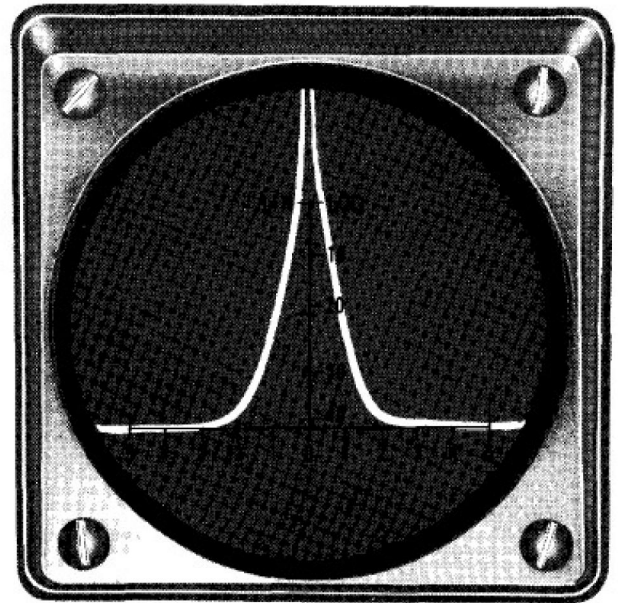

Figure 21

- () Readjust the PIP GAIN control for maximum (but not higher than 0 dB) pip amplitude.
- () Now set the AMPLITUDE SCALE switch back at the LOG position.
- () Compare the pip on the CRT screen with the pip shown in Figure 21. If there is any ringing or flyback on either side of the pip, as shown in Figure 22, adjust the core of transformer T1 to minimize it. Only a slight adjustment should be necessary from the factory preset position.

After the above adjustment, if there appears to be a considerable amount of ripple on both sides of the pip, or there are side pips such as shown in Figure 22 (with an unmodulated input signal), a possible cause is the neon lamp voltage regulator (NE-83-A). Refer to Pictorial 5, fold-out from Page 21, and interchange the leads from lamp FC.

Sweep Width Calibration

- () Adjust the PIP GAIN control for an amplitude of 0 dB.
- () Set the VARIABLE SWEEP WIDTH control fully clockwise.

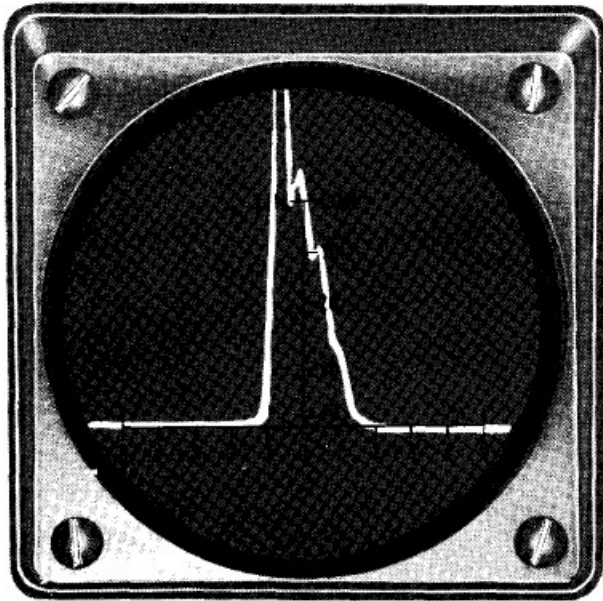

Figure 22

- () Set the receiver exactly 50 kHz higher in frequency.
- () Turn the VARIABLE SWEEP WIDTH control counterclockwise until the pip is over the 5 mark on the base line.
- () Set the receiver back to the center frequency and, if necessary, use the PIP CENTER control to center the pip on the screen.
- () Set the receiver exactly 50 kHz lower in frequency. The pip should be over the opposite 5 mark on the base line. It may be necessary to readjust both the VARIABLE SWEEP WIDTH and PIP CENTER controls to get both the pips to fall over these marks.
- () Observe where the pointer is set on the VARIABLE SWEEP WIDTH control and make a note of this setting for future reference. This is the 100 kHz bandwidth setting.
- () Place the SWEEP WIDTH control at the 50 kHz position.
- () Set the receiver exactly 25 kHz higher in frequency.

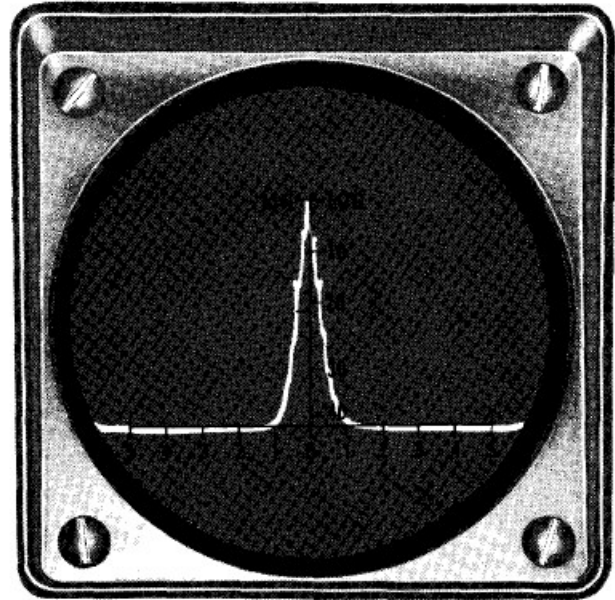

Figure 23

- () Repeat the procedure as above, adjusting the VARIABLE SWEEP WIDTH control until the pip is over the 5 mark on the base line. Set the receiver exactly 25 kHz lower than the center frequency. The pip should be over the opposite 5 mark on the base line.
- () Again, make a note of the pointer setting of the VARIABLE SWEEP WIDTH control for future reference. This will be the 50 kHz bandwidth setting.
- () Place the SWEEP WIDTH control at the 10 kHz position.
- () Repeat the entire procedure, except set the receiver exactly 5 kHz on either side of center frequency.
- () Again note the pointer setting of the VARIABLE SWEEP WIDTH control. This will be the 10 kHz bandwidth setting.

NOTE: Because of the narrow sweep width and slow sweep rate with the SWEEP WIDTH control at the 10 kHz position, the pip may appear wider than it did before. Also, depending on the signal source, there may be some hum causing the pip to have a ripple effect (see Figure 23).

This completes Scanalyzer Alignment Method 2. Refer to Final Assembly on Page 53.

CONNECTION TO RECEIVER

The Scanalyzer is now ready to connect to your receiver. In most cases, the connection will be made to the plate lug of the mixer tube socket. Refer to the Receiver IF Chart, Chart 3, to find the proper connecting point. If your receiver is not listed in the chart, use your receiver's schematic to find the plate lug of the mixer tube socket.

If there is more than one mixer tube in your receiver, the connection should be made to the plate of the mixer tube into which the receiver variable oscillator signal is injected. **NOTE:** The connection must be made to the mixer plate ahead of the IF transformer, or crystal or mechanical filter, that is connected to the mixer plate. If the receiver signal passed through these selectivity-determining components before it was coupled to the Scanalyzer, the frequency response would be too narrow.

- () Refer to Chart 3 and determine the value of coupling capacitor C_c that must be used for your receiver. The input signal will be coupled through this capacitor to the IF INPUT socket of the Scanalyzer. If your receiver is not listed, use the minimum value of coupling capacitor which produces a normal pip pattern on the Scanalyzer.
- () Refer to the "Make Connection To" column in Chart 3 and determine the proper connecting point for capacitor C_c in your receiver (plate lug of mixer tube socket). Then locate this point on the Schematic (and appropriate pictorial, if available) for your receiver.
- () Remove your receiver from its cabinet and locate the connecting point on the chassis.
- () Determine how you will route the coaxial cable from the connecting point in your receiver to the IF INPUT socket of the Scanalyzer. Some receivers have an unused phono jack or terminal strip lug that can be used as a signal output terminal. If your receiver has no such unused connector, the coaxial cable will have to be routed to the Scanalyzer through a hole in the receiver chassis.
- () Cut the coaxial cable to the proper length to reach either the unused connector or the IF INPUT socket of the Scanalyzer.

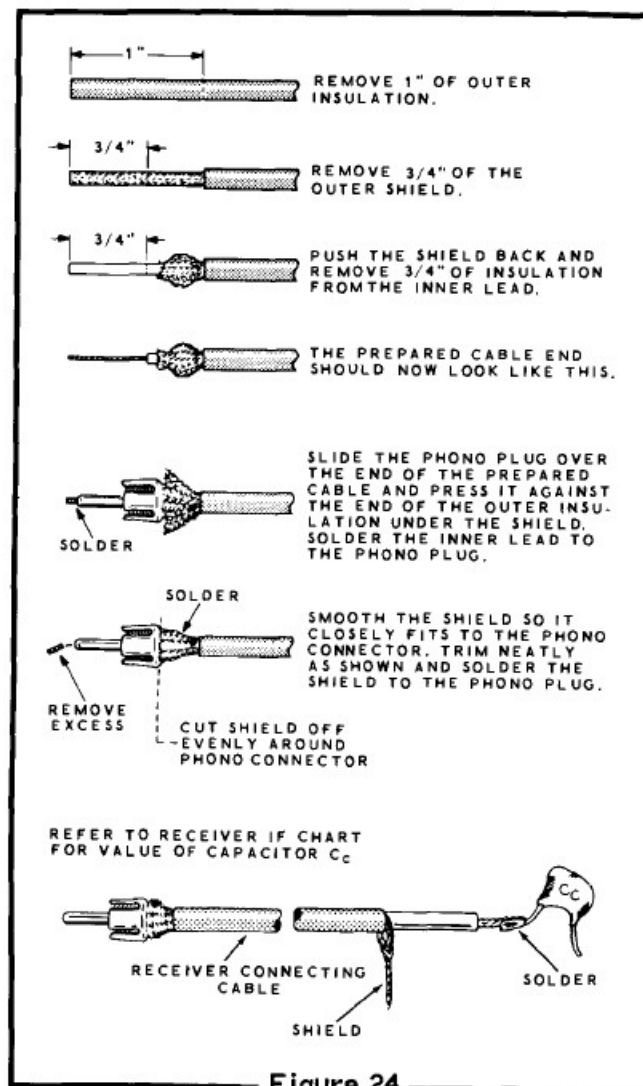

Figure 24

Prepare the coaxial cable as directed in only one of the next two steps. Use the step that applies to your installation.

- () Refer to Figure 24 and prepare two coaxial cables, one with capacitor C_c attached to reach from the connecting point to the unused connector in your receiver, and the other to connect between the unused connector and the IF INPUT socket of the Scanalyzer.
- () Prepare a coaxial cable as shown in Figure 24 with capacitor C_c at one end and a phono plug at the other end.

**CHART 3
RECEIVER INTERMEDIATE FREQUENCIES**

MAKE	MODEL	IF (kHz)	MAKE CONNECTION TO	C _c COUPLING CAPACITOR pf
HEATH	GC-1A	455	Collector of X2 (mixer)	12
	GR-54	1682	Pin 6 of V2 (6EA8)	7.5
	GR-91	455	Pin 5 of V1 (12BE6)	12
	HR-10	1681	Pin 6 of V2A (6EA8)	12
	HR-20	3000	Pin 6 of V2A (6EA8)	7.5
	MR-1	3000	Pin 6 of 6EA8 (mixer)	7.5
	RX-1	1681	Pin 5 of 6CS6 (1st mixer)	12
	SB-100	3395	Pin 6 of V12A (6EA8)	7.5
	SB-101	3395	Pin 6 of V12 (6EA8)	7.5
	SB-110,110-A	3395	Lug 1 of Y5 (crystal filter)	12
	SB-300	3395	Pin 5 of V3 (6AU6)	7.5
SB-301	3395	Pin 5 of V3 (6AU6)	7.5	
COLLINS	75S1, S2	455	Pin 6 of V3A (6U8A)	12
	75S3, S3B	455	Pin 6 of V4A	12
	75A Series	455	Pin 9 of V5 (6BA7)	12
DRAKE	2A, 2B	455	Pin 5 of V3 (6BE6)	12
	R4, R4-A	5645	Pin 5 of V2 (6HS6)	7.5
EICO	753	5200	Pin 5 of V17 (6BE6)	7.5
HALLI-CRAFTERS	SX-100	1650	Pin 5 of V2 (6AU6)	12
	SX-101A	1650	Pin 5 of V2 (6BY6)	12
	SX-117	1650	Pin 5 of 2nd mixer (6BE6)	12
	SR-150	1650	Pin 6 of V17 (6EA8)	7.5
NATIONAL	NC-200	5200	Pin 5 of V2 (12BE6)	7.5
RME	6900	2195	Pin 6 of V2 (6U8)	7.5
SWAN	350	5174	Pin 5 of V7 (12BE6)	7.5

THE CONNECTING CABLE MUST BE CONNECTED TO THE PLATE OF THE MIXER TUBE JUST PRECEDING THE FIRST IF AMPLIFIER OF THE RECEIVER.

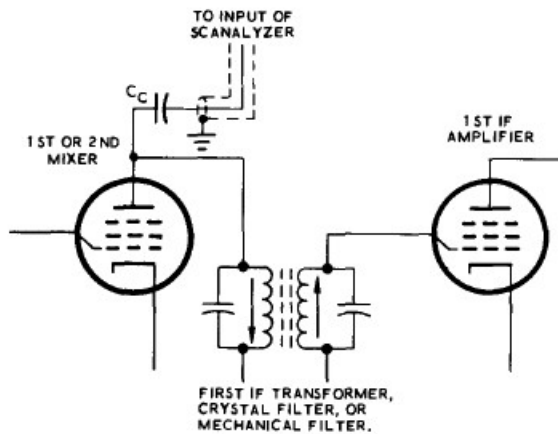

Figure 25

NOTE: It may be helpful to refer to Figure 25 for the next step.

- () Connect the free lead of capacitor C_c to the connecting point for your receiver that was identified in the previous steps. Solder the connection. Use sleeving or tape on the capacitor leads if there is any chance of them shorting to another wire or lug, or the chassis.
- () Connect the shield lead at the end of the coaxial cable near capacitor C_c to the closest ground point in your receiver.
- () If you are using an unused phono jack or terminal strip lug in your receiver, connect the other end of the coaxial cable to this connector.
- () Connect the coaxial cable from the receiver to the IF INPUT socket of the Scanalyzer and operate the units before reinstalling the receiver in its cabinet. If the connection has been made to the proper point, tuning the receiver across the band will move the signal pips across the CRT screen.

NOTE: If your receiver uses an IF transformer in the mixer plate circuit, be sure to readjust the primary coil slug of this transformer for maximum signal output after the Scanalyzer input cable is connected.

With the Scanalyzer connected to the same receivers, you may hear a series of "clicks" in the speaker output. This is due to the sweep oscillator signal of the Scanalyzer getting back into the receiver. This will usually occur only with the Sweep Width control in its fully clockwise position, and normally can be eliminated by turning the control slightly counterclockwise. If it still persists, adding a small value of resistance (i.e. 1000 Ω) in series with coupling capacitor C_c will help reduce the effect.

- () Reinstall the receiver in its cabinet, if necessary removing the connecting cable from the Scanalyzer input jack.
- () Reconnect the cable from your receiver to the Scanalyzer.

This completes the connecting procedure.

NOTE: Disregard the next paragraph and proceed to Final Assembly if you used Method 2 - Alignment Without Instruments.

If you used Alignment Method 1 and, for lack of the proper AF signal generator, did not complete the Sweep Width Calibration (Page 38), refer back now to Page 48 and complete the Sweep Width Calibration steps for Alignment Method 2. Then proceed to Final Assembly.

FINAL ASSEMBLY

Refer to Figure 26 for the following steps.

Two sizes of plastic feet and four rubber feet are supplied so the Scanalyzer can be set level, or tilted upward or downward. Figure 26 shows the feet and hardware used for a typical installation, and to provide a tilt to match other Heathkit SB series equipment.

- () Choose the type of feet needed to support the Scanalyzer at the angle you prefer.

- () Slide the unit into the cabinet.

- () Fasten the Scanalyzer in the cabinet with the foot mounting screws and appropriate feet (and washers if used). Use 6-32 x 3/4" screws and #6 flat washers with the rubber feet, and 6-32 x 3/4" screws with the short plastic feet. Use 6-32 x 1-1/2" screws with the long plastic feet.

Save the two extra screws and any feet or washers not used. You may want to change the tilt later.

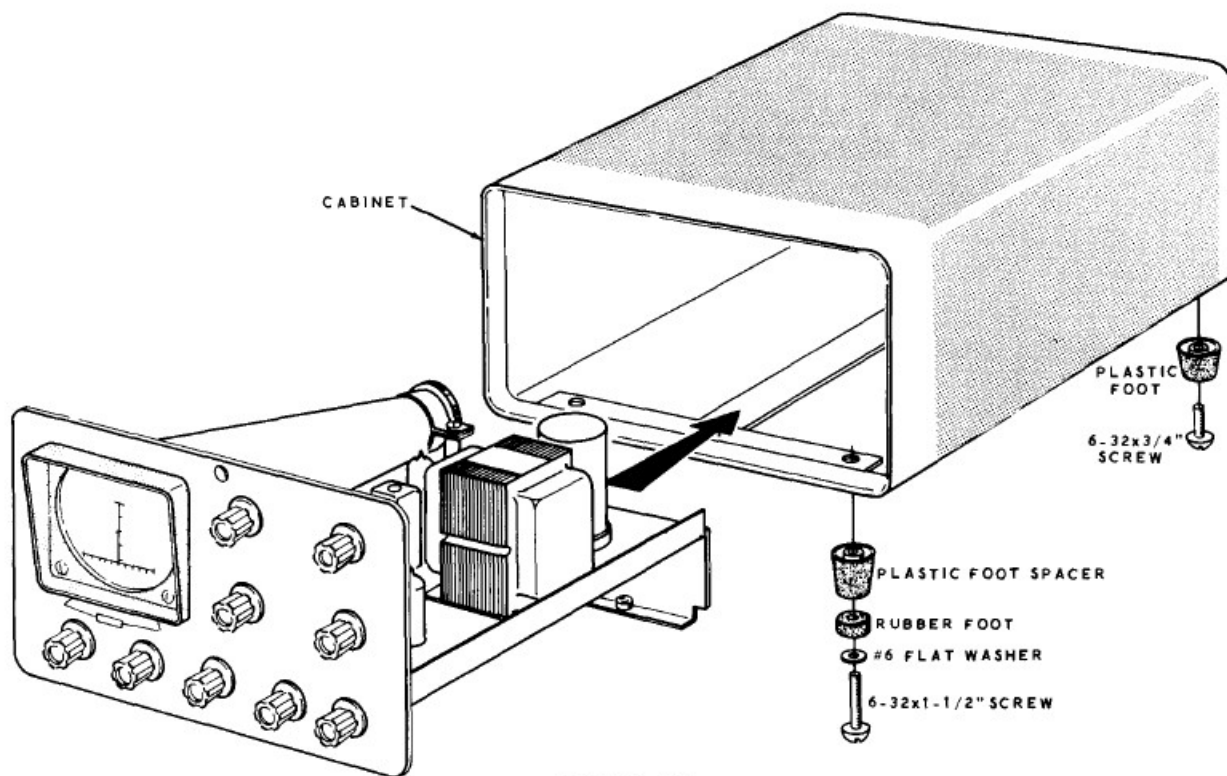

Figure 26

OPERATION

Read this section carefully so you will be aware of the several ways in which this versatile instrument can be used. Figures 40-1 through 40-8 (fold-out from Page 54) and Figures 40-9 through 40-13 (fold-out from Page 63) show many of the actual traces which you will see on the face of the CRT. Refer to these illustrations as you read this section of the Manual.

CONTROL FUNCTIONS

The following paragraphs describe what each control does. Names of controls, connectors, and switches are shown as they are lettered on the instrument. If an abbreviated name is lettered on the instrument, the complete name is given in parentheses after the abbreviation. Refer to Figure 27.

Front Panel Controls

INTENSITY: Turns the unit ON or OFF. Adjusts the brilliance of the screen presentation.

FOCUS: Adjusts the sharpness of the base line trace.

VARIABLE SWEEP WIDTH: Used as a variable adjustment for the bandwidth of the frequency spectrum shown on the screen. With the control fully clockwise, the maximum spectrum width is seen. As the control is turned counterclockwise, the bandwidth becomes narrower and the part of the spectrum being viewed is expanded across the screen. This control is normally used with the SWEEP WIDTH switch at the VARIABLE position, but it is also used to calibrate the

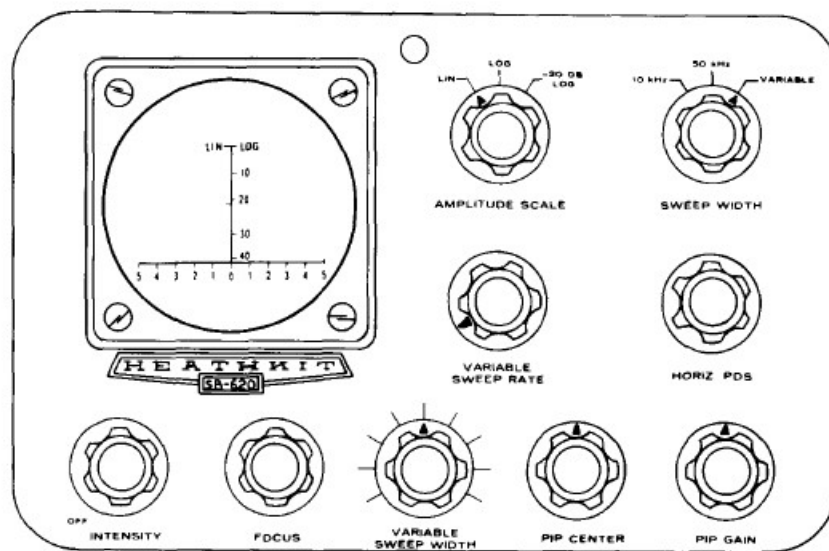

NOTE: CONTROLS ARE SHOWN IN THEIR NORMAL POSITION FOR HAM-SCAN USE. IF NO KNOB POINTERS (OR SCREWDRIVER SLOTS FOR REAR APRON CONTROLS) ARE ILLUSTRATED IT INDICATES THAT THE CONTROL SHOULD BE ADJUSTED TO PRODUCE THE DESIRED EFFECT.

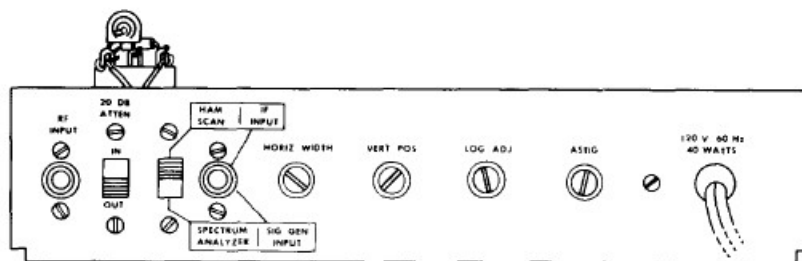

Figure 27

screen base line when the SWEEP WIDTH switch is at either the 50 kHz or 10 kHz preset positions.

PIP CENTER: Normally used to place the signal pip at the center of the CRT screen. When a bandwidth of 100 kHz or less is viewed, the signal pip can also be placed at either edge of the CRT screen. This allows a band of frequencies to be viewed that is either higher or lower than the center mean frequency of the local sweep oscillator.

PIP GAIN: Adjusts the pip height on the CRT screen. Maximum gain is obtained at the full clockwise position.

VARIABLE SWEEP RATE: Provides continuously adjustable scanning rates between 5 Hz to 15 Hz. This control is normally used when the SWEEP WIDTH switch is at the VARIABLE position, although it has some vernier effect in the 10 kHz or 50 kHz positions. Clockwise rotation increases the sweep rate.

HORIZ POS (Horizontal Position): Adjusts the position of the base line trace along the horizontal axis. This control allows the operator to adjust the signal pip to the center of the CRT screen if small inaccuracies occur between the PIP CENTER control and the local sweep oscillator.

Pushing in on the HORIZ POS control actuates a momentary contact switch which temporarily speeds up the sweep rate when the SWEEP WIDTH switch is at either the 10 kHz or 50 kHz positions. This makes it easier to center the signal pip on the CRT screen at the slower sweep rates.

AMPLITUDE SCALE: Selects either a linear or logarithmic amplitude presentation. In the LOG position, signals whose amplitude differs by as much as 40 dB (100:1) in amplitude may be viewed simultaneously on the screen using the calibration marks on the right side of the vertical calibrated line. In the LIN (Linear) position, signals are displayed with their amplitudes displaced linearly on the screen.

A third position of this switch, -20 dB LOG, causes the IF system to attenuate the signal 20 dB. This permits you to study signals over a dynamic range of 60 dB (1000:1). Under these conditions, only the lower 40 dB portion is displayed on the CRT screen. (See Distortion Measurement, Page 62.)

SWEEP WIDTH: Selects fixed sweep widths of 10 kHz and 50 kHz or a VARIABLE sweep width. In the VARIABLE position, the operator can adjust the sweep width by using the VARIABLE SWEEP WIDTH control. In the preset positions, the SWEEP WIDTH switch automatically sets the IF gain and selects the proper filtering for the detected signal pip.

Rear Apron Controls

-20 dB LOG ADJ (-20 dB Logarithmic Adjustment): Adjusted for the proper bias on V3 when the AMPLITUDE SCALE switch is at the -20 dB LOG position. Once the bias is adjusted for the proper 20 dB of attenuation in this stage, it need not be readjusted unless tube V3 is changed.

RF INPUT: A test signal is coupled into this socket and used only when the HAM SCAN-SPECTRUM ANALYZER switch is at the SPECTRUM ANALYZER position. This input is matched for 50 Ω coaxial cable.

20 dB ATTEN (20 dB Attenuation): When this switch is at the IN position, 20 dB of attenuation is connected to the RF INPUT socket and applied to the test signal.

IF INPUT-SIG GEN (Signal Generator) INPUT: This is the input socket for the IF signal from your receiver (the HAM SCAN-SPECTRUM ANALYZER switch must be in the HAM SCAN position). When the HAM-SCAN-SPECTRUM ANALYZER switch is in the SPECTRUM ANALYZER position, the signal from a variable frequency signal source, such as an RF signal generator, may be coupled into this socket.

HAM SCAN-SPECTRUM ANALYZER: With this switch at the HAM SCAN position, a sampling of your receiver's IF frequency may be coupled to the IF INPUT-SIG GEN socket of the Scana-lyzer.

When this switch is in the SPECTRUM ANALYZER position, the signal from a signal generator is coupled into the IF INPUT-SIG GEN socket. At the same time, a test signal is coupled into the RF INPUT socket. The signal generator frequency is chosen so the difference between it and the test signal is equal to the input frequency for which the Scana-lyzer is wired (IF frequency).

HORIZ WIDTH (Horizontal Width): Adjusts the length of the base line trace.

VERT POS (Vertical Position): Adjusts the position of the base line trace along the vertical axis. The trace is normally positioned behind the horizontal, calibrated base line.

LOG ADJ (Logarithmic Adjustment): Determines the operating point for the proper logarithmic characteristic of second IF amplifier V4. This control is adjusted only when the **AMPLITUDE SCALE** switch is set at the **LOG** position.

ASTIG (Astigmatism): This control (in conjunction with the **FOCUS** control) is adjusted only when there is a signal pip on the CRT screen to produce a clear, sharp trace.

SCANNING A BAND

() Plug the receiver IF output cable into the **IF INPUT** phono socket at the rear of the Scanalyzer.

Set the controls of the Scanalyzer as follows:

- () **HAM SCAN-SPECTRUM ANALYZER** switch: **HAM SCAN**.
- () **INTENSITY:** Turn the unit on with this control and set it for medium brightness of the display on the CRT.
- () **FOCUS:** Adjust for sharpest and clearest trace.
- () **VARIABLE SWEEP WIDTH:** Set the pointer at the previously calibrated 100 kHz bandwidth setting.
- () **PIP CENTER:** Center of rotation.
- () **PIP GAIN:** Fully clockwise.
- () **VARIABLE SWEEP RATE:** Fully counter-clockwise.
- () **HORIZ POS:** Center the trace horizontally on the screen.
- () **AMPLITUDE SCALE:** **LIN** position.
- () **SWEEP WIDTH:** **VARIABLE** position.

() Turn your receiver on and let it warm up. If it has an **RF gain** control, be sure it is set for maximum. Signal pips should appear along the CRT screen base line, indicating stations within the bandwidth being displayed.

() Adjust the **PIP CENTER** control to position the signal being heard at the center of the screen base line.

() Adjust the **PIP GAIN** control for the desired display height. **NOTE:** To observe signals of comparable amplitude (10:1 or less) the **AMPLITUDE SCALE** switch should be set to the **LIN** position. Examination of signals widely divergent in amplitude will require that this control be set in the **LOG** position, which will allow you to observe signals that differ as much as 40 dB in amplitude.

Operational Discussion

If your receiver has a crystal calibrator, tune the receiver so the tone is audible. Turn the calibrator on and off several times while turning the **PIP GAIN** control and watching the CRT screen. Position the calibrator signal pip at the center of the screen base line with the **PIP CENTER** control.

If it is impossible to center the calibrator signal pip with the **PIP CENTER** control, it can be assumed that the signal generator used to adjust coil L3 was off calibration. Therefore, it will be necessary to readjust coil L3 to position the calibrator signal pip to the center of the screen. Refer to **Oscillator And Mixer Alignment**, either Method 1 (Page 38) or Method 2 (Page 44).

In most **SSB** receivers a certain amount of **BFO** signal, called the **BFO** leakage signal, will appear as a stationary pip. This is unavoidable; however, it does provide a handy reference pip for proper centering. This pip will disappear if the receiver can be switched to the **AM** mode.

When a desired signal appears to move in a direction opposite to that expected, it is due to heterodyning circuitry of the receiver being used (whether the **HF** oscillator is positioned above or below the incoming signal).

False signals (birdies) may appear on the screen along with the signal pips. Birdies are usually receiver and Scanalyzer oscillator-mixer frequency products which fall in the band of the frequencies being viewed. Some of their characteristics are:

1. They are not audible when tuned to the center of the screen.
2. They move across the CRT screen at a different rate and/or direction than the audible signal pips.
3. They will appear with no antenna connected to the receiver.
4. They will appear when the receiver RF gain control is at minimum.

The amount of AGC (or AVC) developed by different receivers varies considerably. In one receiver the AGC may only affect the pip amplitude of the signal being heard, with those pips at either side of the audible pip remaining unchanged. In another receiver, the entire display will be affected. Generally, some level of AGC (in variable RF gain receivers) can be found that will provide both sufficient pip amplitude and normal AGC action in the receiver.

The overall frequency width displayed on the CRT can be checked at any time in the following manner: Tune the receiver (or calibrating instrument) to place a specific signal pip at one end of the screen base line and note the frequency of the receiver. Then tune the receiver to place this same pip at the other end of the screen and again note the receiver frequency. The overall displayed frequency width will be equal to the difference between these two frequencies.

The base line also can be calibrated by dividing the displayed frequency width by 10 to indicate the approximate frequency difference between the individual calibration marks. The approximate bandwidth of a signal can then be determined by using the calibration marks.

When calibrating the base line, use even numbered (100 kHz, 200 kHz, 500 kHz, etc.) bandwidths. Thus, the base line calibration marks can be interpolated to read frequency directly. For example, if the VARIABLE SWEEP WIDTH control is set for a 500 kHz bandwidth, each calibration

mark will be equal to 50 kHz. Additional examples:

200 kHz \div 10 = 20 kHz for each calibration mark.
 100 kHz \div 10 = 10 kHz for each calibration mark.
 50 kHz \div 10 = 5 kHz for each calibration mark.
 10 kHz \div 10 = 1 kHz for each calibration mark.

When a calibrating signal is used to mark the edges of the band, any out-of-band operation can be seen. This will be helpful if you contact DX stations whose operating frequency is outside of your authorized amateur bands.

The Scanalyzer, when used with a general coverage receiver, will locate harmonics and/or spurious radiation from your transmitter. Use a dummy load on the transmitter and no (or very little) antenna on the receiver. Set the SWEEP WIDTH control of the Scanalyzer to maximum. Key the transmitter and tune the receiver while watching the CRT screen (listen to the receiver also) for spurious signals and harmonics. This same method can also be used to null the carrier of a filter-type SSB transmitter or the unwanted sideband of a phasing-type transmitter.

In receivers using transformer coupling between the mixer and IF amplifier stages, the passband response may fall off sharply on both sides of the center (IF) frequency. In receivers using crystal or mechanical filters after the mixer stage, the response is quite flat for ± 50 kHz or more from the center (IF) frequency. The amplitude of the signal pips will therefore depend upon the receiver passband response. When tuning a receiver having a crystal or mechanical filter, the amplitude of the signal pip will decrease when it becomes audible. This is because the filter impedance becomes very low at its resonant frequency.

Narrow Band Analysis

Closer analysis of received on-the-air signals can be made if the sending transmitter uses constant carrier or steady tone modulation of the carrier. Because of the slower sweep rates in the 10 kHz or 50 kHz positions of the SWEEP WIDTH control, any quick amplitude variations could be missed. See Narrow Band Analysis, Page 62. Refer also to Spectrum Analyzer Applications, which follows.

IDENTIFYING CRT PATTERNS

If proper adjustments have been made, the signal being heard from the receiver will appear at the center of the screen base line. CW, AM, RTTY, SSB, and electrical interference signals may be identified as shown in Figures 28 through 36. The width of the signal pip will depend on the setting of the SWEEP WIDTH control.

Figure 28 - Normal SSB: Since an SSB signal is only present during modulation, the pip will appear only when there is modulation present. The pip outline will also have peaks and valleys corresponding to the many voice frequencies.

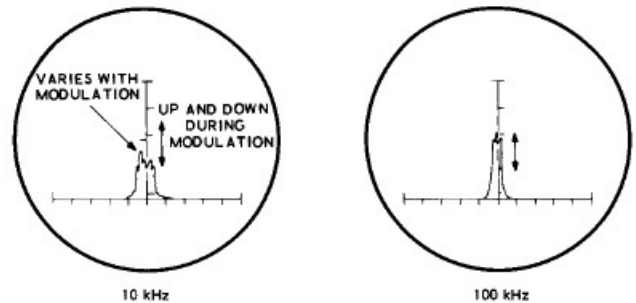

Figure 28

Figure 29 - Normal AM: Under no modulation the carrier will appear continuous. During modulation, the sides of the carrier will vary accordingly. These are the sidebands of an AM carrier.

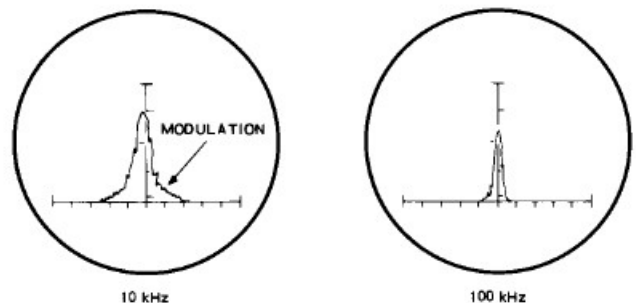

Figure 29

Figure 30 - CW: The pip of a CW signal will appear each time the transmitter is keyed. In the event of high speed CW, certain characters will not appear on the screen. This is due to the relatively slower sampling rate of the reactance modulator. In other words, a fast "dit" will appear in the receiver passband and disappear faster than all the signals in the passband are being sampled.

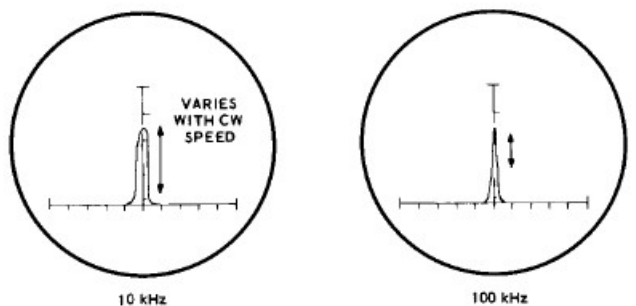

Figure 30

Figure 31 - Overmodulated AM: Very wide sidebands will appear with the carrier of an overmodulated AM signal. The approximate width can be measured by knowing the base line calibration.

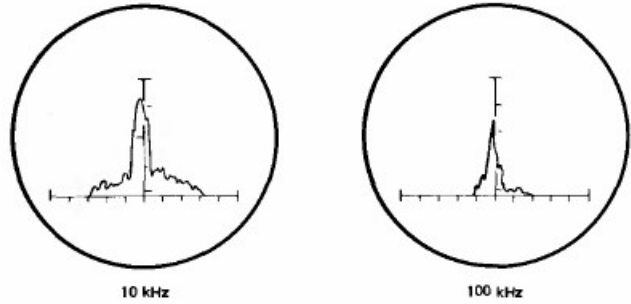

Figure 31

Figure 32 - Interfering AM Signals: The adjacent sidebands of two interfering AM signals will add and subtract giving the effect of a very wide AM signal with the center of the pip varying up and down. These two separate carriers may be seen if they are far enough apart in frequency.

Interfering SSB signals - two interfering SSB signals will appear as a single, wide SSB signal with each half varying up and down at different rates.

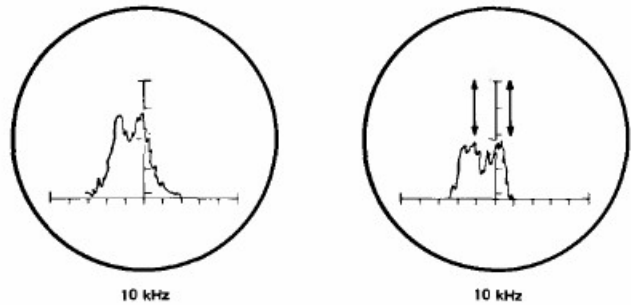

Figure 32

Figure 33 - RTTY: Teletype signals will appear as an unmodulated carrier with a slight amount of sideways shift and, depending on the type of RTTY system, a certain amount of vertical shifting.

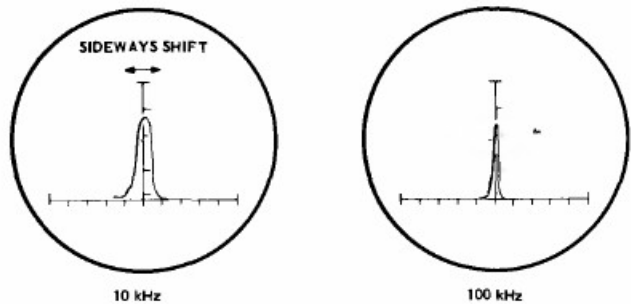

Figure 33

Figure 34 - Ignition Noise: Usually a series of sharp pulses that move back and forth or all in one direction.

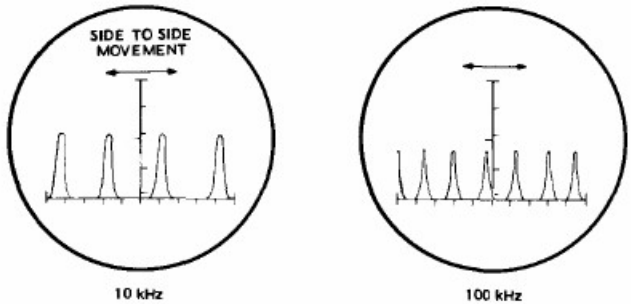

Figure 34

Figure 35 - Random Noise: This type of noise appears in numerous forms. Usually a noise pulse from electrical equipment, etc., is sharp and appears only briefly on the scope. A static burst is usually much wider, usually stationary on the screen, and lasts somewhat longer.

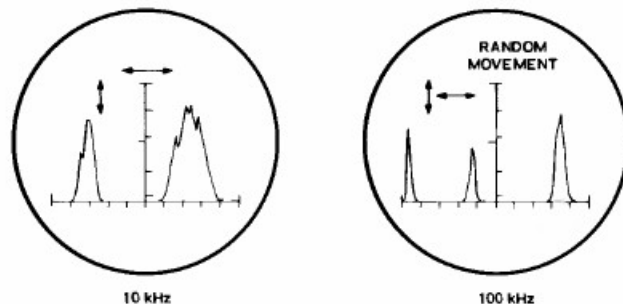

Figure 35

Figure 36 - Background Noise: This type of noise has the appearance of grass and is usually much lower in amplitude than the above types of noise. It gives a hissing sound in a speaker.

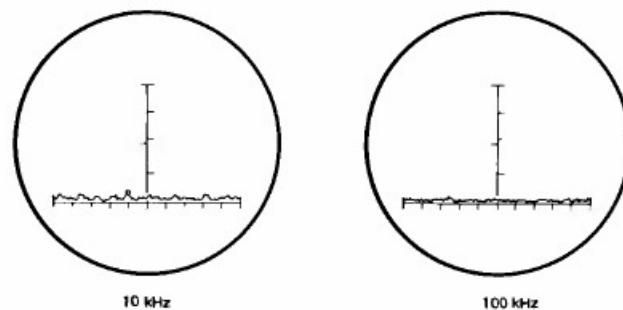

Figure 36

The Scanalyzer As A Basic Test Instrument

NOTE: A good quality RF signal generator that is stable and hum-free, and is capable of at least a 100 mV output, is required for the following type of operation.

The Scanalyzer, when used as a spectrum analyzer, can be used to check such things as oscillator stages for harmonic levels, parasitics, etc.; mixer stages for signal and oscillator feed-through and mixer products; and linear amplifiers for distortion products. See Figure 37 and refer to the following instructions.

- () Connect the output cable of the RF signal generator to the SIG GEN INPUT phono socket on the Scanalyzer,
- () Place the HAM SCAN-SPECTRUM ANALYZER switch at the SPECTRUM ANALYZER position,

- () Make up a test lead of small 50 Ω coaxial cable (not provided) with a phono socket installed at one end. See Figure 38. The cable should be long enough to reach from the Scanalyzer to the circuit being tested,

NOTE: Do not perform the next two steps if you intend to inductively couple the test signal to the free end of the input cable.

- () Connect a 51 Ω (green-brown-black) resistor between the center conductor and shield at the other end of the coaxial cable. See Figure 38.

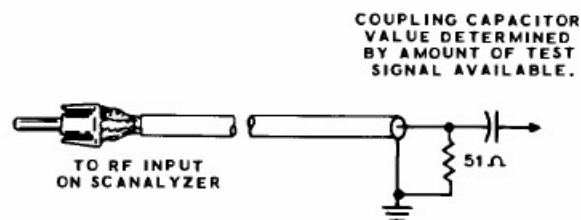

Figure 38

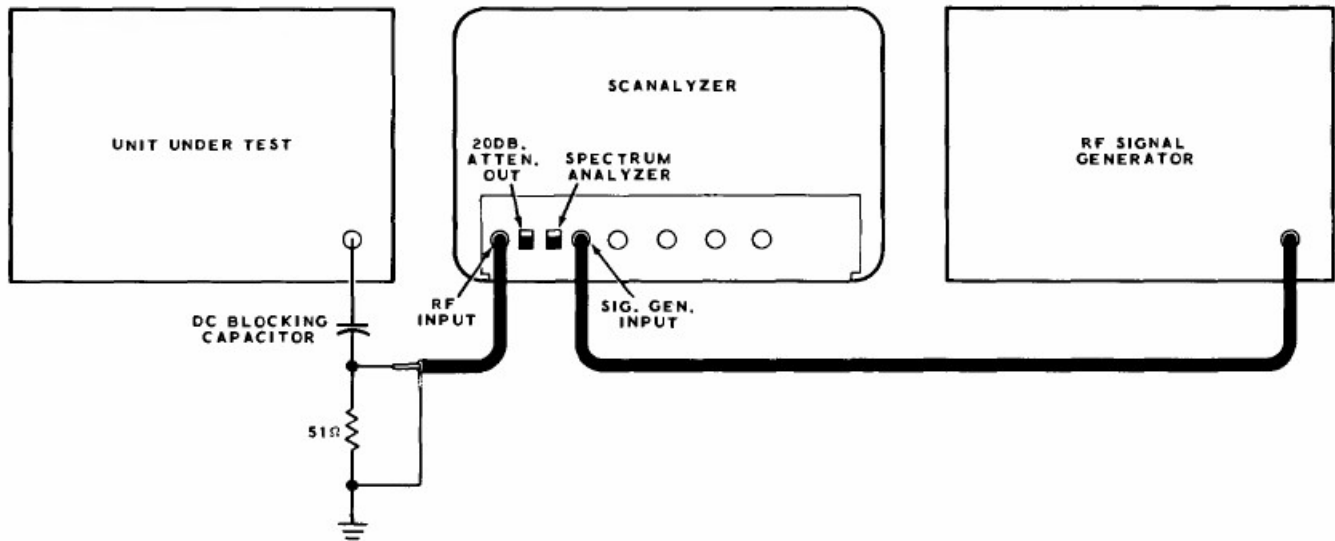

Figure 37

- () If the signal to be tested has a DC component, connect one lead of a blocking capacitor to the center conductor at this same end of the coaxial cable. See Figure 38.

NOTE: Disregard the next step if you performed the previous two steps.

- () For inductive coupling, connect a small loop of wire between the center conductor and shield at the open end of the coaxial cable. See Figure 39. The number of turns you will need in the loop will be determined by the amount of test signal available.

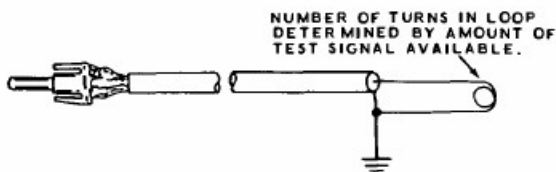

Figure 39

- () Plug the coaxial cable test lead into the RF INPUT phono socket on the Scanalyzer. Couple the other end of the test lead to the circuit under test.

The RF signal generator frequency should be set to the test signal frequency, plus the IF frequency for which the Scanalyzer is wired. For example, if the test signal to be observed is 3500 kHz and the Scanalyzer is wired for an IF of 455 kHz, then the signal generator is set at 3955 kHz (3500 kHz + 455 kHz) to place the test signal pip at the center of the CRT screen.

Another example could be a 50.1 MHz test signal with the Scanalyzer wired for an IF input frequency of 3395 kHz. The signal generator should then be set at a frequency of 53.495 MHz (50.1 MHz + 3.395 MHz).

The amplitude control on the RF signal generator should be set to insert at least 0.1 volt of signal into the Scanalyzer.

To locate the signal, it may be convenient to operate the Scanalyzer at maximum gain and the signal generator at a high output. Once the signal is located, the signal generator output should be decreased. Also, use the minimum amount of test signal into the Scanalyzer that will give sufficient pip amplitude on the CRT screen. The 20 dB ATTN switch may also be used to reduce the test signal input. Slowly search the spectrum by turning the signal generator until the signal appears at the center of the screen.

To find harmonics or spurious signals, follow the above procedure and slowly search the suspected band segment by turning the signal generator. **IMPORTANT:** Depending on the input frequency of the Scanalyzer and the signal generator being used, there could be spurious signals developed from a combination of the two units. Therefore, make a preliminary search of the band segment before applying the test signal in order to recognize any spurious signals that may be present.

NARROW BAND ANALYZER

When signals, or a carrier and its sidebands, are so closely spaced in frequency that at full sweep width their pips tend to merge together, it may be possible to separate or resolve them by placing the SWEEP WIDTH switch at the 50 kHz or, if necessary, at the 10 kHz positions. See Figures 40-1 through 40-8 (fold-out from Page 54), and Figures 40-9 through 40-13 (fold-out from Page 63). Resolution of 1 kHz or more is possible at the 10 kHz position. Maximum resolution of the Scanalyzer is with the SWEEP WIDTH switch in the 10 kHz position and with both the VARIABLE SWEEP RATE and VARIABLE SWEEP WIDTH controls at their full counterclockwise positions. (Resolution is defined as the frequency separation between two equal adjacent signals, such that the intersection between their respective pip indications is 30% below the apex amplitude.)

DISTORTION MEASUREMENT

To measure third-order distortion in an SSB (single-sideband) transmitter or exciter, modulate the transmitter with two audio tones of equal amplitude, with a difference frequency of the order of 1 kHz to 2 kHz. The RF output will consist of two signals separated by the audio difference frequency. If third-order distortion is present in the transmitter, spurious signals will appear that are higher and lower in frequency (by an amount equal to the difference frequency) than the two desired RF signals.

Your Scanalyzer can be used for third order distortion measurements as described in the following steps.

- () To display two RF signals on the screen, follow the procedure listed under the heading "The Scanalyzer As A Basic Test Instrument," and connect the test signal cables as shown in Figure 37, except that the connection between the unit under test and the Scanalyzer should be made as shown in Figure 41. **NOTE:** Be sure the two audio signals modulating the transmitter are low in harmonic content or that the two tones selected are such that their harmonics fall outside the passband of the filter in the transmitter.

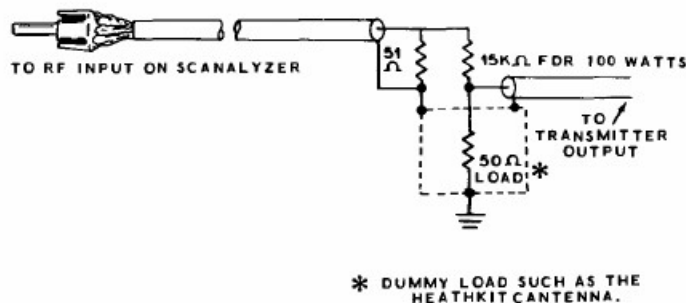

Figure 41

- () Set the SWEEP WIDTH switch at the 10 kHz position. Push in on the HORIZ POS control for the fast sweep and center the two pips on the screen with the PIP CENTER control.
- () Set the AMPLITUDE SCALE switch to the -20 dB LOG position. Adjust the PIP GAIN control until the pips are at the 0 dB mark on the vertical amplitude scale.
- () Set the AMPLITUDE SCALE switch to the LOG position. The CRT display now shows signals from -20 dB to -60 dB below the peak amplitude of the two input signals. The amplitude of third-order distortion pips can be read from the vertical scale on the CRT screen, adding 20 dB to account for the fact that the input signals are deflected 20 dB over full scale.

IN CASE OF DIFFICULTY

1. Recheck the wiring. Trace each lead in colored pencil on the Pictorial as it is checked. It is frequently helpful to have a friend check your work. Someone who is not familiar with the unit may notice something consistently overlooked by the builder.
2. About 90% of the kits that are returned for repair do not function properly due to poor connections and soldering. Therefore, many troubles can be eliminated by reheating all connections to make sure that they are soldered as described in the Soldering section of the Kit Builders Guide.
3. Check to be sure that all tubes are in their proper locations. Make sure that all tubes light up properly.
4. Check the tubes with a tube tester or by substitution of tubes of the same types known to be good.
5. Check the values of the parts. Be sure that the proper part has been wired into each point in the circuit, as shown in the pictorial diagrams and as called out in the wiring instructions.
6. Check for bits of solder, wire ends or other foreign matter which may be lodged in the wiring.
7. If, after careful checks, the trouble is still not located and a suitable meter is available, check resistance and voltage readings against those shown (fold-out from Page 64). NOTE: All voltage readings were taken with an 11 megohm input vacuum tube voltmeter. The use of a volt-ohm-milliammeter may load the circuit and result in a lower reading. Voltage and resistances may vary as much as 20%.
8. A review of the Circuit Description will help indicate where to look for trouble.
9. Refer to the Troubleshooting Chart on Page 65 for further help in locating causes of trouble.
10. Voltage and resistance measurements are given in Figures 42 (Page 64), 43, and 44 (fold-out from Page 64).

Refer to the Kit Builders Guide for service and warranty information.

SWEEP WIDTH

Place AMPLITUDE SCALE Switch in LIN position

AMPLITUDE SCALE

Place SWEEP WIDTH Switch in 10 kHz position

LUG	VAR		50 kHz		10 kHz	
	Volts	Ohms	Volts	Ohms	Volts	Ohms
16	-0.5	200 K	-0.5	200 K	-0.5	200 K
15		Inf		Inf		200 K
13		Inf		200 K		Inf
11		200 K		Inf		Inf
9	285	3 M	105	7.5 M	57	9 M
7		150 M		100 M		9 M
6		28 M		7.5 M		22 M
5		3 M		4 M		4.5 M
4	0	60	0.3	5 K	0.4	6.5 K
3		6.5 K		6.5 K		6.5 K
2		5 K		5 K		5 K
1		60		60		60

LUG	-20 DB LOG		LOG		LIN	
	Volts	Ohms	Volts	Ohms	Volts	Ohms
2	-3	500 K	0	0	0	0
1		0		0		0
12		0		0		0
11		500 K		500 K		500 K
10	-0.5	400 K	-0.5	400 K	0	0
9		0		0		0
8		350 K		350 K		350 K
7		350 K		350 K		350 K
6	0.5	100	0.5	100	0.7	100
5		70 K		70 K		100
4		100		100		100 K
3		100		100		100 K

FAST SWEEP SW VOLTS	
Open	Closed
445	362

Normal Reading at Center Lug:

HOR. POS.		VAR. SWEEP RATE	
Volts	Ohms	Volts	Ohms
70	450 K	60	9 M

NOTES:

- VOLTAGE AND RESISTANCE MEASUREMENTS TAKEN WITH A VTVM HAVING 11 MEGOHMS INPUT RESISTANCE WITH COMMON LEAD TO CHASSIS.
- RESISTANCES ARE IN OHMS.
K = 1000
M = 1,000,000
INF = INFINITY
- P DESIGNATES THE CONTACT FOR A POLE OF THE SWITCH.

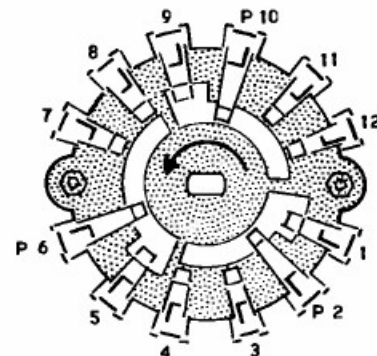
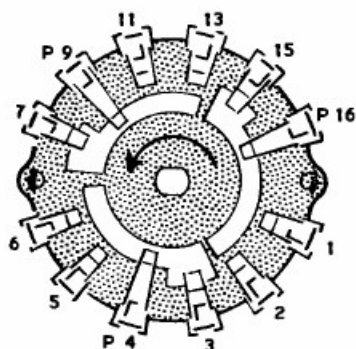

Figure 42

Troubleshooting Chart

SYMPTOMS	SUGGESTED CAUSE OR TEST
Tube filaments do not light; no B+ voltage.	<ol style="list-style-type: none"> 1. Open fuse in fuseholder. 2. Open switch on rear of Intensity control. 3. Power transformer wired incorrectly.
Tube filaments light but no B+ voltage.	<ol style="list-style-type: none"> 1. Power transformer wired incorrectly. 2. Defective silicon diode (D4 through D7) or diode incorrectly installed. 3. Open transformer winding.
Filaments in tubes V3, V4, and V6 light (AC) but filaments in tubes V1, V2, and V5 do not light.	<ol style="list-style-type: none"> 1. Defective silicon diode (D8 through D11) or diode incorrectly installed. 2. Filter capacitor C54 shorted or installed backwards.
Low B+ voltage.	<ol style="list-style-type: none"> 1. Shorted filter capacitor. 2. Open or incorrectly installed silicon diode.
No trace, regardless of control settings.	<ol style="list-style-type: none"> 1. Check voltage readings at CRT socket on lugs 6, 7, 9, and 10. NOTE: Observe extreme care as voltages are dangerously high. 2. Selenium diode D2 or D3 improperly connected or faulty.
Spot on CRT but no horizontal deflection.	<ol style="list-style-type: none"> 1. Check tube V6. 2. Check voltages on socket V6. 3. Check voltages at lugs 6 and 7 of CRT socket V7. 4. Sweep Width switch wired incorrectly. 5. Neon lamp NE-83-B defective or not "aged" long enough.
No vertical deflection.	<ol style="list-style-type: none"> 1. Check voltages at lugs 9 and 10 of CRT socket V7. 2. Check voltages on V1, V2, V3, V4, and V5. 3. Open transformer T1, T2, or T3. 4. Shorted or open receiver connector cable. 5. Improper connection to receiver. 6. Wired for wrong receiver IF frequency.
Sweep oscillator V2 not sweeping.	<ol style="list-style-type: none"> 1. Diode D1 defective or improperly connected. (Resistance of D1 when disconnected should be 10 to 15 Ω forward and 10 megohm or more reverse.) 2. Coil L3 improperly connected or open. 3. No sweep voltage from V6.

SYMPTOMS	SUGGESTED CAUSE OR TEST
Improper negative bias at D1.	<ol style="list-style-type: none"> 1. Diode D1 improperly connected or defective. 2. Open or wrong resistors connected to Pip Center control. 3. Defective Pip Center control. 4. Filter capacitor C1 shorted or installed backwards.
No sweep voltage to diode D1.	<ol style="list-style-type: none"> 1. Diode D1 improperly connected or defective. 2. Open or wrong resistors connected to Variable Sweep Width control. 3. Defective Variable Sweep Width control.
Poor focusing.	<ol style="list-style-type: none"> 1. Improper connections to Focus control, or defective control. 2. Check C47, C48, C49, R76, R78, and R79. NOTE: Some defocusing at the ends of the trace is normal and will not interfere with the Scanalyzer operation. 3. ASTIG control improperly adjusted.
Double pips from single input signal.	<ol style="list-style-type: none"> 1. Resistor R8 not grounded. 2. Variable Sweep Width control set at full clockwise position. 3. Signal input too strong.
Retrace line shows on CRT screen.	<ol style="list-style-type: none"> 1. Intensity set too high.
Pips appear on screen base line when Pip Center control is turned, or pips appear with no signal input.	<ol style="list-style-type: none"> 1. Defective Pip Center control. 2. Open or improper resistors connected to Variable Sweep Width control.
Pip distorted.	<ol style="list-style-type: none"> 1. Transformer T1, T2, or T3 not tuned properly. 2. Variable Sweep Rate control set too high.
CRT base line jumps abruptly while tuning receiver.	<ol style="list-style-type: none"> 1. Coil L1 improperly tuned. 2. Coil L1 open. 3. Capacitor C9 defective or not soldered.
CRT base line does not fill screen.	<ol style="list-style-type: none"> 1. Check voltages on V6. 2. Defective Horizontal Width control or incorrect value of resistance. 3. Capacitor C43 defective.

SPECIFICATIONS

RF AMPLIFIER

Input Frequencies (Receiver IF).....	One of the following: 455 kHz, 1000 kHz, 1600 to 1680 kHz, 2075 kHz, 2215 kHz, 2445 kHz, 3000 kHz, 3055 kHz, 3395 kHz, 5200 to 6000 kHz.
Frequency Response.	± 0.5 dB at ± 50 kHz from receiver IF.
IF Frequency.	350 kHz.
Sensitivity.	Approximately 10 μ v input signal provides a visible signal (40 dB mark) at full pip gain setting.
Spectrum Analyzer.	Test signal input frequencies up to 50 MHz.

HORIZONTAL DEFLECTION

Horizontal Sweep Generator.	Sawtooth sweep produced by neon lamp relaxation oscillator.
Sweep Rate (Approximate Frequencies).	10 kHz preset: 0.5 Hz. 50 kHz preset: 2 Hz to 2.5 Hz. Variable: 5 Hz to 15 Hz.
Preset Sweep Width.	10 kHz preset: 10 kHz. 50 kHz preset: 50 kHz.

Variable Sweep Width*.	<u>IF</u>	<u>SWEEP WIDTH</u>
	455 kHz	10 kHz to 100 kHz
	1000 kHz	50 kHz to 500 kHz
	1600 kHz	50 kHz to 500 kHz
	1680 kHz	50 kHz to 500 kHz
	2075 kHz	50 kHz to 500 kHz
	2215 kHz	50 kHz to 500 kHz
	2445 kHz	50 kHz to 500 kHz
	3000 kHz	100 kHz to 500 kHz
	3055 kHz	100 kHz to 500 kHz
	3395 kHz	100 kHz to 500 kHz
	5200 kHz	100 kHz to 500 kHz
	6000 kHz	100 kHz to 500 kHz

*These sweep widths are minimum values. Actual sweep width ranges will be greater than those listed, depending on the receiver IF frequency for which unit is wired.

Resolution.	1 kHz.
	NOTE: Resolution is defined as the frequency separation between two equal adjacent signals such that the intersection between their respective pip indications is 30% below the apex amplitude.
Amplitude Scales.	Linear: 20 dB (10:1) range. Log: 40 dB (100:1) range. -20 dB Log: (Extends calibrated range to 60 dB)
POWER SUPPLY	
Type.	Transformer operated; fused at 1/2 ampere.
Low Voltage.	Full-wave voltage doubler circuit, using four silicon diodes.
High Voltage.	Full-wave voltage doubler circuit, using two selenium diodes.
Bias Voltage.	Full-wave bridge circuit, using four silicon diodes.
Power Requirements.	120 or 240 volts AC, 50/60 Hz, 40 watts.
GENERAL	
Tube Complement.	1 - 3RP7 CRT, high persistence (yellow trace with screen filter). 1 - 6AT6, detector vertical amplifier. 1 - 6AU6, IF Log amplifier. 1 - 6EA8, sweep oscillator, mixer. 1 - 6EW6, RF amplifier. 1 - 6EW6, IF amplifier. 1 - 12AU7, horizontal, push-pull amplifier.
Diode Complement.	8 - Silicon diodes, low voltage rectifier, DC filament rectifier. 2 - Selenium diodes, high voltage rectifiers. 1 - Silicon diode, voltage-variable capacitor.
Cabinet Dimensions.	6-5/8" high x 10" wide x 10-1/2" deep.
Net Weight.	10 lbs.

The Heath Company reserves the right to discontinue instruments and to change specifications at any time without incurring any obligation to incorporate new features in instruments previously sold.



CIRCUIT DESCRIPTION

Refer to the Schematic (fold-out from Page 75) and the Block Diagram below while reading this Circuit Description. NOTE: The Schematic Diagram shows three possible RF amplifier-to-mixer coupling circuits. The one used will depend on the IF frequency of your receiver.

Basically, the Scanalyzer is a receiver combined with an oscilloscope. The mixer stage of the Scanalyzer is automatically swept across a band of frequencies that centers around the IF passband of the receiver to which it is connected. Each of the received signals in this IF passband is then tuned in for a moment as the high frequency (mixer) oscillator sweeps by it; the received signals are then displayed in the form of vertical pips on the cathode ray tube.

RF AMPLIFIER

The band of frequencies to be viewed is centered on your receiver's IF frequency. Input signals are taken from the receiver's mixer plate and coupled through capacitor C_c to the grid of RF amplifier tube V1 (the response of most receivers is usually quite broad at the mixer plate). The Pip Gain control in the grid circuit of V1 controls the amount of signal applied, thereby controlling the height of the pip displayed on the CRT screen. Coil L1 and capacitor C1 form a trap circuit which effectively shorts to ground any 350 kHz signal at the input (350 kHz is the IF frequency of the Scanalyzer.)

The signal from V1 is coupled to mixer tube V2A through one of the three coupling circuits shown at the bottom of the Schematic. A tuned circuit, RFC 1 and its capacitor C14 (Optional mixer circuit #1), is used only when the Scanalyzer is operated with receivers with a 455 kHz IF. This circuit is tuned to about 420 kHz to restore the amplitude of the signal in this frequency area and compensate for any attenuation due to the 350 kHz trap. A bandpass filter with a bandwidth of 500 kHz (#2) is used when the Scanalyzer is operated with receivers having an IF of 3395 kHz. This circuit will attenuate most unwanted signals from the receiver that may enter the instrument and cause "birdies" to appear on the screen. All other receiver IF frequencies use only resistive coupling, as shown by resistor R31 in coupling circuit #3.

When the Scanalyzer switch is placed in the Spectrum Analyzer position, the cathode bypass capacitor for V1 is removed from the circuit. RF amplifier stage V1 then becomes a mixer with a test signal injected on its cathode and an external signal generator coupled to its grid circuit. The signal generator frequency is selected to mix with the test signal frequency to produce the receiver IF frequency for which the front end of the Scanalyzer is wired. A 20 dB attenuator switch is incorporated in the RF input (cathode) circuitry.

SWEEP OSCILLATOR V2B

The high frequency oscillator signal that is coupled to mixer tube V2A is supplied by the sweep oscillator circuit of tube V2B. Tube V2B

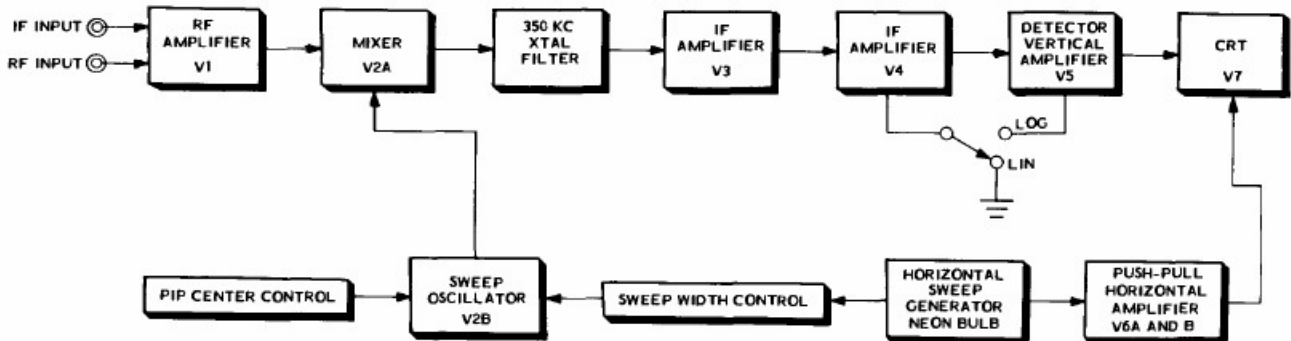

BLOCK DIAGRAM

is connected as a Hartley oscillator, except that the voltage-variable capacitance of diode D1 is used to sweep modulate the tuned circuit of coil L3 and capacitor C4. The capacitance of D1, and therefore the oscillator frequency, is altered at a regular rate by a portion of the horizontal sawtooth sweep voltage, which is coupled to it through a section of the horizontal Sweep Width switch, resistor R3, Variable Sweep Width control R4, and resistor R9. Bias is supplied to diode D1 through the Pip Center control.

The plate voltage of V2B is regulated to provide oscillator stability by neon lamp NE-83-A. This lamp is also used for the "ON" indicator of the unit.

The sweep width is determined by the amplitude of the sawtooth voltage that is applied to diode D1, which is controlled by the setting of the variable Sweep Width control and Sweep Width switch.

MIXER

The amplified receiver IF signal at the plate of RF amplifier V1 is coupled through the required coupling circuit and through capacitor C23 to the grid of V2A. The plate circuit of V2A is tuned to 350 kHz by a crystal filter consisting of transformer T1 and crystals Y1 and Y2. The 350 kHz IF signal therefore, at any given instant, will originate in the mixer as the difference frequency between the instantaneous sweep oscillator frequency and any input RF signal that is exactly 350 kHz away. As the sweep oscillator frequency changes, different input signals will be coupled through the Scanalyzer to the cathode ray tube, where they will be presented as vertical pips.

CRYSTAL FILTER AND IF AMPLIFIERS

Bifilar transformer T1 and crystals Y1 and Y2 form a half-lattice filter that provides extremely good resolution for an instrument of this type. The frequency spacing of Y1 and Y2 result in an IF bandwidth of approximately 210 Hz at the 6 dB points. The first IF stage, V3, is a conventional IF amplifier except for the cathode circuit. A fixed value of resistance in the cathode circuit is selected by a section of the Sweep Width switch to control the gain of this stage when selecting different sweep widths. A negative bias voltage is applied to the grid of this stage when the Amplitude Scale switch is placed in the -20 dB Log position.

The second IF stage, V4, is similar to the first IF stage, except at the Log setting of the Amplitude Scale switch a DC feedback voltage from the detector is applied to the grid of V4 to reduce its gain for strong signals. The chassis mounted Log-Adjust control determines the magnitude of the feedback voltage and the operating point of the IF stage which controls the logarithmic characteristic.

DETECTOR

The amplified 350 kHz signals from V4 are passed through IF transformer T3 to the diode plate of detector V5. The output of the detector is direct-coupled to the grid of V5 through a low-pass RC filter consisting of capacitor C38, resistor R53, and combinations of capacitors C39, C41, and C42, which are selected by a section of the Sweep Width switch. This switch section provides a different degree of hum filtering for each switch position.

HORIZONTAL SAWTOOTH GENERATOR AND AMPLIFIER

Neon lamp NE-83-B, resistors R56 and R57, the Variable Sweep Rate control, and capacitor C43 function as a relaxation-type sawtooth oscillator. At the beginning of each cycle, capacitor C43 begins to charge up to the supply voltage. Since the supply voltage is nearly ten times the firing voltage of the neon lamp, the voltage rise is quite linear.

When its firing voltage (about 70 volts) is reached, the lamp fires and the stored energy in the capacitor is quickly discharged through the lamp. When the extinguishing voltage is reached, the lamp goes out, capacitor C43 begins to charge again, and a new cycle begins.

This sawtooth voltage waveform is coupled through the Horizontal Width control (rear apron) to the grid of horizontal push-pull amplifier stage V6A. The Horizontal Width control determines the amount of sawtooth voltage to be amplified. The sawtooth voltage waveform is coupled to V6B through a common cathode connection, which produces the proper phase relationship for push-pull amplification.

The amplified sweep voltage at the plates of V6A and V6B is coupled directly to the horizontal deflection plates of the CRT, V7. Capacitor C46 couples the sweep voltage back to sweep oscillator circuit V2B.

POWER SUPPLY

All B+ voltages are provided by a full-wave voltage doubler circuit. This circuit uses four silicon diodes, D4 through D7. Resistors R81, R82, and R83, capacitors C51 and C52, and four-section capacitor C53 make up the B+ filtering network. The -1500 volts DC required by the CRT is provided by selenium rectifiers D2 and D3, capacitors C47, C48, and C49, and resistor R79 in a full-wave voltage doubler circuit.

A 6.3 volt filament winding on power transformer T4 provides AC filament power for tubes V3, V4, and V6. A bridge rectifier, consisting of silicon diodes D8 through D11, provides DC filament voltage for tubes V1, V2, and V5 to keep the hum level on the signal down to a minimum. This is particularly important when using the slow sweep rate and narrow band width for narrow band analysis. The bias voltage that is applied to diode D1 in the sweep oscillator circuit and to the grid of IF amplifier stage V3 for the -20 dB Log position, is also derived from this circuit.

IF CHART

RECEIVER IF (kHz)	OSCILLATOR COIL L3	R1 (10 kHz)	R2 (50 kHz)	C3	C4
455	40-775*	820 K	100 K	260	75
1000	40-775*	10 M	100 K	260	None
1600	40-808	10 M	1.5 M	470	56
1680	40-808	10 M	1.5 M	470	56
2075	40-808	10 M	1.5 M	470	56
2215	40-808	10 M	1.5 M	470	56
2445	40-808	18 M	1.5 M	470	56
3000	40-776	22 M	3.3 M	470	56
3055	40-776	22 M	3.3 M	470	56
3395	40-776	22 M	5.6 M	470	56
5200	40-807	22 M	5.6 M	470	56
6000	40-807	32 M (22 + 10)	10 M	470	56

*A value of 260 pf (two 130 pf capacitors in parallel) is used at C3 with coil 40-775.
 Capacitors are shown in pf.
 Resistors are shown in ohms (K = 1000, M = 1,000,000).

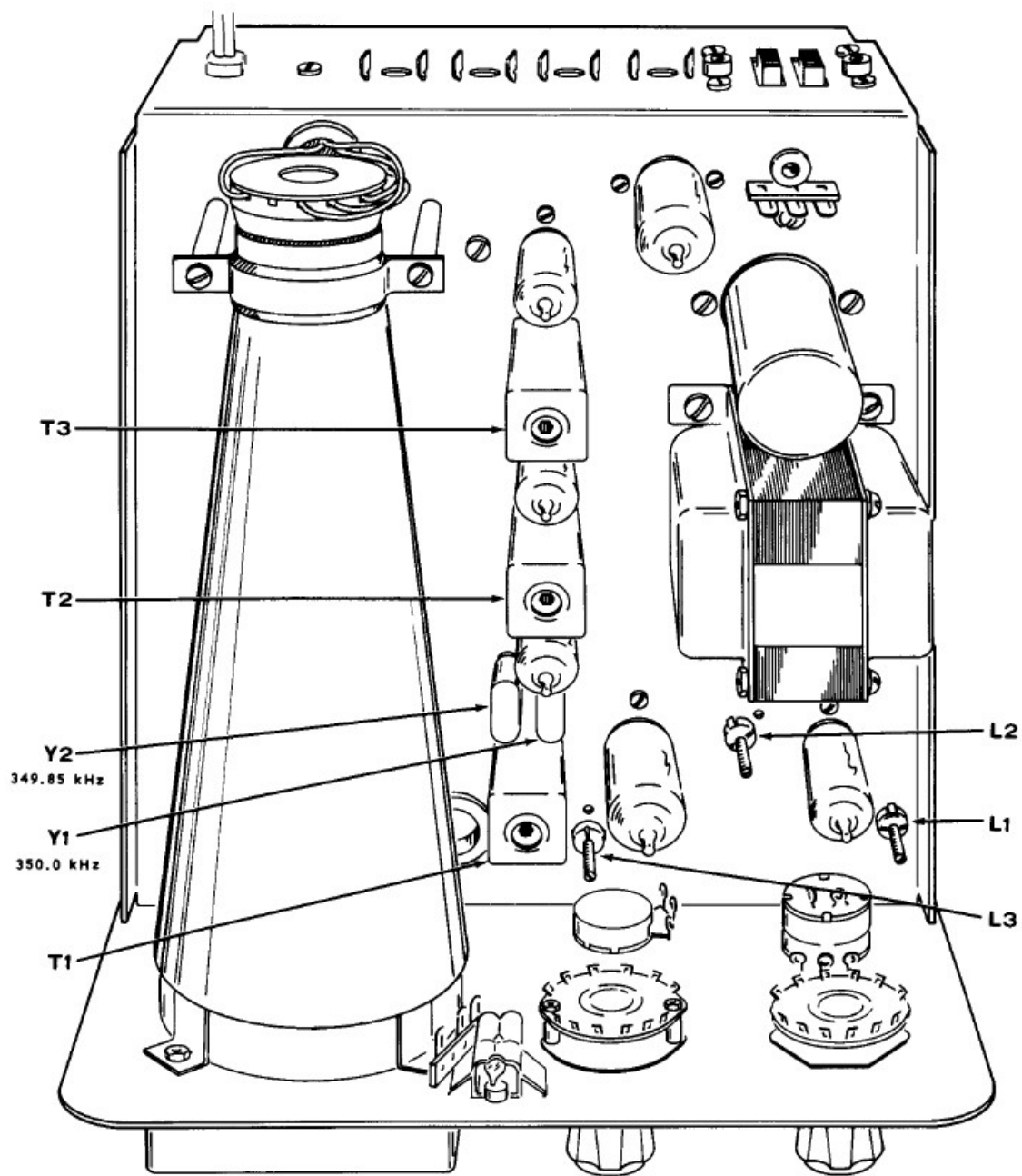
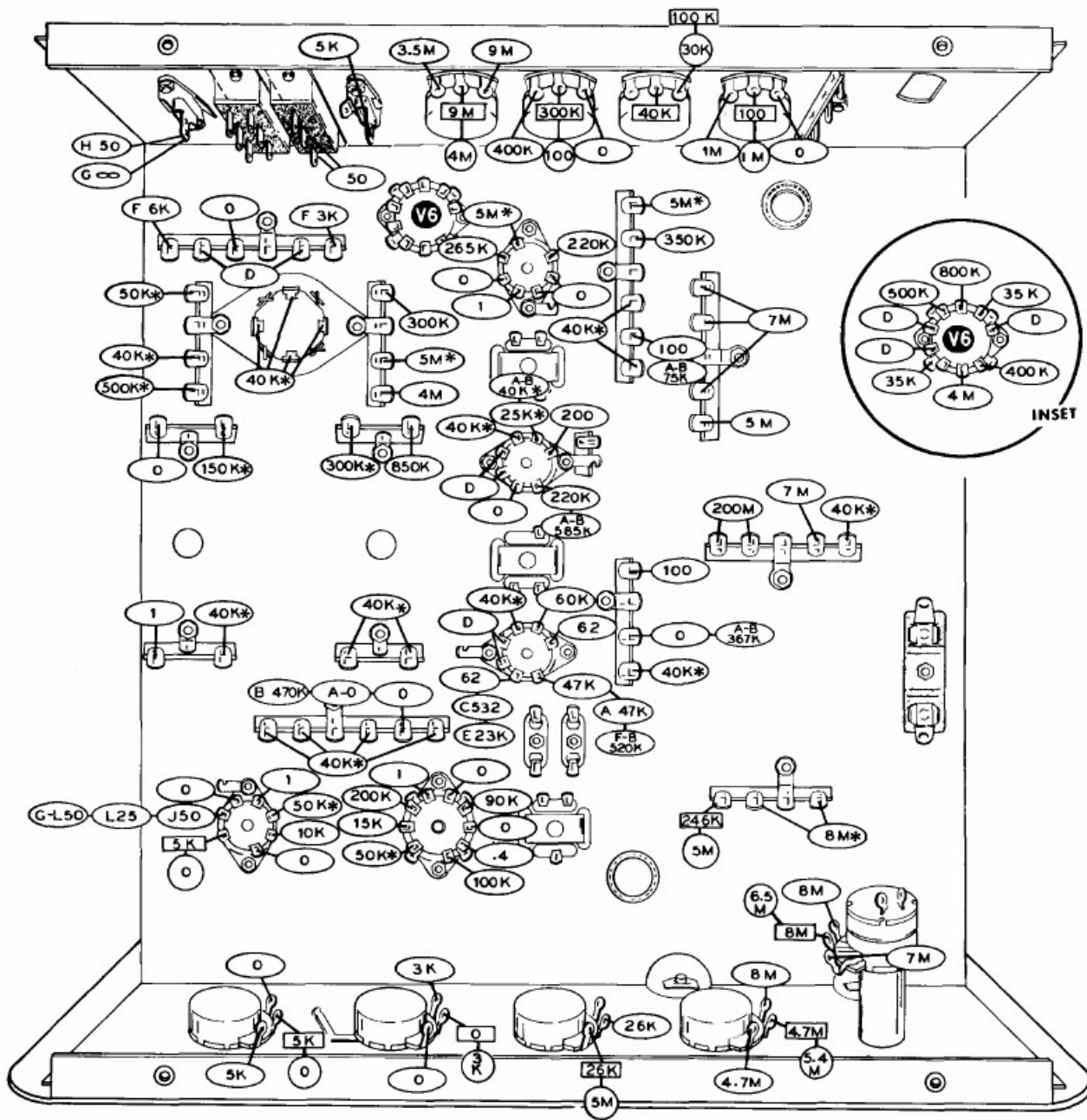

FIGURE 4



NOTES:

1. MEASUREMENTS MADE IN OHMS WITH A VTVM HAVING 11 MEG-OHMS INPUT RESISTANCE. COMMON LEAD TO CHASSIS GROUND. (K = 1000, M = 1,000,000). RESISTANCES MAY VARY 20%.
 2. CONTROLS POSITIONED AS FOLLOWS VIEWED FROM KNOB END OF SHAFT.
 - = FULLY COUNTERCLOCKWISE
 - ◻ = FULLY CLOCKWISE
 3. ○ = RESISTANCE READING AT POINT INDICATED.
- * BEFORE READING THE METER IN A CIRCUIT INVOLVING LARGE FILTER CAPACITORS, WAIT A FEW MOMENTS UNTIL THE OHM-METER NEEDLE HAS ALMOST STOPPED MOVING.

CONDITIONS:

- AMPLITUDE SCALE SWITCH NORMALLY IN THE "LIN" POSITION UNLESS THE LEGEND BELOW INDICATES OTHERWISE.
- SWEEP WIDTH SWITCH NORMALLY IN THE "VARIABLE" POSITION UNLESS THE LEGEND BELOW INDICATES OTHERWISE.
- A. AMPLITUDE SCALE SWITCH IN "LOG" POSITION.
 - B. AMPLITUDE SCALE SWITCH IN "-20 DB LOG" POSITION.
 - C. SWEEP WIDTH SWITCH IN "50 kHz" POSITION.
 - D. BECAUSE OF THE SOLID STATE DIODES USED IN THESE CIRCUITS, READINGS WILL VARY DEPENDING ON OHMMETER RANGE SELECTED AND TYPE OF OHM-METER USED.
 - E. SWEEP WIDTH SWITCH IN "10 kHz" POSITION.
 - F. INDICATES THERE IS A CONTROL IN THE CIRCUIT, AND THAT READINGS MAY VARY DEPENDING ON THE CONTROL SETTING.
 - G. 20 DB ATTN SWITCH AT THE "OUT" POSITION.
 - H. 20 DB ATTN SWITCH AT THE "IN" POSITION.
 - J. HAM-SCAN SPECTRUM ANALYZER SWITCH AT THE "HAM SCAN" POSITION.
 - L. HAM-SCAN SPECTRUM ANALYZER SWITCH AT THE "SPECTRUM ANALYZER" POSITION.

FIGURE 43

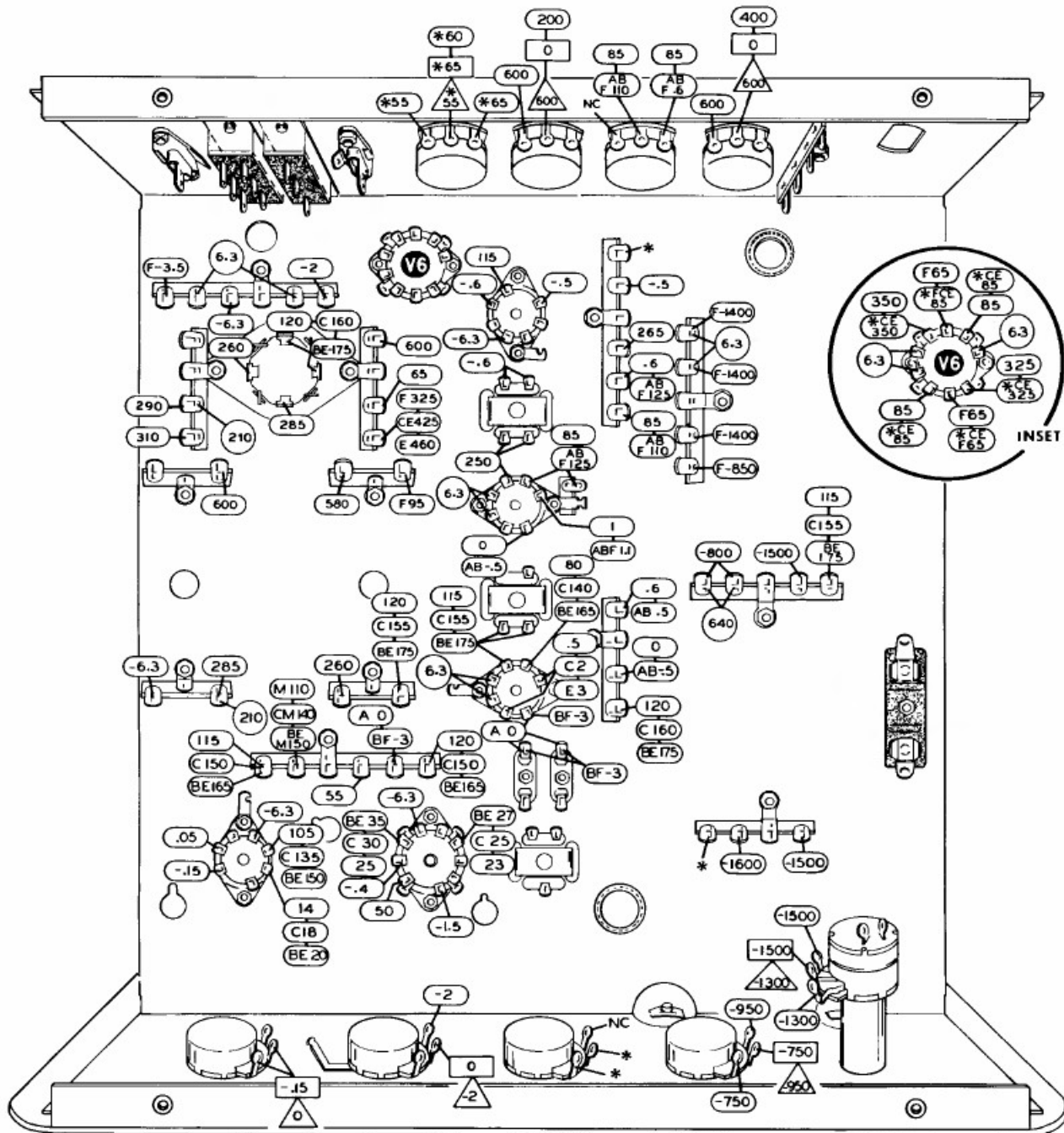

NOTES:

1. MEASUREMENTS MADE WITH A VTVM HAVING 11 MEGOHMS INPUT RESISTANCE, WITH COMMON LEAD TO CHASSIS AND POLARITY REVERSING SWITCH.

2. CAUTION: HIGH NEGATIVE VOLTAGES ARE FOUND AT MANY POINTS - TAKE PROPER PRECAUTIONS IN HANDLING THE CHASSIS AND IN CONNECTING YOUR VOLTMETER.

3. VOLTAGE LEGEND:
CONTROLS VIEWED FROM KNOB END OF SHAFT:

- △ = DCV, FULLY COUNTERCLOCKWISE.
- = DCV, FULLY CLOCKWISE.
- = NORMAL OPERATING DCV.
- ◌ = AC VOLTS MEASURED BETWEEN POINTS INDICATED.

* BECAUSE OF THE SAWTOOTH WAVEFORM AT THESE POINTS, THE DC VOLTAGE WILL FLUCTUATE.

CONDITIONS:

AMPLITUDE SCALE SWITCH NORMALLY IN THE "LIN" POSITION UNLESS THE LEGEND BELOW INDICATES OTHERWISE.

SWEEP WIDTH SWITCH NORMALLY IN THE "VARIABLE" POSITION UNLESS THE LEGEND BELOW INDICATES OTHERWISE.

- A. AMPLITUDE SCALE SWITCH IN "LOG" POSITION.
- B. AMPLITUDE SCALE SWITCH IN "-20DB LOG" POSITION.
- C. SWEEP WIDTH SWITCH IN "50 KHz" POSITION.
- D. BECAUSE OF THE SOLID STATE DIODES USED IN THESE CIRCUITS, READINGS WILL VARY DEPENDING ON OHMMETER RANGE SELECTED AND TYPE OF OHMMETER USED.
- E. SWEEP WIDTH SWITCH IN "10 KHz" POSITION.
- F. INDICATES THERE IS A CONTROL IN THE CIRCUIT, AND THAT READINGS MAY VARY DEPENDING ON THE CONTROL SETTING.
- G. 20 DB ATTEN SWITCH AT THE "OUT" POSITION.
- H. 20 DB ATTEN SWITCH AT THE "IN" POSITION.
- J. HAM-SCAN SPECTRUM ANALYZER SWITCH AT THE "HAM SCAN" POSITION.
- L. HAM-SCAN SPECTRUM ANALYZER SWITCH AT THE "SPECTRUM ANALYZER" POSITION.
- M. THIS VOLTAGE WILL BE "0" FOR ALL IF FREQUENCIES EXCEPT 455 KHz AND 3345 KHz.

FIGURE 44

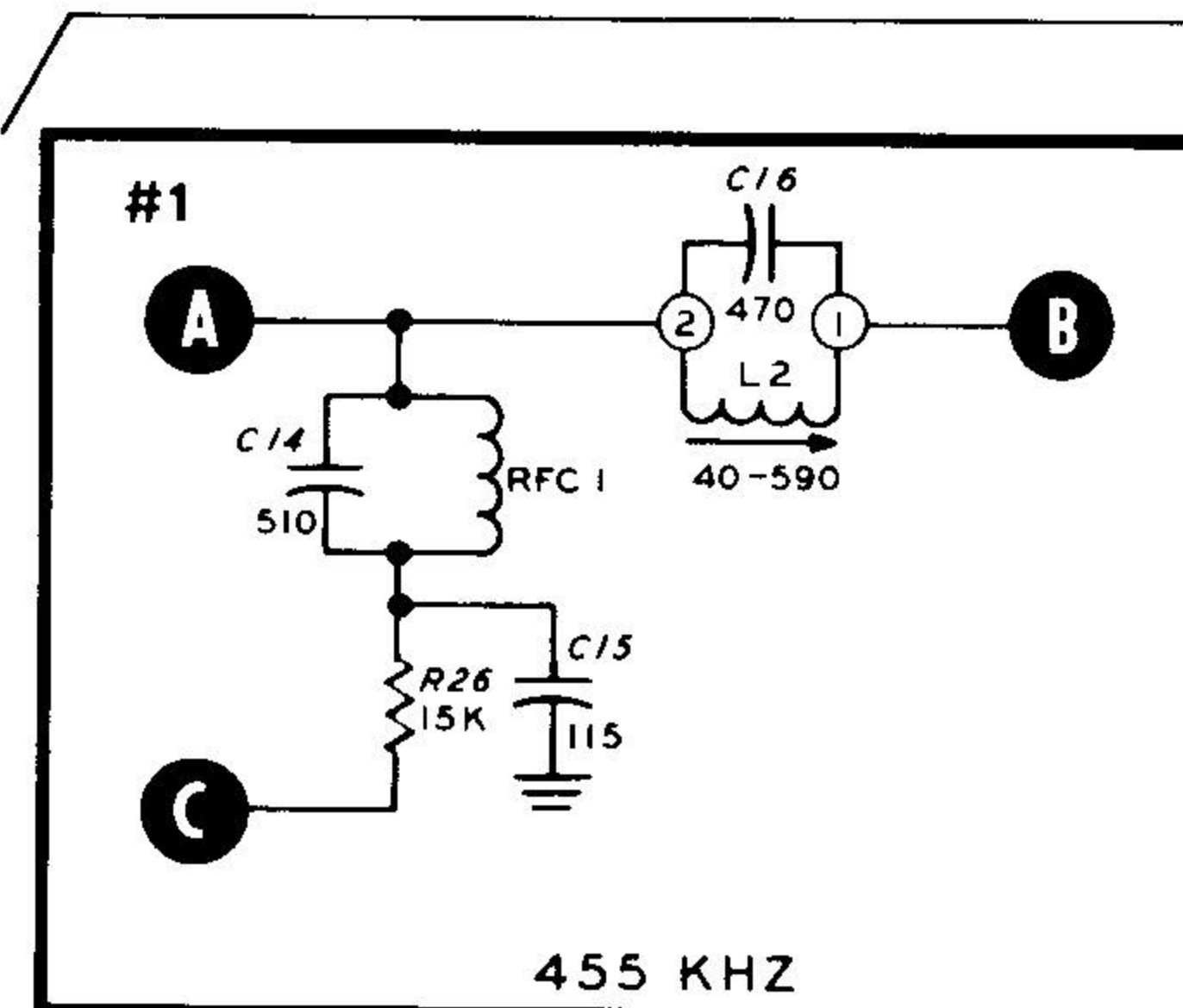
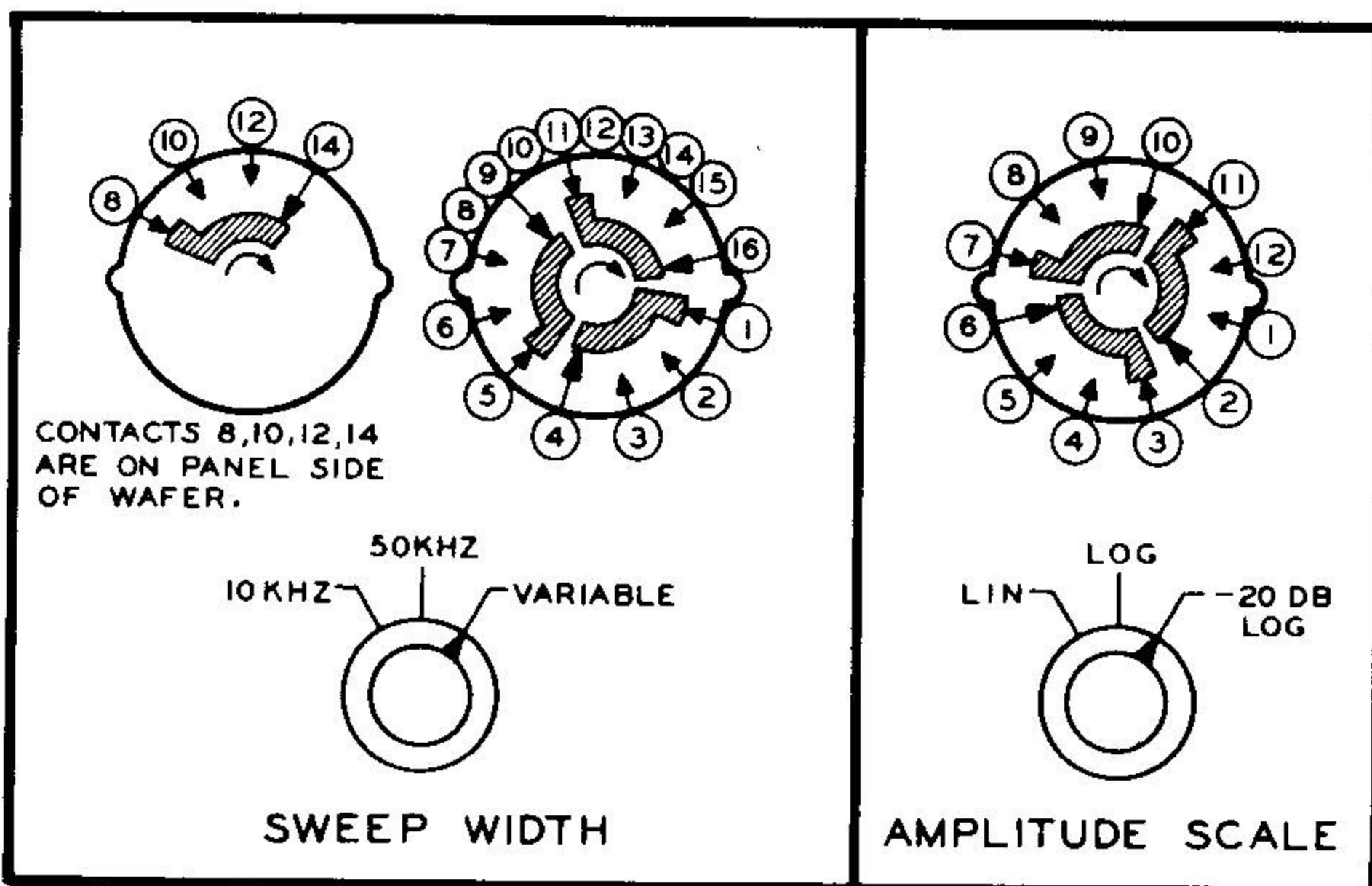
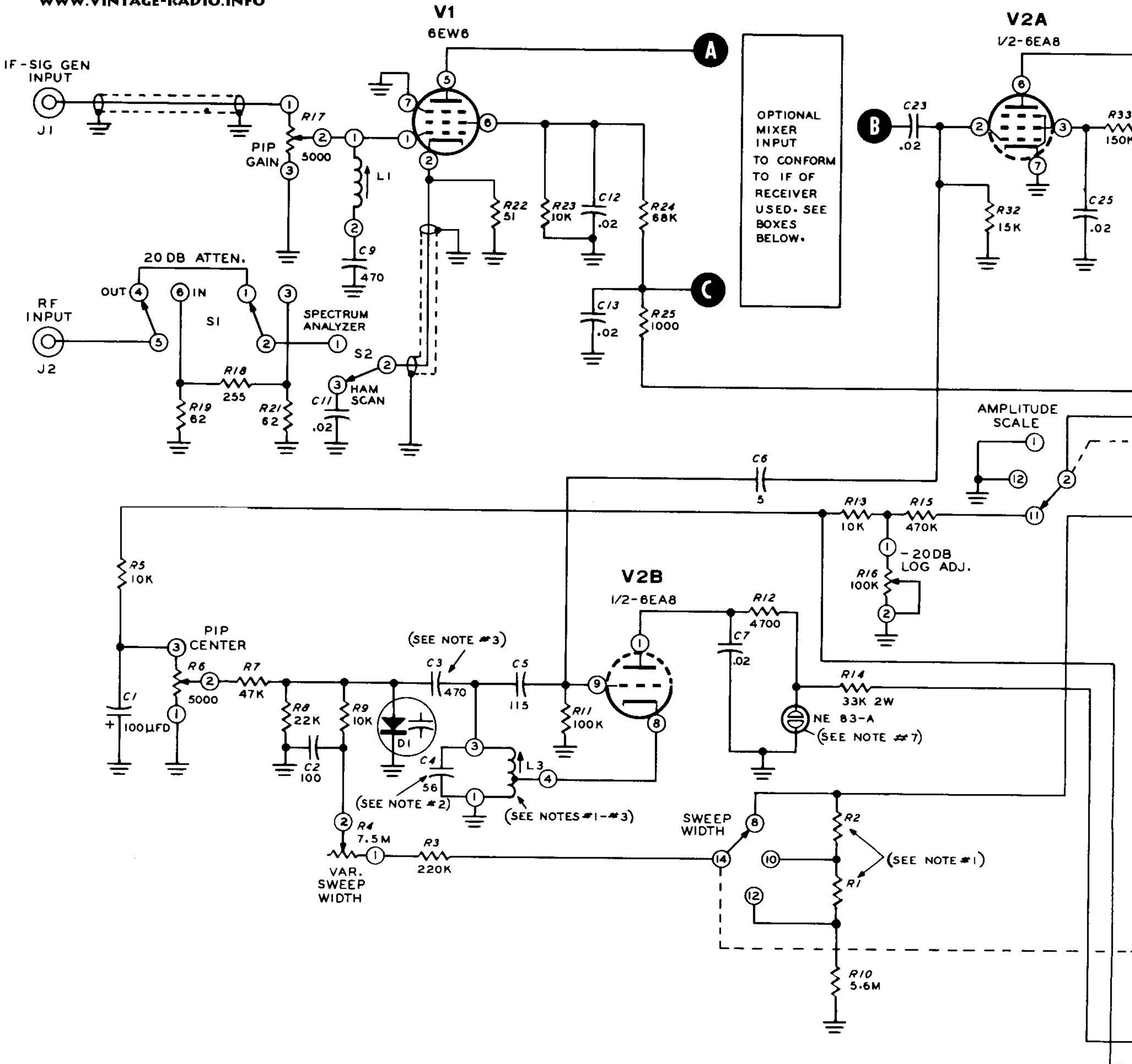

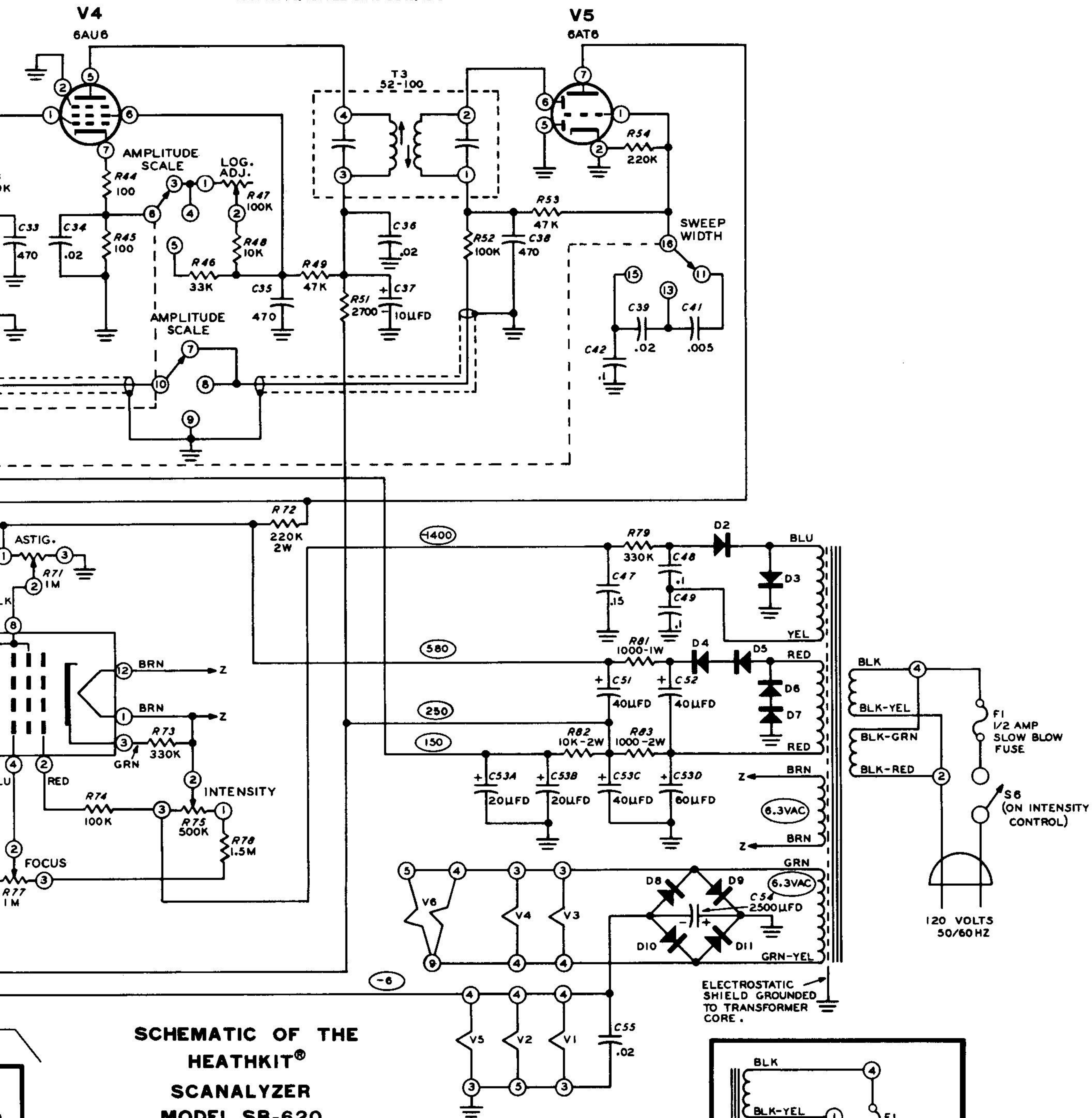

**SCHEMATIC OF THE
HEATHKIT®
SCANALYZER
MODEL SB-620**

NOTES:

1. SEE IF CHART ON PAGE 75.
2. A. NO CAPACITOR USED ACROSS L3 WHEN WIRED FOR 1000 kHz.
B. WHEN WIRED FOR A RECEIVER IF FREQUENCY OF 455 kHz, C4 IS 75 pf.
3. WHEN OSCILLATOR COIL 40-775 IS USED AT L3, CHANGE C3 TO 260 pf.
4. CAPACITOR VALUES LESS THAN 1 ARE IN μ fd. VALUES OF 1 AND ABOVE ARE IN pf UNLESS OTHERWISE MARKED.
5. ALL RESISTORS ARE 1/2 WATT UNLESS OTHERWISE MARKED. RESISTOR VALUES ARE IN OHMS (K = 1000, M = 1,000,000).
6. SWITCH WAFERS ARE SHOWN IN FULL COUNTERCLOCKWISE ROTATION AS VIEWED FROM THE REAR. ARROWS SHOW DIRECTION OF COUNTERCLOCKWISE KNOB ROTATION.
7. NE-83-A, VOLTAGE REGULATOR, IS ALSO USED AS THE PANEL "ON" INDICATOR.

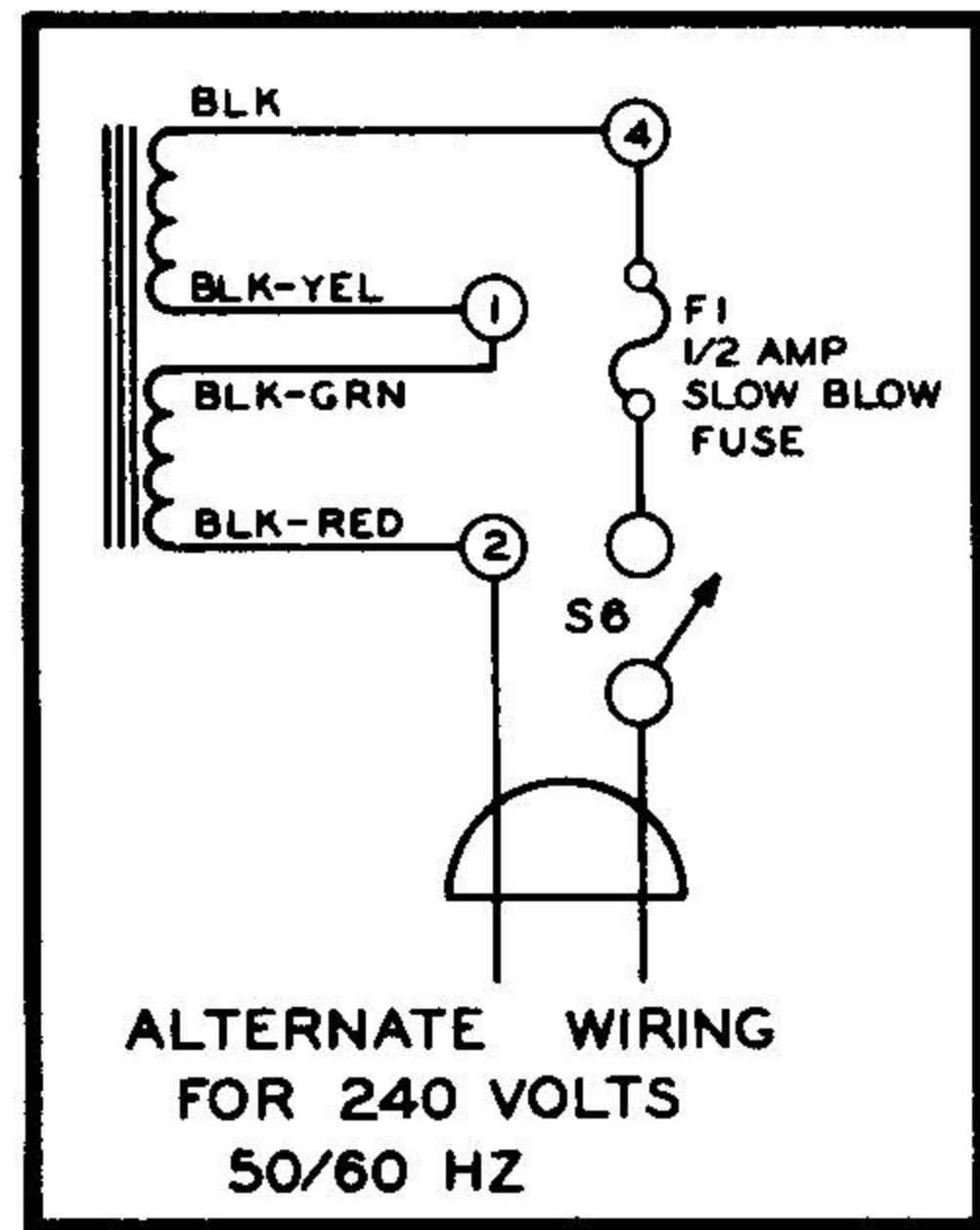

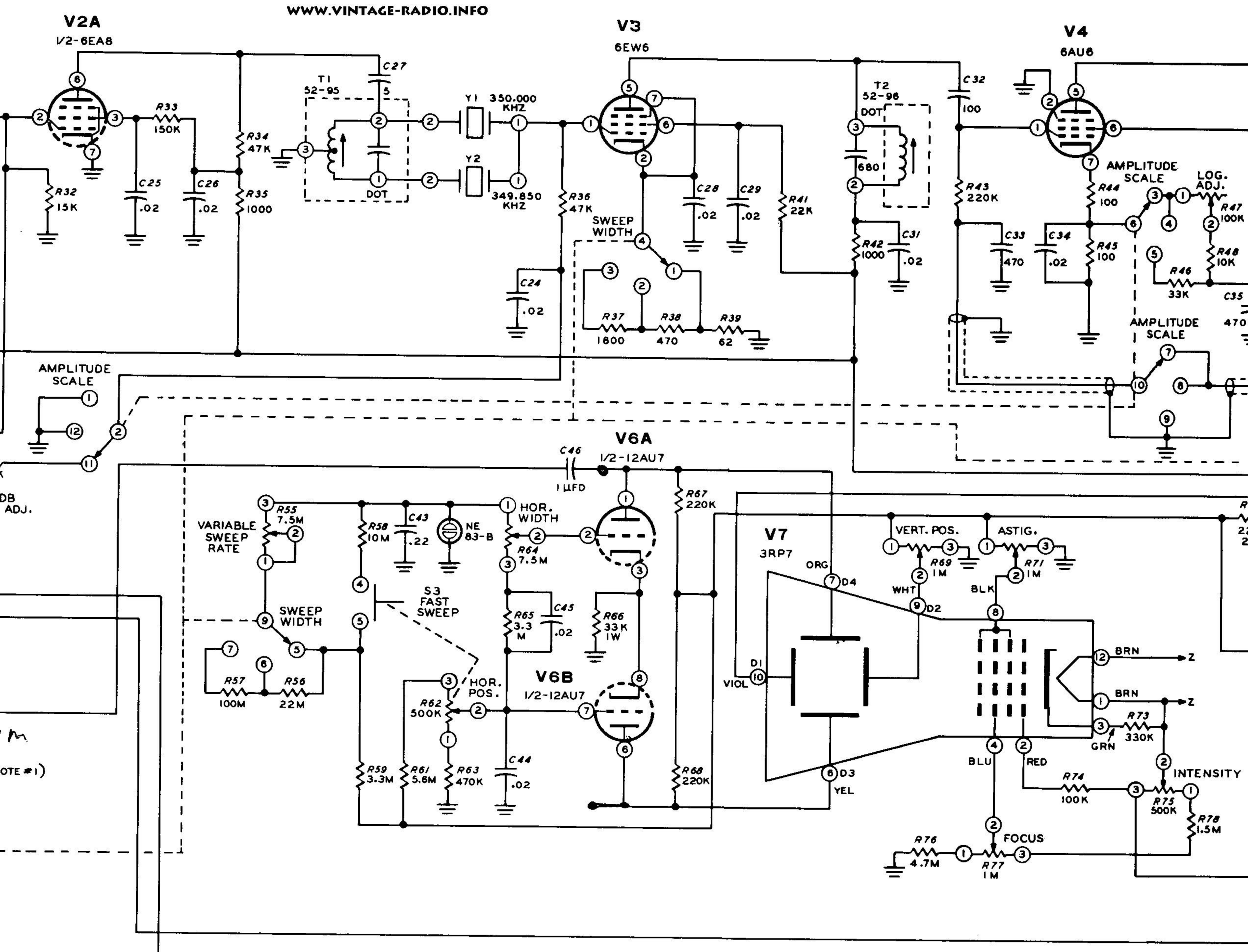

OPTIONAL MIXER INPUT CIRCUITS

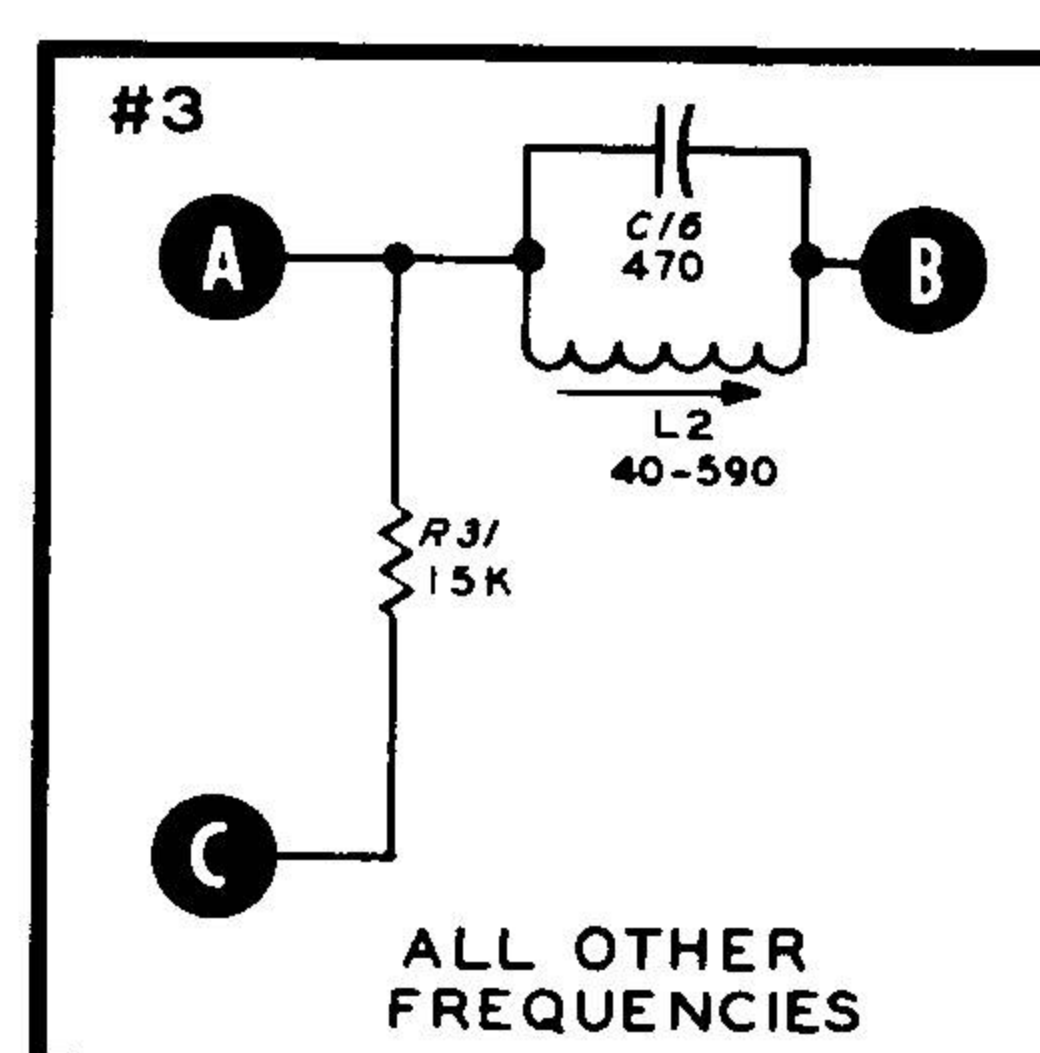
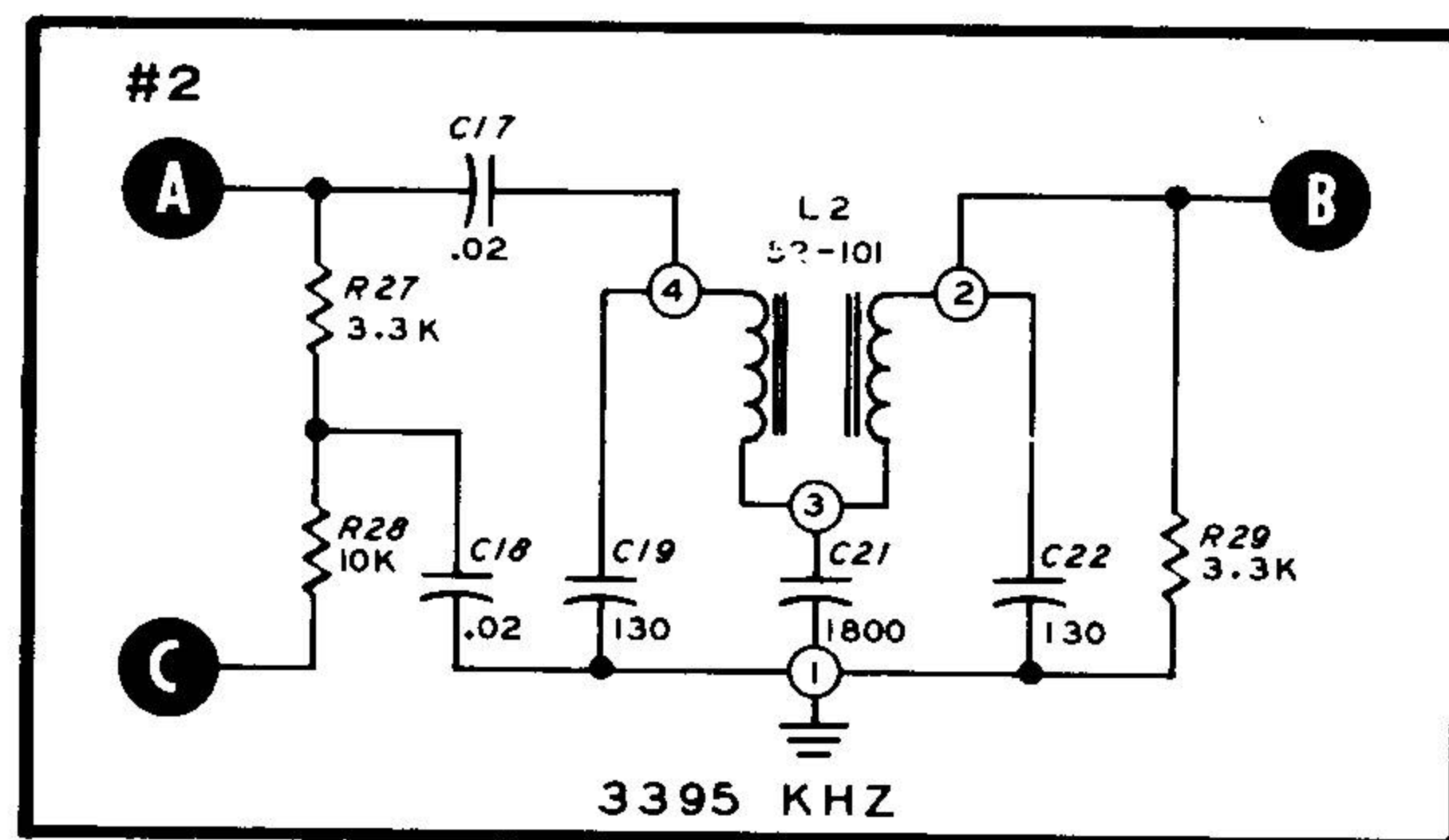
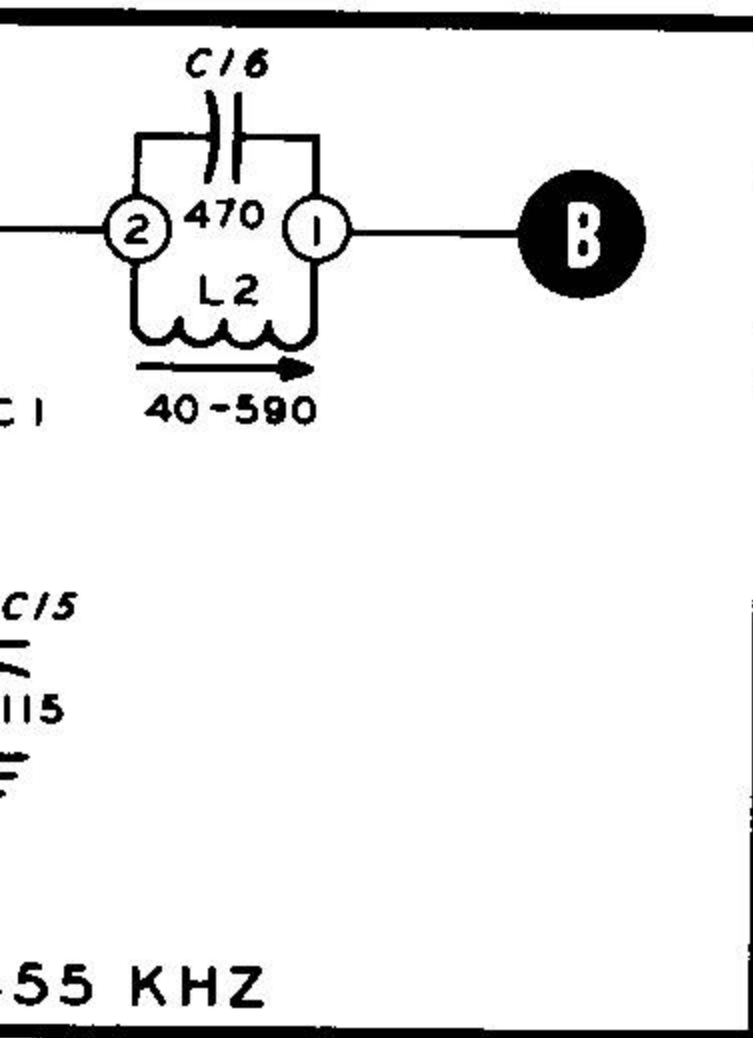

SCHEMATIC OF HEATHKIT SCANALYZER MODEL SB-6

NOTES:

- SEE IF CHART ON PAGE 75.
- A. NO CAPACITOR USED ACROSS
- B. WHEN WIRED FOR A RECEIVER
- WHEN OSCILLATOR COIL 40-775 IS
- CAPACITOR VALUES LESS THAN 1 UNLESS OTHERWISE MARKED.
- ALL RESISTORS ARE 1/2 WATT UNLESS OTHERWISE MARKED IN OHMS (K = 1000, M = 1,000,000).
- SWITCH WAFERS ARE SHOWN IN FULL POSITION FROM THE REAR. ARROWS SHOW DIRECTION.
- NE-83-A, VOLTAGE REGULATOR, 100V-0-100V

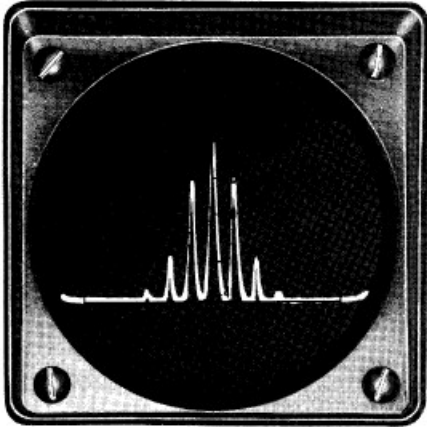

Figure 40-9

Same amplitude modulated signal as shown in Figure 40-7, except amplitude scale is now in the Log position. Observe the pip amplitude of the second harmonic of the modulating audio tone when shown on a logarithmic scale.

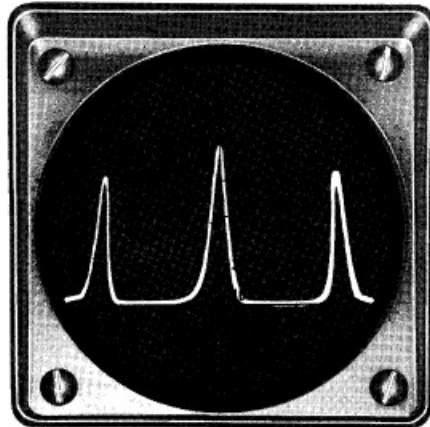

Figure 40-10

Same as Figure 40-8, except amplitude scale set at the Log position.

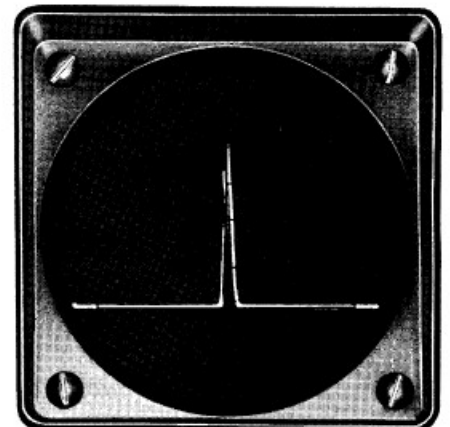

Figure 40-11

Two equal amplitude interfering carriers 1 kHz apart. Sweep Width: 50 kHz. Amplitude scale: Linear.

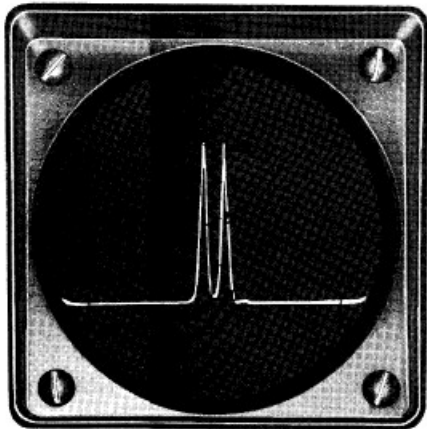

Figure 40-12

Same two carriers as shown in Figure 40-11, except the Sweep Width is now 10 kHz. Observe the improved resolution.

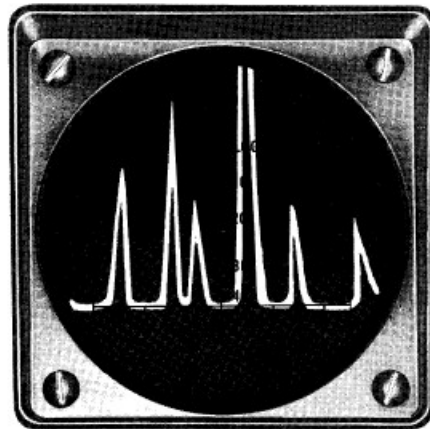

Figure 40-13

Distribution of signals of various amplitudes. Sweep Width: 500 kHz. Amplitude Scale: Linear.

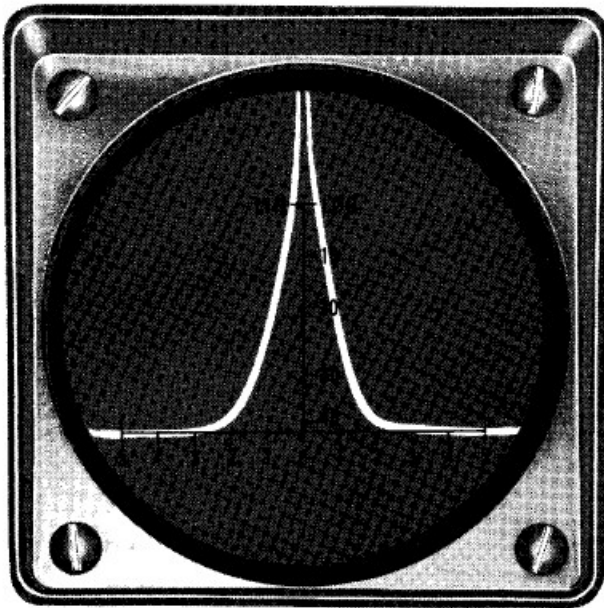

Figure 40-3

A constant carrier signal was set to 0 dB with the Amplitude Scale switch set at the -20 dB LOG position. Then the Amplitude Scale switch was set to the LOG position. This shows the 20 dB to 60 dB area of the pip. Sweep Width: 10 KHz, Amplitude Scale: LOG.

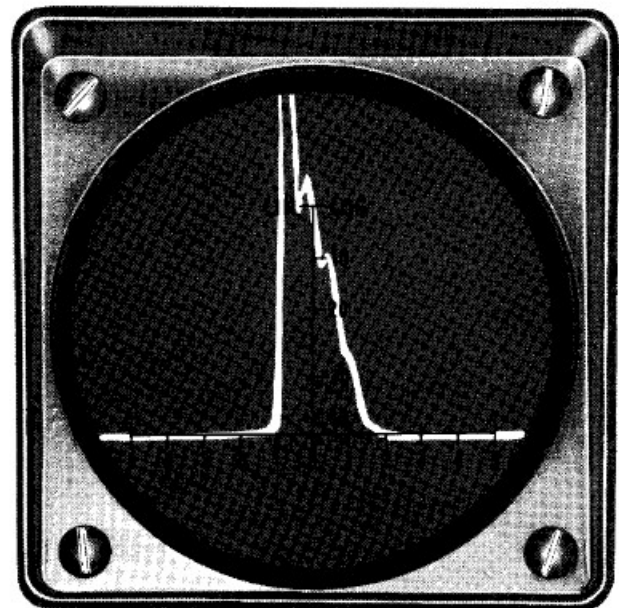

Figure 40-4

The same constant carrier signal as shown in Figure 40-3, except with severe ringing on the pip.

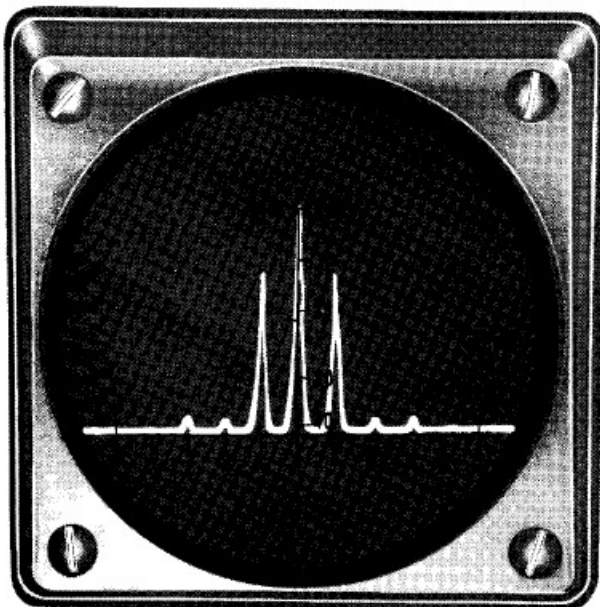

Figure 40-7

Same amplitude modulated signal as shown in Figure 40-6, except Sweep Width is now set at 50 kHz. The two pairs of small pips at the 20 kHz and 30 kHz markings are harmonics of the modulating audio tone.

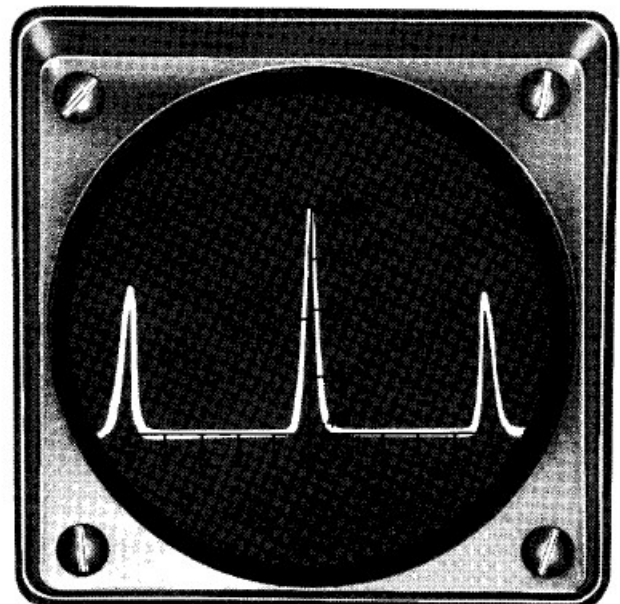

Figure 40-8

Same amplitude modulated signal as shown in Figure 40-6, except Sweep Width is now set at 10 kHz position.

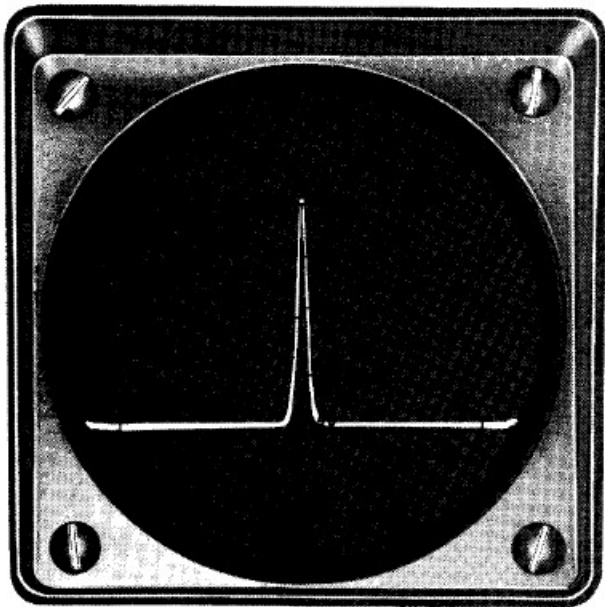

Figure 40-1

Constant carrier signal, Sweep Width: 100 kHz, Amplitude Scale: Linear.

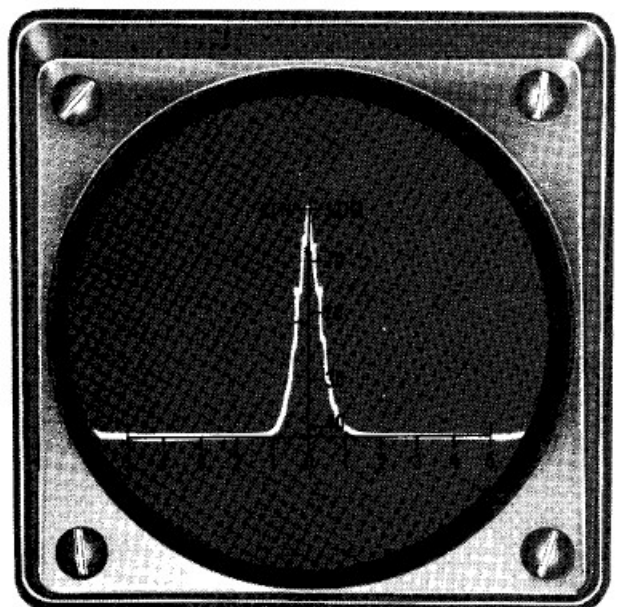

Figure 40-2

Constant Carrier signal with 60 Hz hum. Observe the ripple effect along the sides of the pip. Sweep Width: 10 kHz, Amplitude Scale: Linear.

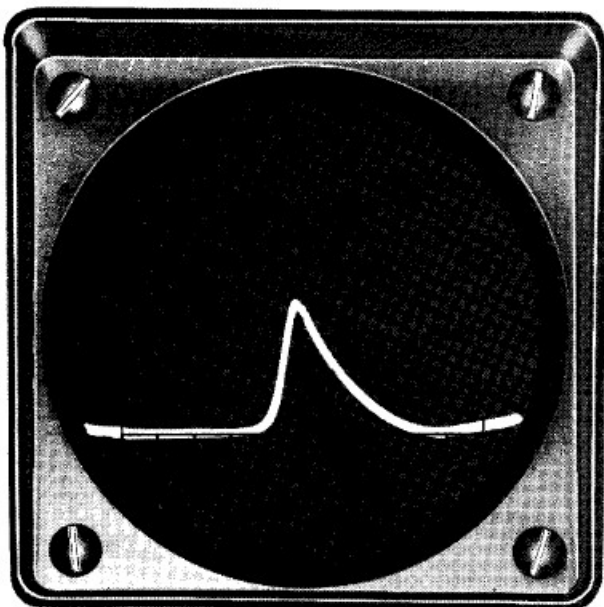

Figure 40-5

Constant carrier signal with the Horiz Pos control pushed in for Fast Sweep. Sweep Width: 10 kHz, Amplitude Scale: Log.

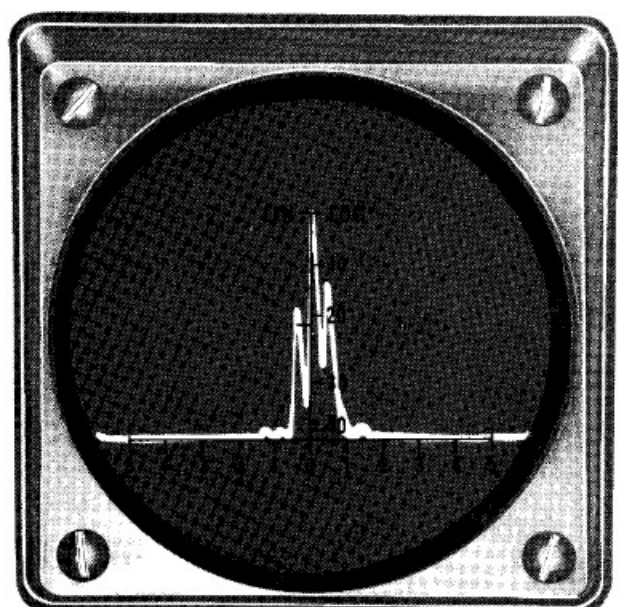

Figure 40-6

Amplitude modulated signal showing carrier and two sidebands. Modulating audio tone: 5 kHz, Sweep Width = 100 kHz, Amplitude Scale: Linear.