

# HP Archive

This vintage Hewlett Packard document was  
preserved and distributed by

**[www. hparchive.com](http://www.hparchive.com)**

Please visit us on the web !

Scanned by on-line curator: Tony Gerbic

**\*\* For FREE Distribution Only \*\*\***

**410C**  
**ELECTRONIC**  
**VOLTMETER**

**OPERATING AND SERVICE MANUAL**

---

HEWLETT  PACKARD

---

HP 410C



**OPERATING AND SERVICE MANUAL**

(HP PART NO. 00410-90005)

**MODEL 410C  
ELECTRONIC VOLTMETER**

**SERIALS PREFIXED: 807-**

Appendix C, Manual Backdating  
Changes adapts this manual to  
Serials Prefixed:

311, 328, 339, 433, 532, and 550

Copyright Hewlett-Packard Company 1963  
P.O. Box 301, Loveland, Colorado, 80537 U.S.A.

## TABLE OF CONTENTS

Section	Page	Section	Page
I GENERAL INFORMATION . . . . .	1-3	V MAINTENANCE . . . . .	5-1
1-1. Description . . . . .	1-3	5-1. Introduction . . . . .	5-1
1-4. Instrument Identification . . . . .	1-3	5-3. Test Equipment Required . . . . .	5-1
1-6. Accessories Available . . . . .	1-3	5-5. Performance Checks . . . . .	5-1
Section	Page	5-7. Alternate Calibration Voltage Source . . . . .	5-1
II INSTALLATION . . . . .	2-1	5-9. Mechanical Meter Zero . . . . .	5-1
2-1. Inspection . . . . .	2-1	5-10. DC Voltmeter Operation . . . . .	5-1
2-3. Installation . . . . .	2-1	5-13. DC Ammeter Operation . . . . .	5-2
2-5. Rack Mounting . . . . .	2-1	5-15. Ohmmeter Operation . . . . .	5-2
2-9. Three-Conductor Power Cable . . . . .	2-1	5-17. Amplifier Operation . . . . .	5-3
2-12. Primary Power Requirements . . . . .	2-1	5-24. AC Voltmeter Operation . . . . .	5-4
2-14. Repackaging for Shipment . . . . .	2-2	5-28. Adjustment and Calibration Proce- dure . . . . .	5-6
Section	Page	5-31. Chopper Frequency Adjust . . . . .	5-6
III OPERATION . . . . .	3-1	5-32. Power Supply Check . . . . .	5-8
3-1. Introduction . . . . .	3-1	5-33. DC Voltmeter Calibration . . . . .	5-8
3-3. Adjustment of Mechanical Zero . . . . .	3-1	5-36. Ohmmeter Calibration . . . . .	5-8
3-5. Front and Rear Panel Description . . . . .	3-1	5-37. Amplifier Output Calibration . . . . .	5-8
3-7. Operating Procedures . . . . .	3-1	5-38. AC Voltmeter Calibration . . . . .	5-9
3-9. DC Voltage Measurements . . . . .	3-1	5-41. Troubleshooting Procedure . . . . .	5-9
3-11. DC Current Measurements . . . . .	3-1	5-48. Servicing Etched Circuit Boards . . . . .	5-9
3-13. AC Voltage Measurements . . . . .	3-1	Section	Page
3-15. Precautions when Measuring AC Voltage . . . . .	3-1	VI REPLACEABLE PARTS . . . . .	6-1
3-28. Negative Pulses . . . . .	3-4	6-1. Introduction . . . . .	6-1
3-31. Measuring Resistance . . . . .	3-4	6-4. Ordering Information . . . . .	6-1
3-33. Measuring DC Nano-Ampere Cur- rent . . . . .	3-4	6-6. Non-Listed Parts . . . . .	6-1
Section	Page	Appendix	
IV THEORY OF OPERATION . . . . .	4-1	A CODE LIST OF MANUFACTURERS	
4-1. Overall Description . . . . .	4-1	Appendix	
4-4. Circuit Description . . . . .	4-1	B SALES AND SERVICE OFFICES	
4-5. Input Network . . . . .	4-1	Appendix	
4-16. Modulator-Demodulator . . . . .	4-1	C MANUAL BACKDATING CHANGES	
4-23. The Feedback Network . . . . .	4-2		
4-27. Power Supply . . . . .	4-2		

## LIST OF TABLES

Number	Page	Number	Page
1-1. Specifications . . . . .	1-2	5-5. AC Accuracy Test . . . . .	5-4
3-1. Possible Error when Measuring Voltage of Complex Waveforms . . . . .	3-3	5-6. Power Supply Test . . . . .	5-8
5-1. Recommended Test Equipment . . . . .	5-0	5-7. DCV Calibration Procedure . . . . .	5-8
5-2. DCV Accuracy Test . . . . .	5-2	5-8. AC Full Scale Adjust . . . . .	5-9
5-3. DCV Input Resistance Test . . . . .	5-2	5-9. Front Panel Troubleshooting Procedure . . . . .	5-10
5-4. DCA Accuracy Test . . . . .	5-3	6-1. Reference Designation Index . . . . .	6-2
		6-2. Replaceable Parts . . . . .	6-7
		6-3. Replaceable Hardware . . . . .	6-10

## LIST OF ILLUSTRATIONS

Number	Page	Number	Page
1-1. The $\text{E}$ Model 410C Electronic Voltmeter . . . . .	1-1	4-4. Simplified Schematic, DC Voltage Measurements . . . . .	4-4
2-1. The Combining Case . . . . .	2-0	4-5. Simplified Schematic, Resistance Measurement . . . . .	4-5
2-2. Steps to Place Instrument in Combining Case . . . . .	2-0	4-6. Simplified Schematic, AC Voltage Measurement . . . . .	4-6
2-3. Adaptor Frame Instrument Combination . . . . .	2-1	5-1. Alternate Calibration Voltage Source . . . . .	5-1
2-4. Two Half Modules in Rack Adaptor . . . . .	2-2	5-2. DC Ammeter Operation . . . . .	5-3
3-1. Front and Rear Panel Controls . . . . .	3-2	5-3. Low Frequency Response Test . . . . .	5-5
3-2. DC Voltage Measurements . . . . .	3-5	5-4. High Frequency Response Test . . . . .	5-6
3-3. DC Current Measurements . . . . .	3-6	5-5. Adjustment Location . . . . .	5-7
3-4. AC Voltage Measurements . . . . .	3-7	5-6. Chopper Frequency Adjust Setup . . . . .	5-7
3-5. Maximum AC Voltage Chart for 11036A Probe . . . . .	3-8	5-7. Troubleshooting Procedures . . . . .	5-11/5-12
3-6. Graph Used in Calculation of Pulse Voltage Readings . . . . .	3-9	5-8. Power Supply Measurements . . . . .	5-11/5-12
3-7. Resistance Measurements . . . . .	3-10	5-9. Power Supply Schematic . . . . .	5-11/5-12
3-8. DC Nano-Ampere Current Measurements . . . . .	3-11	5-10. Typical Amplifier Waveforms . . . . .	5-13/5-14
4-1. Block Diagram, Model 410C . . . . .	4-0	5-11. Amplifier Schematic . . . . .	5-13/5-14
4-2. Modulator-Demodulator Mechanical Analogy . . . . .	4-0	5-12. Model 11036A AC Probe (Exploded View) . . . . .	5-14
4-3. Simplified Schematic, DC Current Measurement . . . . .	4-3	5-13. Model 11036A AC Probe Schematic . . . . .	5-14
		5-14. RANGE and FUNCTION Switching (Pictorial) . . . . .	5-15
		5-15. Input RANGE and FUNCTION Switching Schematic . . . . .	5-16

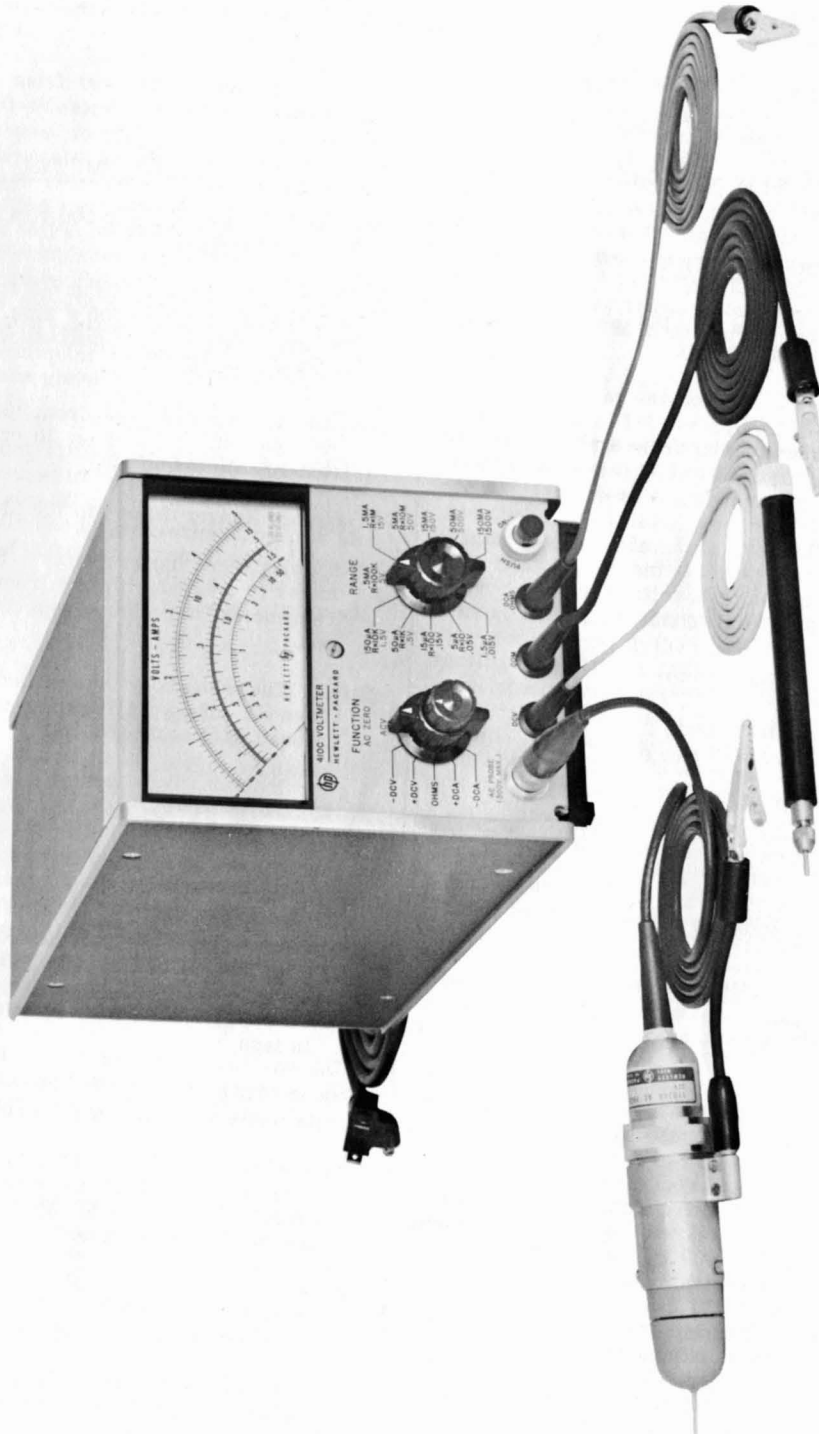

Figure 1-1. The Model 410C Electronic Voltmeter

Table 1-1. Specifications

<u>DC VOLTMETER</u>	<u>AMPLIFIER (Cont'd)</u>
<p>Voltage Ranges: <math>\pm 15</math> mv to <math>\pm 1500</math> v full scale in 15, 50 sequence (11 ranges).</p> <p>Accuracy: <math>\pm 2\%</math> of full scale on any range.</p> <p>Input Resistance: 100 megohms <math>\pm 1\%</math> on 500 mv range and above. 10 megohms <math>\pm 3\%</math> on 15 mv, 50 mv, and 150 mv ranges.</p>	<p>DC Drift: Less than 0.5% of full scale/year at constant temperature. Less than 0.02% of full scale /<math>^{\circ}</math>C.</p> <p>Overload Recovery: Recover from 100:1 overload in &lt;3 sec.</p>
<u>DC AMMETER</u>	<u>AC VOLTMETER</u>
<p>Current Ranges: <math>\pm 1.5</math> <math>\mu</math>a to <math>\pm 150</math> ma full scale in 1.5, 5 sequence (11 ranges).</p> <p>Accuracy: <math>\pm 3\%</math> of full scale on any range.</p> <p>Input Resistance: Decreasing from 9 Kohms on 1.5 <math>\mu</math>a scale to approximately 0.3 <math>\Omega</math> on the 150 ma scale.</p> <p>Special Current Ranges: <math>\pm 1.5</math>, <math>\pm 5</math>, and <math>\pm 15</math> nanoamps may be measured on the 15, 50, and 150 millivolt ranges using the voltmeter probe, with <math>\pm 5\%</math> accuracy and 10 megohm input resistance.</p>	<p>Ranges: 0.5 v full scale to 300 v in 0.5, 1.5, 5 sequence (7 ranges).</p> <p>Accuracy: <math>\pm 3\%</math> of full scale at 400 cps for sinusoidal voltages from 0.5 to 300 v rms. The AC Probe responds to the positive peak-above-average value of the applied signal.</p> <p>Frequency Response: <math>\pm 2\%</math> from 100 cps to 100 Mc (400 cps ref.) <math>\pm 10\%</math> from 20 cps to 100 cps and from 100 Mc to 700 Mc.</p> <p>Frequency Range: 20 cps to 700 Mc.</p> <p>Input Impedance: Input capacity 1.5 pf, input resistance &gt;10 megohms at low frequencies. At high frequencies impedance drops off due to dielectric loss.</p>
<u>OHMMETER</u>	<p>Safety: The probe body is grounded to chassis at all times for safety. All ac measurements are referenced to chassis ground.</p> <p>Meter: Individually calibrated taut band meter. Responds to positive peak-above-average. Calibrated in rms volts for sine wave input.</p>
<p>Resistance Range: Resistance from 10 ohms to 10 megohm center scale (7 ranges).</p> <p>Accuracy: Zero to midscale; <math>\pm 5\%</math> of reading or <math>\pm 2\%</math> of midscale, whichever is greater. <math>\pm 7\%</math> from midscale to scale value of 2. <math>\pm 8\%</math> from scale value of 2 to 3. <math>\pm 9\%</math> from scale value of 3 to 5. <math>\pm 10\%</math> from scale value of 5 to 10.</p>	<u>GENERAL</u>
<u>AMPLIFIER</u>	<p>Maximum Input: (see Overload Recovery) DC: 100 v on 15, 50, and 150 mv ranges; 500 v on 0.5 to 15 v ranges; 1600 v on higher ranges. AC: 100 times full scale or 450 v peak, whichever is less.</p> <p>Power: 115 or 230 v <math>\pm 10\%</math>. 50 to 1000 cps, 13 watts (20 watts with 11036A AC Probe).</p> <p>Dimensions: 6-1/2 in. high (16.5 cm); 5-1/8 in. wide (13.01 cm); 11 in. deep (27.9 cm) behind panel. Fits 5060-0797 Rack Adapter and 1050 series combining cases.</p> <p>Weight: Net: 8 lbs. (4.0 kg). Shipping: approximately 14 lbs. (6.35 kg).</p> <p>Accessories Furnished: Detachable power cord, NEMA plug; <math>\Phi</math> Model 11036A AC Probe.</p> <p>Option 02: <math>\Phi</math> Model 410C less AC Probe.</p>

## SECTION I

### GENERAL INFORMATION

#### 1-1. DESCRIPTION.

1-2. The Hewlett-Packard Model 410C Electronic Voltmeter can be used to measure dc voltage and dc current; ac voltage and resistance. Positive and negative dc voltages from 15 millivolts to 1500 volts full scale and positive and negative dc currents from 1.5 microamperes to 150 milliamperes can be measured full scale. Resistance from 10 ohms to 10 megohms mid-scale can be measured with an accuracy of  $\pm 5\%$ ; resistance from 0.2 ohms to 500 megohms can be measured with reduced accuracy. The Model 410C Electronic Voltmeter is shown in Figure 1-1; the specifications are given in Table 1-1.

1-3. With the Model 11036A detachable AC Probe, the Voltmeter can be used to measure AC voltage from 20 cps to 700 Mc. From 20 cps to 100 Mc, AC voltage from 0.5 to 300 volts can be measured; from 100 Mc to 700 Mc, refer to Figure 3-5 for maximum AC voltage that can be applied to the AC Probe. For additional information on the AC Probe, refer to Paragraph 1-8.

#### 1-4. INSTRUMENT IDENTIFICATION.

1-5. Hewlett-Packard uses a two section, eight-digit serial number (000-00000). The serial number is on a plate attached to the rear panel of the instrument. If the first three digits of the serial number on your instrument do not agree with those on the title page of this manual, Appendix C, Backdating Changes will define differences between your instrument and the Model 410C described in this manual.

#### 1-6. ACCESSORIES AVAILABLE.

1-7. Accessories are available that extend the AC and DC measuring capabilities of the Voltmeter. A description of these accessories and their specifications is given below.

1-8. MODEL 11036A AC PROBE. This accessory, when used with the Model 410C, permits AC voltage measurements from 0.5 volts rms to 300 volts rms, full scale over a frequency range of 20 cps to 700 Mc. Reference calibration accuracy at 400 cps (sinusoidal) is  $\pm 3\%$  of full scale. Frequency response is  $\pm 10\%$  from 20 cps to 700 Mc, with indications obtainable to 3000 Mc. Frequency response at 100 Mc is within  $\pm 2\%$ . The Model 11036A responds to the positive-peak-above-average value of the signal applied. The Model 410C is calibrated to read in RMS volts, for sine wave inputs.

1-9. MODEL 11039A CAPACITIVE VOLTAGE DIVIDER. This accessory (formerly the Model 452A) extends the AC voltage range of the Model 410C to 25 kv. The divider permits measurements of extremely high AC voltage such as encountered in dielectric heating equipment, etc., over a frequency range of 25 cps to 20 Mc. A fixed gap is provided so that breakdown will occur if the applied voltage exceeds 28 kv at low frequencies. Voltage division is 1000:1,  $\pm 3\%$ , and input capacity is 15 picofarads. A Model 11018A Adapter is also required to connect the Model 11036A AC Probe to the shielded banana plug fitting of the divider.

1-10. MODEL 11040A CAPACITY DIVIDER. This accessory (formerly the Model 453A) extends the AC voltage range of the Voltmeter to 2000 volts RMS. The divider is for use at frequencies above 10 kc. Voltage division is 100:1,  $\pm 1\%$ , and input capacity is approximately 2 picofarads.

1-11. MODEL 11042A PROBE T CONNECTOR. This accessory (formerly the Model 455A) is used for connecting the Model 11036A Probe across a 50-ohm transmission line using type N connectors. The T-joint is such that connection of the probe into a transmission line will not cause a standing wave ratio greater than 1.1 at 500 Mc and 1.2 at 1000 Mc. With this device, measurement of power traveling through a transmission line may be made with reasonable accuracy to 1000 Mc. The usual precautions must be taken to provide accurate impedance matching and the elimination of standing waves along the line through which power is floating. By using a dummy load at the receiving end of this T-joint, power output of various devices can be measured. In many applications power going into a real load, such as an antenna, can be conveniently measured up to 1000 Mc with good accuracy.

1-12. MODEL 11043A TYPE N CONNECTOR. This accessory (formerly the Model 458A) allows the AC Probe to be connected to a 50-ohm coaxial line. The connector uses a male type N connector and a receptacle for receiving the probe. Terminating resistor is not included.

1-13. MODEL 11045A DC DIVIDER. This accessory extends the maximum DC voltage range of the Model 410C to 30 kv. Voltage division is 100:1,  $\pm 5\%$ , and input resistance is 9900 megohms. When used with the Model 410C, input resistance is 10,000 megohms. This probe offers maximum safety and convenience for measuring high voltages such as in television equipment, etc. The maximum current drain is 2.5 microamperes.



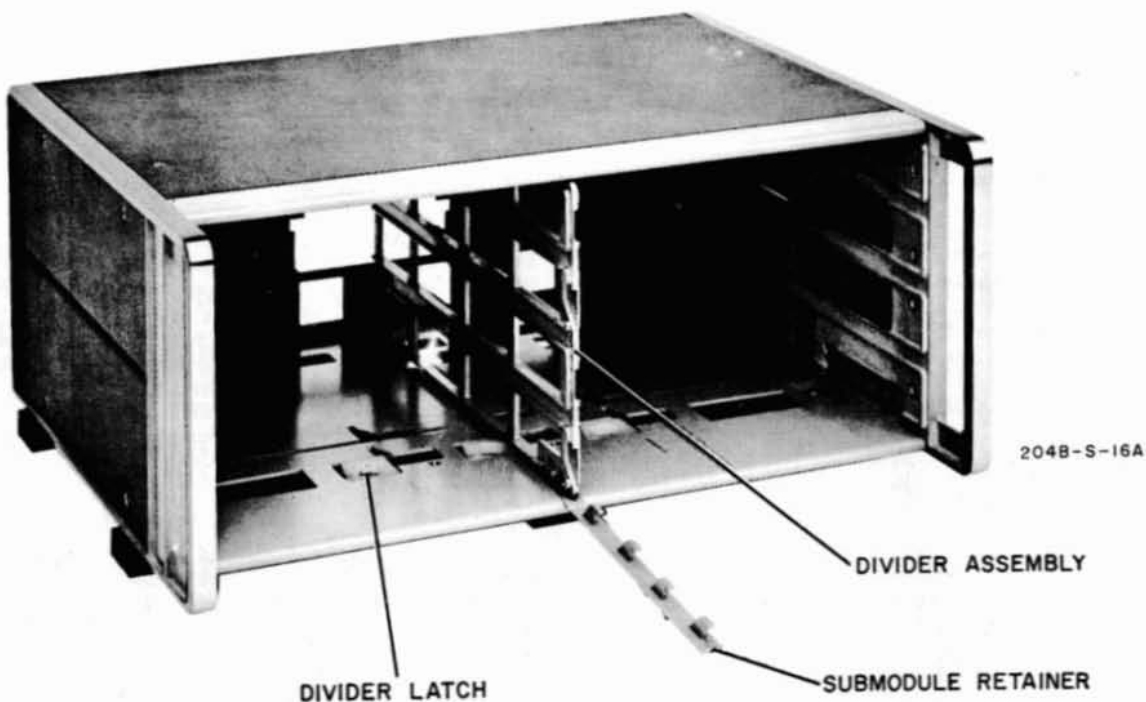

Figure 2-1. The Combining Case

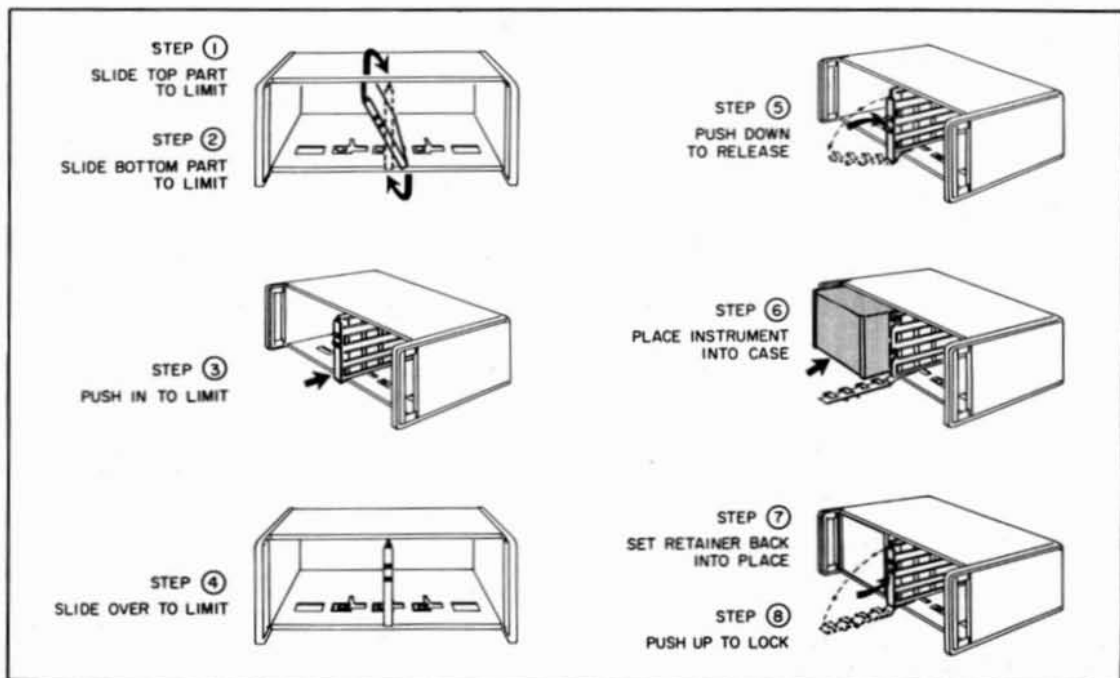

Figure 2-2. Steps to Place Instrument in Combining Case

## SECTION II INSTALLATION

### 2-1. INSPECTION.

2-2. This instrument was carefully inspected both mechanically and electrically, before shipment. It should be physically free of marks or scratches and in perfect electrical order upon receipt. To confirm this, the instrument should be inspected for physical damage in transit. Also, check for supplied accessories, and test the electrical performance of the instrument using the procedure outlined in Paragraph 5-5, Performance Checks. If there is damage or deficiency, see the warranty on the inside front cover of this manual.

### 2-3. INSTALLATION.

2-4. The Model 410C is transistorized except for one vacuum tube and requires no special cooling. However, the instrument should not be operated where the ambient temperature exceeds 55° C (140° F).

### 2-5. RACK MOUNTING.

2-6. The Model 410C is a submodular unit designed for bench use. However, when used in combination with other submodular units, it can be bench and/or rack mounted. The Combining Cases and Adapter Frame are designed specifically for this purpose.

2-7. MODELS 1051A AND 1052A COMBINING CASES. The Combining Cases are full-module units which accept various combinations of submodular units. Being a full width unit, it can either be bench or rack mounted. An illustration of the Combining Case is shown in Figure 2-1. Instructions for installing the Model 410C are shown in Figure 2-2.

2-8. RACK ADAPTER FRAME (Part No. 5060-0797). The adapter frame is a rack mounting frame that accepts various combinations of submodular units. It can be rack mounted only. An illustration of the adapter frame is given in Figure 2-3. Instructions are given below.

a. Place the adapter frame on edge of bench as shown in step 1, Figure 2-4.

b. Stack the submodular units in the frame as shown in step 2, Figure 2-4. Place the spacer clamps between instruments as shown in step 3, Figure 2-4.

c. Place spacer clamps on the two end instruments (see step 4, Figure 2-4) and push the combination into the frame.

d. Insert screws on either side of frame, and tighten until submodular instruments are tight in the frame.

e. The complete assembly is ready for rack mounting.

### 2-9. THREE-CONDUCTOR POWER CABLE.

2-10. To protect operating personnel, the National Electrical Manufacturers' Association (NEMA) recommends that the instrument panel and cabinet be grounded. All Hewlett-Packard instruments are equipped with a three-conductor power cable which grounds the instrument when plugged into an appropriate receptacle.

2-11. To preserve the protection feature when operating the instrument from a two-contact outlet, use three-prong to two-prong adapter and connect the green pigtail on the adapter to ground.

### 2-12. PRIMARY POWER REQUIREMENTS.

2-13. The Model 410C can be operated from either 115 or 230 volts, 50 to 1000 cps. The instrument can be easily converted from 115- to 230- volt operation. The LINE VOLTAGE switch, S4 a two-position slide switch located at the rear of the instrument, selects the mode of AC operation. The line voltage from which the instrument is set to operate appears on the slider of the switch. A 0.25-ampere, slo-blo fuse is used for both 115- and 230-volt operation. If the Model 410C is operated at any frequency other than 60 cps, perform chopper frequency adjust (Paragraph 5-31).

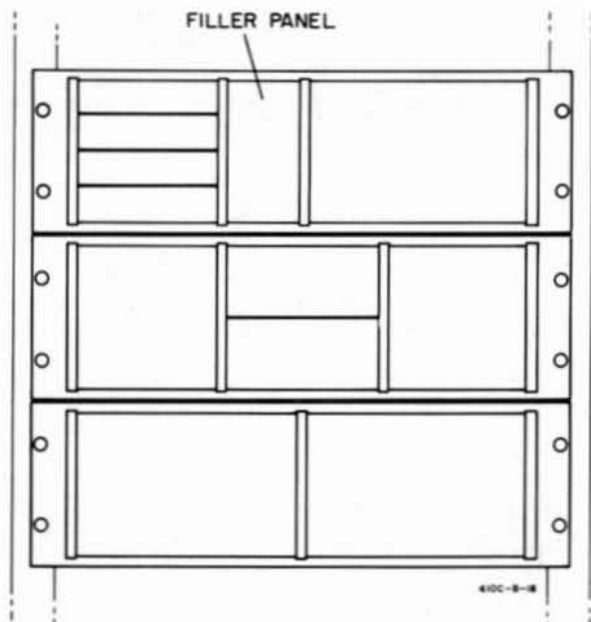

Figure 2-3. Adapter Frame Instrument Combination

**CAUTION**

DO NOT CHANGE THE SETTING OF THE LINE VOLTAGE SWITCH WHEN THE VOLT-METER IS OPERATING.

**2-14. REPACKAGING FOR SHIPMENT.**

2-15. The following paragraphs contain a general guide for repackaging of the instrument for shipment. Refer to Paragraph 2-16 if the original container is to be used; 2-17 if it is not. If you have any questions, contact your local Sales and Service Office. (See Appendix B for office locations.)

**NOTE**

If the instrument is to be shipped to Hewlett-Packard for service or repair, attach a tag to the instrument identifying the owner and indicate the service or repair to be performed; include the model number and full serial number of the instrument. In any correspondence, identify the instrument by model number, serial number and serial number prefix.

2-16. If the original container is to be used, proceed as follows:

a. Place instrument in original container if available. If original container is not available, one can be purchased from your nearest Sales and Service Office.

b. Ensure that container is well sealed with strong tape or metal bands.

2-17. If original container is not to be used, proceed as follows:

a. Wrap instrument in heavy paper or plastic before placing in an inner container.

b. Place packing material around all sides of instrument and protect panel face with cardboard strips.

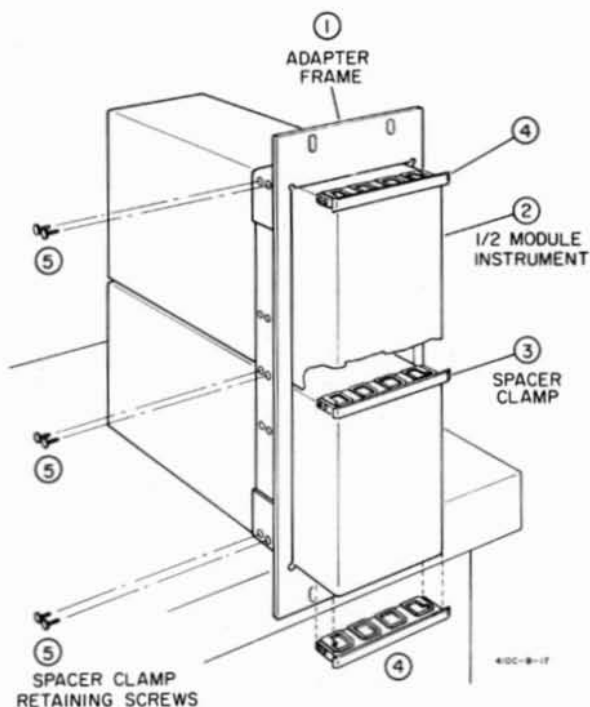

Figure 2-4. Two Half Modules in Rack Adapter

c. Place instrument and inner container in a heavy carton or wooden box and seal with strong tape or metal bands.

d. Mark shipping container with "DELICATE INSTRUMENT", "FRAGILE", etc.

## SECTION III

### OPERATION

#### 3-1. INTRODUCTION.

3-2. The Model 410C is used to measure AC and DC voltage, DC current, and resistance. All measurement inputs are located on the front panel; a DC output connector is located on the rear panel. Front panel controls and indicators are color coded. DC voltage, DC current and resistance knobs and indicators are in black; AC voltage controls and indicators are in red.

#### 3-3. ADJUSTMENT OF MECHANICAL ZERO.

3-4. The procedure for adjustment of mechanical zero is given in Section V.

#### 3-5. FRONT AND REAR PANEL DESCRIPTION.

3-6. Figure 3-1 describes the function of all front and rear panel controls, connectors and indicators. The description of each control, connector and indicator is keyed to a drawing which accompanies the figure.

#### 3-7. OPERATING PROCEDURES.

3-8. There are five operating procedures: DC Voltage Measurements, Figure 3-2; DC Current Measurements, Figure 3-3; AC Voltage Measurements, Figure 3-4; Resistance Measurements, Figure 3-7; and Measuring DC Current in Nano-amperes, Figure 3-8.

#### Note

Ageing of the neon lamps in the chopper assembly can cause a change in chopper frequency which produces a slight oscillatory movement of meter pointer. If this oscillatory movement is observed, rotate Osc Freq Adj A3R5 (see Paragraph 5-31) in the ccw direction until oscillation of pointer stops.

#### 3-9. DC VOLTAGE MEASUREMENTS (Figure 3-2).

3-10. The Model 410C is normally floating; however a shorting bar can be connected at the DC AMPLIFIER OUTPUT connector on the rear panel. When the instrument is floating, the COM Lead should not be connected to voltages greater than 400 VDC.

#### 3-11. DC CURRENT MEASUREMENTS (Figure 3-3).

3-12. General instructions for the measurement of DC current are the same as those given for DC voltage measurements, Paragraph 3-9.

#### 3-13. AC VOLTAGE MEASUREMENTS (Figure 3-4).



ONE SIDE OF ALMOST ALL POWER DISTRIBUTION SYSTEMS IS GROUNDED. EXTREME CAUTION MUST BE USED IF DIRECT MEASUREMENT OF POWER LINE VOLTAGES IS ATTEMPTED. IF THE GROUND CLIP LEAD IS ACCIDENTALLY CONNECTED TO THE UN-GROUNDED SIDE OF THE LINE SEVERE DAMAGE TO THE 410C IS POSSIBLE BECAUSE OF THE SHORT CIRCUIT CREATED. POWER LINE VOLTAGES CAN BE SAFELY MEASURED BY USING THE PROBE TIP ONLY. CONTACTING THE GROUNDED POWER CONDUCTOR WILL GIVE A READING OF 0 VOLTS WHILE CONTACTING THE UN-GROUNDED LEAD WILL GIVE FULL VOLTAGE READING.

3-14. Although the Model 410C indicates a full scale AC range of 500 volts, the optional Model 11036A AC Probe should not be connected to AC voltages in excess of 300 volts RMS. AC voltage referenced to a DC voltage may be measured, but the AC Probe clip (alligator type) must be connected to the ground ( $\perp$ ) of the circuit under test.



WHEN MEASURING AC REFERENCED TO DC, THE PEAK AC VOLTAGE PLUS DC VOLTAGE CONNECTED TO THE PROBE MUST NOT EXCEED 420 VOLTS.

#### 3-15. PRECAUTIONS WHEN MEASURING AC VOLTAGE.

3-16. Special considerations must be kept in mind when making AC voltage measurements. These considerations are discussed in the following paragraphs.

3-17. GENERAL CONSIDERATION OF COMPLEX WAVEFORMS. Waveforms containing appreciable harmonics or spurious voltages will introduce error in the meter indication since the meter has been calibrated to read RMS values of true sine waves while the Model 11036A Probe is a peak-above-average responding device. The magnitude of error that may be expected when harmonics are present on the measured waveform is indicated in Table 3-1.

3-18. VOLTAGE MEASUREMENTS AT FREQUENCIES BELOW 50 CYCLES/SECOND. Voltage measurements at frequencies as low as 20 cycles per

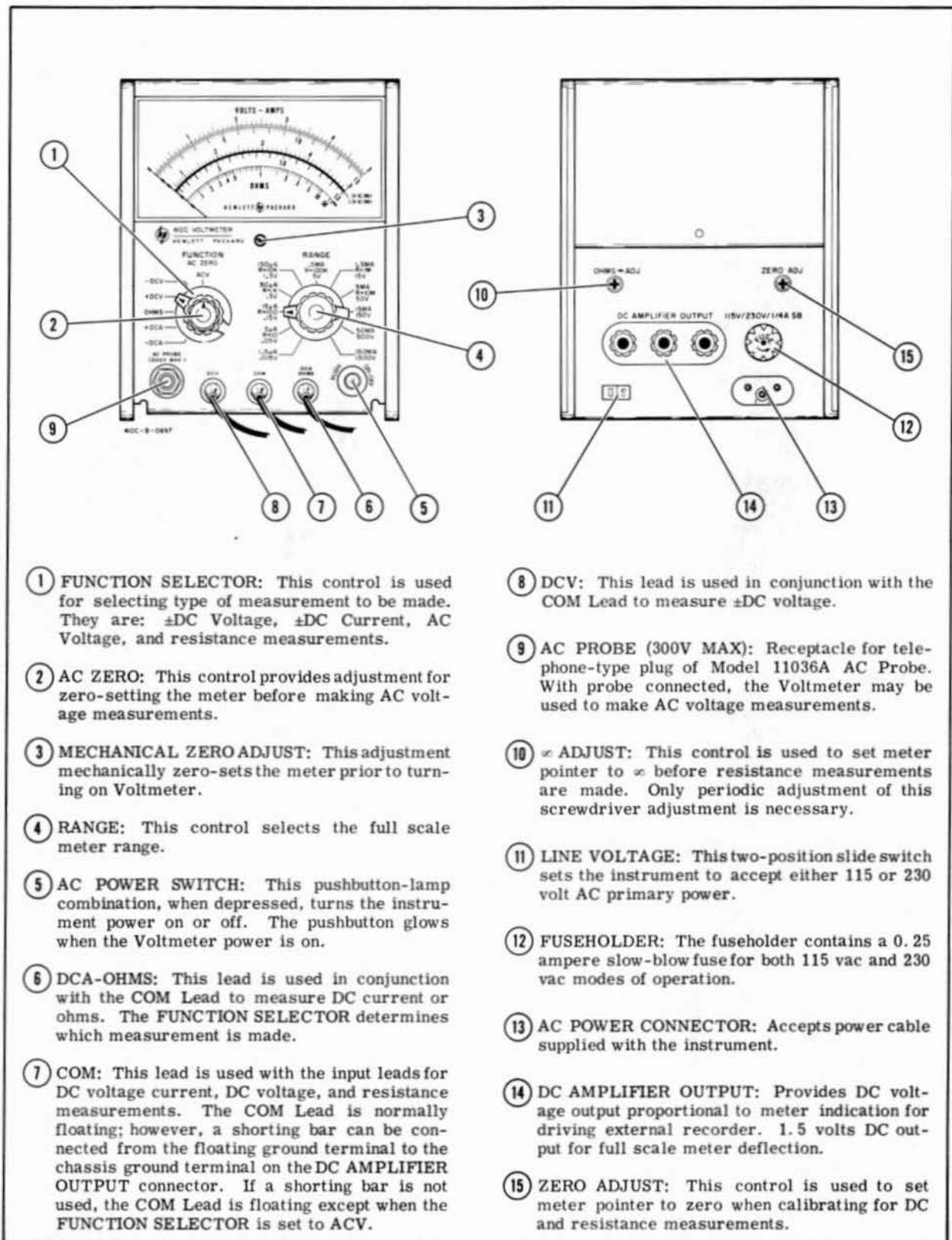

- ① **FUNCTION SELECTOR:** This control is used for selecting type of measurement to be made. They are:  $\pm$ DC Voltage,  $\pm$ DC Current, AC Voltage, and resistance measurements.
- ② **AC ZERO:** This control provides adjustment for zero-setting the meter before making AC voltage measurements.
- ③ **MECHANICAL ZERO ADJUST:** This adjustment mechanically zero-sets the meter prior to turning on Voltmeter.
- ④ **RANGE:** This control selects the full scale meter range.
- ⑤ **AC POWER SWITCH:** This pushbutton-lamp combination, when depressed, turns the instrument power on or off. The pushbutton glows when the Voltmeter power is on.
- ⑥ **DCA-OHMS:** This lead is used in conjunction with the COM Lead to measure DC current or ohms. The FUNCTION SELECTOR determines which measurement is made.
- ⑦ **COM:** This lead is used with the input leads for DC voltage current, DC voltage, and resistance measurements. The COM Lead is normally floating; however, a shorting bar can be connected from the floating ground terminal to the chassis ground terminal on the DC AMPLIFIER OUTPUT connector. If a shorting bar is not used, the COM Lead is floating except when the FUNCTION SELECTOR is set to ACV.
- ⑧ **DCV:** This lead is used in conjunction with the COM Lead to measure  $\pm$ DC voltage.
- ⑨ **AC PROBE (300V MAX):** Receptacle for telephone-type plug of Model 11036A AC Probe. With probe connected, the Voltmeter may be used to make AC voltage measurements.
- ⑩  **$\infty$  ADJUST:** This control is used to set meter pointer to  $\infty$  before resistance measurements are made. Only periodic adjustment of this screwdriver adjustment is necessary.
- ⑪ **LINE VOLTAGE:** This two-position slide switch sets the instrument to accept either 115 or 230 volt AC primary power.
- ⑫ **FUSEHOLDER:** The fuseholder contains a 0.25 ampere slow-blow fuse for both 115 vac and 230 vac modes of operation.
- ⑬ **AC POWER CONNECTOR:** Accepts power cable supplied with the instrument.
- ⑭ **DC AMPLIFIER OUTPUT:** Provides DC voltage output proportional to meter indication for driving external recorder. 1.5 volts DC output for full scale meter deflection.
- ⑮ **ZERO ADJUST:** This control is used to set meter pointer to zero when calibrating for DC and resistance measurements.

Figure 3-1. Front and Rear Panel Controls

second may be made without loss of accuracy by removing the plastic nose on the Model 11036A and using in its place a 0.25 microfarad blocking capacitor in series with the exposed contact of the probe.

**CAUTION**

THE GRAY INSULATING MATERIAL AROUND THE AC PROBE IS POLYSTYRENE, A LOW-MELTING POINT MATERIAL. IT IS NOT POSSIBLE TO SOLDER TO THE CONTACT WHICH IS EXPOSED WITH THE PROBE NOSE REMOVED WITHOUT DESTROYING THE POLYSTYRENE.

Table 3-1. Possible Error When Measuring Voltage of Complex Waveforms

% Harmonic	True RMS Value	Voltmeter Indication
0	100	100
10% 2nd	100.5	90 to 110
20% 2nd	102	80 to 120
50% 2nd	112	75 to 150
10% 3rd	100.5	90 to 110
20% 3rd	102	87 to 120
50% 3rd	112	108 to 150

3-19. **VOLTAGE MEASUREMENT AT HIGH FREQUENCIES.** At frequencies above 100 megacycles the distance between the point of voltage measurement and anode of the probe diode must be made as short as possible. If feasible, substitute a small disc type capacitor of approximately 50 picofarads for the removable tip on the probe. Solder one terminal of the button capacitor to the measurement point in the circuit and not to the probe contact. The probe contact (with tip removed) can then contact the other terminal of the capacitor for the measurement.

3-20. At frequencies above 100 megacycles considerable voltage may be built up across ground leads and along various part of a grounding plane. Consequently, to avoid erroneous readings when measuring medium and high frequency circuits, use the ground clip lead on the shell of the probe to connect the circuit ground. In some cases at the higher frequencies it may be necessary to shorten the grounding lead on the probe.

3-21. For all measurements at higher frequencies, hold the molded nose of the probe as far from the external ground plane or from object at ground potential as can conveniently be done. Under typical conditions, this practice will keep the input capacitance several tenths of a picofarad lower than otherwise.

3-22. For measurements above approximately 250 megacycles it is almost mandatory that measurements be made on voltages which are confined to coaxial transmission line circuits. For applications of this type, the Model 11036A Probe is particularly suitable because the physical configuration of the diode and probe is that of a concentric line, and with a few precautions it can be connected to typical coaxial transmission line circuits with little difficulty.

3-23. To connect the probe into an existing coaxial transmission line, cut the line away so the center conductor of the line is exposed through a hole large enough to clear the body of the probe. The nose of the probe should be removed for this type of measurement. Connect one terminal of a button-type capacitor of approximately 50 picofarads to the center conductor of the coaxial line so that the other terminal of the capacitor will contact the anode connection of the probe. A close-fitting metal shield or bushing should be arranged to ground the outer cylinder of the probe to the outer conductor of the transmission line. This type of connection is likely to cause some increase in the standing wave ratio of the line at higher frequencies. The Model 11042A Probe T Connector is designed to do this job with SWR or less than 1.1 at 500 Mc (see Paragraph 1-11).

3-24. **EFFECT OF PARASITICS ON VOLTAGE READINGS.** At frequencies above 500 megacycles, leads or portions of circuits often resonate at frequencies two, three, or four times the fundamental of the voltage being measured. These harmonics may cause serious errors in the meter reading. Owing to the resonant rise in the probe circuit at frequencies above 1000 megacycles, the meter may be more sensitive to the harmonics than to the fundamental. To make dependable measurements at these frequencies, the circuits being measured must be free of all parasitics.

3-25. **EFFECT OF DC PRESENT WITH AC SIGNAL.** When measuring an AC signal at a point where there is a high DC potential, such as at the plate of a vacuum tube, the high DC potential may cause small leakage current through the blocking capacitor in the tip of the Model 11036A AC Probe. When the AC signal under measurement is small, the error introduced into the reading can be significant. To avoid leakage, an additional capacitor with a dielectric such as mylar or polystyrene which has high resistance to leakage is required. (Use 5 picofarads or higher, and insert the capacitor between the point of measurement and the probe tip.)

3-26. **PULSE MEASUREMENTS.**

3-27. **POSITIVE PULSES.** The Model 11036A AC Probe is peak-above-average responding and clamps the positive peak value of the applied voltage. This permits the probe to be used to measure the positive-voltage amplitude of a pulse, provided the reading obtained is multiplied by a factor determined from the following expression:

$$1.4 \left( 1 + \frac{t_1}{t_2} + \frac{K}{PRF} \right)$$

$t_1$  is the duration of the positive portion of the voltage in microseconds.

$t_2$  is the duration of the negative portion of the voltage in microseconds.

K is a factor determined from the expression  $R_0/t_1$  and the graph shown in Figure 3-6, where  $R_0$  is the source impedance of the pulse generator in kilohms, and  $t_1$  is the duration of the positive portion of the pulse in microseconds.

PRF is the pulse repetition frequency in pulses per second (pps).

Suppose, for example:

$$t_1 = 10 \text{ microseconds}$$

$$t_2 = 990 \text{ microseconds}$$

$$K = 0.55$$

$$\text{PRF} = 1000 \text{ pps}$$

To find K, assuming  $R_0 = 2$  kilohms and  $t_1 = 10$  microseconds:  $R_0/t_1 = 2/10^0 = 0.2$ . Location 0.2 on the X axis of the graph shown as Figure 3-6, and reading K where X and Y axes intersect the unmarked curve. If the ratio of  $R_0/t_1$  were greater than 1, multiply the X and Y axes by 10, and use the curve marked " $R_0/t_1$  and K each X10".

Solving the expression for the multiplying factor,

$$1.4 \left( 1 + \left( \frac{10}{990} + \frac{0.55}{1000} \right) \right) =$$

$$1.4 (1 + 0.01 + 0.00055) =$$

$$1.4 (1.01055) =$$

$$1.41477$$

### 3-28. NEGATIVE PULSES.

3-29. In the case of a 10 microsecond negative pulse ( $t_2$ ) and a pulse repetition frequency (PRF) of 1000 pps,  $t_1$  would be 990 microseconds. Thus  $T_0/t_1$  would be approximately 0, and from the graph it is seen that K is approximately 0. The expression would then reduce to

$$1.4 \left( 1 + \frac{990}{10} \right)$$

3-30. It can be seen that in the case of negative pulses of short duration much smaller readings will be obtained for an equivalent positive pulse. As a result, large multiplying factors must be used and unless the pulse voltage is large, these measurements may be impractical.

### 3-31. MEASURING RESISTANCE (Figure 3-7).

3-32. Before making resistance measurements, power must be removed from the circuit to be tested. Also, make sure capacitors are discharged to eliminate any residual voltage.

### 3-33. MEASURING DC NANO-AMPERE CURRENT (Figure 3-8).

3-34. The Model 410C can be used to measure nano-ampere leakage current in transistors and diodes. The three most sensitive DC voltage measurement ranges are used to measure DC nano-ampere currents.

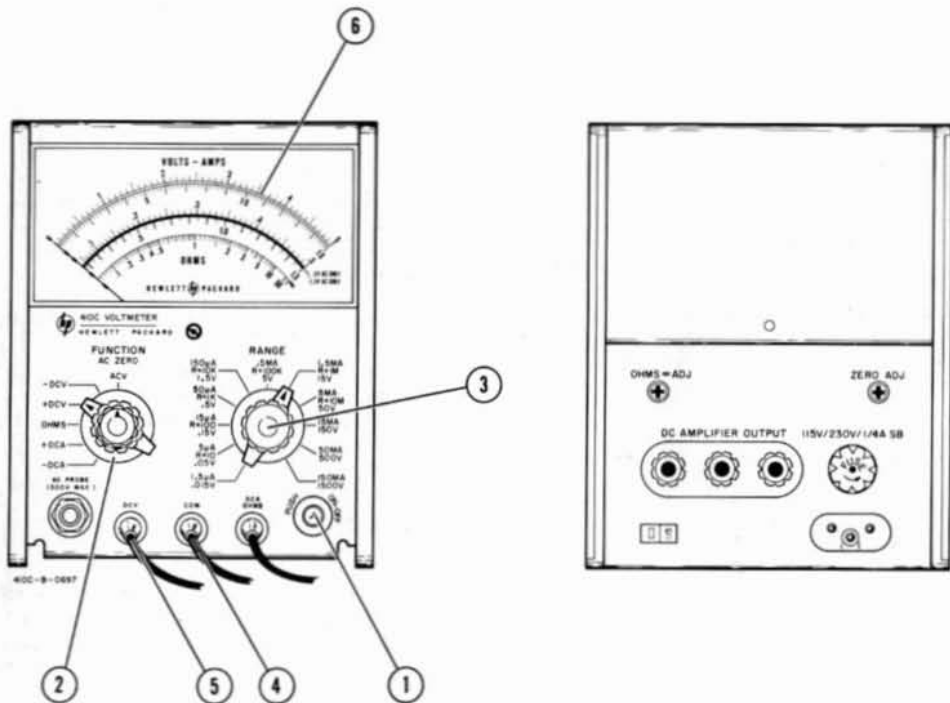

- ① Depress the AC power switch (neon - switch combination).
- ② Set FUNCTION SELECTOR to polarity desired (+DCV or -DCV).
- ③ Set RANGE to desired voltage position.
- ④ Connect COM Lead to the ground of circuit under test.
- ⑤ Touch DCV probe to test point.

- ⑥ Read voltage on the VOLTS-AMPS scale.

#### Note

Aging of the neon lamps in the chopper assembly can cause a change in chopper frequency which produces a low amplitude oscillatory movement of the meter pointer. If the meter pointer oscillates, rotate A3R5 ccw until oscillation stops.

Figure 3-2. DC Voltage Measurements



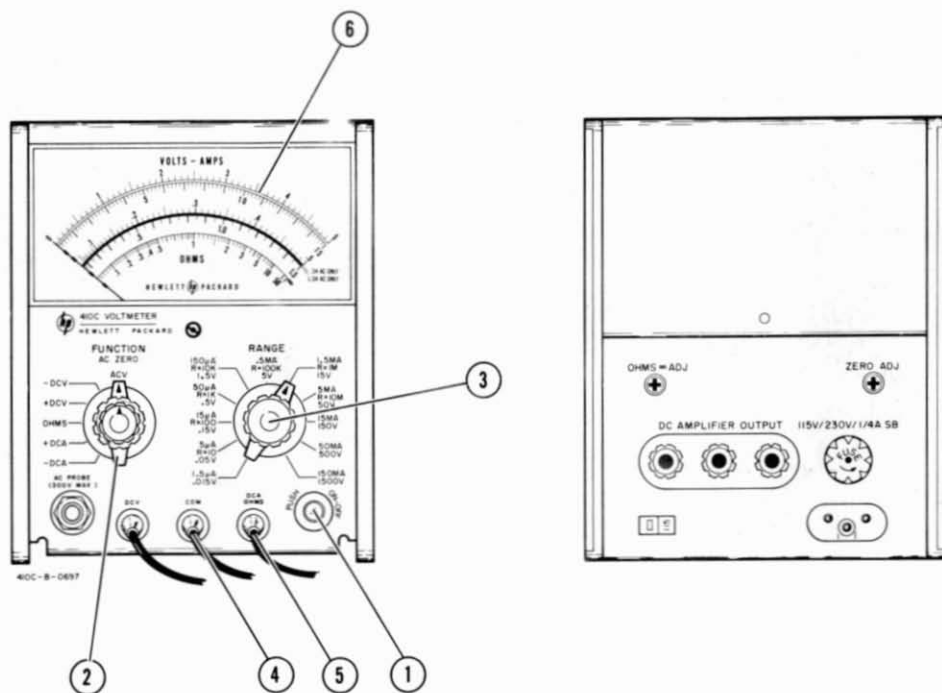

- ① Depress the AC power switch (neon-switch combination).
- ② Set FUNCTION SELECTOR to the polarity desired (+DCA or -DCA).
- ③ Set range to desired current position.
- ④ Connect COM Lead to the ground of circuit under test.
- ⑤ Connect the DCA ohms probe to the circuit to be tested.
- ⑥ Read the current on the VOLTS-AMPS scale.

Figure 3-3. DC Current Measurements

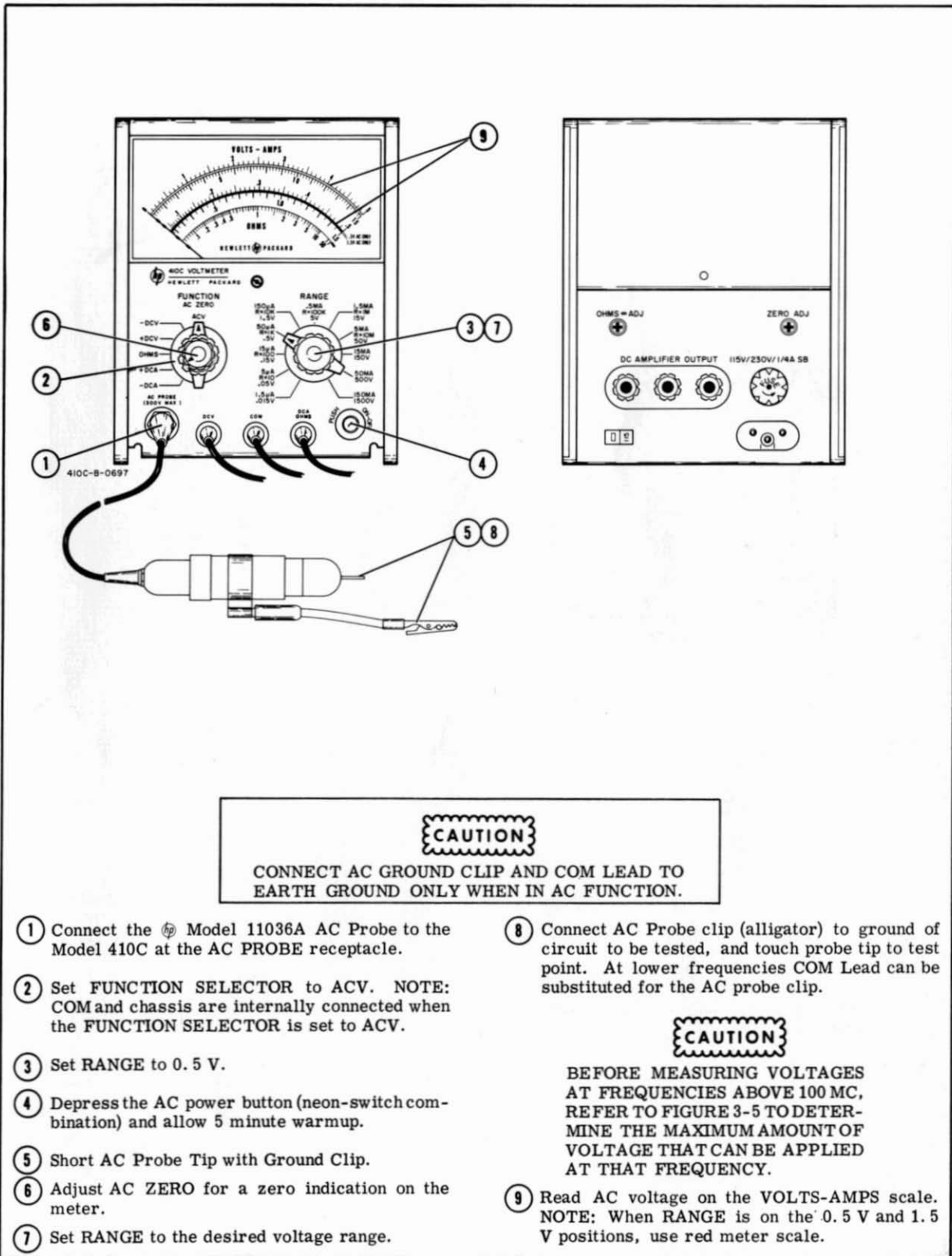

Figure 3-4. AC Voltage Measurements

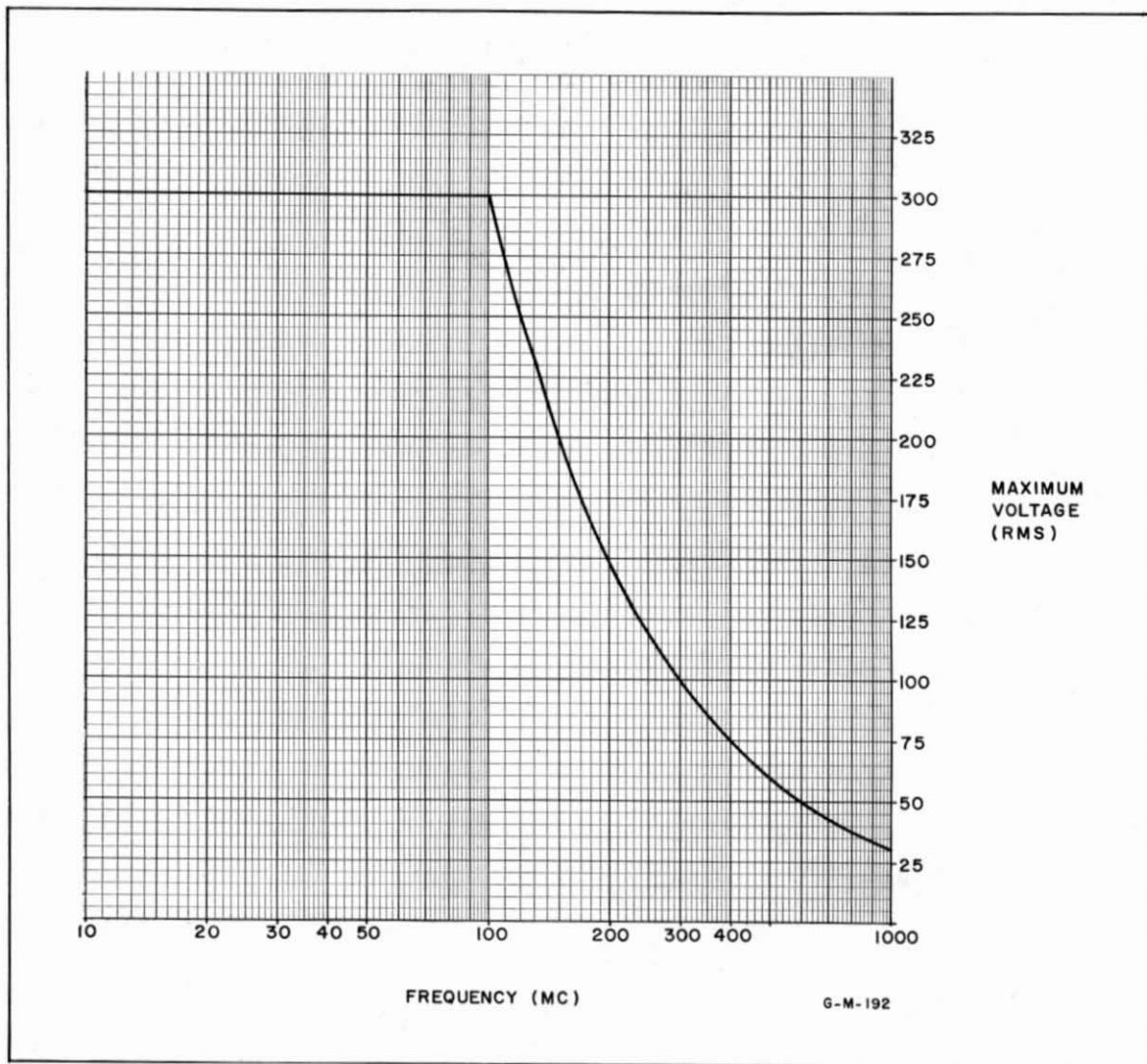

Figure 3-5. Maximum AC Voltage Chart for 11036A AC Probe

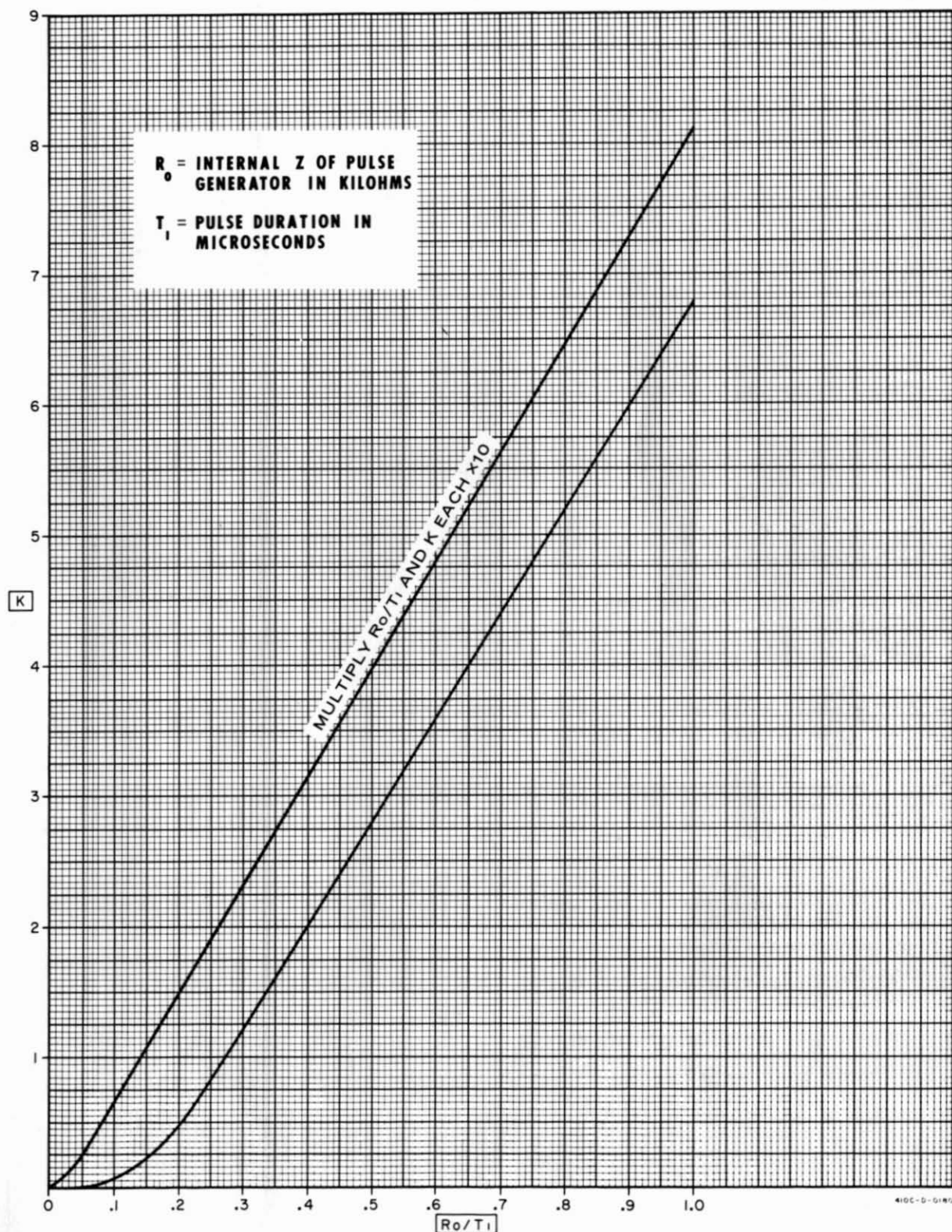
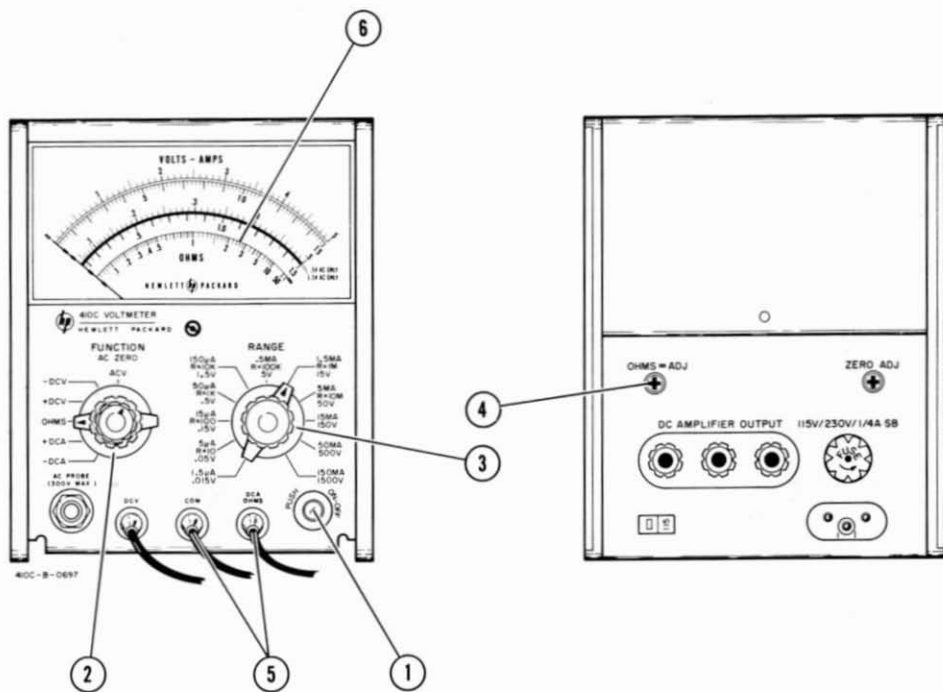

Figure 3-6. Graph Used in Calculation of Pulse Voltage Readings



Before making resistance measurements, remove power from circuit to be tested. Be sure to discharge capacitors to eliminate any residual voltage.

- ① Depress AC power switch (neon-switch combination).
- ② Set the FUNCTION SELECTOR to OHMS.
- ③ Set RANGE to desired position.

- ④ Adjust OHMS  $\infty$  ADJ. control on rear panel to obtain an  $\infty$  reading on the meter if necessary.
- ⑤ Connect COM and DCA OHMS leads across circuit to component to be tested.
- ⑥ Resistance is determined by multiplying the reading on the OHMS scale by the RANGE factor. EXAMPLE: If reading is 1.5 and factor is 10K, then resistance equals 15K ohms.

Figure 3-7. Resistance Measurements

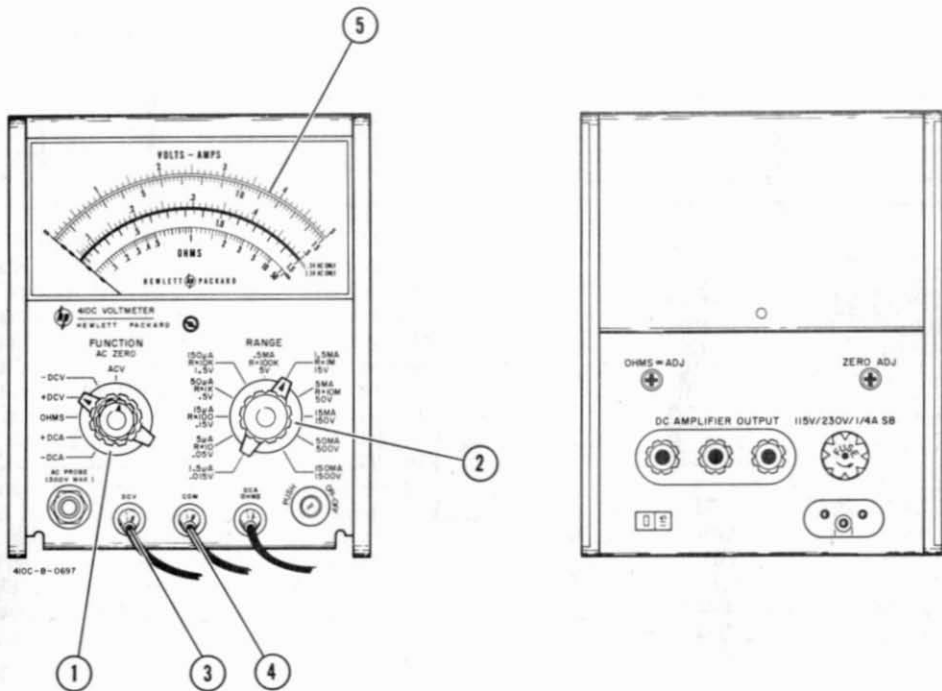

- ① Set the FUNCTION SELECTOR to +DCV or -DCV (depending on direction of current flow).
- ② Set RANGE to desired range (0.015 V, 0.05 V, or 0.15 V range).

Note

0.015 V range = 1.5 nano-amperes range

0.05 V range = 5.0 nano-amperes range  
0.15 V range = 15 nano-amperes range

- ③ Connect the DCV lead to the circuit under test.
- ④ Connect the COM lead to the circuit under test.
- ⑤ Read nano-amperes from the meter on the VOLTS-AMPS scale (top two on meter) which corresponds to the range selected.

Figure 3-8. DC Nano-Ampere Current Measurements

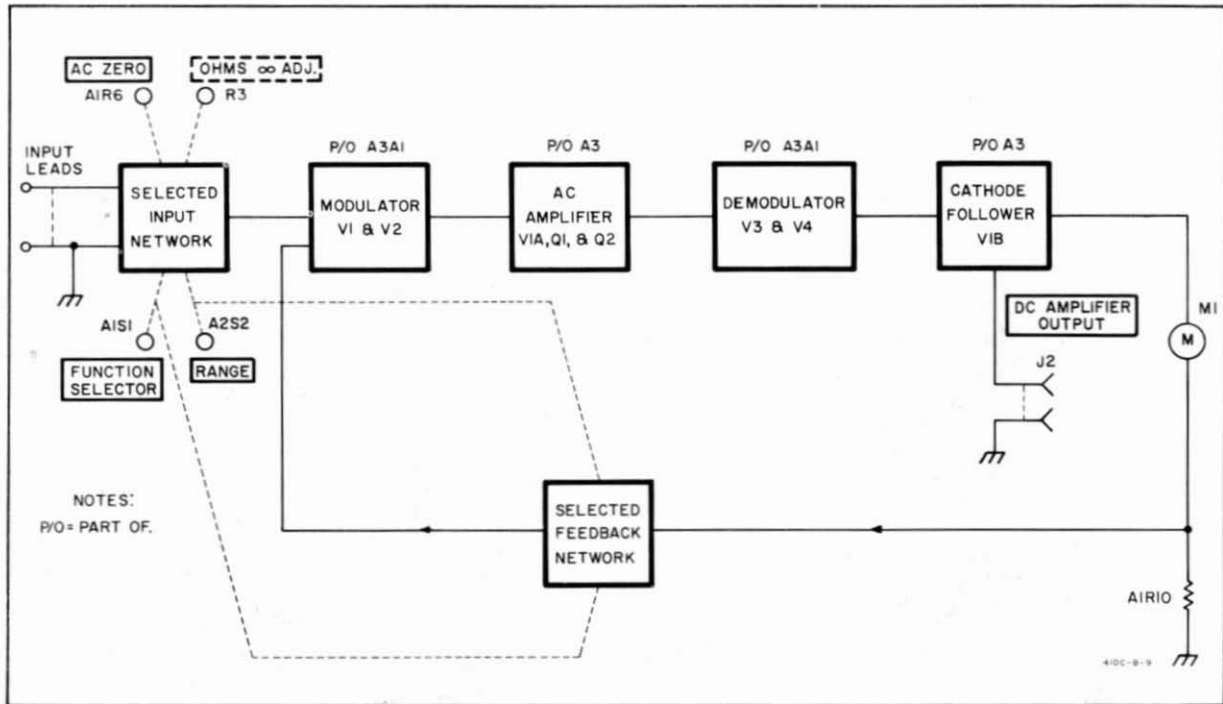

Figure 4-1. Block Diagram, Model 410C

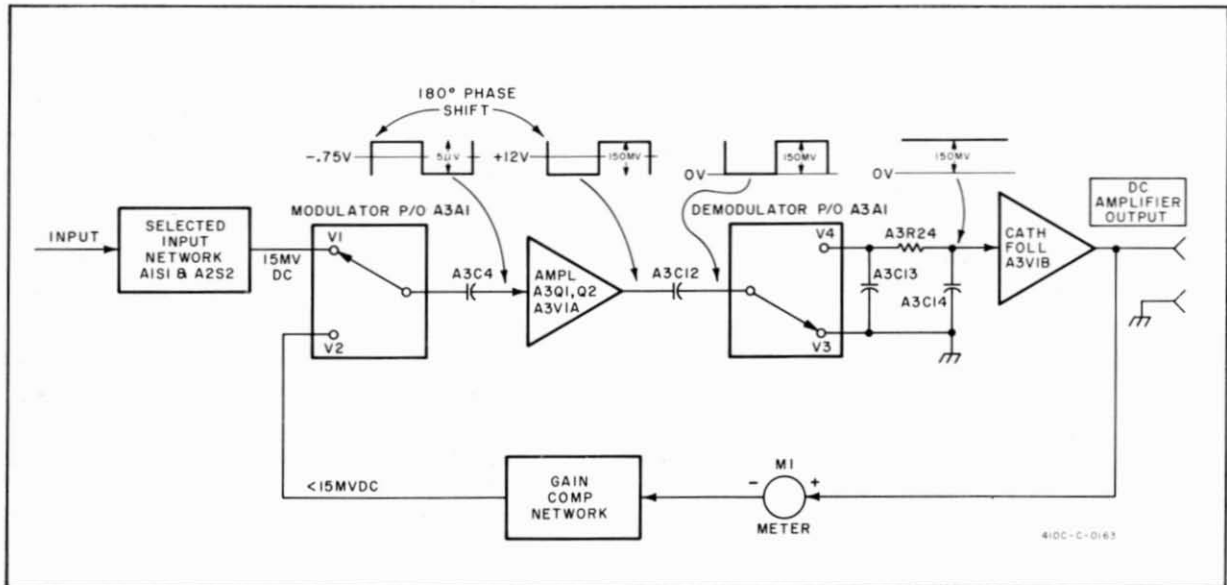

Figure 4-2. Modulator-Demodulator Mechanical Analogy

## SECTION IV

### THEORY OF OPERATION

#### 4-1. OVERALL DESCRIPTION.

4-2. The Model 410C includes an input network, a modulator-amplifier-demodulator, and a meter circuit. A block diagram of the Model 410C is shown in Figure 4-1.

4-3. Signals to be measured are applied through the appropriate input lead to the input network. AC voltages are detected in the AC probe, and therefore all signals to the input network are DC. The input network attenuates the DC signal to a level determined by RANGE and FUNCTION SELECTOR settings. The attenuated DC voltage is applied to the modulator which converts the DC to AC for amplification. The amplified AC signal is converted back to DC voltage in the demodulator and coupled to cathode follower V1B. The cathode follower output to the DC AMPLIFIER OUTPUT connector and meter circuit is a DC voltage proportional to the amplitude of the signal applied to the input. A portion of the voltage to the meter circuit is returned to the modulator as feedback. When the feedback voltage and attenuated DC voltage are nearly equal, the meter stabilizes.

#### 4-4. CIRCUIT DESCRIPTION.

##### 4-5. INPUT NETWORK.

4-6. The input network includes a precision voltage divider, which by means of the FUNCTIONSELECTOR and RANGE switches, provides a maximum of 15 millivolts at the modulator input regardless of the range set and signal applied. The  $\pm$ DCA,  $\pm$ DCV, OHMS, and ACV modes of operation are discussed below.

4-7. **DC CURRENT MEASUREMENTS:** Refer to Figure 4-3, throughout this explanation. The purpose of the input network is to provide proper attenuation of currents applied. Currents from 1.5  $\mu$ a to 150 ma full scale are applied with input impedance decreasing from 9K ohms on the 1.5  $\mu$ a range to approximately 0.3 ohms on the 150 ma range.

4-8. The change in input impedance is varied by using DC current shunts in conjunction with RANGE switch A2S1. The DC voltage developed across these shunt resistors, when applied through the modulator-amplifier-demodulator network to the meter, provide a deflection on the meter proportional to the DC current being measured.

4-9. **DC VOLTAGE MEASUREMENTS.** Refer to Figure 4-4 throughout this explanation. The purpose of the input network is to accurately attenuate the input signal to a maximum of 15 millivolts at the modu-

lator input. The network presents an input impedance of 10 megohms on the three most sensitive ranges and 100 megohms on all other ranges.

4-10. The resistor R1 (located in the DCV probe) in conjunction with resistors A2R10 through A2R26, provides the 10 megohm input impedance required for the three most sensitive DCV ranges. Resistors A2R4 and A3R30 are shunted out of the circuit by the RANGE switch on the three most sensitive DCV ranges.

4-11. When using the eight less sensitive ranges, A2R4 and A3R30 are placed in series with R1 and A2R10 through A2R26 to present more than 100 megohm impedance to the input.

4-12. A3R30 is used to calibrate full scale on the 1500 volt range. (See Paragraph 5-35.)

4-13. **RESISTANCE MEASUREMENTS.** The purpose of the input network shown in Figure 4-5 is to place approximately 0.6 volt DC source in series with a known (reference) resistance. The resistance to be measured is placed in parallel with the known resistance, which changes the voltage proportionally. The maximum changes in voltage applied to the modulator is 15 mv because of attenuation provided by A2R4, A3R30, and A1R2.

4-14. A DC current of approximately 60 ma is supplied at the junction of A2R22 and A2R23 through A7R10, R3, A2R2 and A2R1 to the input network. The OHMS  $\infty$  ADJ., R3, sets the meter for full scale ( $\infty$ ). Resistor A2R1 is shorted out in the X1M position of the RANGE switch; resistors A2R1 and A2R2 are shorted out in the X10M range. The resistors A2R2 and/or A2R1 are electrically removed from the circuit to increase the voltage at the junction of A2R22 and A2R23. This is done to compensate for the loading of the attenuator (A2R4, A3R30, and A1R2) on these ranges.

4-15. **AC VOLTAGE MEASUREMENTS.** Refer to Figure 4-6 throughout this explanation. Voltage at the AC probe is converted to DC and applied to the input network. The input signal is attenuated to produce a maximum of about 15 millivolts at the modulator input. AC zero adjustment of meter pointer is made with the AC ZERO control.

##### 4-16. MODULATOR-DEMODULATOR.

4-17. Refer to the Amplifier Schematic, Figure 5-11, and to the Mechanical Analogy Schematic, Figure 4-2 throughout this explanation.

4-18. The input network applies approximately 15 millivolts DC, for full scale meter deflection (positive or negative, depending on the polarity of the



voltage or current being measured) to the neon-photoconductor chopper. Also applied to the opposite side of the chopper is the amplifier feedback voltage, which is of the same polarity and approximately 5 microvolts lower in amplitude than the input voltage. The modulator-chopper consists of two photoconductors, A3A1V1 and A3A1V2, which are alternately illuminated by two neon lamps, A3A1DS1 and A3A1DS2, respectively. The neon lamps are part of a relaxation oscillator whose frequency is controlled by A3R5. The oscillator frequency is nominally set to 100 cps for operation from 60 cps power line, or to 85 cps for 50 cps line. This frequency is selected so that it is not harmonically related to the power line frequency, precluding possible beat indications on the meter.

4-19. As the photoconductors are alternately illuminated by the neons, their respective resistances are low (conductive) when illuminated and high (non-conductive) when darkened. Therefore, the input voltage and feedback voltage are alternately applied to the input amplifier. The amplitude of the resultant signal to the amplifier is the voltage difference between the input and feedback voltages.

4-20. The chopped DC signal is amplified by a three stage RC amplifier, consisting of A3V1A, A3Q1 and A3Q2. The amplified signal to the input of the demodulator-chopper is 180° out of phase with the output of the modulator-chopper.

4-21. The demodulator-chopper consists of two photoconductors, A3A1V3 and A3A1V4, which are alternately illuminated by neon lamps A3A1DS1 and A3A1DS2, respectively. Approximately 150 millivolts square-wave is applied to the demodulator from the amplifier. Since the same neon lamps illuminate both the modulator and demodulator photoconductors, operation of the two choppers is synchronous. Therefore, when A3A1V1 is sampling the input voltage, A3A1V3 is clamping the amplified and inverted difference voltage to ground. Alternately, when A3A1V2 is sampling the feedback voltage, A3A1V4 is charging capacitors A3C13 and C3C14 to the peak value of the square-wave. These capacitors maintain this charge so long as the input voltage remains constant by virtue of having no discharge path and because they are being repetitively recharged by the demodulator.

4-22. Therefore, a DC potential, proportional to the difference between the input and feedback voltages, is applied to the grid of the cathode follower and subsequently to meter circuit and DC AMPLIFIER OUTPUT connector. A portion of the meter circuit voltage is fed back to the modulator. The meter stabilizes when the feedback voltage and input voltages are nearly equal.

#### 4-23. THE FEEDBACK NETWORK.

4-24. The feedback network drives the meter and determines the DC gain of the amplifier. The feedback is varied depending on the position of the FUNCTION and RANGE selectors. The different feedback configurations are discussed below.

4-25. FEEDBACK NETWORK FOR  $\pm$ DCA, OHMS, AND  $\pm$ DCV. Figures 4-3, 4-4 and 4-5 show the feedback configuration for all positions of the FUNCTION SELECTOR except ACV. The meter is electrically inverted for  $\pm$ DCV and  $\pm$ DCA modes of operation. The DC OUTPUT ADJ., A6R20 sets the output voltage. The DC pot, A6R18 determines the amount of feedback to the modulator. The resistor A2R30 is in the circuit in the  $\pm$ .015 DCV and  $\pm$ 1.5  $\mu$ A modes of operation, to decrease feedback and thus increase amplifier gain to compensate for the decrease in input signal to the modulator on these ranges.

4-26. FEEDBACK CIRCUIT FOR AC VOLTAGE MEASUREMENTS. Figure 4-6 shows the feedback configuration for the ACV position of the FUNCTION SELECTOR switch, A1S1. The resistors that are placed in the circuit by the RANGE switch program the amplifier gain to compensate for the non-linear response of the AC probe. A6R16 and A6CR1 compensate the non-linear response of the AC probe to the linear calibration of the upper meter scale on the 5 volt range.

#### 4-27. POWER SUPPLY.

4-28. PRIMARY POWER. Refer to Figure 5-9 through-out this explanation. Either 115 or 230 volt ac power is connected through fuse F1 (0.25 amp slow-blow) and switch S1 to the primary of power transformer T1. Switch S2 connects T1 primaries in parallel for 115 volt operation or in series for 230 volt operation.

4-29. UNREGULATED AND ZENER REGULATED POWER SUPPLY. Full wave rectifier CR1 and CR2 produces unregulated +270 volts, which is used to drive the photochopper neons. Unregulated +175 volts and +140 volts are tapped off and are used to provide B+ to the plates of A3V1B and A3V1A, respectively. Zener regulators A7CR6 and CR7 provide regulated +38 volts and -9 volts to bias A3Q1 and A3Q2. Filtering of the outputs is provided by the RC network consisting of A7R1 through A7R3 and C5A through C5D.

4-30. SERIES REGULATED POWER SUPPLY. The output of the full wave rectifier CR3 and CR4 is regulated by transistor Q1, which is connected in series with the output. Zener diode A7CR8 provides reference voltage to the base of Q1. Regulated +6 volts is supplied to the filaments of A3V1A/B and the AC Probe diode A8V1. +0.6 volts is provided through A7R10 to R3, the OHMS  $\infty$  ADJ. control. Filtering of the outputs is provided by C6A and C6B.

4-31. STANDBY FILAMENT SUPPLY. The filament tap (T1, Pins 1 and 2) provides 6.0 volts ac to the filament of the AC probe diode, A8V1, so that the filament remains warm when the Model 410C is being used in modes of operation other than ACV. When FUNCTION selector A1S1 is switched to ACV, 6.0 volts AC is removed from the filament and 6 volts DC is applied. Therefore, the ACV mode is ready for immediate use, without waiting for the filament to warm up.

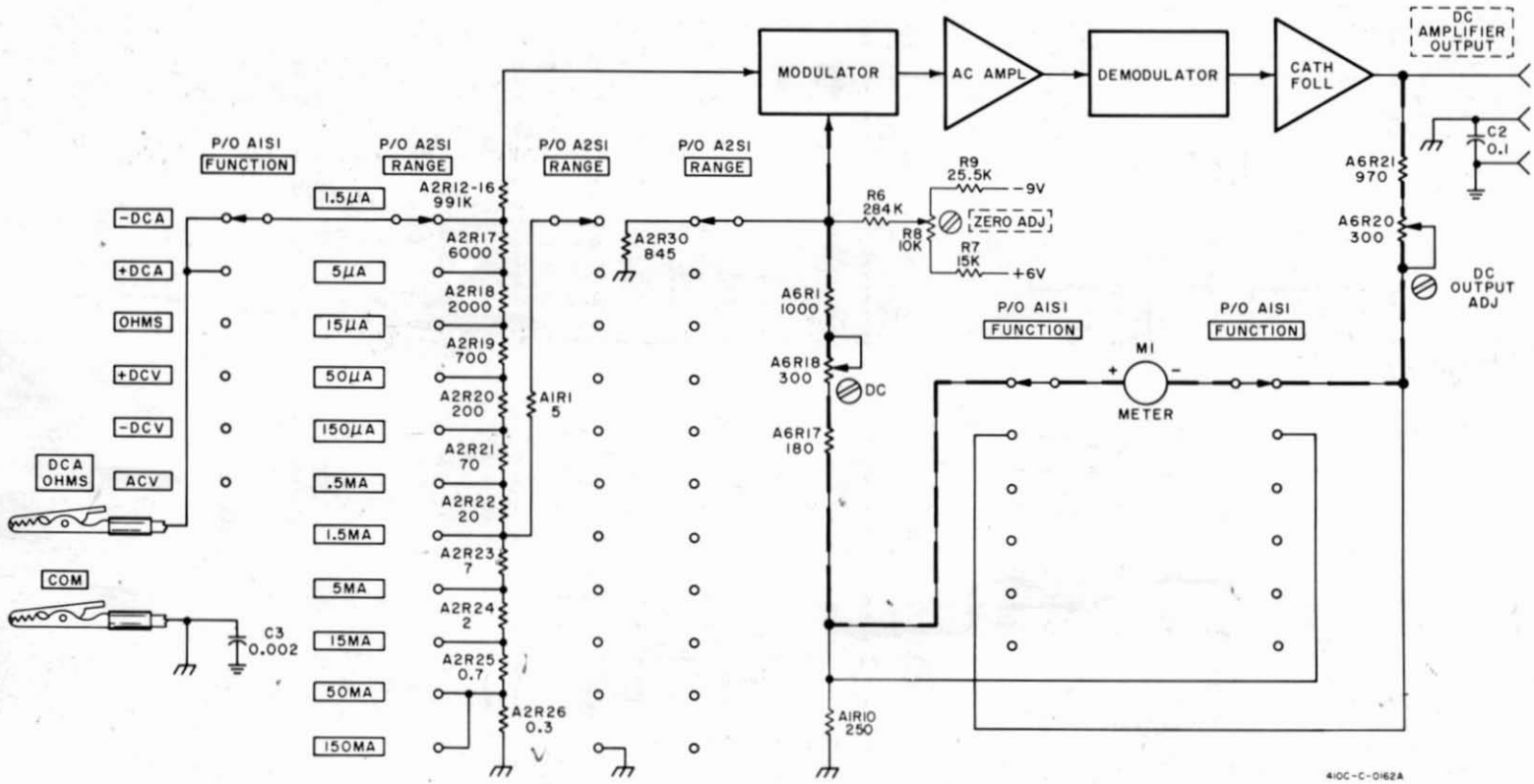

410C-C-0162A

Figure 4-3. Simplified Schematic, DC Current Measurement

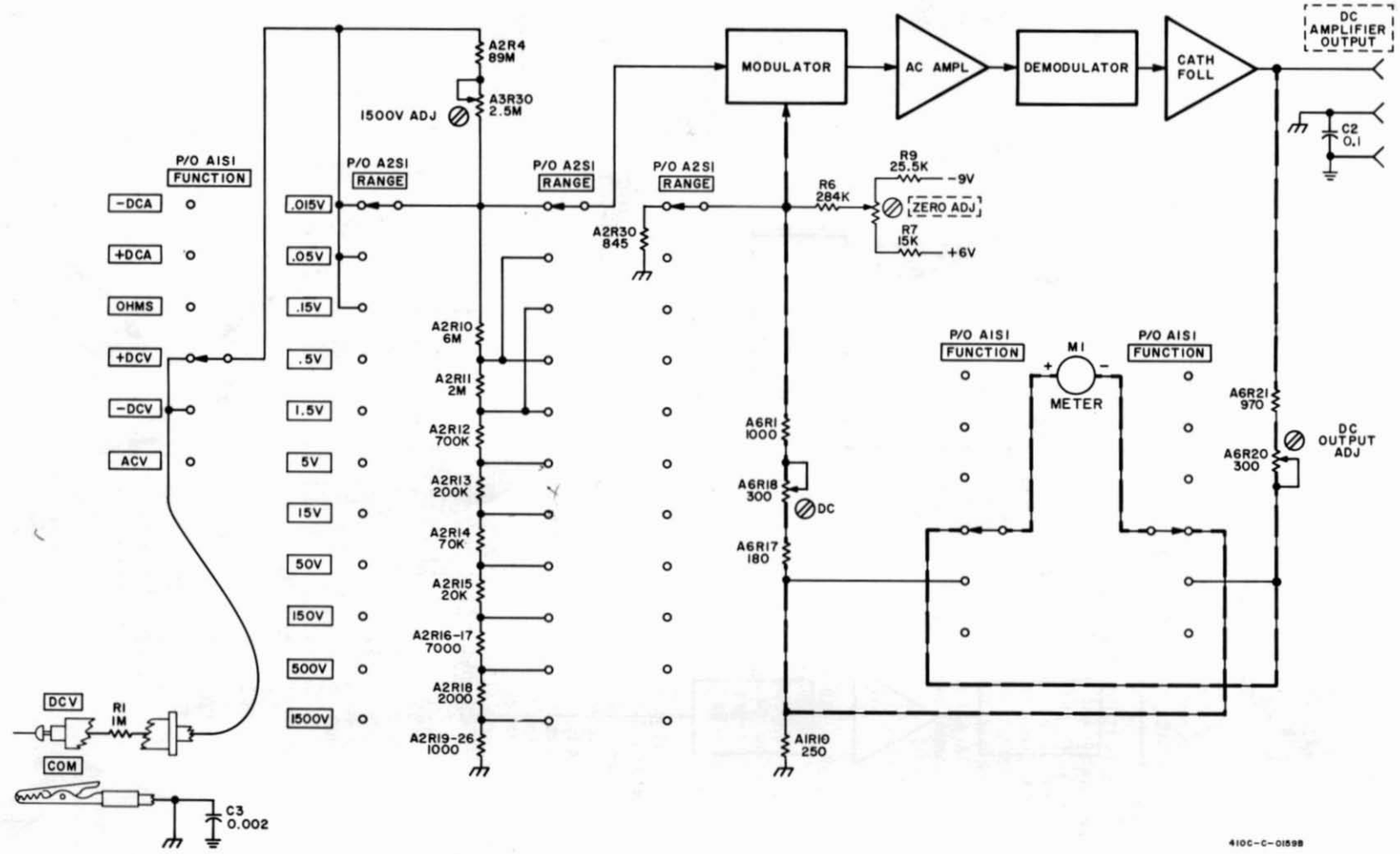

Figure 4-4. Simplified Schematic, DC Voltage Measurements

410C-C-01598

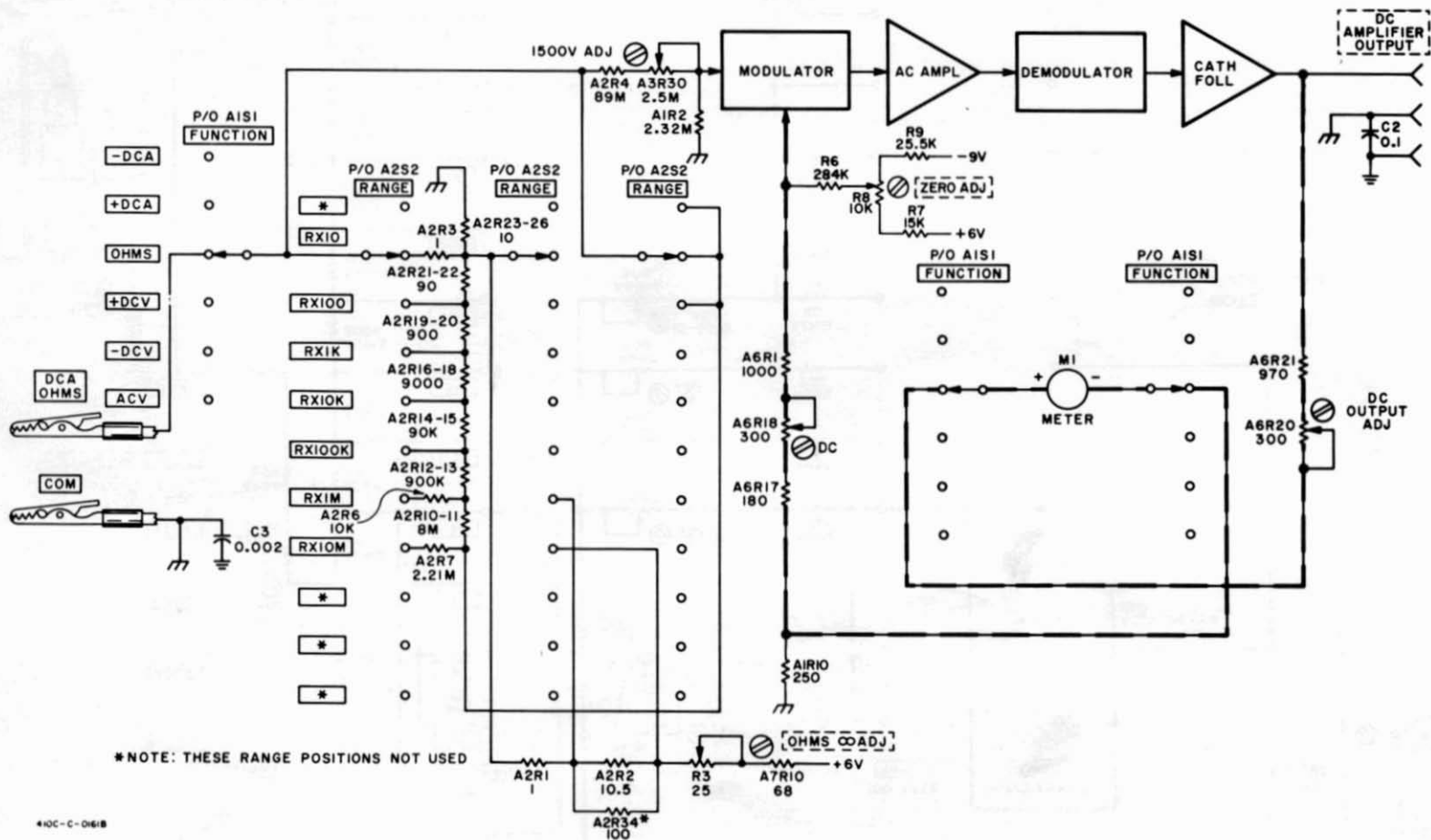

Figure 4-5. Simplified Schematic, Resistance Measurement

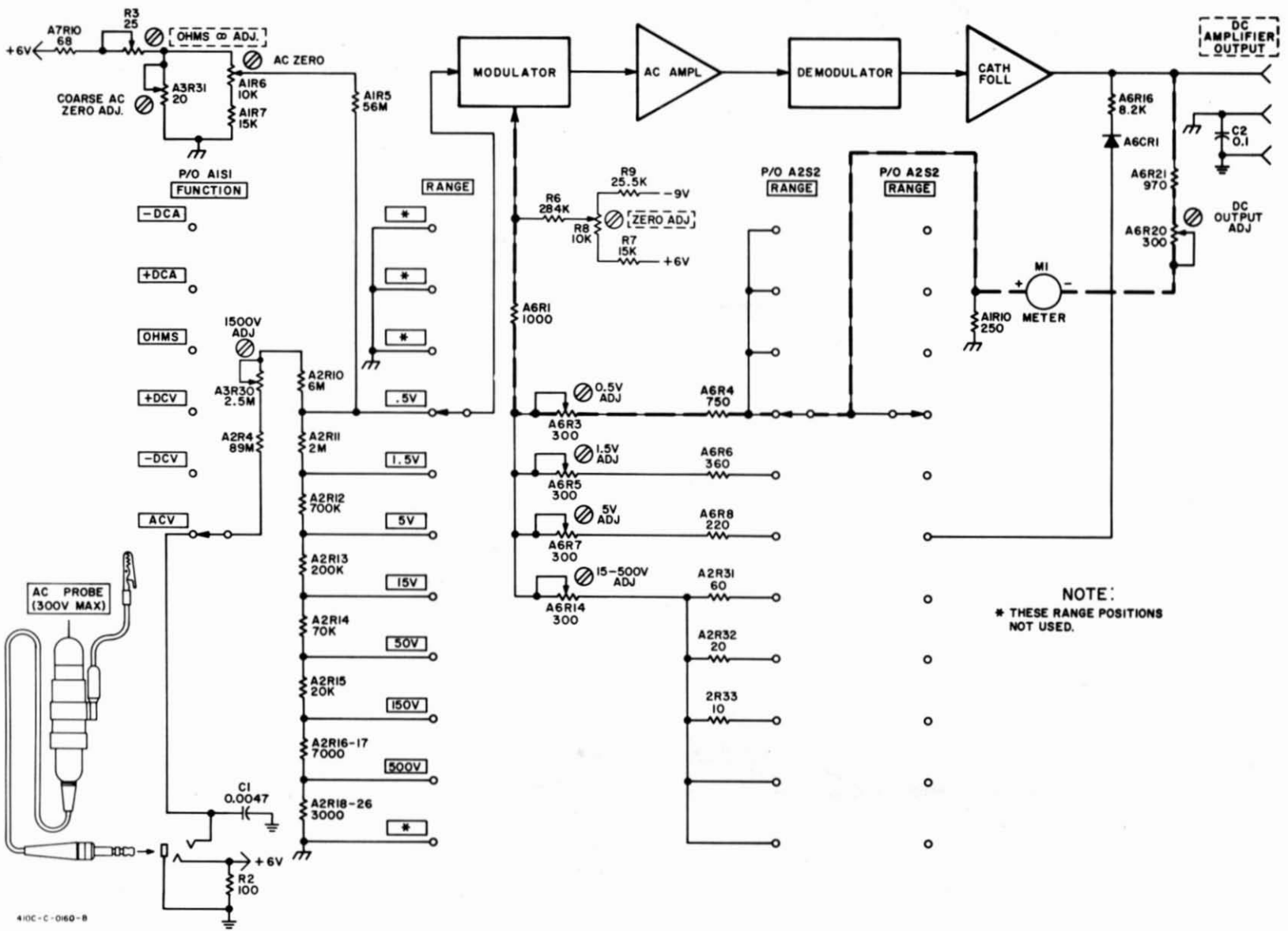

Figure 4-6. Simplified Schematic, AC Voltage Measurement

Table 5-1. Recommended Test Equipment

Instrument Type	Required Characteristics	Use	Recommended Model
Voltmeter Calibrator	Range: 0.015 to 300 v Frequency: Dc and 400 cps Accuracy: $\pm 0.3\%$ ac $\pm 0.2\%$ dc	AC and DC Accuracy Checks and Calibration Adjustments	<i>hp</i> Model 738BR Voltmeter Calibrator
Oscillator	Frequency: 20 cps to 10 Mc Output: 2.0 v	Frequency Response Test	<i>hp</i> Model 652A Test Oscillator
DC Power Supply	Range: 0 to 10 v continuous	DC Ammeter Accuracy Checks	<i>hp</i> Model 723A DC Power Supply
DC Voltmeter	Range: 10 v Accuracy: $\pm 0.2\%$	Accuracy Checks; Power Supply Measurements; Troubleshooting	<i>hp</i> Model 3440A/3441A/3443A Digital Voltmeter
VHF Signal Generator	Frequency: 10 Mc to 480 Mc Output: 1.0 v	Frequency Response Test	<i>hp</i> Model 608 VHF Signal Generator
UHF Signal Generator	Frequency: 480 Mc to 700 Mc	Frequency Response Test	<i>hp</i> Model 612A UHF Signal Generator
AC Voltmeter	Range: 120 v	Power Supply Measurements (ripple)	<i>hp</i> Model 3400A RMS Voltmeter
Electronic Counter	Frequency Range: to at least 102 cps	Chopper Frequency Adjust	<i>hp</i> Model 5211A Electronic Counter
Ohmmeter	Range: 100 M $\Omega$ Accuracy: $\pm 5\%$	Troubleshooting	<i>hp</i> Model 412A DC VTVM
Micro-Potentiometer	Frequency Range: 10 Mc to 700 Mc Output Voltage: 0.44 v rms Accuracy: NBS calibrated	Frequency Response Test	Ballantine Model 440 Micro-Potentiometer
Probe-T-Connector	For use with 50 ohm transmission line	Frequency Response Test	<i>hp</i> Model 11042A Probe-T-Connector
Connector Adapter	Type N male to BNC female	Frequency Response Test	<i>hp</i> Part No. 1250-0067
Connector Adapter	BNC to binding post	Frequency Response Test	<i>hp</i> Part No. 10110A
Connector Adapter	Type "N" male to Type "N" female	Frequency Response Test	<i>hp</i> Part No. 11501A
50 $\Omega$ termination	Frequency Range: 10 Mc to 700 Mc Low reflection	Frequency Response Test	<i>hp</i> Part No. 908A
50 ohm feed-thru	Male BNC to female BNC	Performance Checks	<i>hp</i> Model 11048B
Resistors:			
10 M $\Omega$	Accuracy: $\pm 1\%$	Performance Checks	<i>hp</i> Part No. 0730-0168
56 K	Accuracy: $\pm 1\%$	Performance Checks	<i>hp</i> Part No. 0730-0053
10 K	Accuracy: $\pm 1\%$	Performance Checks	<i>hp</i> Part No. 0727-0157
1 K	Accuracy: $\pm 1\%$	Chopper Frequency Adjust	<i>hp</i> Part No. 0727-0751
1.5 K	Accuracy: $\pm 1\%$	Performance Checks	<i>hp</i> Part No. 0730-0017
56 ohms	Accuracy: $\pm 1\%$	Performance Checks	<i>hp</i> Part No. 0811-0341
10 ohms	Accuracy: $\pm 1\%$	Performance Checks	<i>hp</i> Part No. 0727-0335

## SECTION V MAINTENANCE

### 5-1. INTRODUCTION.

5-2. This section contains maintenance procedures for the Model 410C Electronic Voltmeter.

### 5-3. TEST EQUIPMENT REQUIRED.

5-4. The test equipment required to maintain and adjust the Model 410C is listed in Table 5-1. Equipment having similar characteristics may be substituted for items listed.

### 5-5. PERFORMANCE CHECKS.

5-6. The performance checks presented in this section are front panel operations designed to compare the Model 410C with its published specifications. These operations may be incorporated in periodic maintenance, post repair and incoming quality control checks. These operations should be conducted before any attempt is made at instrument calibration or adjustment. During performance checks, periodically vary the line voltage to the Model 410C,  $\pm 10\%$  on either 115 v or 230 v operation. A 1/2 hour warm-up period should be allowed before these tests are conducted.

### 5-7. ALTERNATE CALIBRATION VOLTAGE SOURCE.

5-8. Should it be necessary to use the  $\text{hp}$  Model 738AR Voltmeter Calibrator to conduct these Performance Checks, the arrangement described in Figure 5-1 will

provide the necessary voltage values required. However, the  $\text{hp}$  Model 738BR Voltmeter Calibrator is the preferred instrument for these operations.

### 5-9. MECHANICAL METER ZERO.

- a. Turn instrument on. Allow at least a 20 minute warm-up period.
- b. Turn voltmeter off, and allow 30 seconds for all capacitors to discharge.
- c. Rotate mechanical zero-adjustment screw on front panel clockwise until pointer reaches zero, moving up scale.
- d. If for some reason the pointer should overshoot zero, repeat step c until desired results are obtained.
- e. When pointer has been positioned at zero, rotate zero-adjust screw slightly counterclockwise to free it. If meter pointer moves to the left during this action, repeat steps c and e.

### 5-10. DC VOLTMETER OPERATION.

### 5-11. ACCURACY CHECK (DCV).

- a. Short Model 410C DCV probe to COM lead; set pointer to zero using rear panel adjustment (ZERO ADJ).

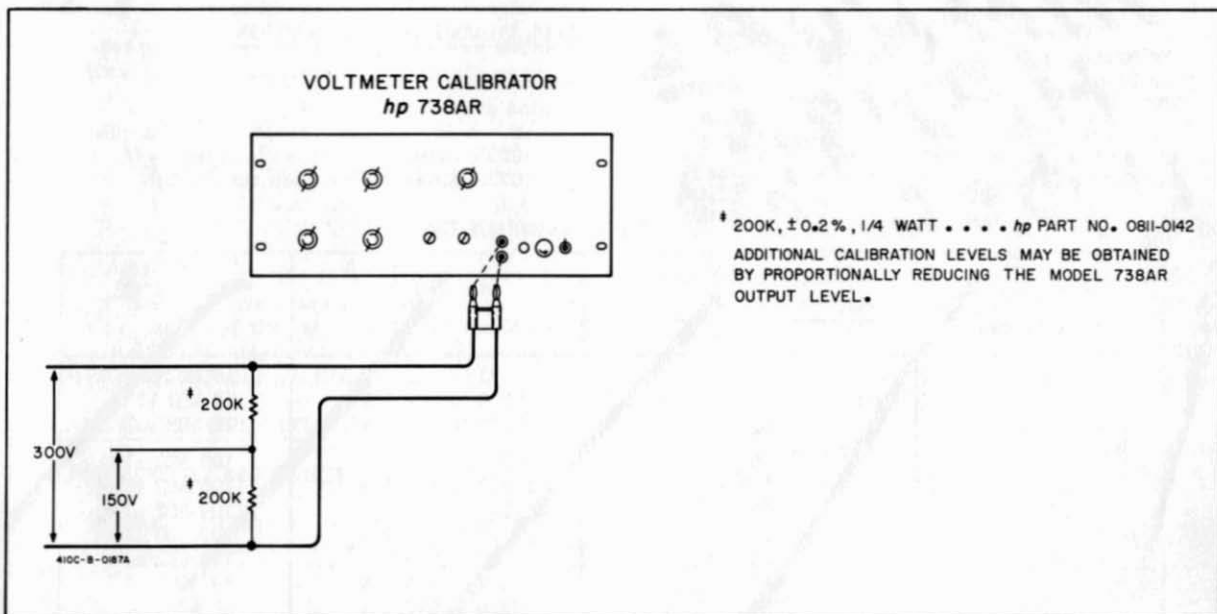

Figure 5-1. Alternate Calibration Voltage Source

b. Set the Model 410C FUNCTION SELECTOR to the +DCV position; RANGE switch to .015 V. Connect Model 410C DCV and COM cables to the Voltmeter Calibrator (Model 738BR) output terminals.

c. Adjust voltmeter calibrator and Model 410C to settings listed in Table 5-2.

d. Model 410C should indicate readings within limits specified. If not, refer to Paragraph 5-33 for adjustment procedure.

Table 5-2. DCV Accuracy Test

Model 410C Range Settings	Voltmeter Calibrator Settings	Model 410C Meter Readings
	Voltage	
.015 V	±.015	.0147 to .0153 V
.05 V	±.05	.049 to .051 V
.15 V	±.15	.147 to .153 V
.5 V	±.5	.49 to .51 V
1.5 V	±1.5	1.47 to 1.53 V
5 V	±5	4.9 to 5.1 V
15 V	±15	14.7 to 15.3 V
50 V	±50	49 to 51 V
150 V	±150	147 to 153 V
500 V	±300	290 to 310 V
1500 V	±300	270 to 330 V

5-12. INPUT RESISTANCE CHECK (DCV).

a. Connect an external resistor,  $R_{series}$ , of 10 M ohms (Part No. 0370-0168) in series between the voltmeter calibrator and the DCV cable of the Model 410C.

b. Set Model 410C FUNCTION selector to +DCV; RANGE to .015 V.

c. Adjust voltmeter calibrator and Model 410C to settings listed in Table 5-3.

d. Model 410C should read within limits specified. If not, refer to Paragraph 5-35 for adjustment procedure.

Table 5-3. DCV Input Resistance Test

Model 410C Range Settings	Voltmeter Calibrator Settings	Model 410C Meter Readings	Model 410C $R_{in}$
	Voltage		
.015 V	.015	.00715 to .00765 V	10 MΩ ±1%
.05 V	.05	.0238 to .0255 V	10 MΩ ±3%
.15 V	.15	.0715 to .0765 V	10 MΩ ±3%
.5 V	.5	.453 to .455 V	100 MΩ ±1%
1.5 V	1.5	1.360 to 1.365 V	100 MΩ ±1%
5 V	5	4.53 to 4.55 V	100 MΩ ±1%
15 V	15	13.60 to 13.65 V	100 MΩ ±1%
50 V	50	45.3 to 45.5 V	100 MΩ ±1%
150 V	150	136.0 to 136.5 V	100 MΩ ±1%
500 V	300	272.0 to 272.5 V	100 MΩ ±1%
1500 V	300	272.0 to 272.7 V	100 MΩ ±1%

NOTE: Input resistance test is dependent on calibration of Model 410C.

NOTE  
 This method of input resistance measurement is a result of a voltage divider:

$$R_{in} = \left( \frac{E_{meter}}{E_{input} - E_{meter}} \right) R_{series}$$

5-13. DC AMMETER OPERATION.

5-14. ACCURACY CHECK (DCA).

a. Figure 5-2 describes the test arrangement required for this operation. The following additional equipment will also be required:

DC Power Supply (Model 723A)

DC Voltmeter (Model 3440A/3442A)

10 Ω, 1%, 1 w resistor (Part No. 0727-0335)

56 Ω, 1%, 1/2 w resistor (Part No. 0811-0341)

10 K, 1%, 1 w resistor (Part No. 0727-0157)

56 K, 1%, 1 w resistor (Part No. 0730-0053)

b. Connect the Model 410C as shown in Figure 5-2; FUNCTION SELECTOR to +DCA; RANGE to 150 MA.

c. Use 56 ohm resistor for R1 and 10 ohm resistor for R2.

d. Adjust dc power supply to obtain reading on dc voltmeter specified in Table 5-4; change R1 and R2 according to Table 5-4.

e. Model 410C should read within limits specified in Table 5-4. If not, refer to Paragraph 5-33 for adjustment procedure.

5-15. OHMMETER OPERATION.

5-16. OHMMETER ACCURACY CHECK.

a. A 10 ohm ±1% resistor (Part No. 0727-0335) and a 10 M ±1% resistor (Part No. 0730-0168) will be required for this test.



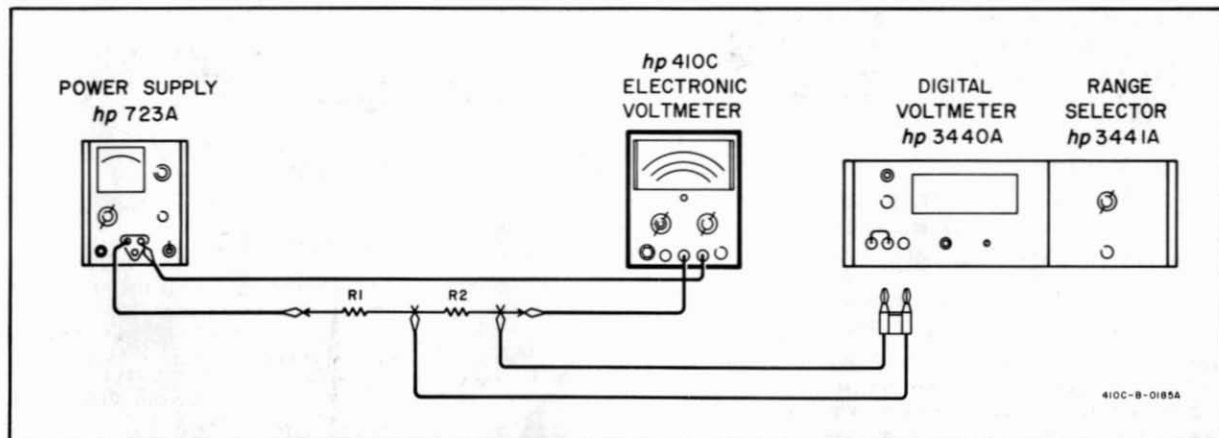

Figure 5-2. DC Ammeter Operation

Table 5-4. DCA Accuracy Test

Model 410C Range Settings	DC Voltmeter Readings	Model 410C Meter Readings	R <sub>1</sub> Ω	R <sub>2</sub> Ω
150 MA	1.4 V	135.5 to 144.5 MA	56	10
50 MA	.4 V	38.5 to 41.5 MA	56	10
15 MA	.14 V	13.55 to 14.55 MA	56	10
5 MA	.04 V	3.85 to 4.15 MA	56	10
1.5 MA	.014 V	1.35 to 1.45 MA	56	10
.5 MA	.004 V	0.385 to 0.415 MA	56	10
150 μa	1.38 V	133.5 to 142.5 μa	56 K	10 K
50 μa	0.46 V	44.5 to 47.5 μa	56 K	10 K
15 μa	0.138 V	13.35 to 14.25 μa	56 K	10 K
5 μa	0.046 V	4.45 to 4.75 μa	56 K	10 K
1.5 μa	0.014 V	1.36 to 1.45 μa	56 K	10 K

b. Set Model 410C FUNCTION SELECTOR to OHMS; RANGE to RX10.

c. Set pointer to ∞ using rear panel adjustment (OHMS ADJ) if required.

d. Connect COM and DCA OHMS cables across 10 ohm resistor.

e. Meter should read 10 ohms (±5%).

f. Set Model 410C RANGE to RX10M. Replace 10 ohm resistor with 10 M ohm resistor.

g. Meter should read 10 M ohms (±5%).

h. If both of these ranges function properly, it can be assumed that the remainder will also. If meter does not function properly, refer to Paragraph 5-36 for adjustment procedure.

panel of Model 410C. Set DC Voltmeter RANGE to 10 V.

c. Set Model 410C FUNCTION SELECTOR to +DCV; RANGE to .015 V.

d. Adjust voltmeter calibrator for +.015 VDC output.

e. The dc voltmeter should read +1.5 v. This will verify a gain of 100, where the gain equals  $E_{DC \text{ out}} / E_{DC \text{ in}}$

f. If dc voltmeter does not read at least 1.5 v, refer to Paragraph 5-37 for proper adjustment procedure.

#### 5-17. AMPLIFIER OPERATION.

#### 5-18. AMPLIFIER GAIN CHECK.

a. Connect Voltmeter Calibrator (Ⓢ Model 738BR) output to Model 410C DCV and COM cables.

b. Connect DC Voltmeter (Ⓢ Model 3440A/3441A) to DC AMPLIFIER OUTPUT on rear

#### 5-19. AC REJECTION CHECK.

a. An Oscillator (Ⓢ Model 200SR) and an RMS Voltmeter (Ⓢ Model 3400A) are required for this check.

b. Set 410C FUNCTION SELECTOR to -DCV; RANGE to .015 V.

c. Connect Oscillator output to Model 410C DCV and COM cables and input of rms voltmeter. Set rms voltmeter to read 10 v.

- d. Adjust test oscillator to provide 3.18 v (4.5 v peak) reading on rms voltmeter at 50 cps.
- e. Model 410C should not read more than 2.25 mv verifying 66 db ac rejection at 50 cps.
- f. Increase frequency to check ac rejection above 50 cps.
- g. Switch Model 410C FUNCTION SWITCH to +DCV and repeat steps e and f.

#### 5-20. OUTPUT LEVEL CHECK.

- a. A Voltmeter Calibrator (hp Model 738BR) and a DC Voltmeter (hp Model 3440A/3441A) will be required for this check.
- b. Connect dc voltmeter to dc amplifier OUTPUT on Model 410C rear panel. Place ground lead between Model 410C circuit ground and earth ground terminals. Set dc voltmeter RANGE to 10 V.
- c. Set Model 410C FUNCTION SELECTOR to +DCV; RANGE to 1.5 V.
- d. Adjust Voltmeter Calibrator to provide +1.5 v.
- e. Model 410C and dc voltmeter should read 1.5 v.
- f. If dc voltmeter does not read at least 1.5 v, refer to Paragraph 5-37 for proper adjustment procedure.

#### 5-21. AMPLIFIER OUTPUT IMPEDANCE CHECK.

- a. Connect an external DC Voltmeter (hp Model 3440A/3441A) to Model 410C DC AMPLIFIER OUTPUT terminals on rear panel.
- b. Set Model 410C FUNCTION SELECTOR to OHMS position; RANGE to RX10K.
- c. Record voltage indicated on external dc voltmeter for use as a reference.
- d. Connect a 1.5 K ohm  $\pm 1\%$  resistor (hp Part No. 0730-0017) across Model 410C DC AMPLIFIER OUTPUT terminals. Dc voltage recorded in step c above should not change more than 3 mv, indicating that dc amplifier output impedance is within the 3 ohm specification at dc.

#### 5-22. AMPLIFIER NOISE CHECK.

- a. Connect external DC Voltmeter (hp Model 3440A/3441A) to the DC AMPLIFIER OUTPUT of Model 410C.
- b. Set the Model 410C FUNCTION SELECTOR to +DCV; RANGE to 1500 V.
- c. Short the Model 410C DCV and COM cables. External dc voltmeter reading should be less than 7.5 mv.
- d. Reset Model 410C RANGE to 1.5 V. DC Voltmeter should read less than 7.5 mv.

#### NOTE

If Model 410C DC OUTPUT is used for recording, the chopper frequency can be adjusted to minimize output noise. Refer to Paragraph 5-31.

#### 5-23. OVERLOAD RECOVERY CHECK.

- a. Connect Voltmeter Calibrator (hp Model 738BR) output to Model 410C DCV and COM cables.
- b. Set Model 410C FUNCTION SELECTOR to +DCV; RANGE to .15 V.
- c. Adjust voltmeter calibrator for +0.15 vdc; note reading on Model 410C.
- d. Readjust voltmeter calibrator for +15 VDC output; wait 5 seconds for complete saturation; then switch voltmeter calibrator back to +.15 VDC output. Note time required for meter to return to original position.
- e. Recovery time should be less than 3 sec.

#### 5-24. AC VOLTMETER OPERATION.



WHEN MEASURING AC VOLTAGES, DO NOT PERMIT AC GROUND JUMPER OF MODEL 410C AC PROBE TO CONTACT UN-GROUNDED SIDE OF AC SOURCE OR SERIOUS DAMAGE TO 410C WILL RESULT.

#### 5-25. AC VOLTMETER ACCURACY CHECK.

- a. Set Model 410C RANGE to 0.5 V. Short the input of the AC Probe. Adjust ZERO vernier for zero pointer deflection.
- b. Connect ACV probe to the Voltmeter Calibrator (hp Model 738BR).
- c. Adjust voltmeter calibrator for 400 cps-rms output.
- d. Set Model 410C FUNCTION SELECTOR to ACV; RANGE to 500 V.
- e. Adjust the voltmeter calibrator to settings listed in Table 5-5. Model 410C should indicate readings within limits specified. If not, refer to Paragraph 5-38 for corrective action. Record Model 410C reading with 0.3 v input.

#### NOTE

The frequency response tests are performed using reference voltage obtained with 0.3 v input.

Table 5-5. AC Accuracy Test

Model 410C Range	Voltmeter Calibrator 400 cps	Model 410C Readings
	Voltage Selector	
500 V	300	285 to 315 V
150 V	150	145 to 154.5 V
50 V	50	48.5 to 51.5 V
15 V	15	14.5 to 15.45 V
5 V	5	4.85 to 5.15 V
1.5 V	1.5	1.45 to 1.545 V
.5 V	.5	.485 to .515 V
.5 V	.3	.285 to .315 V

### 5-26. AC VOLTMETER LOW FREQUENCY RESPONSE CHECK.

- A Test Oscillator (-hp-Model 652A), a BNC-to-Binding Post Adaptor (-hp- Part No. 10110A) and a 50 ohm Feed-thru Termination (-hp- Part No. 11048B) are required for this check.
- Connect Model 410C as shown in Figure 5-3.
- Set Model 410C FUNCTION SELECTOR to ACV; RANGE to 0.5 V.
- Set Test Oscillator frequency to 400 cps, and adjust amplitude to give same 410C reading as recorded in Paragraph 5-25, step e, with 0.3 V input.
- Set Test Oscillator REF SET to convenient level.
- Adjust frequency of Test Oscillator to various cardinal points between 20 cps and 10 Mc, resetting amplitude to reference level set in step c for each frequency. Model 410C readings should be the same as the reading set at 400 cps in step d  $\pm 10\%$  from 20 cps to 100 cps, and  $\pm 2\%$  from 100 cps to 10 Mc.

### 5-27. AC VOLTMETER HIGH FREQUENCY RESPONSE-CHECK.

- A VHF Signal Generator (-hp- Model 608C), a UHF Signal Generator (-hp- Model 612A),

a Probe-T-Connector (-hp- Model 11042A), a Micropotentiometer (Ballantine Model 440), and a DC Voltmeter (-hp- Model 3440A/3441A) are required for this check. Figure 5-4 describes test arrangement to be used.

#### NOTE

The micropotentiometer must have the proper radial resistance and current rating to deliver 0.30 v at its output.

- Set UHF oscillator output to provide output to Model 410C reading recorded in Paragraph 5-25, step c, with .3 v input; frequency to 10 Mc. Record dc voltmeter reading for reference.
- Vary VHF oscillator frequency from 10 Mc to 480 Mc maintaining reference dc voltmeter reading by readjusting VHF oscillator output. Model 410C reading should be the same as the reading set at 400 cps in Paragraph 5-26, step d,  $\pm 2\%$  at frequencies to 100 Mc, and  $\pm 10\%$  at all higher frequencies.
- Replace VHF oscillator with UHF oscillator in Figure 5-4. Repeat steps b and c for UHF oscillator output frequencies from 480 Mc to 700 Mc.

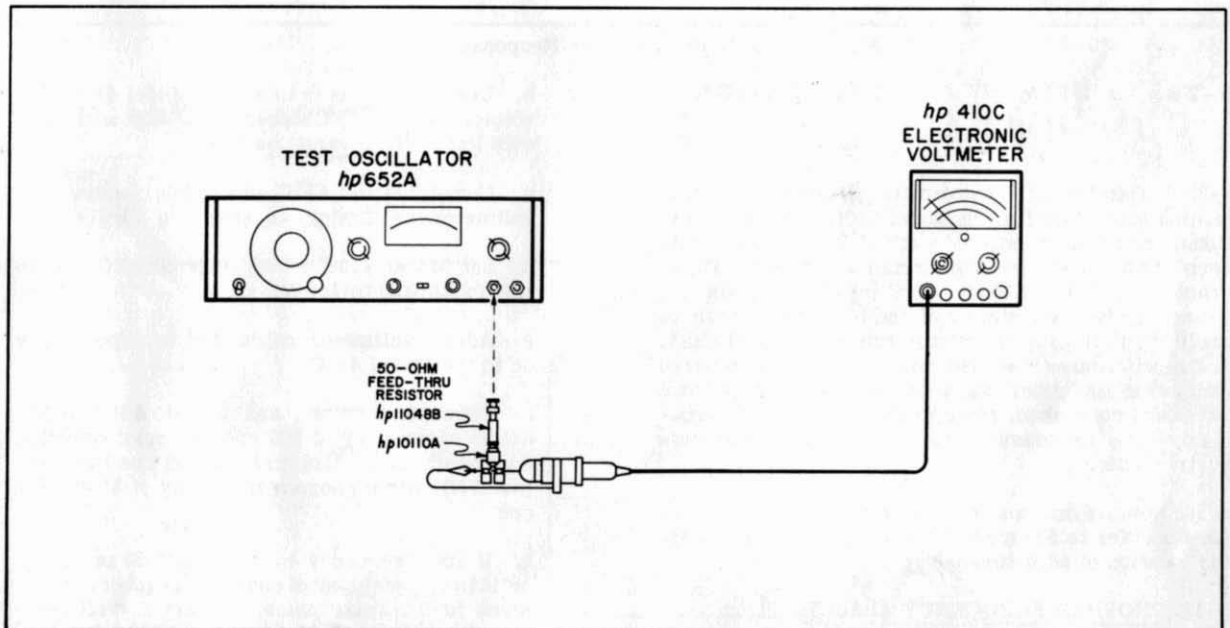

Figure 5-3. Low Frequency Response Test

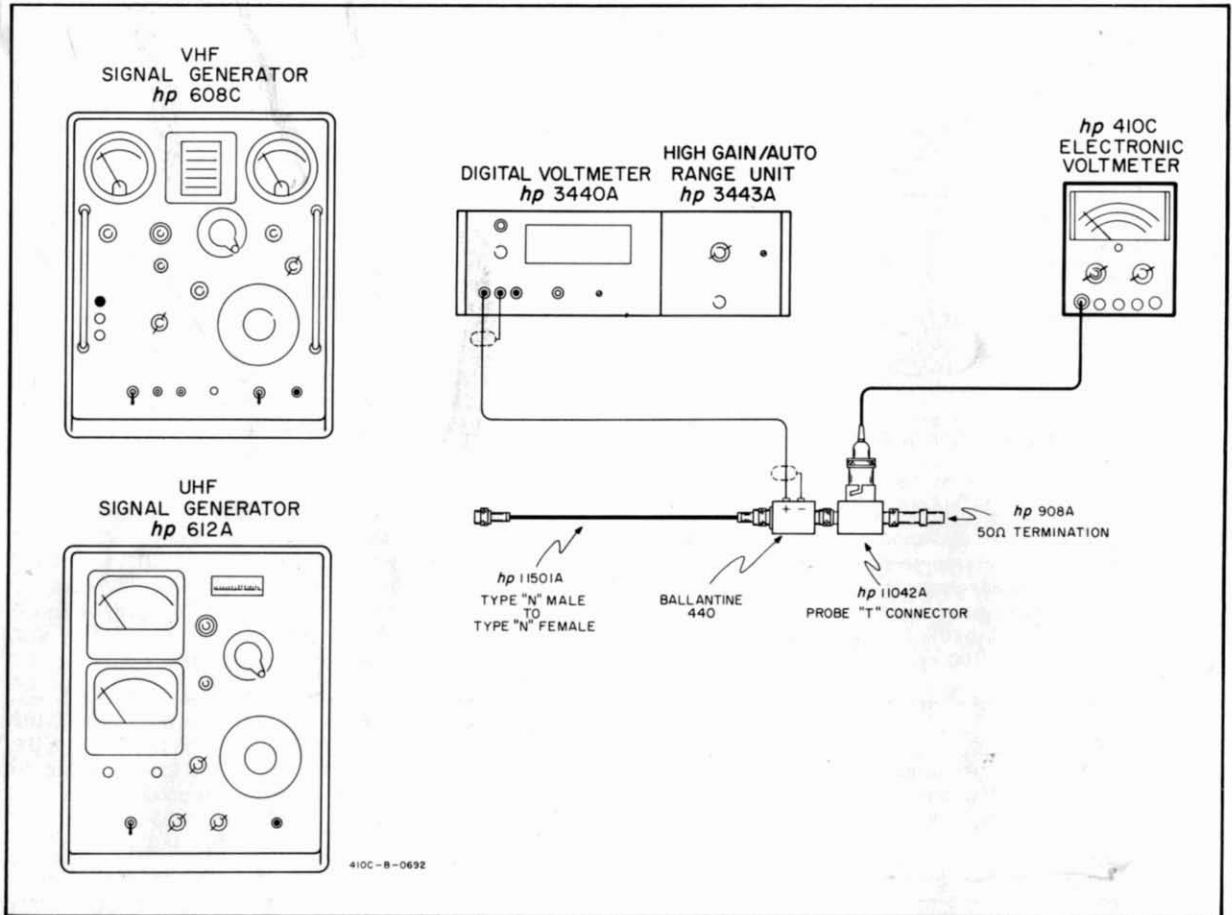

Figure 5-4. High Frequency Response Test

**5-28. ADJUSTMENT AND CALIBRATION PROCEDURE.**

5-29. The following is a complete adjustment and calibration procedure for the Model 410C. These operations should be conducted only if it has previously been established by Performance Checks, Paragraph 5-5, that the Model 410C is out of adjustment. Indiscriminate adjustment of the internal controls to "refine" settings may actually cause more difficulty. If the procedures outlined do not rectify any discrepancy that may exist, and all connections and settings have been rechecked, refer to Paragraph 5-41, Troubleshooting, for possible cause and recommended corrective action.

5-30. Remove top and bottom covers and two side panels; refer to Figure 5-5 throughout this procedure for location of adjustments.

**5-31. CHOPPER FREQUENCY ADJUST.**

a. A Voltmeter Calibrator (hp Model 738BR), an Electronic Counter (hp Model 5211A), and an AC Voltmeter (hp Model 3400A) will be required for this operation.

b. Use ac voltmeter to verify Model 410C line voltage of 115 v. Chopper frequency will vary with line voltage variations.

c. Connect Model 410C, electronic counter, and voltmeter calibrator as shown in Figure 5-6.

d. Set Model 410C FUNCTION SELECTOR to +DCV; RANGE to 1.5 V.

e. Adjust voltmeter calibrator to supply +5 v dc to the Model 410C.

f. Observe counter, and adjust A3R5 for a chopper frequency of 100 cps ( $\pm 2$  cps) if operated on a 60 cps line. If operated on 50 cps line, adjust A3R5 for a chopper frequency of 85 cps ( $\pm 2$  cps)

g. If line frequency is other than 50 or 60 cps or if fine adjustment of chopper frequency is desired to minimize noise, connect ac voltmeter with RANGE for 0.01 V to Model 410C DC Amplifier OUTPUT.

h. Adjust A3R5 to give minimum voltage reading on ac voltmeter.

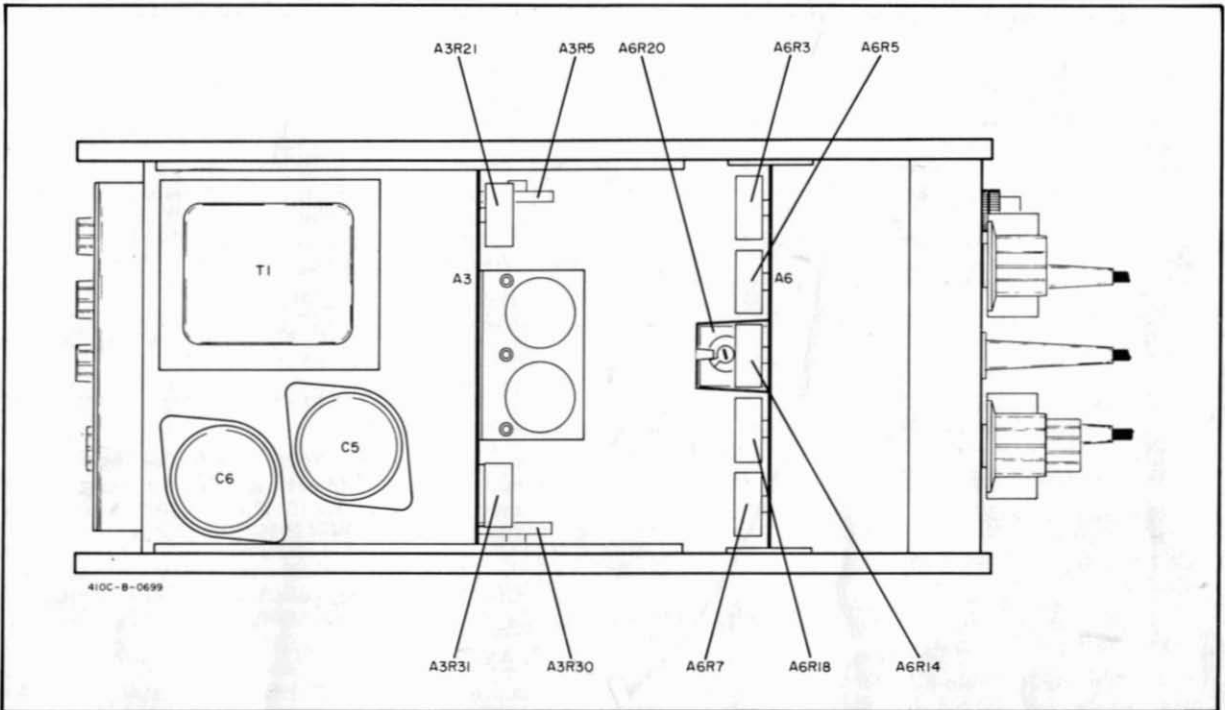

Figure 5-5. Adjustment Location

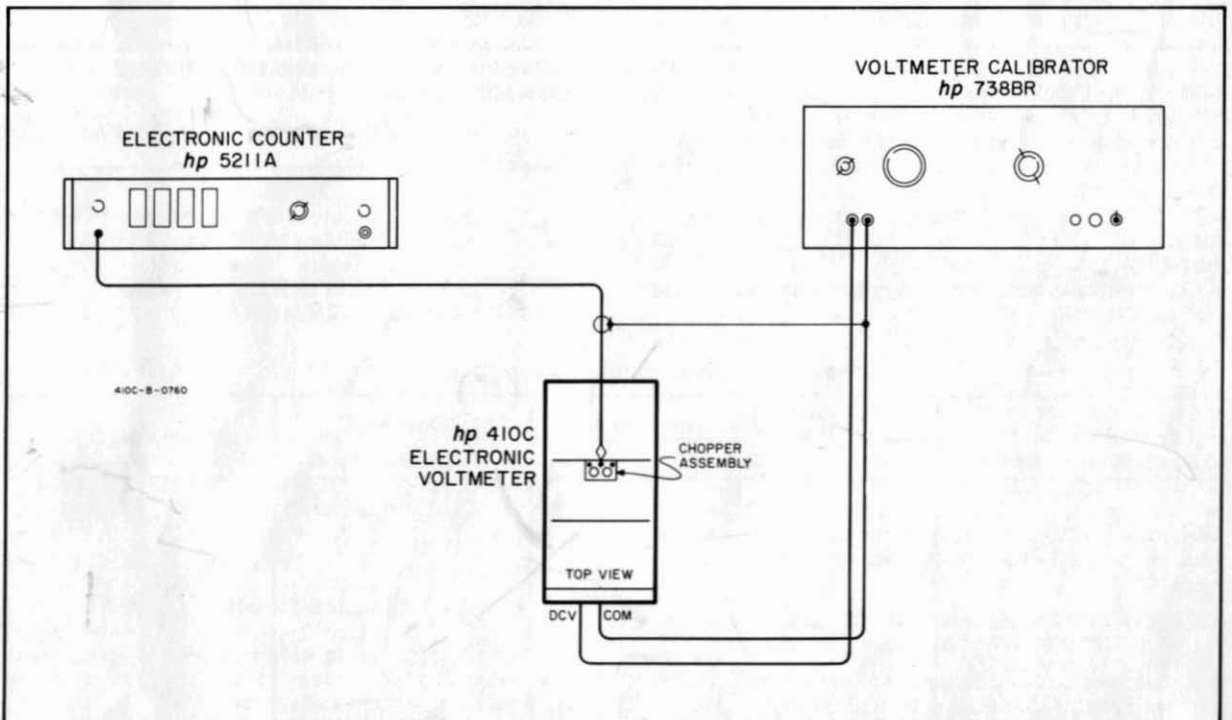

Figure 5-6. Chopper Frequency Adjust Setup

5-32. POWER SUPPLY CHECK.

a. Refer to Table 5-6 and Figure 5-8 for Power Supply check points and typical voltage values. Measure dc voltages between COM lead and designated location on A7.

Table 5-6. Power Supply Test

Voltage	Location on A7 (Figure 5-8)	Tolerance
+175 V	903	±30 V
+38 V	Junction of CR6 and R4	±8.0 V
+6 V	926	±0.6 V
-9 V	Junction of CR7 and R7	±1.8 V

b. Measure +175 volt ac ripple across 903 and COM with ac voltmeter (Ⓢ Model 3400A). RMS value of ripple should not exceed 5.0 mv.

5-33. DC VOLTMETER CALIBRATION.

5-34. DC ZERO ADJUSTMENT AND BIAS.

a. Set Model 410C Function Selector to +DCV and Range Switch to 0.5 V.

b. Short DCV Cable to COM Cable.

c. Adjust A3R21 fully counterclockwise, then rotate about 20 degrees clockwise.

d. Adjust ZERO ADJ on rear panel for zero meter deflection. Switch to -DCV. If any deflection is observed, adjust ZERO ADJ to return meter pointer halfway back to zero. Check zero setting on all ranges for both +DCV and -DCV. Zero offset shall not exceed 1% in any case.

5-35. DC FULL SCALE ADJUST.

a. Connect Model 410C DCV and COM cables to Voltmeter Calibrator (Ⓢ Model 738BR) output terminals.

b. Set Model 410C FUNCTION SELECTOR to the +DCV position; RANGE switch to 0.015 V.

c. Adjust voltmeter calibrator to settings listed in Table 5-7.

d. Select proper A6R18 setting which will provide best overall full scale readings for 0.015 V, 0.05 V, and 0.15 V ranges. Adjust A3R30 for best overall full scale readings for ranges above 0.15 V.

NOTE

A6R18 must be adjusted before A3R30, because A6R18 affects all ranges and A3R30 only affects ranges above 0.15 V.

5-36. OHMMETER CALIBRATION.

a. Set Model 410C FUNCTION SELECTOR to OHMS; RANGE to RX10M.

b. Short OHMS and COM cables. Model 410C should read zero.

c. Vary Model 410C RANGE switch through remainder of OHMS settings. Meter should read zero, except at RX10 when meter should read about 0.1 ohms (resistance of leads).

d. Disconnect OHMS and COM cables. Set OHMS ADJ (rear panel) for ∞ reading. Check ∞ reading on all OHMS RANGE settings.

5-37. AMPLIFIER OUTPUT CALIBRATION.

a. A Voltmeter Calibrator (Ⓢ Model 738BR) and a DC Voltmeter (Ⓢ Model 3440A/3441A) is required for this calibration.

b. Set Model 410C FUNCTION SELECTOR to +DCV; RANGE to 5 V.

c. Adjust voltmeter calibrator to provide 5 V. Set dc voltmeter RANGE to 10 V.

d. Connect Model 410C DCV probe and COM lead to output of voltmeter calibrator. Connect dc voltmeter to dc amplifier OUTPUT on Model 410C rear panel.

e. Adjust A6R20 to give 1.5 v reading on dc voltmeter.

NOTE

Amplifier output will provide a negative voltage for all negative dc and ac inputs. The AC Probe is designed to provide a negative dc voltage to Model 410C.

Table 5-7. DCV Calibration Procedure

Model 410C Range Settings	Voltmeter Calibrator Settings		Model 410C Meter Readings	Adjustment
	Voltage			
.015 V	.015		.0147 to .0153 V	A6R18
.05 V	.05		.049 to .051 V	A6R18
.15 V	.15		.147 to .153 V	A6R18
.5 V	.5		.49 to .51 V	A3R30
1.5 V	1.5		1.47 to 1.53 V	A3R30
5 V	5		4.9 to 5.1 V	A3R30
15 V	15		14.7 to 15.3 V	A3R30
50 V	50		49 to 51 V	A3R30
150 V	150		147 to 153 V	A3R30
500 V	300		290 to 310 V	A3R30
1500 V	300		270 to 330 V	A3R30

5-38. AC VOLTMETER CALIBRATION.

## 5-39. AC ZERO ADJUST.

- Set Model 410C FUNCTION SELECTOR to ACV; RANGE to 0.5 V. Ensure full insertion of telephone plug from ac probe into Model 410C.
- Set AC ZERO vernier on front panel to center of rotation.
- Short Model 410C ac probe and ac probe common (short lead).
- Adjust A3R31 for Model 410C approximately zero deflection.
- Fine adjust AC ZERO vernier for Model 410C zero deflection.

## 5-40. AC FULL SCALE ADJUST.

**CAUTION**

WHEN MEASURING AC VOLTAGES, DO NOT PERMIT AC GROUND JUMPER OF MODEL 410C AC PROBE TO CONTACT UNGROUNDED SIDE OF AC SOURCE OR SERIOUS DAMAGE TO 410C WILL RESULT.

- Connect Model 410C ac probe to voltmeter calibrator output terminals. Set Model 410C FUNCTION SELECTOR to ACV; RANGE to 0.5 V.
- Adjust voltmeter calibrator to settings listed in Table 5-8 at 400 cps-rms output.
- Adjust potentiometers called for under "Adjustment" to provide Model 410C readings listed.

Table 5-8. AC Full Scale Adjust

Model 410C Range	Voltmeter Calibrator AC Voltage Settings	Model 410C Reading $\pm 3\%$	Adjustment
.5 V	.50	.5 V	A6R3
1.5 V	1.5	1.5 V	A6R5
5 V	5	5 V	A6R7
* 15 V	15	15 V	A6R14
* 50 V	50	50 V	A6R14
* 150 V	150	150 V	A6R14
* 500 V	300	300 V	A6R14

\* A6R14 is proper adjustment of Model 410C for RANGE settings from 15 vac to 500 vac. Select proper A6R14 setting which will provide best overall results for these ranges.

## 5-41. TROUBLESHOOTING PROCEDURE.

5-42. This section contains procedures designed to assist in the isolation of malfunctions. These procedures are based on a systematic analysis of the instrument circuitry in an effort to localize the problem. These operations should be undertaken only

after it has been established that the difficulty cannot be eliminated by the Adjustment and Calibration Procedures, Paragraph 5-28. An investigation should also be made to insure that the trouble is not a result of conditions external to the Model 410C.

5-43. Conduct a visual check of the Model 410C for possible burned or loose components, loose connections, or any other obvious conditions which might suggest a source of trouble.

5-44. Table 5-9 contains a summary of the front-panel symptoms that may be encountered. It should be used in initial efforts to select a starting point for troubleshooting operations.

5-45. Figure 5-7 contains procedures which may be used as a guide in isolating malfunctions.

5-46. The checks outlined in Figure 5-7 are not designed to measure all circuit parameters, rather only to localize the malfunction. Therefore, it is quite possible that additional measurements will be required to completely isolate the problem. Amplifier gain may also vary slightly between instruments; therefore it should not be necessary to precisely duplicate waveforms or values described.

5-47. Refer to Figure 5-10 for typical waveforms encountered in the Model 410C. Waveforms represent signals which occur when instrument is operating during overdriven conditions (0.5 vdc input to 0.015 v RANGE).

5-48. SERVICING ETCHED CIRCUIT BOARDS.

5-49. The  $\text{hp}$  Model 410C has three etched circuit boards. Use caution when removing them to avoid damaging mounted components. The  $\text{hp}$  Part Number for the assembly is silk screened on the interior of the circuit board to identify it. Refer to Section VI for parts replacement and  $\text{hp}$  Part Number information.

5-50. The etched circuit boards are a plated-through type. The electrical connection between sides of the board is made by a layer of metal plated through the component holes. When working on these boards, observe the following general rules.

- Use a low-heat (25 to 50 watts) small-tip soldering iron, and a small diameter rosin core solder.

- Circuit components can be removed by placing the soldering iron on the component lead on either side of the board, and pulling up on lead. If a component is obviously damaged, clip leads as close to component as possible and then remove. Excess heat can cause the circuit and board to separate, or cause damage to the component.

- Component lead hole should be cleaned before inserting new lead.

- To replace components, shape new leads and insert them in holes. Reheat with iron and add solder as required to insure a good electrical connection.

- e. Clean excess flux from the connection and adjoining area.
- f. To avoid surface contamination of the printed

circuit, clean with weak solution of warm water and mild detergent after repair. Rinse thoroughly with clean water. When completely dry, spray lightly with Krylon (#1302 or equivalent).

Table 5-9. Front Panel Troubleshooting Procedure

FRONT PANEL SYMPTOM	POSSIBLE CAUSE
No meter deflection with input. ON - OFF lamp not glowing.	Check fuse (F1) on back panel.
In -DCV, pointer deflects 1/2 scale. In +DCV, pointer pegs downscale.	Check A3C5 (Figure 5-11).
In +DCV, pointer pegs downscale. In -DCV, pointer pegs upscale.	Check A3Q1, A3C6 or A3C12 (Figure 5-11).
Excessive jitter. Ohms function; all ranges except RX10M.	Check A2R2 (Figure 4-5).
*DCA mode out on 50 ma and 150 ma ranges.	Check A2R25 and A2R26 (Figure 4-3).
*If $\infty$ ADJ is effective in ranges from RX10 to RX1M, then shifts when RANGE switch is set to RX10M.	Check A2R2 (Figure 4-5).
*AC ZERO will not adjust properly. Pointer responds to input variations.	Check A1R5, A1R6, A1R7 and A3R31 (Figure 4-6).
*Operates in DCV mode on ranges 0.015 v to 0.15 v, but fails on higher ranges.	Check A2R2 and A3R30.
Dc amplifier output is +1.5 v. Meter will not deflect full scale in DCV or DCA mode.	Check A6R21, A6R20, A6R1, A6R18 and A6R17 (Figure 4-4).
*Meter pegs upscale on all ranges. +DC Amplifier output is high regardless of mode of operation.	Check for open resistor in amplifier feedback loop or shorted A1R10 (Figure 5-11).
In ACV mode, pointer will not deflect full scale with proper input applied.	Refer to Paragraph 5-38.
Operates on all ranges in ACV mode except 5 v ac position.	Check A6R16 and A6CR1 (Figure 4-6).
Instrument inoperative in all modes. Meter has slight random drift pattern.	Check chopper assembly. Connect 1M ohm resistor across A3A1V1. If photocell were open, meter will now respond to input. Use 100 K resistor across A3A1V3 to check DC - Modulator (Figure 5-10).
Meter oscillates full scale at rate of 5 - 10 cps.	Check chopper assembly. Connect 1M ohm resistor across A3A1V2. If photocell were open, instrument will now respond to input. Use 100 K resistor across A3A1V2 to check DC - Modulator (Figure 5-10).
No ac zero.	Check C1 for short to chassis (Figure 4-6). Check ac probe.
No deflection on OHMS; dc ranges operative.	Check OHMS and DCA lead for short to common at alligator clip.
0.5 and 1.5 VAC range will not track.	Check A8V1 (Figure 5-13). Substitute known good ac probe.
5 VAC range will not track.	Check A6CR1.

\* Refer to ⑥, Table 5-7.



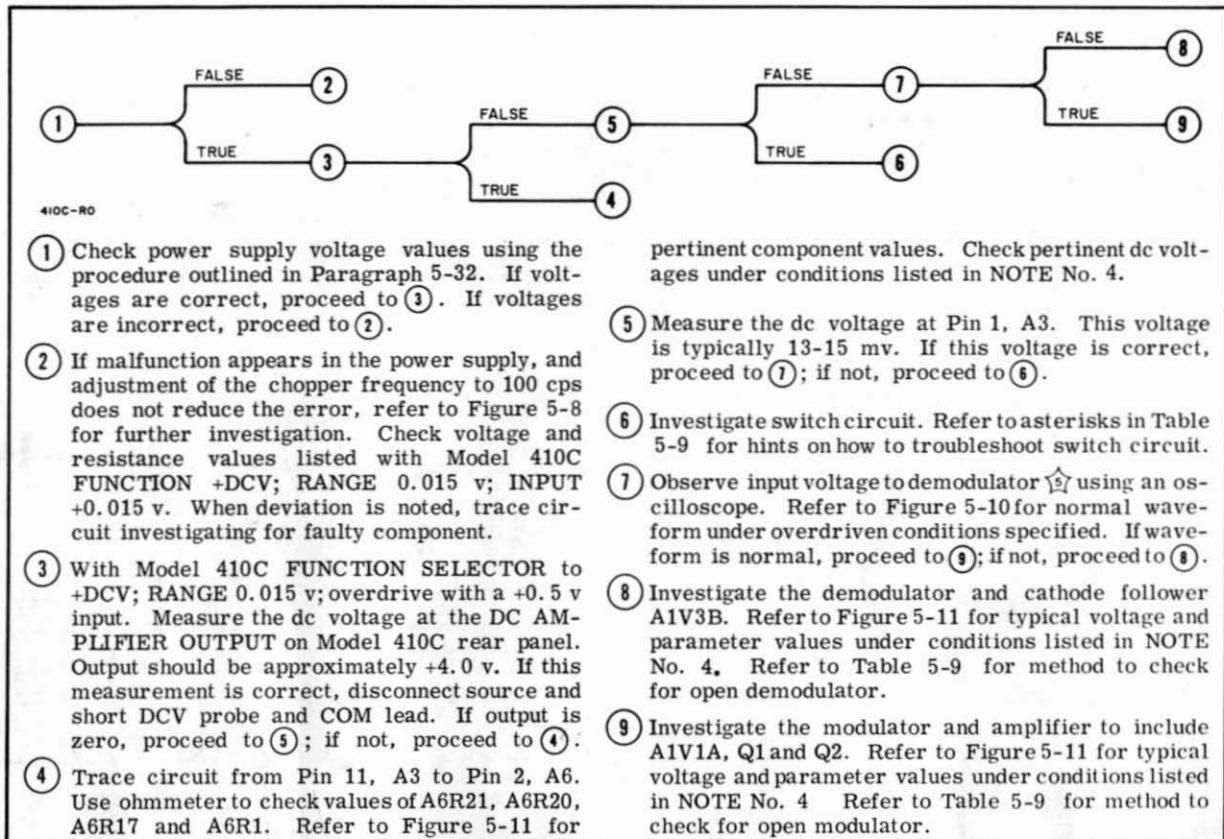

Figure 5-7. Troubleshooting Procedures

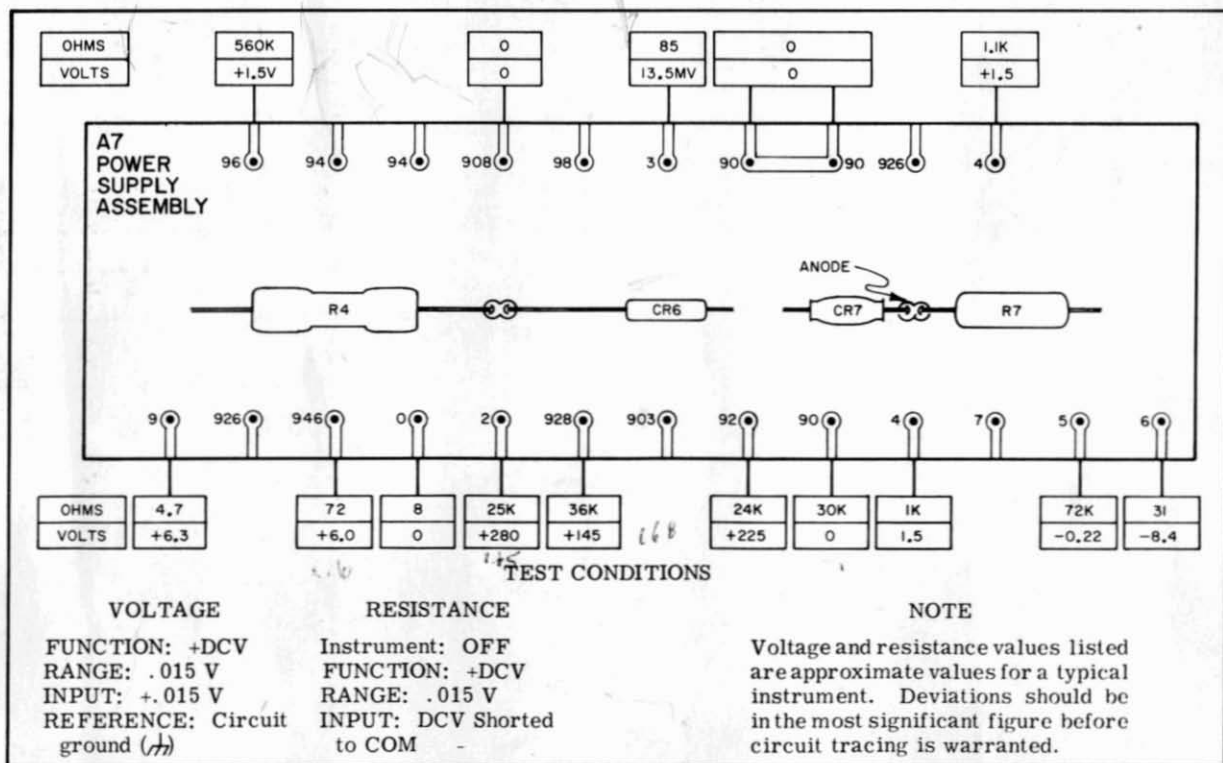







Figure 5-8. Power Supply Measurements

NOTES

1.  INDICATES AN ASSEMBLY. ALL COMPONENTS LOCATED ON AN ASSEMBLY ARE PREFIXED BY THE ASSEMBLY DESIGNATION (e.g., R3 ON ASSEMBLY A7 BECOMES A7R3).
2. UNLESS OTHERWISE INDICATED:  
RESISTANCE IS IN OHMS.  
CAPACITANCE IS IN MICROFARADS.
3.  = CABINET GROUND.  = CIRCUIT GROUND (FLOATING).
4.  DENOTES WIRE COLOR USING STANDARD COLOR CODE. (e.g. 9 = WHITE, 8 = GRAY, 0 = BLACK.)
5.  INDICATES FRONT PANEL LOCATION.  
 INDICATES REAR PANEL LOCATION.

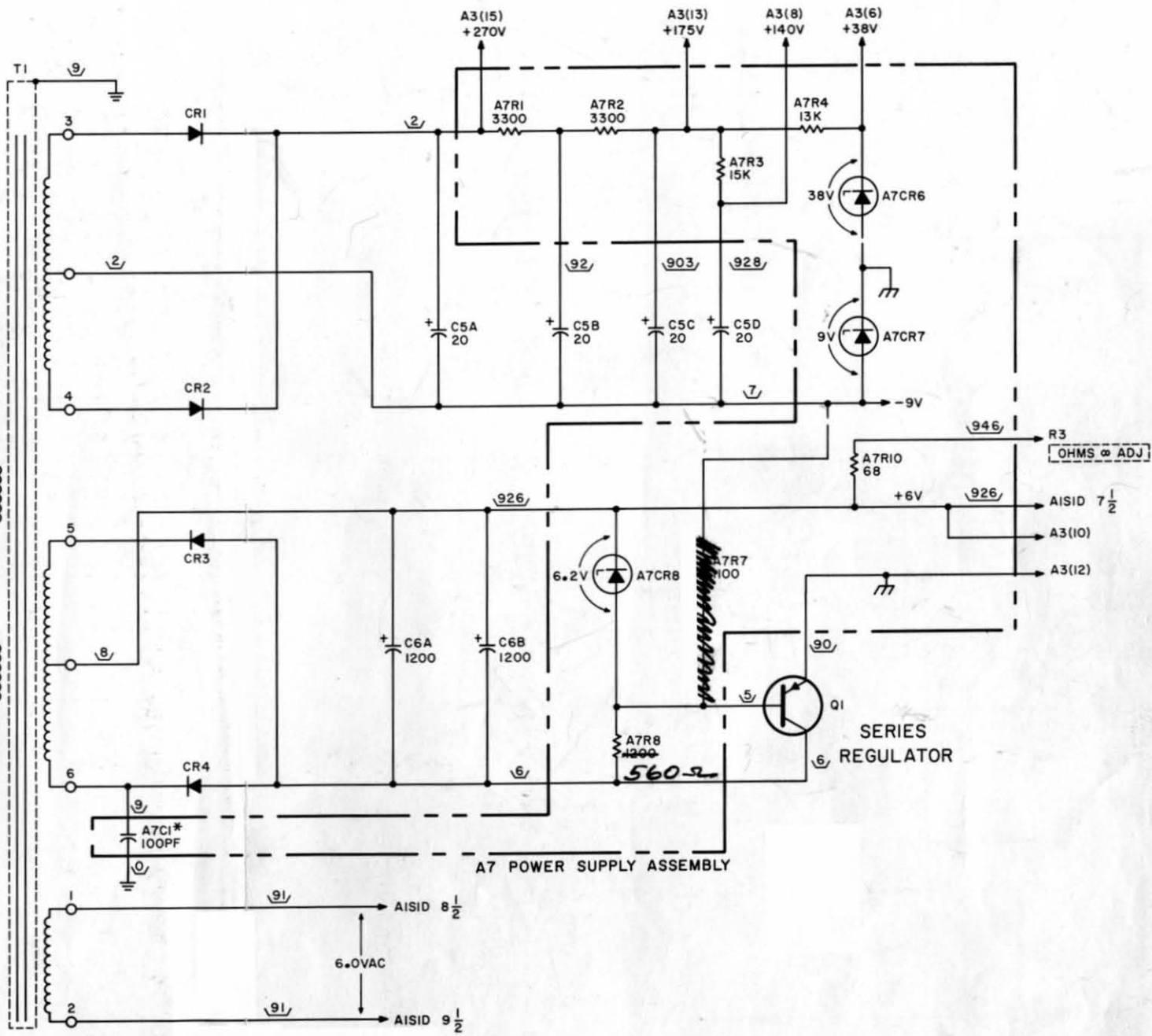
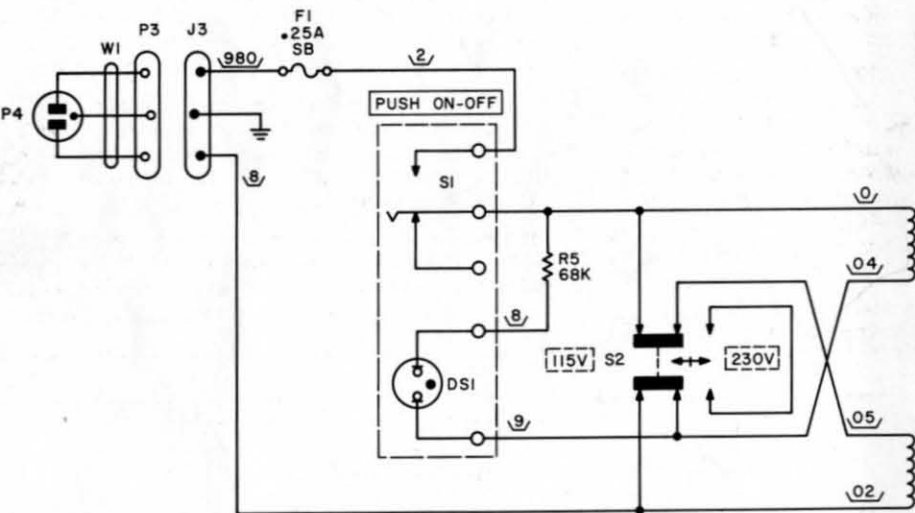
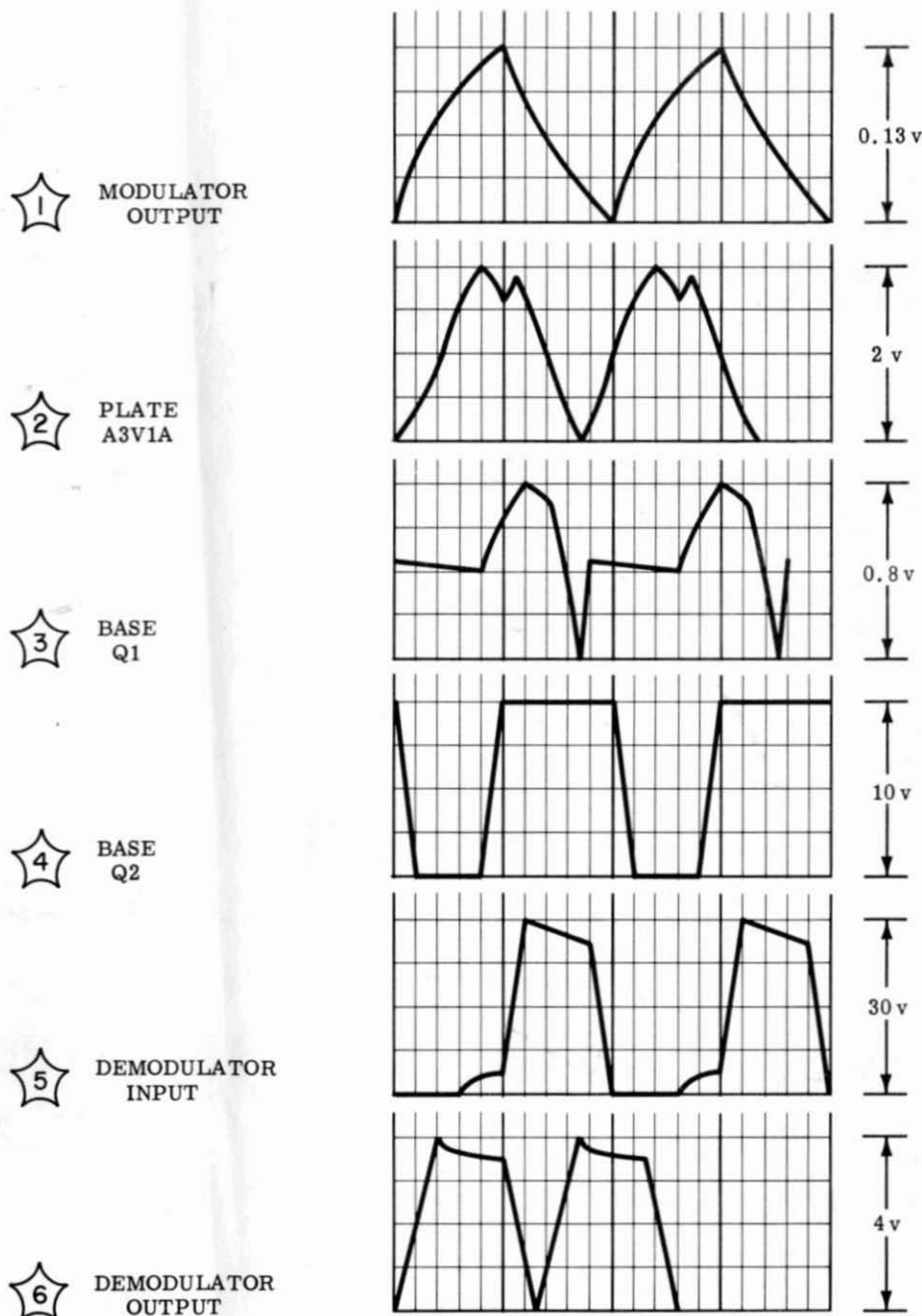

Figure 5-9. Power Supply Schematic











TEST CONDITIONS:  
 FUNCTION: +DCV  
 RANGE: .015 V  
 INPUT: +0.5 V

Waveforms observed on  
 Model 175A w/ Model  
 1752A and 1780A Plug-ins  
 and 10001A Voltage Di-  
 vider Probe using circuit  
 ground (⌚) as referenced.

410C-B-0183

Figure 5-10. Typical Amplifier Waveforms

## NOTES

1. A3A1V1 AND A3A1V3 ARE LIGHTED SIMULTANEOUSLY BY A3A1DS1, AND A3A1V2 AND A3A1V4 ARE LIGHTED BY A3A1DS2.
2. UNLESS OTHERWISE NOTED:  
RESISTANCE IS IN OHMS.  
CAPACITANCE IS IN MICROFARADS.
3. SWITCHES ARE SHOWN IN FULL CCW POSITIONS.
4. DC VOLTAGES SHOWN ARE TYPICAL UNDER THE FOLLOWING CONDITIONS:  
FUNCTION: +DCV  
RANGE: 1.5 V  
INPUT: +1.5 V
5.  INDICATES AN ASSEMBLY. ALL COMPONENTS LOCATED ON AN ASSEMBLY ARE PREFIXED BY THE ASSEMBLY DESIGNATION (e. g. , R3 ON ASSEMBLY A7 BECOMES A7R3.)
6.  INDICATES SUBASSEMBLY.
7.  INDICATES DC FEEDBACK.
8. P/O = PART OF.
9.  INDICATES FRONT PANEL LOCATION.  
 INDICATES REAR PANEL LOCATION.
10.  INDICATES PANEL ADJUST.  
 INDICATES SCREWDRIVER ADJUST.
11.  = CABINET GROUND.  
 = CIRCUIT GROUND (FLOATING).
12. 935 DENOTES WIRE COLOR USING STANDARD COLOR CODE. (e. g. 9 = WHITE, 3 = ORANGE, 5 = GREEN.)
13. \* = OPTIMUM VALUE SELECTED AT FACTORY, AVERAGE VALUE SHOWN.
14. † VOLTAGE IS DEPENDENT ON LOAD INTRODUCED BY EXTERNAL VOLTMETER.
15. + VOLTAGE VARIES ACCORDING TO INDIVIDUAL TUBE.
16. †† PIN 8 IS REFERENCE. VOLTAGE VARIES ACCORDING TO INDIVIDUAL TUBE.

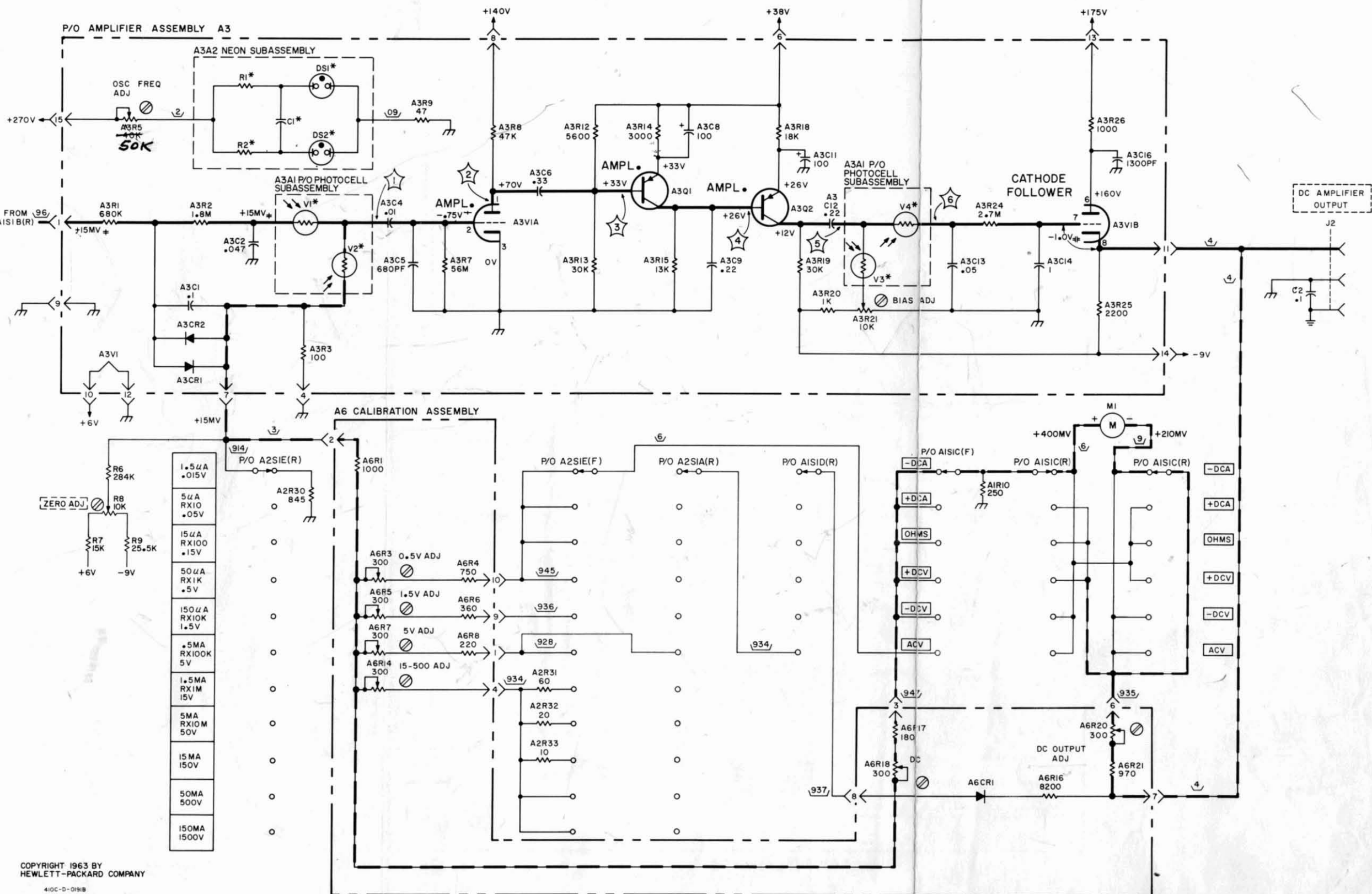

COPYRIGHT 1963 BY  
HEWLETT-PACKARD COMPANY  
410C-D-0191B

Figure 5-11. Amplifier Schematic

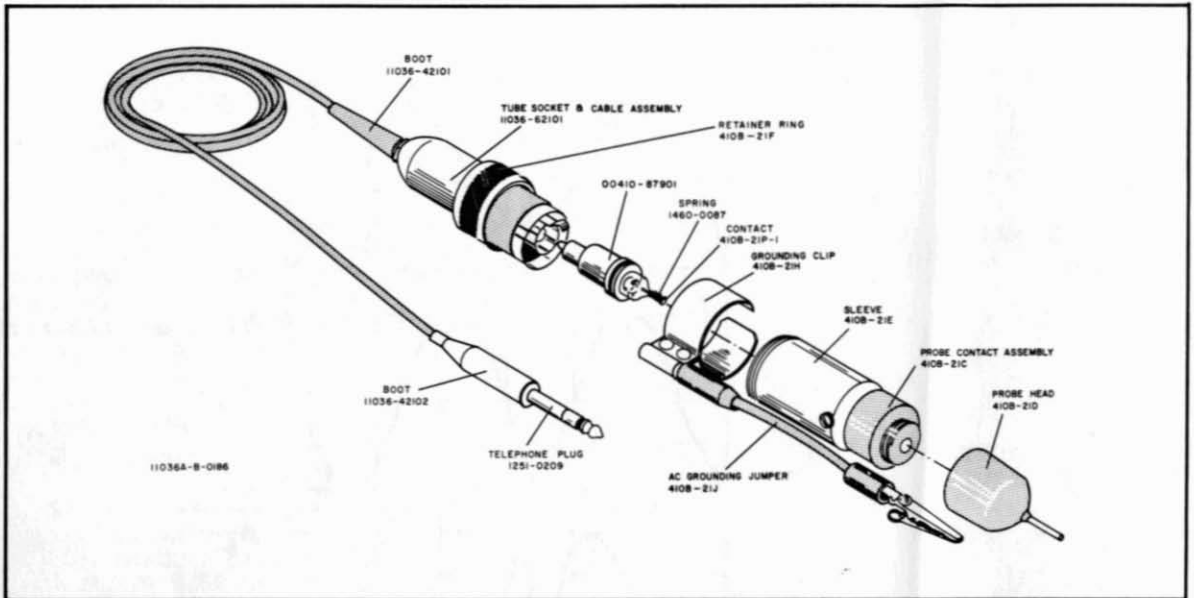

Figure 5-12. Model 11036A AC Probe (Exploded View)

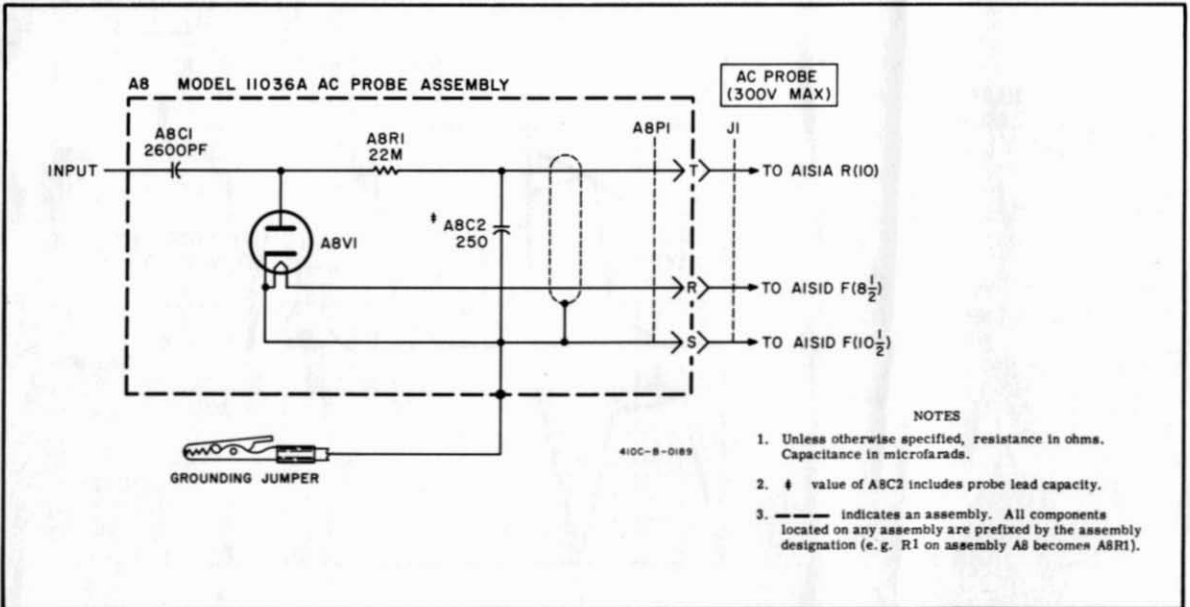

Figure 5-13. Model 11036A AC Probe Schematic

NOTES

- SWITCHES ARE SHOWN IN FULL CCW POSITIONS.
- P/O = PART OF.
- CAPACITANCE IN MICROFARADS AND RESISTANCE IN OHMS, UNLESS OTHERWISE SPECIFIED.
- $\perp$  = EARTH GROUND;  $\text{---}$  = CIRCUIT COMMON.
- $\text{---}$  INDICATES CIRCUIT GROUND BUSS.
- $\bigcirc$  INDICATES PANEL ADJUST;  $\text{---}$  INDICATES SCREW-DRIVER ADJUST.
- $\text{---}$  INDICATES WIRE COLOR USING STANDARD COLOR CODE. (e.g., 9 = WHITE, 3 = ORANGE, 7 = VIOLET.)
- \* OPTIMUM VALUE SELECTED AT FACTORY. AVERAGE VALUE SHOWN.
- $\text{---}$  INDICATES FRONT PANEL LOCATION  
 $\text{---}$  INDICATES REAR PANEL LOCATION.

AISIA

AISIB

AISIC

AISID

WAFFER FRONT  
VIEWED FROM FRONT OF INSTRUMENT

WAFFER FRONT  
VIEWED FROM FRONT OF INSTRUMENT

WAFFER REAR  
VIEWED FROM FRONT OF INSTRUMENT

WAFFER REAR  
VIEWED FROM FRONT OF INSTRUMENT

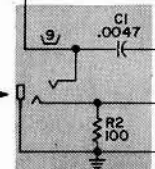
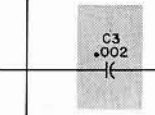
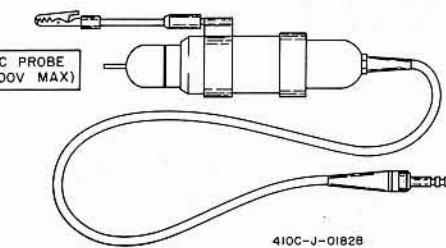
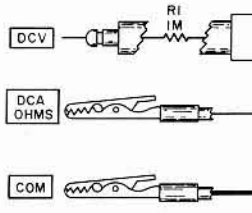
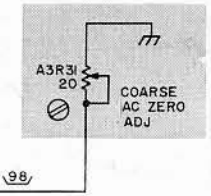
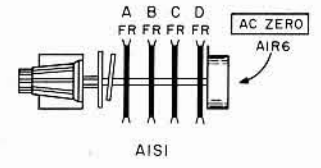
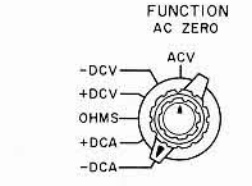
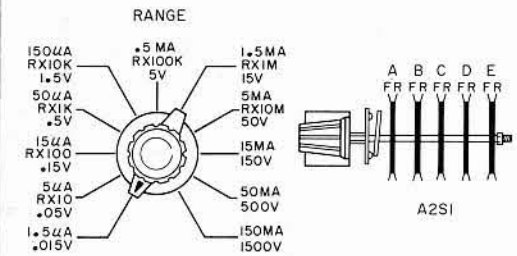
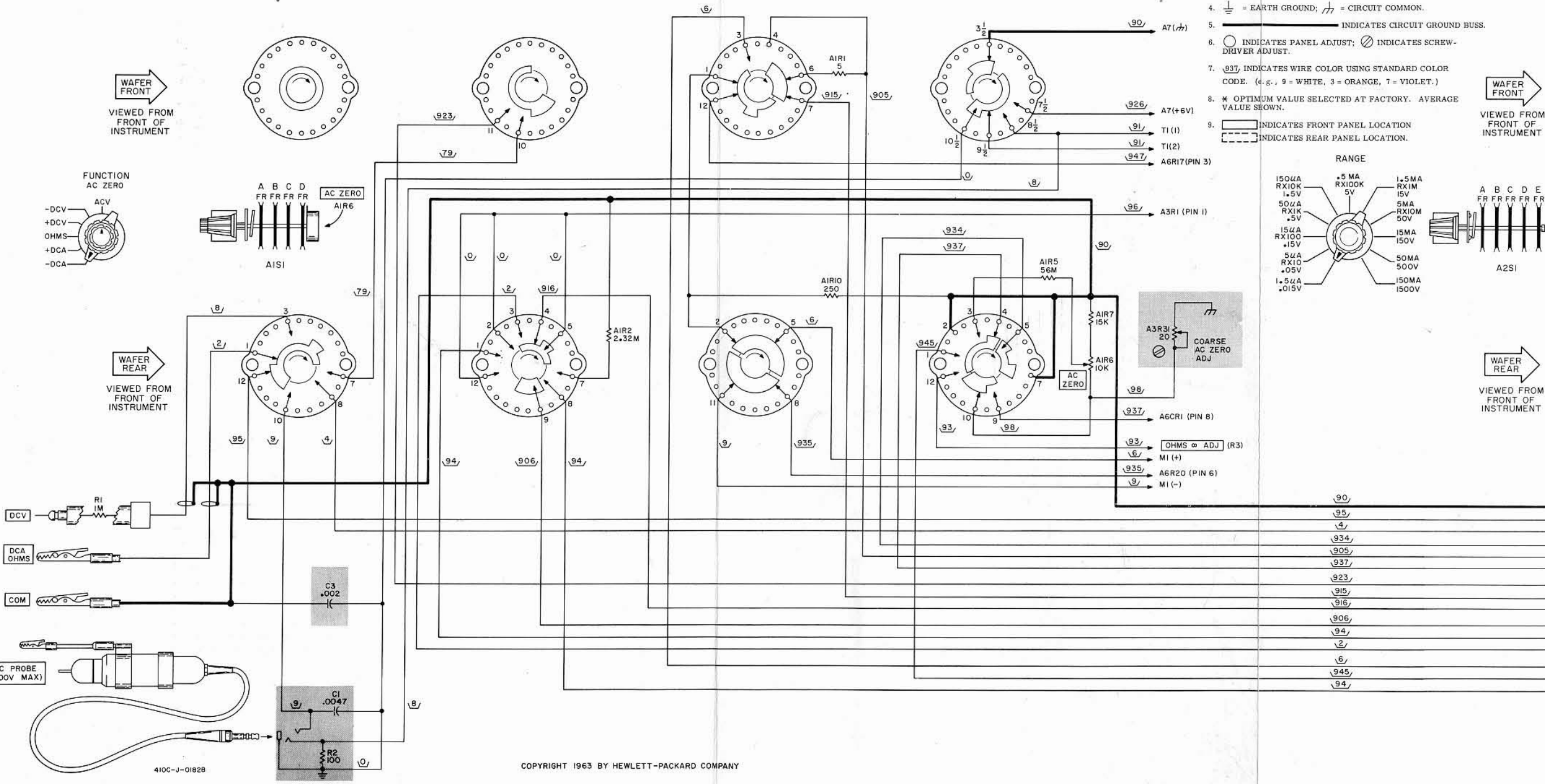

NOTES

- 1. SWITCHES ARE SHOWN IN FULL CCW POSITIONS.
- 2. P/O = PART OF.
- 3. CAPACITANCE IN MICROFARADS AND RESISTANCE IN OHMS, UNLESS OTHERWISE SPECIFIED.
- 4.  $\perp$  = EARTH GROUND;  $\text{---}$  = CIRCUIT COMMON.
- 5.  $\text{---}$  INDICATES CIRCUIT GROUND BUSS.
- 6.  $\bigcirc$  INDICATES PANEL ADJUST;  $\text{---}$  INDICATES SCREW-DRIVER ADJUST.
- 7.  $\text{---}$  INDICATES WIRE COLOR USING STANDARD COLOR CODE. (e.g., 9 = WHITE, 3 = ORANGE, 7 = VIOLET.)
- 8. \* OPTIMUM VALUE SELECTED AT FACTORY. AVERAGE VALUE SHOWN.
- 9.  $\text{---}$  INDICATES FRONT PANEL LOCATION  
 $\text{---}$  INDICATES REAR PANEL LOCATION.

WAFFER FRONT  
VIEWED FROM FRONT OF INSTRUMENT

WAFFER REAR  
VIEWED FROM FRONT OF INSTRUMENT

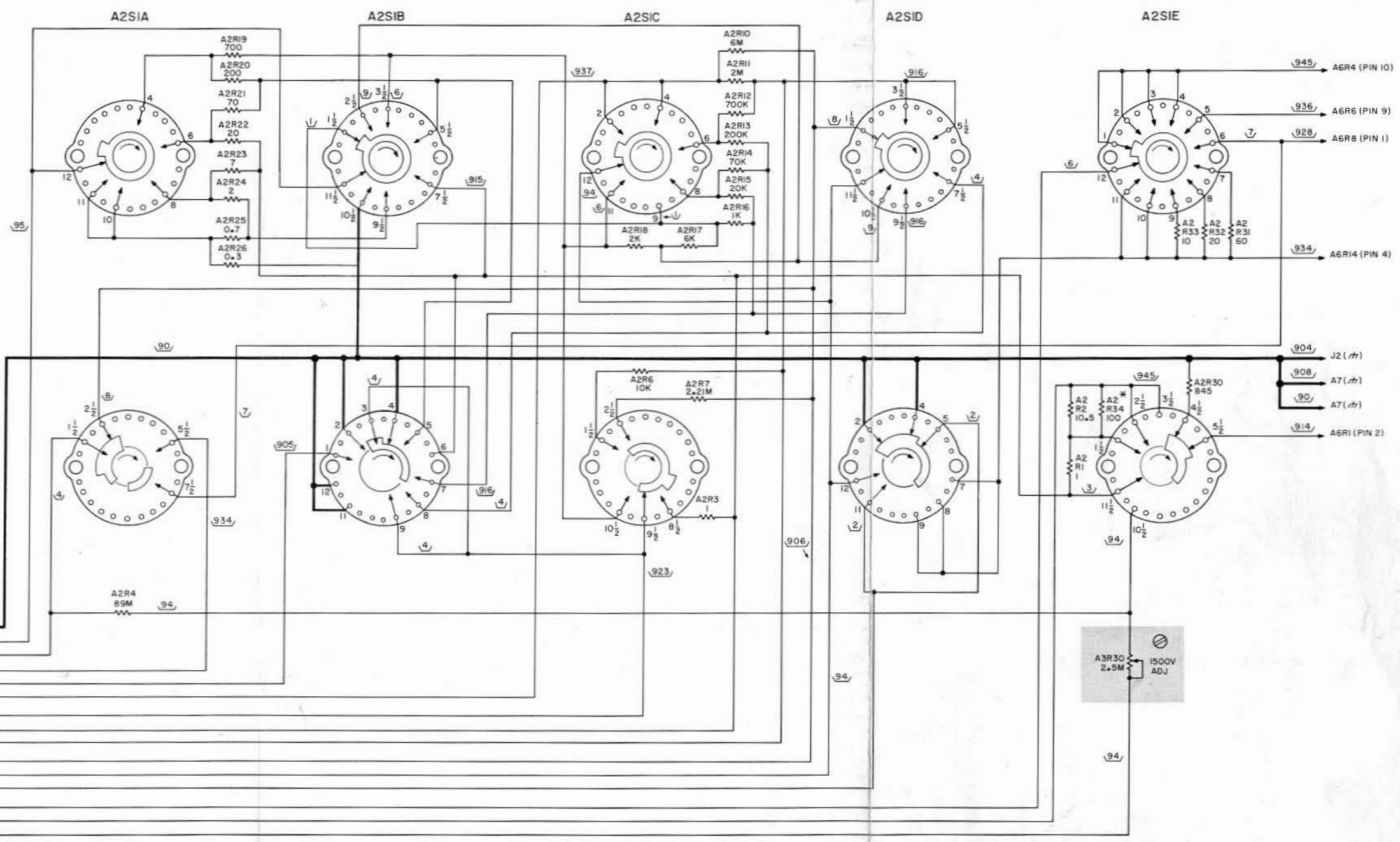
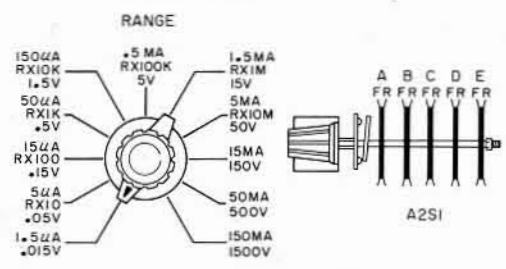
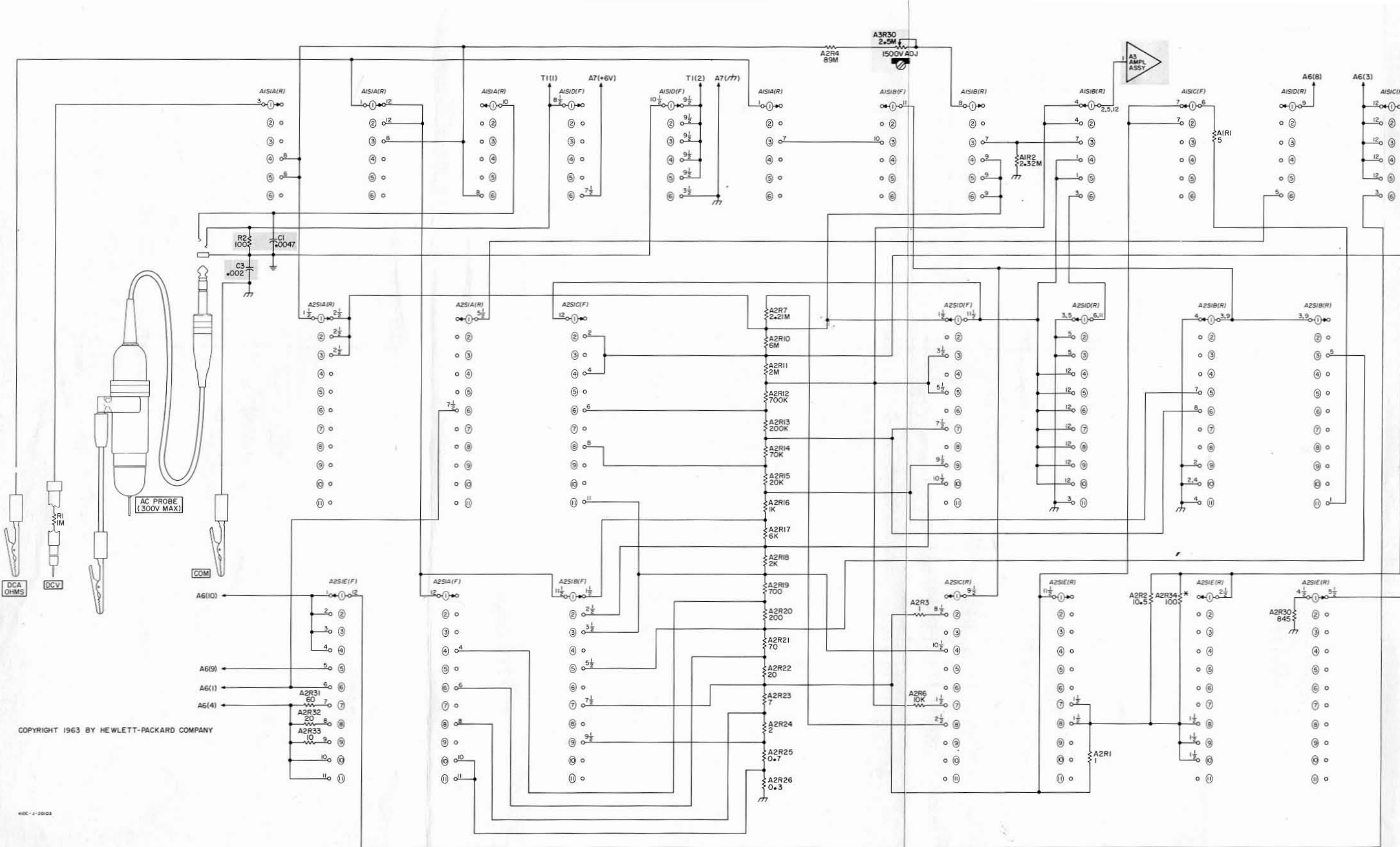

Figure 5-14. RANGE and FUNCTION Switching (Pictorial)





COPYRIGHT 1963 BY HEWLETT-PACKARD COMPANY

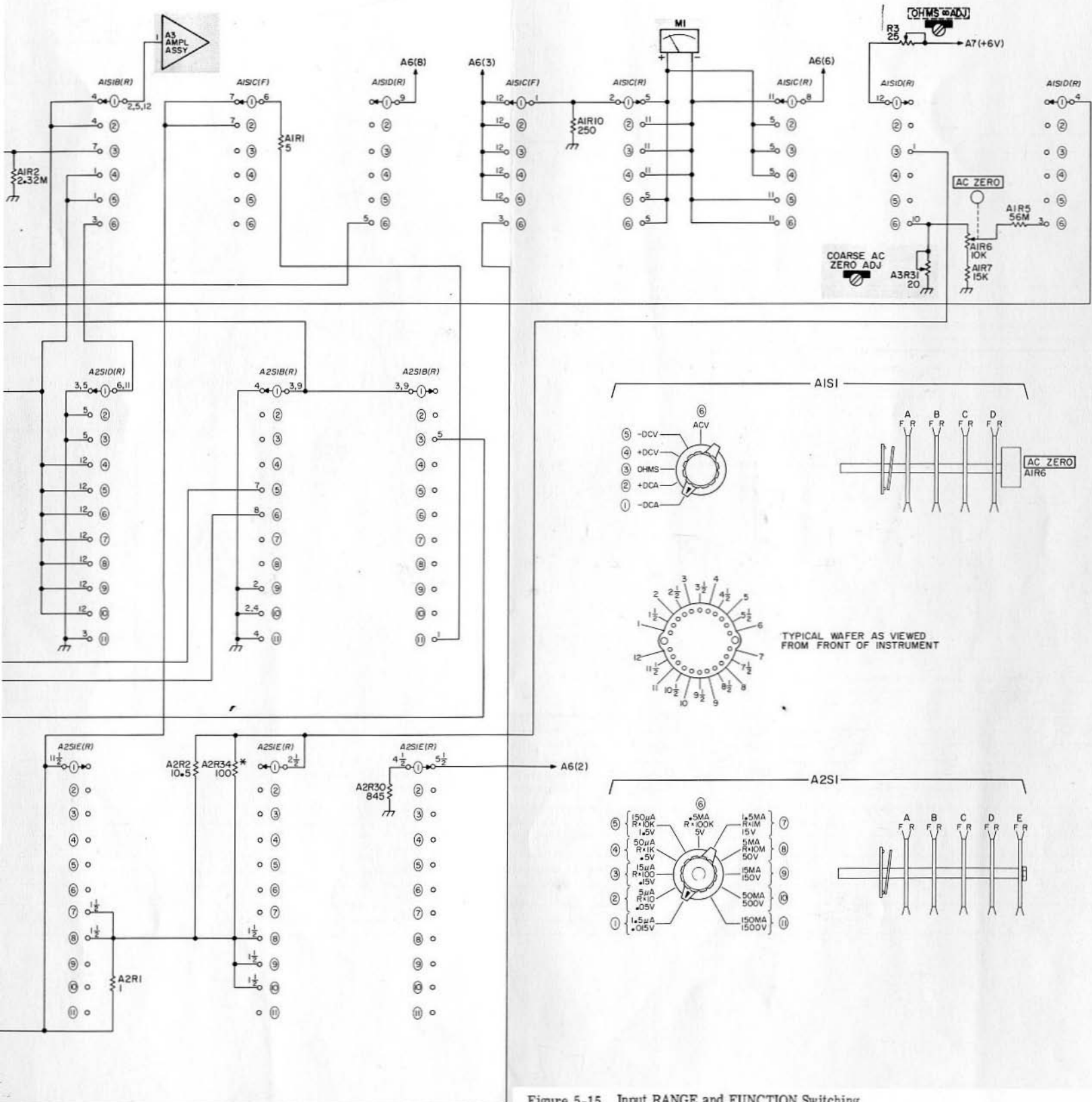

Figure 5-15. Input RANGE and FUNCTION Switching Schematic

## SECTION VI

### REPLACEABLE PARTS

#### 6-1. INTRODUCTION.

6-2. This section contains information for ordering replacement parts. Table 6-1 lists parts in alpha-numerical order of their reference designators and indicates the description and  $\text{\textcircled{S}}$  stock number of each part, together with any applicable notes. Table 6-2 lists parts in alpha-numerical order of their  $\text{\textcircled{S}}$  stock number and provides the following information on each part:

- a. Description of the part (see list of abbreviations below).
- b. Typical manufacturer of the part in a five-digit code (see list of manufacturers in Appendix).
- c. Manufacturer's part number.
- d. Total quantity used in the instrument (TQ column).

6-3. Replaceable hardware parts, not listed in Table 6-1 or 6-2, are listed in Table 6-3 in alphabetical order of description.

#### 6-4. ORDERING INFORMATION.

6-5. To obtain replacement parts, address order or inquiry to your local Hewlett-Packard Field Office (see lists at rear of this manual for addresses). Identify parts by their Hewlett-Packard stock numbers.

#### 6-6. NON-LISTED PARTS.

6-7. To obtain a part that is not listed, include:

- a. Instrument model number.
- b. Instrument serial number.
- c. Description of the part.
- d. Function and location of the part.

#### REFERENCE DESIGNATORS

A = assembly	F = fuse	P = plug	V = vacuum tube, neon bulb, photocell, etc.
B = motor	FL = filter	Q = transistor	W = cable
C = capacitor	J = jack	R = resistor	X = socket
CR = diode	K = relay	RT = thermistor	XF = fuseholder
DL = delay line	L = inductor	S = switch	XDS = lampholder
DS = device signaling (lamp)	M = meter	T = transformer	Z = network
E = misc electronic part	MP = mechanical part		

#### ABBREVIATIONS

a = amperes	elect = electrolytic	mtg = mounting	rot = rotary
bp = bandpass	encap = encapsulated	my = mylar	rms = root-mean-square
bwo = backward wave oscillator	f = farads	NC = normally closed	rmo = rack mount only
c = carbon	fxd = fixed	Ne = neon	s-b = slow-blow
cer = ceramic	Ge = germanium	NO = normally open	Se = selenium
cmo = cabinet mount only	grd = ground (ed)	NPO = negative positive zero (zero temperature coefficient)	sect = section(s)
coef = coefficient	h = henries	nsr = not separately replaceable	Si = silicon
com = common	Hg = mercury	obd = order by description	sil = silver
comp = composition	imp = impregnated	p = peak	sl = slide
conn = connection	incd = incandescent	pc = printed circuit board	td = time delay
crt = cathode-ray tube	ins = insulation (ed)	pf = picofarads = $10^{-12}$ farads	TiO <sub>2</sub> = titanium dioxide
dep = deposited	K = kilo = 1000	pp = peak to peak	tog = toggle
EIA = Tubes or transistors meeting Electronic Industries' Association standards will normally result in instrument operating within specifications; tubes and transistors selected for best performance will be supplied if ordered by $\text{\textcircled{S}}$ stock numbers.	lin = linear taper	piv = peak inverse voltage	tol = tolerance
	log = logarithmic taper	pos = position (s)	trim = trimmer
	m = milli = $10^{-3}$	pot = potentiometer	tw = traveling wave tube
	M = megohms	rect = rectifier	var = variable
	ma = milliamperes		w/ = with
	$\mu$ = micro = $10^{-6}$		W = watts
	minat = miniature		ww = wirewound
	mfgl = metal film on glass		w/o = without
	mfr = manufacturer		* = optimum value selected at factory, average value shown (part may be omitted)

Table 6-1. Replaceable Parts

REFERENCE DESIGNATOR	-hp- PART NO.	TQ	DESCRIPTION	MFR.	MFR. PART NO.
A1	410C-19B		Switch Assembly: Selector	-hp-	
R1	0727-0004	1	R: fxd C flm $5 \Omega \pm 1\%$ 1/2 W	94459	CVS
R2	0727-0480	1	R: fxd C flm $2.32 M\Omega \pm 1\%$ 0.5 W	94459	CVF
R3, R4			Not assigned		
R5	0687-5661	2	R: fxd comp $56 M\Omega \pm 10\%$ 1/2 W	01121	EB5661
R6	2100-0389	1	R: var ww lin $10 k\Omega \pm 10\%$ 5 W	-hp-	
R7	0687-1531	1	R: fxd comp $15 k\Omega \pm 10\%$ 1/2 W	01121	EB1531
R8, R9			Not assigned		
R10	0727-0479	1	R: fxd C flm $250 \Omega \pm 1\%$ 1/2 W	94459	CVF
S1	3100-0383	1	Switch: rotary 4-section 6-position (FUNCTION)	76854	obd
A2	410C-19A		Switch Assembly: Range	-hp-	
R1	0728-0004	2	R: fxd C flm $1 \Omega \pm 1\%$ 1/2 W	94459	CVF
R2	0727-0955	1	R: fxd C flm $10.5 \Omega \pm 1\%$ 1/2 W	94459	CVF
R3	0728-0004		R: fxd C flm $1 \Omega \pm 1\%$ 1/2 W	94459	CVF
R4	0733-0018	1	R: fxd C flm $89 M\Omega \pm 1\%$ 2 W	03888	HV2000
R5	<del>0727-0455</del>		Not assigned		
R6	0687-1031	1	R: fxd comp $10 k\Omega \pm 10\%$ 1/2 W	01121	EB1031
R7	0727-0478	1	R: fxd C flm $2.21 M\Omega \pm 1\%$ 1/2 W	94459	CVF
R8, R9			Not assigned		
R10	0730-0176	1	R: fxd $6 M\Omega \pm 0.5\%$ 1 W	94459	CVC
R11	0727-0459	1	R: fxd C flm $2 M\Omega \pm 0.5\%$ 1 W	01295	CDIR
R12	0727-0458	1	R: fxd C flm $700 k\Omega \pm 0.5\%$ 1/2 W	94459	CVF
R13	0727-0457	1	R: fxd C flm $200 k\Omega \pm 1\%$ 1/2 W	94459	CVF
R14	0727-0456	1	R: fxd C flm $70 k\Omega \pm 0.5\%$ 1/2 W	94459	CVF
R15	0727-0455	1	R: fxd C flm $20 k\Omega \pm 0.5\%$ 1/2 W	94459	CVF
R16	0727-0451	1	R: fxd C flm $1000 \Omega \pm 0.5\%$ 1/2 W	94459	CVF
R17	0727-0454	1	R: fxd C flm $6000 \Omega \pm 0.5\%$ 1/2 W	94459	CVF
R18	0727-0453	1	R: fxd C flm $2000 \Omega \pm 0.5\%$ 1/2 W	94459	CVF
R19	0727-0452	1	R: fxd C flm $700 \Omega \pm 0.5\%$ 1/2 W	94459	CVF
R20	0727-0450	1	R: fxd C flm $200 \Omega \pm 0.5\%$ 1/2 W	94459	CVF
R21	0727-0449	1	R: fxd C flm $70 \Omega \pm 1\%$ 1/2 W	94459	CVF
R22	0727-0448	2	R: fxd C flm $20 \Omega \pm 1\%$ 1/2 W	94459	CVF
R23	0727-0446	1	R: fxd C flm $7 \Omega \pm 1\%$ 1/2 W	94459	CVS
R24	0727-0445	1	R: fxd C flm $2 \Omega \pm 1\%$ 1/2 W	94459	CVS
R25	410C-26B	1	R: fxd $0.7 \Omega$	-hp-	
R26	410C-26A	1	R: fxd $0.3 \Omega$	-hp-	
R27 thru R29			Not assigned		
R30	0727-0701	1	R: fxd C flm $845 \Omega \pm 1\%$ 1/2 W	94459	CVF
R31	0727-0031	1	R: fxd C flm $60 \Omega \pm 1\%$ 1/2 W	01295	DC1/2PR
R32	0727-0448		R: fxd C flm $20 \Omega \pm 1\%$ 1/2 W	94459	CVF
R33	0727-0948	1	R: fxd C flm $10 \Omega \pm 1\%$ 1/2 W	94459	CVF
R34*	0687-1011	1	R: fxd comp $100 \Omega \pm 10\%$ 1/2 W	01121	EB1011
S1	3100-0382	1	Switch: rotary 5-section 11-position (RANGE)		
A3	410C-65A		Assembly: Amplifier	-hp-	
A1	1990-0020		Assembly: Chopper Block	-hp-	
V1 thru V4			Not separately replaceable, part of Chopper Assembly (1990-0020)		

Table 6-1. Replaceable Parts (Cont'd)

REFERENCE DESIGNATOR	-hp- PART NO.	TQ	DESCRIPTION	MFR.	MFR. PART NO.
A3 (Cont'd)					
A2	1990-0207		Assembly: Lamp	-hp-	
C1			Not separately replaceable, part of Lamp Assembly (1990-0207)		
DS1, DS2			Not separately replaceable, part of Lamp Assembly (1990-0207)		
R1, R2			Not separately replaceable, part of Lamp Assembly (1990-0207)		
C1	0160-2641	1	C: fxd poly 0.1 $\mu$ F $\pm 10\%$ 50 vdcw	56289	P136072
C2	0160-3116	1	C: fxd poly 0.047 $\mu$ F $\pm 10\%$ 50 vdcw	56289	P136049
C3			Not assigned		
C4	0160-0161	1	C: fxd my 0.01 $\mu$ F 200 vdcw	56289	192P10392
C5	0140-0208	1	C: fxd mica 680 pF $\pm 5\%$ 300 vdcw	00853	obd
C6	0160-2128	1	C: fxd my 0.33 $\mu$ F $\pm 20\%$ 200 vdcw	72354	F307C334M
C7			Not assigned		
C8	0180-0039	1	C: fxd Al elect 100 $\mu$ F 12 vdcw	56289	D32697
C9	0160-3366	2	C: fxd my 0.22 $\mu$ F $\pm 20\%$ 200 vdcw	72354	F307C224M
C10			Not assigned		
C11	0180-1819	1	C: fxd Al elect 100 $\mu$ F 50 vdcw	56289	30D107G0500H2
C12	0160-3366		C: fxd my 0.22 $\mu$ F $\pm 20\%$ 200 vdcw	72354	F307C224M
C13	0150-0096	1	C: fxd cer 0.05 $\mu$ F 100 vdcw	72982	845-X5V-5032
C14	0170-0018	1	C: fxd my 1 $\mu$ F $\pm 5\%$ 200 vdcw	84411	HEW-4
C15			Not assigned		
C16	0140-0154	1	C: fxd mica 1300 pF $\pm 5\%$ 500 vdcw	14655	RCM15E101K
CR1, CR2	1901-0156	1	Diode: Si 50 mA	03877	SG3288
Q1	1850-0013	1	TSTR: Ge PNP	86684	CP2366
Q2	1850-0040	1	TSTR: Ge PNP	04713	SA591
R1	0687-6841	1	R: fxd comp 680 k $\Omega$ $\pm 10\%$ 1/2 W	01121	EB6841
R2	0687-1851		R: fxd comp 1.8 M $\Omega$ $\pm 10\%$ 1/2 W	01121	EB1851
R3	0811-0998	1	R: fxd comp 100 $\Omega$ $\pm 1\%$ 1/4 W	-hp-	
R4			Not assigned		
R5	2100-0412 <b>760</b>	1	R: var comp lin <del>76</del> <sup>50k</sup> k $\Omega$ $\pm 30\%$ 1/4 W	71590	Series 5 Type 70-1
R6			Not assigned		
R7	0687-5661		R: fxd comp 56 M $\Omega$ $\pm 10\%$ 1/2 W	01121	EB5661
R8	0687-4731	1	R: fxd comp 47 k $\Omega$ $\pm 10\%$ 1/2 W	01121	EB4731
R9	0687-4701	1	R: fxd comp 47 $\Omega$ $\pm 10\%$ 1/2 W	01121	EB4701
R10, R11			Not assigned		
R12	0757-0164	1	R: fxd met flm 5600 $\Omega$ $\pm 2\%$ 1/2 W	07115	C20
R13	0757-0166	2	R: fxd met flm 30 k $\Omega$ $\pm 2\%$ 1/2 W	07115	C20
R14	0757-0163	1	R: fxd met flm 3000 $\Omega$ $\pm 2\%$ 1/2 W	07115	C20
R15	0757-0165	1	R: fxd met flm 13 k $\Omega$ $\pm 2\%$ 1/2 W	07115	C20
R16, R17			Not assigned		
R18	0757-0091	1	R: fxd met flm 18 k $\Omega$ $\pm 2\%$ 1/2 W	07115	C20
R19	0757-0166		R: fxd met flm 30 k $\Omega$ $\pm 2\%$ 1/2 W	07115	C20
R20	0687-1021	3	R: fxd comp 1000 $\Omega$ $\pm 10\%$ 1/2 W	01121	EB1021
R21	2100-0396	1	R: var ww lin 10 k $\Omega$ $\pm 20\%$ 1 W	79727	EB70PAB
R22, R23			Not assigned		
R24	0687-2751	1	R: fxd 2.7 M $\Omega$ $\pm 10\%$ 1/2 W	01121	EB2751
R25	0687-2221	1	R: fxd comp 2.2 k $\Omega$ $\pm 10\%$ 1/2 W	01121	EB2221
R26	0687-1021		R: fxd comp 1000 $\Omega$ $\pm 10\%$ 1/2 W	01121	EB1021
R27 thru R29			Not assigned		
R30	2100-0413	1	R: var comp lin 2.5 M $\Omega$ $\pm 20\%$ 1/4 W	71590	Series 5 Type 70-1

Table 6-1. Replaceable Parts (Cont'd)

REFERENCE DESIGNATOR	-hp- PART NO.	TQ	DESCRIPTION	MFR.	MFR. PART NO.
A3 (Cont'd)					
R31	2100-0227	1	R: var ww lin 20 $\Omega \pm 10\%$ 1 W	-hp-	
V1	1932-00 <sup>45</sup>	1	Tube: electron 12AT7 dual triode	80131	12AT7
A4, A5			Not assigned		
A6					
	410C-65B		Assembly: Calibration	-hp-	
CR1	1901-0025	1	Diode: Si 50 mA	93332	D3C72
R1	0727-0751	1	R: fxd C flm 1000 $\Omega \pm 1\%$ 1/2 W	94459	CVF
R2			Not assigned		
R3	2100-0394	6	R: var ww lin 300 $\Omega \pm 20\%$ 1 W	11236	Series 110
R4	0727-0747	2	R: fxd C flm 750 $\Omega \pm 1\%$ 1/2 W	94459	CVF
R5	2100-0394		R: var ww lin 300 $\Omega \pm 20\%$ 1 W	11236	Series 110
R6	0728-0011	1	R: fxd C flm 360 $\Omega \pm 1\%$ 1/2 W	94459	CVF
R7	2100-0394		R: var ww lin 300 $\Omega \pm 20\%$ 1 W	11236	Series 110
R8	0728-0010	1	R: fxd C flm 220 $\Omega \pm 1\%$ 1/2 W	94459	CVS
R9 thru R13			Not assigned		
R14	2100-0394		R: var ww lin 300 $\Omega \pm 20\%$ 1 W	11236	Series 110
R15			Not assigned		
R16	0758-0048	1	R: fxd met flm 8200 $\Omega \pm 5\%$ 1/2 W	07115	C20
R17	0727-0866	1	R: fxd C flm 180 $\Omega \pm 1\%$ 1/2 W	94459	CVF
R18	2100-0394		R: var ww lin 300 $\Omega \pm 20\%$ 1 W	11236	Series 110
R19			Not assigned		
R20	2100-0395	1	R: var comp lin 300 $\Omega \pm 20\%$ 1/4 W	71590	Series 5 Type 70-1
R21	0727-0475	1	R: fxd C 970 $\Omega \pm 0.5\%$ 1/2 W	94459	CD1/2MR
A7					
	410C-65C		Assembly: Power Supply	-hp-	
C1*	0140-0041	1	C: fxd mica 100 pF $\pm 5\%$ 500 vdcw	04062	RCM15E101J
CR1 thru CR5			Not assigned		
CR6	1902-0026	1	Diode: breakdown 36.5 V $\pm 10\%$ 0.4 W	04713	SZ10939-343
CR7	1902-0567	1	Diode: breakdown 9.09 V $\pm 10\%$ 500 mW	59875	PS18256A
CR8	1902-0049	1	Diode: breakdown 6.19 V $\pm 5\%$ 0.4 W	04713	SZ10939-122
R1, R2	0764-0003	2	R: fxd met flm 3300 $\Omega \pm 5\%$ 2 W	07115	C42S
R3	0758-0018	1	R: fxd met flm 15 k $\Omega \pm 5\%$ 1/2 W	07115	C20
R4	0764-0026	1	R: fxd met flm 13 k $\Omega \pm 5\%$ 2 W	07115	C42S
R5, R6			Not assigned		
<del>R7</del>	<del>0758-0018</del>	1	<del>R: fxd met flm 1100 <math>\Omega \pm 5\%</math> 1/2 W</del>	07115	C20
R8	0758-00 <sup>502</sup>	1	R: fxd met flm 1200 $\Omega \pm 5\%$ 1/2 W <sup>560r</sup>	07115	C20
R9			Not assigned		
R10	0758-0083	1	R: fxd met flm 68 $\Omega \pm 5\%$ 1/2 W	07115	C20
A8					
	11036A		Assembly: AC Probe (-hp- Model 11036A, complete)	-hp-	
C1			Not separately replaceable, part of AC Probe (11036A)		
C2			Not separately replaceable, part of AC Probe (11036A)		
P1	1251-0209	1	Plug: telephone 3 conductor	82389	2P-1297

Table 6-1. Replaceable Parts (Cont'd)

REFERENCE DESIGNATOR	-hp- PART NO.	TQ	DESCRIPTION	MFR.	MFR. PART NO.
A8 (Cont'd)					
R1			Not separately replaceable, part of AC Probe (11036A)		
V1	00410-87901		Tube: electron diode	-hp-	
C1	0170-0021	1	C: fxd my 4700 pF $\pm 10\%$ 400 vdcw	84411	620SJ0047
C2	0170-0022	1	C: fxd my 0.1 $\mu$ F $\pm 10\%$ 600 vdcw	59875	HEW-17
C3	0150-0023	1	C: fxd cer 2000 pF $\pm 20\%$ 1000 vdcw	56289	19C203A
C4			Not assigned		
C5	0180-0025	1	C: fxd Al elect 4x 20 $\mu$ F +50% -10% 450 vdcw	00853	Type PLI
C6	0180-0153	1	C: fxd Al elect 2x 1200 $\mu$ F +100% -10% 20 vdcw	00853	4S4039
CR1, CR2	1901-0036	1	Diode: Si 300 mA	01841	obd
CR3, CR4	1901-0049	1	Diode: Si 500 mA	86684	34934
DS1	<del>1450-0106</del> 2140-0244	1	Light indicator: Al <sup>H</sup> neon (p/o S3)	87034	A1C
F1	2110-0018	1	Fuse: cartridge slow-blow 0.25 A 125 V	71400	MDL1/4
J1	1251-0200	1	Jack: telephone 3 conductor	82389	3J-1291
J2			Assembly: DC AMPLIFIER OUTPUT (see MISCELLANEOUS for Part Nos.		
J3	1251-0148	1	Connector: power cord receptacle	82389	AC3G
M1	1120-0317	1	Meter: 0 - 1 mA	-hp-	
Q1	1850-0098	1	TSTR: Ge PNP	83298	B-1493
R1	0727-0274	1	R: fxd C flm 1 M $\Omega$ $\pm 1\%$ 1/2 W	94459	CVF
R2	0758-0086	1	R: fxd met flm 100 $\Omega$ $\pm 5\%$ 1/4 W	07115	C07
R3	2100-0415	1	R: var ww lin 25 $\Omega$ $\pm 10\%$ 2 W	08984	FFF-1
R4			Not assigned		
R5	0687- <del>6831</del> 3331	1	R: fxd comp <del>86</del> k $\Omega$ $\pm 10\%$ 1/2 W 33K	01121	EB6831
R6	0727-0231	1	R: fxd C flm 284 k $\Omega$ $\pm 0.5\%$ 1/2 W	91637	DCS1/2
R7	0727-0168	1	R: fxd C flm 15 k $\Omega$ $\pm 1\%$ 1/2 W	91637	DCS1/2-15
R8	2100-1567	1	R: var ww 10 k $\Omega$ $\pm 10\%$ 2 W	11236	117
R9	0727-0180	1	R: fxd C flm 25.5 k $\Omega$ $\pm 1\%$ 1/2 W	91637	DCS1/2-15
S1	3101-0100	1	Switch: SPST pushbutton	87034	SW-624-109
S2	3101-0033	1	Switch: DPDT slide	79727	G-326 6510
T1	9100-0174	1	Transformer: power	-hp-	
W1	8120-0078	1	Cable: power 3 conductor 7-1/2 ft. long w/NEMA plug	70903	KH-4147
XQ1	1200-0044	1	Socket: transistor TO-3	97913	M7(PB)
			<u>MISCELLANEOUS</u>		
	1220-0066	1	Shield: tube	82252	319A-2
	1490-0088	1	Clip: ground	71785	422-11-11-095
	1510-0006	1	Binding post: black (p/o J2)	-hp-	
	1510-0007	2	Binding post: red (p/o J2)	-hp-	
	1490-0013		NEEDLE FOR D.C. PROBE		
NEW TOPC.	5060-0712				
	410-C 95A		NEW ZERO ADJ. KIT		

410C-21D COMMON TEST LOAD

Table 6-2. Replaceable Hardware

REFERENCE DESIGNATOR	-hp- PART NO.	TQ	DESCRIPTION	MFR.	MFR. PART NO.
	11036-42102	1	Boot: AC plug (p/o 11036A)	-hp-	
	11036-42101	1	Boot: AC probe (p/o 11036A)	-hp-	
	412A-83A	3	Boot: cable	-hp-	
	410C-12A	1	Bracket: connector (used with A3 connector)	-hp-	
	410C-12B	1	Bracket: switch (used with A6 connector)	-hp-	
	00410-01202	2	Bracket: cover retainer	-hp-	
	1200-0081	2	Bushing: insulator (used with Q1)	26365	974 Special
	1410-0091	2	Bushing: panel (used with A1S1 and A2S2)	28520	SB-437-4
	0400-0019	3	Bushing: strain relief	-hp-	
	410C-1A	1	Chassis: transformer	-hp-	
	410B-21H	1	Clip: grounding (p/o 11036A)	-hp-	
	1251-0195	1	Connector: 10 pin P.C.	02660	143-010-09 (109)
	1251-0213	1	Connector: 15 pin P.C.	95354	SD-615W (125)
	410B-21P	1	Contact: Diode (p/o 11036A)	-hp-	
	3130-0038	1	Coupler: switch	45255	10X20X1
	5000-0703	1	Cover: side	-hp-	
	00410-64102	1	Cover: top (requires 2 brackets 00410-01202)	-hp-	
	5060-0714	1	Cover: bottom	-hp-	
	5060-0727	2	Foot assembly	-hp-	
	5060-0703	2	Frame: side	-hp-	
	410B-21J	1	Ground lead assembly (p/o 11036A)	-hp-	
	5040-0700	2	Hinge (used with tilt stand)	-hp-	
	1400-0084	1	Holder: fuse	75915	342014
	0340-0086	1	Insulator: binding post double	-hp-	
	0340-0091	1	Insulator: binding post triple	-hp-	
	1520-0001	2	Insulator: capacitor (used with C1 - C2)	56137	XP
	0340-0007	1	Insulator: ceramic standoff	71590	obd
	0370-0112	1	Knob: black bar concentric	-hp-	
	0370-0113	1	Knob: black bar w/arrow	-hp-	
	0370-0114	1	Knob: red w/arrow	-hp-	
	0360-0016	1	Lug: solder lock #4	78452	718
	0360-0007	4	Lug: solder #10	78189	2501-10-00
	0360-0042	2	Lug: solder 90°	79963	obd
	2260-0001	4	Nut: hex 4-40 x 1/4 in.	-hp-	
	2420-0001	4	Nut: hex 6-32 x 5/16 in. w/lock	83385	obd
	2820-0001	3	Nut: hex 10-32 x 3/8 in.	73743	obd
	2950-0006	3	Nut: hex 1/4-32 x 3/8 in.	73734	9000
	2950-0001	3	Nut: hex 3/8-32 x 1/2 in.	73743	obd
	2950-0037	1	Nut: hex 1/2-16 x 11/16 in.	75915	obd
	2950-0038	1	Nut: hex 1/2-24 x 11/16 in.	75915	903-12
	0590-0039	4	Nut: speed 6-32	78553	C6800-632-1
	0590-0052	2	Nut: speed 6-32	78553	C8020-632-4
	410C-2A	1	Panel: front	-hp-	
	410C-2C	1	Panel: rear	-hp-	
	410C-41A	1	Plate: insulator (used with A1S1 and A2S2)	-hp-	
	1200-0043	1	Plate: insulator (used with Q1)	71785	294457
	1251-0209	1	Plug: telephone (p/o 11036A)	82389	2P-1297
	410B-21C	1	Probe: contact assembly	-hp-	
	410B-21D	1	Probe head	-hp-	
	410B-21F	1	Ring: retainer (p/o 11036A)	-hp-	
	2200-0006	2	Screw: machine 4-40 x 3/8 in. RH	80120	obd
	2200-0014	2	Screw: machine 4-40 x 9/16 in. RH	80120	obd
	2370-0001	20	Screw: machine 6-32 x 1/4 in. RH	80120	obd



Table 6-2. Replaceable Hardware (Cont'd)

REFERENCE DESIGNATOR	-hp- PART NO.	TQ	DESCRIPTION	MFR.	MFR. PART NO.
	2390-0007	4	Screw: machine 6-32 x 5/16 in. BH w/lock	83385	obd
	2370-0002	8	Screw: machine 6-32 x 3/8 in. FH	80120	obd
	2370-0003	2	Screw: machine 6-32 x 1/2 in. FH	80120	obd
	410B-21E	1	Sleeve (p/o 11036A)	-hp-	
	1460-0087	1	Spring: diode contact (p/o 11036A)	91260	obd
	1490-0031	1	Stand: tilt	91260	obd
	410C-66A	2	Support: circuit board (used with A3)	-hp-	
	410C-21D	1	Test lead assembly: COM	-hp-	
	410C-21C	1	Test lead assembly: DCA -OHMS	-hp-	
	410C-21A	1	Test lead assembly: DCV (includes R1)	-hp-	
	5020-0704	1	Trim: meter	-hp-	
	11036-62101	1	Tube: socket and cable assembly (p/o 11036A)	-hp-	
	3050-0066	2	Washer: flat #6	73734	obd
	3050-0067	3	Washer: flat 3/8 in. ID	73734	obd
	0900-0016	1	Washer: fuse holder	76680	622710
	2190-0005	2	Washer: lock #4 external	80120	obd
	2190-0004	2	Washer: lock #4 internal	78189	SF1904
	2190-0003	2	Washer: lock #4 split	83385	obd
	2190-0047	30	Washer: lock #6 countersunk	78189	obd
	2190-0011	2	Washer: lock #10 internal	78189	1910
	2190-0028	2	Washer: lock #10 int/ext	78189	4010-18-00
	2190-0027	3	Washer: lock 1/4 in. internal	78189	1914
	2190-0022	4	Washer: lock 3/8 in. ID	78189	1920
	2190-0037	2	Washer: lock 1/2 in. internal	78189	1224-08
	1400-0090	1	Washer: Neoprene	75915	901-2

Table 6-2. Replaceable Parts (Cont'd)

Ⓢ PART NO.	DESCRIPTION	MFR	MFR PART NO.	TQ
0687-1031	R: fxd, comp, 10 K ohms $\pm 10\%$ , 1/2 w	01121	EB1031	1
0687-1531	R: fxd, comp, 15 K ohms $\pm 10\%$ , 1/2 w	01121	EB1531	1
0687-1851	R: fxd, comp, 1.8 megohms $\pm 10\%$ , 1/2 w	01121	EB1851	1
0687-2221	R: fxd, comp, 2.2 K ohms $\pm 10\%$ , 1/2 w	01121	EB2221	1
0687-2751	R: fxd, 2.7 megohms $\pm 10\%$ , 1/2 w	01121	EB2751	1
0687-4701	R: fxd, comp, 47 ohms $\pm 10\%$ , 1/2 w	01121	EB4701	1
0687-4731	R: fxd, comp, 47 K ohms $\pm 10\%$ , 1/2 w	01121	EB4731	1
0687-5661	R: fxd, comp, 56 megohms $\pm 10\%$ , 1/2 w	01121	EB5661	2
0687-6831	R: fxd, comp, 68 K ohms $\pm 10\%$ , 1/2 w	01121	EB6831	1
0687-6841	R: fxd, comp, 680 K ohms $\pm 10\%$ , 1/2 w	01121	EB6841	1
0727-0004	R: fxd, deposit carbon flm, 5 ohms $\pm 1\%$ , 1/2 w	94459	CVS	1
0727-0031	R: fxd, carbon flm, 60 ohms $\pm 1\%$ , 1/2 w	01295	DC1/2PR	1
0727-0168	R: fxd, carbon flm, 15 K ohms $\pm 1\%$ , 1/2 w	91637	DCS1/2-15	1
0727-0180	R: fxd, carbon flm, 25.5 K ohms $\pm 1\%$ , 1/2 w	91637	DCS1/2-15	1
0727-0231	R: fxd, carbon flm, 284 K ohms $\pm 0.5\%$ , 1/2 w	91637	DCS1/2	1
0727-0274	R: fxd, carbon flm, 1 megohm $\pm 1\%$ , 1/2 w	94459	CVF	1
0727-0445	R: fxd, carbon flm, 2 ohms $\pm 1\%$ , 1/2 w	94459	CVS	1
0727-0446	R: fxd, carbon flm, 7 ohms $\pm 1\%$ , 1/2 w	94459	CVS	1
0727-0448	R: fxd, carbon flm, 20 ohms $\pm 1\%$ , 1/2 w	94459	CVF	2
0727-0449	R: fxd, carbon flm, 70 ohms $\pm 1\%$ , 1/2 w	94459	CVF	1
0727-0450	R: fxd, carbon flm, 200 ohms $\pm 0.5\%$ , 1/2 w	94459	CVF	1
0727-0451	R: fxd, carbon flm, 1 K ohms $\pm 0.5\%$ , 1/2 w	94459	CVF	1
0727-0452	R: fxd, carbon flm, 700 ohms $\pm 0.5\%$ , 1/2 w	94459	CVF	1
0727-0453	R: fxd, carbon flm, 2 K ohms $\pm 0.5\%$ , 1/2 w	94459	CVF	1
0727-0454	R: fxd, carbon flm, 6 K ohms $\pm 0.5\%$ , 1/2 w	94459	CVF	1
0727-0455	R: fxd, carbon flm, 20 K ohms $\pm 0.5\%$ , 1/2 w	94459	CVF	1
0727-0456	R: fxd, carbon flm, 70 K ohms $\pm 0.5\%$ , 1/2 w	94459	CVF	1
0727-0457	R: fxd, carbon flm, 200 K ohms $\pm 1\%$ , 1/2 w	94459	CVF	1
0727-0458	R: fxd, carbon flm, 700 K ohms $\pm 0.5\%$ , 1/2 w	94459	CVF	1
0727-0459	R: fxd, carbon flm, 2 megohms $\pm 0.5\%$ , 1 w	01295	CD1R	1
0727-0475	R: fxd, deposit carbon, 970 ohms $\pm 0.5\%$ , 1/2 w	94459	CD1/2MR	1
0727-0478	R: fxd, carbon flm, 2.21 megohms $\pm 1\%$ , 1/2 w	94459	CVF	1
0727-0479	R: fxd, carbon flm, 250 ohms $\pm 1\%$ , 1/2 w	94459	CVF	1
0727-0480	R: fxd, carbon flm, 2.32 megohms $\pm 1\%$ , 0.5 w	94459	CVF	1
0727-0701	R: fxd, carbon flm, 845 ohms $\pm 1\%$ , 1/2 w	94459	CVF	1
0727-0747	R: fxd, carbon flm, 750 ohms $\pm 1\%$ , 1/2 w	94459	CVF	2
0727-0751	R: fxd, carbon flm, 1 K ohm $\pm 1\%$ , 1/2 w	94459	CVF	1
0727-0866	R: fxd, carbon flm, 180 ohms $\pm 1\%$ , 1/2 w	94459	CVF	1
0727-0948	R: fxd, carbon flm, 10 ohms $\pm 1\%$ , 1/2 w	94459	CVF	1
0727-0955	R: fxd, carbon flm, 10.5 ohms $\pm 1\%$ , 1/2 w	94459	CVF	1
0728-0004	R: fxd, carbon flm, 1 ohm $\pm 1\%$ , 1/2 w	94459	CVF	2
0728-0010	R: fxd, carbon flm, 220 ohms $\pm 1\%$ , 1/2 w	94459	CVS	1
0728-0011	R: fxd, carbon flm, 360 ohms $\pm 1\%$ , 1/2 w	94459	CVF	1
0730-0176	R: fxd, 6 megohms $\pm 0.5\%$ , 1 w	94459	CVC	1
0733-0018	R: fxd, carbon flm, 89 megohms $\pm 1\%$ , 2 w	03888	HV2000	1
0757-0091	R: fxd, met flm, 18 K ohms $\pm 2\%$ , 1/2 w	07115	C20	1
0757-0163	R: fxd, met flm, 3 K ohms $\pm 2\%$ , 1/2 w	07115	C20	1
0757-0164	R: fxd, met flm, 5.6 K ohms $\pm 2\%$ , 1/2 w	07115	C20	1
0757-0165	R: fxd, met flm, 13 K ohms $\pm 2\%$ , 1/2 w	07115	C20	1
0757-0166	R: fxd, met flm, 30 K ohms $\pm 2\%$ , 1/2 w	07115	C20	2
0758-0018	R: fxd, met flm, 15 K ohms $\pm 5\%$ , 1/2 w	07115	C20	1
0758-0048	R: fxd, met flm, 8.2 K ohms $\pm 5\%$ , 1/2 w	07115	C20	1

# See introduction to this section

Table 6-2. Replaceable Parts (Cont'd)

PART NO.	DESCRIPTION	MFR	MFR PART NO.	TQ
0758-0069	R: fxd, met flm, 1.1 K ohm $\pm 5\%$ , 1/2 w	07115	C20	1
0758-0070	R: fxd, met flm, 1.2 K ohms $\pm 5\%$ , 1/2 w	07115	C20	1
0758-0083	R: fxd, met flm, 68 ohms $\pm 5\%$ , 1/2 w	07115	C20	1
0758-0086	R: fxd, met flm, 100 ohms $\pm 5\%$ , 1/4 w	07115	C07	1
0764-0003	R: fxd, met flm, 3.3 K ohms $\pm 5\%$ , 2 w	07115	C42S	1
0764-0026	R: fxd, met flm, 13 K ohms $\pm 5\%$ , 2 w	07115	C42S	1
0811-0998	R: fxd, comp, 100 ohms $\pm 1\%$ , 1/4 w	28480	0811-0998	1
1120-0317	Meter: 0 - 1 ma	28480	1120-0317	1
1200-0044	Socket, transistor: TO-3	97913	M7 (PB)	1
1251-0148	Connector, power cord receptacle	82389	AC3G	1
1251-0200	Jack: telephone, 3 conductor	82389	3J-1291	1
1251-0209	Plug: telephone, 3 conductor	82389	2P-1297	1
1450-0106	Light Indicator: A1C neon (p/o S3)	87034	A1C	1
1850-0013	Transistor: germanium, PNP	86684	CP2366	1
1850-0040	Transistor: germanium, PNP	04713	SA591	1
1850-0098	Transistor: germanium, PNP	83298	B-1493	1
1901-0025	Diode: si, 50 ma	93332	D3C72	1
1901-0036	Diode: si, 300 ma	01841	obd #	1
1901-0049	Diode: si, 500 ma	86684	34934	1
1901-0156	Diode: si, 50 ma	03877	SG3288	1
1902-0026	Diode: breakdown, junction, 36.5 v $\pm 10\%$ , 0.4 w	04713	SZ10939-343	1
1902-0049	Diode: breakdown, junction, 6.19 v $\pm 5\%$ , 0.4 w	04713	SZ10939-122	1
1902-0567	Diode: breakdown, junction, 9.09 v $\pm 10\%$ , 1.5 w	59875	PS18256A	1
1920-0010	Tube electron, EA53, diode	73445	EA53	1
1932-0027	Tube: electron, 12AT7, dual triode	000I1	2AT7	1
1990-0020	Ass'y - chopper block, includes:	28480	1990-0020	1
	C1                      R1, 2			
	DS1, 2                V1 thru 4			
1990-0207	Lamp ass'y	28480	1990-0207	1
2100-0227	R: var, ww, lin taper, 20 ohms $\pm 10\%$ , 1 w	28480	2100-0227	1
2100-0389	R: var, ww, lin taper, 10 K ohms $\pm 10\%$ , 5 w	28480	2100-0389	1
2100-0394	R: var, ww, lin taper, 300 ohms $\pm 20\%$ , 1 w	11236	Series 110	6
2100-0395	R: var, comp, lin taper, 300 ohms $\pm 20\%$ , 1/4 w	71590	Series 5, Type 70-1	1
2100-0396	R: var, ww, lin taper, 10 K ohms $\pm 20\%$ , 1 w	79727	E870PAB	1
2100-0413	R: var, comp, lin taper, 2.5 megohms $\pm 20\%$ , 1/4 w	71590	Series 5, Type 70-1	1
2100-0415	R: var, comp, lin taper, 25 ohms $\pm 10\%$ , 2 w	08984	FFF-1, Term. X, Y, Z	1
2100-0442	R: var, comp, lin taper, 40 K ohms $\pm 30\%$ , 1/4 w	71590	Series 5, Type 70-1	1
2100-1567	R: var, ww, 10 K ohms $\pm 10\%$ , 2 w	11236	117	1
2110-0018	Fuse: cartridge, slow-blow, 0.25 amp, 125 v	71400	MDL1/4	1
3100-0382	Switch: rotary, 5-section, 11-position	76854	obd #	1
3100-0383	Switch: rotary, 4-section, 6-position	76854	obd #	1
3101-0033	Switch: slide, DPDT	79727	G-326, 6510	1
3101-0100	Switch: SPST, pushbutton, w/pilot light		Rev. D	
3101-0100	Switch: SPST, pushbutton, w/pilot light	87034	SW-624-109	1
8120-0078	Cable, Power: 3 conductor, 7-1/2 ft. long, w/NEMA plug	70903	KH-4147	1
9100-0174	Transformer: power	28480	9100-0174	1

# See introduction to this section

Table 6-3. Replaceable Hardware

PART NO.	DESCRIPTION	MFR	MFR PART NO.	TQ
1510-0006	Binding post, black (p/o J2)	28480	1510-0006	1
1510-0007	Binding post, red (p/o J2)	28480	1510-0007	2
11036-42102	Boot, AC plug (p/o 11036A)	28480	11036-42102	1
11036-42101	Boot, AC probe (p/o 11036A)	28480	11036-42101	1
412A-83A	Boot, cable	28480	412A-83A	3
410C-12A	Bracket, connector (used with A3 connector)	28480	410C-12A	1
410C-12B	Bracket, switch (used with A6 connector)	28480	410C-12B	1
1200-0081	Bushing, insulator (used with Q1)	26365	974 Special	2
1410-0091	Bushing, panel (used with A1S1 and A2S2)	28520	SB-437-4	2
0400-0019	Bushing, strain relief	28480	0400-0019	3
410C-1A	Chassis, xfmr	28480	410C-1A	1
410B-21H	Clip, grounding (p/o 11036A)	28480	410B-21H	1
1251-0195	Connector, 10 pin P. C.	02660	143-010-09 (109)	1
1251-0213	Connector, 15 pin P. C.	000XX	SD-615W (125)	1
410B-21P	Contact, Diode (p/o 11036A)	28480	410B-21P	1
3130-0038	Coupler, switch	45255	10X20X1	1
5000-0703	Cover, side	28480	5000-0703	1
5060-0712	Cover, top	28480	5000-0712	2
5060-0714	Cover, bottom	28480	5060-0714	1
5060-0727	Foot Ass'y	28480	5060-0727	2
5060-0703	Frame, side	28480	5060-0703	2
410B-21J	Ground Lead Ass'y (p/o 11036A)	28480	410B-21J	1
5040-0700	Hinge (used with tilt stand)	28480	5040-0700	2
1400-0084	Holder, fuse	75915	342014	1
0340-0086	Insulator, binding post, double	28480	0340-0086	1
0340-0091	Insulator, binding post, triple	28480	0340-0091	1
1520-0001	Insulator, capacitor (used with C1 - C2)	56137	XP	2
0340-0007	Insulator, ceramic standoff	71590	obd#	1
0370-0112	Knob, black bar, concentric	28480	0370-0112	1
0370-0113	Knob, black bar, w/arrow	28480	0370-0113	1
0370-0114	Knob, red, w/arrow	28480	0370-0114	1
0360-0016	Lug, solder, lock, #4	78452	718	1
0360-0007	Lug, solder, #10	78189	2501-10-00	4
0360-0042	Lug, solder, 90°	79963	obd#	2
2260-0001	Nut, hex, 4-40 x 1/4 in.	28480	2260-0001	4
2420-0001	Nut, hex, 6-32 x 5/16 in., w/lock	83385	obd#	4
2820-0001	Nut, hex, 10-32 x 3/8 in.	73743	obd#	3
2950-0006	Nut, hex, 1/4-32 x 3/8 in.	73734	#9000	3
2950-0001	Nut, hex, 3/8-32 x 1/2 in.	73743	obd#	3
2950-0037	Nut, hex, 1/2-16 x 11/16 in.	75915	obd#	1
2950-0038	Nut, hex, 1/2-24 x 11/16 in.	75915	903-12	1
0590-0039	Nut, speed, 6-32	78553	C6800-632-1	4
0590-0052	Nut, speed, 6-32	78553	C8020-632-4	2
410C-2A	Panel, front	28480	410C-2A	1
410C-2C	Panel, rear	28480	410C-2C	1
410C-41A	Plate, insulator (used with A1S1 and A2S2)	28480	410C-41A	1

# See introduction to this section

Table 6-3. Replaceable Hardware (Cont'd)

PART NO.	DESCRIPTION	MFR	MFR PART NO.	TQ
1200-0043	Plate, insulator (used with Q1)	71785	294457	1
1251-0209	Plug, telephone (p/o 11036A)	82389	2P-1297	1
410B-21C	Probe contact ass'y	28480	410B-21C	1
410B-21D	Probe head	28480	410B-21D	1
410B-21F	Ring, retainer (p/o 11036A)	28480	410B-21F	1
	<u>MISCELLANEOUS</u>			
1490-0088	Clip: ground	71785	422-11-11-095	1
2200-0006	Screw, machine, 4-40 x 3/8 in. RH	80120	obd#	2
2200-0014	Screw, machine, 4-40 x 9/16 in. RH	80120	obd#	2
2370-0001	Screw, machine, 6-32 x 1/4 in. FH	80120	obd#	20
2390-0007	Screw, machine, 6-32 x 5/16 in. BH, w/lock	83385	obd#	4
2370-0002	Screw, machine, 6-32 x 3/8 in. FH	80120	obd#	8
2370-0003	Screw, machine, 6-32 x 1/2 in. FH	80120	obd#	2
1220-0066	Shield: tube	82252	319A-2	1
410B-21E	Sleeve (p/o 11036A)	28480	410B-21E	1
1460-0087	Spring, diode contact (p/o 11036A)	91260	obd#	1
1490-0031	Stand, tilt	91260	obd#	1
410C-66A	Support, circuit board (used with A3)	28480	410C-66A	2
410C-21D	Test lead ass'y, COM	28480	410C-21D	1
410C-21C	Test lead ass'y, DCA-OHMS	28480	410C-21C	1
410C-21A	Test lead ass'y, DCV (includes R1)	28480	410C-21A	1
5020-0704	Trim, meter	28480	5020-0704	1
11036-62101	Tube, socket and cable ass'y (p/o 11036A)	28480	11036-62101	1
3050-0066	Washer, flat, #6	73734	obd#	2
3050-0067	Washer, flat, 3/8 in. ID	73734	obd#	3
0900-0016	Washer, fuse holder	76680	622710	1
2190-0005	Washer, lock, #4 external	80120	obd#	2
2190-0004	Washer, lock, #4 internal	78189	SF1904	2
2190-0003	Washer, lock, #4 split	83385	obd#	2
2190-0047	Washer, lock, #6 countersunk	78189	obd#	30
2190-0011	Washer, lock, #10 internal	78189	1910	2
2190-0028	Washer, lock, #10 int/ext	78189	4010-18-00	2
2190-0027	Washer, lock, 1/4 in. internal	78189	1914	3
2190-0022	Washer, lock, 3/8 in. ID	78189	1920	4
2190-0037	Washer, lock, 1/2 in. internal	78189	1224-08	2
1400-0090	Washer, Neoprene	75915	901-2	1

# See introduction to this section

## CODE LIST OF MANUFACTURERS

The following code numbers are from the Federal Supply Code for Manufacturers Cataloging Handbooks H4-1 (Name to Code) and H4-2 (Code to Name) and their latest supplements. The date of revision and the date of the supplements used appear at the bottom of each page. Alphabetical codes have been arbitrarily assigned to suppliers not appearing in the H4 Handbooks.

Code No.	Manufacturer	Address	Code No.	Manufacturer	Address	Code No.	Manufacturer	Address
00000	U. S. A. Common	Any supplier of U. S.	05347	Ultronix, Inc.	San Mateo, Calif.	10411	Ti-Tal, Inc.	Berkeley, Calif.
00136	McCoy Electronics	Mount Holly Springs, Pa.	05397	Union Carbide Corp., Linde Div.,	Kemet Dept. Cleveland, Ohio	10646	Carborundum Co.	Niagara Falls, N. Y.
00213	Sage Electronics Corp.	Rochester, N. Y.	05574	Viking Ind. Inc.	Canoga Park, Calif.	11236	CTS of Berne, Inc.	Berne, Ind.
00287	Cemco Inc.	Danielson, Conn.	05574	Viking Ind. Inc.	Canoga Park, Calif.	11237	Chicago Telephone of California, Inc.	So. Pasadena, Calif.
00334	Humidial	Colton, Calif.	05593	Illumitron Engineering Co.	Sunnyvale, Calif.	11242	Bay State Electronics Corp.	Waltham, Mass.
00348	Microtron Co., Inc.	Valley Stream, N. Y.	05616	Cosmo Plastic (c/o Electrical Spec. Co.)	Cleveland, Ohio	11312	Teledyne Inc., Microwave Div.	Palo Alto, Calif.
00373	Garlock Inc.	Cherry Hill, N. J.	05624	Barber Colman Co.	Rockford, Ill.	11314	National Seal	Dowsey, Calif.
00656	Aerovox Corp.	New Bedford, Mass.	05728	Tiffen Optical Co.	Reslye Heights, Long Island, N. Y.	11534	Duncan Electronics Inc.	Costa Mesa, Calif.
00779	Amp. Inc.	Harrisburg, Pa.	05729	Metro-Tel Corp.	Westbury, N. Y.	11711	General Instrument Corp., Semiconductor Div., Products Group	Newark, N. J.
00781	Aircraft Radio Corp.	Boonton, N. J.	05783	Stewart Engineering Co.	Santa Cruz, Calif.	11717	Imperial Electronic, Inc.	Buena Park, Calif.
00815	Northern Engineering Laboratories, Inc.	Burlington, Wis.	05820	Wakefield Engineering Inc.	Wakefield, Mass.	11870	Melabs, Inc.	Palo Alto, Calif.
00853	Sangamo Electric Co., Pickens Div.	Pickens, S. C.	06004	Bassick Co., Div. of Stewart Warner Corp.	Bridgeport, Conn.	12136	Philadelphia Handle Co.	Camden, N. J.
00866	Goe Engineering Co.	City of Industry, Cal.	06090	Raychem Corp.	Redwood City, Calif.	12361	Grove Mfg. Co., Inc.	Shady Grove, Pa.
00891	Carl E. Holmes Corp.	Los Angeles, Calif.	06175	Bausch and Lomb Optical Co.	Rochester, N. Y.	12574	Gulton Ind. Inc. Data System Div.	Albuquerque, N. M.
00929	Microtab Inc.	Livingston, N. J.	06402	E. T. A. Products Co. of America	Chicago, Ill.	12697	Clarostat Mfg. Co.	Dover, N. H.
01002	General Electric Co., Capacitor Dept.	Hudson Falls, N. Y.	06540	Amalcom Electronic Hardware Co., Inc.	New Rochelle, N. Y.	12728	Elmar Filter Corp.	W. Haven, Conn.
01009	Alden Products Co.	Brockton, Mass.	06555	Beede Electrical Instrument Co., Inc.	Penacook, N. H.	12859	Nippon Electric Co., Ltd.	Tokyo, Japan
01121	Allen Bradley Co.	Milwaukee, Wis.	06666	General Devices Co., Inc.	Indianapolis, Ind.	12881	Meltek Electronics Corp.	Clark, N. J.
01255	Litton Industries, Inc.	Beverly Hills, Calif.	06751	Semcor Div. Components Inc.	Phoenix, Ariz.	12930	Delta Semiconductor Inc.	Newport Beach, Calif.
01281	TRW Semiconductors, Inc.	Lawndale, Calif.	06812	Torrington Mfg. Co., West Div.	Van Nuys, Calif.	12954	Dickson Electronics Corp.	Scottsdale, Arizona
01295	Texas Instruments, Inc., Transistor Products Div.	Dallas, Texas	06980	Varian Assoc. Eimac Div.	San Carlos, Calif.	13103	Thermolyt	Dallas, Texas
01349	The Alliance Mfg. Co.	Van Nuys, Calif.	07088	Bausch and Lomb Optical Co.	Rochester, N. Y.	13396	Telefunken (GmbH)	Hanover, Germany
01589	Pacific Relays, Inc.	Van Nuys, Calif.	07126	Digitalon Co.	Pasadena, Calif.	13835	Midland-Wright Div. of Pacific Industries, Inc.	Kansas City, Kansas
01930	Amerock Corp.	Rockford, Ill.	07137	Transistor Electronics Corp.	Minneapolis, Minn.	14099	Sem-Tech	Newbury Park, Calif.
01961	Pulse Engineering Co.	Santa Clara, Calif.	07138	Westinghouse Electric Corp. Electronic Tube Div.	Elmira, N. Y.	14193	Calif. Resistor Corp.	Santa Monica, Calif.
02114	Ferroxcube Corp. of America	Saugerties, N. Y.	07145	Filmohm Corp.	New York, N. Y.	14298	American Components, Inc.	Coshohocken, Pa.
02116	Wheeleck Signals, Inc.	Long Branch, N. J.	07223	Cinch-Graphix Co.	City of Industry, Calif.	14433	ITT Semiconductor, A Div. of Int. Telephone & Telegraph Corp.	West Palm Beach, Fla.
02286	Cole Rubber and Plastics Inc.	Sunnyvale, Calif.	07256	Silicon Transistor Corp.	Carle Place, N. Y.	14493	Hewlett-Packard Company	Leveland, Colo.
02660	Amphenol-Borg Electronics Corp.	Chicago, Ill.	07261	Avnet Corp.	Culver City, Calif.	14655	Cornell Dublier Electric Corp.	Newark, N. J.
02735	Radio Corp. of America, Semiconductor and Materials Div.	Somerville, N. J.	07263	Fairchild Camera & Inst. Corp. Semiconductor Div.	Mountain View, Calif.	14674	Corning Glass Works	Corning, N. Y.
02771	Vocaline Co. of America, Inc.	Old Saybrook, Conn.	07322	Minnesota Rubber Co.	Minneapolis, Minn.	14752	Electro Cube Inc.	San Gabriel, Calif.
02777	Hopkins Engineering Co.	San Fernando, Calif.	07387	Birtcher Corp., The	Monterey Park, Calif.	14960	Williams Mfg. Co.	San Jose, Calif.
03508	G. E. Semiconductor Prod. Dept.	Syracuse, N. Y.	07397	Sylvania Elect. Prod. Inc., Mt. View Operations	Mountain View, Calif.	15203	Webster Electronics Co.	New York, N. Y.
03705	Apex Machine & Tool Co.	Dayton, Ohio	07700	Technical Wire Products Inc.	Cranford, N. J.	15287	Scionics Corp.	Northridge, Calif.
03797	Eldema Corp.	Compton, Calif.	07825	Bodine Elect. Co.	Chicago, Ill.	15291	Adjustable Bushing Co.	N. Hollywood, Calif.
03818	Parker Seal Co.	Los Angeles, Calif.	07910	Continental Device Corp.	Hawthorne, Calif.	15558	Micron Electronics	Garden City, Long Island, N. Y.
03877	Transitron Electric Corp.	Wakefield, Mass.	07933	Raytheon Mfg. Co., Semiconductor Div.	Mountain View, Calif.	15566	Amprobe Inst. Corp.	Lynbrook, N. Y.
03888	Pyrolim Resistor Co., Inc.	Cedar Knolls, N. J.	07980	Hewlett-Packard Co., Boonton Radio Div.	Rockaway, N. J.	15631	Cabletronics	Costa Mesa, Calif.
03954	Singer Co., Diehl Div. Finnerde Plant	Somerville, N. J.	08145	U. S. Engineering Co.	Los Angeles, Calif.	15772	Twentieth Century Coil Spring Co.	Santa Clara, Calif.
04009	Arrow, Hart and Hegeman Elect. Co.	Hartford, Conn.	08289	Blinn, Delbert Co.	Pomona, Calif.	15801	Fenwal Elect. Inc.	Framingham, Mass.
04013	Taurus Corp.	Lambertville, N. J.	08358	Burgess Battery Co.	Niagara Falls, Ontario, Canada	15818	Amelco Inc.	Mt. View, Calif.
04062	Arco Electronic Inc.	Great Neck, N. Y.	08524	Deutsch Fastener Corp.	Los Angeles, Calif.	16037	Spruce Pine Mica Co.	Spruce Pine, N. C.
04222	Hi-Q Division of Aerovox	Myrtle Beach, S. C.	08664	Bristol Co., The	Waterbury, Conn.	16179	Omni-Spectra Inc.	Detroit, Ill.
04354	Precision Paper Tube Co.	Wheeling, Ill.	08717	Sloan Company	Sun Valley, Calif.	16352	Computer Diode Corp.	Lodi, N. J.
04404	Dymec Division of Hewlett-Packard Co.	Palo Alto, Calif.	08718	ITT Cannon Electric Inc., Phoenix Div.	Phoenix, Arizona	16688	Ideal Prec. Meter Co., Inc.	Brooklyn, N. Y.
04651	Sylvania Electric Products, Microwave Device Div.	Mountain View, Calif.	08727	National Radio Lab. Inc.	Paramus, N. J.	16758	Delco Radio Div. of G. M. Corp.	Kokoma, Ind.
04713	Motorola, Inc., Semiconductor Prod. Div.	Phoenix, Arizona	08792	CBS Electronics Semiconductor Operations, Div. of C. B. S. Inc.	Lowell, Mass.	17109	Thermonetics Inc.	Canoga Park, Calif.
04732	Filttron Co., Inc. Western Div.	Culver City, Calif.	08984	Mel-Rain	Indianapolis, Ind.	17474	Tranex Company	Mountain View, Calif.
04773	Automatic Electric Co.	Northlake, Ill.	09026	Babcock Relays Div.	Costa Mesa, Calif.	17675	Hamlin Metal Products Corp.	Akron, Ohio
04796	Sequoia Wire Co.	Redwood City, Calif.	09134	Texas Capacitor Co.	Houston, Texas	17745	Angstrom Prec. Inc.	No. Hollywood, Calif.
04811	Precision Coil Spring Co.	El Monte, Calif.	09145	Tech. Ind. Inc. Atomb Elect.	Burbank, Calif.	17870	McGraw-Edison Co.	Manchester, N. H.
04870	P. M. Motor Company	Westchester, Ill.	09250	Electro Assemblies, Inc.	Chicago, Ill.	18042	Power Design Pacific Inc.	Palo Alto, Calif.
04919	Component Mfg. Service Co.	W. Bridgewater, Mass.	09569	Mallory Battery Co. of Canada, Ltd.	Toronto, Ontario, Canada	18083	Clevite Corp., Semiconductor Div.	Palo Alto, Calif.
05006	Twentieth Century Plastics, Inc.	Los Angeles, Calif.	10214	General Transistor Western Corp.	Los Angeles, Calif.	18324	Signetics Corp.	Sunnyvale, Calif.
05277	Westinghouse Electric Corp. Semi-Conductor Dept.	Youngwood, Pa.				18476	Ty-Car Mfg. Co., Inc.	Holliston, Mass.

## CODE LIST OF MANUFACTURERS (Cont'd)

Code No.	Manufacturer	Address	Code No.	Manufacturer	Address	Code No.	Manufacturer	Address
19500	Thomas A. Edison Industries, Div. of McGraw-Edison Co.	West Orange, N. J.	70998	Bird Electronic Corp.	Cleveland, Ohio	76210	C. W. Marwedel	San Francisco, Calif.
19589	Concoa	Baldwin Park, Calif.	71002	Birnback Radio Co.	New York, N. Y.	76433	General Instrument Corp., Micamold Division	Newark, N. J.
19644	LRC Electronics	Horseheads, N. Y.	71034	Bliley Electric Co., Inc.	Erie, Pa.	76487	James Millen Mfg. Co., Inc.	Malden, Mass.
19701	Electra Mfg. Co.	Independence, Kansas	71041	Boston Gear Works Div. of Murray Co. of Texas	Quincy, Mass.	76493	J. W. Miller Co.	Los Angeles, Calif.
20183	General Altronics Corp.	Philadelphia, Pa.	71218	Bud Radio, Inc.	Willoughby, Ohio	76530	Cinch-Monadeck, Div. of United Carr Fastener Corp.	San Leandro, Calif.
21226	Excutoone, Inc.	Long Island City, N. Y.	71279	Cambridge Thermionics Corp.	Cambridge, Mass.	76545	Mueller Electric Co.	Cleveland, Ohio
21335	Fafair Bearing Co., The	New Britain, Conn.	71286	Camloc Fastener Corp.	Paramus, N. J.	76703	National Union	Newark, N. J.
21520	Fansleel Metallurgical Corp.	N. Chicago, Ill.	71313	Cardwell Condenser Corp.	Lindenhurst L. I., N. Y.	76854	Oak Manufacturing Co.	Crystal Lake, Ill.
23783	British Radio Electronics Ltd.	Washington, D. C.	71400	Bussmann Mfg. Div. of McGraw-Edison Co.	St. Louis, Mo.	77068	The Bendix Corp., Electrodynamic Div.	N. Hollywood, Calif.
24455	G. E. Lamp Division	Nela Park, Cleveland, Ohio	71436	Chicago Condenser Corp.	Chicago, Ill.	77075	Pacific Metals Co.	San Francisco, Calif.
24655	General Radio Co.	West Concord, Mass.	71447	Calif. Spring Co., Inc.	Pico-Rivera, Calif.	77221	Phanosrae Instrument and Electronic Co.	South Pasadena, Calif.
24681	Memcor Inc., Comp. Div.	Huntington, Ind.	71450	CTS Corp.	Elkhart, Ind.	77252	Philadelphia Steel and Wire Corp.	Philadelphia, Pa.
26365	Gries Reproducer Corp.	New Rochelle, N. Y.	71468	ITT Cannon Electric Inc.	Los Angeles, Calif.	77342	American Machine & Foundry Co. Potter & Brumfield Div.	Princeton, Ind.
26462	Grobet File Co. of America, Inc.	Carlstadt, N. J.	71471	Cinema, Div. Aerovox Corp.	Burbank, Calif.	77630	TRW Electronic Components Div.	Camden, N. J.
26851	Compac/Hollister Co.	Hollister, Calif.	71482	C. P. Clare & Co.	Chicago, Ill.	77638	General Instrument Corp., Rectifier Div.	Brooklyn, N. Y.
26992	Hamilton Watch Co.	Lancaster, Pa.	71590	Centralab Div. of Globe Union Inc.	Milwaukee, Wis.	77764	Resistance Products Co.	Harrisburg, Pa.
28480	Hewlett-Packard Co.	Palo Alto, Calif.	71616	Commercial Plastics Co.	Chicago, Ill.	77969	Rubbercraft Corp. of Calif.	Torrance, Calif.
28520	Heyman Mfg. Co.	Kenilworth, N. J.	71700	Cornish Wire Co., The	New York, N. Y.	78189	Shakeproof Division of Illinois Tool Works	Elgin, Ill.
30817	Instrument Specialties Co., Inc.	Little Falls, N. J.	71707	Coto Coil Co., Inc.	Providence, R. I.	78277	Sigma	So. Braintree, Mass.
33173	G. E. Receiving Tube Dept.	Owensboro, Ky.	71744	Chicago Miniature Lamp Works	Chicago, Ill.	78283	Signal Indicator Corp.	New York, N. Y.
35434	Lectrohm Inc.	Chicago, Ill.	71785	Cinch Mfg. Co., Howard B. Jones Div.	Chicago, Ill.	78290	Struthers-Dunn Inc.	Pitman, N. J.
36196	Stanwyck Coil Products Ltd.	Hawkesbury, Ontario, Canada	71984	Dow Corning Corp.	Midland, Mich.	78452	Thompson-Bremer & Co.	Chicago, Ill.
36287	Cunningham, W. H. & Hill, Ltd.	Toronto Ontario, Canada	72136	Electro Motive Mfg. Co., Inc.	Williamant, Conn.	78471	Tilley Mfg. Co.	San Francisco, Calif.
37942	P. R. Mallory & Co. Inc.	Indianapolis, Ind.	72619	Dialight Corp.	Brooklyn, N. Y.	78488	Stackpole Carbon Co.	St. Marys, Pa.
39543	Mechanical Industries Prod. Co.	Akron, Ohio	72656	Indiana General Corp., Electronics Div.	Keasby, N. J.	78493	Standard Thomson Corp.	Waltham, Mass.
40920	Miniature Precision Bearings, Inc.	Keene, N. H.	72699	General Instrument Corp., Cap. Div.	Newark, N. J.	78553	Tinnerman Products, Inc.	Cleveland, Ohio
42190	Muter Co.	Chicago, Ill.	72765	Drake Mfg. Co.	Harwood Heights, Ill.	78790	Transformer Engineers	San Gabriel, Calif.
43990	C. A. Norgren Co.	Eaglewood, Colo.	72825	Hugh H. Eby Inc.	Philadelphia, Pa.	78947	Ucinite Co.	Newtonville, Mass.
44655	Ohmite Mfg. Co.	Skokie, Ill.	72928	Gudeman Co.	Chicago, Ill.	79136	Waldes Kohinor Inc.	Long Island City, N. Y.
46384	Penn Eng. & Mfg. Corp.	Daylestown, Pa.	72962	Elastic Stop Nut Corp.	Union, N. J.	79142	Veeder Root, Inc.	Hartford, Conn.
47904	Polaroid Corp.	Cambridge, Mass.	72964	Robert M. Hadley Co.	Los Angeles, Calif.	79251	Wenco Mfg. Co.	Chicago, Ill.
48620	Precision Thermometer & Inst. Co.	Southampton, Pa.	72982	Erie Technological Products, Inc.	Erie, Pa.	79727	Continental-Wirt Electronics Corp.	Philadelphia, Pa.
49956	Microwave & Power Tube Div.	Waltham, Mass.	73061	Hansen Mfg. Co., Inc.	Princeton, Ind.	79963	Zierick Mfg. Corp.	New Rochelle, N. Y.
52090	Rowan Controller Co.	Westminster, Md.	73076	H. M. Harper Co.	Chicago, Ill.	80031	Mepco Division of Sessions Clock Co.	Morristown, N. J.
52983	Sanborn Company	Waltham, Mass.	73138	Helipot Div. of Beckman Inst., Inc.	Fullerton, Calif.	80120	Schnitzer Alloy Products Co.	Elizabeth, N. J.
54294	Shallcross Mfg. Co.	Selma, N. C.	73293	Hughes Products Division of Hughes Aircraft Co.	Newport Beach, Calif.	80131	Electronic Industries Association. Any brand Tube meeting EIA Standards-Washington, DC.	Washington, DC.
55026	Simpson Electric Co.	Chicago, Ill.	73445	Ampertex Elect. Co.	Hicksville, L. I., N. Y.	80207	Unimax Switch, Div. Maxon Electronics Corp.	Wallingford, Conn.
55933	Sonotone Corp.	Elmsford, N. Y.	73506	Bradley Semiconductor Corp.	New Haven, Conn.	80223	United Transformer Corp.	New York, N. Y.
55938	Raytheon Co. Commercial Apparatus & Systems Div.	So. Norwalk, Conn.	73559	Carling Electric, Inc.	Hartford, Conn.	80248	Oxford Electric Corp.	Chicago, Ill.
56137	Spaulding Fibre Co., Inc.	Tenawanda, N. Y.	73586	Circle F Mfg. Co.	Trenton, N. J.	80294	Bouras Inc.	Riverside, Calif.
56289	Sprague Electric Co.	North Adams, Mass.	73682	George K. Garrett Co., Div. MSL Industries Inc.	Philadelphia, Pa.	80411	Acro Div. of Robertshaw Controls Co.	Columbus, Ohio
59446	Telex Corp.	Tulsa, Okla.	73734	Federal Screw Products Inc.	Chicago, Ill.	80486	All Star Products Inc.	Defiance, Ohio
59730	Thomas & Betts Co.	Elizabeth, N. J.	73743	Fischer Special Mfg. Co.	Cincinnati, Ohio	80509	Avery Label Co.	Monrovia, Calif.
60741	Triplett Electrical Inst. Co.	Bluffton, Ohio	73793	General Industries Co., The	Elyria, Ohio	80583	Hammarlund Co., Inc.	New York, N. Y.
61775	Union Switch and Signal, Div. of Westinghouse Air Brake Co.	Pittsburgh, Pa.	73846	Goshen Stamping & Tool Co.	Goshen, Ind.	80640	Stevens, Arnold, Co., Inc.	Boston, Mass.
62119	Universal Electric Co.	Owosso, Mich.	73899	JFD Electronics Corp.	Brooklyn, N. Y.	80613	Dimco Gray Co.	Dayton, Ohio
63743	Waid-Leonard Electric Co.	Mt. Vernon, N. Y.	73905	Jennings Radio Mfg. Corp.	San Jose, Calif.	81030	International Instruments Inc.	Orange, Conn.
64959	Western Electric Co., Inc.	New York, N. Y.	73957	Groov-Pin Corp.	Ridgefield, N. J.	81073	Grayhill Co.	LaGrange, Ill.
65092	Weston Inst. Inc. Weston-Newark	Newark, N. J.	74276	Signalite Inc.	Neptune, N. J.	81095	Triad Transformer Corp.	Venice, Calif.
66295	Witte Mfg. Co.	Chicago, Ill.	74455	J. H. Winns, and Sons	Winchester, Mass.	81312	Winchester Elec. Div. Litton Ind., Inc.	Dakville, Conn.
66346	Minnesota Mining & Mfg. Co.	Revere Mincom Div. St. Paul, Minn.	74861	Industrial Condenser Corp.	Chicago, Ill.	81349	Military Specification	El Segundo, Calif.
70276	Allen Mfg. Co.	Hartford, Conn.	74868	R. F. Products Division of Amphenol-Borg Electronics Corp.	Danbury, Conn.	81541	Airpax Electronics, Inc.	Cambridge, Maryland
70309	Allied Control	New York, N. Y.	74970	E. F. Johnson Co.	Waseca, Minn.	81860	Barry Controls, Div. Barry Wright Corp.	Watertown, Mass.
70318	Allmetal Screw Product Co., Inc.	Garden City, N. Y.	75042	International Resistance Co.	Philadelphia, Pa.	82042	Carter Precision Electric Co.	Skokie, Ill.
70417	Amplex, Div. of Chrysler Corp.	Detroit, Mich.	75263	Keystone Carbon Co., Inc.	St. Marys, Pa.			
70485	Atlantic India Rubber Works, Inc.	Chicago, Ill.	75378	CTS Knights Inc.	Sandwich, Ill.			
70563	Amperite Co., Inc.	Union City, N. J.	75382	Kulka Electric Corporation	Mt. Vernon, N. Y.			
70674	ADC Products Inc.	Minneapolis, Minn.	75818	Lenz Electric Mfg. Co.	Chicago, Ill.			
70903	Belden Mfg. Co.	Chicago, Ill.	75915	Littlefuse, Inc.	Des Plaines, Ill.			
			76005	Lord Mfg. Co.	Erie, Pa.			

From: FSC. Handbook Supplements  
H4-1 Dated AUGUST 1966  
H4-2 Dated NOV. 1962

## CODE LIST OF MANUFACTURERS (Cont'd)

Code No.	Manufacturer	Address	Code No.	Manufacturer	Address	Code No.	Manufacturer	Address
82047	Sperli Faraday Inc.	Copper Hewitt	88220	Gould-National Batteries, Inc.	St. Paul, Minn.	96067	Huggins Laboratories	Sunnyvale, Calif.
82142	Jeffers Electronics Division of Speer Carbon Co.	Hoboken, N.J. Du Bois, Pa.	88658	General Mills, Inc.	Buffalo, N.Y.	96095	Hi-Q Div. of Aerovox Corp.	Glean, N.Y.
82170	Fairchild Camera & Inst. Corp. Space & Defense System Div.	Paramus, N.J.	89231	Graybar Electric Co.	Oakland, Calif.	96256	Thordarson-Weissner Inc.	Mt. Carmel, Ill.
82209	Maguire Industries, Inc.	Greenwich, Conn.	89473	G.E. Distributing Corp.	Schenectady, N.Y.	96296	Solar Manufacturing Co.	Los Angeles, Calif.
82219	Sylvania Electric Prod. Inc. Electronic Tube Division	Emporium, Pa.	89665	United Transformer Co.	Chicago, Ill.	96330	Carlton Screw Co.	Chicago, Ill.
82376	Astron Corp.	East Newark, N.J.	90030	United Shoe Machinery Corp.	Beverly, Mass.	96341	Microwave Associates, Inc.	Burlington, Mass.
82389	Switchcraft, Inc.	Chicago, Ill.	90179	US Rubber Co., Consumer Ind. & Plastics Prod. Div.	Passaic, N.J.	96501	Excel Transformer Co.	Oakland, Calif.
82647	Metals & Controls Inc. Spencer Products	Attleboro, Mass.	90970	Bearing Engineering Co.	San Francisco, Calif.	97464	Industrial Retaining Ring Co.	Irvington, N.J.
82768	Phillips-Advance Control Co.	Joliet, Ill.	91146	ITT Cannon Elect. Inc., Salem Div.	Salem, Mass.	97539	Automatic & Precision Mfg.	Englewood, N.J.
82866	Research Products Corp.	Madison, Wis.	91260	Connor Spring Mfg. Co.	San Francisco, Calif.	97979	Reon Resistor Corp.	Yonkers, N.Y.
82877	Rotson Mfg. Co., Inc.	Woodstock, N.Y.	91345	Miller Dial & Nameplate Co.	El Monte, Calif.	97983	Litton System Inc., Adler-Westrex Comm. Div.	New Rochelle, N.Y.
82893	Vectra Electronic Co.	Glendale, Calif.	91418	Radio Materials Co.	Chicago, Ill.	98141	R-Tronics, Inc.	Jamaica, N.Y.
83058	Carr Fastener Co.	Cambridge, Mass.	91506	Augat Inc.	Attleboro, Mass.	98159	Rubber Teck, Inc.	Gardena, Calif.
83086	New Hampshire Ball Bearing, Inc.	Peterborough, N.H.	91637	Dale Electronics, Inc.	Columbus, Neb.	98220	Hewlett-Packard Co., Moseley Div.	Pasadena, Calif.
83125	General Instrument Corp., Capacitor Div.	Darlington, S.C.	91662	Elco Corp.	Willow Grove, Pa.	98278	Microdot, Inc.	So. Pasadena, Calif.
83148	ITT Wire and Cable Div.	Los Angeles, Calif.	91737	Gremar Mfg. Co., Inc.	Wakefield, Mass.	98291	Seslectro Corp.	Memorocock, N.Y.
83186	Victory Eng. Corp.	Springfield, N.J.	91827	K F Development Co.	Redwood City, Calif.	98376	Zero Mfg. Co.	Burbank, Calif.
83298	Bendix Corp., Red Bank Div.	Red Bank, N.J.	91886	Malco Mfg. Co., Inc.	Chicago, Ill.	98731	General Mills Inc., Electronics Div.	Minneapolis, Minn.
83315	Hubbell Corp.	Mundelein, Ill.	91929	Honeywell Inc., Micro Switch Div.	Freeport, Ill.	98734	Paeco Div. of Hewlett-Packard Co.	Palo Alto, Calif.
83324	Rosan Inc.	Newport Beach, Calif.	91961	Nahn-Bros. Spring Co.	Oakland, Calif.	98821	North Hills Electronics, Inc.	Glen Cove, N.Y.
83330	Smith, Herman H., Inc.	Brooklyn, N.Y.	92180	Tru-Connector Corp.	Peabody, Mass.	98978	International Electronic Research Corp.	Burbank, Calif.
83332	Tech Labs	Palisades Park, N.J.	92367	Edgett Optical Co. Inc.	Rochester, N.Y.	99109	Columbia Technical Corp.	New York, N.Y.
83385	Central Screw Co.	Chicago, Ill.	92607	Tensolite Insulated Wire Co., Inc.	Tarrytown, N.Y.	99313	Varian Associates	Palo Alto, Calif.
83501	Gawitt Wire and Cable Co. Div. of Amerace Corp.	Brookfield, Mass.	92702	IMC Magnetics Corp.	Westbury Long Island, N.Y.	99378	Allee Corp.	Winchester, Mass.
83594	Burroughs Corp. Electronic Tube Div.	Plainfield, N.J.	92966	Hudson Lamp Co.	Keamey, N.J.	99515	Marshall Ind., Capacitor Div.	Monrovia, Calif.
83740	Union Carbide Corp. Consumer Prod. Div.	New York, N.Y.	93032	Sylvania Electric Prod. Inc. Semiconductor Div.	Woburn, Mass.	99707	Control Switch Division, Controls Co. of America	El Segundo, Calif.
83777	Model Eng. and Mfg., Inc.	Huntington, Ind.	93369	Robbins & Myers Inc.	Palisades Park, N.J.	99800	Delevan Electronics Corp.	East Aurora, N.Y.
83821	Loyd Scruggs Co.	Festus, Mo.	93410	Stevens Mfg. Co., Inc.	Mansfield, Ohio	99848	Wilco Corporation	Indianapolis, Ind.
83942	Aeronautical Inst. & Radio Co.	Lodi, N.J.	93632	Waters Mfg. Co.	Culver City, Calif.	99934	Renbrandt, Inc.	Boston, Mass.
84171	Arco Electronics Inc.	Great Neck, N.Y.	93929	G.V. Controls	Livingston, N.J.	99942	Hoffman Electronics Corp. Semiconductor Div.	El Monte, Calif.
84396	A.J. Glesener Co., Inc.	San Francisco, Calif.	94137	General Cable Corp.	Bayonne, N.J.	99957	Technology Instrument Corp. of Calif.	Newbury Park, Calif.
84411	TRW Capacitor Div.	Ogallala, Neb.	94144	Raytheon Co., Comp. Div., Ind. Comp. Operations	Quincy, Mass.			
84970	Sarkes Tarzian, Inc.	Bloomington, Ind.	94154	Wagner Elect. Corp., Tung-Sol Div.	Newark, N.J.			
85454	Boonton Molding Company	Boonton, N.J.	94197	Curtiss-Wright Corp. Electronics Div.	East Paterson, N.J.			
85471	A.B. Boyd Co.	San Francisco, Calif.	94222	South Chester Corp.	Chester, Pa.			
85474	R.M. Bracamonte & Co.	San Francisco, Calif.	94330	Wire Cloth Products, Inc.	Bellwood, Ill.			
85660	Kolett Kords, Inc.	Hamden, Conn.	94375	Automatic Metal Products Co.	Brooklyn, N.Y.			
85911	Seal-ess Rubber Co.	Chicago, Ill.	94682	Worcester Pressed Aluminum Corp.	Worcester, Mass.			
86197	Clifton Precision Products Co., Inc.	Clifton Heights, Pa.	94696	Magnecraft Electric Co.	Chicago, Ill.			
86579	Precision Rubber Products Corp.	Dayton, Ohio	95023	George A. Philbrick Researchers, Inc.	Boston, Mass.			
86684	Radio Corp. of America, Electronic Comp. & Devices Div.	Harrison, N.J.	95236	Allies Products Corp.	Dania, Fla.			
87034	Marco Industries	Anaheim, Calif.	95238	Continental Connector Corp.	Woodside, N.Y.			
87216	Phico Corporation (Lansdale Division)	Lansdale, Pa.	95263	Leecraft Mfg. Co., Inc.	Long Island, N.Y.			
87473	Western Fibrous Glass Products Co.	San Francisco, Calif.	95265	National Coil Co.	Sheridan, Wyo.			
87664	Van Waters & Rogers Inc.	San Francisco, Calif.	95275	Vitramon, Inc.	Bridgeport, Conn.			
87930	Tower Mfg. Corp.	Providence, R.I.	95348	Gordos Corp.	Bloomfield, N.J.			
88140	Cutler-Hammer, Inc.	Lincoln, Ill.	95354	Methode Mfg. Co.	Rolling Meadows, Ill.			
			95566	Arnold Engineering Co.	Marengo, Ill.			
			95712	Dage Electric Co., Inc.	Franklin, Ind.			
			95984	Siemon Mfg. Co.	Wayne, Ill.			
			95987	Weckesser Co.	Chicago, Ill.			

THE FOLLOWING HP VENDORS HAVE NO NUMBER ASSIGNED IN THE LATEST SUPPLEMENT TO THE FEDERAL SUPPLY CODE FOR MANUFACTURERS HANDBOOK.

0000F	Malco Tool and Die	Los Angeles, Calif.
0000Z	Willow Leather Products Corp.	Newark, N.J.
000AB	ETA	England
000BB	Precision Instrument Components Co.	Van Nuys, Calif.
000CS	Hewlett-Packard Co., Colorado Springs	Colorado Springs, Colorado
000MM	Rubber Eng. & Development	Hayward, Calif.
000NN	A "N" D Mfg. Co.	San Jose, Calif.
000QQ	Cooltron	Oakland, Calif.
000WW	California Eastern Lab.	Burlington, Calif.
000YY	S.K. Smith Co.	Los Angeles, Calif.





# MANUAL BACKDATING CHANGES

MODEL 410C

ELECTRONIC VOLTMETER

 Manual Serial Prefixed: 807-  
 -hp- Part No. 00410-90005

This manual backdating sheet makes this manual applicable to earlier instruments. Instrument-component values that differ from those in the manual, yet are not listed in the backdating sheet, should be replaced using the part number given in the manual.

Instrument Serial Prefix      Make Manual Changes      Instrument Serial Prefix      Make Manual Changes

550- and below	1	344-	1 thru 6
550-05300 and below	1, 2	339-	1 thru 7
532-	1 thru 3	328-	1 thru 8
443-	1 thru 4	311-	1 thru 9

## CHANGE 1:

Under Table of Replaceable Parts:

Delete: A3C1 -hp- Part No. 0160-2641.

A3C2 -hp- Part No. 0160-3116.

Add: A3C1 -hp- Part No. 0170-0030.

A3C2 -hp- Part No. 0170-0077.

## CHANGE 2:

Under Table of Replaceable Parts:

Delete: A3C11; Capacitor: fixed, 100  $\mu$ f, 25 vdcw -hp- Part No. 0180-0094.Add: A3C11; Capacitor: fixed, 100  $\mu$ f, 50 vdcw -hp- Part No. 0180-1819.

## NOTE

Later Models 410C (Serial No. 550-05301 and above use a 50 vdcw capacitor (-hp- Part No. 0180-1819) to ensure that the voltage rating of the capacitor is not exceeded. It is recommended that earlier models be modified accordingly in case of failure of the 25 vdcw capacitor.

## CHANGE 3:

Under Table of Replaceable Parts:

Delete: C2; Capacitor: fixed, 0.1  $\mu$ f -hp- Part No. 0170-0022.Add: C2; Capacitor: fixed, 0.1  $\mu$ f -hp- Part No. 0160-0001.Add: R6; Resistor: fixed, 284 K  $\Omega$  -hp- Part No. 0727-0231.Add: R7; Resistor: fixed, 15 K  $\Omega$  -hp- Part No. 0727-0168.Add: R8; Resistor: variable, 10 K  $\Omega$  -hp- Part No. 2100-1567.Add: R9; Resistor: fixed, 25.5 K  $\Omega$  -hp- Part No. 0727-0180.

Figures 3-1, 3-2, 3-3, 3-7:

Delete:



Figures 4-3, 4-4, 4-5, 4-6:

Delete:

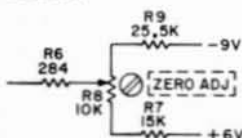
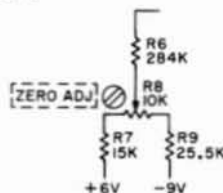

Figure 5-11, Amplifier Schematic:

Delete:



## Manual Backdating Changes Model 410C Page 2

## CHANGE 3 (Cont'd):

Page 5-1, Paragraph 5-11 a:

Short Model 410C DCV probe to COM lead; pointer should read zero. If not, refer to Paragraph 5-33 for adjustment procedure.

Page 5-8, Paragraph 5-34 c:

Adjust A3R21 for zero meter deflection.

Page 5-8, Paragraph 5-34 c:

Switch to -DCV. If any deflection is observed, adjust A3R21 to return meter pointer halfway back to zero. Check zero setting on all ranges for both +DCV and -DCV. Zero offset shall not exceed 1% in any case.

## NOTE

Later Models 410C (Serial Prefix 550 and above) use the ZERO ADJUST on the rear panel for increased accuracy for DC ZERO ADJUSTMENT. It is recommended that earlier models be modified accordingly. Refer to Service Note 410C-6 for modification instructions.

## CHANGE 4:

Under Table of Replaceable Parts:

Delete: A3R20; Resistor, fixed, 1 K ohm; Part No. 0687-1021.

Add: A3R20; Resistor, fixed, 10 K ohms; Part No. 0686-1035.

Figure 5-10, Amplifier Schematic:

Change A3R20 from 1 K ohm to 10 K ohms.

## NOTE

Later Models 410C (Serial Prefix 433 and above) use a 1 K ohm resistor for A3R20 to increase the meter zero adjustment (A3R21). It is recommended that earlier models be modified accordingly, in case of zero adjustment problem. Refer to Service Note 410C-1 for modification instructions.

## CHANGE 5:

Under Table of Replaceable Parts:

Delete: Q1; Transistor, PNP Germanium; Part No. 1850-0098.

Add: Q1; Transistor, PNP Germanium; Part No. 1850-0094.

## NOTE

Later Models 410C (Serial Prefix 433 and above) use the Part No. 1850-0098 for increased reliability. It is recommended that earlier models be modified accordingly, in case of failure of the earlier type transistor. Refer to Service Note 410C-3 for modification instructions.

## CHANGE 6:

Under Table of Replaceable Parts:

Delete: CR7; Diode, Breakdown Junction, 9 v, 1.5 w; Part No. 1902-0327.

Add: A7CR7; Diode, Breakdown Junction, 9 v, 0.4 w; Part No. 1902-0037.

Figure 5-8, Power Supply Schematic:

Change CR7 to A7CR7. This designates that this diode is part of the Power Supply Assembly, A7.

## NOTE

Later Models 410C (Serial Prefix 433 and above) use the 1.5 watt breakdown diode (Part No. 1902-0327) for increased reliability. It is recommended that earlier models be modified accordingly, in case of failure of the 0.4 watt diode.

## CHANGE 7:

Under Table of Replaceable Parts:

Delete: S3; Switch, pushbutton w/pilot light; Part No. 3101-0100.

Delete: DS1; Light, indicator, A1C neon; Part No. 1450-0106.

Delete: R5; Resistor, fixed, 68 K ohms; Part No. 0687-6831.

## CHANGE 7 (Cont'd):

Add: S3; Switch, pushbutton; ☞ Part No. 3130-0054.  
 Add: DS1; Light, indicator, NE-2H neon; ☞ Part No. 1450-0048.  
 Add: Bushing, panel; ☞ Part No. 5020-0883.  
 Add: Actuator, AC switch; ☞ Part No. 5040-0918.  
 Add: Bracket; AC switch; ☞ Part No. 410C-12C.  
 Add: R5; Resistor, fixed, 33 K ohms; ☞ Part No. 0687-3331.

## NOTE

Later Models 410C (Serial Prefix 344 and above) use the ☞ Part No. 3101-0100, pushbutton switch w/pilot light for increased reliability. It is recommended that this improved switch-pilot light assembly be used for replacement, in case of failure of the older type switch. Refer to ☞ Service Note P-3101-0100 for modification instructions.

## CHANGE 8:

Under Table of Replaceable Parts:

Delete: A3R3; Resistor, fixed, 100 ohms; ☞ Part No. 410C-26D.  
 Add: A3R4; Resistor, fixed, 94 ohms; ☞ Part No. 0727-0470.  
 Add: A3R6; Resistor, fixed, 6 ohms; ☞ Part No. 410C-26C.

Figure 5-10, Amplifier Schematic:

Change:

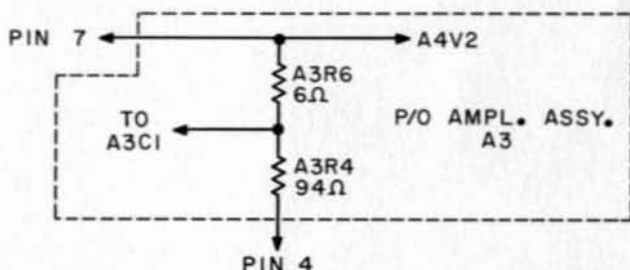

## CHANGE 9:

Under Table of Replaceable Parts:

Delete: A1R7; Resistor, fixed, 15 K ohms; ☞ Part No. 0687-1531.  
 Add: A1R7; Resistor, fixed, 22 K ohms; ☞ Part No. 0758-0020.  
 Delete: A2R2; Resistor, fixed, 10.5 ohms; ☞ Part No. 0727-0955.  
 Add: A2R2; Resistor, fixed, 6 megohms; ☞ Part No. 0727-0460.  
 Delete: A2R10; Resistor, fixed, 6 megohms; ☞ Part No. 0730-0176.  
 Add: A2R10; Resistor, fixed, 10.8 ohms; ☞ Part No. 0728-0005.

Figure 5-13, RANGE and FUNCTION Switching (Pictorial):

Change A1R7 from 15 K ohms to 22 K ohms.  
 Change A2R2 from 10.5 ohms to 6 megohms.  
 Change A2R10 from 6 megohms to 10.8 ohms.

