



SWR/WATT METER

Model TX-1202 User Manual

PRODUCT MAIN FEATURE

This wattmeter series offer many innovative features typically not found at this price level

- DC Grounded Antenna connector prevents electrostatic buildup.
- True Directional Coupler for increased accuracy over frequency.
- Low Bias Schottky Diode Detectors for increased linearity.
- Precision, large (104mm) Cross Needle Meter simultaneously displays forward and reflected power with SWR.
- Individual Meter Scales for each power range increase reading accuracy.
- LED backlighting provides smooth, even illumination.
- Three Color Scale for improved readability.
- Rugged metal cabinet with speckled black finish and designer style grey injection molded front panel aesthetically complements modern transceivers.
- DC Power Cable Included.

SPECIFICATIONS

Model	TX-1202		
Frequency Range	1.6 MHz - 1300 MHz		
Center Calibrated	28.5/145 MHz	435 MHz	1260 MHz
Power Range	0 - 200W		
Power Scale	2/20/200W		
Maximum Power	200W	20W	
Accuracy	± 10% of Full Scale or better		
Insertion loss	Less than 0.1 dB		
Min. Power (Forward)	1 W		
Testing Function	Forward Power, Reversed Power, SWR, PEP		
Input/Output Impedance	50 ohm		
Input/Output Connectors	M type for HF/VHF Band, N type for UHF Band		
Input power	9-14 VDC 200 mA (Max.)		
Dimension (W/H/D)	184 x 118 x 131 m/m		
Weight (Net)	1100 g		

<FRONT PANEL>

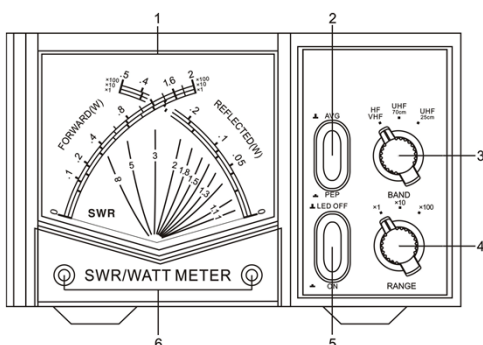

<DESCRIPTION>

1. Indicator Display : Indicates FWD/REV power in watts and VSWR ratio
2. AVG/PEP (elliptical) push button : Select AVG (out) or PEP (depressed)
3. Frequency switch : Select frequency measured
4. Range switch : Selects RF power range multiplier x1 x10 x100
5. LED ON/OFF button (elliptical) : Turn LED lamp
6. Zero adjust screws of analog cross needle meter

<REAR PANEL>

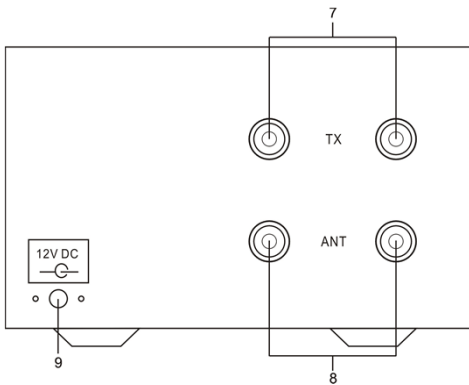

<DESCRIPTION>

7. TX connector : Coax connector to transmitter 50 ohm RF output
8. ANT connector : Coax connector to 50 ohm antenna system
9. 13.8V DC connection (via power supply) : LED illumination

Note 1 : Watch out the LED wire must be correctly connected, black/white to '+', Black to '-'.
Wrong connection burn LED)

Note 2 : DC power is only required to run the meter backlight. This meter will function w/o DC power in the AVG mode, even when switch off.

<INSTALLATION/OPERATION>

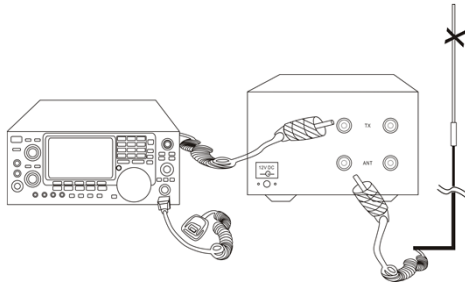

<FORWARD, REVERSE PWR, SWR MEASUREMENT>

- A. Set the RANGE switch to the proper meter multiplier (X1, X10, X100) for the expected power level of the intended measurement.
- B. In TX-1202, it corresponds to 2/20/200 watts forward and 0.5/5/50 watts reflected full scale (Fwd : Ref = 4 : 1)
- C. Select the frequency needed (**HF/VHF/UHF amateur bands**)
- D. Set the radio transceiver to transmit mode and read the scale corresponding to the RANGE selected
- E. When switch to 'AVG', the meter reads average RF power. When switch to 'PEP', the meter reads Peak Envelope Power for use with SSB and AM transmissions. In this mode, there will be a slow rise and decay time.
- F. Push LED ON/OFF button when LED light is needed.

[CAUTION]

1. Since the meter movement is very sensitive, avoid excessive vibration or mechanical shock to the meter.
2. Watch the absolute maximum power could be applied to the meter by different models you bought.
3. The meter must never be reverse connected. Always observe the correct connections to transmitter and antenna as indicated on the rear sockets.
4. Do not expose the meter to excessive temperatures, high humidity, or strong magnetic fields.
5. Contact your local dealer for service. Dealer information is in the back of user manual.