

TEN-TEC INSTRUCTION SHEET

MODEL KR50

UNPACKING

Carefully remove your KR50 from the packing carton and examine it for signs of shipping damage. Should any shipping damage be apparent, notify the delivering carrier or dealer immediately, stating the full extent of the damage. It is recommended that you keep the shipping cartons. In the event that, storage, moving, or reshipment becomes necessary, they come in handy. Make sure you haven't overlooked anything.

GENERAL

The KR50 Ultramatic Keyer is a solid state, integrated circuit keyer incorporating a reed relay as the actual keying component. It can be used to key all grid-blocked keying systems as well as many cathode keyed transmitters, limited as outlined later by the 15 volt-ampere contact rating. For high current keying circuits the KR50 can key an intermediate power relay. Because of the extremely low contact resistance of the reed relay when closed, (not possible with solid state switches), this keyer is ideally suited to key very low impedance and/or low voltage keying lines, such as those encountered in transistorized equipment.

The KR50 design provides maximum flexibility for the discerning cw operator so that it can be set to complement your operating style and preference. Individually defeatable dit and dah memories enable the keyer to be used in a full iambic squeeze keyer or as a straight electronic keyer with or without dit memory. Weighting can be fixed light or heavy, or be made to vary as speed is changed, resulting in highest articulation and rhythm at all speeds. The paddles are pivoted on low friction ball bearings, and return force is accomplished through the adjustable electromagnetic TOUCH control. In addition, a "straight key" button switch is conveniently located on the top of the unit which can be used for tune-up, QRS sending or emphasis. Characters are self-completing. The internal sidetone oscillator has a fixed output level. The KR50 can be powered from either the 117 volt AC line or from 6 to 14 volts DC.

SPECIFICATIONS

Keyed Output:	Reed Relay; 15 volt-amp contactn, 400 volts, max.
Speed Range:	6 to 50 WPM.
Time Base :	Keyed to start with paddle actuation.
Character Generation:	Self-completing dits and dahs.
Weighting Ratio Range:	50 % to 150 % of classical dit length. Can be pre-set for all speed settings, or be made to vary with speed.
Paddle Actuation Force:	Adjustable from 5 to 50 grams.
Side Tone:	Sawtooth waveform. Approx. 1 volt peak-to-peak. Frequency approx. 500 Hz, output impedance 15 Ω.
Memories:	Dit and dah, each individually defeatable.
Power:	105–125 VAC, 50–60 Hz or 6–14 VDC @ 200–300 mA.
Semiconductors:	5 Integrated Circuits, 9 Transistors, 7 Diodes.
Size:	HWD 2-1/2" × 5-1/2" × 8-1/4"
Weight:	1¾ lbs.

OPERATION

Controls - Front Panel

- POWER:** Push-on-push-off type. Operate only in AC mode. If DC power is used, switch is inoperative and keyer is "on" as long as DC power is supplied.
- SPEED:** Continuously variable between 6 and 50 WPM.
- CONTACT SPACING:** Slotted screw adjustments accessible through two small holes in top of unit. Dah contacts to right, dit contacts to left of touch button. clockwise rotation decreases spacing.
- OVER-RIDE SWITCH:** Touch button located on top of lip of case. Momentary contact type.
- PILOT:** Indicator for either AC or DC operation.

Controls and Connections - Rear Panel

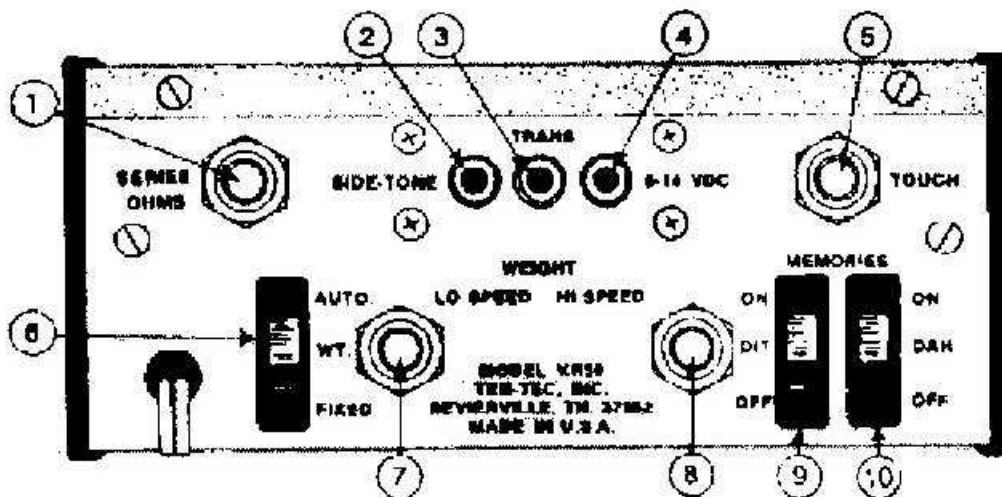

- 1.) **SERIES OHMS:** Provides resistance in series with the key line to prevent relay contacts from welding together. (Zero resistance in full CCW position.)
- 2.) **SIDE-TONE:** Output jack of internal audio oscillator. Connect to external headphones, speaker or receiver audio channel.
- 3.) **TRANS:** Keyed output jack. Whenever a character is sent, center terminal of jack is shorted to chassis ground. At other times, an open circuit is presented. Connect this jack to the transmitter KEY jack. It is advisable to use shielded cable to prevent RF pickup.
- 4.) **6-14 VDC:** DC power input jack if operation from DC voltage is desired. Center terminal is +, chassis is ground. A steering diode is incorporated in this circuit so that the unit will automatically be powered from the higher DC source if both AC and DC are applied to the unit simultaneously.
- 5.) **TOUCH:** This control determines the amount of current flowing through the paddle return force electromagnets. When fully counterclockwise, no current is applied and the only return force is that of the gravitational pull on the contact armatures. In some cases even this very small force is all that is required for proper paddle operation. However, if the keyer is placed on a surface other than level, or because of the small residual friction due to the bearing lubricant, operation with no magnet current may be erratic. It is recommended therefore that at least a small amount of clockwise rotation of the TOUCH control be used, enough to insure consistent keying.

6, 7, 8.) WT Switch and LO and HI SPEED Adjustments: The WT switch selects between automatic (AUTO) or FIXED weighting operation. LO SPEED control increases weighting and HI SPEED control decreases it.

Before proceeding with set-up instructions for these controls, let us take a moment to define several of the terms used. As given in the ARRL Handbook, the basic code element is the dot, or unit time pulse. By using this time element as the unit by which we measure all other code characteristics, our definitions will be independent of code speed, since we are talking of ratios and not actual time spans. What is referred to as "classical" code, then, is a dot length equal to one time element, a space between characters also equal to one unit, a dash equal to three units, the space between letters equal to three units and the space between words or groups equal to seven units. For our discussion, let us define this unit classical dot as one bit. If we have what is called a heavily weighted character, we have a dit that is somewhat longer than one bit and a dah somewhat longer than three bits. Conversely a lightly weighted character is a dit somewhat less than one bit in length, and a dah somewhat less than three bits in duration. Keep in mind that the space between characters is not changed when defining heavily and lightly weighted characters. (It can be seen that if a dit is weighted heavily enough, it can become a classical dah, and if a dah is weighted lightly enough, it becomes a dit. However, we do not deal in such large amounts of weighting.) We define the amount of weighting as the percent of a classical dit, with classical dit being 100 %. Therefore a dit length equal to one half of a classical dit, or one half of a bit, would be weighted 50 % and a heavily weighted dit equal to one and one half bits in length

Since most modern keyers operate from a time base oscillator whose speed is constant for a given setting of the SPEED control, an increase in the dit weighting will be accompanied by a shortening of the space after the dit, so as to maintain this constant speed. And since these keyers construct a dah by adding two dits and the space between them together, we can see that the weighted dah will be lengthened or shortened from the classical three bits, but to a lesser degree than the dit. In the case of our 150 % dit, equal to 1½ bits, the equivalent dah will be 3½ bits long instead of the classical three bits. This is a lengthening of only 17 %, one third as much as the dit.

It is generally agreed that slowly sent classical code sounds a bit choppy. Weighting on the heavy side provides a more rhythmic sound. Conversely, high speed classical code tends to run together making copying more difficult. Lightly weighted code in these instances is more clearly defined, since the dits are sharper pulses which come through more articulately.

With these factors in mind, we can proceed to set up the weighting controls. Make all adjustments while sending a string of dits. If you do not change your sending speed very much from contact to contact, the fixed weighting mode would complement your operating style. Set the WT switch to the FIXED position. With both LO and HI SPEED controls fully counter-clockwise, the weighting will be approximately at the classical setting. If weighting heavier than this is desired, rotate the LO SPEED control clockwise while sending a string of dits until the desired sound is achieved. If light weighting is desired, rotate the HI SPEED control clockwise. The setting so arrived at will be maintained no matter where the SPEED control is set. In the FIXED mode, only one or the other of the controls should be advanced from the full CCW positions.

If your sending style is to change speeds to match that of the station being worked, and the variable weighting feature of the KR50 is desired, set the WT switch to the AUTO position. As a starting point, set both LO and HI controls fully CCW. Adjust the SPEED control to the lowest speed you wish to work. If heavier weighting is desired, advance the LO SPEED control as needed. If you prefer a light weighting, advance the HI SPEED control. Now readjust the SPEED control to the fastest speed you expect to work. If your low speed adjustment was made with the LO SPEED control, set the HI SPEED control for the desired weight. If the low speed adjustment was made with the HI SPEED control, you only need to check operation at the fast speed, since weighting will already lighten at the fast speed. If the weighting change between your low and fast speeds is not suitable, the HI SPEED control should be reset to a position where the range is acceptable. If the low speed knob setting of the SPEED control is

more than half rotation, i.e. to the right of the 12 o'clock position, recheck the low speed weighting, since there is some interaction between the controls when the SPEED control is not at its extremes. (In some instances, where your slow and fast speed limits are a small part of the complete SPEED control range and where the weighting controls are advanced to near full clockwise rotation, you may find that the weighting is so extreme at the low and high speed limits that the keyer will lock on or off at these extremes. This is normal and is of no concern, since operation at these speeds is not contemplated.)

Since weighting preference is a personal factor, and is the result of what sounds best to you, setting up the controls by listening to the code is preferred. If, however, you would like to take a more scientific approach to weight adjustments, a meter method is given in the appendix.

- 9.) DIT MEMORY: This switch determines whether the dit memory is inserted in the circuit or not. In the ON position, a dit can be programmed to follow any dah, in correct spacing and sequence, if the dit paddle is momentarily actuated while a dah is being sent. Dits can be inserted between a string of dahs without releasing the dah paddle. For example, in sending the letter Q, the dah paddle is depressed and held. During the sending of the second dah, the dit paddle is actuated just momentarily. When you hear the third dah starting, after the dit ends, release the dah paddle, and the Q will be generated perfectly. Other letters, such as Y, K, and G can similarly make use of the dit memory and insertion technique, with DIT MEMORY on and the DAH MEMORY off, actuating both paddles simultaneously will result in a string of dits being generated. If the dah paddle is actuated a little before the dit paddle, a dah followed by a string of dits will result.

With the DIT MEMORY switch in the off position, the only time a dit can be sent is when the keyer is not generating dahs.

- 10.) DAH MEMORY: This memory is similar in operation to the dit memory. Dahs can be inserted between a string of dits, and such letters as P, L, U, V and R can use this technique.

Iambic Squeeze Keying - If both dit and dah memories are used, the keyer will perform as an iambic squeeze keyer. By actuating both paddles simultaneously, the memories will alternately program in dits and dahs so that a string of dit-dahs results. If the dit paddle is depressed a bit before the dah paddle, the string will start with a dit; if the dah paddle is actuated first, the string will start with a dah. Such letter as A, C, K, N, X and R can be formed with one squeeze motion of the fingers. Other letters such as F, I,, Q and Y can utilize the insertion technique as outlined above for reduced hand motions and easier sending of more perfect code.

CIRCUIT DESCRIPTION

Referring to the block diagram and plug-in assembly schematic, Q1, Q2 and Q3 constitute a timing oscillator whose frequency is determined by C1 and the series combination of R1 and SPEED potentiometer, R24B. The oscillator is switched on and off from logic circuitry signals fed to the emitter of Q1 via gate 4-2. At the instant Q1 is turned on, C1 discharges immediately through transistors Q2 and Q3. The voltage at the collector of Q1 drops from a high to low state and linearly starts to charge back to the high state. The initial drop in this voltage is passed on to the base of Q4 through the weighting resistance network, R24A, R25, R26 and R27. Q4 turns off which in turn turns gate 4-1 on. The low state of this gate is passed on to the relay driver transistor, Q5, through D1, closing the relay. This state remains until the ramp voltage on the base of Q4 reaches the turn-on level for this transistor, which then causes gate 4-1 to change state. In turn, Q5 reverts to the non-conducting state, providing flip-flop, IC-5, is not keeping the base voltage low through D2. This is the case if a dit was sent. If a dah was initiated, IC-5 would have been enabled through a logic signal applied to the set terminal, pin 8, and the relay would remain closed due to pin 10 becoming low. The dah logic would also keep the oscillator running. A reset pulse is generated at the base of Q2 and applied through gate 4-4 to the logic so that the circuit reverts to the initial state after completion of the character. Basically, the timing oscillator applies the dit pulse to the relay

driver and the dah is formed by having the oscillator send two dits to the driver transistor with the flip-flop 1C filling in the space between the two dits.

The length of the dit, hence its weighted value, is determined by selecting the voltage along the ramp voltage at which Q4 starts to conduct. The potentiometers in the weighting network serve to select this variable, and through coupling of this network to the SPEED control, the variable weighting function is achieved. For fixed weighting, the WT switch shorts potentiometer, R24A.

The side-tone oscillator consists of unijunction oscillator, Q6, driving a darlington emitter follower, Q7 and Q8. The unijunction is keyed "on" by changing the bias via relay driver transistor, Q5.

Power of 5 VDC for the keyer is developed through regulator transistor, Q9, which is governed in its output value by zener diode, D7, in its base circuit. DC voltage to the regulator may be from either an external DC voltage applied to Q9 collector through steering diode, D6, or from the power transformer/rectifier components in the keyer. The AC primary circuit is protected with a 1/4 amp, slo-blo pigtail fuse, mounted on a terminal strip internally. In some units, the power transformer secondary may be a single winding, resulting in a half wave rectifier configuration.

REED RELAY PROTECTION

Most commercial vacuum tube transmitter and/or transceivers use a form of grid block keying. The voltage present at the key terminals varies from a few volts to several hundred volts. The current being keyed is usually small. The steady state voltage and current are easily handled by the reed contacts. In some transmitters a capacitor is placed across the key line for by-pass purposes. The energy stored in this capacitor is released across the keyer relay contacts whenever the transmitter is keyed. Depending on the circuit constants, the surge current can exceed the ratings of the contacts, which may result in welded-together contacts. Since this is a high impedance circuit, a small resistor can be connected in series with the keyer relay output to limit the transient current surge to a safe value without affecting the operation of the transmitter. The SERIES OHMS control on the rear panel provided this current limiting function. It is a 250 ohm rheostat. For grid block keying transmitters, normal range of this control is from half to full CW position. For solid state and low voltage key lines, full CCW to one half rotation is normal. (ALL TEN-TEC transceivers should use full CCW position.) If keying system of your transmitter is unknown, start with control fully clockwise and reduce resistance until reliable keying and full output is attained. If relay in keyer exhibits contact sticking, increase SERIES OHMS setting clockwise until reliable keying is achieved.

When cathode keyed transmitters are used with the KR50, determine if the volt-ampere ratings are being exceeded by multiplying the key-up cathode voltage by the key-down cathode current. This product should be less than 15 to be within ratings. If it is higher, an intermediate power relay should be used. e.g. Key-up cathode voltage = 50 volts and key-down cathode current = 200 mA. $E \times I = 50 \times .2 = 10$ volt-amps. Within ratings.

INCREASING MAXIMUM SPEED

To increase the maximum speed of the KR50 to a value higher than 50 WPM, replace R1 on the top PC assembly with a resistor of a lesser value. A 2k7 resistor will increase the maximum to approximately 90 WPM. Values between 4k7 and 2k7 will affect the speed in between 50 and 90 WPM. The lowest speed of about 6 WPM will not be materially affected by this change. The increased speed range resulting from this modification may be somewhat more difficult to adjust accurately. To compensate for this, you may wish to increase the minimum speed as detailed below.

INCREASING MINIMUM SPEED

To increase the minimum speed at full CCW setting of the SPEED control, R24B may be shunted with an appropriate resistor from wiper terminal to ground. A 27k resistor shunting the control will increase the slowest speed from 6 to approximately 9 WPM. It is not recommended that too severe a change in minimum speed be attempted if the AUTO weighting feature is used. Shunting the speed potentiometer with a fixed resistor changes the taper of the control, and since the auto weighting circuit gangs two potentiometers together, the tracking of weight change from low to high speed will be affected. If fixed weighting is used, the minimum speed modification will not affect weighting, and any amount of change can be accommodated. R24B is the front section of the dual SPEED control.

SIDE-TONE OSCILLATOR

To lower the frequency of the side-tone, C9 on the plug-in assembly can be increased; to raise frequency, decrease the value of C9. The change will be on a direct ratio, i.e. doubling C9 to 0.2 mfd will result in halving the frequency to about 250 Hz.

AC LINE BY-PASS CAPACITORS

To provide good RF protection to the keyer circuits from possible RF pickup on the AC line, both sides of the incoming line are by-passed to keyer chassis with .01 mfd, 1 kV capacitors. Since one side of the AC line is already at a good earth ground, no matter what the polarity is of the line cord plug.

If the common station system ground plane, i.e. the chassis system, is not tied to a good earth ground, it will rise to an AC potential of about one half of the two capacitors. Under these conditions, a slight tingle may be encountered when touching any part of this pseudo ground and the real earth ground that may be present on other equipment in the shack. A lethal shock hazard is negligible since the amount of current that can be drawn through the high impedance of the .01 mfd capacitor is very small. But the presence of this tingle should alert you to the fact that your grounding system is not the best. **IT IS ALWAYS GOOD PRACTICE TO TIE THE STATION CHASSIS SYSTEM TO A GOOD EARTH GROUND.** Under these conditions, there will be no potential difference between units and tingle and shock hazard will not be present.

FUSE REPLACEMENT

The primary AC circuit of the KR50 is protected with a 1/4 ampere, slo-blo pigtail fuse which is permanently wired in the unit. Should it need replacing, remove the top and right side panel. Clip out the old fuse and replace with an identical type, or use an adapter and landless fuse clipped to the burned out fuse- Adapters are available from any parts distributor.

PADDLE CARE

Even though the mechanical paddle suspension system of the KR50 is rugged, reasonable care should be taken to preserve the delicate feel and fine performance capable from the unit. The ball bearings are hardened steel, but because of the very small displacements encountered, a sharp blow to the paddle may cause the balls to deform slightly, or cause the aluminum shaft to become loose from the bearing assembly. A good test of freeness in the system is to turn the TOUCH control fully CCW. Then by turning the keyer first vertically one way and then the other, the gravitational pull created by the paddles being eccentric to the shafts should be enough to key the keyer

on in both positions – dits in one and dahs in the other. (The approximate torque force on the shafts under this test is 4 grams at the center of the paddle finger area.)

The ball bearings should not be lubricated at any time. Factory lubrication should last the lifetime of the keyer.

LEFT-HANDED CW OPERATORS

If you wish to switch the dit and dah paddles, remove the top of the unit. Remove the top PC assembly and locate the brown and violet wires on the PC socket next to the power transformer. The brown lead should be one pin to the rear of the keyer from the center terminal, and the violet lead one pin to the front. Unsolder these two leads and interchange them. Resolder and reassemble the keyer.

PC BOARD ORIENTATION

Two plug-in PC assemblies constitute most of the circuitry, with the exception of controls, switches and power transformer. The two plug-ins are mounted one above the other. The top assembly contains all logic, timing oscillator and side-tone components. Orientation is such that the reed relay lies to the rear of the keyer when properly plugged in. The small power supply assembly is located below the logic board and contains rectifier and regulator components. The heat sink for the regulator pass transistor is at a positive DC potential and should not be allowed to touch the chassis or other components.

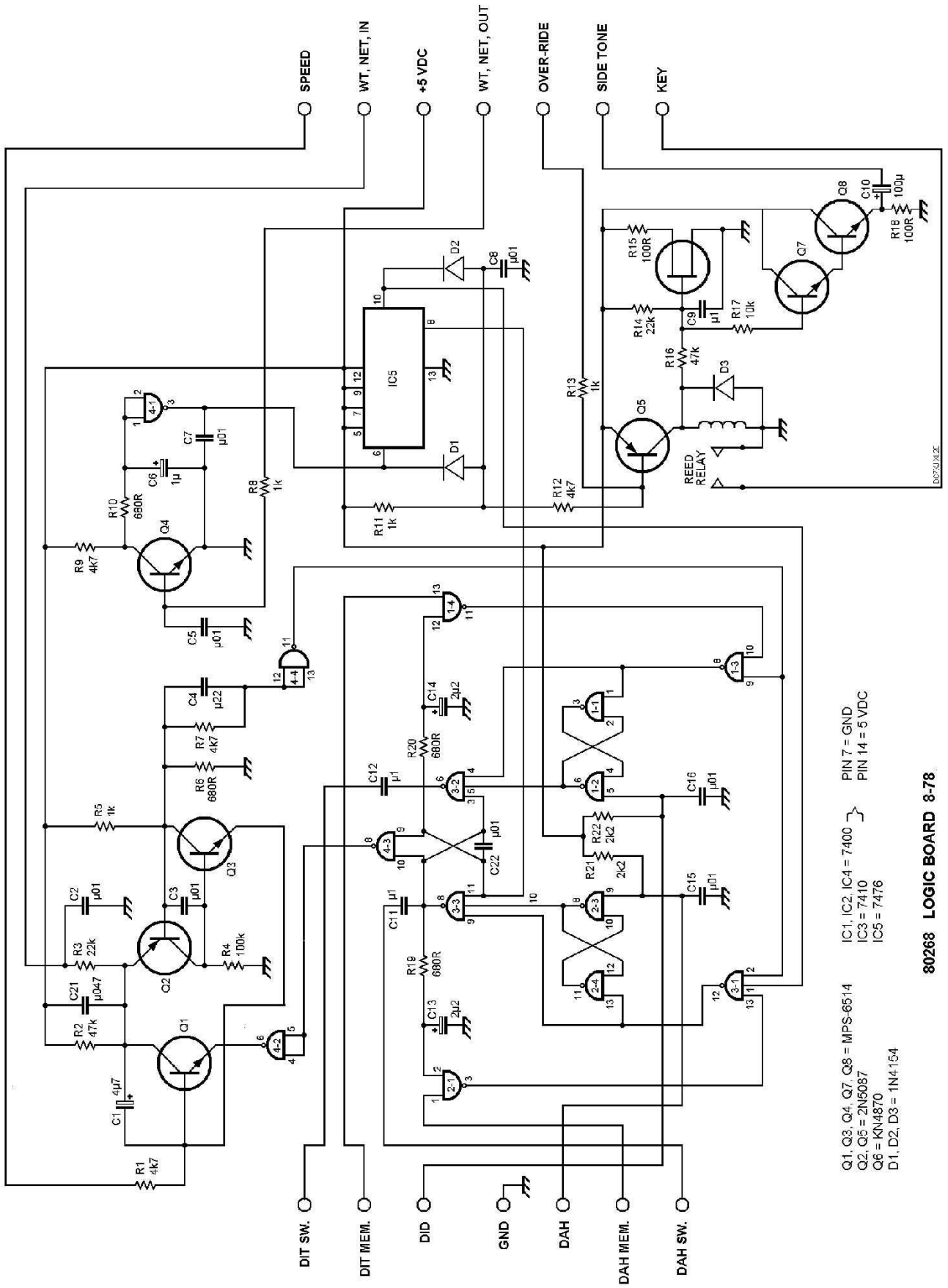

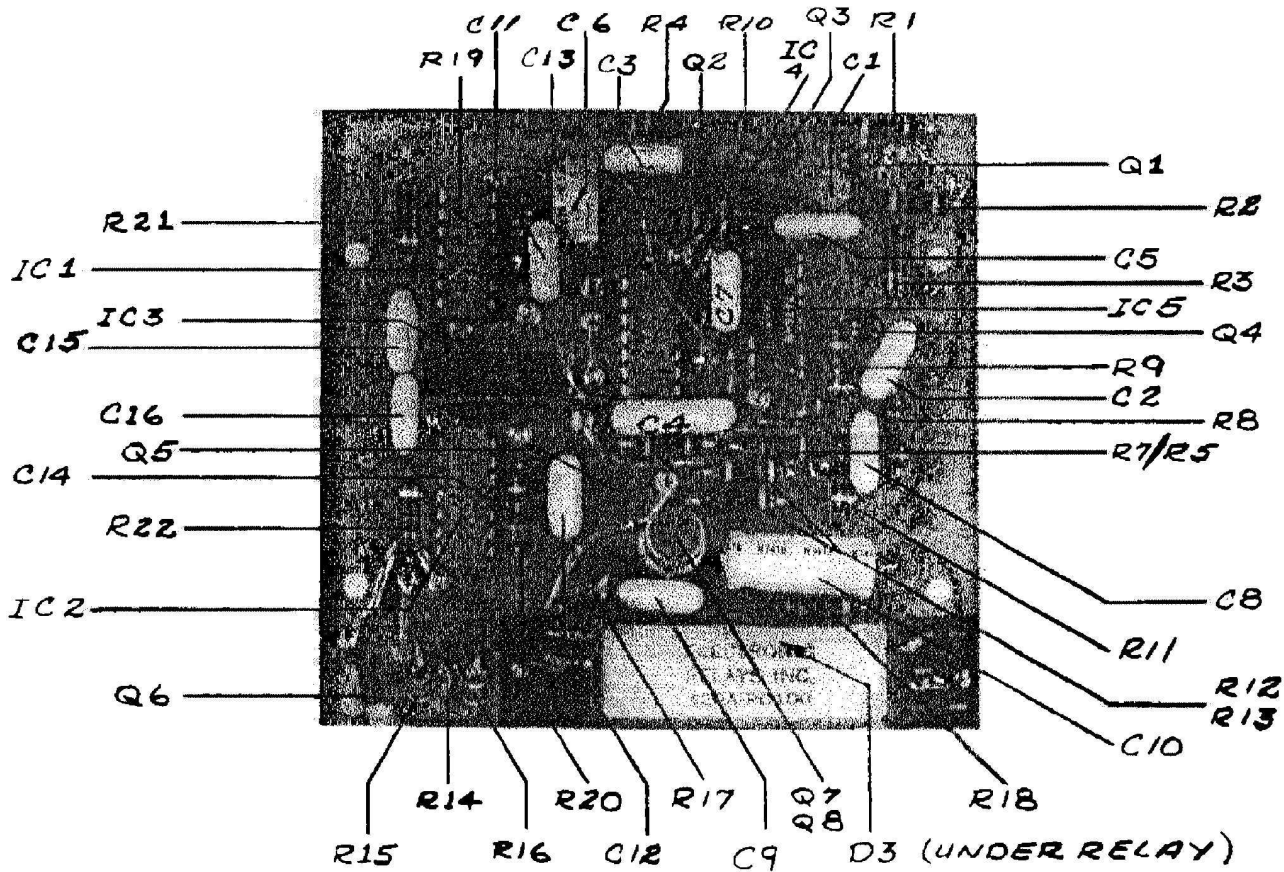
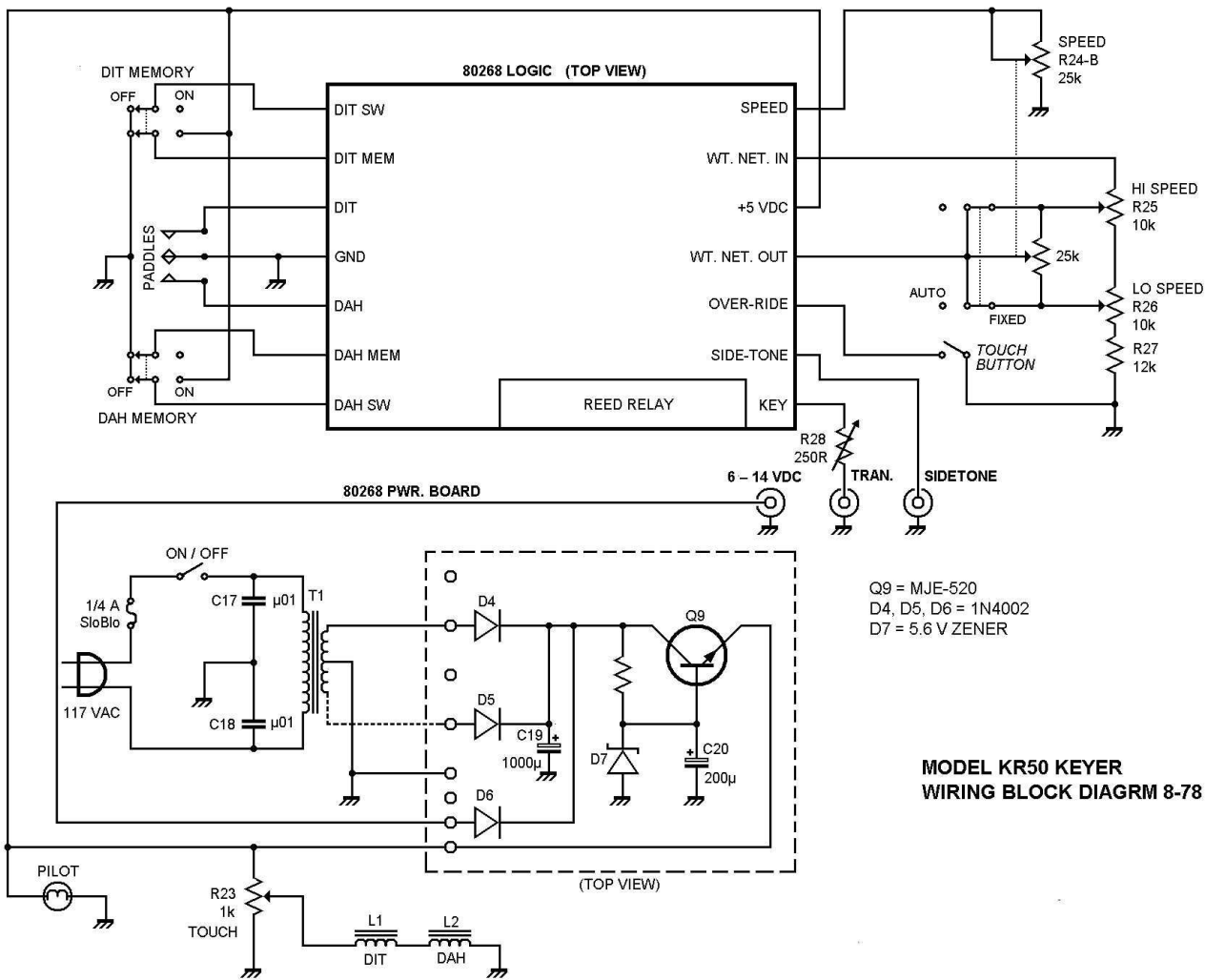

APPENDIX

METER METHOD OF DETERMINING WEIGHTING

Since weighting is the measure of the on-to-off ratio of the keyer relay, we can make use of the natural averaging characteristics of a d'Arsonval meter movement, such as is used in volt-ohm-milliammeters. To use this method, set the meter for OHMS mode and connect the leads to the TRANS jack on the keyer. Although we are using the ohmmeter, it is convenient in determining exact ratios that we use one of the linear scales. Most meters have a 1, 10 or 100 DC scale, and we should choose one of these. For our discussion, let us assume that we have a 0–10 scale. Also, let us assume that we have a zero ohms/right ohmmeter scale, i.e. when the ohmmeter prods are shorted, the meter deflects up scale to the 10 mark on the DC scale. (Some ohmmeter movements have a zero ohms/left scale. Weighting in these cases will be the opposite of that discussed here, i.e. if we determine that the weighting is heavy by 10 %, the zero ohms/left meter will mean that it is light by the same percentage).

To set the meter properly, depress the touch button and adjust the ZERO OHMS control on the meter so that it reads 10 on the scale. Now, if we send a string of classical dits, the "on" times will be exactly the same as the "off" times, and the meter should read 5 on the DC scale. (The average of zero and 10 is 5.) If the SPEED is slow, the meter may not fully filter out the pulses and the pointer may deflect in a range near center scale. The true average when this happens will be the center of the pulsing arc. For a classical string of dits at low speed, the meter may arc between 4 and 6, again resulting in an average reading of 5. Now, remember that this scale reading represents a 100 % weighting factor, so to convert the 5 reading into percent weighting, we have to multiply it by 20. This constant will now be used no matter what the scale reading.

A classical dah should be on three times as long as it is off, or in other words, it should show an average "on" time of 75 %. The meter should read 7.5 in this case. The dah is not used in determining the weighting percentage, so this step is only a check on the meter system.

Now, with dits running, if we set the LO SPEED control for a heavy weighting such that the meter reads 5.5, we have a 110 % weighting, ($5.5 \times 20 = 110$.) A 4.0 reading accomplished with the HI SPEED control indicates a light weighting of 80 %.

The variable weighting can also be set up using the meter, and the change as speed is varied noted.

Finally, please note that in the case of the zero ohms/left scale, only the percentage change from the classical value is determined. For example, the 5.5 meter reading would indicate 10 % light weighting --90 % and not 110 %. The 4.0 reading would indicate a 20 % heavy weighting --120 % and not 80 %. In either case, remember that a heavy weighting will have the meter read toward the zero ohms side of mid deflection and a light weighting toward the infinity side of mid deflection.

In setting weighting to your preference, you will most likely find that weighting 25–30 % either side of classical will be about as much as you will ever need, especially on the heavy side. Light weighting at high speeds up to 50 % or more are sometimes used.