

AT-1200

HF TUNNER

James Baxter Howell
127 Rockman Road
Grover, NC 28073

WG3H

Amp Supply Co.
Amp Supply Co.
Amp Supply Co.
Amp Supply Co.
Amp Supply Co.
Amp Supply Co.
Amp Supply Co.
Amp Supply Co.
Amp Supply Co.
Amp Supply Co.
Amp Supply Co.
Amp Supply Co.
Amp Supply Co.
Amp Supply Co.
Amp Supply Co.
Amp Supply Co.

Giving Amateurs their money's worth.

KM4TM
JAMES B. HOWELL SERVICES
ACCOUNTANT-LIC: #80-6022
229 DAN ST. TEL: 637-0313
SALSBURY, NC 28144

AT1200.MNL

AT-1200 SPECIFICATIONS

FREQUENCY COVERAGE: 1.8 TO 30 MHZ. BAND SWITCH MARKED FOR EACH AMATEUR BAND. HOWEVER, FREQUENCY COVERAGE BETWEEN AMATEUR BANDS IS SIMPLE.

INPUT IMPEDANCE: 50 OHMS - RESISTIVE

ANTENNA LOAD IMPEDANCE: JUST ABOUT ANY ANTENNA LOAD, COAX, SINGLE WIRE OR BALANCE LINE (WITH THE ACCESSORY BALUN BL-1200)

POWER CAPABILITY: 700 WATTS AVERAGE CONTINUOUS DUTY, 1200 WATTS PEP

METER: READS SWR

INSERTION LOSS: 0.5DB OR LESS ON EACH BAND AFTER TUNING

ANTENNA SELECTOR SWITCH: 3 COAX POSITION, 1 LONG WIRE OR 1 BALANCED LINE

DIMENSIONS: W 11" H 4.75" D 9.75"

WEIGHT: 9 LB.

FRONT PANEL CONTROLS ARE PROVIDED FOR THE ADJUSTMENT OF ANTENNA AND TRANSMITTER TUNING, SWR CALIBRATION, BANDSWITCHING AND SELECTION OF ANTENNA. THE REAR PANEL HAS FIVE TYPE SO-239 CONNECTORS, ONE FOR INPUT AND FOUR FOR OUTPUTS, A LONG WIRE POST, A GROUND POST, AND A 12 VOLT DC JACK FOR APPLYING POWER TO THE METER LAMP.

DESCRIPTION

THE AT-1200 ANTENNA TUNER IS DESIGNED AROUND THE VERSATILE 'T' TYPE MATCHING NETWORK. THIS TUNING NETWORK ALLOWS THE TRANSFER OF ALMOST ANY ANTENNA IMPEDANCE TO 50 OHMS. THE USE OF 3.5 KV CAPACITORS AND TAPPED COIL ALLOW A WIDE RANGE OF TUNING AND ANTENNA COMBINATIONS. THE SWITCHES USED IN THE AT 1200 ARE HIGH QUALITY CERAMIC SWITCHES FOR GUARANTEED PERFORMANCE.

THE 'T' NETWORK IS FED THROUGH AN ANTENNA SWITCH WHICH ALLOWS FRONT PANEL SELECTION OF FOUR DIFFERENT ANTENNAS. ANTENNA POSITION #1 CAN BE FED DIRECT, BYPASSING THE TUNER, OR CAN BE FED THROUGH THE TUNER. ANTENNA #4 CAN BE USED FOR EITHER FEEDING COAX OR A LONG WIRE.

FOR BALANCED FEEDLINE, THE BL-1200 CAN BE USED IN CONJUNCTION WITH THE AT-1200.

UNPACKING

CAREFULLY REMOVE THE AT-1200 FROM THE SHIPPING CARTON AND EXAMINE IT FOR EVIDENCE OF DAMAGE. IF ANY DAMAGE IS FOUND, IMMEDIATELY NOTIFY THE TRANSPORTATION COMPANY THAT DELIVERED THE SHIPMENT. KEEP THE SHIPPING CARTON AND PACKING MATERIAL FOR THE TRANSPORTATION COMPANY TO EXAMINE. KEEPING THESE ITEMS IS RECOMMENDED IN ANY CASE, AS HAVING THEM AVAILABLE MAKES SHIPMENT OF THE AT-1200 MUCH EASIER SHOULD IT EVER BE NECESSARY TO RETURN IT TO THE FACTORY FOR SERVICE.

FILL OUT THE WARRANTY REGISTRATION CARD AND RETURN IT NOW.

LOCATING

THE AT-1200 WILL WORK PROPERLY IN ALMOST ANY LOCATION. SELECT A LOCATION ON THE OPERATING TABLE THAT WILL ALLOW YOU TO REACH THE CONTROL KNOBS EASILY.

CONNECTING

CONNECT THE RF OUTPUT OF YOUR TRANSMITTER TO THE RF-IN CONNECTOR OF THE AT-1200, USING 50 OHM COAXIAL CABLE SUCH AS RG-8X OR RG-58/U. CABLE LENGTH IS NOT CRITICAL. CONNECT THE COAXIAL LINE FEEDING THE ANTENNA TO THE ANTENNA CONNECTOR 1, 2 OR 3 OF THE AT-1200. IF USING A LONG WIRE CONNECT IT TO THE LONG WIRE POST. IN INSTALLATIONS USING A TRANSCEIVER, OR TRANSMITTER-RECEIVER COMBINATIONS, THE AT-1200 SHOULD BE THE LAST ITEM THE OUT-GOING RF SIGNAL PASSES THROUGH BEFORE ENTERING THE FEED LINE TO THE ANTENNA.

BOND THE GROUND POST OF THE AT-1200 TO THE STATION GROUND WITH A SHORT PIECE OF HEAVY BRAID.

CONTROLS

THE CONTROLS OF THE AT-1200 INCLUDE THE BANDSWITCH, XMIT TUNING, ANTENNA TUNING, FWD/REF SWITCH FOR SWR, SET FOR THE SWR METER AND ANTENNA SELECTION. THE FUNCTIONS OF THESE CONTROLS ARE DESCRIBED BELOW.

BANDSWITCH

THE PRIMARY FUNCTION OF THE BANDSWITCH IS SELECTION OF THE TAPPED AND INDUCTOR NEEDED FOR EACH BAND. TWO 160 METER POSITIONS AND THREE 80/75 METER POSITIONS ARE PROVIDED BECAUSE OF THE LARGE RANGE OF REACTANCE VALUES THAT MUST BE ACCOMMODATED ON THESE BANDS. IF PROPER TUNING CANNOT BE ATTAINED IN THE SELECTED POSITION, THE BANDSWITCH MUST BE MOVED TO THE NEXT CLOCKWISE POSITION. (EVEN IF NOT IN THE SAME BAND). POSITION F & J ARE FOR ANTENNAS OR FREQUENCIES WHICH CANNOT BE TUNED ON NORMAL POSITIONS.

TUNING

THE ANTENNA OR OUTPUT TUNE CONTROL IS THE LEFT HAND TUNE CONTROLS. THE TRANSMITTER OR INPUT TUNING IS THE RIGHT HAND TUNE CONTROL. BOTH CONTROLS ADJUST THE AMOUNT OF CAPACITANCE TO VARY THE REACTANCE.

SWR METER CONTROLS

THE SET CONTROL IS USED TO ADJUST THE METER READING TO FULL SCALE (SET) WHEN THE REF/FWD SWITCH IS IN FWD POSITION. TO READ SWR, ADJUST THE SET CONTROL THEN PLACE THE REF/FWD SWITCH IN THE REF POSITION.

ANTENNA

THIS CONTROL SELECTS WHICH ANTENNA THE OUTPUT OF THE TUNER IS CONNECTED TO. BP POSITION WILL ALLOW YOU TO 'BYPASS' THE TUNER ON COAX POSITION #1 ONLY. THE SWR METER WILL STILL FUNCTION, BUT THE TUNE CONTROLS AND BANDSWITCH HAVE NO EFFECT. POSITION 1, 2, 3 AND BAL/LW ARE FED THROUGH THE TUNER.

OPERATING PROCEDURE

1. TUNE YOUR EXCITER ACCORDING TO THE OWNERS MANUAL, INTO A 50 OHM DUMMY LOAD.
2. SET THE AT-1200 BANDSWITCH TO THE DESIRED BAND. (USE THE MOST CCW POSITION FOR 80 ON 160 WHEN STARTING).
3. SET BOTH TUNE CONTROLS TO '5' .
4. SET THE REF/FWD POSITION TO REF AND TURN SET CONTROL FULL CLOCKWISE.
5. INSERT JUST ENOUGH POWER TO GET A READING ON THE SWR METER. ADJUST THE TUNE CONTROLS FOR A MINIMUM READING ON THE SWR METER.
6. INCREASE POWER AND REPEAT STEP 5. CONTINUE UNTIL YOU ARE AT FULL POWER. (DO NOT EXCEED 1200 WATTS PEP). IF A LOW SWR READING CANNOT BE OBTAINED, ROTATE THE INDUCTANCE SWITCH ONE POSITION CLOCKWISE (HIGHER INDUCTANCE). DO NOT USE MORE INDUCTANCE THAN NECESSARY.
7. A FINAL READING FOR SWR CAN BE OBTAINED BY PLACING THE REF/FWD SWITCH IN FWD POSITION. ROTATE SET CONTROL FOR A 'SET' READING ON THE METER. PLACE THE SWITCH IN REF POSITION FOR AN SWR READING.

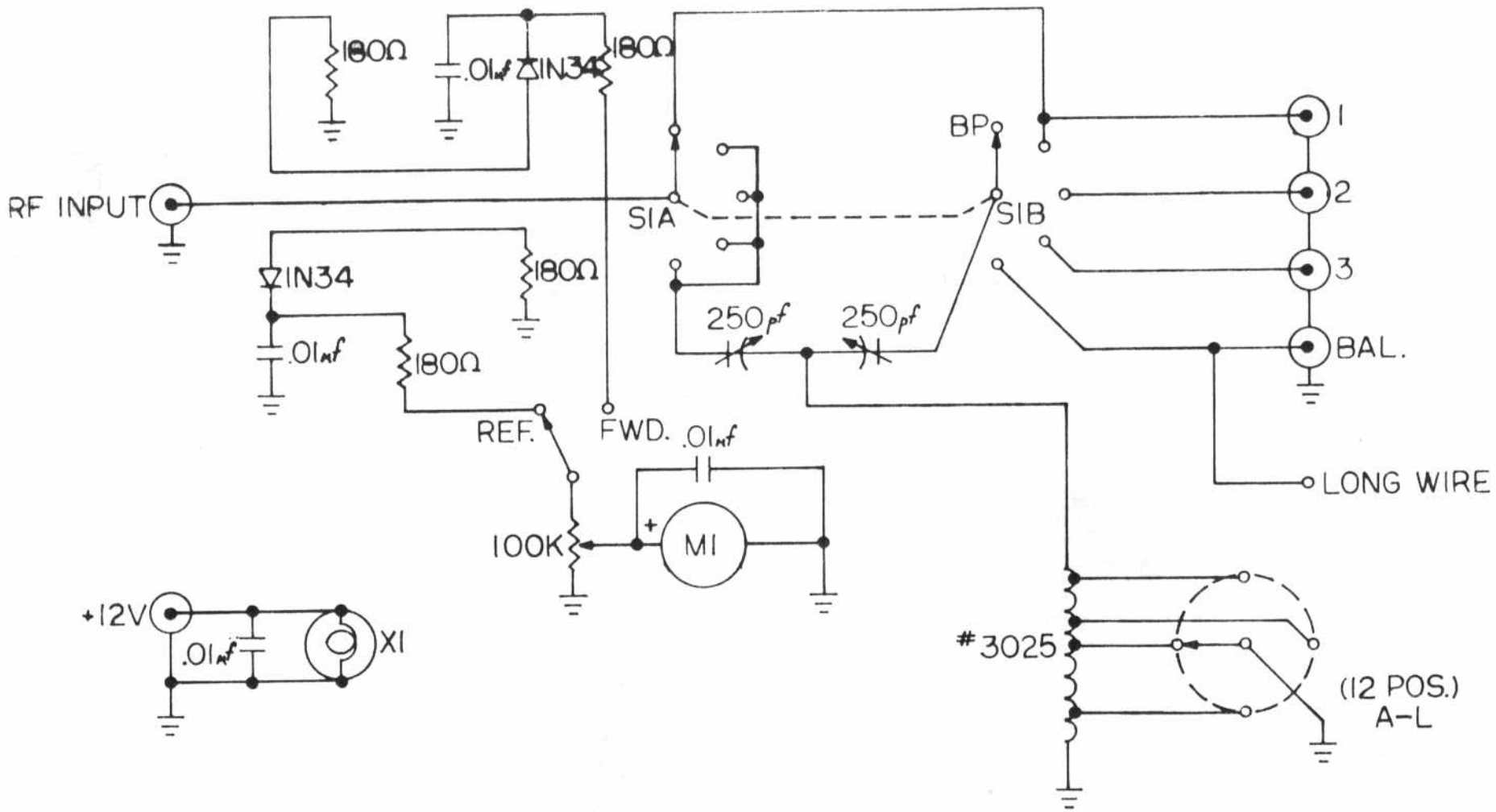

AMP SUPPLY CO.

AT-1200 SCHEMATIC

CHD
APP.WBJI

5/18/83

AT-12001