

# OPERATING MANUAL

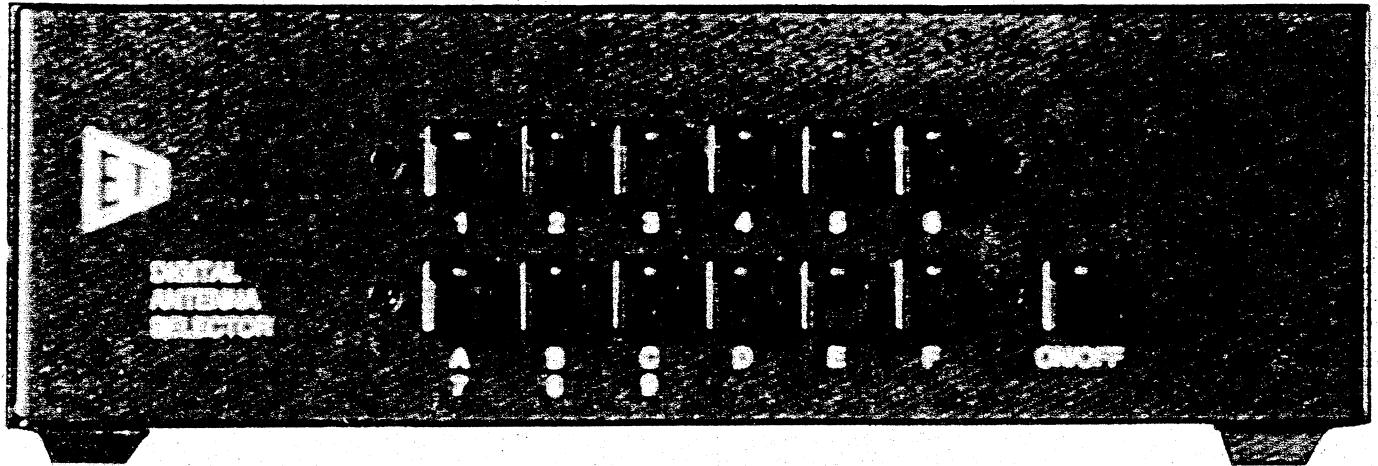

## *DAS*

### DIGITAL ANTENNA SELECTOR

**ALPHA  
POWER**

***ALPHA/POWER***

*by CrossLink, Inc. RF Power for Communications and Industry*

6185 Arapahoe Avenue, Boulder, Colorado 80303-1401

(303) 473-9232 \* FAX (303) 473-9660



# Table of Contents

<b>1.0 INTRODUCTION</b> .....	<b>1</b>
<b>2.0 OVERVIEW OF THE ETO DIGITAL ANTENNA SELECTOR</b> .....	<b>2</b>
<b>3.0 ANTENNA SYSTEM CONFIGURATIONS USABLE WITH DAS</b> .....	<b>2</b>
Figure 3.1 Simplified Diagram, "One-of-Nine" System.....	3
Figure 3.2 Two-Tier "1 of 36" RF Switching system.....	3
Figure 3.3 "1-of-36" Cabling System.....	4
<b>4.0 CONTROL, INDICATOR, AND SYSTEM CONNECTION FUNCTIONS</b> .....	<b>5</b>
<b>5.0 OPERATION USING THE DAS</b> .....	<b>7</b>
TABLE 1 .....	8
TABLE 2 .....	9
<b>6.0 TROUBLESHOOTING SUGGESTIONS</b> .....	<b>10</b>
<b>APPENDIX A</b> .....	<b>11</b>



# 1.0 INTRODUCTION

This manual provides information necessary to install and operate the ETO DAS-1 Digital Antenna Selector. Schematic diagrams are available on request, at no charge to the owner. For your own protection, please return the owner registration card immediately and advise ETO promptly of any future address change.

## 1.1 FCC Information

This equipment generates and uses radio frequency energy and, if not installed and used properly, (i.e., in strict accordance with manufacturer's instructions), may cause interference to radio and television reception. It has been tested and found to comply with the limits for a Class B computing device in accordance with the specifications in Subpart J of Part 15 of FCC rules, which are designed to provide reasonable protection against such interference in a residential installation.

However, there is no absolute guarantee that interference will not occur in a particular installation. If this equipment does cause interference to radio or television reception, which can be determined by turning the equipment off and on, the user is encouraged to try to correct the interference by one or more of the following measures:

- \* De-couple cables with ferrite
- \* Adjust the receiving antenna
- \* Move the DAS away from the radio or TV receiver
- \* Plug the DAS into a different outlet so that the DAS and receiver are on different branch circuits

If necessary, the user should consult CrossLink Customer Service for additional suggestions. The user may find the booklet, *How to Identify and Resolve Radio/TV Interference Problems*, prepared by the Federal Communications Commission helpful. The booklet is available from the U.S. Government Printing Office, Washington, DC 20402, Stock Number 004-000-00345-4.

## 1.2 Owner Assistance

Assistance is available from CrossLink Customer Service (Communications Products): telephone (303) 473-9232, FAX (303) 473-9660, or by mail.

## 2.0 OVERVIEW OF THE ETO DIGITAL ANTENNA SELECTOR

The Digital Antenna Selector (DAS) provides instantaneous selection of any antenna in systems as large as 36 antennas by providing coil power to appropriate RF relay boxes. The relays, located in the station and/or remotely on antenna towers, etc., switch feed lines as necessary to connect the selected antenna.

Automatic antenna selection when changing bands is available when the DAS is used with ETO's *ALPHA 87A* microprocessor-controlled amplifier; user-programmable antenna selection memory is incorporated in the *87A*. When the amplifier changes bands it sends to the DAS via an RS-232 link digital signals identifying the antenna most recently programmed for that particular band. In such systems the DAS also may be controlled by computer and/or manually.

The DAS also may be used as a "stand-alone" selector to provide instant control of small or large antenna systems. When it is used without an *ALPHA 87A* amplifier, antennas may be selected manually via the DAS' front-panel push buttons and/or by computer (locally or remotely).

### PROGRAMMING ANTENNA SELECTIONS

The *ALPHA 87A* antenna memory may be programmed on any given band simply by pushing two buttons on the *87A* panel. It also may be programmed with simple ASCII commands sent via an RS-232 link from a local or remote computer or terminal. The antenna in use may be changed instantly by simply overwriting the existing selection in either of the same ways.

When more than one antenna is available for a given band, the operator often wishes to change antennas *temporarily, without changing the selection program*. This may be accomplished simply by selecting the new antenna *using the push-buttons on the DAS panel*. Antenna choices made from the DAS panel are *not* stored in *87A* memory, and at subsequent band changes the DAS resumes automatic antenna switching according to the selections previously stored in memory.

## 3.0 ANTENNA SYSTEM CONFIGURATIONS USABLE WITH DAS

The DAS is capable of operating in either "one-of-nine" or "one-of-36" basic system configurations.

In the one-of-nine mode the DAS provides coil power to operate a single RF relay box or set of relays having up to 9 outputs, each of which feeds an individual antenna. The DAS may be controlled by an *ALPHA 87A*, a computer, and/or manually.

The one-of-thirty-six mode allows automatic and instant control of very large antenna systems, typically employing shared feed lines to remote towers or distribution points. Commonly, a five- or six-way relay box located in the station switches feed lines to as many as six remote boxes, each of which may have up to six output ports. The DAS is capable of powering all relays in such a system.

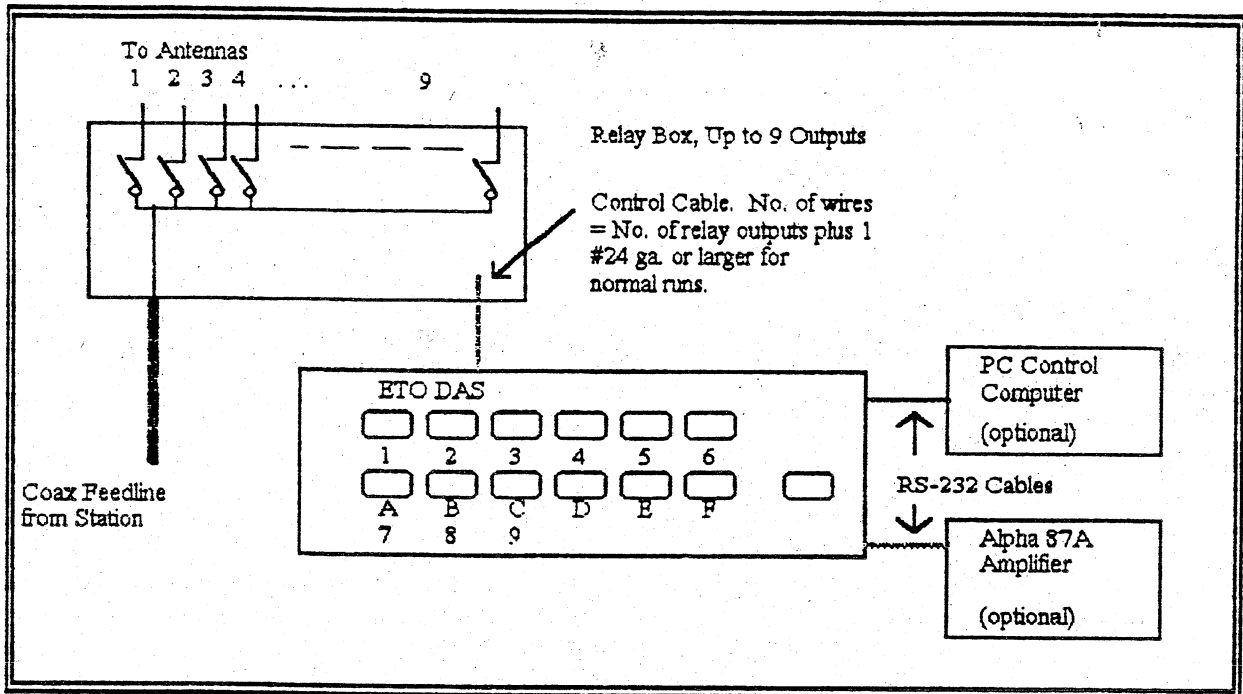

**FIGURE 3.1**  
**SIMPLIFIED DIAGRAM, "ONE-OF-NINE" SYSTEM**

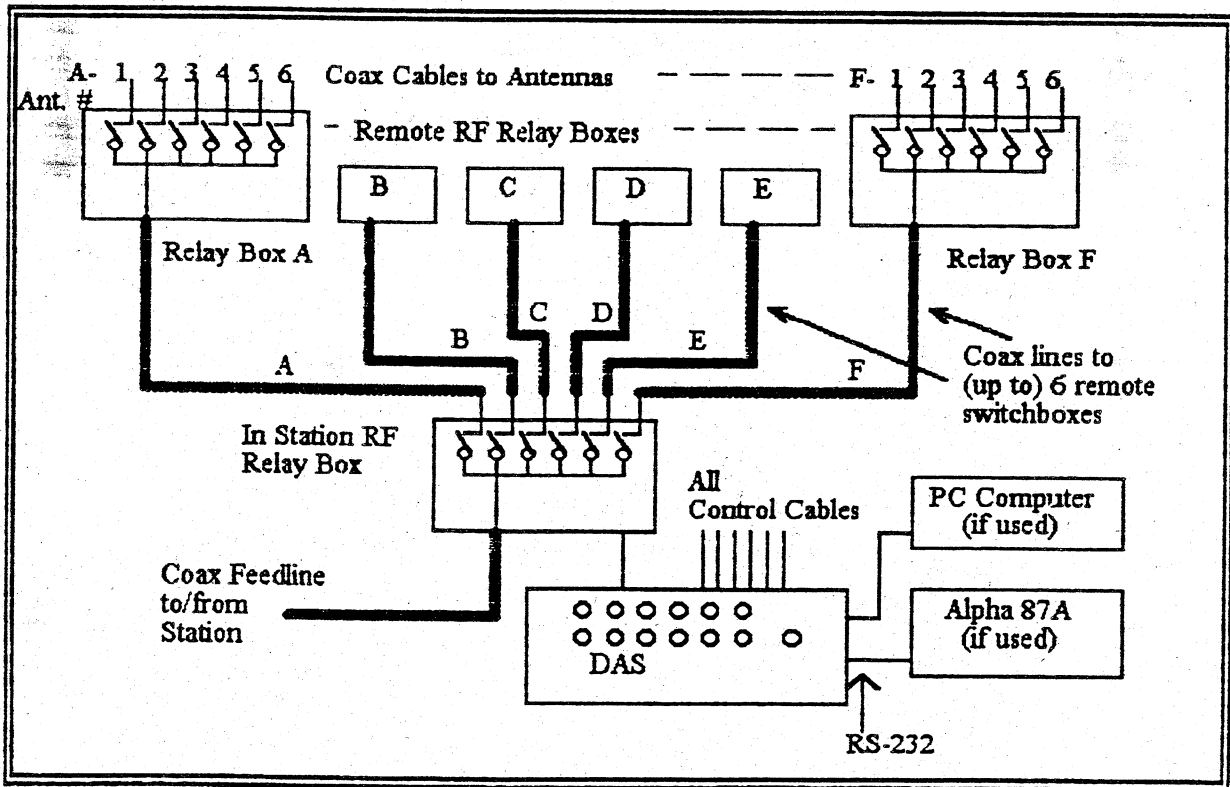

**FIGURE 3.2**  
**TWO-TIER "1 OF 36" RF SWITCHING SYSTEM**

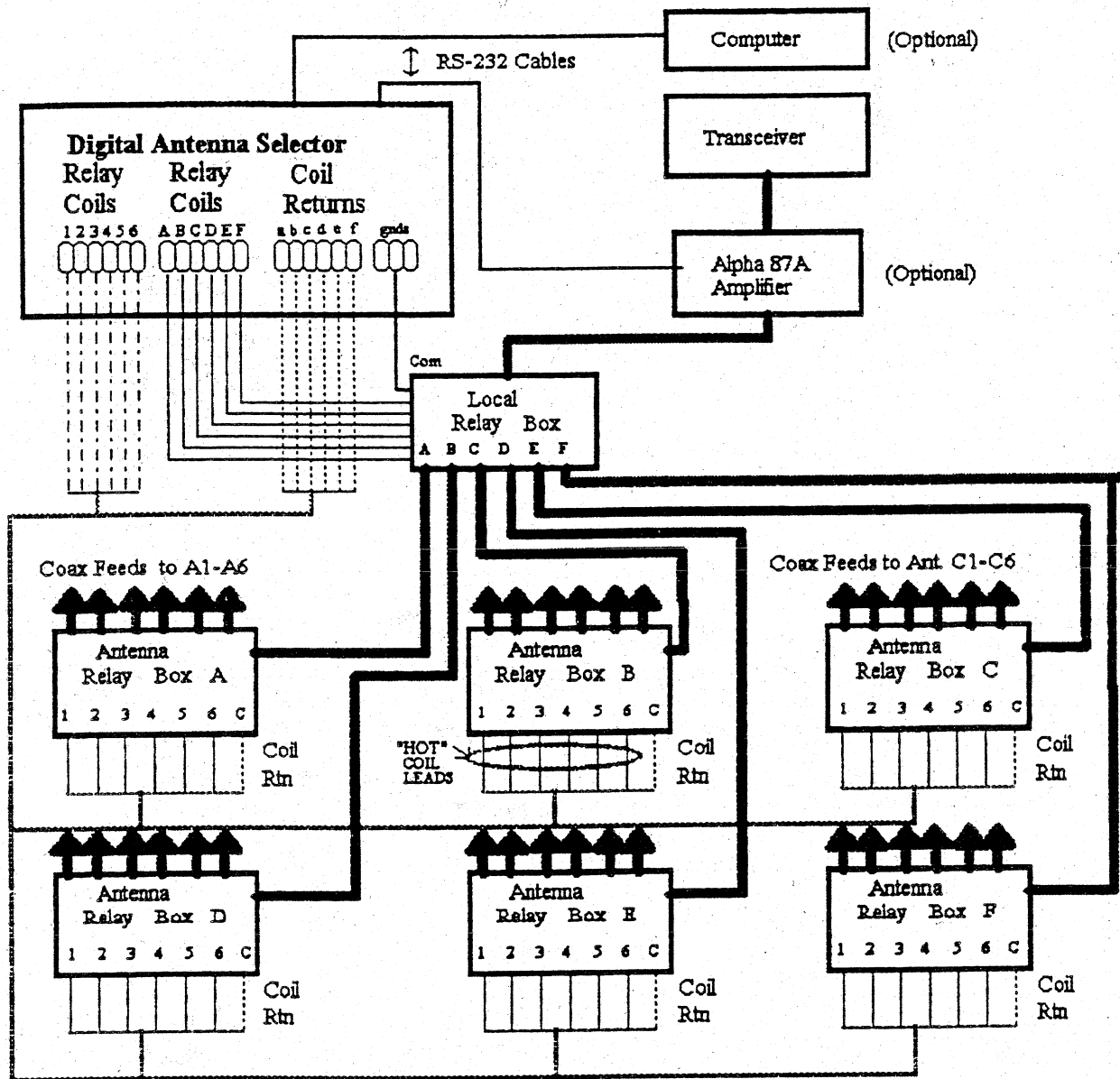

- Relay Coil "HOT" feeds paralleled to all remote boxes
- Common Coil Return Wire, one from each box A-F
- \_\_\_\_\_ Control - Single Wire
- Control - Seven Wire Cables #24ga. wire
- ===== RF Cable

**FIGURE 3.3**  
**"1-OF-36" CABLING SYSTEM**



## 4.0 CONTROL, INDICATOR, AND SYSTEM CONNECTION FUNCTIONS

### 4.1 Push-button Switches (with LED indicators)

A power switch and 12 selector switches (two rows of six buttons each) used to select antennas are located on the front panel of the DAS. When a button is pushed its LED will light to indicate that the input has been accepted by the microprocessor.

In the so-called "one-of-nine" mode, the top six buttons (labeled 1-6) may be used to manually select the corresponding outputs of a single relay box (e.g., 4-, 5- or 6-way boxes offered by DX Engineering and others). Buttons A-F are not used in this arrangement.

Alternatively in the one-of-nine mode, buttons 1-6 plus buttons 7-9 in the lower row (which also are labeled A-C) may be used to select manually the outputs of a single nine-way relay bank.

In the "one-of-36" mode, pressing one button A-F from the lower row selects the corresponding remote relay box and a second button 1-6 from the upper row selects the desired output port of that particular box.

The two buttons may be pushed simultaneously. If two buttons in the same row are pushed, either the input will be ignored or the button which is connected first is selected. The LED indicators always identify the output connected. If the selection is incorrect, repeat the procedure.

### 4.2 RS-232 Ports and Control Cables (*IMPORTANT!*)

The DAS may be controlled remotely over an RS-232 link. A male and a female connector are provided to allow connecting the DAS to both an *ALPHA 87A* and a computer. Either cable may be plugged into either of the DB25B sub-miniature connectors on the rear of the DAS. Pins 1, 2, 3, 7 must be connected as a minimum for the link to work. Pins 4,5 are used for handshaking purposes by the *ALPHA 87A* or other equipment which may be connected.

The DAS monitors the RS-232 signal to receive the desired command strings and feeds it on to the second DB25B connector without modification. Twelve lines pass through from one connector to the other. These pins are 1, 2, 3, 4, 5, 7, 9, 12, 13, 14, 19, 22. Pins 1, 2, 3, 4, 5, 7 are the primary connections used for RS-232 communications. The others set the baud rate of the DAS and the *ALPHA 87A*.

*Pins 9, 12, 13, 14, 22 should not be wired to the computer connector since they might conflict with the voltages on those pins at the computer. The cable shipped with the DAS should be used between the DAS and the ALPHA 87A. If the ALPHA is to be controlled by a computer, a special cable with only pins 1, 2, 3, 4, 5, 7 connected must be used between the DAS and the computer. The baud rate of the communication link can be controlled as outlined in section 5.2.*

### 4.3 Option Select Switch S1

S1 is an 8 pole DIP switch located near the center of the main DAS circuit board. This switch controls two functions of the DAS: (1) sections S1-1 and S1-2 determine whether the incoming RS-232 signal is received on pin 2 or pin 3 of the DB25B connector and (2) S1-3 controls the mode of operation of the DAS, either 1-of-9 antennas or 1-of-36. The other switches are not used at this time but must be in the ON position for proper DAS operation.

#### 4.4 T/R line "hot-switch" interlock

Two RCA jacks on the rear panel labeled T/R LINE provide a path through the DAS for the normal T/R or key signal. Patching the T/R line (from transceiver to amplifier) through these jacks prevents switching antenna relays while transmitting. When the voltage is near zero, the DAS locks out antenna relay changes.

As soon as T/R line voltage returns to a non-zero level the DAS will again allow antenna changes and immediately execute the last change called for. The only exception is a DAS power off command. If an ANTENNA OFF command is issued or the ON/OFF switch is pushed, the DAS will power down and take all relays off line. The DAS will not power back on or change relays until the T/R line returns to a non-zero voltage (receive).

Use of the T/R interlock feature is not required but is highly recommended because it can prevent accidental "hot-switching" damage to the antenna switching relays. The T/R line is monitored by a high impedance circuit so characteristics of the T/R signal are not changed. This protective interlock will work on T/R lines with open-circuit DC voltages from -70 to +70. If this feature is not to be used, simply don't connect the T/R line to the jacks.

#### 4.5 Selection of Relay Driving Voltage

By making a simple adjustment, the user may set the DAS to provide either nominal 12-14 VDC or 24-28 VDC to power the coils of RF relays used with it. A three-pin jumper strip for this purpose is located between the front of the DAS circuit board and the voltage regulator which is equipped with a heat sink.

To provide nominal 12 VDC coil voltage, install the movable two-pin jumper across the right-most (as viewed from the front) and center pins of the strip. For 24 VDC, place the jumper across the left-most and center pins.

## 5.0 OPERATION USING THE DAS

### 5.1 Operation with the ETO *ALPHA 87A* Amplifier

The DAS is designed to complement the automatic band change capability of the *ALPHA 87A* amplifier. The *ALPHA 87A* must be equipped with EPROM ETO P/N UPX-X108-G or newer to work with the DAS. All current production *ALPHA 87As* are delivered with a suitable EPROM installed. When a DAS is sold for use with early model *87As*, a replacement EPROM is shipped with the DAS at no extra charge. For information on installing this EPROM see APPENDIX A.

To control the DAS with an *ALPHA 87A*, DAS internal DIP switch section S1-1 must be ON and S1-2 must be OFF. (NOTE: When an *ALPHA 87A* is connected, the DAS also will respond to computer commands with S1-1 and S1-2 set as above. It is actually reading and responding to the *ALPHA's* response to the computer commands. For computer control when no *ALPHA 87A* is connected, however, the DIP switches must be set as described in section 5.2)

The *ALPHA 87A* is connected to the DAS by an RS-232 cable from jack J1 on the *ALPHA 87A* to the appropriate RS-232 connector on the Digital Antenna Selector. Since the RS-232 passes through the selector for monitoring purposes only, either connector may be used. The other connector may be used to "daisy chain" the RS-232 line on to a computer if so desired. The DAS does not change the characteristics of operation of the *ALPHA 87A* used with a computer.

With the DAS properly connected, the *ALPHA 87A* sends the message ANTENNA = xx each time the amplifier band is changed. The DAS reads this message and sets the associated antenna relay(s) accordingly.

The *ALPHA 87A* amplifier stores the last antenna selection used on each band. Upon returning to a given band, the last antenna used there is automatically selected while the *ALPHA* is changing bands and tuning up.

To program the *ALPHA 87A* to work with the DAS, it is only necessary to select an antenna by using the front panel BAND, MHz buttons — item 5.3 in the *87A* operating manual. For this purpose the BAND BUTTONS are numbered 1 to 9 from left to right. (The 1.8 MHz button is also #1 and A, 3.5 MHz is #2 and B, etc. To avoid clutter, these extra numerals and letters are *not* actually screened on the *87A* panel.) For one-of-36 operation, buttons 1-6 also serve as A-F.

#### 5.1.1 Programming in the one-of-nine antenna selection mode:

- 1) Make sure the *ALPHA* is on the band for which you wish to program an antenna selection, and that it is not transmitting.
- 2) Push the *87A* ENTER button. The ENTER LED will begin flashing, indicating that the system is ready for antenna selection.
- 3) Before the LED stops flashing (approximately 3 seconds) push the *ALPHA 87A's* BAND button corresponding to the number (1-9) of the antenna desired. If selection is not completed before the LED stops flashing, the programming will not be successful and must be repeated from the beginning. When programming is completed successfully, the selected antenna is connected immediately and confirmed by LED indicators on the DAS panel. Whenever the *ALPHA 87A* switches to that band,

the same antenna will automatically be selected. To change the antenna programmed for a given band, simply overwrite memory by repeating the above process.

### 5.1.2 Programming in the one-of-36 antenna selection mode

- 1) Switch the *ALPHA* to the band for which you wish to program the antenna selection, and make sure it is not transmitting.
- 2) Push the *87A* ENTER button. The ENTER LED will begin flashing, indicating that the system is ready for antenna selection.
- 3) Before the LED stops flashing (approximately 3 seconds)...
  - a) First push the *87A* BAND button corresponding to the *alphabetic* designation (A-F) of the desired antenna, then...
  - b) Push the *87A* BAND button (1-6) corresponding to the *numerical* designation of the desired antenna.

As soon as the second character is entered successfully, the LED indicator will stop flashing, and the selected antenna will be connected as confirmed by LEDs on the DAS panel. If the LED stops flashing before both characters are entered, programming will be unsuccessful and the process must be restarted from the beginning.

When the DAS is connected by an RS-232 cable to an *ALPHA 87A*, DAS power will automatically switch ON and OFF with the *ALPHA*. If it is desired to operate the DAS independent of the *ALPHA 87A*, the DAS ON/OFF switch may be used to toggle power on/off.

**NOTE:** Although the DAS appears to be inoperative when "off", the internal power remains on and the DAS is in an idle state waiting for a turn-on signal. As long as the DAS is plugged into the power mains, possibly lethal voltage exists inside the unit. **WARNING!** FOR YOUR OWN SAFETY, ALWAYS UNPLUG THE DAS BEFORE REMOVING ITS COVER!

### 5.2 Controlling the DAS from a computer or terminal

The DAS may be controlled locally or remotely via the RS-232 link from a terminal or computer with communications software.

Switch S1 on the DAS circuit board controls whether the DAS is listening to the computer TX line or the *ALPHA* TX line. To control the DAS with a computer only (DTE device) switch S1-1 must be OFF and S1-2 must be ON (see Table 1).

**TABLE 1**

<u>TYPE OF CONTROL DEVICE</u>	<u>S1-1</u>	<u>S1-2</u>
DCE ( <i>ALPHA 87A</i> OR terminal)	ON	OFF
DTE (Computer)	OFF	ON

Connection from computer to DAS is made with an RS-232 cable. *Pins 9, 12, 13, 14, 22 must not be connected to the computer.* These pins are reserved to set the baud rate of the DAS, which must be the same as it is in the *ALPHA 87A*. Any cable constructed to operate between the computer and an *ALPHA 87A* will also function with the DAS.

For baud rate setting, see table 2. "Low" means the pin is connected to pin 7 of the cable. "Open" means no connection is made. The simplest approach is to leave these pins open for a baud rate of 4800. Pins 13, 14 are always left open.

**TABLE 2**

<u>BAUD RATE</u>	<u>PIN 12</u>	<u>PIN 22</u>	<u>PIN 9</u>
default 4800	open	open	open
9600	low	low	low
4800	low	low	open
2400	low	open	low
1200	low	open	open
600	open	low	low
300	open	low	open
150	open	open	low

Control of the DAS is very simple. The internal microprocessor monitors the RS-232 signal looking for a string of characters with the proper format. Only one key word "ANTENNA" is accepted. It must be followed by at least one space or equal sign but any number of spaces or equal signs may be included. Then the new setting is sent followed by a carriage return.

For example, to select antenna D6 the command would be "ANTENNA D6" or "ANTENNA = D6". The words 'ON' and 'OFF' will turn the DAS on and off, i.e. "ANTENNA = OFF" will turn the DAS off and "ANTENNA ON" will turn the DAS on.

Antenna selections received from a computer are stored in the memory of an associated *ALPHA 87A*, as are selections made from the *87A* front panel.

### 5.3 Controlling the DAS manually

Any antenna may be selected directly from the DAS front panel.

In the one-of-nine mode, for example, to switch in antenna #5 from the DAS, merely press button #5.

In the one-of-36 mode, to switch in antenna #C3 just press buttons C and 3. When each button is pressed its LED will light, confirming the antenna selected.

NOTE: Antenna selections made from the DAS are not entered into *ALPHA 87A* memory and will not be "remembered" when the *87A* is next switched again to the same band. Only selections made from the *87A* or from a computer or terminal connected through the DAS to an *87A* are entered into memory.

## 6.0 TROUBLESHOOTING SUGGESTIONS

6.1 Selector has no power, appears dead; no response when pressing push-button switches

- 1) Check the fuse at the rear of the circuit board. Make sure that the line cord is disconnected before touching any terminals in this corner of the circuit board.
- 2) Check that the T/R line is not shorted to ground. If the T/R line is grounded the DAS will not turn on or change relay settings.

6.2 Selector operates normally but antenna relays don't close

Check wiring from DAS to the antenna relays. There must be a wire from the terminal strip to the relay and back from the relay to ground or one of the return terminals. Check for voltage at the appropriate terminal strip locations.

Example: for A1 selected, coil voltage should exist between terminals 1 and A. There will be a ground at terminal A RETURN.

6.3 *ALPHA 87A* does not control antenna selections

- 1) Make sure switch S1 is set properly for *ALPHA 87A* control.
- 2) If the *ALPHA 87A* is being operated at a baud rate other than 4800, the *ALPHA* and DAS RS-232 connectors must be wired for the same baud rate.

6.4 Computer commands do not change antenna selection

- 1) Make sure that switch S1 is set for computer operation.
- 2) Make sure that the computer is set to the baud rate of the DAS as determined in paragraph 2.3.
- 3) Make sure the message sent by the computer has the correct syntax, e.g., "ANTENNA = A1"

6.5 DAS buttons D, E, F don't do anything.

Check switch S1. If DAS is in 1-of-9 mode, these buttons are not used.

## 7.0 APPENDIX A

### How to Change the EPROM on the *ALPHA 87A* Control Board.

Disconnect the *ALPHA* power cord at the source.

Wait at least one minute for the high voltage to bleed down to a safe level.

Remove the top cover of the *ALPHA 87A* by removing all screws except the two in the center of the tube vents.

Slide the front of the amplifier not more than two inches over the edge of the table. (DO NOT LIFT the *ALPHA* with the transformer in place!) Remove the four flat head screws securing the front panel at the sides and the five screws at the bottom.

Carefully pull the front panel forward. Pull it very slowly and note the position of each cable connection before gently disconnecting each one. Remove the panel from the bottom to reveal the socketed 28 pin IC (U7) on the microprocessor control board.

**CAUTION!** Before touching the board or any of its components make sure that your body is grounded by touching one hand firmly to the chassis. This will discharge any static buildup and prevent damage to the integrated circuits.

Use a VERY small screwdriver to pry VERY gently and alternately on the two ends of EPROM IC (U7) until it lifts free from the socket.

Replace the old EPROM with the new on from the DAS conversion kit. Make sure all EPROM pins are straight and note that pin 1 of the IC must be in the upper left corner of the socket, notch up (see diagram at right).

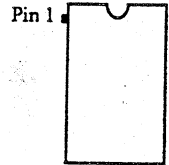

Reverse the disassembly process to close up the *ALPHA 87A*. Be especially careful to make sure that all the front panel cables are plugged in firmly and dressed exactly as before.





# ALPHA PRODUCTS WARRANTY

**CROSSLINK, INC. WARRANTS AS FOLLOWS EACH NEW AMATEUR RADIO PRODUCT OF ITS MANUFACTURE, SOLD AND USED IN THE UNITED STATES, ITS POSSESSIONS, AND CANADA:**

- (1) Workmanship and all components except rf power tubes are warranted for FOUR YEARS from date of original purchase if used exclusively in licensed amateur radio service. **WARRANTY IS VOIDED BY ILLEGAL SALE OR USE OF EQUIPMENT** (e.g. U.S. sale of export models).
- (2) *Eimac* power tubes are warranted by their manufacturer; API will assist owners in securing warranty service if requested.  
  
*Svetlana* power tubes are warranted by API for one year from date of original purchase.
- (3) Warranty does not apply to repair of damage resulting from improper maintenance or repair, misuse, neglect, abuse, or improper installation, nor to units not operated in accordance with specifications and instructions furnished by API, nor to units repaired or altered by persons not authorized by API, nor in cases where the serial number has been removed, altered, or defaced.
- (4) If a malfunction is suspected, before attempting repairs or returning equipment to API or the selling dealer for service, the owner shall contact API or the selling dealer factory service department, providing model and serial number plus details of equipment hookup, accessory equipment used, operating conditions, and abnormalities observed. API will furnish a new part in exchange for any covered defective part or, if it is determined that factory service is required, will authorize return to factory. Equipment authorized for return shall be shipped to API fully prepaid and insured via United Parcel or air express, **USING ONLY FACTORY APPROVED PACKING; REMOVE POWER TRANSFORMER BEFORE SHIPPING ANY UNIT WHICH WAS ORIGINALLY SHIPPED FROM THE FACTORY WITH TRANSFORMER REMOVED!** All shipping charges are the responsibility of the owner.
- (5) In order to receive service under this warranty, the owner must either (a) have returned a completed warranty registration form to API within 30 days of original purchase OR (b) provide proof of ownership as well as proof of the original date of sale by API or by an authorized API dealer.
- (6) No person is authorized to assume for API any liability in connection with our products, other than as set forth in this warranty. API reserves the right to change its products as it deems desirable, without obligating itself to make such changes available for previously manufactured products.

**UNDER PROVISIONS OF THE FEDERAL MAGNUSON-MOSS WARRANTY ACT, THIS WARRANTY POLICY IS CLASSIFIED AS A LIMITED WARRANTY.**

Rev. 08/16/01

**ALPHA** CrossLink, Inc.  
**POWER**

6185 Arapahoe Avenue, Boulder, Colorado 80303-1401 • (303) 473-9232 • FAX (303) 473-9660

*RF Power for Communications and Industry*

