

V-107
6 and 2 METER
VFO



SPECIFICATIONS

FREQUENCY COVERAGE	8.333 to 8.666 mc for 6 meters 8.0 to 8.222 mc for 2 meters
FREQUENCY STABILITY	± 500 cycles per hour after 30 minute warm up.
RF OUTPUT	20 volts RMS minimum into 47K shunted by 30 pf.
POWER REQUIREMENTS	200 volts DC, 30 ma. 12.6 volts, 0.15 amp.
TUBE COMPLEMENT	12DK6 Oscillator OA2 Voltage Regulator
SIZE	5½" x 4-5/16" x 6½"

This VFO is designed for the ever-growing group of Hams who are active on the VHF bands. Coverage is for the most active part of 6 meters (50 to 52 mc) or for the entire 2 meter band (144 to 148 mc). The VFO can be calibrated for either band; a two scale dial is easily calibrated for either band.

The Clapp Oscillator circuit assures maximum stability, and the high value of shunting capacitors C-6 and C-7 minimizes any change in tube or circuit capacity. A voltage regulator further improves stability by providing pure, variation-free DC voltage to the screen of the oscillator tube.

CONSTRUCTION HINTS

Since the output of this is in 8 mc range, and it is important that the output frequency remain as stable as possible, here are a few pointers:

1. Keep all leads as short as possible — snug up the leads of each component.
2. Keep bare wire leads snug; they add mechanical stability.
3. Be sure mechanical parts are mounted firmly.

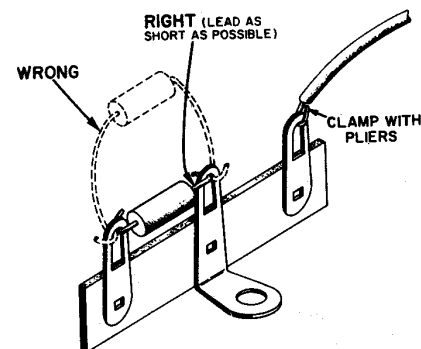

As you wire, make good mechanical connections before you solder. And, last, but not least, check your soldering. The completed solder connection should have a shiny, metallic finish. If it is not shiny, reheat it and add a little solder.

UNPACKING

- Carefully unpack all parts and check them against the PARTS LIST.
- Assort hardware by size. A plastic ice-cube tray or muffin baking pan is very handy for keeping small parts and hardware separate. It will also prevent misplacement.

NOTE: Since hardware is weighed rather than counted, you will find that you have extra screws, nuts and lockwashers. Also, we have given you extra wire in case you should need some. Take your time and work slowly. We want you to enjoy building your VFO, as well as using it when it is completed.

THIS KIT MUST BE PROPERLY SOLDERED!

USE ENOUGH HEAT

This is the main idea of good soldering. Apply enough heat to the metal surfaces you are joining to make the solder spread freely, until the contour (shape) of the connection shows under the solder.

AN ELECTRONIC UNIT WILL NOT WORK . . . unless it is properly soldered. Read these instructions carefully to understand the basic ideas of good soldering.

Enough heat must be used so the solder can actually penetrate the metal surfaces, making an unbroken path over which electricity can travel. You are not using enough heat if the solder barely melts and forms a rounded ball of rough, flaky solder.

Use the Right Soldering Tool

A soldering iron in the 27-40 watt range is recommended. Any iron in this range with a clean, chisel-shaped tip will supply the correct amount of heat to make a good solder connection. You may also use a solder gun but make sure the tip reaches full heat before you solder.

Keep the iron or gun tip brightly coated with solder. When necessary, wipe the hot tip clean with a cloth. If you are using an old tip, clean it before you start soldering.

Use Only Rosin Core Solder

We supply the right kind of solder (*rosin core solder*). Do not use any other kind of solder! **Use of Acid Core Solder, Paste, or Irons Cleaned on a Sal Ammoniac Block will ruin any Electronic Unit and will Void the Guarantee.**

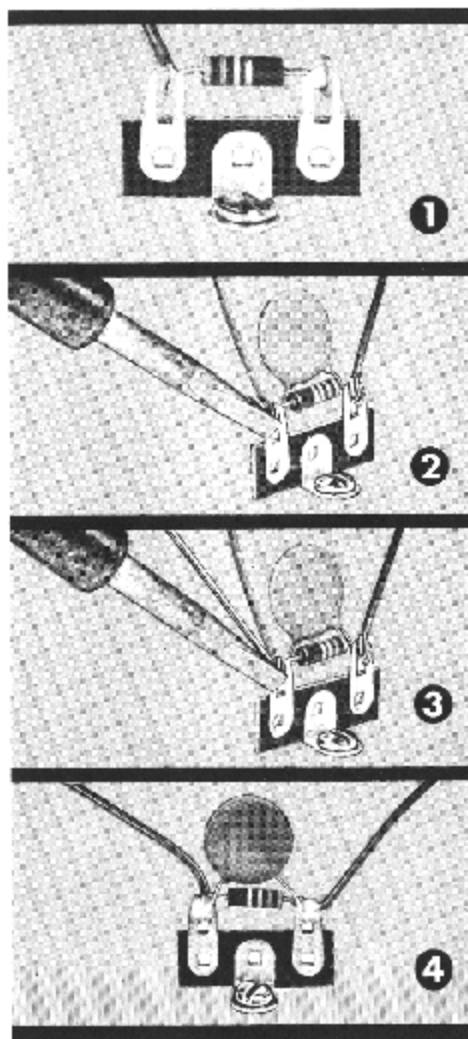

HERE'S HOW TO DO IT . . .

1. Join bare metal to bare metal; insulation must be removed. Make good mechanical connections and keep resistor and capacitor leads as short as possible, unless otherwise specified.

2. Coat the tip of a hot iron with solder. Then **Firmly Press the Flat Side of the Tip** against the parts to be soldered together. Keep the iron there while you . . .

3. Apply the solder between the metal to be soldered and the iron tip. Use only enough solder to flow over all surfaces of the connection, and all wires in the connection. Remove the iron.

Do Not Move Parts Until the Solder Hardens. If you accidentally move the wires as the solder is hardening, apply your iron and reheat.

4. Compare your soldering with the pictures on this page. You have a good connection if your solder has flowed over all surfaces to be connected, following the shape of the surfaces. It should appear smooth and bright and all wires in the connection should be well-soldered.

You Have Not Used Enough Heat: If your connection is rough and flaky-looking, or if the solder has formed a round ball instead of spreading.

The difference between good soldering (enough heat) and poor soldering (not enough heat) is just a few extra seconds with a hot iron **firmly** applied. **REMEMBER, LARGER METAL SURFACES TAKE A LONGER TIME TO HEAT.**

MOUNTING PARTS ON THE CHASSIS

SEE FIGURE 1.

- ☑ Position the chassis in front of you as shown in Figure 1.
- ☑ V-1, 7-pin tube socket and tube shield base. Mount the shield base from the top of the chassis and the tube socket from inside the chassis as shown in Figure 2. Position the socket with the keyway (wide space between two pins) as shown in Figure 1. Use two 4-40 x 1/4" screws, lockwashers and nuts.
- ☑ V-2, 7-pin tube socket and tube shield base. Mount as above. Be sure to position the socket so the keyway is as shown.
- ☑ Three small grommets. Press into the holes in the chassis where shown.
- ☑ One large grommet. Press into the hole in the rear of the chassis where shown.
- ☑ TS-1, 2-terminal strip. Mount with a 6-32 x 1/4" screw, two lockwashers and a nut. Place one lockwasher between the mounting foot and the chassis and the other between the mounting foot and the nut.
- ☑ TS-2, 3-terminal strip. Mount with a 6-32 x 1/4" screw, two lockwashers and a nut. Again, place a lockwasher on each side of the mounting foot.
- ☑ TS-3, 4-terminal strip. Mount with a 6-32 x 1/4" screw, two lockwashers and a nut. Place a lockwasher on each side of the mounting foot.
- ☑ TS-4, 1-terminal strip. Mount with a 6-32 x 1/4" screw, two lockwashers and a nut. Place a lockwasher on each side of the mounting foot.
- ☑ C-2, trimmer capacitor. Bend the lugs at right angles so they fit into the holes in the chassis. Mount from the top of the chassis with two 4-40 x 3/8" screws, a lockwasher, a solder lug and two nuts. Mount the solder lug on the screw closer to TS-2. Caution: Do not overtighten these screws. See Figure 9 for a top view of the chassis and C-2.
- ☑ L-2, output coil in a metal can. Position with the color dot as shown. Mount with the "U" shaped clip as shown in Figure 3.
- ☑ L-1, oscillator coil. Mount as shown in Figure 4. Be sure the locating pin is correctly positioned before pushing the locking tab through the chassis.
- ☑ S-1 rocker switch. Mount with two #4 self-tapping screws and two lockwashers; place the lockwasher directly under the head of the screw.
- ☑ Clip nut. Snap over the hole in the front lip of the chassis — with the raised side of the clip facing down into the chassis.
- ☑ Bend the ground lugs on each tube socket away from the socket pins and down toward the chassis. Also, bend the tube socket pins slightly outward to provide more spacing between pins.

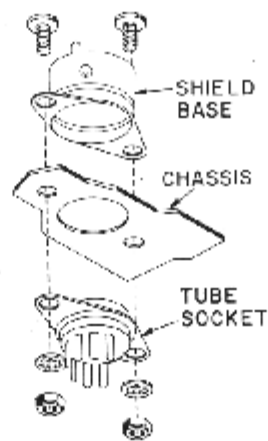

FIGURE 2

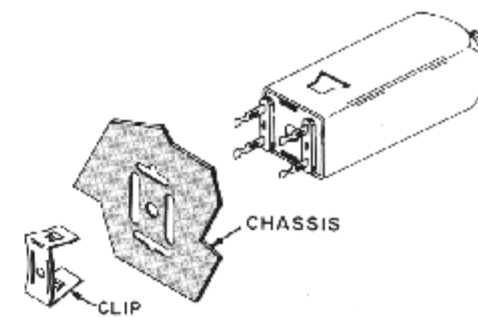

FIGURE 3

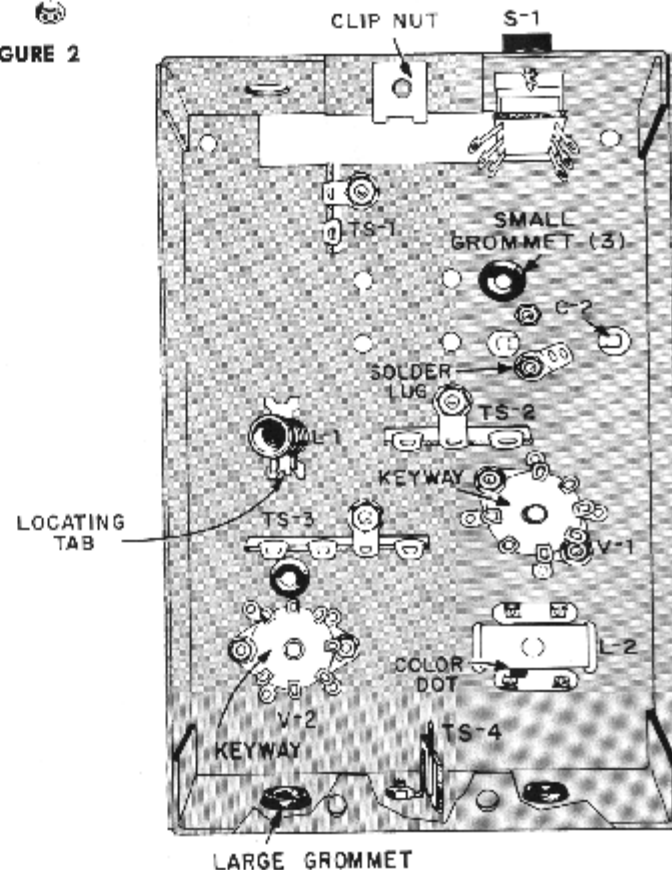
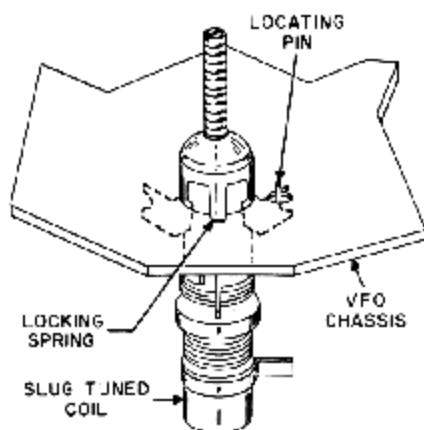

FIGURE 1

FIGURE 4



FIRST WIRING

IMPORTANT INSTRUCTIONS

THE INSTRUCTION CONNECT MEANS: Connect the wire or lead to the given point. Make a firm mechanical connection **BUT DO NOT SOLDER AT THIS TIME**. Later another wire(s) will be connected to this point.

THE INSTRUCTION SOLDER MEANS: Connect the wire or lead to the given point and then solder the connection and all wires in it. If there is more than one wire in the connection, the number will be stated — for example (2 wires). After soldering a connection, trim all wires as close as possible to the terminal.

SEE FIGURE 5.

- Blue wire. Solder one end to terminal 2 of S-1. Connect the other end to terminal 1 of TS-3.
- Violet wire. Connect one end to terminal 1 of S-1. Connect the other end to terminal 1 of TS-4.
- R-4, 100K resistor (brown, black, yellow). Solder one lead to terminal 1 of S-1 (2 wires). Connect the other end to terminal 2 of TS-1.
- C-10, .02 μ f disc capacitor. Connect one lead to ground lug D of V-1. Slip $\frac{1}{4}$ " of tubing over the other lead and connect it to terminal 3 of L-2.
- Orange wire. Connect one end to pin 6 of V-1. Solder the other end to pin 5 of V-2.
- Orange wire. Solder one end to pin 4 of V-1. Connect the other end to terminal 2 of TS-3.
- $1\frac{1}{2}$ " bare wire and $\frac{3}{4}$ " of tubing. Slip the tubing over the wire and solder one end of the wire to pin 2 of V-2. Connect the other end to terminal 4 of TS-3.

- $1\frac{1}{2}$ " of bare wire and $\frac{3}{4}$ " of tubing. Connect one end of the wire to terminal 1 of C-2. Pass the other end of the wire down through the small grommet and slip the tubing over the wire from the top of the chassis.
- $\frac{1}{2}$ " of bare wire. Solder one end to terminal 2 of C-2. Solder the other end to the solder lug mounted with C-2.
- C-3, 51 pf mica capacitor. Solder one lead to terminal 1 of C-2 (2 wires). Connect the other end to terminal 3 of TS-2.
- R-1, 47K resistor (yellow, violet, orange). Connect one lead to terminal 1 of TS-2. Connect the other end to ground lug A on V-1.
- C-7, 750 pf mica capacitor. Solder one lead to ground lug A of V-1 (2 wires). Connect the other lead to pin 2 of V-1.
- $1\frac{1}{2}$ " bare wire. Thread the wire through ground lug D of V-1, pin 7 of V-1, the center pin, pin 3 and solder to ground lug B of V-1. Solder ground lug D (2 wires), pin 7 and pin 3.
- $1\frac{1}{4}$ " bare wire. Solder one end to terminal 3 of L-2 (2 wires). Connect the other end to terminal 1 of TS-4.

FIGURE 5

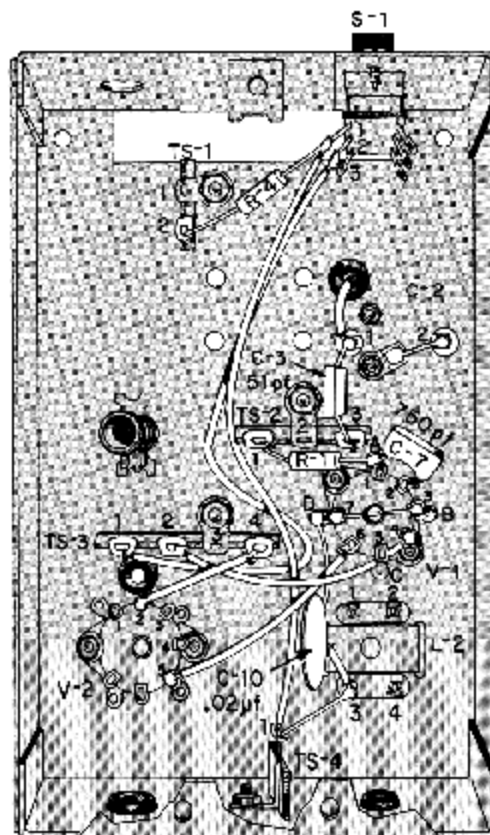

SECOND WIRING

SEE FIGURE 6.

- ☒ $2\frac{1}{2}$ " bare wire and $1\frac{1}{2}$ " of tubing. Connect one end of the wire to terminal 2 (lower terminal) of L-1. Do not put any tension on the terminals of L-1; they may move and slip off under strain. Slip the tubing over the wire and connect the other end to terminal 3 of TS-2.
- ☒ C-4, 47 pf disc capacitor. Solder one lead to terminal 2 of TS-2. Solder the other lead to terminal 3 of TS-2 (3 wires).
- ☐ R-2, 47 ohm resistor (yellow, violet, black). Connect one lead to terminal 1 of TS-2. Solder the other lead to pin 1 of V-1.
- ☒ RFC-1. Slip $\frac{1}{2}$ " of tubing over one lead and connect it to pin 2 of V-1. Connect the other lead to terminal 4 of TS-3.
- ☐ C-9, .01 μ f disc capacitor. Solder one lead to the center pin of V-1 (2 wires). Solder the other lead to pin 6 of V-1 (2 wires).
- ☐ Single conductor shielded cable. Prepare the ends as shown in Figure 7. Pass one end of the cable through the small grommet in the rear of the chassis and connect the inner conductor to terminal 2 of L-2. Slip $\frac{3}{4}$ " of tubing over the shield and solder it to ground lug C on V-1.
- ☐ Three conductor shielded cable. Carefully cut back 1" of the outer insulation from each end of the cable. Remove $\frac{1}{4}$ " of insulation from the ends of the wires. Carefully coat the bare ends of the wire with solder. Pass one end of the cable through the large grommet in the rear of the chassis and connect the wires as follows:
 - ☒ Solder the red wire to terminal 1 of TS-3 (2 wires).
 - ☒ Connect the black wire to terminal 2 of TS-3.
 - ☒ Connect the shield wire to terminal 3 of TS-3.
 - ☒ Connect the white wire to terminal 4 of TS-3.
- ☒ C-8, .02 μ f disc capacitor. Solder one lead to terminal 3 of TS-3 (2 wires). Solder the other lead to terminal 4 of TS-3 (4 wires).
- ☒ C-11, .001 μ f disc capacitor. Connect one lead to terminal 1 of L-2. Solder the other lead to terminal 2 of L-2 (2 wires).

COAT INNER CONDUCTOR TIP WITH SOLDER.

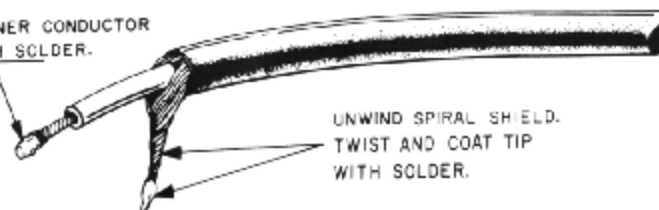

UNWIND SPIRAL SHIELD.
TWIST AND COAT TIP WITH SOLDER.

FIGURE 7

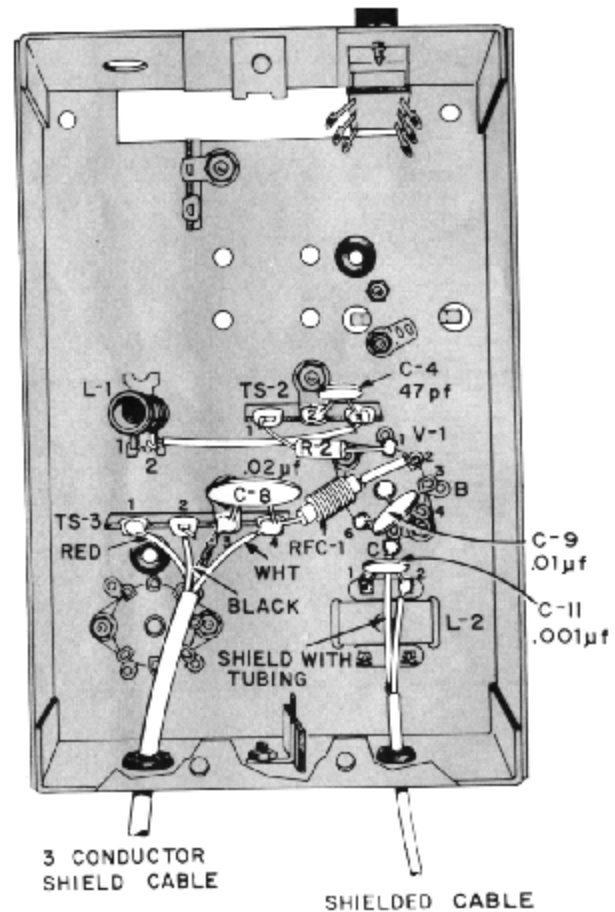

FIGURE 6

ASSEMBLY AND MOUNTING OF THE TUNING CAPACITOR

SEE FIGURE 8.

- ☑ C-1 tuning capacitor and tuning dial. Slip the tuning dial over the shaft of C-1. Position the dial so the bushing is about $\frac{1}{4}$ " away from the frame of C-1. Fasten with the set screw.
- ☑ Mount C-1 with its mounting bracket on the top of the chassis with four 6-32 x $\frac{5}{8}$ " screws, four flat washers and a solder lug. Place the solder lug under the screw nearest L-1 oscillator coil. **Do not over tighten these screws.**
- ☑ Pilot lamp and pilot lamp socket. Insert the pilot lamp into the socket. Mount the socket with a 6-32 x $\frac{1}{2}$ " screw, a solder lug and a lock-washer. Position the socket so the lamp is directly behind the center of the tuning dial.
- ☑ Green wire. Solder one end to the terminal on the socket that is nearest the front. The other end will be connected later.

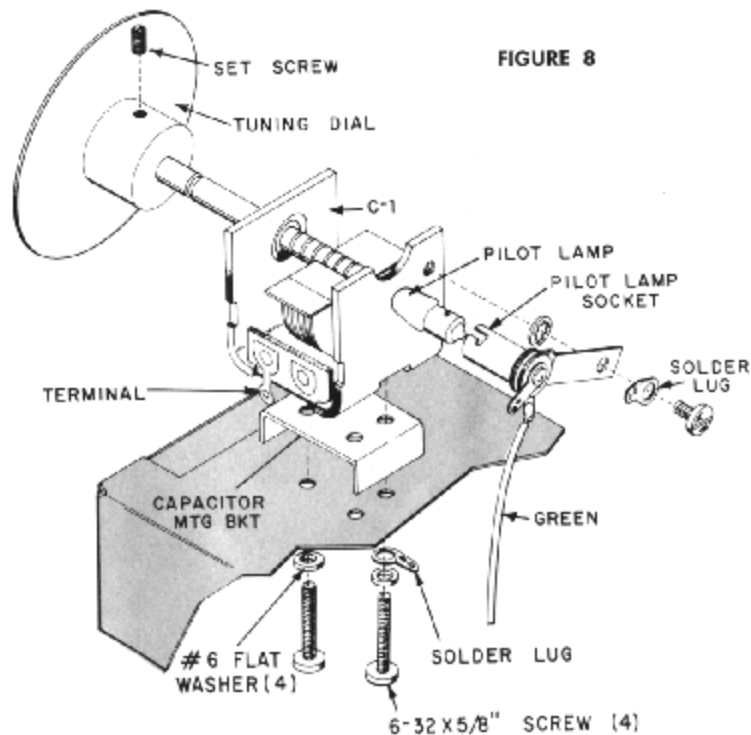

FIGURE 8

WIRING THE TOP OF THE CHASSIS

SEE FIGURE 9.

- ☑ Green wire from the pilot lamp socket. Insert the free end down through the small grommet shown.
- ☑ R-5, 47 ohm 1-watt resistor (yellow, violet, black). Solder one lead to the solder lug mounted with the pilot lamp socket. Solder the other lead to terminal 1 of the pilot lamp socket.
- ☐ Bare wire with tubing inserted up through the small grommet near C-1. Solder the end of the wire to the terminal of C-1.

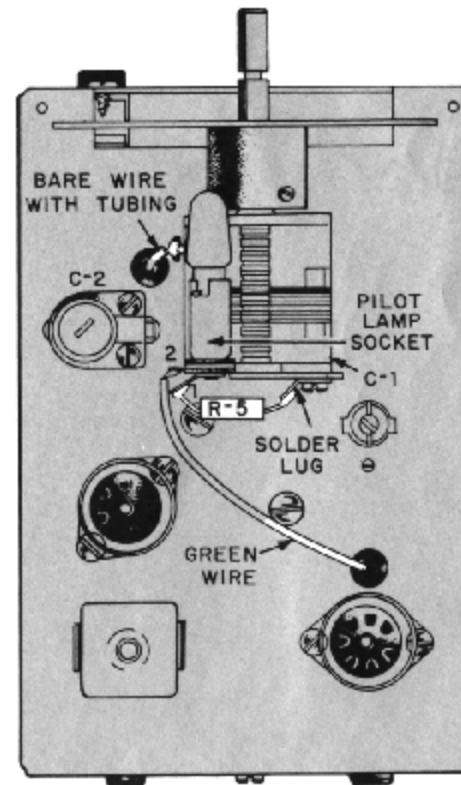

FIGURE 9

ASSEMBLING THE FRONT PANEL

SEE FIGURE 10 AND 11.

- OPERATE neon lamp. Insert through the front panel as shown — from the front side. Slip the large metal washer over the lamp.
- Dial window and front panel bracket. Remove the protective paper covering from the dial window. Assemble as shown with a bushing, flat washer, lockwasher and nut. Position the dial window so the edges line up square with the edges of the panel, and the "L" shaped sections of the bracket are even and parallel with the receding edge of the front panel.

- Slip the bushing on the front panel assembly over the shaft of C-1 and the leads of the OPERATE lamp through the hole in the front of the chassis. Fasten the assembly to the chassis with two #6 self-tapping screws threaded down through the "L" shaped sections on the front panel bracket and into the chassis.

NOTE: You may find it necessary to loosen the bushing and position the panel and bracket assembly to assure best fit of the shaft of the tuning capacitor and the rocker switch.

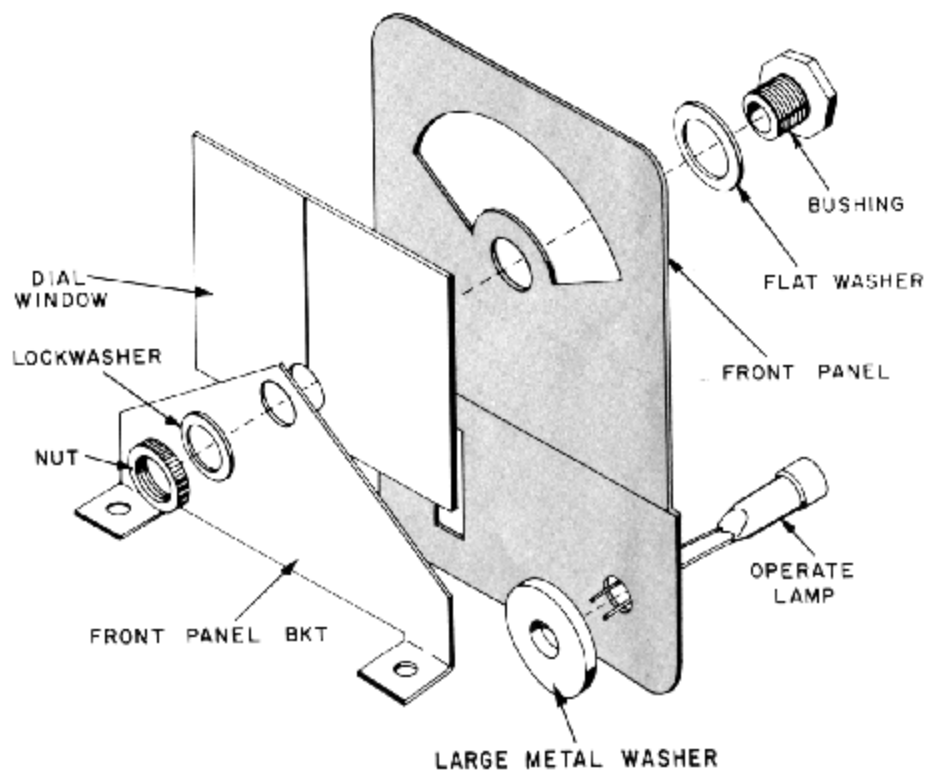

FIGURE 10

LAST WIRING

SEE FIGURE 11.

- ☐ Slip the clip supplied with the OPERATE lamp over the leads and body of the lamp. Press the clip firmly against the chassis, it will hold the lamp tightly in place. Note: Position the clip so its teeth are out and away from the chassis.
- ☐ Slip $\frac{1}{2}$ " of tubing over one lead of the OPERATE lamp and solder it to terminal 1 of TS-1. Slip $\frac{3}{4}$ " of tubing over the remaining lead and solder it to terminal 2 of TS-1 (2 wires).
- ☐ C-5, 10 pf disc capacitor. Connect one lead to terminal 2 of L-1. Again, take care not to strain the terminals of L-1. Connect the other lead to the solder lug near L-1.
- ☐ C-12, 10 pf disc capacitor. Solder one lead to terminal 2 of L-1 (3 wires). Solder the other lead to the solder lug near L-1 (2 wires).
- ☐ $1\frac{1}{4}$ " bare wire. Connect one end to terminal 1 of TS-2. Solder the other end to terminal 1 of L-1.
- ☐ C-6, 750 pf mica capacitor. Solder one lead to terminal 1 of TS-2 (4 wires). Slip $\frac{1}{2}$ " of tubing over the other lead and solder it to pin 2 of V-1 (3 wires).
- ☐ Green wire extending up through the grommet near TS-3. Solder the end to terminal 2 of TS-3 (3 wires).
- ☐ $\frac{3}{4}$ " bare wire. Solder one end to pin 5 of V-1. Solder the other end to terminal 1 of L-2 (2 wires).
- ☐ R-3, 2.5K, 7-watt resistor. Solder one lead to pin 1 of V-2. Solder the other lead to terminal 1 of TS-4 (3 wires).
- ☐ Two clip nuts. Snap one over each hole in the rear lip if the chassis — with the raised side of the clip facing down into the chassis.
- ☐ You have now completed all the wiring and soldering in your VFO. Carefully check all your work.
 1. Check to be sure all leads are kept as short as possible.
 2. Check to be sure all excess wire ends have been cut off.
 3. Check each solder connection to be sure it has been made properly. Reheat any doubtful connections, adding a little solder if necessary.
- ☐ Plug the 12DK6 tube into the V-1 socket. Place the small tube shield over the tube and twist into the locked position.
- ☐ Plug the OA2 tube into the V-2 socket. Place the large tube shield over the tube and twist into the locked position.

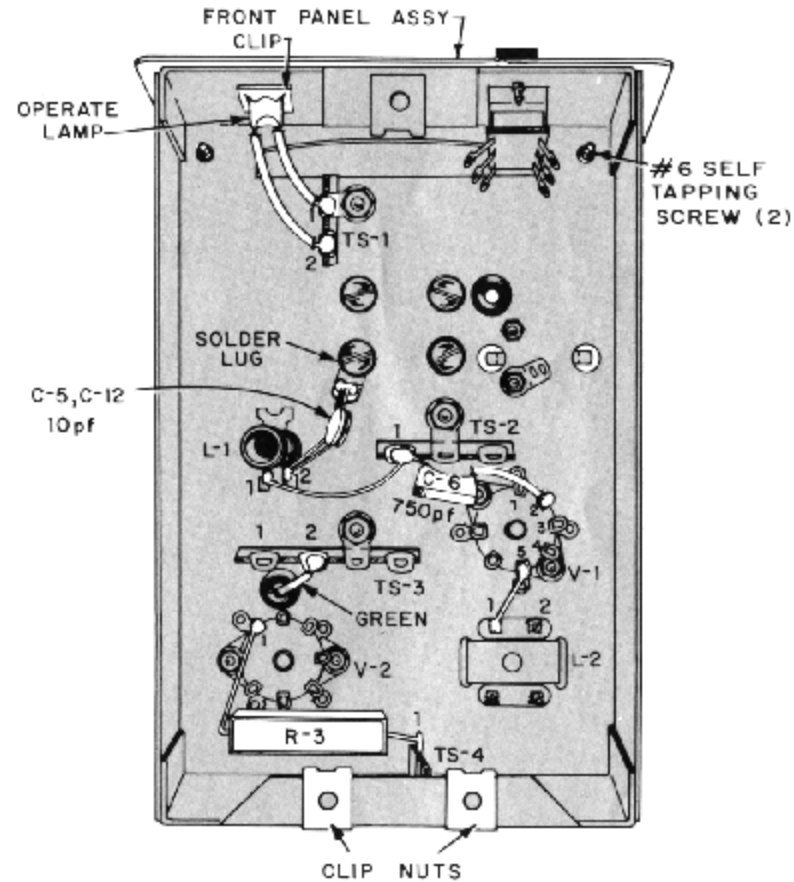

FIGURE 11

SEE FIGURE 12.

- Fasten the rubber feet to the bottom half of the case with four 6-32 x 5/16" screws, lockwashers and nuts.
- Fasten the bottom of the case to the chassis with three 6-32 x 5/16" screws.
- Fasten the top of the case to the bottom with four #4 self-tapping screws.
- Place the knob on the shaft of the tuning capacitor and tighten the set-screw against the flat side of the shaft.

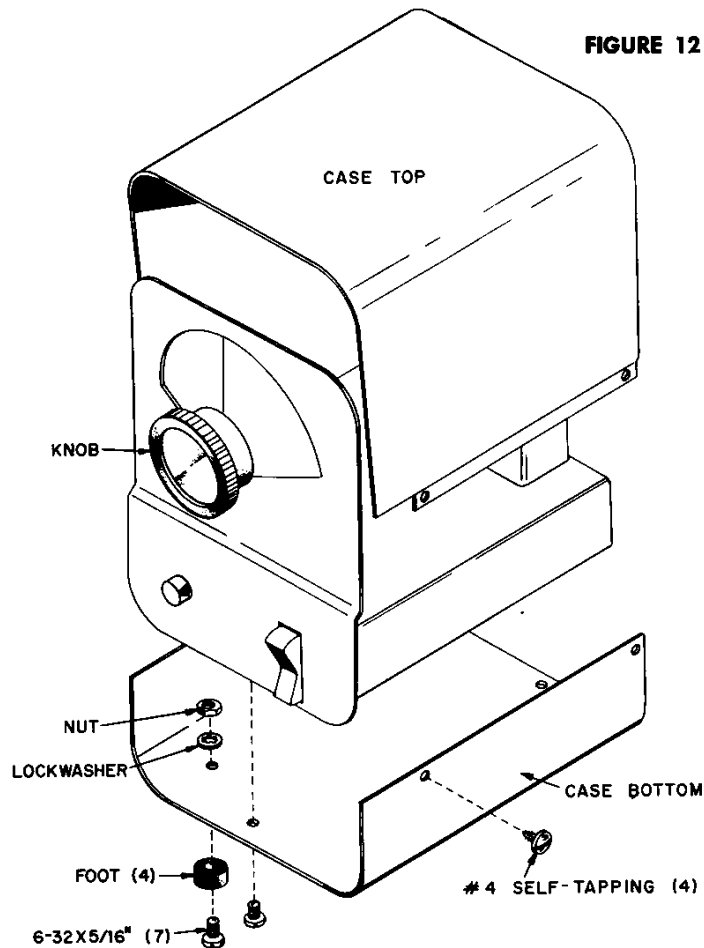

FIGURE 12

CONNECTING THE OUTPUT CABLES

The single conductor shielded cable is the VFO output. We have supplied a standard pin plug for this cable. If you prefer to use some other terminating connector, attach it at this time. Keep one thing in mind — this cable should be as short as possible to maintain maximum output from the VFO. The cable adds to the output capacity, which reduces the output. The output specification (20 volts RMS into 47K shunted by 30 pf) is at the end of the 24" cable. This output figure will be higher for shorter lengths of cable.

The 3 conductor shielded cable is for power. A four pin connector is supplied. Attach this connector to the end of this cable if you intend to use the VFO with a transmitter or transceiver which is equipped with a mating socket.

For example, connect it as follows when using the VFO with the matching 6 or 2 meter transceiver:

- Pin 1 — connect the shield wire to this pin.
- Pin 2 — connect the black wire to this pin.
- Pin 3 — connect the red wire to this pin.
- Pin 4 — connect the white wire to this pin.

CAUTION When you use this VFO with the matching transceivers, be sure this plug is properly connected to the socket on the transceiver — the screw-head positioned toward the 12-pin power connector.

For use with other units, keep the following in mind:

The shield wire is grounded internally, so it can be used for the negative, or ground-return circuit.

The black wire is for the filament voltage. The VFO requires 12.6 volts at 150 ma.

The red wire is for B+. This circuit may be switched by the control circuitry in the transmitter. The VFO requires 200 volts DC at 30 ma (voltage range from 180 to 230). Notice that this B+ line is controlled internally by the OPERATE-STANDBY switch. Thus, any external control switching will be in addition to the internal switching.

The white wire is for a ground return for the oscillator cathode and the B+ circuit. This circuit must be switched to ground by an external control circuit when the VFO is to be in the circuit. If the transmitter you are using does not have provision for grounding this circuit, the white wire can be connected internally to ground, then, the entire control must be by switching B+ only.

CALIBRATING THE VFO

The VFO must be calibrated against a frequency standard. The most readily available accurate frequency source is a crystal. If an electronic counter is available, it is the most versatile. Another possibility is a general coverage receiver that can tune the range of 8.0 to 8.666 mc.

Place the VFO in the case; the bottom cover fastened with the screws and the top just set in place.

- Turn the power on for the VFO and allow it and the calibration equipment to warm up for at least $\frac{1}{2}$ hour.
- Place a 47K resistor across the output cable of the VFO to serve as the recommended load.

CALIBRATION FOR 6 METER USE

- Remove the top cover from the VFO.
- Loosen the set-screw in the bushing of the tuning dial. Rotate the shaft of the tuning capacitor so the plates are all the way open. Now rotate the tuning dial on the shaft so the line on the window lines up with the red line just above 52 mc, on the tuning dial. Position the dial as close to the front panel as possible, without rubbing, and tighten the set-screw.

Calibration should be made at the most convenient dial mark near the edges of the tuning range. The recommended calibration points are 50.1 mc and 51.9 mc.

Use an 8350 kc crystal to calibrate the low end. If your transmitter has a spotting feature, use this function to obtain the required calibration signal. Place the VFO output cable near the antenna connector of the receiver.

- Set C-2 as shown below.
- Set the VFO dial to 50.1 mc. Adjust L-1 to zero-beat the VFO frequency with the crystal frequency.

Change to an 8650 kc crystal.

- Set the VFO dial to 51.9 mc. Adjust C-2 to zero-beat the VFO frequency with the crystal frequency.

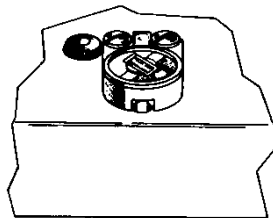

Setting of C-2
for 6 Meters

- Repeat the calibration at both ends of the dial until dial markings line up correctly.
- Set the VFO to the center of the range in which you intend to operate it. Remove the 47K load from the end of the output cable. Plug the output cable into your transmitter and adjust L-2 to obtain maximum drive into the transmitter.

CALIBRATION FOR 2 METER USE

- Remove the top cover from the VFO.
- Loosen the set-screw in the bushing of the tuning dial. Rotate the shaft of the tuning capacitor so the plates are all the way closed. Now rotate the tuning dial on the shaft so the line on the window lines up with the red line just below 144 mc on the tuning dial. Position the dial as close to the front panel as possible, without rubbing, and tighten the set-screw.

Calibration should be made at the most convenient dial mark near the edges of the tuning range. The recommended calibration points are 144.4 mc and 147.6 mc.

Use an 8022.2 kc crystal to calibrate the low end. If your transmitter has a spotting feature, use this function to obtain the required calibration signal. Place the VFO output cable near the antenna connector of the receiver.

- Set C-2 as shown below.
- Set the VFO dial to 144.4 mc. Adjust L-1 to zero-beat the VFO frequency with the crystal frequency.

Change to an 8205.5 kc crystal.

- Set the VFO dial to 147.6 mc. Adjust C-2 to zero-beat the VFO frequency with the crystal frequency.
- Repeat the calibration at both ends of the dial until the dial markings line up correctly.
- Set the VFO to the center of the range in which you intend to operate it. Remove the 47K load from the end of the output cable. Plug the output cable into your transmitter and adjust L-2 to obtain maximum drive into the transmitter.

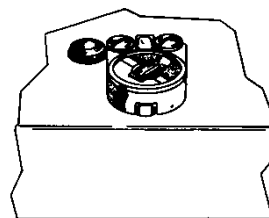

Setting of C-2
for 2 Meters

OPERATION

CONTROL FUNCTIONS

TUNING DIAL—varies the frequency at which the VFO operates. Read the frequency directly from the dial. The two-scale dial can be used for either 6 or 2 meter operation.

OPERATE-STANDBY SWITCH—turns the B+ on and off internally. In the STANDBY position, the B+ is removed from the circuit, but the filament power remains on. In the OPERATE position, B+ is applied to the circuit and the neon operate light goes on. **NOTE:** When using crystal control for your transmitter, leave the VFO in the STANDBY position. Even though the output from the VFO is not controlling the frequency of transmission, the internal tuned circuit will have an effect on the crystal frequency (especially if it is near the VFO dial frequency).

VFO OUTPUT cable—the single-conductor shielded cable feeds the output signal from the VFO to the transmitter. Use either the pin plug provided or a connector suitable for your application.

POWER cable—the three-conductor shielded cable provides the necessary wires for connecting power to the VFO. Use either the 4-pin plug supplied, or a connector suitable for your application.

CAUTION: When you use this VFO with the matching transceivers, be sure this plug is properly connected to the socket on the transceiver—the screw-head positioned toward the 12-pin power connector.



OPERATING HINTS

Always let the VFO warm up for at least 30 minutes before using it. This will assure maximum stability of frequency.

The output from this VFO is more than adequate to drive most transmitters (minimum of 20 volts RMS). Even greater output may be obtained by shortening the output cable. The capacity of the output cable loads down the RF output; thus, the shorter the cable the less the loading effect.

When using the VFO, do not operate too near the edges of the band. A very slight change in the VFO frequency could place your signal outside of the band limits.

When you use this VFO with a transmitter that does not have control switching circuitry to turn the VFO on and off, it is imperative that you turn the VFO on before the transmitter and then the transmitter off before the VFO. Thus, the VFO is the first on and the last off. This will assure proper bias for all stages of the transmitter. Without grid drive, most transmitter stages will draw excessive current and exceed tube dissipation, which may result in permanent damage to the tube.

Most transmitters will have suitable control switching to turn B+ to the VFO on and off. In such cases, the OPERATE-STANDBY switch may be left in the OPERATE position. All control of the VFO will then be made at the transmitter. To simplify operation with this type of control, connect the white wire in the power cable to chassis ground. See page 10 for further information.

If you use this VFO with a transmitter which has a control switching function that will provide shorting contact when in the transmit function, use these contacts for the white wire and the shield wire of the power cable. The white wire is the cathode return and B+ return for the VFO, and must be connected to chassis ground when in operation. See page 10 for further information.

Remember that F.C.C. requires that you have a frequency measuring device separate from the controlling frequency. This device is to be used to monitor the output frequency of the transmitter. The dial calibration of your receiver is not considered acceptable, unless it is adjustable and a crystal calibrator is used as a standard for dial calibration tracking. Your transmitting crystals are not suitable for this requirement. This is an important regulation that is all too often overlooked by the Amateur Radio Operator.

PARTS LIST

CAPACITORS

All capacitors are ceramic disc, 20% tolerance, 500-600 volt, unless otherwise specified. Given voltage ratings are the minimum allowable. Capacitors supplied may have a higher voltage rating.

Symbol	Description	Part Number
C-1	Tuning (5.8 to 26 pf)	286-098
C-2	4-25 pf, NPO, ceramic trimmer	284-004
C-3	51 pf, 5%, silver mica	266-519
C-4	47 pf, 10%, NPO	278-070
C-5	10 pf, 10%, N-470	278-062
C-6	750 pf, 5%, mica	266-551
C-7	750 pf, 5%, mica	266-551
C-8	.02 μ f	276-025
C-9	.01 μ f	276-015
C-10	.02 μ f	276-025
C-11	.001 μ f	276-016
C-12	10 pf, 10%, N-470	278-062

COILS

Symbol	Description	Part Number
L-1	Oscillator	162-157
L-2	VFO output	142-132
RFC-1	2.5 mh choke	161-006

CONNECTORS

Symbol	Description	Part Number
P-1	4-pin, VFO power	509-079
P-2	Phono plug, VFO output	502-123

PILOT LAMPS

Symbol	Description	Part Number
PL-1	#47 bulb	640-002
PL-2	Neon bulb with clip	642-000

RESISTORS

Resistance in ohms. All resistors are 1/2 watt, 10% carbon composition, unless otherwise specified.

Symbol	Description	Part Number
R-1	47K	301-473 ✓
R-2	47	301-470 ✓
R-3	2.5K, 7 watt, wire-wound	373-006 ✓
R-4	100K	301-104 ✓
R-5	47, 1 watt	304-470 ✓

SWITCH

Symbol	Description	Part Number
S-1	DPDT, rocker: STANDBY-OPERATE	437-150

TERMINAL STRIPS

Symbol	Description	Part Number
TS-1	2-terminal	440-202
TS-2	3-terminal	440-301
TS-3	4-terminal	440-401
TS-4	1-terminal	440-101

TUBES

Symbol	Description	Part Number
V-1	12DK6	610-071 ✓
V-2	OA2	610-019 ✓

MISCELLANEOUS

Description	Quantity	Part No.
Base, tube shield, for 7 pin	2	511-055
Bracket, capacitor mounting	1	470-796
Bracket, front panel	1	470-795
Bushing	1	470-075
Case	1	702-114
Chassis	1	463-616
Dial	1	040-244
Dial window	1	870-183
Feet, rubber	4	831-001
Front panel	1	463-617
Grommet, large	1	830-003
Grommet, small	3	830-001
Knob	1	765-092
Socket, 7-pin tube	2	509-056
Socket, pilot lamp	1	509-090
Tube shield, large	1	511-058
Tube shield, small	1	511-052
Tuning tool	1	957-007

HARDWARE

Description	Quantity	Part No.
Clip nut	3	531-009
Lockwashers		
#4	7	582-200
#6	17	582-300
3/8"	1	582-701
Nuts:		
4-40	6	570-221
6-32	8	570-340
3/8"-32, knurled dress	1	579-754
Screws:		
4-40 x 1/4"	4	560-222
4-40 x 3/8"	2	560-224
#4 x 1/4" self-tapping	6	562-295
6-32 x 1/4"	5	560-342
6-32 x 5/16"	7	560-343
6-32 x 3/8"	4	560-348
#6 x 5/16" self-tapping	2	562-393
8-32 set-screw	1	563-445
Solder lug	3	553-005
"U" clip	1	532-008
Washer, #6 metal	4	580-300
Washer, 3/8" metal	1	580-702
Washer, large metal	1	587-971

WIRE, SOLDER AND TUBING

Description	Quantity	Part No.
Bare wire, 18"	1	800-600
Cable, 3 conductor shielded, 24"	1	808-030
Cable, Single conductor shielded, 24"	1	808-026
Insulated hook up wire:		
3" orange	2	807-023
5" green	1	807-025
6" blue	1	807-026
7" violet	1	807-027
Solder, 5'	1	930-004
Tubing, 10"	1	812-006

CIRCUIT DESCRIPTION

The VFO is basically a highly stable Clapp oscillator with a voltage regulator tube used to stabilize the screen voltage on the oscillator tube.

The high degree of frequency stability is achieved by careful design and consideration of the following important points:

1. Temperature stability.
2. Mechanical stability.
3. Electrical stability.

Temperature stability is achieved in two ways.

The power supply is not included in the VFO. Thus, the greatest source of heat is eliminated.

The ambient temperature created by the circuit components is kept to a minimum. Power levels are kept to a minimum; thus, internally generated heat is kept to a minimum. Even the one source of heat dissipation, the series voltage-dropping resistor for the 0A2 tube, has been more than doubled (with respect to requirements) in dissipation capacity and physical size to reduce any heating effects.

Rugged construction is the key to mechanical stability.

The chassis is made of heavy gauge material. The box-construction provides added rigidity.

The two-piece wrap-around construction for the case provides a heavy supporting brace for the chassis. The bottom half of the case completes the box-construction of the chassis. The large-diameter, short-length ceramic coil form is held firmly in place under the spring tension mount. Thus, this important part of the frequency determining circuit is virtually immune to movement due to physical stress.

Change in value of the electrical parts is reduced by a number of precautions.

Ceramic construction of the coil form and trimmer capacitor provides a stable material for these important components. Thus, heat and temperature effects are greatly minimized.

Temperature compensating ceramic disc capacitors are used in all critical portions of the oscillator circuit. These compensate for electrical changes due to shifts in temperature.

Low temperature coefficient mica capacitors are used in the capacitive divider circuit. Also, the high ratio of these capacitors as compared to the internal tube capacity minimizes tube variations due to voltage and loading changes.

The electron-coupled oscillator provides excellent load isolation. The pentode tube also provides the additional isolation of a suppressor grid.

A voltage regulator tube is used to provide variation-free voltage to the screen of the oscillator tube. Since the screen is used as a plate in the oscillator circuit, the B+ operating potential for the oscillator is fully regulated.

Thus, as you can see, a great deal of care was taken when the VFO was designed.

The oscillator circuit is the famous series-tuned Colpitts, which is more commonly called the Clapp circuit. There are two main advantages of the Clapp circuit: the tube is tapped across only a small portion of the tank circuit, thus minimizing the effects of the tube on the resonant circuit and secondly, the internal tube capacity is shunted by high values of capacity. Thus, the tube becomes such a minor portion of the frequency-determining circuit, that its variations have little effect on the circuit.

Use of the high-gain pentode 12DK6 provides excellent isolation from load changes. The plate circuit of the tube is tuned to obtain maximum output.

The oscillator frequency is in the 8 megacycle range. No multiplying is done in the VFO circuitry. The bias point for the 12DK6 has been carefully chosen to produce a symmetrical output wave-form. The resonant circuit in the plate and output circuit helps to achieve a fairly clean sine-wave.

This feature is important because a high harmonic content can result in spurious radiation and eventually TVI, etc.

The STANDBY-OPERATE switch is in the B+ circuit. In the STANDBY position, the B+ circuit is opened and the oscillator will not function.

A neon indicator bulb (PL-2) is placed in the B+ circuit with a resistor in series to limit the current through the bulb. The neon bulb lights only when B+ is applied to the input power cable and the switch is in the OPERATE position.

A series voltage dropping resistor, R-3, limits the voltage applied to the plate of the voltage regulator tube, V-2. Its value is chosen so that the current drain through this circuit always remains within the regulation range of the 0A2.

The entire VFO circuit is designed to operate at minimum power so the heating effects are kept to a minimum. To obtain the required amount of RF output, a high-gain tube was chosen. This allows the circuit to run at minimum power levels and still have adequate RF output.

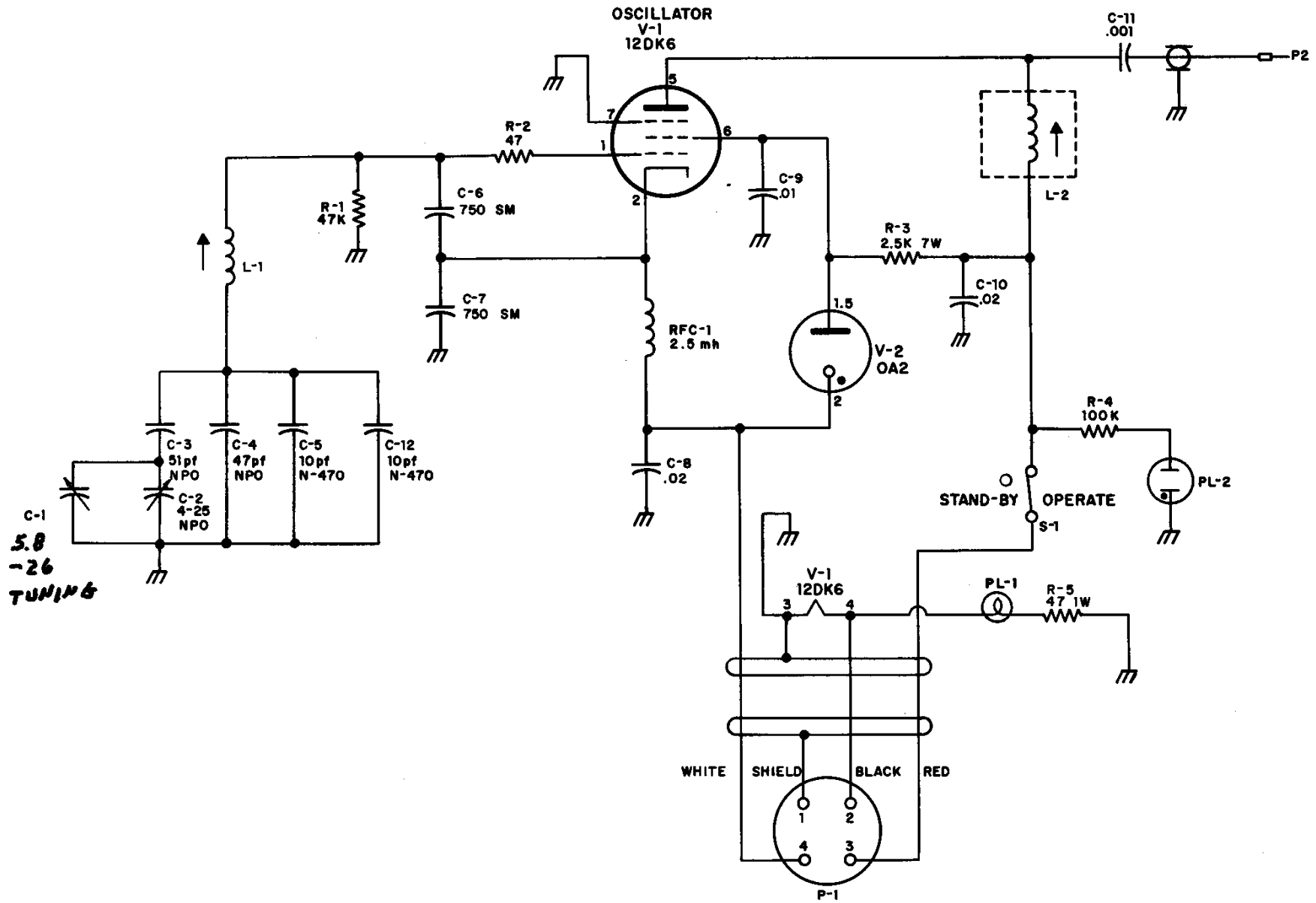

SCHMATIC DIAGRAM

KNIGHT-KIT SERVICE FACILITIES

TECHNICAL CONSULTING SERVICE

If, after following the instructions and suggestions given in this manual you are still unable to obtain proper performance from your kit, we invite you to contact our Technical Consulting Service for further assistance. Please be as accurate and thorough as possible because the effectiveness of our advice depends entirely on the information you supply.

Use the following as a guide for your correspondence:

1. Have you checked all the suggestions under Service Hints? Careful consideration of these points may solve your problem without writing.
2. Be sure to give the kit model number, the date of purchase and the serial numbers on the label pasted on the chassis and the back cover of the manual.
3. Have you made a thorough check of all wiring and soldering? Each solder connection should have a shiny metallic finish. Reheat any connection that appears doubtful and add a little solder if needed. Be sure there are no parts accidentally touching each other, the chassis or nearby terminals.
4. If the kit is of the type that requires calibration or alignment, double check these procedures. Be as specific as possible in your report. Outline adjustments made and the alignment procedure employed.
5. When you write be sure to describe all associated equipment. Specifically note the switch positions. Define as clearly as possible the symptoms as noted and mention any particular circumstance under which the problem occurs (after unit has been on for some time, only when jarred or moved, only when used for a particular purpose, etc.).
6. If you have completed the recommended service hints, be sure to outline the results and note any measurements taken which are out of tolerance.

KNIGHT-KIT PARTS WARRANTY

Knight Electronics guarantees that only premium-quality parts are selected for use in Knight-Kits. Every Knight-Kit part is fully warranted for a period of one year from date of purchase against defects in material and workmanship. Prompt No-Charge replacements of defective parts will be made.

INSPECTION SERVICE

You may return your completed Knight-Kit for inspection and repair within **one year from purchase** for a service charge of **\$7.00** for this particular kit. An additional charge will be made for parts damaged in construction.

Kits not completely wired or which require extensive re-work will incur an additional labor charge. You will be notified of these charges prior to our repairing your kit.

No service charge will be made for a **period of 90 days from date of purchase**, if malfunctioning of the completed kit is due to a defective part. Service charges for kits returned **after the one year period** will be on a time and materials basis.

PACKING INSTRUCTIONS

Should you find it necessary to return your Knight-Kit, be sure to pack it carefully. The original carton should be used, if available. If not, a sound carton of similar size may be used. **TO PREVENT COSTLY DAMAGE IN TRANSIT**, cushion your Knight-Kit tightly using plenty of packing material. Mark: **FRAGILE—DELICATE ELECTRONIC EQUIPMENT**.

SHIPPING INSTRUCTIONS

Ship your unit by Parcel Post **Insured**. Please include remittance to cover repair costs plus return postage and insurance. Postage and insurance may be estimated by referring to the "how to order page" in our catalog. This will save you costly COD fees; any excess remittance will be refunded.

When you return a kit please enclose your order papers and a letter explaining why you are returning the unit. On the front of the package print "**FIRST CLASS LETTER ENCLOSED**" and apply postage on the package for the enclosed letter.

ADDRESS CORRESPONDENCE AND RETURN KITS TO:

KNIGHT ELECTRONICS CORP.
Knight-Kit Service Department
2100 Maywood Drive • Maywood, Illinois