



REPAIR GUIDE

COMMUNICATION ACCESSORY

VFO

MODEL

HA-20

by Walt Cates WDOGOF 3/22/2022

MODEL HA-20



I, INTRODUCTION

The HA-20 is a VFO accessory unit designed to function with the Hallicrafters SR-400 series and the SR-2000 transceivers. It enables the operator to select transmit and receive frequencies that are separated by as much as 500KHz within any band segment. It also provides the choice of two transceive frequencies when manually switched between R&T and STBY. Another feature is the DUAL R function. The functions of this feature are available only in the receive mode. This feature has two functions. First, when switched on it allows the operator to zero beat the transceiver unit's VFO with the HA-20 VFO. Second, it allows for the simultaneous monitoring of two receive signals. These two frequencies can be separated by as little as 5KHz or as much as 500KHz.

The red panel lamp provides an indication of when the HA-20 is controlling the frequency. When the OPERATION switch is in either the OFF or the STBY position the attached transceiver operation is unaffected by the HA-20

An added feature of the HA-20 is a front panel indication of the condition of the antenna termination. The VSWR BRIDGE ASSEMBLY, is a separate assembly provided with the HA-20. When connected, it will provide an indication of relative power output and VSWR. This feature can be used in any system up to 450MHz. The power required for full scale forward meter reading varies with frequency and will be approximately 90 watts at 1.8MHz and 1 watt at 450MHz.

The full installation and operation instructions can be found in SR-400 series or the SR-2000, **HALLICRAFTERS OPERATING AND SERVICE INSTRUCTIONS** manuals. That manual is considered a required companion document to this **REPAIR GUIDE**. Be aware that some versions of the SR-2000 manuals do not contain the HA-20 documentation. You will need to acquire an HA-20 or SR-400 manual.

Table of Contents

I, INTRODUCTION	2
II, INSPECTION AND CLEANING	4
III, POWER SUPPLY TESTS	4
III-1, PRE-POWER UP TESTS	4
III-2, POWER ON VOLTAGE TESTS	4
IV, VSWR METER TESTS	5
IV-1 TEST SET UP CONDITIONS	5
IV-2, VSWR CIRCUIT TEST	5
IV-3, VSWR BRIDGE ASSEMBLY TEST	5
V, OPERATIONAL TEST	6
V-1, FUNCTION TEST	6
V-1-1, EQUIPMENT REQUIRED	6
V-1-2, TEST SETUP	6
V-1-3, FUNCTIONAL TEST	6
VI, VFO TRACKING AND ALIGNMENT	7
VI-1, GENERAL SPECIFICATION	7
VI-2, VFO CORRECTOR	7
VI-3, VFO STABILITY TEST	7
VI-4, VFO TRACKING	8
VII, VOLTAGE CHART	9
APPENDIX	10
APPENDIX 1, RF BLOCKING PROBE	10
APPENDIX 2, TEST POINTS	11

**My thanks to Mike, WB4JQY,
For allowing me to use his HA-20 to experiment with and
collect data.**

II, INSPECTION AND CLEANING

Most likely your “new” HA-20 has been sitting on someone’s shelf or hayloft for a number of years. It is a good idea to clean the chassis thoroughly. S1 and S2 should be cleaned and treated with a contact protectant. A product such as CRC CONTACT CLEANER & PROTECTANT (green can) is a good choice. It removes grease, dirt and oxidation and leaves a protective film to prevent further oxidation. R6 the CAL ADJ control and R15 the METER SENS control, should get a good spray of a quality potentiometer cleaner/lubricant.

Cleaning and lubrication of the main tuning drive is next. The mechanism in the HA-2 is exactly the same as the drive used in the SR-400 series and the SR-2000. Once the drive system has been cleaned and lubed the mechanical indexing needs to be checked. Section 8-8-A in either the 400 or 2000 manuals details this process.

III, POWER SUPPLY TESTS

III-1, PRE-POWER UP TESTS

The following tests are performed with the accessory cable and the power cord disconnected.

TEST POINT	SPECIAL INSTRUCTIONS	MEASUREMENT	ADDITIONAL INFO
T1 PRIMARY	S1 OFF	OPEN	
T1 PRIMARY	S1 STBY	12Ω	*100mh
T1 HV SEC.		46Ω	*350MH
T1 FIL. SEC.	PULL TUBES	0.7Ω	*4.2mh
A		>60KΩ	Tie-point of R16 and R17 to gnd.
B		>60KΩ	Tie-point of R17 and R18 to gnd
C		>60KΩ	Tie-point of R18 and R14 to gnd.
D	PULL V3	207KΩ	Pin 1 V3.

*Inductance was measured in circuit.

III-2, POWER ON VOLTAGE TESTS

TEST POINT	location	MEASUREMENT	MAX RIPPLE VOLTAGE
A	Tie-point of R16 and R17 to gnd.	265vdc +/- 10%	10vpp
B	Tie-point of R17 and R18 to gnd	230vdc +/- 10%	500mvpp
C	Tie-point of R18 and R14 to gnd.	215vdc +/- 10%	30mvpp
D	Pin 1 V3.	150vdc +/- 2vdc	30mvpp

IV, VSWR METER TESTS

IV-1 TEST SET UP CONDITIONS

The following tests will be performed with the HA-20 disconnected from the transceiver and AC power source. The VSWR bridge will not be connected. A 1.5v battery, two clip-leads and a DVM will be required. **NOTE: Any small voltage battery or DC source will work. A voltage between 0.75vdc and 3vdc is most desirable.**

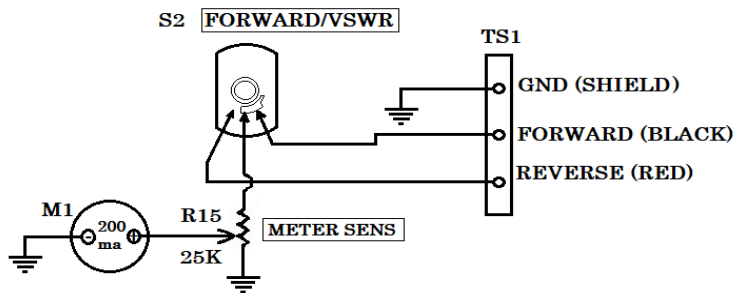

IV-2, VSWR CIRCUIT TEST

Turn the METER SENS to the max CCW position and set the switch to CALIB. Connect DVM to the + terminal of M1 or the wiper of R15 and the negative lead to the chassis.

- Connect the - side of the battery to TS1 GND. Connect the + side of the battery to the TS1 FORWARD terminal.
- Advance the METER SENS control until the meter reaches full scale.
- The DVM should read 0.125vdc +/- 10%.
- Leave the METER SENS in it's current positing. Set the meter switch to the VSWR position. Move + lead of the battery to the TS1 REVERSE terminal.
- M1 should once again read full scale.

IV-3, VSWR BRIDGE ASSEMBLY TEST

To test the bridge assy., you will need a transmitter with adjustable power output that will adjust to 90 watts on the 80 meter band. The HA-20 will be left off and unplugged from a transceiver or AC power.

- Connect the test transmitter to the bridge J1 connector and a wattmeter/50Ω load to J2 on the bridge.
- Turn the METER SENS control on the HA-20 to minimum (full CCW).
- Key the transmitter and adjust the power out to 90 watts.
- With the transmitter keyed, advance the METER SENSE control. The meter on the HA-20 should reach full scale deflection before you run out of adjustment.
- Reverse the connections of J1 and J2 on the bridge and repeat the procedure and you should get the same results.

V, OPERATIONAL TEST

•The following tests assume the 400 or 2000 you will be connecting to is fully functional and meets all minimum specifications. The bridge assembly will not be used in the following procedures. For the operational test the signal from the transceiver is “VFOx” and the signal from the HA-20 is VFOa

V-1, FUNCTION TEST

V-1-1, EQUIPMENT REQUIRED

- Dual trace scope with a minimum of 25MHz bandwidth.
- 2, 10X scope probes.
- A SR-400 or SR-2000 with power supply.
- HA-20.
- Microphone.

V-1-2, TEST SETUP

- Remove the bottom cover of the 400 or 2000.
- Set the transceiver RF and AF gain controls to fully CCW.
- Connect The accessory cable from the HA-20 to the accessory jack on the transceiver.
- Connect the scope probe from channel 1 of the scope to V4 pin 7 of the 400 or 2000.
- Connect the scope probe from channel 2 of the scope to V2 pin 7 of the HA-20.
- Connect microphone to the transceiver.

V-1-3, FUNCTIONAL TEST

For these tests it does not matter what band is selected or if the transceiver is tuned up at any frequency. This is a functional test of the HA-20. The transceiver must be connected and turned on to prove the HA-20 does in fact control the selection of the proper VFO for the various modes of operation.

- Set the controls of the transceiver per the following instructions.
- Set the FUNCTION switch to LSB or USB. ••Set the RIT to OFF. ••Set all the RF and AF gain controls to fully CCW. ••Set the OPERATION switch to MOX. ••When on, both VFO signals should be 1.6vpp or better.
- Set the HA-20 OPERATION control OFF.
 - >In this condition Channel 1 of the scope will display VFOx signal. Channel 2, no signal.
 - >Key the mic and Channel 1 continues to display VFOx signal. Channel 2, no signal.
- Set the HA-20 OPERATION control to STBY
 - >In this condition Channel 1 of the scope will display VFOx signal. Channel 2, no signal.
 - >Key the mic and Channel 1 continues to display VFOx signal. Channel 2, no signal.
- Set the HA-20 OPERATION control to T.
 - >In this condition channel 1 will display VFOx signal channel 2 no signal.
 - >Key the mic and channel 1 displays no signal and channel 2 displays VFOa signal.
 - >The red panel lamp on the HA-20 will turn on when the mic is keyed
- Set the HA-20 OPERATION control to R&T.
 - >In this condition channel 1 shows no signal with the mic unkeyed or keyed.
 - >Channel 2 displays the VFOa signal and the red panel lamp will turn on when the mic keyed or unkeyed.
- Set the HA-20 OPERATION control to DUAL R.
 - >This setting is a receive-only function. Both channels on the scope will display VFO signals
 - >The red panel lamp will be on.

VI, VFO TRACKING AND ALIGNMENT

The mechanical indexing should have been done in section III. If it was not done, proceed to Section 8-8-A in either the 400 or 2000 factory manual and complete this process. Additional test equipment for alignment and tracking is a frequency counter with 5 digit resolution at 4MHz.

VI-1, GENERAL SPECIFICATION

Frequency Stability; Less than 250 cycles drift in the first hour, after a fifteen-minute warm-up, and less than 100 cycles per hour thereafter.

VI-2, VFO CORRECTOR

The VFO correction ckt adjusts for the frequency off set between USB and LSB (NOTE: CW operates in the USB MODE). Before the VFO is aligned it must be established that the correction ckts are working properly. Connect the frequency counter to pin 8 of V2 of the HA-20. Connect the accessory cable to the transceiver. Set the transceiver operation switch to MOX and set the function switch to LSB. Set the HA-20 function switch to R&T. Tune the HA-20 main tuning until the frequency counter reads 4.5530 MHz (approx. 297 on the dial). Switch the transceiver function switch to USB and the frequency should drop 3000 Hz or to 4.5500 MHz. If not adjust C19 for exactly 4.5500. If you cannot then there is a fault in the corrector ckt that must be repaired before you can continue with the VFO alignment. There are only a few possibilities for this fault. First check the **offset switching voltage** on pin 4 of P2 (the ACCESSORY PLUG). In USB it should be 150 vdc. In LSB it should be a negative voltage in the range of -20 to -28 vdc. If the **offset switching voltage** is correct and the offset is un-settable then a wiring problem from pin 4 of P2 to C16 is possible. CR2, R8, C15 and/or C19 are most likely the cause. The off-set voltage is provided by the transceiver which has already been certified good.

VI-3, VFO STABILITY TEST

Before starting the VFO alignment perform a VFO stability test in LSB and USB modes. Connect the frequency counter to V2 pin8 (Temporarily move the probe from the counter to the scope you should see 1.6vpp minimum across the band in R&T MODE). Record the VFO frequency every 10 minutes for one hour. In the one-hour test it should meet the requirements as stated above. After 1 hour perform a short-term drift test by recording the freq every minute for 5 minutes. The short-term drift should not exceed 100 cycles. If the unit does not meet the stability requirements; First, clean all the chassis mounting hardware in the VFO enclosure. Remove screws, clean holes replace and tighten all hardware. Then if that does not help, I normally do not advocate shotgun replacement of components, BUT, in this case, considering the age and type of temp. compensating capacitors used, I will.

Replace the following:

C1 ----- 47pf 5% N30 ceramic.

C2,3 ----- 39pf 5% N150 ceramic.

C7,8 ----- 47pf 5% NPO ceramic.

C9 ----- 82pf 5% N80 ceramic.

C12 ----- 27pf 5% NPO ceramic.

C15 ----- 10pf 5% NPO ceramic

Note the physical placement of the capacitors in proximity to L1 and maintain that physical placement.

Be careful not to over-heat the new capacitors when replacing them.

VI-4, VFO TRACKING

Record the VFO frequency at the six dial settings in the chart below.

DIAL	SPEC FREQ	MEASURED
0	4.850	
100	4.750	
200	4.650	
300	4.550	
400	4.450	
500	4.350	

You may want to scan and make several copies of this chart

If at the 0 or the 500 index mark you are more than 1 KHz off, tracking of C4 and L1 is required. *The original manual spec at this point is 2 KHZ. But it is normally not difficult to get it less than 500 Hz. So why not try.* Adjust the tuning dial to the 500 and adjust L1 for 4.350 MHz. Adjust the dial to the 0 and adjust C4 for 4.850 MHz. You may have to repeat this several times to get it correct. Under correcting or overcorrecting at one end or the other is sometimes required to get it to fall in.

Rerun and record the data. If any of the mid points fall more than 2 KHz from spec, knifing of C5A,B is indicated (I used 1 KHz for my shop spec). **Knifing should never be attempted on the ha-20 unless you are very skilled at knifing.** C5 is fragile and can be **destroyed** very easily.

If you have a uniform distribution of the error, you can split the difference by adjusting C4. That is, move the end points half the max error in the opposite direction of the error.

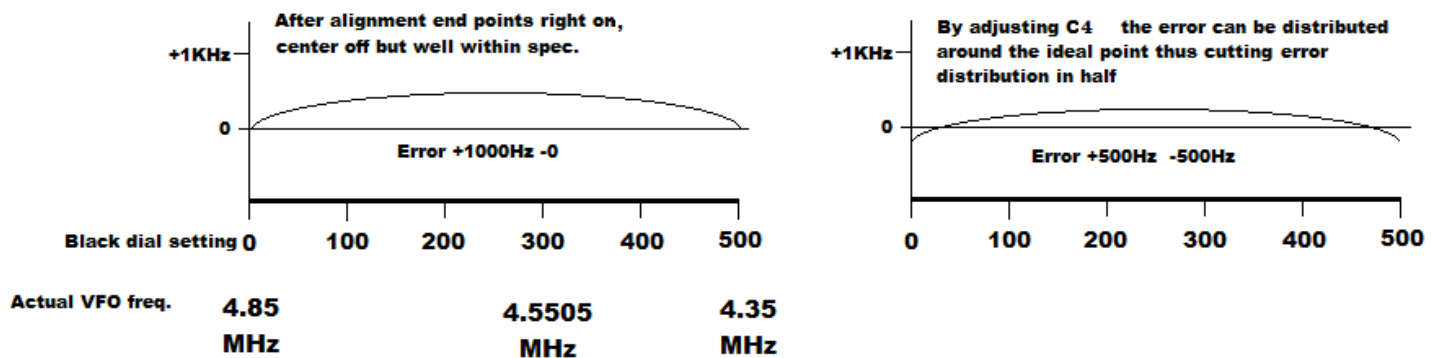

VII, VOLTAGE CHART

HA-20 VFO

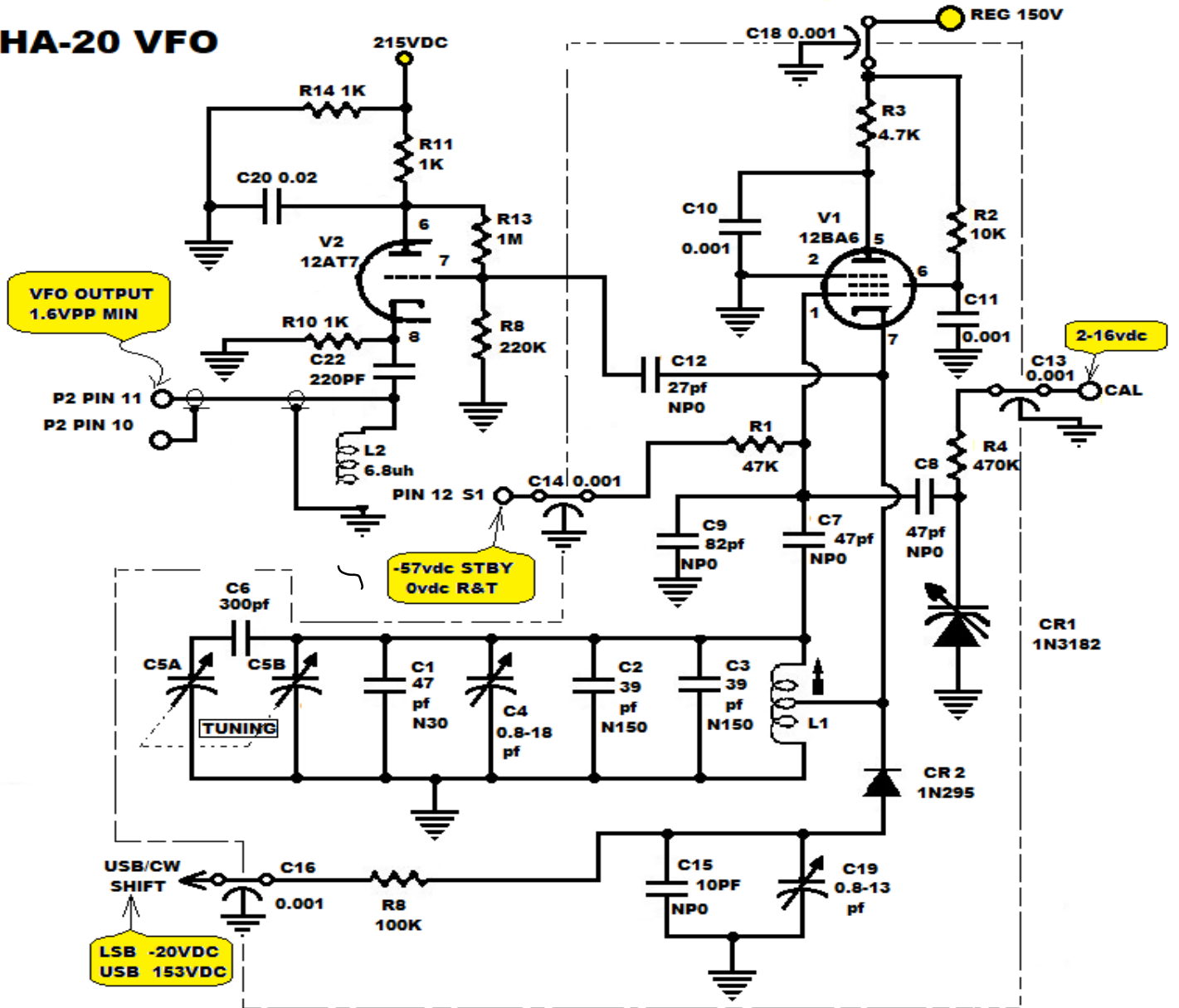

Measurements made in the R&T mode require a rf blocking probe (See APPENDIX 1).
The transceiver must be connected and set to the MOX mode.

	V1					/	V2		
PINS	1	2	5	6	7	/	6	7	8
STBY	-108vdc	gnd	150vdc	150vdc	0	/	206vdc	0	8vdc
R&T	-2vdc	gnd	108vdc	106vdc	0	/	206vdc	0	8vdc
						/			

APPENDIX

APPENDIX 1, RF BLOCKING PROBE

The inexpensive DVM's and VOM's work fine unless you are trying to measure a dc voltage with RF present, like the plate, grid or cathode of an oscillator or mixer. It is simple to make an RF blocking probe for an inexpensive meter. Install a 270uh to 1mh choke in the barrel of a dc probe. It will work with oscillators and low power mixers. Don't go messing about in the PA of a transmitter with one.

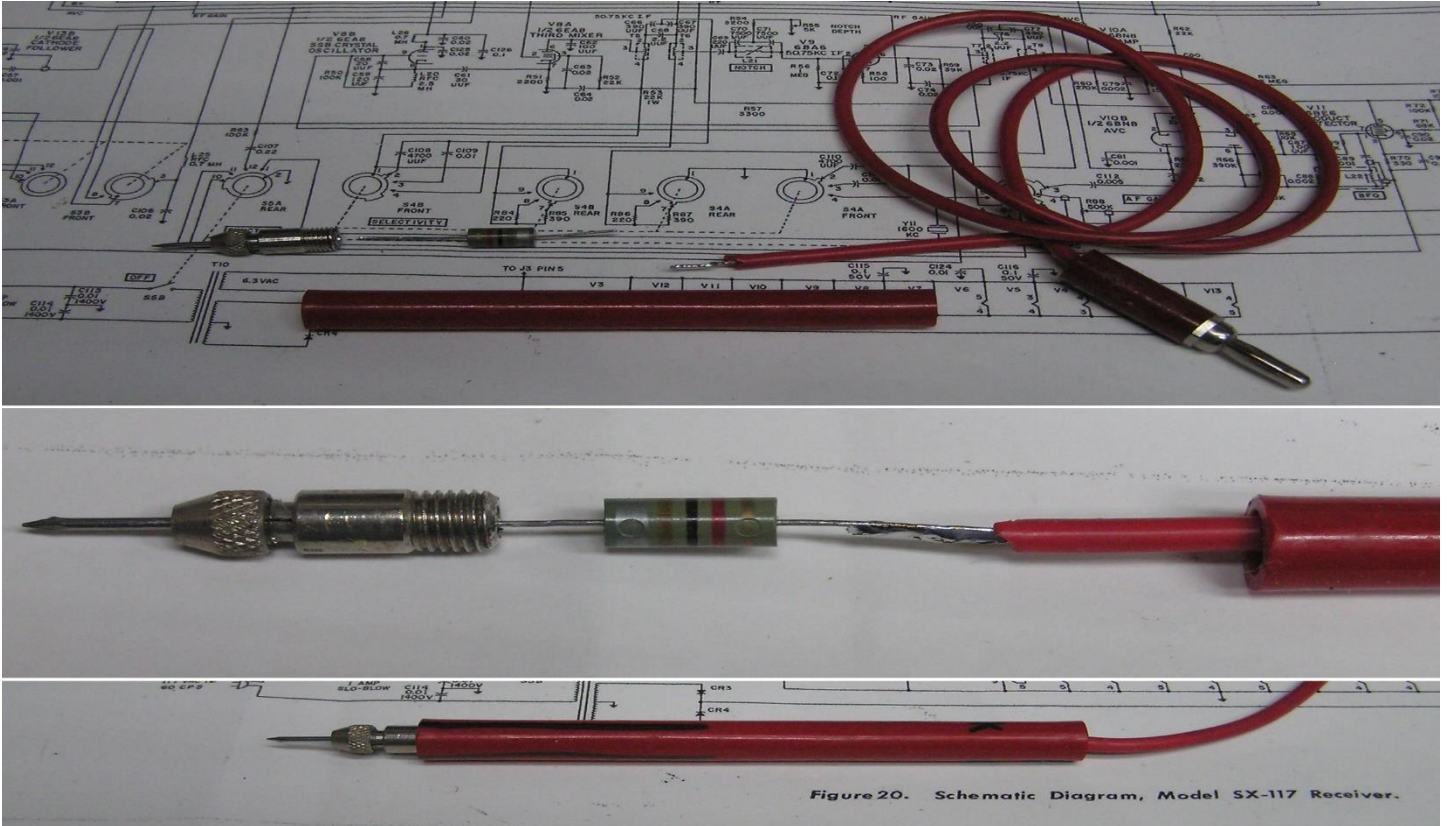

Figure 20. Schematic Diagram, Model SX-117 Receiver.

APPENDIX 2, TEST POINTS



