



OPERATING AND SERVICE INSTRUCTIONS

VARIABLE
FREQUENCY
OSCILLATOR
MODEL HA-26

WARRANTY

"The Hallicrafter's Company warrants each new radio product manufactured by it to be free from defective material and workmanship and agrees to remedy any such defect or to furnish a new part in exchange for any part of any unit of its manufacture which under normal installation, use and service discloses such defect, provided the unit is delivered by the owner to our authorized radio dealer, wholesaler, from whom purchased, or, authorized service center, intact, for examination, with all transportation charges prepaid within ninety days from the date of sale to original purchaser and provided that such examination discloses in our judgment that it is thus defective.

This warranty does not extend to any of our radio products which have been subjected to misuse, neglect, accident, incorrect wiring not our own, improper installation, or to use in violation of instructions furnished by us, nor extended to units which have been repaired or altered outside of our factory or authorized service center, nor to cases where the serial number thereof has been removed, defaced or changed, nor to accessories used therewith not of our own manufacture.

Any part of a unit approved for remedy or exchange hereunder will be remedied or exchanged by the authorized radio dealer or wholesaler without charge to the owner.

This warranty is in lieu of all other warranties expressed or implied and no representative or person is authorized to assume for us any other liability in connection with the sale of our radio products."

the hallicrafters co.

092-014907

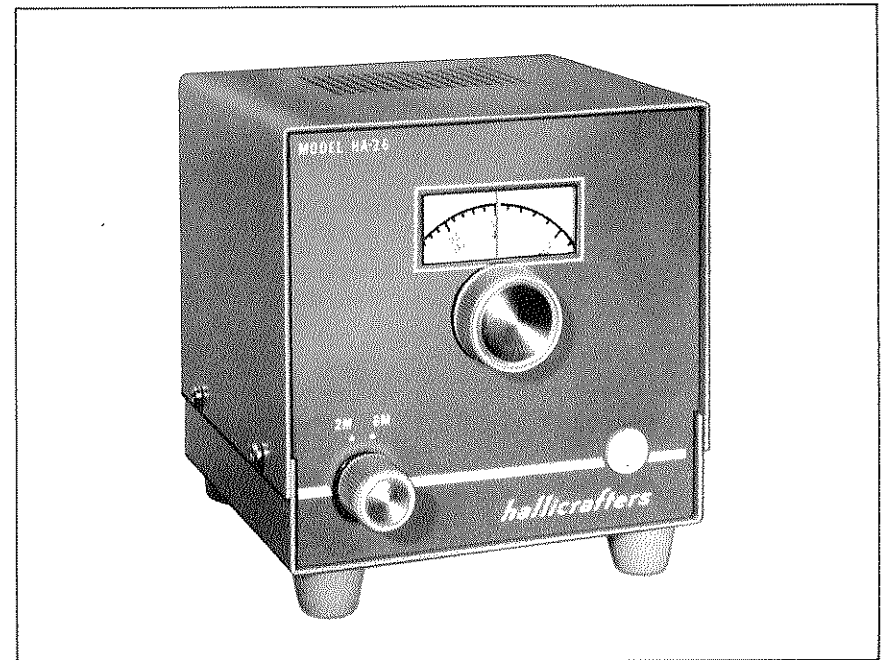

Figure 1. Hallicrafters Model HA-26 Variable Frequency Oscillator.

156-005530

SECTION I GENERAL DESCRIPTION

1-1. INTRODUCTION

The new Hallicrafters Model HA-26 is a compact, self contained, Variable Frequency Oscillator (VFO) designed as a transmitter crystal substitute for use with Hallicrafters Models SR-42 and SR-46 amateur band transceivers. The HA-26 may be used with these transceivers in base station installations where 117 volts 60 CPS is supplied, or in mobile installations where 12.6 VDC is available.

For ease and flexibility of operation, power from the SR-42 or SR-46 is supplied to the HA-26 via the combination power/output cable attached to the HA-26. When the companion transceiver is turned on power is automatically applied to the HA-26.

By means of a slide switch, located on the rear of the HA-26 chassis, 117V, 60 CPS or 12.6 VDC operation may be selected. The setting of this switch is dependent upon whether the companion transceiver is operated at 117V, 60 cycle or 12 VDC.

NOTE

A valid FCC license of the proper class is required by anyone operating this equipment on the air.

1-2. FEATURES

The HA-26 is a tickler coil type oscillator incorporating the following features:

- 12 volt DC or 117 volt AC operation.
- Zener regulated variable oscillator.
- Planetary drive for easier tuning.
- Pre-drilled cabinet mounting holes allowing the HA-26 to be mounted on the SR-42 or SR-46 during mobile operation.
- Easy to read, illuminated dial for night time operation.
- Temperature compensated oscillator.

SECTION II SPECIFICATIONS

TUBE	6U8A
OSCILLATOR FREQUENCY RANGE	2 Meters: 24.000-24.666 MC 6 Meters: 25.000-27.000 MC
OUTPUT LOAD	150 ohms (resistive)
RF OUTPUT	3 VRMS nominal (across 150 ohms)
STABILITY	Better than ± 3 KC of set oscillator frequency over a one hour period (after a 20 minute warm-up)
POWER SOURCE	SR-42 or SR-46 operating from either 105/125V, 60 CPS or 11/16 VDC (negative ground)
DIMENSIONS (HxWxD)	5-3/8 inches x 5-1/4 inches x 5-1/2 inches
NET WEIGHT	3 pounds
SHIPPING WEIGHT	4 pounds

SECTION III INSTALLATION

3.1. UNPACKING

After unpacking the HA-26, examine it closely for damage which may have occurred in transit. Should damage be apparent, immediately file a claim with the carrier stating the extent of the damage. Carefully check all shipping labels and tags for instructions before removing them.

3.2. LOCATION

The HA-26 is supplied with a 22-inch output/power cable. The unit should be located so that this cable is of adequate length to interconnect the VFO with the transceiver. When locating the VFO, avoid excessively warm locations such as those near radiators and heating vents. Also avoid direct blasts of air from circulating fans, etc. For proper ventilation do not place any object on the cabinet cover that will impair natural ventilation. Allow at least one inch clearance between the rear of the VFO and the wall. In mobile installations, avoid direct air blasts from heaters or air-conditioning units.

NOTE

The output/power cable distributed capacity is part of the resonating capacitance of the output stage. The length of this cable should not be varied if proper performance of the VFO is to be obtained.

3.3. CONNECTION TO TRANSCEIVER

The HA-26 power/output cable should be plugged into the VFO socket mounted on the rear chassis apron of the SR-42 or SR-46. The HA-26 may be used with these units when they are operated from either 117V, 60 CPS or 12 VDC, negative ground. When the HA-26 and its companion transceivers are to be run from a 12 VDC power source, a 10 Amp (Littlefuse Type 3AB) fuse should be placed in the fuse holder of the D.C. Power Cable Assembly.

In base installations where 117V, 60 CPS is used, the slide switch on the rear chassis apron of the HA-26 should be set to 117 VAC (figure 2).

In mobile or other locations where a 12 volt negative ground power source is used, the slide switch should be set to 12 VDC.

IMPORTANT NOTE

Failure to set the slide switch to the correct position will result in improper filament voltage which may cause a drastic reduction in driving power to the transceiver or a reduction in frequency stability when used in mobile operation.

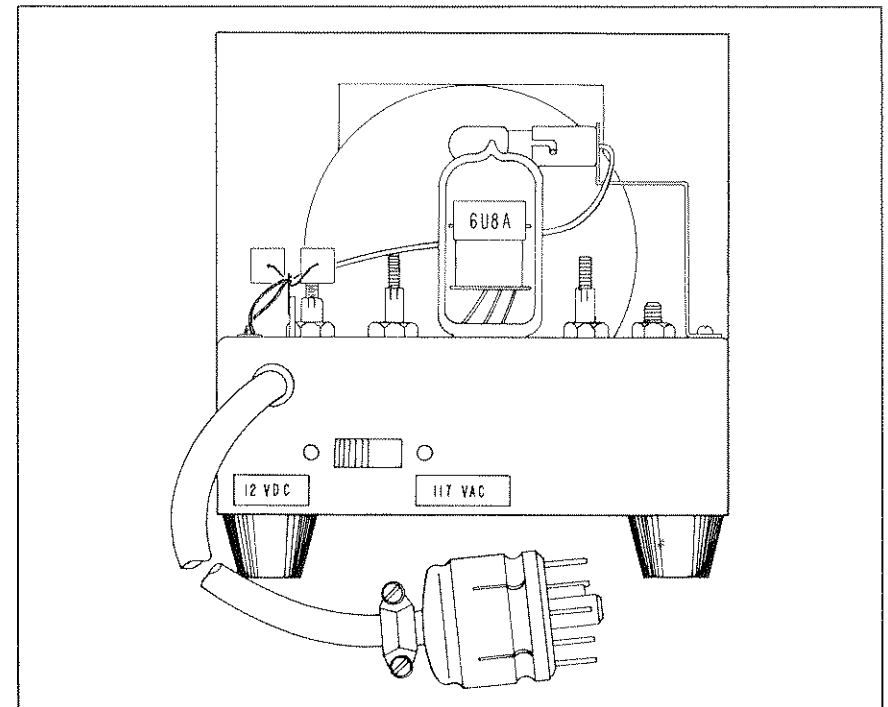

Figure 2. Rear View of VFO.

156-005510

The HA-26 and the companion transceivers are wired for 12 volt NEGATIVE ground operation, when used in mobile installations.

CAUTION

If it is desired to use the unit in vehicles having a 12 volt POSITIVE ground system the zener filament regulator CR2 must be insulated from the chassis and its connections reversed.

3-4. TYPICAL MOBILE INSTALLATION (Figure 3)

Four mounting holes have been pre-drilled in the HA-26 cabinet so that in mobile installations it may be mounted to the left of its companion transceiver with the furnished hardware. When the final mounting position has been determined, corresponding holes should be drilled in the side of the transceiver cabinet.

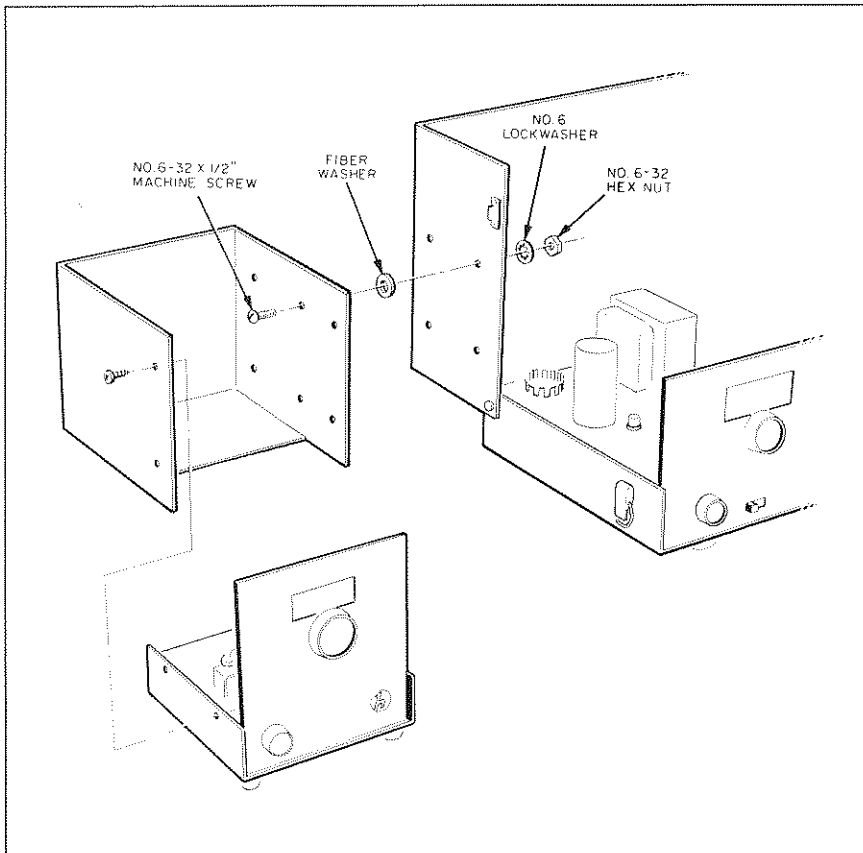

Figure 3. Typical Mobile Installation of VFO to Companion Transceiver.

156-0655-40

SECTION IV

FUNCTION OF OPERATING CONTROLS

4-1. GENERAL

Each control of the VFO performs a very definite function. Full appreciation of the VFO is to be expected only after becoming familiar with each of these controls. A brief description of each control is contained in the following paragraphs (see figure 4).

4-2. BAND SELECTOR CONTROL

The BAND SELECTOR control (marked 2M or 6M) is a two position rotary switch which selects the desired operating band; 2 meters (144-148 MC) or 6 meters (50-54 MC). It is located in the lower left hand corner of the front panel.

When used with the SR-42 the control should be set to 2M. In this position the lower or 144-148 MC dial calibrations should be used to indicate the frequency of operation. When used with the SR-46 the control should be set to 6M. In this position the upper or 50-54 MC dial calibrations should be used (figure 5).

IMPORTANT NOTE

It is imperative that the Band Selector Control be set to the correct position (2M when used with SR-42, 6M when used with SR-46) otherwise illegal off frequency operation will result.

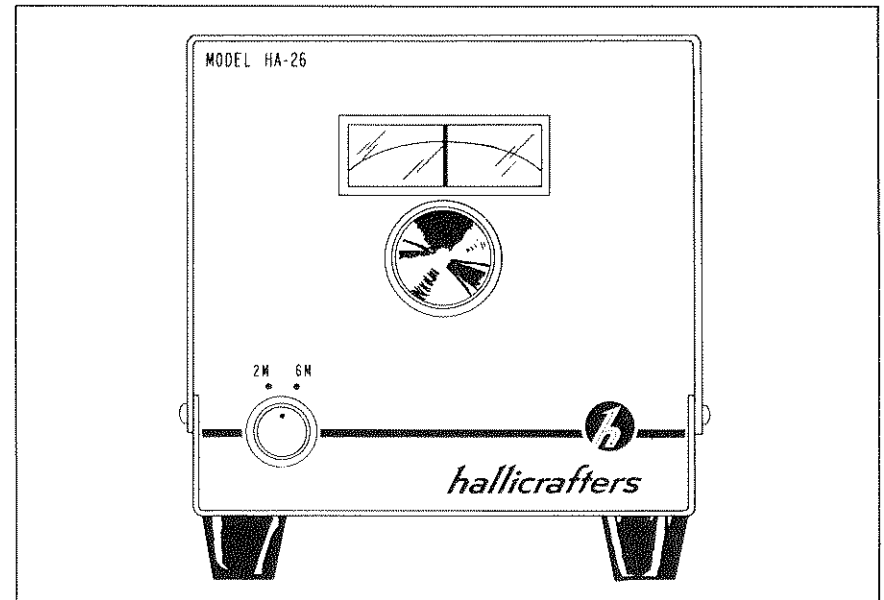

Figure 4. Front Panel View of VFO.

156-065509

4.3. TUNING CONTROL

The large unmarked knob is the TUNING control. This control rotates the dial and variable oscillator capacitor through a planetary drive system to provide the desired output frequency necessary to drive the transmitter in the SR-42 or SR-46.

4.4. 117 VAC - 12 VDC SLIDE SWITCH

The 117 VAC - 12 VDC slide switch is located on the rear apron of the HA-26 (figure 2). Its function is to switch a regulating zener diode and resistor combination into the filament circuit of the 6U8A VFO tube. This combination provides a constant 6.3 VDC filament voltage when operation from an 11 to 16 VDC source is desired. When the companion transceiver is operated at a nominal 12.6 VDC (negative ground), the switch must be in the 12 VDC (left hand) position. When the companion transceiver is to be operated at 117 VAC (normal house line voltage), the switch must be set to the 117 VAC (right hand) position. Improper operation will result if the switch is set to the wrong position.

SECTION V OPERATION

5.1. GENERAL

Set the 117 VAC - 12 VDC slide switch to the applicable voltage position. Set the band selector switch to the desired band (two meters as indicated by 2M or six meters as indicated by 6M). Turn on the transceiver and allow a few minutes warm-up before proceeding. Complete steps 1 and 2 in the transmitter tune-up procedure section of the SR-42 or SR-46 manual. Rotate transceiver XTAL-VFO switch to the VFO position. Preset GRID, PLATE and LOAD controls to mid-rotation (straight up). Tune the VFO to the desired frequency as indicated on the HA-26 calibrated dial. If desired, you may zero beat your receiving frequency by setting the transceiver FREQ SPOT switch to ON. Adjust the HA-26 tuning control for the maximum peak indication on the SR-42 or SR-46 output/S-meter. Refer to paragraph 4-3 of transceiver manual.

Due to the method of spotting used and the frequencies present it is possible to obtain several minor responses, indicated by up-scale deflections of the transceiver S-meter, when zeroing in on your receiving frequency. True zero beat however gives the greatest S-meter deflection and will be accompanied by quieting of the receiver. This frequency indicated on the HA-26 dial will match closely the indicated frequency of the receiver tuning dial. When this condition exists, the transmitting frequency coincides with the receiver frequency. Set the FREQ SPOT switch OFF. Now complete the remaining steps in the transmitter tune-up procedure described in the SR-42 or SR-46 instruction manuals, paragraph 4-3.

IMPORTANT NOTE

Do not attempt to operate near the band edges unless accurate frequency measuring instruments are available to insure that all of the transmitted signal is within the specified band limits.

5.2. DIAL SCALE

The HA-26 calibrated dial indicates the carrier frequency of the transmitter output stage NOT the VFO output frequency. The following table lists the amateur bands, the VFO output frequency, and the multiplication necessary to obtain the desired transmitter output frequency.

AMATEUR BAND	DIAL CALIBRATION	ACTUAL VFO OUTPUT FREQUENCY	MULTIPLICATION REQUIRED IN TRANSMITTER
6 Meters	50-54 MC	25.000-27.000 MC	X 2
2 Meters	144-148 MC	24.000-24.666 MC	X 6

The major dial calibrations for each band are 1 MC apart. Intermediate calibration marks are provided at 200 KC intervals for both bands (figure 5).

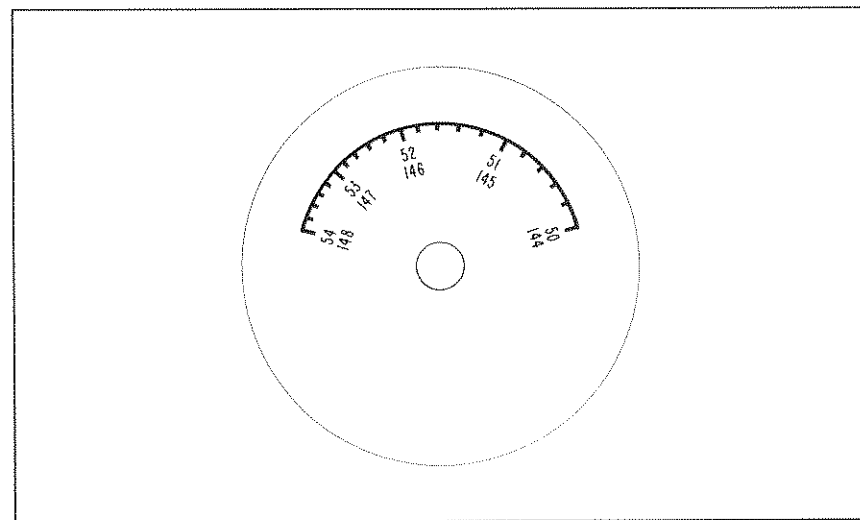

Figure 5. Dial Scale Calibrations.

156-005511

SECTION VI THEORY OF OPERATION

Tube V1A (1/2 6U8A) is a variable frequency oscillator tuning the range 25.000 - 27.000 MC for six meter operation and 24.000 - 24.666 MC for two meter operation. The parallel combination of C4, C6, C7, tuning capacitor C5 and coil L2 set the tuning range for the six meter band. For two meter coverage capacitors C1, C2, C3 and coil L1 are switched into the oscillator circuit while L2 is switched out. These values then determine the two meter band tuning range. C2, 3, 6, 7, 8 and 9 are temperature compensating capacitors that provide long term frequency stability.

The oscillator plate voltage is controlled by a zener regulator to maintain stable operation over a wide range of input voltage variations. In mobile operation the oscillator filament voltage is also zener regulated to compensate for the wide range in input voltage variations normally encountered under such conditions.

The pentode section of V1B acts as an amplifier-buffer between the oscillator and the transceiver. The VFO output coil (L3) along with the stray circuit capacity, capacitors C19, C12, and the capacity of the output/power cable comprises the circuit that is tuned to resonance in the range 25-27 MC for six meter operation. For two meter operation, C19 is shorted out and only C12 is used across the VFO output coil to lower its resonant frequency to the 24,000-24,666 MC range.

In the transmit mode, plate and screen voltages are applied to V1A and V1B. When the microphone push-to-talk button is released (transceiver now in receive) these voltages are removed. These voltages are also applied to the HA-26 VFO tube when the transceiver FREQ SPOT switch is set to ON. This enables zeroing the HA-26 to the receiver frequency without switching the transceiver into transmit.

SECTION VII SERVICE DATA

7-1. TUBE AND DIAL LAMP REPLACEMENT

To gain access to the tube and dial lamp, remove the chassis from the top cover of the cabinet (refer to paragraph 7-2). The location of the tube and dial lamp is shown in figure 6.

7-2. CABINET TOP COVER REMOVAL

To remove the VFO cabinet top cover from the chassis proceed as follows:

1. Disconnect power cable from SR-42 or SR-46.
2. Remove the four thread-forming screws on the side of the HA-26 cabinet.
3. Slide chassis top cover off.

7-3. CABINET BOTTOM PLATE REMOVAL

To remove the VFO cabinet bottom plate from the chassis proceed as follows:

1. Remove cabinet top cover (refer to paragraph 7-2).
2. Remove four screws on the bottom of the chassis that also secure the four mounting feet.
3. Slide the bottom cover off the chassis.

NOTE

Care should be exercised, when removing the chassis from the cabinet, so as not to damage any VFO components.

7-4. SERVICE AND OPERATING QUESTIONS

For further information regarding operation or servicing of this equipment contact the Hallicrafters dealer from whom it was purchased. The Hallicrafters Company maintains an extensive system of Authorized Service Centers where any required service will be performed promptly and efficiently at no charge if this equipment is delivered to the service center within 90 days from date of purchase by the original buyer and the defect falls within the terms of the warranty. It is necessary to present the bill of sale in order to establish warranty status. After the expiration of the warranty, repairs will be made for a nominal charge. All Hallicrafters authorized Service Centers display the sign shown at right. For the location of the one nearest you, consult your local telephone directory.



Service shipments should not be made to the factory unless instructed to do so by letter, as The Hallicrafters Company will not accept responsibility for unauthorized shipments. The Hallicrafters Company reserves the privilege of making revisions in current production of equipment and assumes no obligation to incorporate such revisions in earlier models.

SECTION VIII ALIGNMENT

8-1. GENERAL

The Model HA-26 VFO has been carefully aligned at the factory by specially trained personnel using precision equipment. Alignment of the VFO should not be required unless the VFO has been tampered with or component parts have been replaced. Alignment should only be performed by qualified personnel familiar with communications equipment and experienced in the alignment of such equipment.

8-2. EQUIPMENT AND TOOLS REQUIRED

1. Frequency measuring equipment such as a receiver capable of indicating frequency with an accuracy of at least 2 KC in the range 24,000 MC to 24,666 MC and 25,000 MC to 27,000 MC.

NOTE

If no other frequency indicating device is available refer to paragraph 8-5 for an alternate method of alignment, using the SR-42 or SR-46.

2. RF voltmeter.
3. Dummy load antenna (50 ohms resistive, 5 watts minimum rating).
4. Small screwdriver for adjustment of L1 and L2.
5. Slotted alignment tool for adjusting C1 and C4.
6. Non-metallic alignment tool (GC8606 or equivalent) for adjusting output coil slug.
7. Set-screw wrench (No. 6 Bristol).

8-3. SIX METER ALIGNMENT

1. Remove the top cover from the VFO (refer to paragraph 7-2).
2. Loosen the dial locking set screw and set tuning capacitor C5 so that its plates are fully meshed. Align the dial calibration mark with the red indicator line on the dial window and then tighten the dial set screw. (The dial calibration mark is the black dot to the right and down from the 50/144 MC mark on the dial.)
3. Set 117 VAC - 12 VDC switch to the proper position. Then plug the HA-26 output/power plug into the VFO socket on the transceiver.
4. Set Band Selector switch on HA-26 to 6M.
5. Set transceiver tuning controls to mid-range and connect dummy antenna.
6. Turn on transceiver power and allow at least fifteen minutes warm-up time before proceeding.
7. Set the receiver to CW reception at 25,000 MC.
8. Set transceiver FREQ SPOT switch to ON and XTAL-VFO switch to VFO.
9. Set the HA-26 tuning dial to the 50 MC calibration mark and adjust the six meter oscillator coil L2 to zero beat with the receiver at 25 MC.
10. Tune the receiver to 27,000 MC.
11. Set the HA-26 tuning dial to the 54 MC calibration mark and adjust oscillator trimmer capacitor, C4, to zero beat with the receiver at 27 MC.
12. Set the receiver back on 25,000 MC.
13. Set the HA-26 dial back to the 50 MC calibration mark and adjust L2 again for zero beat.

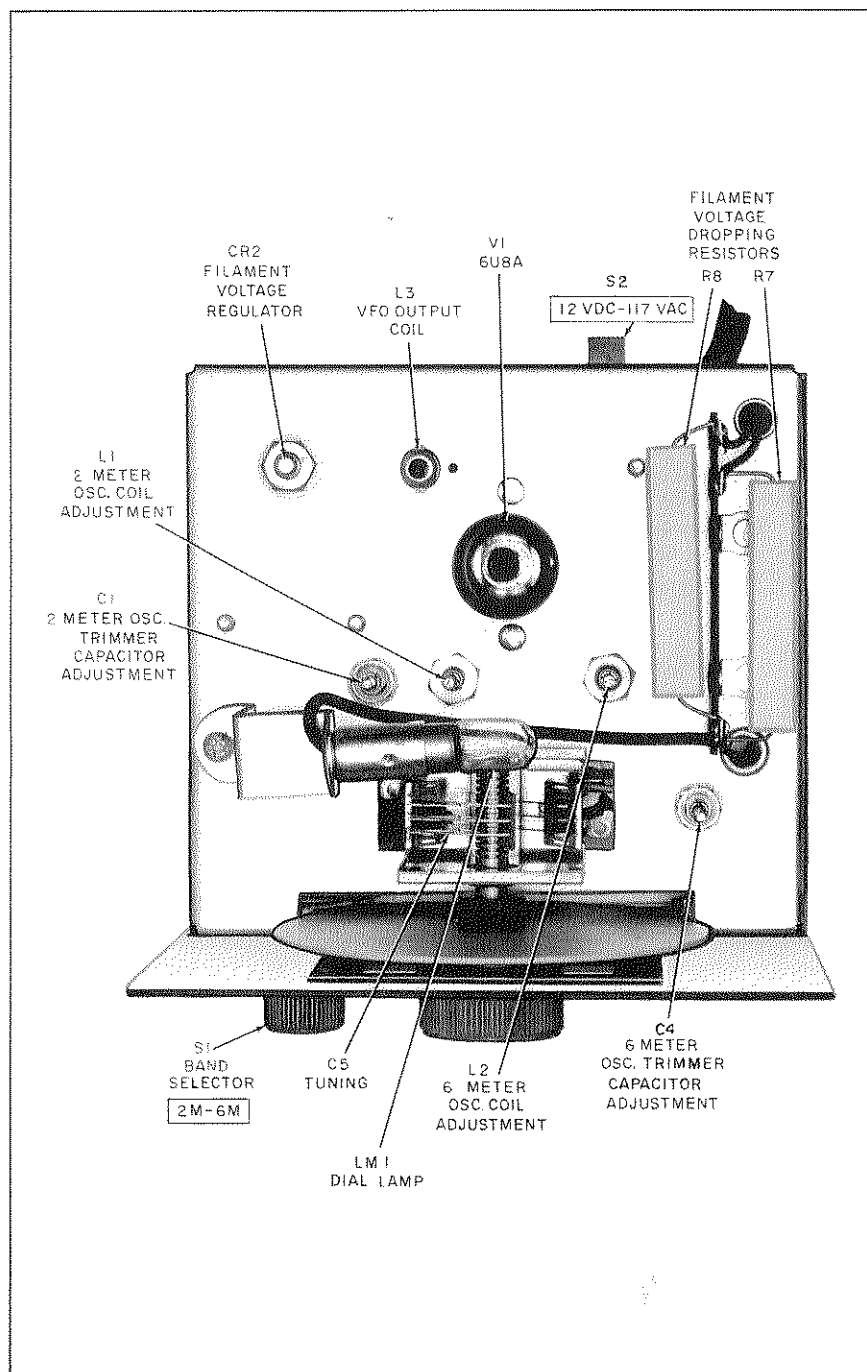

Figure 6. Top View of VFO Chassis.

156-005663

14. Repeat steps 7 thru 13 until both calibration points, 50 MC and 54 MC, on the VFO dial are aligned so that 50 MC zero beats with 25 MC on the receiver and 54 MC on the HA-26 dial zero beats with 27 MC on the receiver.

15. Set the HA-26 dial to approximately 52 MC. Adjust VFO output coil, L3, by turning the coil slug with the non-metallic alignment tool until maximum voltage is measured across the 150-ohm resistor connected to the transceiver VFO input socket (R41 on SR-42 and R36 on SR-46).

16. Set FREQ SPOT switch to OFF.

8.4. TWO METER ALIGNMENT

1. Perform steps 1-3 of six meter alignment.
2. Set Band Selector switch on HA-26 to 2M.
3. Perform steps 5 and 6 of six meter alignment.
4. Set the receiver to CW reception at 24,000 MC.
5. Set transceiver FREQ SPOT switch to ON.
6. Set the HA-26 tuning dial to the 144 MC calibration mark and adjust oscillator coil L1 to zero beat with the receiver at 24 MC.
7. Tune the receiver to 24,666 MC.
8. Set the HA-26 tuning dial to the 148 MC calibration mark and adjust oscillator trimmer capacitor, C1, to zero beat with 24,666 MC on the receiver.
9. Set the receiver back on 24,000 MC.
10. Set the HA-26 dial back to the 144 MC calibration mark and adjust L1 again for zero beat at 24,000 MC.
11. Repeat steps 7 thru 10 until both calibration points 144 MC and 148 MC on the VFO dial are aligned so that 144 MC zero beats with 24,000 MC on the receiver, and 148 MC on the HA-26 dial zero beats with 24,666 MC on the receiver.

NOTE

Because of a small amount of interaction between the six meter oscillator circuit and the two meter oscillator circuit, it will be necessary to re-check the six meter alignment and adjust coil L2 and capacitor C4 accordingly for precise dial calibration. Now the two meter calibration should be re-checked. Re-adjust C1 and L1 as necessary. When adjusting trimmer capacitors C1 and C4, do not overtighten slug as permanent damage to these units may result.

8.5. ALTERNATE TWO AND SIX METER ALIGNMENT

If no other frequency indicating device is available, the receiver portion of the SR-46 may be used for HA-26 six meter dial calibration. The receiver portion of the SR-42 may be used for HA-26 two meter dial calibration. When using either the SR-42 or SR-46, the transceiver FREQ SPOT switch must be used in conjunction with the S-meter. The HA-26 is to be tuned for maximum S-meter indication on the transceiver. Zero-beat the band-edges on the transceiver dial with the band-edges on the HA-26 dial by tuning the HA-26 for maximum S-meter indication while adjusting L2 and C4 for six meter operation, L1 and C1 for two meter operation. The band-edges on either transceiver may be accurately marked by obtaining transmitting crystals for the band-edge frequencies, and then spotting these frequencies by using the transceiver SPOT and XTAL-VFO switches. The crystal frequencies necessary are as follows: 25,000 MC and 27,000 MC for 6 meters, 24,000 MC and 24,666 MC for 2 meters.

Alternately, a short wave receiver, which is capable of tuning CW in the range 24,000 MC to 27,000 MC, may be used in conjunction with the above band-edge marker crystals and the SR-46 and SR-42 transceivers. The crystals are used in the transceivers to locate the band-edge frequencies on the short wave receiver dial. The HA-26 is then aligned by zero-beating these frequencies as described in paragraphs 8-3 and 8-4.

SERVICE REPAIR PARTS LIST

Schematic Symbol	Description	Hallicrafters Part Number
CAPACITORS		
C1,4	Variable, 1 PF to 8 PF, Trimmer	044-000593
C2	82 PF, 5%, 500 V, N30, Ceramic	491-025820-032
C3	56 PF, 5%, 500 V, N30, Ceramic	491-005560-032
C5	Variable, 5 PF to 14 PF	048-000570
C6	15 PF, 5%, 500 V, N220, Ceramic	491-005150-062
C7	25 PF, 5%, 500 V, N330, Ceramic	491-005250-073
C8	33 PF, 2%, 300V, Dura-mica	493-110330-323
C9	8 PF, ± 0.5 PF, 500 V, NPO Ceramic	491-002080-023
C10,11,13,14,18	0.01 μ F, $\pm 20\%$, 500 V, Ceramic Disc	047-100354
C12	1.5 PF, 2%, 300V, Dura-mica	493-140150-321
C15,16	0.02 μ F, $\pm 20\%$, 500 V, Ceramic Disc	047-100471
C17	0.1 μ F, +80 - 20%, 50 V, Ceramic Disc	047-001146
C19	5 PF, ± 0.5 PF, 300V, Dura-mica	493-110050-521
*RESISTORS		
R1,2	47 K ohm	451-252473
R3	330 ohm	451-252331
R5	1.5 K ohm	451-252152
R6	12 K ohm, 2 watts	451-652123
R7,8	15 ohm, 10 watts, Wire Wound	445-032150
R4	27 K ohm	451-252273
*All RESISTORS are carbon type, 1/2 watt, 10% unless otherwise specified.		
COILS		
L1	Coil, VFO (2 meter)	050-002021
L2	Coil, VFO (6 meter)	050-002022
L3	Coil, VFO Output	050-002023
TUBES AND DIODES		
V1	Tube, Electron, Type 6U8A	090-901285
CR1	Diode, Zener, Type VR120	019-003407
CR2	Diode, Zener	019-003461
MISCELLANEOUS		
	Cable Assembly	087-008332
	Clamp, Cable	076-202742
	Dial Assembly	150-008584
	Foot, Rubber	016-001076
	Foot, Rubber	016-002446
	Front Panel Assembly	150-008586
	Knob, Control	015-001843
	Knob, Control	015-001844
	Lamp, Pilot	039-100031
LM1	Plug, Octal Male	010-100239
P1	Socket, Pilot Lamp	086-000706
XV1	Socket, Tube (9-pin)	006-000947
S1	Switch, Rotary (Band Selector)	060-002729
S2	Switch, Slide, DPDT (117 VAC - 12 VDC)	060-002780
	Window, Dial	022-000725

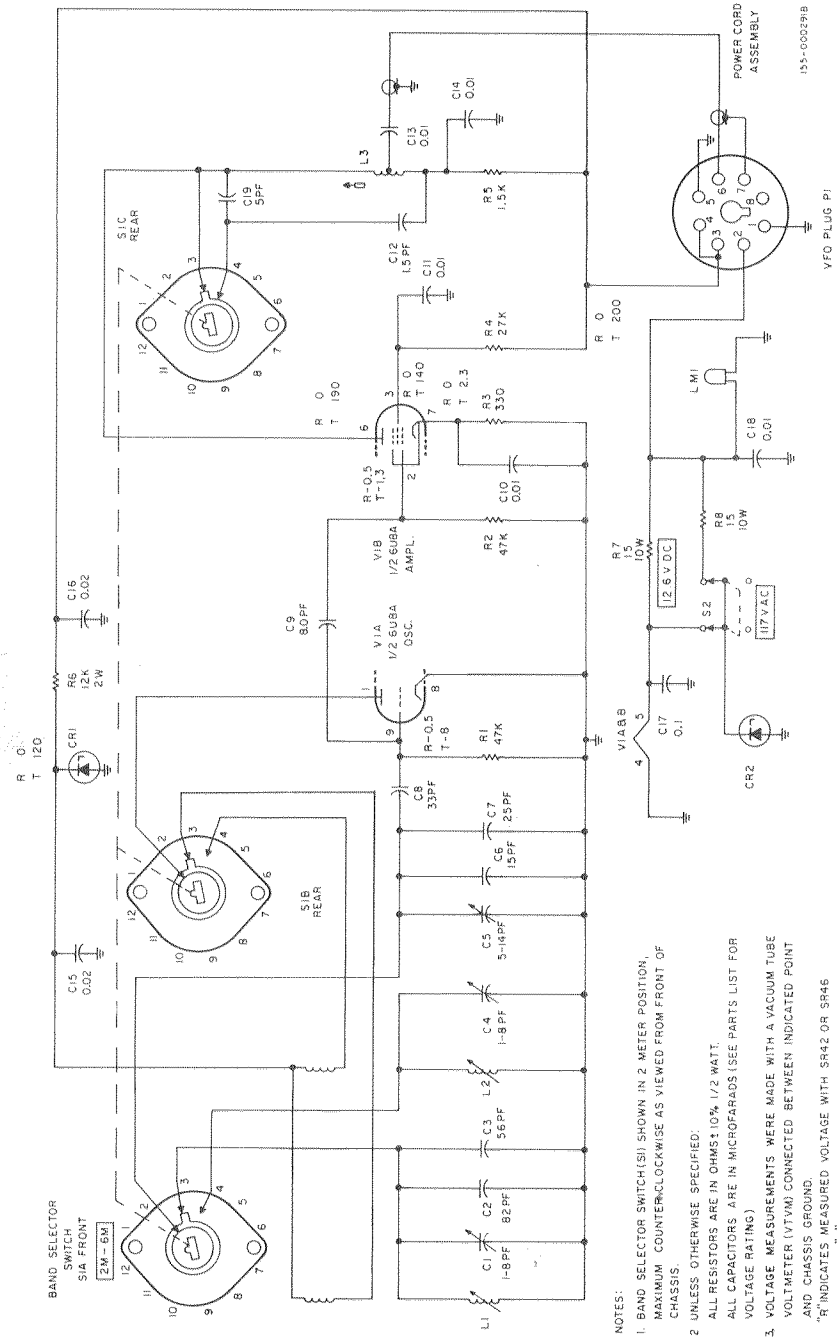

Figure 7. Schematic Diagram of Model HA-26 Variable Frequency Oscillator.