

DKB-2010

DUAL MODE KEYBOARD

**INSTRUCTION
MANUAL**



**HAL COMMUNICATIONS CORP.
BOX 365
URBANA, ILLINOIS 61801**

QUALITY COMMUNICATIONS EQUIPMENT

HAL DKB-2010 DUAL MODE KEYBOARD TECHNICAL MANUAL

WARRANTY

HAL Communications Corp. warrants that all factory-assembled DKB-2010 Dual Mode Keyboards shall be free of defects in materials and workmanship under normal use and service for a period of one year from the date of shipment, and further warrants that all parts supplied with DKB-2010 kits shall likewise be free of such defects for the same period.

In fulfillment of this warranty, HAL Communications Corp. will, at its option, repair or replace at no cost except for transportation expenses any factory-assembled keyboard (or, in the case of kits, any component) verified to be defective, provided that written notice of such defect is given during the warranty period.

Please do not return your keyboard or components to the factory until you have sent a letter of notification and have received a written return authorization.

This warranty is and shall be in lieu of all other warranties, whether expressed or implied, and of all other obligations or liabilities on the part of HAL Communications Corp. resulting from the installation or use of this keyboard.

The foregoing warranty is completely void for all keyboards and keyboard components which have been damaged, abused, modified, or improperly installed or operated.

Copyright © 1974 by HAL Communications Corp., Urbana, Illinois.
Printed in the U.S.A. All right reserved. Contents of this
publication may not be reproduced in any form without the
written permission of the copyright owner.

November, 1978 Printing
November, 2015 Reprint DC7XJ

NOTE: Inverted states – usually written for example as "HERE IS" – are shown in **blue** in this text.

TABLE OF CONTENTS

Specifications	4
Section I: General Information	
1.1 Description	6
1.2 Instrument Identification	6
1.3 Accessories Furnished	7
1.4 Manual Preview	7
Section II: Installation	
2.1 Initial Inspection	8
2.2 Preliminary Checkout	8
2.3 CW Transmitter Keying Connections	8
2.4 RTTY Loop Connections	10
2.5 Audio Output Connections	12
Section III: Operating your Keyboard	
3.1 Introducing	13
3.2 RTTY Operation	13
3.3 Morse Code Operation	15
Section IV: Theory of Operation	
4.1 Introducing	16
4.2 General Operating Principles	16
4.3 Circuit Analysis	17
4.4 Scanning Keyboard Encoder	19
4.5 ROM Code Converter	20
4.6 Storage Buffer	20
4.7 RTTY Control and Decoding Circuit	21
4.8 Shift Register and Control Circuit	22
4.9 RTTY Encoder and Loop Interface	25
4.10 RTTY Timing Chain	27
4.11 RTTY Character Counter	28
4.12 Morse Character Generator	28
4.13 Morse Output Control	31
4.14 Quick Brown Fox and ID Control	32
4.15 Identifier	33
4.16 Three-Character Sequencer	34
4.17 Power Supply	34
4.18 Character Codes	35
Section V: Assembly Instructions	40
Section VI: Maintenance	45
Section VII: Parts List	57
Section VIII: Diagrams	60

Extended Memory Option

1. Introduction	A1
2. Installation	A2
3. Operating Instructions	A3
4. Theory of Operation	A4
Schematic	A5
Key Buffer Timing	A6

ILLUSTRATIONS

Figure 2.1: Typical Connection for Cathode Keying	9
Figure 2.2: Typical Connection for Grid-Block Keying	10
Figure 2.3: Typical Loop Circuit Connection	10
Figure 2.4: Connection for Loop Circuit with Negative Lead Grounded	11
Figure 2.4a: Plug Preparation	11
Figure 2.5: Bridge Polarity Protection Circuit	12
Figure 3.1: Location of Controls and Keys	14
Figure 4.1: MM5740 Keyboard Encoder Integrated Circuit	18
Figure 4.2: Shift Register Waveforms for Transmission of the Letter "F"	24
Figure 4.3: Shift Register Control Signals for Morse Operation	25
Figure 4.4: Generation of the Letters-Shift Code	26
Figure 4.5: Generation of the Figures-Shift Code	26
Figure 4.6: Morse Clock and Decoder Waveforms	29
Figure 4.7: Production of Dots by the Morse Character Generator	29
Figure 4.8: Production of Dashes by the Morse Character Generator	30
Figure 4.9: Suppression of Dot at End of Character to Produce Intercharacter Space	31
Figure 4.10: Development of Clock Pulses for Automatic Character Sequencers	33
Figure 5.1a: Rear Panel Component Placement	
Figure 5.1b: Matching Transformer and Terminal Strip Details	
Figure 5.1c: Rear Panel Wiring	
Figure 5.1d: Wiring Detail for T301	
Figure 5.2: Installation of Power Cord Strain Relief	
Figure 5.3a: Top Panel Component Placement	
Figure 5.3b: Top Panel Wiring	
Figure 5.4: Wiring Harness Placement	
Figure 5.5: Assembly of Cabinet End Panels	
Figure 5.6: Space Bar mounting detail	
Figure 5.7: Integrated Circuit Orientation	
Figure 5.8: Mounting the MJE521 Power Transistor	
Figure 5.9: Capacitor Placement on Power Supply Board	
Figure 5.10: Jumper Placement on Logic Circuit Board	
Figure 5.11: Weight-Ratio Jumper Placement	
Figure 5.12: Bottom Cover Assembly	
Figure 5.13: Assembled DKB-2010 with Bottom Cover Removed	
Figure 5.14: Diode Placement in Identifier Matrix	44
Figure 6.1: Logic Circuit Board Test Points	50
Figure 6.2: Keyswitch Circuit Board Test Points	51
Figure 6.3: Power Supply Circuit Board Test Points	52

ILLUSTRATIONS (continued)

Figure 8.1: DKB-2010 Block Diagram	61
Figure 8.2: Drawing Conventions	62
Figure 8.3: Keyboard Encoder	63
Figure 8.4: ROM Code Converter and Buffer Control	65
Figure 8.5: RTTY Control and Decoder	67
Figure 8.6: Shift Register Control	69
Figure 8.7: RTTY Encoder and Loop Interface	71
Figure 8.8: RTTY Timing Chain	73
Figure 8.9: RTTY Character Counter	75
Figure 8.10: Morse Character Generator	77
Figure 8.11: Morse Output Control	79
Figure 8.12: Quick Brown Fox Generator and ID Control	81
Figure 8.13: Identifier	83
Figure 8.14: Three-Character Sequencers	85
Figure 8.15: Power Supply Module	87
Figure 8.16: Power Supply Board Component Layout	89
Figure 8.17: Keyboard Circuit Board Component Layout	90
Figure 8.18: Keytop Positions	91
Figure 8.19: Main Logic Board Component Layout - IC's	92
Figure 8.20: Main Logic Board Component Layout - Small Parts	93

TABLES

Table 3.1: Characters Produced by Bracketed Keys	13
Table 4.1: RTTY Timing Chain Output Frequencies	27
Table 4.2: ASCII Character Codes Used in the DKB-2010	36
Table 4.3: ROM Character Input and Output Code	37
Table 4.4: RTTY Baudot Codes	38
Table 4.5: Morse Codes	39
Table 5.1: Coding Chart for Identifier	41
Table 6.1: Test Points - Logic Circuit Board	49
Table 6.2: DKB Logic Board Connector (J305)	53
Table 6.3: DKB Keyboard Connector (J306) and DKB Power Supply (J307)	54
Table 6.4: DKB-2010 Wire List	55
Table 6.5: Integrated Circuit Pin Numbers for Ground And Power	56

DKB-2010 SPECIFICATIONS

<u>RTTY MODE</u>	
<p>Code: International Teletype, Baudot</p> <p>Character Format: 1 start bit (space) 5 data bits (mark or space) 1.5 stop bits (mark)</p> <p>The duration of each bit is one select time, determined by the transmission rate. The minimum stop bit length for Baudot code ranges from 1 to 1.46 bits, depending on transmission rate and application.</p> <p>Data Sense: Mark or "1": holding condition, output conducting. Space or "0": signaling condition, output nonconducting.</p> <p>Character Transmission Rates: 60 words per minute, 45.45 baud. Select time: 22 msec. 66 words per minute, 50.0 baud. Select time: 20 msec. 75 words per minute, 56.9 baud. Select time: 17.57 msec. 100 words per minute, 73.7 baud. Select time: 13.47 msec.</p> <p>Also available on special order: 132 words per minute, 100 baud Select time: 10 msec.</p> <p>Transmission Rate Accuracy: Crystal controlled to within $\pm .05$ % for ambient temperatures from 50 to 95 °F (10 to 35 °C).</p> <p>Output Interface: Isolated loop switching transistor. Ratings: Voltage, nonconducting: 250 V DC Current, conducting: 80 mA DC Isolation voltage rating: Either loop connection to chassis and ground 250 V AC or DC.</p> <p>Output Power Rating: 1 Watt.</p>	<p>RTTY Keyfunctions: 10 numeric (0 through 9) 26 alphabetic (A through Z) 15 punctuation marks: . , : ; / " - ! " # & \$ () '</p> <p>3 carriage control keys: linefeed carriage return, and blank 2 shift keys 1 break key 2 manual case-change keys 2 three-character memory keys (CQ and AUX) (repeating) Unless otherwise requested, AUX key transmits "DX" plus a space. 1 identifier key (HERE IS) (repeating) 1 test message key (QBF: "quick brown fox") (repeating) 1 space bar</p> <p>Identifier: Transmits the letters "DE" followed by the pre-programmed station call sign of up to 12 characters when the HERE IS key is struck. Message repeats as long as key is held down.</p> <p>Test Message Generator: Transmits the message "THE QUICK BROWN FOX JUMPS OVER THE LAZY DOG'S BACK Ø123456789" when the QBF key is struck. Repeats if key is held down.</p> <p>End-of-Line Warning: Panel lamp lights and audio tone burst is emitted if more than 64 printing characters are transmitted without an intervening carriage return.</p> <p>Character Buffer Memory: Stores up to three characters if typing speed exceeds character transmission rate. Panel lamp warns when memory is full. Optional 64 and 128 character buffers are available.</p> <p>N-Key Rollover: New key may be pressed before the preceding key is released.</p> <p>Automatic Case Shift: Numbers may be transmitted without use of the shift key; case shift codes are transmitted automatically.</p>

DKB-2010 SPECIFICATIONS (continued)

<p style="text-align: center;"><u>Morse Mode</u></p> <p>Code: International Morse</p> <p>Data Sense: Keyed: output conducting Space: output nonconducting</p> <p>Character Transmission Rate: Continuously adjustable from less than 8 to greater than 60 words per minute.</p> <p>Character Weight: Any of six weight ratios from 1:7 to 3:1 may be chosen. A panel switch permits selection of the four standard weights: Heavy (5:3), normal (1:1), light (3:5), and very light (1:7). The switch wiring may be altered to substitute ratios of 1:3 and 3:1 in place of one or two of the standard weights.</p> <p>Note: Character weight is the ratio of dot duration to the length of the space between adjacent dots or dashes. For the normal weight ratio of 1:1, the ratio of dot and dash lengths is 1:3. For other weights, dash duration is equal to the length of two dots plus the duration of one space between consecutive dots or dashes.</p> <p>Output Interface: Transmitter keying transistor may be used for either cathode or gridblock keying (but not both simultaneously).</p> <p>Transistor ratings: Cathode keying: Voltage, nonconducting: +250 V DC Current, conducting: 150 mA DC Grid-block keying: Voltage, nonconducting: -150 V DC Current, conducting: -150 mA DC</p> <p>Output power rating: 1 Watt</p>	<p>Morse Keyfunctions: 10 numeric (0 through 9) 26 alphabetic (A through Z) 9 punctuation marks: . , : ; / " - ' () 5 special character keys: (SK, AS, AR, KN, BT) 2 shift keys 1 break (tune) key 1 error key (8 dots) 2 three-character memory keys: (CQ and AUX) 1 identifier key (HERE IS) 1 space bar</p> <p>All RTTY-only keys produce the Morse error signal.</p> <p>Sidetone Oscillator: Internal speaker emits audio tone keyed in synchronism with output keying transistor. Volume adjustable by panel control. Pitch adjustable by internal control.</p> <p>Identifier: Performs same function as in RTTY mode.</p> <p>Character Buffer Memory: Performs same function as in RTTY mode.</p> <p>N-Key Rollover: Performs same function as in RTTY mode.</p> <p>General: Size: 13.5" wide, 5" high, 9" deep (34.3 × 12.7 × 22.9 cm) Weight: 5 lbs. (2.27 kg.)</p> <p>Power: 105 - 125 V AC, 47 to 440 Hz, 1/8 amp. (Optional 220 - 250 V AC, 1/16 amp).</p> <p>Operating Temperature: 50 to 95 °F (10 to 35 °C).</p>
---	--

I. GENERAL INFORMATION

1.1 Description

The HAL DKB-2010 is a solid-state, electronic keyboard designed for transmitting both RTTY (Baudot) and Morse codes. A successor to HAL Communication's popular first-generation keyboards, the DKB-2010 provides many advanced operating features:

1. A three-character buffer memory stores the characters typed for transmission at a constant rate. Coupled with the n-key rollover capability, it helps iron out variations in typing speed and style.
2. A station identifier, included as standard equipment, automatically transmits the station call sign at the touch of a key.
3. The four RTTY operating speeds (60, 66, 75, and 100 words per minute) are switch selectable and, to assure stability, crystal controlled. The Morse speed is continuously variable from 8 to 60 words per minute.
4. A warning light and tone signal the RTTY operator when line length exceeds 64 characters.
5. A built-in RTTY test generator automatically transmits a standard test message ("THE QUICK BROWN FOX JUMPS OVER THE LAZY DOG'S BACK 0123456789") at a single keystroke.
6. The Morse code weight can be set to any of four ratios by a frontpanel switch. Weight is unaffected by changes in speed.
7. The space bar functions in the Morse mode to simplify interword spacing.
8. Two "memory" keys can be preprogrammed to automatically transmit three-letter combinations. One is normally used to transmit "CQ", followed by a space. The code for the other (the AUX key) is selected by the owner at the time of purchase; if not specified it is coded to transmit "DX" followed by a space.

For the RTTY operator, the DKB-2010 provides automatic transmission of the case-shift code when typing numbers and letters; the shift key is needed only for certain punctuation marks. The loop switching transistor in the keyboard output stage is completely isolated from chassis and ground so that it may be connected at any convenient point in the station loop circuit.

For Morse operation, a sidetone oscillator with adjustable pitch and volume simplifies monitoring of the transmitted code. Five double-character keys (SK, AS, AR, KN, and BT), along with an error key (which transmits eight dots), provide the special characters needed in Morse work. A tune key overrides the keyboard output and keys the transmitter on for adjustment. Keying is accomplished by a high-voltage switching transistor, which may be connected for either cathode or grid-block keying.

The keyboard circuitry is constructed on three G-10 glass-epoxy circuit boards, housed in an attractive yet rugged two-tone gray cabinet. The circuit boards are interconnected by a factory-prepared wiring harness to simplify construction and servicing. Output connections are conveniently located on the rear panel. The internal power supply incorporates active, series-pass regulators to ensure stability.

1.2 Instrument Identification

Your keyboard is identified by a serial number tag on the rear panel. It is suggested that you record it in the space provided on the title page of this manual. Please refer to the serial number when contacting the factory for information or service.

1.3 Accessories Furnished

The DKB-2010 is shipped with the following accessories:

- 2 6-contact plugs
- 2 3-contact plugs
- 18 female connector pins
- 1 phono plug
- 2 lengths, 2 conductor shielded cable
- 1 operating and service manual

1.4 Manual Preview

This manual is provided to help you get the most from your keyboard, whether you have selected the factory-wired or the kit model. In the following sections, you will find instructions for installing and operating the DKB-2010. Please read them carefully before attempting to use your keyboard.

Section 4 provides a full description of the keyboard circuitry. Step-by-step instructions for constructing the keyboard kit will be found in Section 5; testing and maintenance are covered in Section 6. Parts lists and a complete set of schematic diagrams are bound at the rear of the manual in Sections 7 and 8 for ease of reference.

~~FOR KIT-BUILDING INSTRUCTIONS, TURN TO PAGE 5-1.~~

II. INSTALLATION

2.1 Initial Inspection

When you unpack your DKB-2010 keyboard, examine it carefully. If evidence of shipping damage is found, contact the carrier immediately. Before discarding the packing material, check that all parts and accessories are accounted for (included accessories are listed in Section 1.3). If any are missing, please notify the factory in writing.

If your keyboard is in kit form, check the parts against the list in Section 7 of this manual. Then turn to Section 5 for assembly instructions.

2.2 Preliminary Checkout

Connect the power cord to an AC source of the proper voltage and frequency.

NOTE: The keyboard can be connected for either 105 to 125 volt or 210 to 250 volt operation. Factory-assembled units are wired for nominal 115 volt input unless otherwise indicated by a tag attached to the power cord. Before connecting the power cord, be certain that the voltage of the outlet corresponds to the keyboard input voltage rating.

To ensure operator safety, connect the power cord to a three-prong outlet with safety ground. DO NOT attempt to defeat the grounding prong of the keyboard cordset. To do so will void the warranty.

Next, rotate the mode switch to the Morse position. Switch the keyboard on by rotating the volume control clockwise to about the center of its range. When power is first applied, the identifier and the three-character memory circuits may be in their active states. If so, the stored characters will be clocked out of the memory in rapid succession. Wait until the process is complete. Then press any of the letter or number keys. The keyboard should produce a keyed audio tone corresponding to the Morse code pattern of dots and dashes for the character. Test several other keys, adjusting the speed, volume, and weight controls to check their operation. If this preliminary test is satisfactory, the keyboard is ready to be connected to your CW transmitter and RTTY loop circuit.

If the keyboard will be used for both RTTY and Morse operation in your station, prepare the connecting cables described in Sections 2.3 and 2.4. The keyboard may be left connected to both the RTTY loop and the CW transmitter; it is not necessary to exchange cables or remove plugs when changing modes, as the RTTY and Morse output stages of the keyboard are completely independent. Of course, the keyboard need not be used for both modes. In that case, simply prepare cables for the appropriate output Jacks and leave the others unconnected.

BEFORE PROCEEDING WITH THE INSTALLATION, DISCONNECT THE AC POWER CORD.

2.3 CW Transmitter Keying Connections

The keyboard Morse output stage is a high-voltage switching transistor. When connected to the transmitter, this electronic switch takes the place of the normal hand key. The keyboard may be connected for either cathode or grid-block keying (but not both at the same time), depending on which of the two rear-panel keying jacks is used. The two Morse output connections may not be used at the same time. The Morse output control circuitry is shown in Figure No. 8.11.

Before attempting to connect the keyboard to the transmitter keying terminals, examine the transmitter circuit diagram carefully to determine the keying method used. The keyboard cannot be used with "floating" key circuits; one of the two keying terminals must be grounded within the transmitter.

The transistor keying switch is rated to withstand 250 volts at up to 150 mA in cathode keying service. For grid-block keying, the voltage at the key should not exceed -150 volts, and the current should not be greater than 150 mA. Before connecting the keyboard, measure the voltage across the keying terminals of the transmitter with the key open and the current through the key when it is closed to ensure that these ratings are not exceeded.

Some transmitters (such as the Yaesu FTDX-560 and several of the Swan transceivers) include a wave-shaping filter in the key line, with a capacitor connected directly across the key terminals. The charge stored in this capacitor can produce a current surge large enough to damage the keyboard switching transistor when the transmitter is keyed. If such a capacitor is present in your transmitter, a resistance of between 100 and 390 ohms must be inserted in series with the line to the keyboard. Use a ½ Watt resistor, choosing the highest value in this range that does not degrade transmitter performance. The resistor can be mounted on the plug used to connect to the keyboard output jack.

CAUTION: HIGH VOLTAGES MAY BE PRESENT AT THE TRANSMITTER KEYING TERMINALS. UNPLUG THE TRANSMITTER AND THE KEYBOARD BEFORE MAKING THE FOLLOWING CONNECTIONS.

For cathode keying, the keyboard output switch is connected in series with the cathode circuit of the keyed transmitter stage. A typical installation is illustrated in Figure 2.1. Use a length of shielded wire to connect from the transmitter to the keyboard Morse Output jack. Hook the center conductor to the cathode of the keyed stage. Ground the shield at the transmitter. Install a plug on the other end of the cable, connecting the center conductor to pin 3 and the shield braid to pin 2. Connect a jumper wire between pins 1 and 3 of the plug. Prepare the plug connections as shown in Figure 2.4A. Insert the plug into the Morse Output jack on the rear panel of the keyboard.

A typical arrangement for grid-block keying is shown in Figure 2.2. In this circuit, the transistor switch shorts the negative grid blocking voltage to ground when the transmitter is to be keyed. As in the case of cathode keying, a shielded cable should be used to interconnect the transmitter and keyboard. At the transmitter end, connect the center conductor to the normal keying point in the bias circuit. Ground the shield. At the other end of the cable, install a plug with the center conductor of the cable connected to pin 1 and the shield to pin 2. Connect a jumper between pins 2 and 3 of the plug. Prepare the plug connections as shown in Figure 2.4A. Insert the plug into the Morse output jack on the rear panel of the keyboard.

CAUTION: POTENTIALLY LETHAL VOLTAGES MAY BE PRESENT AT THE PLUG CONTACTS WHEN THE TRANSMITTER IS TURNED ON. DO NOT DISCONNECT THE KEYING CABLE FROM THE KEYBOARD WITHOUT FIRST SWITCHING THE TRANSMITTER OFF.

Once the keying cable has been prepared and the plug inserted into the proper keyboard jack, set the mode switch to Morse and switch the keyboard on. Allow time for the identifier memory to clear itself; then press any of the letter or number keys. The audio sidetone oscillator should produce the correct sequence of dots and dashes for the character, and the transmitter should key simultaneously.

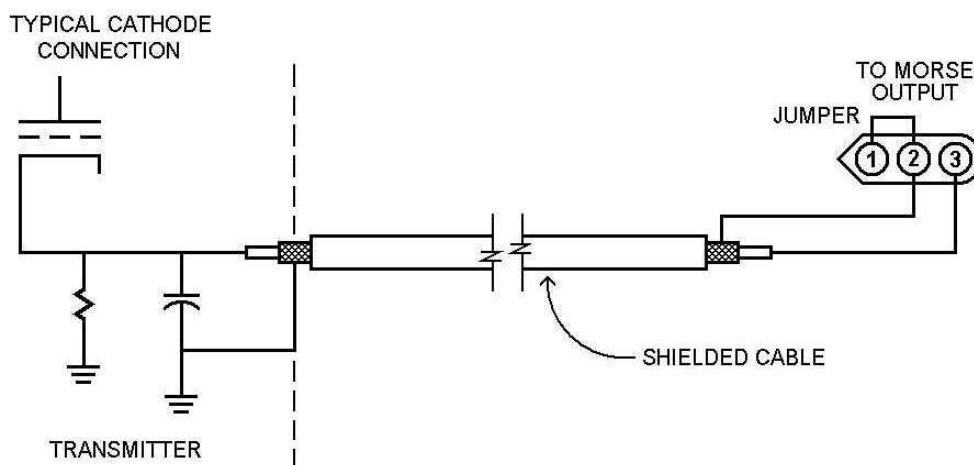

Figure 2.1 Typical Connection for Cathode Keying

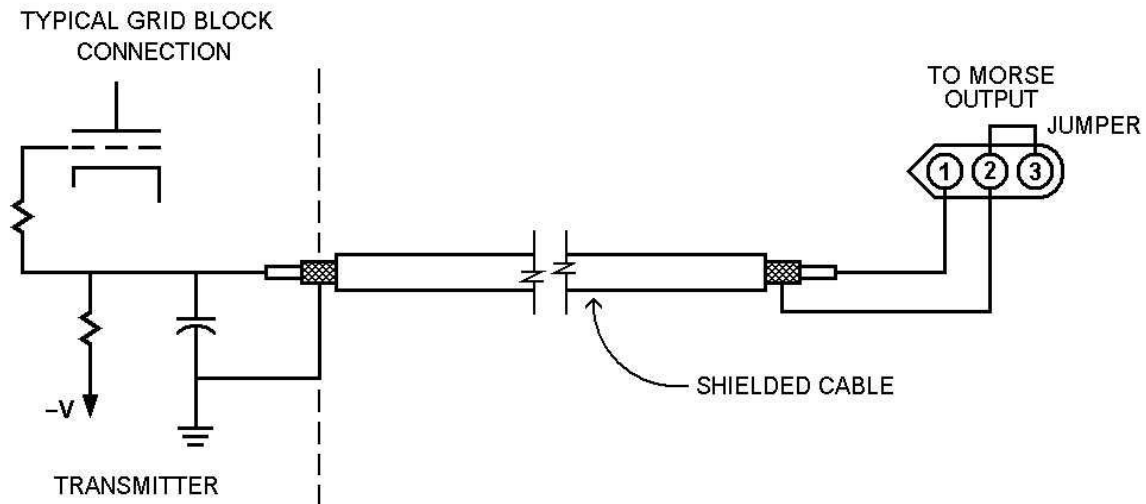

Figure 2.2 Typical Connection for Grid Block Keying

2.4 RTTY Loop Connections

Since the RTTY output stage of the keyboard is isolated from ground and from the chassis, the keyboard can be connected at any convenient point in the station loop circuit, provided that the voltage from either loop connection to ground does not exceed 250 volts. Loop current is switched by a transistor, rated to carry up to 80 mA DC and to withstand loop voltages up to 250 volts DC. Before making any connections to the keyboard, measure the loop voltage in the space condition and the current during mark pulses to make certain that neither exceeds the keyboard ratings.

UNPLUG THE KEYBOARD AND THE STATION LOOP SUPPLY BEFORE TAKING ANY CONNECTIONS.

A typical station loop circuit is shown in Figure 2.3. A 6 pin plug is used to connect the loop to the keyboard. Break the loop circuit at the desired point and connect the positive lead to pin 1 of the plug. Connect the negative lead to pin 3. The cable shield, if one is used, may be connected to pin 2. A jumper (or additional RTTY equipment) should be connected between pins 4 and 6. Double check the polarity of the loop leads, as reverse voltages may damage the switching transistor. Then insert the plug into the RTTY LOOP jack on the keyboard rear panel.

If the negative loop keying lead is grounded, the connections shown in Figure 2.4 should be used. Prepare the plug connections as shown in Figure 2.4A.

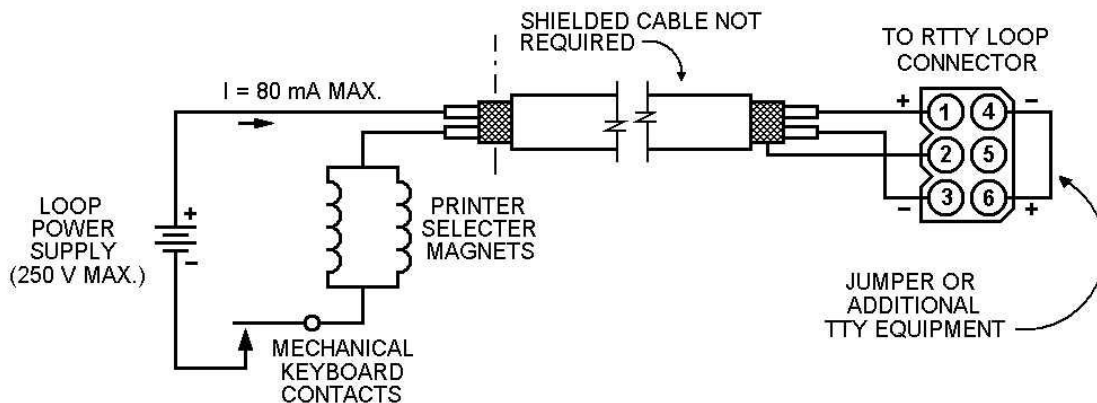
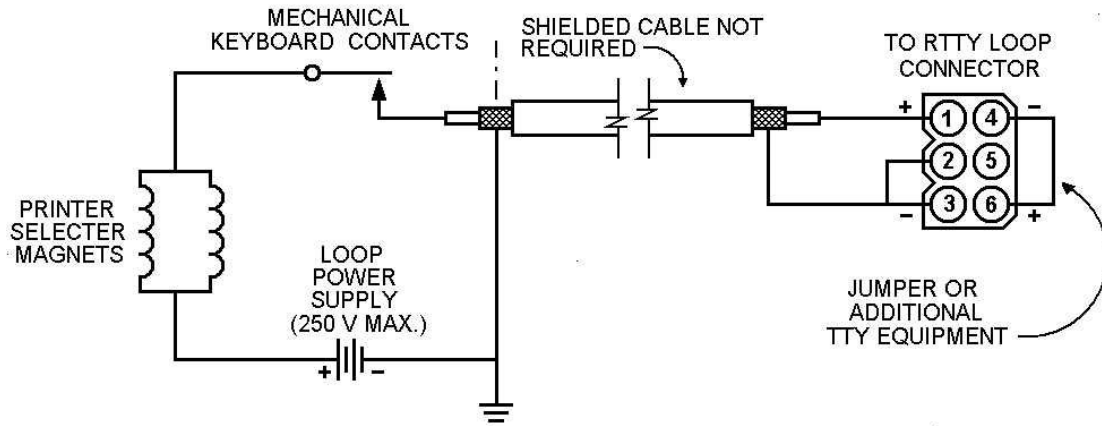

Figure 2.3 Typical Loop Circuit Connection



NOTE: DO NOT USE CATHODE AND GRID BLOCK AT SAME TIME

Figure 2.4 Connection for Loop Circuit with Negative Lead Grounded

The diode bridge circuit shown in Figure 2.5, if installed at the RTTY LOOP plug, makes it possible to connect the loop leads without regard for polarity. Diode polarity must be carefully observed when constructing the circuit, and the leads must be properly insulated and positioned so that they do not short together. This circuit is not recommended for loops operating at less than 30 volts, as the diodes may introduce too much voltage drop. The bridge arrangement may be used even if one lead of the loop circuit is grounded.

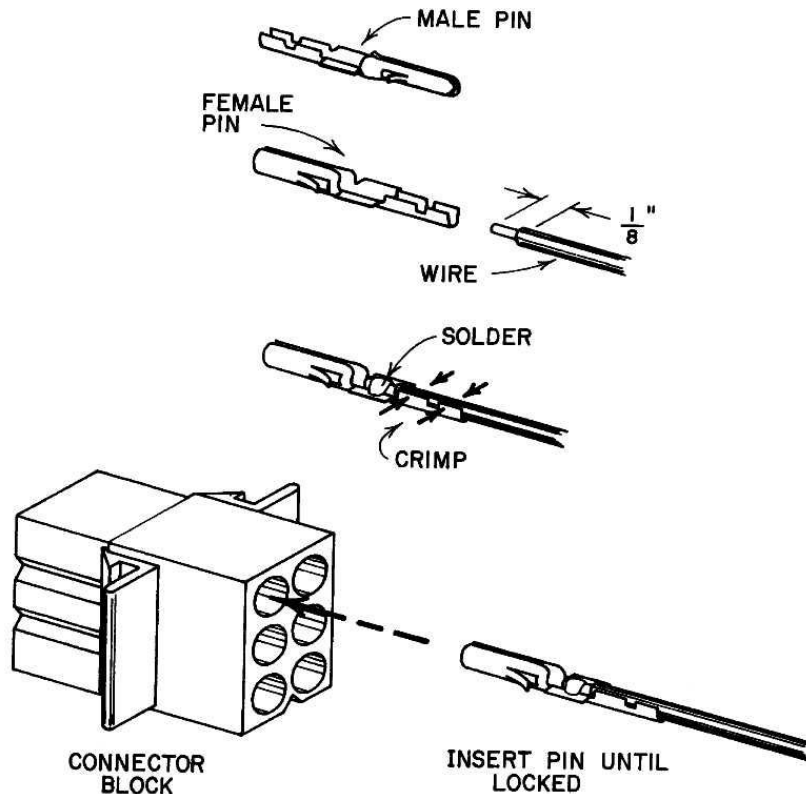

Figure 2.4a Plug Preparation

CAUTION: LOOP SUPPLY VOLTAGES ARE EXPOSED AT THE CONTACTS ON THE PLUG. IF YOU USE A HIGH VOLTAGE LOOP SUPPLY, DO NOT SWITCH IT ON UNLESS THE PLUG IS INSERTED INTO THE KEYBOARD RTTY LOOP JACK.

Once the connections have been made and the plug inserted, the loop supply and keyboard may be plugged in and switched on. With a printer or visual display unit connected into the circuit, set the mode switch to the correct speed and press any of the character keys. The printer should reproduce the character. If the printer is in letters case, pressing a letter key followed by a number key should shift it to figures case. Typing another letter should return it to letters case. After 64 printing characters have been typed without an intervening carriage return, the END OF LINE lamp will light and the speaker will emit an audio tone burst.

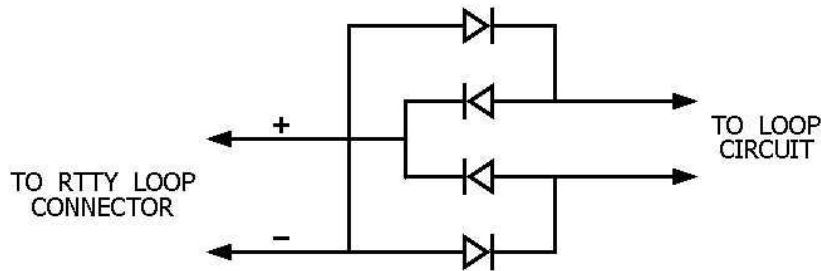

Figure 2.5 Bridge Polarity Protection Circuit

2.5 Audio Output Connections

The audio signal from the sidetone oscillator may be coupled to an external circuit via the AUDIO OUT jack. Solder the center conductor of a shielded cable to the pin of a phone plug, and connect the braid to the plug shell. Insert the plug into the output jack. The amplitude of the audio signal may be adjusted with the keyboard volume control.

III. OPERATING YOUR KEYBOARD

3.1 Introduction

The many advanced features of the DKB-2010 keyboard make it easy to produce flawless RTTY and Morse code signals. The operating tips presented in this section will help you take full advantage of your keyboard's capabilities, RTTY operation will be covered first. Since most features are operative in both modes, Morse operation is very similar. The few differences are explained in Section 2.3. Figure 3.1 shows the position of the keys and controls.

3.2 RTTY Operation

Switch the keyboard on by rotating the volume control clockwise to about the middle of its range. The quick brown fox and identifier circuits may be active when power is applied. If so, they will complete their sequences and clear themselves in ten seconds or less. Since it is possible for both circuits to start in the active state, the output during this period may be unintelligible. When the sequence is complete, set the mode control to the desired RTTY operating speed, and turn on the station loop supply and printer.

To transmit any character, simply press the corresponding key. It is not necessary to depress one of the SHIFT keys before typing numbers, as the keyboard will produce the required figures-case code automatically before transmitting the number. Likewise, the next time you strike one of the letter keys, the letters-case code will be sent. The most common punctuation marks (period, comma, colon, semicolon, and fraction bar) can also be typed without using the SHIFT key.

Some punctuation marks appear on the upper half of their keytops. To type these characters, press either of the two SHIFT keys and hold it down while you strike the desired key. Then release the SHIFT key.

Five of the keys are inscribed with two characters joined by brackets. The characters these keys produce change when the keyboard is switched from RTTY to Morse operation. The keys and their functions are listed in Table 3.1.

In the RTTY mode, the character shown on the lower half of the key is transmitted if neither of the SHIFT keys is depressed when the character key is struck. If, on the other hand, a SHIFT key is held down while the colon key is struck, the bell code will be transmitted. The hyphen and semicolon keys produce blanks in the shifted mode. The carriage return and linefeed keys transmit the same character regardless of the shift key position.

Unless you are a very proficient typist, you probably will not be able to type characters faster than the keyboard can transmit them. If you type in short, rapid bursts, however, you may find that you can momentarily "get ahead" of the keyboard – that is, you may strike a new key before the code for the preceding one has been transmitted in its entirety. The three-character buffer memory and n-key rollover features of the DKB-2010 help to compensate for these typing speed variations.

Table 3.1: Characters Produced by Bracketed Keys

Key	RTTY Mode		Morse Mode	
	Unshifted	Shifted	Unshifted	Shifted
Bell :	Colon	Bell	\overline{SK}	Colon
AS -	Hyphen	Blank	\overline{AS}	Hyphen
BT ;	Semicolon	Blank	\overline{BT}	Semicolon
AR LF	Line Feed	Line Feed	\overline{AR}	\overline{AR}
KN RETURN	Carriage Return	Carriage Return	\overline{KN}	\overline{KN}



Figure 3.1 Location of Controls and Keys

As soon as you type the first character of a series, the keyboard will begin transmitting it. You may then type two more characters, even though transmission of the first one has not been completed. The keyboard will "remember" characters and transmit them in the proper sequence. To help you pace your typing, the MEMORY FULL lamp will light when three characters have been stored. Simply wait until the light goes out, indicating that there is room for another character in the memory, before your next keystroke. If you should happen to press another key while the memory light is on, the last character in the memory will be replaced with the new one typed.

The n-key rollover feature means that you do not have to release a key before striking the next one. The keyboard will transmit the characters in the proper order.

Another operating convenience of the keyboard is the Line length indicator. If you type more than 64 consecutive printing characters, the END OF LINE lamp will light and an audio tone will be emitted as a reminder to send a carriage return and linefeed. Non-printing characters, such as Linefeeds and blanks, are not counted as part of the 64 characters, This warning feature is particularly useful when you are punching paper tape.

Five standard RTTY control keys are provided. The LINEFEED, RETURN (carriage return), and BLANK keys perform their normal functions of advancing the printer paper one line, returning the carriage to the left margin, and punching blank characters on paper tape, respectively. Although the keyboard produces all required figures-case and letters-case codes automatically, a figures (FIGS) key and letters (LTRS) key are provided so that you may manually shift the case of the receiving teleprinter. It is not necessary to use these keys when transmitting characters which appear on the upper half of the keytops. Instead, use one of the SHIFT keys as described previously. The keyboard will automatically transmit the figures-case code, and will also return the printer to letters case the next time a letter key is struck.

The keyboard includes a number of special keys which simplify RTTY operation by automatically transmitting strings of several characters at a single keystroke. The key labeled QBF produces the standard RTTY test signal: "THE QUICK BROWN FOX JUMPS OVER THE LAZY DOG'S BACK Ø123456789". It is not necessary to hold the key down once the message has started. If, however, the key is held down through the end of the sequence, the entire message will be repeated.

A station identifier, actuated by the HERE IS key, is preprogrammed to transmit the letters "DE", followed by your station call sign. The sequence will be repeated as long as the key is held down.

The CQ key produces the letters "CQ" followed by a space. Another special key, labeled AUX (for auxiliary) can be preprogrammed to transmit any group of three characters. On factory-assembled keyboards, this key is programmed with the characters requested by the purchaser when the keyboard was ordered. If not specified, it is programmed to produce the letters "DX" followed by a space. Kit builders may select the characters at the time of construction. Both keys repeat their character sequence if held down.

The last of the special keys is the BREAK key. In its idling state (when no characters are being transmitted), the keyboard loop switching transistor conducts. Hence, the loop circuit is in the mark condition. For testing, the current may be interrupted, changing the loop to the space condition, by depressing the BREAK key. Releasing the key returns the loop switch to normal operation.

When the keyboard power switch is turned off, the station loop will be interrupted, since no current can flow in the loop switching transistor. If you wish to use other equipment connected in the loop, the circuit may be completed by either switching the keyboard on and allowing it to idle, or by setting the MODE switch to the Morse position. In the latter case, one section of the MODE switch bridges across the output transistor, allowing loop current to flow.

3.3 Morse Code Operation

Morse codotyping with the DKB-2010 keyboard is very similar to RTTY operation. Set the MODE switch to the Morse position and rotate the volume control clockwise to switch the keyboard on. Allow a few seconds for the identifier circuit to clear itself. Set the WEIGHT control to Norm. Touch any letter key and adjust the VOLUME control for the desired audio sidetone level. The SPEED control may be adjusted for any code speed from 8 to 60 words per minute.

The MEMORY FULL lamp and the n-key rollover features work the same as in the RTTY mode to help you pace your typing. Since Morse transmissions do not involved a fixed line length, the END OF LINE warning light is not operative. However, it may light if the MODE switch is set to the Morse position when the keyboard power is switched on. To extinguish the lamp, move the MODE switch to any of the RTTY positions and press the return key. Then return the switch to the Morse setting.

The HERE IS, CQ, and AUX keys operate in their normal manner, but the RTTY test generator (QBF key) is inappropriate for Morse transmission and therefore does not function. The BLANK key produces the standard eight-dot Morse error signal.

Five "double character" keys ([SK], [AS], [AR], [KN] and [BT]) are available exclusively in the Morse mode. Each of these appears on the upper portion of the key, but is enclosed by square brackets indicating that it is not necessary to press a SHIFT key when transmitting the character. If, however, you strike the SK, AS or BT keys while holding one of the shift keys down, the punctuation marks shown on the lower half of the key will be produced, as shown in Table 3.1. The AR and KN keys produce the same output regardless of the SHIFT key position.

Only 10 of the punctuation marks are used for Morse code (. , / ; ? - () and '). Of these, the last seven are transmitted using the SHIFT key. Attempting to transmit any of the remaining punctuation marks produces the Morse error signal

The space bar performs its normal function to ensure proper spacing between words. You will find it particularly useful when you type fast enough to store more than one character at a time in the keyboard memory.

The BREAK key operates in the Morse mode, but has a different effect than in RTTY operation. When pressed, it closes the electronic keying switch, holding the transmitter on the air for tuning and adjustment. Releasing the key returns the keying circuit to normal operation.

The WEIGHT control offers a choice of four weight ratios, varying from very light (1:7) to heavy (5:3). In Morse code, the Weight is the ratio of the length of a dot to the length of the space between dots and dashes. At the very light setting, the dots will sound very short. As the switch is moved toward the heavier weight ratios, the dots will sound longer when compared to the spaces between dots and dashes. Experiment with the setting until you find the one that seems the most pleasing.

The volume control adjusts the sidetone oscillator output level. The pitch may be changed, if necessary, by an internal adjustment, described in Section VI.

IV. THEORY OF OPERATION

4.1 Introduction

This section describes the circuitry of the DKB-2010 keyboard system and explains its operation, first in general terms and then in detail.

A block diagram of the system is provided in Figure 8.1, bound in Section 8 with the schematic diagrams of the keyboard circuitry. The drawing symbols and conventions used are illustrated in Figure 8.2.

The keyboard uses integrated digital logic circuitry throughout. Readers unfamiliar with the principles of logic circuits may find it helpful to refer to an introductory discussion of The subject before proceeding ¹.

4.2 General Operating Principles

The primary function of the keyboard circuits is to convert the closure of a keyswitch into a series of sequential pulses-marks and spaces in the RTTY mode, or dots and dashes in the Morse mode. These pulses appear at the keyboard output stages, where they activate switching transistors to key the station loop circuit or CW transmitter.

Of the 53 independent keyswitches, 46 are arranged in a matrix. The remaining seven are used for special functions. The 46 matrix keys are connected to a large-scale integrated-circuit keyencoder. Whenever this circuit senses closure of a keyswitch, it produces a seven-bit digital code, which appears in parallel form at the circuit's output. This code is the ASCII equivalent ² of the character to be transmitted.

Some of the keyswitches can produce two different characters. One of these characters is printed on the lower half of the keytop. Those appearing on the upper half are "shifted" characters, transmitted by pressing one of the shift keys along with the character key. Closure of the shift keyswitch instructs the keyencoder to produce the ASCII code for the shifted rather than the unshifted character.

Of the seven keys not connected to the matrix, two are the shift keys just mentioned. Four others are used to initiate special character sequences: the station identifier message, the "quick brown fox" test signal, and the special three-character memory sequences. The remaining key, labeled BREAK, allows the operator to break the RTTY loop manually, or, in the Morse mode, to key the transmitter manually for tuning.

The ASCII code produced by the keyencoder or one of the special message generators must be converted to a different pattern of bits to produce the RTTY or Morse code pulse sequence. The conversion is accomplished by a read only memory (ROM) preprogrammed with the code patterns required for each character. The seven-bit code from the keyencoder or the special message generators, along with an eighth bit which selects the RTTY or Morse mode, is applied to the eight address inputs of the ROM. The input code addresses a particular eight-bit location in the memory. In that location is stored the correct code for the character, which appears at the ROM output. Thus the ASCII code is converted to the Morse or RTTY bit pattern.

The ROM output is fed to an eight-bit buffer memory. If the keyboard is idle, the code is passed directly to the 10-bit static shift register. If the latter register already contains a character, however, the buffer stores the code until the shift register is cleared and ready to accept new input data.

Up to this point, all character codes are handled in parallel format (all bits are transmitted simultaneously on parallel lines). Both the Morse and RTTY transmission modes, however, require that the output pulses appear sequentially. The 10-bit shift register performs the necessary parallel-to-serial conversion. The input code bits from the storage buffer are loaded into the shift register in parallel. Clock pulses are then applied to the register, causing the bits to appear in sequence at the register output.

¹ One useful reference is the text by Thomas P. Sifferlen and Vartan Vartanian, Digital Electronics with Engineering Applications (Englewood Cliffs, N. J.: Prentice Hall, Inc., 1970).

² The ASCII code is the American Standard Code for Information Interchange, widely used in data processing systems. Table 4.2 in Section 4 lists the ASCII code for each character used in the DKB-2010 keyboard.

Depending on the setting of the mode switch, the register output activates either the Morse character generator or the RTTY loop switching circuit. In the RTTY mode, the output code keys the loop switch through an isolation circuit. For Morse transmission, the bits must be converted to pulses of unequal length, forming dots and dashes. The Morse character generator accepts the serial code from the shift register and performs the conversion. The generator output activates the Morse keying transistor and the sidetone oscillator.

Several additional circuits are included to increase operating convenience. In the RTTY mode, a counter keeps track of the number of characters transmitted after a carriage return. It activates the RTTY END OF LINE lamp and triggers a toneburst from the sidetone oscillator when 64 characters have been produced.

The "quick brown fox" generator produces the standard RTTY test message when the QBF key is pressed. A similar automatic character sequencer, usable in both the RTTY and Morse modes, produces the letters DE and the station call sign whenever the operator strikes the HERE IS key. Two other automatic sequencers produce three-character groups at a single keystroke. One is normally coded to transmit the letters CQ followed by a space. The other, activated by the AUX key, may be programmed for any group of three characters of the user's choice by rearranging diodes in a memory matrix. All of the sequencers will repeat their messages as long as the activating keyswitch is held down.

4.3 Circuit Analysis

In the following sections, the keyboard circuitry will be described in greater detail. In the course of the discussion, frequent reference is made to the schematic diagrams included in Section 8. Figure 8.2, which precedes the schematics, illustrates the drawing conventions used.

To aid in tracing signal paths through the keyboard circuit diagrams, each line which connects between portions of the circuit shown on different drawings is designated by a name that describes its function (e.g., BUFFER FULL). Some of the labels are overscored, indicating that the signal carried by the line is inverted or "negative true". Thus the BUFFER FULL line is at its "high" level (above 2.4 Volt) when a character has been stored in the buffer register. On the other hand, the line designated RTTY TONE activates the tone generator when it changes to its "low" state (less than 0.8 Volt).

To aid in locating the source of the signals on these lines, a code is included with the name, except, of course, at the point where the signal originates. The code consists of a number and a dash, followed by a letter and number pair (for example, 8.1-B3). The first number indicates the figure in which the signal source may be found – in this case Figure 8.1. Each schematic diagram includes coordinates, similar to those used on maps, along two of its edges. The letter-number pair of the code gives the coordinates of the area on the drawing where the signal originates. In the case of the code 8.1-B3, the signal source may be found in Section B3 of Figure 8.1.

Two signal lines which deserve special attention are the M/R line and its inverted counterpart, the M/R line. The signal on these buses switches the keyboard between the Morse and the RTTY mode, disabling the RTTY circuits when the mode switch is set to the Morse position, and the Morse circuits when it is set to one of the RTTY operating speeds, the M/R bus is high in the Morse mode and low in the RTTY mode; the M/R line assumes the opposite states.

Most of the keyboard circuit components and wiring are contained on two printed circuit boards. The boards are interconnected by a wiring harness with a card-edge connector at each end. The harness also connects to the cabinet-mounted components and to the power supply. Small squares containing a single letter or number appear on some signal lines to indicate that the line is connected to the harness through one of the edge connectors. The number or letter in the square corresponds to the connector pin designation.

The keyboard encoder is included on the circuit board to which the key-switches are mounted. All other circuitry, except for cabinet mounted parts, is found on the other boards. A wire list of the harness connections is included at the end of Section 8.

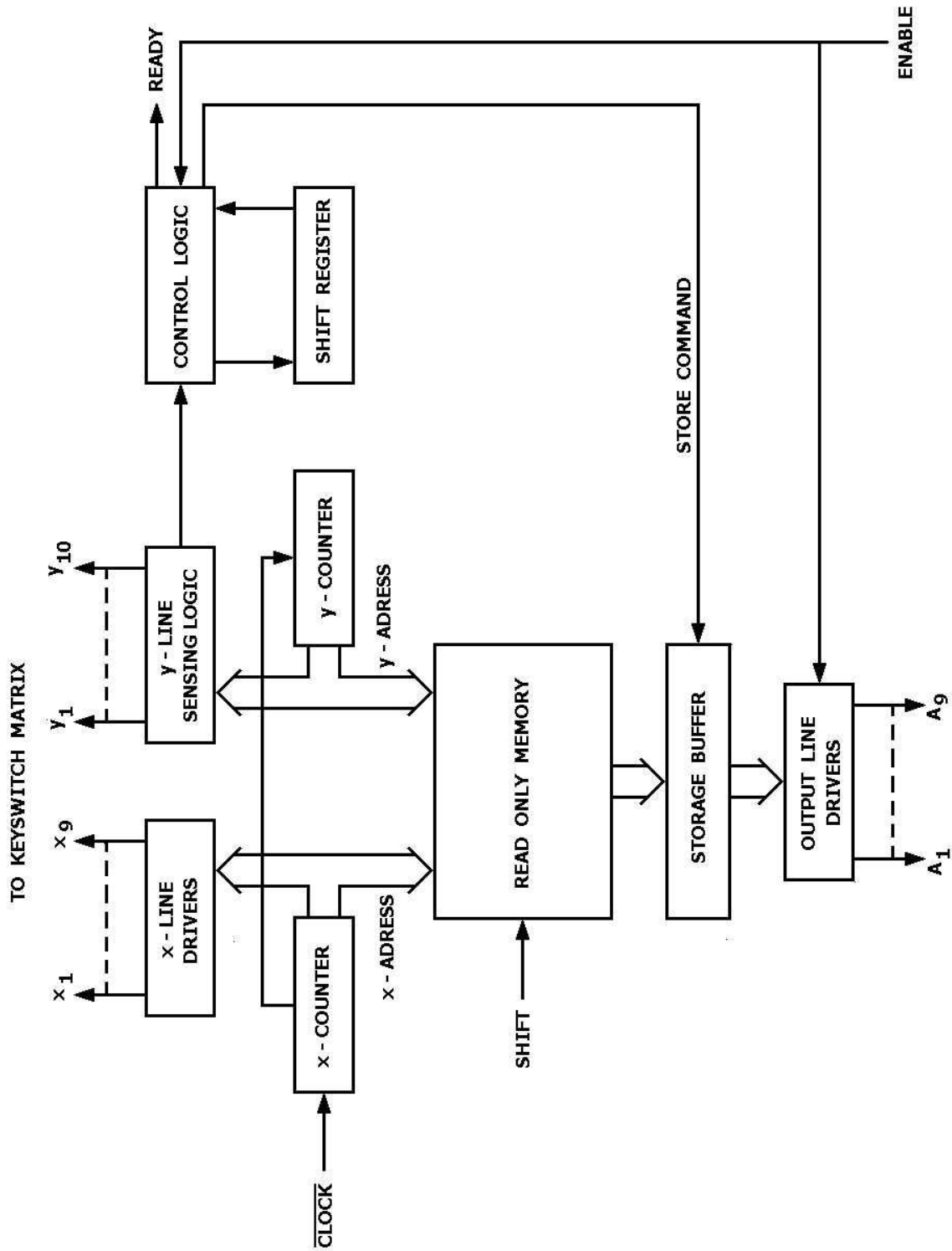

Figure 4.1 MM5740 Keyboard Encoder Integrated Circuit

4.4 Scanning Keyboard Encoder

The transmission of individual characters is initiated by the keyboard encoder section. An integrated circuit keyencoder, in conjunction with a matrix of 46 keyswitches, produces an ASCII code output for each key closure.

The encoder and keyswitch matrix are shown in Figure 8.3. Each keyswitch is represented by a box in the larger rectangle at the left. The rows and columns of the matrix are formed by buses connected to the X and Y terminals of the encoder IC. Any keyswitch, when closed, completes the circuit between one of the X (row) and Y (column) terminals. Thus each keyswitch is assigned a unique pair of x,y coordinates in the matrix.

A block diagram of the encoder IC is shown in Figure 4.1. A dynamic scanning method is used to sense the closure of keyswitches and to produce the required ASCII output code for the corresponding characters. Clock pulses, supplied from the RTTY timing chain (described in Section 4.10), drive the X counter in the IC. As the counter increments, the X (row) lines of the matrix are driven high sequentially.

The Y counter, which increments once for each complete cycle of the X counter, causes the Y (column) sense lines to be monitored in sequence. If a keyswitch is closed, connecting one of the X lines to one of the Y lines, the closure will be detected by the key sense logic circuit when that particular X line is driven high and the Y Line is simultaneously sensed. The state of the counters at the instant the keyclosure is detected then corresponds to the X and Y coordinates of the closed key.

The encoder IC includes a read-only memory (ROM) to convert the coordinates supplied by the counters to the correct ASCII code for the character. Each location in the memory stores the ASCII code for one of the 46 characters³. As the X and Y counters increment, they not only enable the X and Y matrix lines, but also provide an address code to the ROM. Thus the memory locations are addressed in sequence as the key matrix is scanned, and the ASCII codes for each of the keyswitches appear in sequence at the ROM output. As long as the keyswitches remain open, the output of the ROM is ignored. If, however, during the scanning process a closed keyswitch is detected, the key sense logic causes the code appearing at the ROM output at that instant to be transferred to the storage buffer.

The scanning process is dynamic; that is, the counters are cycled repetitively at a fairly high rate, so that key closures are detected almost instantly.

Some of the keys can produce two different characters, a shifted and an unshifted one. The character produced by such a key depends on whether one of the shift keyswitches is closed. If it is, it alters one bit of the address fed to the ROM, thereby accessing a different storage location and producing a different output code.

An important and useful feature of the encoder is the provision for N-key rollover, which is defined as the ability to produce an output code each time a new key is pressed without regard to the condition of the other keyswitches. In practical terms, it means that new key closures will be detected even if the operator has failed to release preceding keys.

During each scan of the key matrix, the output of the sensing circuitry is fed in serial form to a shift register. Once the scan is complete, the register contains a digital "list" of the status of all keyswitches. During the next scan, the register contents are clocked out as the new data are fed in. The register's input and output are compared; if any of the keys have changed state between the scans, the difference will be detected. The control logic then recognizes the new key closure as valid and allows the ROM output code (for the new key only) to enter the storage buffer. Keys which were closed on both scans have no effect on the output, since no change in their state is detected.

When a character has been stored in the buffer and is ready for transfer to the keyboard's code conversion circuit, a data strobe signal (logic high level) appears at pin 13. This strobe drives the keyboard READY bus, signaling the keyboard buffer control circuit that a character is waiting in the encoder's output storage register. This strobe signal also feeds a lamp driver, causing the "memory full" lamp, ID101, to light.

When the keyboard control circuit is ready to accept the waiting character, it returns a signal on the **ENABLE** line, causing the encoder IC's data drivers to transmit the stored character to the keyboard's code

³ The IC's internal memory is actually capable of translating 90 different keys; only 46 are required in the DKB-2010, so the remaining keyswitch positions are left blank.

converter via data lines A₀ through A₆. The data strobe output then goes low, and the memory full lamp is extinguished.

If the operator types slower than the data transmission rate, the **ENABLE** signal is returned to the encoder IC almost instantaneously, so the memory full light is energized only momentarily and therefore does not emit a noticeable flash. On the other hand, if a new character is typed when the storage buffer is full, the lamp will remain lit until the buffer is free, warning the operator that the storage capability of the keyboard will be exceeded by additional keystrokes.

4.5 ROM Code Converter

The seven ASCII code bits from the keyboard encoder are coupled to the input of a 2048-bit read-only memory (ROM), shown with its control logic in Figure 8.4. The ROM is preprogrammed to store both the Baudot and the Morse code equivalents of each ASCII character. An eighth bit, derived from the mode switch via the identifier control circuit, indicates whether the Morse or the Baudot code is to be produced. This bit is supplied to the ROM in parallel with the seven bits from the encoder. Together, these eight bits form the address code fed to the ROM's input.

Each time a character code is fed to the ROM address inputs, a particular eight-bit storage location in the memory is accessed. The data word stored there is either the Baudot or the Morse equivalent of the input (address) word, depending on the state of the eighth bit. The stored bit pattern appears at the ROM outputs in parallel. Thus, the input character is, in effect, converted from ASCII code to the bit pattern required for Baudot or Morse transmission ⁴.

In the RTTY mode, only five of the ROM output bits, D₁ through D₅, are used to represent a particular character. The other three control the RTTY character counter and the automatic case-change circuitry. If the character to be transmitted is in the shifted case (that is, if it requires that the receiving printer be in figures case), the D₀ bit of the ROM output will be high. Fed to the input of the case change flip-flop (Figure 8.5-A6), the bit causes the flip-flop to change states if the preceding character was in letters case. The keyboard then transmits a figures-shift code before producing the current character. Likewise, if the current character is in letters case, but the preceding one was in figures case, the D₀ bit will be low and the letters-shift code will be sent. If two successive characters are in the same case, the D₀ bit does not change, and no case-shift code is transmitted.

The D₆ and D₇ bits control the RTTY character counter (Figure 8.9). This counter keeps track of the number of printing characters transmitted in sequence and lights a warning lamp when the end of the line is approached, signaling the operator to transmit a carriage return and linefeed before proceeding. However, not all characters result in printed output at the receiving end – some, such as the blank, do not print, and thus do not add to the length of the line ⁵. The character counter must therefore be instructed not to count such characters. The D₇ bit of the ROM output is high for each non-printing character, disabling the character counter.

When a carriage return is sent, the character counter must be reset for the start of a new line. The sixth bit, D₆, of the ROM output is low for this character only. The inverted D₆ signal is applied to the character counter flip-flop reset terminals, returning the counter to the zero state when a carriage return is produced.

No case-change code is produced when a non-printing character is sent, as the D₇ line is high and the case change flip-flop is therefore unable to respond to the state of the D₀ bit.

4.6 Storage Buffer

The ROM output character contains the data eventually fed to the shift register, where it is converted from parallel to serial form. Before it reaches the shift register, however, it enters a buffer storage register, shown in Figure 8.4. If the shift register is busy producing a character when the code for the new character appears at the ROM output, the new code will be stored in the buffer until the shift register has completed its cycle and is ready to accept fresh input data.

⁴ Table 4.3 in Section 4.18 lists the ROM output code for each character.

⁵ The non-printing characters are the carriage return, linefeed, blank, letters-shift, figures-shift and bell.

Buffer operation is controlled by the Logic circuit shown at the left in the drawing. When a new character has been produced by the keyboard encoder, the READY line goes high. This signal passes through a NOR gate where it is combined with the ID READY signal. Thus, if a character is ready at either the keyboard or at the identifier, the output of the NOR gate will be low. This terminal is connected to the D input of the first of a string of four flip-flops (IC's 1 and 2). The flip-flop clock terminals are driven by the HØ clock line. On the first positive-going clock transition after the READY signal appears, the first flip-flop changes states, driving pin 5 of circuit 2 low. If the ENABLE KEYBOARD bus is low, the signal passes through two NOR gates and drives the ENABLE terminal of the encoder low, causing the new character to be transferred to the ROM input. The converted character code appears at the output of the ROM, ready for loading into the storage buffer.

Assuming that the buffer is free (that any previous character has been transferred from the buffer to the shift register), the LOAD BUFFER lines, which drive the buffer register clock terminals, will be driven high on the next positive clock transition. The data from the ROM, coupled to the D inputs of the buffer flip-flops, then enters the buffer. On the next clock pulse, the LOAD BUFFER line goes low, preventing further characters from entering until the current character has been transferred to the shift register. One clock pulse later, the ENABLE line goes high, decoupling the keyboard encoder from the ROM input.

When a character is waiting in the buffer register, the last of the four flip-flops is set with its a output high, driving the BUFFER FULL line high. After the contents of the buffer are read into the shift register, the BUFFER READ line is driven low by the shift register control circuitry, resetting the last two flip-flops in the buffer control.

In the case where input data are being supplied to the ROM from the identifier rather than the keyboard, it is necessary to inhibit the identifier sequence when the buffer is full, and to notify the identifier when the buffer is ready to accept a new character. The signal fed to the identifier (and to the other automatic sequencers as well) via the RESUME ID line serves this purpose. When the buffer is full, the line is driven low. As soon as the character in the buffer has been accepted by the shift register, the BUFFER READ Line is driven low, pulling the RESUME ID bus Low also. The identifier then passes a new character to the ROM input, where it is converted and fed to the buffer.

4.7 RTTY Control and Decoding Circuit

When the keyboard is set to the RTTY mode, the transfer of characters from the buffer to the shift register, as well as the subsequent operation of the shift register, is supervised by the RTTY control circuit, shown in Figure 8.5.

The control circuit is composed primarily of the RTTY run flip-flop (IC-15), the case change flip-flop, the case insert flip-flop, and the character timing counter. The latter is a divide-by-16 counter coupled to control gates which reset it to the zero state when a count of fifteen is reached. Its purpose is to control the number of clock pulses reaching the shift register. It passes only enough pulses to clock out the RTTY start pulse, the five character-code bits, and the stop pulse.

The clock input of the counter is driven at twice the baud rate for the RTTY operating speed chosen. The clock pulse source is the 0 output of the RTTY timing chain (Figure 8.8).

Operation of the counter is controlled by the RTTY run flip-flop. Assume for the moment that the shift register is idle, that a character is stored in the buffer, and that the next character typed is in the same case as the one previously transmitted (that is, that no case-change code need be produced). The BUFFER FULL line informs the shift register control circuit that a character is waiting. On the next HØ clock pulse, the character is loaded into the shift register and the RTTY LOAD bus, driven by the shift register control circuit, goes low, as shown by the waveform drawing in Figure 8.5. This transition drives the RTTY run flip-flop to the set state; that is, it sets pin 9 high.

The load command is also fed to the timing chain, where it removes the reset signal from the frequency divider stages and allows timing pulses to flow to the clock input of the character timing counter (pin 14 of IC-27). When the RTTY run flip-flop is set, it drives the RTTY START bus high and opens the NAND gate (part of IC-14) which drives RTTY SHIFT line. The output of the first counter stage is then allowed to pass through the gate. This signal, with a frequency of one-half of the 0 clock rate, is applied to the clock terminals of the shift register, so that the contents of the register are clocked out to the RTTY loop switching circuit.

The output of each stage in the character timing counter is connected to one of the four inputs of a NAND gate (IC-28). When the counter has received fifteen clock pulses, all of the gates inputs are high. The output goes low, resetting the counter before the sixteenth clock pulse arrives. The reset signal is also fed back to pin 11 of IC-14, stopping the flow of clock pulses to the RTTY SHIFT line. Clocking of the shift register consequently stops at the end of the character. The reset signal is also returned to the RTTY run flip-flop, returning it to the clear or "ready" state.

In the event that the new character is in a different case from the preceding one, the sequence of operations is somewhat different. The keyboard must delay transmission of the new character until the letters-case or figures-case code has been sent to change the receiving printer to the correct case. The case code is not produced by the shift register; rather, it is generated by logic gates connected to the character timing counter.

As mentioned in Section 4.5, the D_0 bit from the ROM code converter indicates the case of each character produced. Applied to gates at the input of the case change flip-flop, it is combined with the LOAD RTTY signal and the D_7 bit. When the LOAD RTTY line goes high, indicating that a new character has entered the shift register, and provided that the D_7 bit is high, the D_0 bit passes through the NAND gates to the inputs of the case change flip-flop. If the new character is of a different case than the preceding one, the flip-flop changes states. The flip-flop outputs are dynamically coupled to the preset terminal of the case insert flip-flop, forcing it to the set state. The INSERT CASE CODE Line is driven high, signaling the RTTY encoder to accept an input from the case character generator rather than from the shift register.

An output from the Q or "0" terminal of the case insert flip flop closes the shift register clock gate, preventing clock pulses from flowing to the register. The character stored in the register is therefore held until the case-shift code has been transmitted.

The character timing counter, however, is allowed to run as usual. Its output states are decoded by the case character generator gates (IC-34) to produce the waveforms shown at the bottom of Figure 8.5.

Pin 6 of the gate is low during the "0" and "1" states of the counter, producing the $C = 0v1$ output. Pin 12 is low during the sixth and seventh counts, driving the $C = 6v7$ output low. The $C = 0v1$ output by itself is equivalent to the RTTY letters-shift code. When added to the $C = 6v7$ output, it produces the figures-shift code.

The two signals are fed to the RTTY encoder (Figure 8.7) along with outputs from the case change flip-flop. The latter signals instruct the encoder which of the two case codes is to be generated. The RTTY encoder then uses one or both of these two signals to key the loop and transmit the required case code.

The shift register remains dormant until the case-change character has been completed. At that time, the character timing counter reaches its fifteenth state and the counter reset gate output goes low. This signal resets the counter and the case insert flip-flop. A signal from the flip-flop's Q output, coupled to one input of the NAND gate at the RTTY run flip-flop toggle terminal, prevents the latter flip-flop from being reset. It also opens the shift register clock gate. The character timing counter, which is still receiving clock pulses, restarts at the zero state, but this time clock pulses are allowed to flow to the shift register. As a result, the character stored in the register is clocked out to the RTTY loop keying circuit.

4.8 Shift Register and Control Circuit

Characters arriving from the storage buffer in parallel are converted to serial form by the shift register, shown in Figure 8.6. The register consists of two IC's, each containing five flip-flops. The input code, whether a Morse or RTTY character, is supplied to the register on data Lines D_0 through D_7 . Register operation is controlled by the two flip-flops which comprise IC-7.

In the quiescent state, both the MORSE START and the RTTY START lines are low. These signals are combined in the gates which make up IC-8, driving the output (pin 1) low. Coupled to the reset terminals of the shift register stages, this output clears the register.

As soon as a character has been transferred from the keyboard encoder to the storage buffer, the BUFFER FULL line goes high. On the next positive-going transition of the HØ clock, the first of the shift register control flip-flops toggles, and its Q output drives the BUFFER READ line low. The same signal passes

through an inverter to drive the gates at the inputs of the shift register stages high, allowing data from the storage buffer to enter.

If the keyboard is in the RTTY mode, the M/R line is high, and the Q or "1" output of the first control flip-flop (pin 9 of IC-7) passes through a NAND gate (part of IC-16) to drive the RTTY LOAD line low. This signal is returned to the RTTY control circuit (Figure 8.5), where it sets the RTTY run flip-flop. The RTTY START line, driven high by the RTTY run flip-flop output, is combined with the M/R bus in a NOR gate (IC-8), with the result that the shift register reset bus is driven high, allowing the flip-flops to assume the states of the incoming data lines.

Similarly, if the keyboard is in the Morse mode, the MORSE START signal, supplied from the Morse character generator (Figure 8.10), goes high when the character generator is ready to accept data for a new character, releasing the shift register reset terminals.

Once the character has been loaded into the register, it is ready to be clocked out to the RTTY loop keying circuit or the Morse character generator, depending on the mode selected. Clock pulses are supplied to the clock terminals of the register stages from either the RTTY control circuitry via the RTTY SHIFT line or from the Morse character generator on the MORSE SHIFT line. In Morse mode, the RTTY LOAD line is inhibited by the low input on the M/R bus connected to pin 2 of IC-16; hence, the RTTY run flip-flop is not set at the beginning of a character, and the RTTY control circuit does not produce clock pulses. Conversely, the Morse clock oscillator is inhibited during RTTY operation, so that the only clock pulses reaching the shift register are those from the RTTY control circuit.

Each time a positive-going clock transition occurs, the contents of the register shift one stage of the right. Consequently, the input data, which arrive at the register in parallel form, appear at the register output bus (labeled SHIFT REGISTER) serially. From there the character code passes to the Morse character generator and the RTTY encoder and loop interface. One or the other of these circuits is activated, depending on the setting of the mode switch, and the desired Morse or RTTY output is produced.

The pattern of bits loaded into the shift register depends on the keyboard mode. Let us consider the RTTY mode first. Each RTTY character code consists of seven pulses: a start pulse (always a space), five select pulses which define the character, and a stop pulse (always a mark) which is about 50 per cent longer than the other pulses.

The character code from the ROM code converter passes through the storage buffer and appears on data lines D₀ through D₇. Lines D₁ through D₅ define the character. As mentioned in Section 4.5, bit D₀ is used in the RTTY mode to signal the case code circuit when a case change occurs. Hence, it is not loaded into the shift register. Although it appears at one input of a NAND gate (pin 13 of IC-18) connected to the data input of the first register stage, it is prevented from passing to the stage by the low level on the M/R bus, which is tied to the other gate input. Consequently, the gate output remains high, and the first stage is set unconditionally to the "1" state to produce the start pulse (a space).

Bits D₁ through D₅ are loaded into the second through sixth stages of the shift register when the BUFFER READ line is low and the RTTY START bus goes high.

Bits D₆ and D₇, like the D₀ bit, are used in the RTTY mode for control functions rather than as part of the character code. They are also blocked from the shift register inputs by gates (part of IC-11). The high level on the M/R bus holds the gate outputs low regardless of the levels on the D₆ and D₇ lines. As a result, stages 7, 8 and 9 remain in the "0" state. The tenth stage is also left in the "0" state, since its data input is grounded.

Once the input data have been loaded into the register flip-flops, the character timing counter becomes active and clock pulses flow to the shift register. The frequency of the 0 clock signal supplied to the counter is divided by two in the first counter flip-flop, so that the shift register is clocked at the proper baud rate for the RTTY speed chosen.

Figure 4.2 illustrates the timing and register states for transmission of the character "F" (space-mark-space-mark-mark-space-mark). Note that the stop pulse is the required 50 per cent longer than the other select pulses.

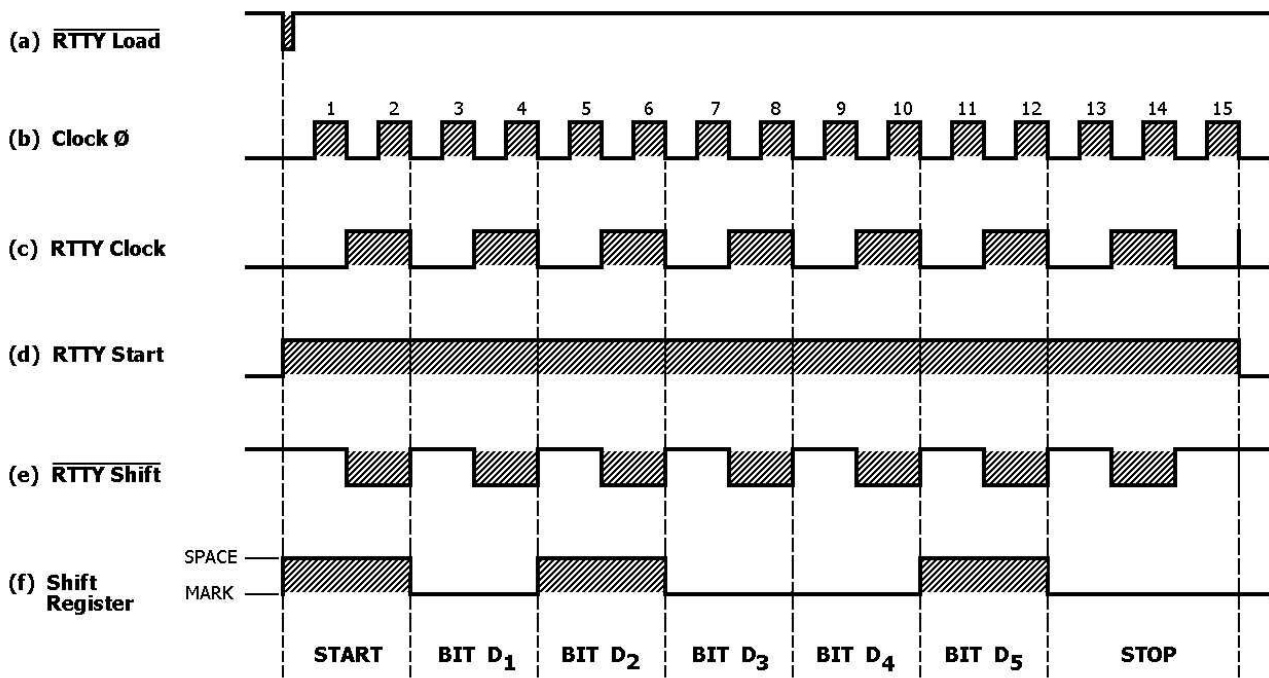

Figure 4.2 Shift Register Waveform for Transmission of the Letter "F"

In the Morse mode, all eight data lines from the storage buffer are available to carry the character code. The M/R and M/R lines are switched to the high and low states, respectively, opening the gates at the inputs of the first, seventh and eighth register stages. Of course, the ROM code converter is instructed to produce the Morse rather than the RTTY character code, as described in Section 4.5.

As soon as a new character is stored in the buffer register, the BUFFER FULL line goes high. When the Morse character generator has completed transmission of the preceding character, the MORSE START line goes low, pulling the reset terminal of the second shift register control flip-flop low. Consequently, the flip-flop's Q output goes high. This output, coupled to the clear terminal of the first control flip-flop, allows the latter flip-flop to toggle on the next positive-going HØ clock pulse, as shown in Figure 4.3. The BUFFER READ line is driven low by the flip-flop's Q output and the code bits on lines D₀ through D₇ enter the shift register.

The bit pattern loaded into the register determines the sequence of dots and dashes produced by the Morse character generator. A register stage set to the "0" state produces a dash; set to the "1" state it produces a dot.

Since Morse characters are not all of equal length (that is, they do not have the same number of dots and dashes), not all of the eight incoming data lines are needed to produce many of the characters. The ROM code converter is programmed to follow the required bits for each character with an "end" bit set to the "1" state, with all remaining bits set low. For example, the code supplied for the letter "C" (dash-dot-dash-dot) is 00011010. Reading from right to left, the first (right-most) register stage is set to the "0" state to produce the first dash. The next stage is set to the "1" state to produce a dot, and so on through the first four stages. The fifth bit from the right is set to the "1" state to indicate the end of the character. All remaining stages are set to "0".

A signal must be provided to the Morse character generator to indicate when the last of the character bits has been clocked out. For this purpose, the inputs of a six-input NOR gate, composed of a hex inverter with its open-collector outputs wired in parallel (IC-17), are connected to the second through seventh stages of the shift register. If any of these stages is set to the "1" state, the MORSE END line is held low. Since the last character bit is always followed by a "1" bit, the gate output will go low initially regardless of the length or bit pattern of the character code loaded into the shift register.

As the character bits shift to the right, they are fed to the Morse character generator. At the same time, the register stages are progressively loaded with "0"s, since the data input of the last register stage is grounded. When the "end" bit reaches the first stage, all remaining stages are set to "0" and all six inputs of the NOR gate are low. The MORSE END line consequently goes high, signaling the end of the character. The

"end" bit is used by the Morse character generator to produce a space between characters, as explained in Section 4.12.

In the RTTY mode, data bits are clocked out of the shift register at a constant rate, as all select pulses are of the same duration. In Morse operation, however, the dashes are three times as long as the dots. The register clock rate therefore depends on the code pattern. The clock pulse is supplied by the Morse character generator rather than a fixed clock oscillator. The output of the character generator is inverted and fed to the shift register clock bus via the MORSE SHIFT line. A shift occurs at the end of each dot or dash, shifting the data bit for the next code pulse to the register output, from which it passes to the character generator.

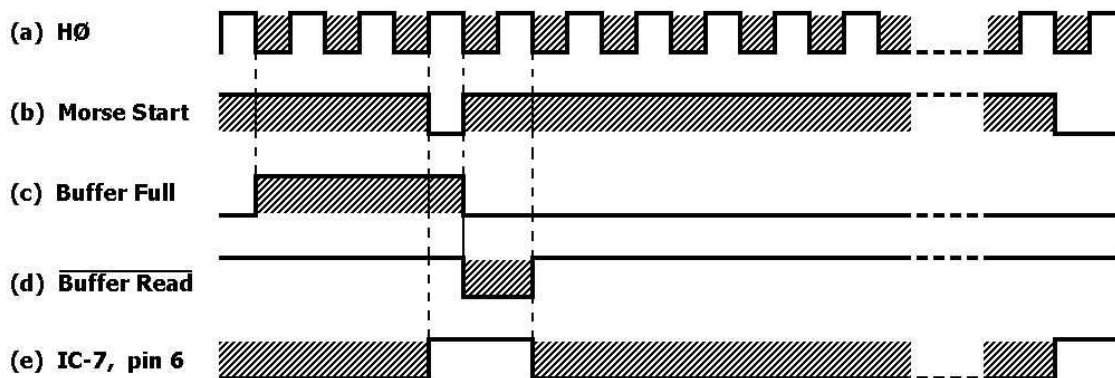

Figure 4.3 Shift Register Control Signals for Morse Operation

4.9 RTTY Encoder and Loop Interface

The serial output data bits from the shift register are coupled to both the RTTY encoder (Figure 8.7) and the Morse character generator. With the keyboard in the RTTY mode, the Morse circuit is disabled and the output bits activate only the RTTY loop keying circuitry.

The RTTY encoder accepts data inputs from three sources: the shift register output, the case character generator, and the BREAK key circuit. Control inputs are received from the case change flip-flop, the case insert flip-flop, and the M/R bus.

The Loop circuit is keyed by an NPN transistor, Q2, which is isolated from ground and the power supply bus by a transformer in its base circuit. During mark pulses, the VH0 clock signal passes through a NAND gate (IC-34) and an inverter (IC-24) to drive the emitter of a current source, transistor Q1. The pulses are coupled through transformer T1 to a half-wave rectifier circuit, the output of which drives the keying transistor into conduction. During space pulses, the VH0 clock signal is prevented from reaching the keying circuit by a low level at pin 9 or 11 of IC-34.

During normal operation when a case change is not required, the gate is controlled by the output of the shift register, which is applied to one input of a NAND gate (pin 9 of IC-33). With the case change circuitry inactive, pin 11 of the gate is held high. The M/R bus is also high, holding pin 10 high. The shift register signal therefore appears inverted at the gate output. When the register output is high the gate output is low. This signal, fed to pin 11 of IC-34, cuts off the flow of VH0 clock pulses to the keying circuit and loop current is prevented from flowing. Conversely, when the register output is low, the gate output is high and, assuming that the BREAK line is low (BREAK key released), clock pulses flow and the keying transistor conducts.

The BREAK key is provided to manually interrupt the loop circuit. When the keyswitch is closed, the BREAK line is high. Fed to the input of a NAND gate (part of IC-55), it is combined with a signal from the M/R bus, which is high when the keyboard is in the RTTY mode. With the BREAK line high, the gate output is forced low, preventing clock pulses from reaching the keying circuit. The loop current is therefore interrupted until the key is released.

As described in Section 4.7, the RTTY control circuit detects when a change of case is necessary. In this instance, the shift register is disabled until after the case code has been transmitted. The register output remains high during this period. Clock pulses are controlled by the logic circuit shown at the left in Figure 8.7.

The case-code character to be transmitted is selected by the NAND gates at the far left (parts of IC's 28 and 33). At the beginning of the character the INSERT CASE CODE line, coupled to one input of each gate, goes high. If the letter-shift character is to be sent, the LTRS CASE bus goes high, enabling the lower gate. The FIGS CASE line remains low, disabling the upper gate, so its output remains high. The $C = 0v1$ signal then appears, inverted, at the gate output, as shown in Figure 4.4.

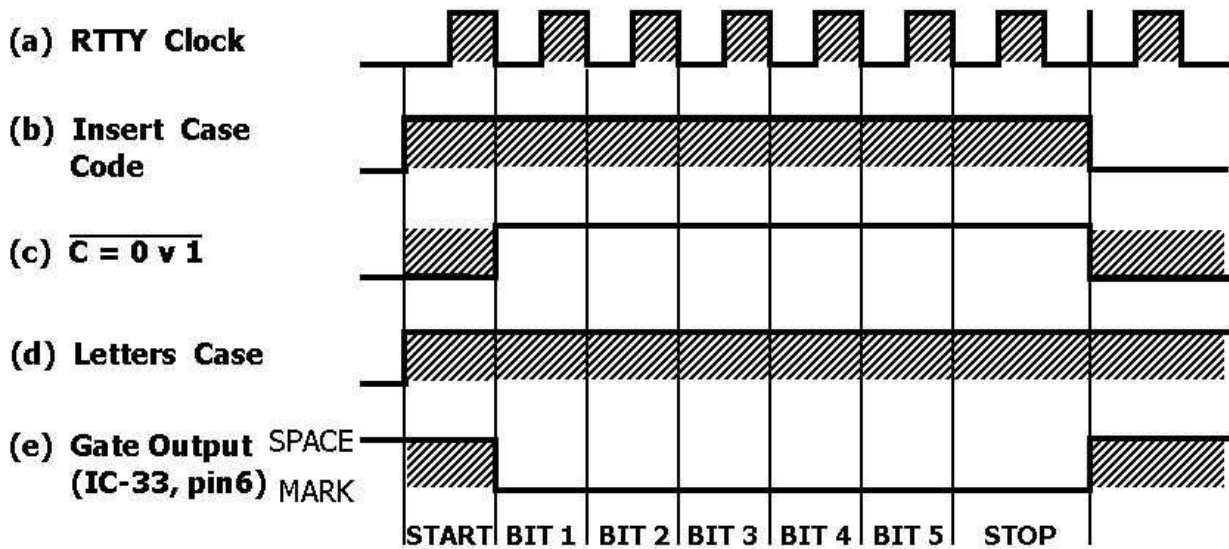

Figure 4.4 Generation of the Letters - Shift Code

If, on the other hand, the figures-shift code is required, the FIGS CASE line is high, enabling the upper gate. The LTRS CASE line is low, so that the lower gate is closed and its output remains high. Both the $c = 0v1$ and the $C = 6v7$ signals are coupled to inputs of the upper gate with the result that these signals are logically added to produce the figures-shift character, as shown in Figure 4.5.

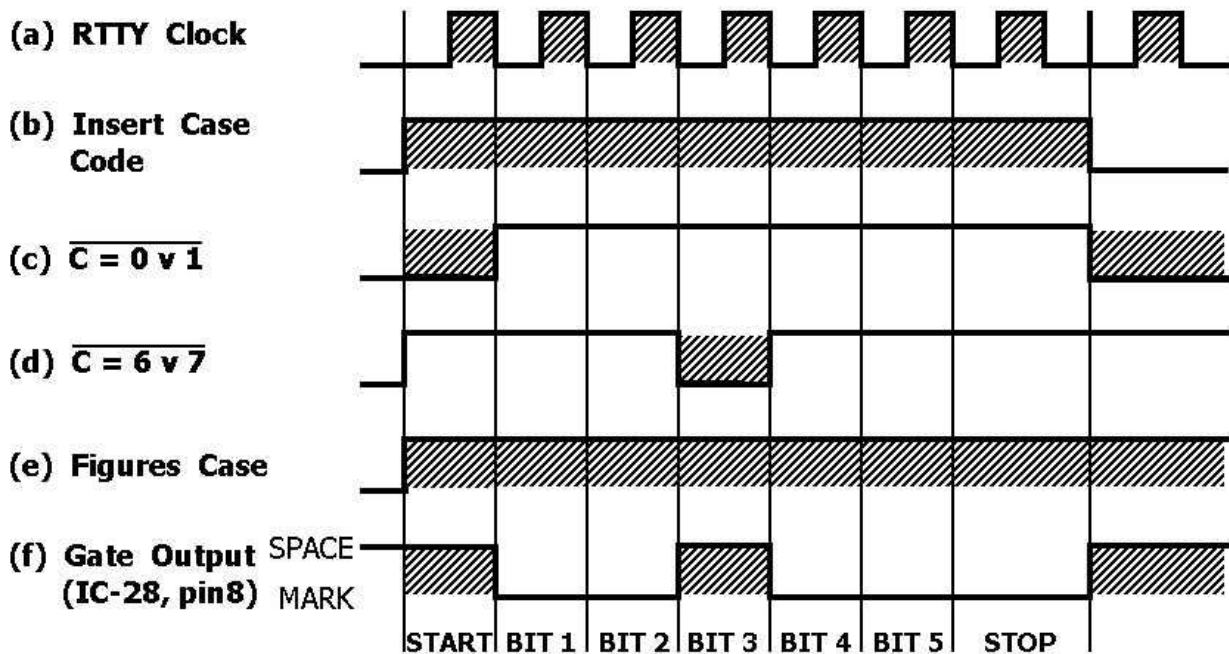

Figure 4.5 Generation of the Figures - Shift Code

The case-change code is coupled through a NAND gate (part of IC-25) and an inverter to IC-33, where it is used in place of the shift register output to control the keying circuit.

When the keyboard is switched to the Morse mode, the M/R bus goes low. Since this signal is coupled to pin 10 of IC-33 and Pin 10 of IC-55, the outputs of both these gates remain high. Clock pulses are thus allowed to flow to the keying circuit, and the RTTY loop is held in the mark state. One section of the mode switch, S301B, also shorts across the loop keying contacts in the Morse mode as a means of completing the loop circuit when the keyboard power is switched off.

4.10 RTTY Timing Chain

Accurate timing pulses for RTTY operation are derived from four crystal-controlled oscillators, one for each RTTY speed, as shown in Figure 8.8. The outputs of the oscillators are fed to four separate NAND gates. Only one of the gates is enabled at any time, as determined by the setting of the mode switch, S301A.

The gate outputs are coupled through a NOR gate, composed of four open collector inverters (part of IC-30), to the input of a sixteen-bit binary counter. Consequently, the clock signal appropriate to the RTTY operating speed chosen is supplied to the counter.

The first four stages of the counter, which divide the input frequency by a factor of sixteen, drive the VHØ clock line. This signal, in the range from about 375 to 610 kHz (depending on the operating speed), is used in the RTTY loop interface (Figure 8.7) to drive the isolation circuit during mark pulses. It is also supplied to the quick brown fox generator to clear the circuit rapidly in the Morse mode.

In the next four counter stages, the frequency is again divided by sixteen to obtain the HØ clock signal, which toggles at 512 times the baud rate. The HØ clock line synchronizes operation of the keyboard encoder (Figure 8.3) with the buffer control and the shift register control circuits (Figures 8.4 and 8.6, respectively).

The HØ clock signal is again divided by the remaining eight counter stages to produce the Ø clock signal at twice the baud rate. The reset terminals of the last four stages are controlled by the RTTY START line, which clears the flip-flops between characters and allows clock pulses to flow only after a character has been transferred from the storage buffer to the shift register. The reset feature also ensures that the first shift of the register will occur exactly one select-pulse duration after the beginning of the start pulse.

Table 4.1 lists the frequencies of the four oscillators, as well as the corresponding VHØ, HØ and Ø clock frequencies for each RTTY speed.

Also shown in Figure 8.8 is the circuit which drives the M/R and the M/R lines. In the RTTY mode, the input to an inverter (pin 9 of IC-30) is pulled high by resistor R21, which is connected to the +5 Volt supply bus. The M/R line is therefore high and the M/R bus is driven low. Conversely, when the switch is moved to the Morse position, the inverter input is grounded, pulling the M/R bus low and allowing the M/R line to go high.

Table 4.1: RTTY Timing Chain Output Frequencies

RTTY Operating Speed (WpM)	Oscillator Frequency (kHz)	VHØ Clock Rate (kHz)	HØ Clock Rate (kHz)	Ø Clock Rate (kHz)
100	9730.660	608.166	38.010	148.478
75	7459.988	466.249	29.141	113.830
66	6553.600	409.600	25.600	100.000
60	5957.818	372.364	23.273	90.909

Supplied to other portions of the keyboard circuitry, these signals activate the RTTY control and encoder circuits in the RTTY mode, and the Morse character generator and output control circuits in the Morse mode. They also control the input to the shift register, determine the character code produced in the ROM code converter, and inhibit the operation of the quick brown fox generator in the Morse mode.

Although the output of the RTTY timing chain is not used to clock the shift register in the Morse mode, $VH\emptyset$ and $H\emptyset$ clock pulses are still needed in the keyencoder, buffer control, and RTTY loop interface circuits. The M/R bus is therefore connected through diode D8 to pin 8 of IC-35. With the mode switch set to the Morse position, the gate input is pulled low, allowing the 60 WpM oscillator to drive the timing chain. As a result, the required clock signals are produced.

Another inverter, part of IC-30, is used to invert the BREAK signal from the BREAK keyswitch. The output is used in the RTTY encoder to interrupt the loop current and in the stage when the BREAK key is pressed.

4.11 RTTY Character Counter

When the keyboard is in the RTTY mode, a character counter keeps track of the number of characters transmitted and warns the operator when the end of a line is approached. The counter is reset each time a carriage return is transmitted, and is instructed not to count non-printing characters. When 64 printing characters have been produced since the most recent carriage return, the counter output lights an indicator lamp and triggers the sidetone oscillator to produce an audible warning.

The counter, shown in Figure 8.9, consists of six flip-flops arranged as an ordinary binary counter, and a control circuit. The clock signal is supplied from the RTTY control and decoding circuit (Figure 8.5) via the RTTY LOAD line. Each time a character is loaded into the shift register, the counter increments, provided that the D_7 data line from the ROM code converter is low. As discussed in Section 4.5, the D_7 line is low for all printing characters, but is high for non-printing ones. The D_7 signal is applied to the J and K inputs of the flip-flop, which toggles only when both input terminals are high.

The D_6 line is high only for the carriage return character. When this character is loaded into the register, both the D_6 line and the RTTY LOAD bus are high. These signals, applied to the inputs of a NAND gate (part of IC-25), drive the gate output low, resetting all stages of the counter.

After 32 input pulses, the counter output goes high; after the 64th pulse it goes low again. The counter output is fed to the clock input of another flip-flop (part of IC-23). When the counter completes its cycle, the flip-flop toggles, driving the base of a PNP transistor, Q3, low. Since the emitter of the transistor is biased to +5 Volt, the transistor conducts and the end-of-line warning lamp lights. The flip-flop's reset terminal is connected to the output of the gate which drives the counter reset bus, so that the warning lamp is extinguished when a carriage return is transmitted. The flip-flop's Q output is also coupled to the trigger terminal of a monostable multivibrator (IC-13). The negative-going transition at the end of the 64th count causes the monostable to toggle to the set state for a short period. The RTTY TONE line is driven low, activating the sidetone oscillator (Figure 8.11) during the monostable period.

4.12 Morse Character Generator

The function of the Morse character generator, shown in Figure 8.10, is to convert the sequential output bits from the shift register to a series of short and long pulses corresponding to the dots and dashes of Morse code.

The cycle of operation is initiated when a character is transferred to the shift register from the storage buffer. The MORSE END line, driven through an inverter from the shift register end-of-character sensing circuit, goes high, setting the oscillator control flip-flop. The Q output of the flip-flop (pin 5 of IC-15) goes high, driving the MORSE START line high and enabling a NAND gate which controls the Morse oscillator.

The oscillator, consisting of the NAND gate (part of IC-14) and two inverters, determines the Morse transmission rate. The oscillator frequency is controlled by the front-panel Morse speed control, P301. The oscillator output is coupled to the input of a three-bit counter (IC-26); its inverted output is fed to the input of the dot flip-flop (pin 5 of IC-23). The counter states are decoded by a 4-line-to-10-line decoder (IC-31) to produce sequential pulses on its output lines, as shown in Figure 4.6 (for clarity, only the first four output lines are shown).

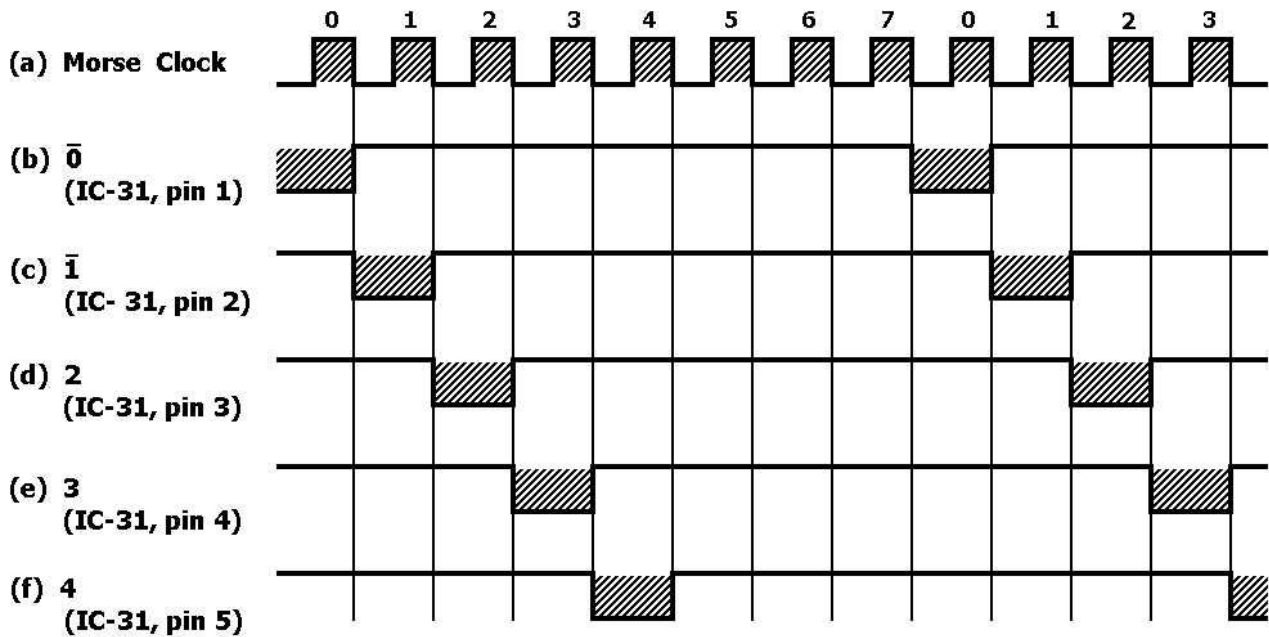

Figure 4.6 Morse Clock and Decoder Waveform

The 0 output of IC-31 is connected through an inverter to the J input of the dot flip-flop. The output from one of the remaining lines is selected by the weight control (S302), inverted, and fed to the K input. When the counter is in the "0" state, the dot flip-flop's J input is therefore high and its K input is low.

On the first negative-going clock transition, the dot flip-flop assumes the state of its J and K inputs; that is, it toggles to the "1" state, as shown in Figure 4.7. The DOT line, connected to the toggle input of the dash flip-flop (pin 11 of IC-22) goes high.

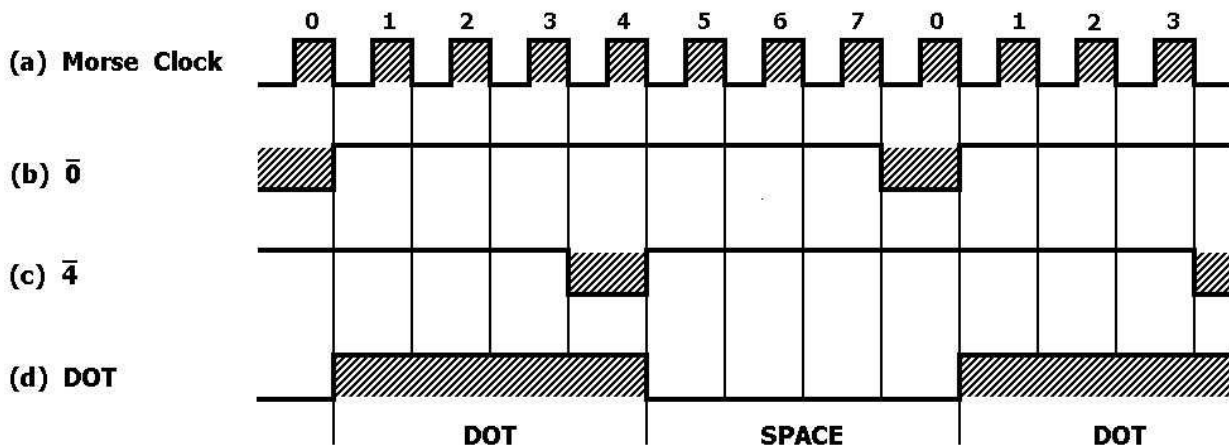

Figure 4.7 Production of Dots by the Morse Character Generator

Assuming for the moment that S302 is set for normal weight, the K input of the flip-flop is driven by decoder output 4 (pin 5). During the next three clock pulses, the flip-flop does not change states because its J and K inputs are held low. After clock pulse 3, however, the decoder 4 output goes low, driving the flip-flop's K input high. On the next negative-going clock transition, the flip-flop changes back to its original state, pulling the DOT line low. The flip-flop does not revert to the set condition until the counter has completed its cycle and a new bit has been supplied by the shift register. The dot pulse is therefore followed by a space.

Because it is possible to select which decoder input is used to reset the dot flip-flop, the duty cycle of the output may be varied. The duration of the dot as compared to that of the following space may be set for any ratio from 1:7 to 3:1. Four of the six possible weight ratios are selectable by the weight switch, as determined by the position of the jumpers on the circuit board.

The 7 output of the decoder is fed back to the clock input of the oscillator control flip-flop. When the counter has received seven clock pulses, the 7 line goes low. On the eighth clock pulse, it returns to the high state. This positive transition will cause the oscillator control flip-flop to reset if the end of the character has been reached, stopping the oscillator. If not, the low level on the MORSE END line holds the flip-flop's preset terminal low, the flip-flop remains set, and the oscillator continues to run to produce the next dot or dash. The "0" output of the dot flip-flop is coupled through a NAND gate to the MORSE CHARACTER line, which carries the signal to the Morse output control circuit. It is ultimately used to activate the transmitter keying transistor.

If the shift register output is high during the operation just described, the clear input to the dash flip-flop (pin 13 of IC-22) is held low, preventing any change of state. If, on the other hand, the character to be produced is a dash, the shift register output is low, and the dash flip-flop is free to toggle when the DOT line goes high, as shown in Figure 4.8. The dash flip-flop then divides the dot line frequency by two. The DASH line and the DOT line are supplied to two inputs of a NAND gate (pins 4 and 5 of IC-18). During the production of dots, the DASH line is held high, and the output of the dot flip-flop is coupled through the gate to the Morse character bus. For dashes, both flip-flops are active, and the two output lines are logically added in the gate, as shown in trace g of Figure 4.8.

At the end of each complete Morse character, it is necessary to include a space equal in length to three dots. After all character bits have been clocked from the shift register to the Morse generator, the MORSE END line goes high and thus can no longer hold the oscillator control flip-flop in the set state. However, recall that an extra "1" bit (the end bit) is loaded into the shift register in the position immediately following the last character bit. The SHIFT REGISTER bus is fed to one input of the NOR gate which drives the control flip-flop preset terminal. The clock therefore continues to run for eight additional oscillator pulses, as shown in Figure 4.9 , producing an extra dot. This dot is passed to a NAND gate in the Morse output control circuit, where it is combined with the MORSE END signal. Since the latter line goes low at the end of the character bits the extra dot does not pass to the gate output and is not transmitted.

The MORSE CHARACTER output is inverted in a NOR gate (part of IC-8) to produce the MORSE SHIFT signal. Fed back to the shift register, it causes the register to shift at the end of each dot or dash, providing the bit for the next Morse pulse to the input of the character generator. The waveform drawing included in Figure 8.10 shows the key signals for generation of the Letter K (dash-dot-dash).

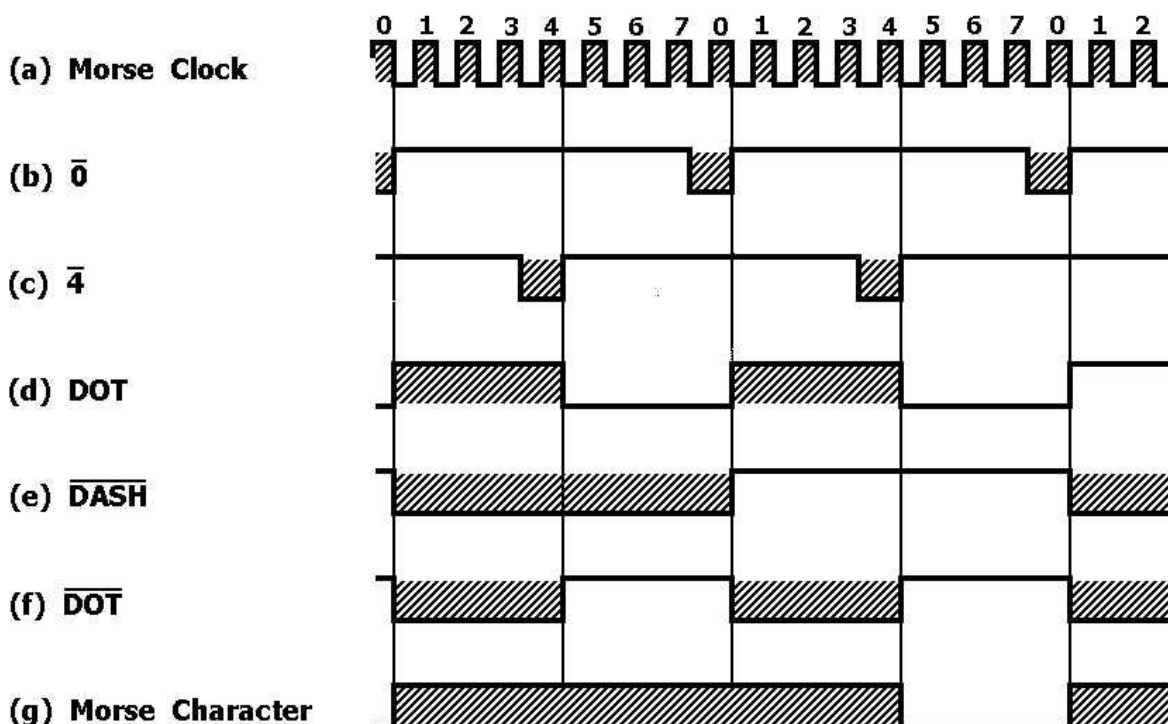

Figure 4.8 Production of Dashes by the Morse Character Generator

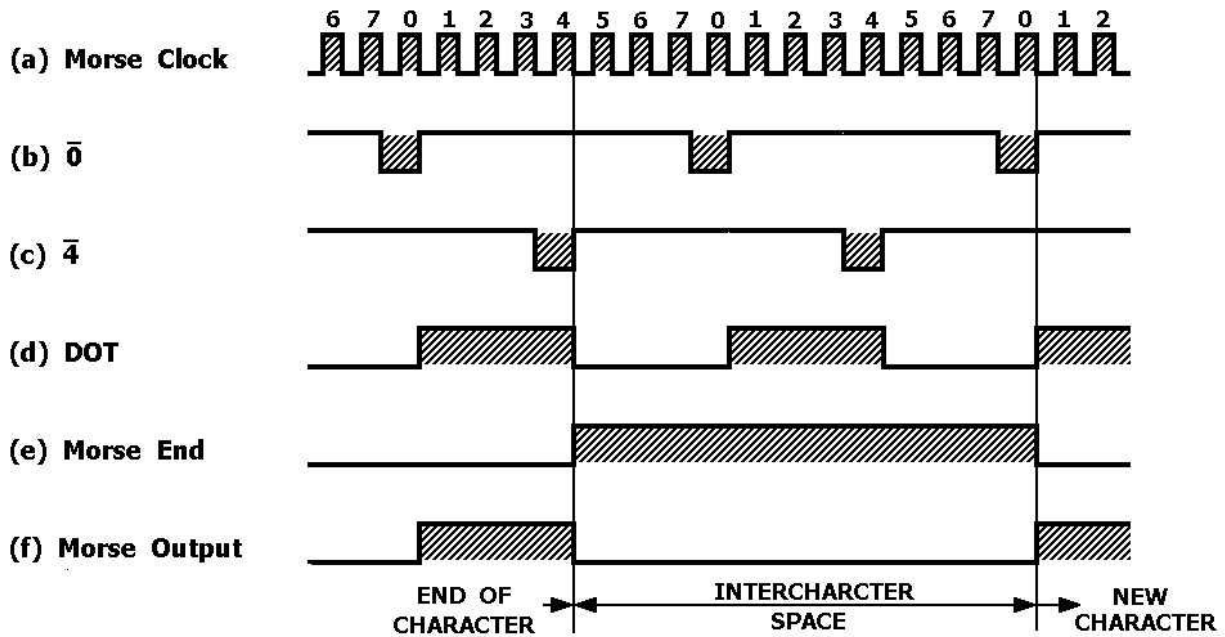

Figure 4.9 Suppression of Extra Dot to Produce Intercharacter Space

4.13 Morse Output Control

The Morse output control, shown in Figure 8.11, accepts inputs from the Morse character generator, the BREAK key, and the RTTY character counter. It controls both the transmitter keying transistor and the sidetone oscillator.

The MORSE CHARACTER line and the MORSE END line are applied to the inputs of a NAND gate (pins 9 and 10 of IC-18). During the production of character pulses, the MORSE END line remains high and the pulses from the MORSE CHARACTER line appear inverted at the gate output. As explained in Section 4.12, the MORSE END line goes low during the production of the dot which follows each character, resulting in an intercharacter space.

The M/R bus and the BREAK line are applied to the two inputs of another NAND gate (pins 12 and 13 of IC-55). Since the M/R bus is always high in the Morse mode, the output of the gate is low whenever the BREAK key is pressed.

The outputs of the two gates are applied to the inputs of a third NAND gate (pins 1 and 2 of IC-18). If either of the inputs is low, the output goes high. With the BREAK line low, the Morse character pulses appear at the gate output. When the BREAK key is pressed, the gate output remains high regardless of the incoming character pulses.

The output of the third gate drives the emitter of Q6, a constant current source, which in turn drives the transmitter keying transistor, Q5. When the gate output is high, the keying transistor conducts. The transistor output may be connected for either cathode or grid-block keying, depending on which of the two output jacks is used. For cathode keying, the cathode lead from the transmitter is connected to the collector of Q5. The emitter is grounded through the grid-block jack. When the transistor is driven into conduction, cathode current flows.

If the grid-block keying method is used, the transmitter's grid biasing circuit is connected to the emitter keying transistor. The collector is grounded through the cathode jack. When the transistor conducts, it shorts the bias source to ground.

A diode and capacitor are connected across the keying transistor to protect it from surges and the application of reverse voltages.

The input signals also drive the sidetone oscillator through an inverter (part of IC-24) and a NAND gate (pins 1-3 of IC-55). The RTTY TONE bus, which originates in the RTTY character counter circuit (figure 8.9), is also applied to the gate input. If either the MORSE CHARACTER or BREAK line is high, or if the RTTY TONE line is low, the gate output goes high. This signal is coupled to the input of another NAND gate (pin 4 of IC-55) which forms part of the sidetone oscillator. When the gate input is high, the oscillator is enabled.

The oscillator consists of the control gate, two inverters and an RC network which determines the operating frequency. Variable resistor P1 permits adjustment of the frequency. The output of the oscillator (pin 10 of IC-24) drives the base of a current amplifier transistor, Q4. The output signal is developed across the collector load resistor, P302, which controls the level fed to the speaker and, through an isolating capacitor, to the audio output jack.

4.14 Quick Brown Fox Generator and ID Control

The purpose of the quick brown fox (QBF) generator is to produce the standard RTTY test message (The quick brown fox jumps over the Lazy dog's back 0123456789) with a single keystroke. The circuit, shown in Figure 8.12, also includes logic to control the operation of the identifier and the three-character sequencers, to be described in later sections.

The QBF test message characters are stored in two sections of the ROM code converter, each containing 32 addresses. The remaining six sections of the ROM store the RTTY and Morse codes for each ASCII character supplied by the keyboard encoder. When the QBF generator is active, the keyboard is disabled and the address input of the ROM (data lines A₀ through A₇) is driven by the QBF generator instead.

The generator's character sequence is controlled by a six-bit counter. The output of the five least significant stages are coupled through diodes to data lines A₀ through A₄. Lines A₅ and A₆, used in normal RTTY operation to signal control functions, are driven low for the entire time the generator is active. The A₇ line, which normally selects the Morse or the RTTY portion of the ROM, is connected to the most significant counter stage. When the generator has been activated, the counter increments through its 64 states. During the first 32 states, the storage locations in the first of the two ROM QBF sections are addressed sequentially by the counter output, producing the first half of the test message. On the 32nd input pulse, the A₇ line changes state and selects the second of the two QBF sections. The next 32 characters then appear at the ROM output as the counter increments.

The generator cycle is initiated when the QBF key is pressed, pulling the **QUICK BROWN FOX START** line low. If the mode switch is set for RTTY operation, the M/R line is low also. Both signals are coupled to the input of a NOR gate (pins 2 and 3 of IC-54). With the key pressed, both inputs are low and the output, coupled to a gate at the clear terminals of the first four counter stages, goes high. The other gate input is connected to the **ID ACTIVE** line. If either the identifier or one of the three-character sequencers is active, the line is low, preventing the QBF counters from resetting. If, on the other hand, the **ID ACTIVE** line is high, the QBF counter reset terminals are allowed to go high and the counter is reset. Note that the clear terminals of the two most significant stages are driven by a separate NAND gate (pins 3, 4, and 5 of IC-52). These stages reset when their clear terminals are driven Low.

The Q output of each counter stage is coupled to an input of a NAND gate (IC-51). When the counter has cycled through all of its 64 states, all inputs to the gate are high and its output is low. The circuit remains in this state until the next time the test sequence is initiated. As soon as the QBF key closes, the counter resets, and the output of IC-51 goes high. This signal is coupled through another NAND gate whose output (pin 8 of IC-52) is combined with the **HERE IS ACTIVE** line and the inverted **THREE LETTER GROUP ACTIVE** line in a four-input NAND gate.

The output of the latter gate (pin 6 of IC-44) drives the **ENABLE KEYBOARD** line. If any of the automatic character string generators is active, the **ENABLE KEYBOARD** line goes high. Fed back to the buffer control circuit, this signal prevents the keyboard encoder from producing character codes until the character string has been completed.

When the counters have been reset by closure of the QBF key and the **ENABLE KEYBOARD** line has gone high, the **ID ACTIVE** line is driven low. Since the latter signal is coupled to the NAND gate at the counter clear terminals, its transition removes the clear command produced by the QBF key closure and the counter is free to toggle as pulses reach its input stage.

Clock pulses are supplied to the counter from the buffer control circuit via the **RESUME ID** line, which drives the **READY ID** line through a NAND gate. The gate is inhibited during normal keyboard operation, since the **ENABLE KEYBOARD** line stays low, When any of the automatic sequencers is active, however, the gate opens and pulses are allowed to flow to the counter.

The input pulses are derived from the buffer control circuit because the identifier must be instructed to produce each successive output code only when the buffer is ready to receive it. Characters are loaded from the ROM code converter into the buffer when the LOAD BUFFER line goes high momentarily. As shown in Figure 4.10, the RESUME ID line goes low for two H \emptyset clock pulses shortly after the character has been loaded. This signal is inverted to produce the READY ID signal, which clocks the QBF counter. The counter increments, providing a new character at the storage buffer input. After the preceding character has been transmitted, the LOAD BUFFER line goes high again, and the new character enters the buffer. The process continues until the test message is completed.

When the counter has received 63 such pulses, all counter Q outputs are high. The output of gate IC-51 goes low, driving the ENABLE KEYBOARD line high and preventing further clock pulses from reaching the counter. The cycle of operation is then complete, and, unless the QBF key is held down, the keyboard is restored to normal operation.

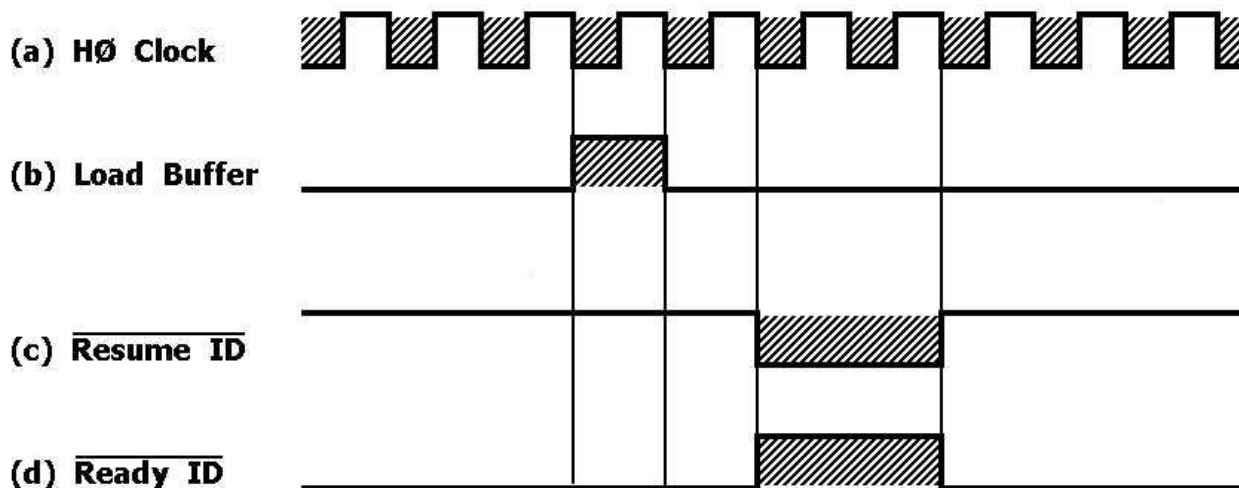

Figure 4.10 Development of Clock Pulses for Automatic Character Sequencers

Since the ROM is coded to produce only RTTY codes for the QBF message, the output is incomprehensible when the keyboard is in the Morse code. The input from the QUICK BROWN FOX START line is disabled in that case by a high level on the M/R line applied to pin 3 of IC-54. The counters cannot be reset and the circuit remains inactive.

It is not possible, however, to predict the states the counter stages will assume when the power is first switched on; the circuit may start in the active state. To clear the counter quickly in the Morse mode, the VH \emptyset clock signal is supplied to a NAND gate (pin 1 of IC-52), If the QBF circuit is active, indicated by a high level on pin 13 of the gate, and if the keyboard is in the Morse mode, indicated by a high level on the M/R line pin 2, the VH \emptyset clock signal is applied to the counter input, so that the counter very rapidly increments until it reaches its 64th state. It then becomes inactive and normal Morse operation can begin.

4.15 Identifier

The circuit which automatically transmits the station identification message operates on a principle quite similar to that of the QBF generator. The character codes, however, are not stored in the ROM code converter, instead, a diode matrix read-only memory is used so that the message may be altered if desired by simply repositioning the diodes in the memory matrix. The matrix output produces the ASCII code for the message characters. These codes are supplied to the ROM code converter on data lines A₀ through A₆ in place of those normally produced by the keyboard encoder. The circuit is shown in Figure 8.13.

The identification sequencer uses a four-bit counter, the output states of which are decoded by IC's 40 and 42. As the counter increments, the decoder output lines go low in sequence. Each line represents one character in the stored message.

Diodes are connected from each line to the A₀ through A₆ data lines in those positions required to produce the ASCII code for the character. When the decoder line goes low, those A lines to which diodes are connected go low also. When the converted character code has entered the storage buffer, the counter

increments, the next decoder line goes low, and the code for the next message character appears on the data lines ready to be loaded into the buffer. For reference, a complete listing of the ASCII codes used is given in Table 4.2 in Section 4.18.

To initiate the identification cycle, the HERE IS keyswitch is closed, pulling the **HERE IS START** line low. The signal is inverted and fed to a gate at the counter reset input. The other input to the gate is driven by the **ID ACTIVE** line. If the QBF generator or either of the three-character sequencers is active, the line is low and the identifier counters cannot be reset. If not, the counter resets as soon as the key is pressed and the **HERE IS ACTIVE** line goes low. As a result, the ID ACTIVE signal, fed back from the ID control circuitry, also goes low, removing the reset signal from the counter, so that it may begin its count sequence. Clock pulses are supplied to the counter from the **READY ID** line, which goes high for two H \emptyset clock pulses whenever the storage buffer is ready to accept a new character, just as in the QBF generator.

To indicate the end of the message, a jumper is connected from the decoder output which follows the last line used for the message codes (the 3 output of IC-40 in the example shown in Figure 8.13). When all characters in the message have been produced, this last line goes low, driving the **HERE IS ACTIVE** line high and closing the NOR gate at the counter input. The flow of clock pulses then stops. The counter remains inactive until the HERE IS key is pressed again. If the key is held down, the message repeats immediately.

4.16 Three-Character Sequencers

Two three-character sequencer circuits are provided, each of which can automatically produce a string of three characters at a single keyswitch closure. One, activated by the CQ key, is coded to produce the letters CQ followed by a space. The other is programmed at the user's option for any desired message.

The circuit, shown in Figure 8.14, is essentially a simpler version of the identifier. Each sequencer contains a two-bit counter wired to stop counting after the third input pulse. The counter outputs are decoded by NAND gates to drive the X lines of a diode matrix. Diodes are positioned between the decoder output lines and the ASCII data lines to produce the required character codes.

The operating cycle for the CQ generator is initiated by closure of the CQ keyswitch. The AUX key controls the other sequencer. When either counter has been reset, the THREE LETTER GROUP ACTIVE line, driven from the counter outputs, goes high. Fed to the ID control circuit, this signal prevents the other automatic character sequencers from being activated, and allows clock pulses to appear on the **READY ID** line. When the active counter reaches its fourth state, the THREE LETTER GROUP ACTIVE line goes low, and the flow of clock pulses ceases. If the keyswitch is held closed, the counter resets again and the cycle repeats. If not, the sequencer becomes inactive.

4.17 Power Supply

DC power for the keyboard is provided by two regulated supplies, shown in Figure 8.15. The majority of the logic circuits operate from the +5 Volt supply. The output of a full-wave rectifier is regulated by a pair of transistors, Q201 and Q202, connected in series with the load. The output voltage is controlled by an active feedback circuit composed of transistors Q203 and Q204. The output voltage is adjusted by means of potentiometer P201.

The ROM code converter and keyboard encoder IC's require a source of -12 Volts DC. This voltage is supplied by a separate transformer and a voltage-doubling rectifier circuit. It is regulated by a series-pass transistor, Q205, which drives its base bias from a zener diode, D203. The output voltage is therefore not adjustable.

The transformer primaries may be wired for either nominal 115 or 230 Volt AC inputs. Both power supplies are protected by a fuse, F301, in the primary circuit.

4.18 Character Codes

The tables on the following pages list the various character codes used in the DKB-2010 keyboard.

Table 4.2 tabulates that portion of the ASCII character set produced by the keyencoder circuit. Only those ASCII characters which correspond to Military Standard Baudot characters are used. The codes, which appear at the keyencoder output on data lines A₀ through A₆, are listed in the table opposite the characters they represent. The A₆ bit is listed first, followed by the other bits in descending order, with the bit for line A₀ at the right. Note that the keyencoder output logic is negative true; that is, a "1" represents a low level (less than 0.8 Volt), and a "0" represents a high level (from 2.4 to 5.0 Volt).

As discussed in Section 4.5, the ASCII code is converted by a ROM to a different bit pattern before being loaded into the shift register. The ROM output, which appears on lines D₀ through D₇, is listed in Table 4.3 along with the character each code represents and with the corresponding ASCII input code. The ROM produces different outputs for Morse and RTTY modes, depending on the state of the A₇ input bit. Both output codes are listed for each character. Since some of the characters are not available in the Morse mode, the output bits for such characters consist entirely of "0's". The bits are listed in descending order, with the D₇ bit at the left. As in the ASCII code listing, the logic is negative true.

Table 4.4 lists the Military Standard Baudot code produced by the keyboard in the RTTY mode. The code for each RTTY character is made up of seven bits – a start pulse, five character-defining select pulses and a stop pulse. Since the start bit is always a space and the stop bit is always a mark, they are not shown in the table, only the five select pulses are listed. Note that the same code may be used to produce two different characters, depending on the case to which the receiving teleprinter is set – letters or figures.

In Table 4.5 the keyboard output codes for each of the Morse characters is listed. In comparing these codes to the ROM code converter output bits, recall that the ROM is programmed to include an extra dot bit at the end of each character for generation of the intercharacter space.

Table 4.2: ASCII Character Codes Used in the DKB-2010

KEY	Unshifted A ₆ → A ₀	Shifted A ₆ → A ₀
A	100 0001	100 0001
B	100 0010	100 0010
C	100 0011	100 0011
D	100 0100	100 0100
E	100 0101	100 0101
F	100 0110	100 0110
G	100 0111	100 0111
H	100 1000	100 1000
I	100 1001	100 1001
J	100 1010	100 1010
K	100 1011	100 1011
L	100 1100	100 1100
M	100 1101	100 1101
N	100 1110	100 1110
O	100 1111	100 1111
P	101 0000	101 0000
Q	101 0001	101 0001
R	101 0010	101 0010
S	101 0011	101 0011
T	101 0100	101 0100
U	101 0101	101 0101
V	101 0110	101 0110
W	101 0111	101 0111
X	101 1000	101 1000
Y	101 1001	101 1001
Z	101 1010	101 1010
∅	011 0000	011 0000
!	011 0001	010 0001
"	011 0010	010 0010
#	011 0011	010 0011
\$	011 0100	010 0100
5	011 0101	010 0101
&	011 0110	010 0110

KEY	Unshifted A ₆ → A ₀	Shifted A ₆ → A ₀
'	011 0111	010 0111
7	011 0111	010 0111
(011 1000	010 1000
8	011 1000	010 1000
)	011 1001	010 1001
9	011 1001	010 1001
SK	011 1010	010 1010
:	011 1010	010 1010
AS	010 1101	011 1101
-	010 1101	011 1101
KN RETURN	000 1101	000 1101
AR LF	000 1010	000 1010
BT	011 1011	010 1011
;	011 1011	010 1011
BLANK	000 1011	000 1011
?	010 1111	011 1111
/	010 1111	011 1111
SPACE	010 0000	010 0000
FIGS	010 1110	011 1110
.	010 1110	011 1110
LTRS	010 1100	011 1100
,	010 1100	011 1100
QBF	Control function*	
HERE IS	Control function*	
BRK	Control function*	
CQ	Control function*	
AUX	Control function*	

* These keys do not directly produce ASCII code

All logic states shown are negative true;
 "0" = +2.4 to 5.0 Volt; "1" = 0.0 to +0.8 Volt

Table 4.3: ROM Converter Input and Output Codes

RTTY			RTTY			Morse		
A ₆ → A ₀	D ₇ → D ₀	CHAR	A ₇ → A ₀	D ₇ → D ₀	CHAR	A ₇ → A ₀	D ₇ → D ₀	CHAR
000 0000	0000 0001	b	010 0010	1010 0110	2	1101 1100	1101 1100	2
000 0001	0000 0001	b	010 0011	1000 0010	3	1101 1000	1000 0010	3
000 0010	0000 0001	b	010 0100	1001 0100	4	1101 0000	1001 0100	4
000 0011	0000 0001	b	010 0101	1010 0000	5	1100 0000	1010 0000	5
000 0100	0000 0001	b	010 0110	1010 1010	6	1100 0001	1010 1010	6
000 0101	0000 0001	b	011 0111	1000 1110	7	1100 0111	1000 1110	7
000 0110	0000 0001	b	011 1000	1000 1100	8	1100 0111	1000 1100	8
000 0111	0000 0001	b	011 1001	1011 0000	9	1100 1111	1011 0000	9
000 1000	0000 0001	b	011 1010	1011 0001	SK	1010 1000	1011 0001	SK
000 1001	0000 0001	b	011 1011	1011 1100	BT	1010 0001	1011 1100	BT
000 1010	0000 0101	LF	011 1100	0011 1110	LTRS	0000 0000	0000 0000	ERR
000 1011	0000 0001	b	011 1101	0000 0001	b	1010 0001	1010 0001	ERR
000 1100	0000 0001	b	011 1110	0011 0111	FIGS	0000 0000	0000 0000	ERR
000 1101	0101 0001	CR	011 1111	1011 0110	?	1000 1100	1000 1100	?
000 1110	0000 0001	b	100 0000	0000 0001	b	0000 0000	0000 0000	ERR
000 1111	0000 0001	b	100 0001	1000 0111	A	1111 1010	1111 1010	A
001 0000	0000 0001	b	100 0010	1011 0011	B	1110 0001	1110 0001	B
001 0001	0000 0001	b	100 0011	1001 1101	C	1110 0101	1110 0101	C
001 0010	0000 0001	b	100 0100	1001 0011	D	1111 0001	1111 0001	D
001 0011	0000 0001	b	100 0101	1000 0011	E	1111 1100	1111 1100	E
001 0100	0000 0001	b	100 0110	1001 1011	F	1110 0100	1110 0100	F
001 0101	0000 0001	b	100 0111	1011 0101	G	1111 0011	1111 0011	G
001 0110	0000 0001	b	100 1000	1010 1001	H	1110 0000	1110 0000	H
001 0111	0000 0001	b	100 1001	1000 1101	I	1111 1000	1111 1000	I
001 1000	0000 0001	b	100 1010	1001 0111	J	1110 1110	1110 1110	J
001 1001	0000 0001	b	100 1011	1001 1111	K	1111 0101	1111 0101	K
001 1010	0000 0001	b	100 1100	1010 0101	L	1110 0010	1110 0010	L
001 1011	0000 0001	b	100 1101	1011 0001	M	1111 1011	1111 1011	M
001 1100	0000 0001	b	100 1110	1001 1001	N	1111 0001	1111 0001	N
001 1101	0000 0001	b	100 1111	1001 1101	O	1111 0001	1111 0001	O
001 1110	0000 0001	b	101 0000	1010 1101	P	1110 0110	1110 0110	P
001 1111	0000 0001	b	101 0001	1010 1111	Q	1110 1011	1110 1011	Q
010 0000	1000 1001	SPC	101 0010	1001 0101	R	1111 0010	1111 0010	R
010 0001	1001 1010	"	101 0011	1000 1011	S	1111 0000	1111 0000	S
010 0010	1010 0010	"	101 0100	1010 0001	T	1111 1101	1111 1101	T
010 0011	1010 1000	#	101 0101	1000 1111	U	1111 0100	1111 0100	U
010 0100	1001 0010	\$	101 0110	1011 1101	V	1110 1000	1110 1000	V
010 0101	0000 0001	b	101 0111	1010 0111	W	1111 0110	1111 0110	W
010 0110	1011 0100	+	101 1000	1011 1011	X	1110 1001	1110 1001	X
010 0111	1001 0110	"	101 1001	1010 1011	Y	1110 1101	1110 1101	Y
010 1000	1001 1110	(101 1010	1010 0011	Z	1110 0011	1110 0011	Z
010 1001	1010 0100)	101 1011	0000 0001	b	0000 0000	0000 0000	ERR
010 1010	1000 1010	BELL	101 1100	0000 0001	b	0000 0000	0000 0000	ERR
010 1011	1000 0001	b	101 1101	0000 0001	b	0000 0000	0000 0000	ERR
010 1100	1001 1000	"	101 1110	0000 0001	b	0000 0000	0000 0000	ERR
010 1101	1000 0110	-	1100 0010	0000 0001	b	0000 0000	0000 0000	ERR
010 1110	1011 1000	/	1010 1010	0000 0001	b	0000 0000	0000 0000	ERR
010 1111	1011 1010	/	1100 1001	0000 0001	b	0000 0000	0000 0000	ERR
011 0000	1010 1100	1	1101 1111	0000 0001	b	0000 0000	0000 0000	ERR
011 0001	1010 1110	1	1101 1110	0000 0001	b	0000 0000	0000 0000	ERR

Notes:

- b denotes blank
 - LF denotes line feed
 - CR denotes carriage return
 - SPC denotes space
 - ERR denotes Morse error (8 dots)
- All ROM input and output logic states are negative true.
 "0" = +2.4 to +5.0 volts
 "1" = 0.0 to +0.8 volts
- RTTY Mode: "0" = space; "1" = mark
 Morse Mode: "0" = dot; "1" = dash

Table 4.4: RTTY Baudot Code (Military Standard)

Bit Number 5 4 3 2 1	Case	
	Letters	Figures
0 0 0 0 0	BLANK	BLANK
0 0 0 0 1	E	3
0 0 0 1 0	LF	LF
0 0 0 1 1	A	-
0 0 1 0 0	SPACE	SPACE
0 0 1 0 1	S	BELL
0 0 1 1 0	I	8
0 0 1 1 1	U	7
0 1 0 0 0	CR	CR
0 1 0 0 1	D	\$
0 1 0 1 0	R	4
0 1 0 1 1	J	'
0 1 1 0 0	N	,
0 1 1 0 1	F	!
0 1 1 1 0	C	:
0 1 1 1 1	K	(
1 0 0 0 0	T	5
1 0 0 0 1	Z	"
1 0 0 1 0	L)
1 0 0 1 1	W	2
1 0 1 0 0	H	#
1 0 1 0 1	Y	6
1 0 1 1 0	P	Ø
1 0 1 1 1	Q	1
1 1 0 0 0	O	9
1 1 0 0 1	B	?
1 1 0 1 0	G	&
1 1 0 1 1	FIGS	FIGS
1 1 1 0 0	M	.
1 1 1 0 1	X	/
1 1 1 1 0	V	;
1 1 1 1 1	LTRS	LTRS

Notes:

1 = mark
0 = space

LF denotes line feed
CR denotes carriage return

The order of transmission is bit 1 to bit 5. A start bit (logical "0") precedes bit 1 and 1 to 2 stop bits (logical "1") follow bit 5.

Figures case H is the STOP character in Military Standard Baudot Code. The # character is used by the HAL Visual Display System to indicate the STOP code.

Table 4.5: Morse Codes

<u>Character</u>	<u>Code</u>	<u>Character</u>	<u>Code</u>
A	· -	∅	- - - - -
B	- · · ·	1	· - - - -
C	- · - ·	2	· · - - -
D	- · ·	3	· · · - -
E	·	4	· · · · -
F	· · - ·	5	· · · · ·
G	- - - ·	6	- · · · ·
H	· · · ·	7	- - - · ·
I	· ·	8	- - - · ·
J	· - - - -	9	- - - - ·
K	- · -	"	· - · · ·
L	· - · ·	.	· - - - - ·
M	- -	(- · - - · -
N	- ·)	- · - - · -
O	- - -	:	- - - · · ·
P	· - - ·	;	- · · - · ·
Q	- - - · -	,	- - - · - - -
R	· - ·	/	- · · - ·
S	· · ·	-	- · · · · -
T	-	?	· · - - · ·
U	· · -	AS	· - · · ·
V	· · · -	SK	· · · - - -
W	· - -	BT	- · · · -
X	- · · -	AR	· - · - ·
Y	- · - -	KN	- · - - ·
Z	- - - ·	ERROR	· · · · · ·

V. ASSEMBLY INSTRUCTIONS

The DKB-2010 is no longer available in kit form. Chapter V has been deleted from this manual with the exception of Section 5.13 which covers coding of the identifier.

5.13 Coding the Identifier

In addition to the regular letter and number keys, the keyboard provides three automatic sequence keys. Each of these keys can be precoded with a series of characters which are automatically transmitted when the key is depressed. Two of the keys, the CQ and AUX keys, can each store a three-character sequence. In most applications, the CQ key is coded to transmit the letters C and Q plus a space. The AUX key is often coded to transmit the letters D and X followed by a space. Note that coding a space character after the two letters ensures that proper spacing is preserved then the sequence is transmitted repeatedly by holding the key down. Of course, either of these keys can be programmed for any other sequence of up to three characters. A popular use of the AUX key for RTTY operation is to generate the sequence "Carriage Return (CR) - Line Feed (LF) - Letters". However, the AUX key is then not useful in Morse mode since the Morse sequence would be "KN - AR - error (8 dots)". Factory wired DKB keyboards are coded for "D - X - space" unless otherwise specified.

The third automatic key, designated HERE IS, can automatically produce a sequence of up to 15 characters. Most users prefer to precode it with a station identification message: the letters D and E, followed by a space and the station call letters.

The automatic sequence keys are precoded by inserting diodes at the proper location in the diode matrix on the logic circuit board. The diodes are positioned to represent the ASCII code for each character in the sequence.

An enlarged view of the matrix is shown in Figure 5.13. Each horizontal path represents one character in the precoded sequence. The first three lines are used for the three characters produced by the CQ key; the next three are for the AUX key. The remaining 15 are for the characters of the HERE IS key sequence.

To determine the positions at which diodes should be installed it is necessary to refer to the ASCII code chart (Table 4.2) at the end of Section 4 of this manual. The ASCII code for each character is represented there by a series of ones and zeros.

Before starting to code the matrix, write down on a piece of scratch paper the exact message you would like to store for each of the three keys. Be sure to include a mark to indicate where you wish spaces to occur.

Next, enter your message in the left column of the following chart, under the heading "Character," starting at the top. Note that the first three spaces are for the CQ key, the next three are for the AUX key, and the remaining spaces are for the HERE IS key.

Once you have listed the characters, refer to Table 4.2 to obtain the ASCII code for each character. Note that in the table the code is given for bits A₆ through A₀ from left to right. In the identifier coding chart, however, the bits are listed in the reverse order, A₀ through A₆. When you have obtained the ASCII code pattern (the sequence of ones and zeros) for a given character from Table 4.2, reverse the order and record them opposite that character in the coding chart.

Table 5.1 Coding Chart for Identifier

Character		A ₀	A ₁	A ₂	A ₃	A ₄	A ₅	A ₆
CQ key								
AUX key								
HERE IS key								

Table 5.1 Coding Chart for Identifier

Character		A ₀	A ₁	A ₂	A ₃	A ₄	A ₅	A ₆
CQ key								
AUX key								
HERE IS key								

As an example, let us assume that the CQ key is to be coded with the three characters C, Q and a space. Here is how we would fill in the chart:

Character		A ₀	A ₁	A ₂	A ₃	A ₄	A ₅	A ₆
CQ key	C	1	0	0	1	0	0	1
	Q	1	0	0	0	1	0	1
	SPACE	0	0	0	0	0	1	0

From Table 4.2, we see that the code for the first character, C, is 100 0011. Reversing the order, we have 1100 001, which we enter in the first line of the coding chart. The code for Q is 101 0001. Reversing the order, we have 1000 101, which we enter opposite the a in the chart. The space code is 010 0000, which we reverse and enter opposite the "SPACE" row in the chart.

Note that in Table 4.2, there are two code columns for each character – a shifted and an unshifted one. For the letter keys, these two codes are the same. For some keys, however, the shifted code is different, and it produces a different character from the unshifted one. For example, the "1" key produces an exclamation point if it is struck when one of the shift keys is held down. Similarly, the "2" key produces quotation marks if the shift key is used.

Therefore, it is important to select the code from the correct column. If you want the identifier to produce the character which appears on the lower half of the keytop, use the code from the "unshifted" column. If you want the character appearing on the top half of the keytop, use the code from the "shifted" column.

Now go through the table and place a large X in each square which contains a one, as shown in the sample chart. These X's will correspond to the position of the diodes in the matrix on the logic board. Two copies of Table 5.1 are included so that a different coding can be set up in the future.

177. Check to make sure that the AC power cord has been disconnected from the outlet. Then remove the logic circuit board from the bottom cover and position it on your work surface with the component side up and the connector strip nearest you. The diode matrix will now be at the left edge of the board and will be positioned as indicated by Figure 5.14.
178. The figure shows how the diodes should be positioned for the CQ key. Note that the diodes are inserted into the board from the component side. Referring to the table you have prepared, install diodes in the matrix at the appropriate positions. The diodes should be stood on end, with the cathode end (the end to which the colored bands are closest) furthest from the surface of the board. Be sure that the diode body is over the row of holes **not** connected by a conductor strip, as shown in Figure 5.14. Solder the diode leads on the reverse side of the board and cut off excess leads.
179. Locate the jumper wire which was installed during initial assembly from a hole at the right edge of IC-40 to one of the rows in the diode matrix. Disconnect the matrix end of the wire from the circuit board. Note that a row of holes is provided along the right edge of the matrix, labeled with numbers 1 through 16 in Figure 5.14. Count the number of rows you have used for the HERE IS (identifier) message, including any blanks or spaces. Add one to that number to obtain the number of the hole to which the jumper should be connected. Then insert the free end of the jumper wire in the hole and solder. As a double check, the jumper should be attached to a hole which is connected by a printed conductor to the row of diode holes immediately following the last row of diodes you inserted in the identifier portion of the matrix.
180. Reinstall the logic board on the bottom cover panel and secure it in place with four 6-32 keep nuts. Be sure to put nylon washers on the screws at holes A and C as described in step 171. Reconnect the AC power cord and switch the keyboard on, being careful not to touch exposed wiring. Wait a minute for the sequencers to clear themselves. Check that the keyboard is still set to the Morse mode. Then press the CQ key and check that the proper character sequence is transmitted. Do the same for the AUX and HERE IS keys. If the message sequence is executed correctly, disconnect the AC cord. If not, recheck the position and installation of all diodes. If correct, refer to the troubleshooting section of this manual.

181. Install the bottom cover to the keyboard cabinet, being careful to tuck in the wiring harness so that it is not pinched. Note that the front edge of the cover fits inside the lip of the cabinet. The rear lip of the cover should be on the outside of the rear panel. Check again that the wiring harness is not pinched between the cover and the cabinet; then fasten the cover in place with four 6-32 x 5/6" screws, one at the front lip and three at the rear.

Assembly of the keyboard is now complete. To prevent possible damage to the keyboard circuitry, be sure to read the installation instructions in Section 2 of this manual before attempting to hook up and use your keyboard.

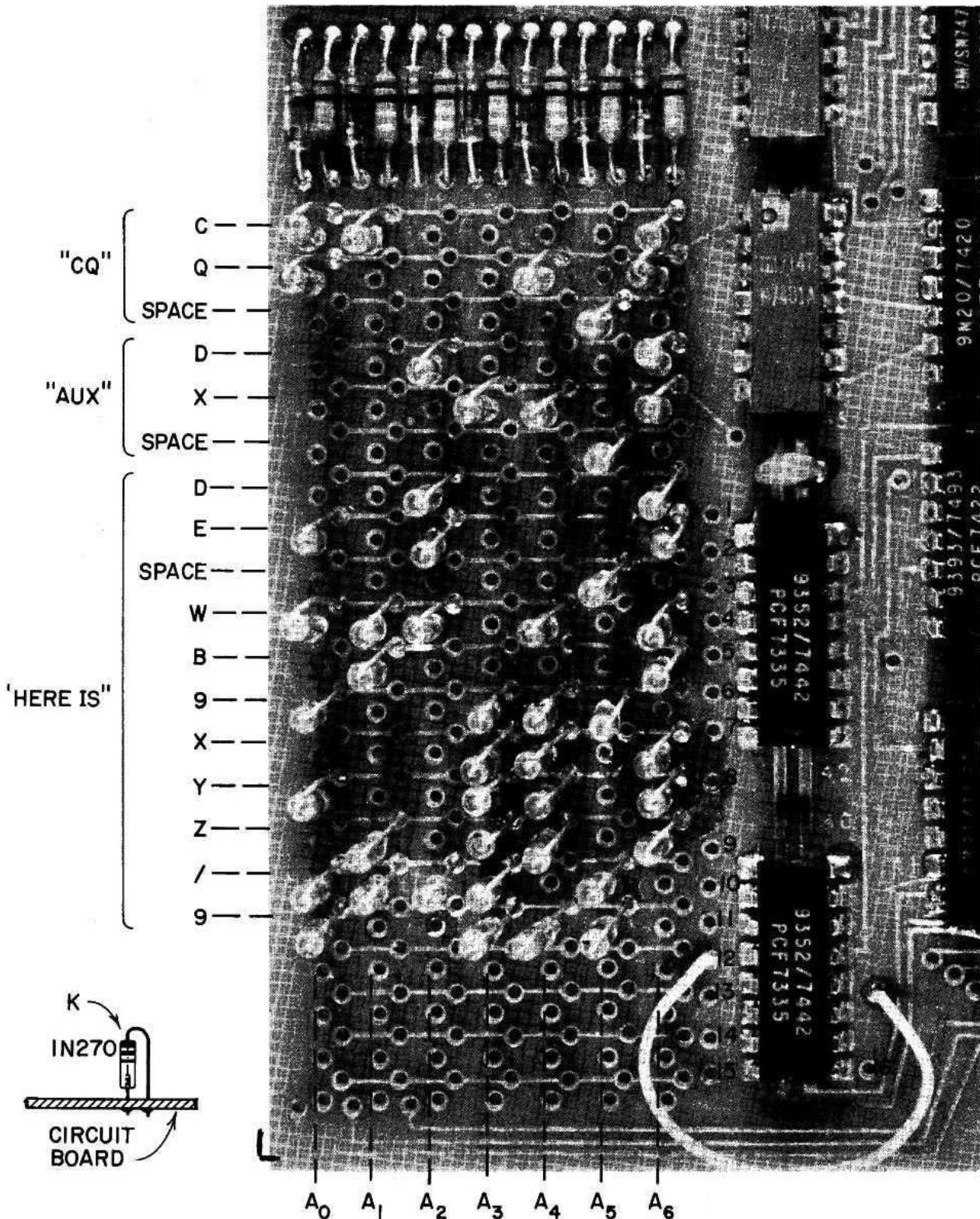

Figure 5.14 Diode placement in Identifier Matrix

VI. MAINTENANCE

When properly assembled and installed, your DKB-2010 keyboard should provide years of trouble-free service. No routine maintenance or adjustment is required. As with any electronic device, individual components may fail as a result of aging. The tips presented in this section will help isolate the source of such difficulties should they occur.

The logic circuitry used in the keyboard is comparatively complex. The servicing suggestions presented here, however, are limited to basic checks that can be made with fairly commonplace test instruments. Unless the reader is familiar with integrated digital logic circuits and systems, it is recommended that the more complicated service problems be referred to the factory.

Service Procedures

The DKB-2010 is constructed with high quality materials throughout. The G-10 epoxy-glass circuit boards are used in preference to less costly materials because of their durability. Nonetheless, a reasonable amount of care should be exercised when removing and installing components. It is particularly important that the connections not be overheated with the soldering iron, as excessive heat may cause the printed conductors to separate from the epoxyglass substrate. Refer to Section 5.3 for more detailed soldering instructions.

Component removal requires particular care, as it is often necessary to heat more than one pin at a time to unsolder the component. In some cases, it may be safer to break the component and remove the pins from the board one at a time. If this method is not practical, as in the case when the component is expensive or a replacement is not readily available, several other techniques may be used. Specially shaped soldering iron tips are available which allow heating all pins of a component, such as a 14-pin DIP integrated circuit, simultaneously.

Solder wicking – essentially very fine copper braid – can be used to absorb solder from the pins once the solder has been melted with a small iron. Touch the end of the wicking to the pin; it will draw up the excess solder by capillary action, leaving the pin free.

The solder may also be removed by any of a variety of suction devices marketed for that purpose. All are equipped with a rubber bulb and a tube with a solder- and heat-resistant tip. The connection is first heated with a soldering iron. The air is expelled from the suction device by squeezing the bulb. The tip is then placed on the connection and the bulb is released. The molten solder is carried up into the tube with the inrush of air.

Troubleshooting

Two of the most common problems encountered with equipment constructed from kits are solder bridges between adjacent IC pins and defects in etching resulting in shorts between adjacent conductors. In many cases, visually inspecting the boards for such problems can save a great deal of troubleshooting time. Also, it will pay to recheck the orientation of all integrated circuits and diodes, as it is very easy to make a mistake during assembly.

The experienced owner will find the detailed discussion of the keyboard circuitry in Section IV, "Theory of Operation", a helpful guide to circuit performance. The waveform drawings accompanying the test should be particularly useful for comparison to those waveforms observed in the unit under test. In the following paragraphs, typical difficulties are listed, followed by possible causes and recommended test procedures.

CAUTION

In some of the following tests it will be necessary to operate the keyboard with the bottom cover removed. High voltage (115 or 230 V AC) will be exposed at points within the cabinet, particularly at the rear panel. Be extremely careful not to contact these points when making tests.

Symptom: Keyboard dead in both modes; does not key transmitter, sidetone oscillator or teleprinter loop

Suggested Tests:

Switch the keyboard on by rotating the volume control clockwise. If the pilot lamp does not light, check that the keyboard is plugged into a live outlet delivering 105 to 125 V AC (or 210 to 250 V AC if your unit is wired for nominal 230 volt operation – units so wired at the factory are marked with a special tag). Also check that a fuse of the proper size and rating (a 1/4-amp; AGC delayed type) is installed in the fuseholder. Check the fuse with an ohmmeter to determine whether it is blown.

If the pilot lamp does light, the trouble may be in one of the two power supplies. To check them, unplug the line cord and remove the bottom cover by removing the three screws from the rear lip and one from the bottom lip beneath the front panel. Note that the logic circuit board is attached to this cover. Pivot the cover away from the cabinet, being careful not to damage the wiring harness. The power supply voltages may be checked at the locations on the logic board indicated in Figure 6.1.

Reconnect the AC line cord and switch the keyboard on. Using an accurate AC voltmeter with its negative lead clipped to the chassis ground, measure the output of the +5 Volt supply at the position shown. It should be within ± 0.1 Volt of +5.0 Volt DC. ~~If not, refer to step 167 in Section 5.12 for adjustment instructions.~~ If the output is too high and cannot be controlled by the adjustment pot, one or more of the regulator components may be defective. Refer to the schematic diagram shown in Figure 8.15. Check especially for a shorted pass transistor (Q201) or an open adjustment pot (P201).

If there is no output voltage, or if the voltage is too low, the transformer (T301) or rectifier diodes may be defective. Use the meter check for voltages at the primary and secondary of the transformer. Also check for shorts across the supply output at other points in the keyboard – on the circuit boards and in the wiring harness. It is possible to check for shorts or overloads on the two other circuit boards by disconnecting the edge connectors from each one in turn, observing whether the voltage returns to its correct value. Be sure to unplug the keyboard while the connections are being changed. Note that unplugging the power supply board will disable the supply.

Measure the -12 Volt supply at the point shown in Figure 6.1. It should read between -10.5 and -13.5 Volt. If the output is more negative than -13.5 Volt, the pass transistor (Q205) may be shorted or the zener diodes (D202 and D203) may be open. If no voltage is present or if the voltage is too low, check for a defective transformer (T302), blown diode or shorted capacitor. As before, the other circuit boards can be disconnected one at a time to see whether the voltage returns to normal.

If both supplies are functioning properly, set the MODE switch to 60 WPM or to MORSE and check the timing signals. Using an oscilloscope, observe the waveform at the point marked HØ in the diagram. It should be a squarewave with a frequency of approximately 23 kHz generated by the timing circuitry shown in Figure 8.8. If it is not present, the crystal, the oscillator circuit (IC-29), the control gate (parts of IC-35 and IC-30), or one of the two divide-by-16 circuits (IC's-38 and 39) may be defective. The oscillator output, at a frequency of about 6 MHz, should be observable at pin 12 of IC-29 and at pin 4 of IC-30, assuming that the oscilloscope has a vertical amplifier bandwidth of at least 6 MHz.

If the oscillator is working but the HØ clock signal is not present, check the VHØ clock waveform at the point indicated in Figure 6.1. It should be a squarewave with a frequency of about 372 kHz. If present, the difficulty is in the second divider (IC-38).

Once it has been determined that the power supplies and timing circuits are functioning properly, the next point to check is the output of the shift register, shown in Figure 8.6. Connect an oscilloscope to pin 10 of IC-10, the output of the last stage of the shift register, designated as "shift register output" in Figure 6.1. Be careful not to short to adjacent pins or conductors.

When the keyboard is idling, the shift register output should be "low" – less than 0.8 Volt. Now set the keyboard to the 60 WPM mode and press the "F" key. A series of mark and space pulses should be produced, as illustrated by the bottom trace in Figure 4.2 (page 24). The space pulses should be +2.4 Volt or greater. If the logic state of this output does not change, the keyencoder, ROM, buffer, shift register, or the associated control circuits is not operating properly. To conduct more extensive testing, press the QBF key – a long string of pulses should result (RTTY mode only).

If the shift register output is satisfactory, the difficulty must either be a result of incorrect connection to the external equipment (RTTY loop and CW transmitter) or must result from a failure of both the RTTY encoder and loop interface circuit (Figure 8.7) and the Morse circuitry, consisting of the Morse character generator (Figure 8.10) and the Morse output control (Figure 8.11).

Symptom: Keyboard will not operate at any RTTY speed; O.K. in Morse mode

Suggested Tests:

Since the keyboard operates in the Morse mode, it may be assumed that the power supplies are operating normally. The 60 WPM oscillator, its control gate, and the first two divide-by-16 counters in the timing chain must also be working properly.

First, determine whether the external RTTY loop is in the mark (current flowing) or space (current interrupted) state. If in the mark state, press the keyboard BREAK key. If the loop connections are correct and if the Loop interface circuitry (Figure 8.7) is operating properly, the loop current will be interrupted. If not recheck the loop connections; then check for a shorted switching transistor (Q2), diode (D7) or capacitor (C301).

If the loop circuit remains in the space state, check the waveform at the VHØ line (indicated in Figure 6.1). It should be a squarewave of about 400 kHz. If this signal is not present, the switching transistor (Q2) cannot be driven into conduction. Check the oscillator, control gate, and first divider circuits in the RTTY timing chain (Figure 8.8).

The RTTY control and decoding circuit (described in Section 4.7 and illustrated in Figure 8.5) is also unique to the RTTY mode and should be checked if the keyboard fails in the RTTY mode only. Use the waveforms in Section IV for comparison to those observed in the unit under test.

Symptom: Keyboard fails to operate at one RTTY speed; O.K. at other speeds and in the Morse Mode

Suggested Test:

This failure will most likely be caused by a malfunction of one of the oscillators. Referring to Figure 8.8 for pin connections, check the output of each oscillator with an oscilloscope or wavemeter. The oscillator using crystal X1 is used for 60 WPM operation, X2 for 66 WPM, X3 for 75 WPM, and X4 for 100 WPM. Set the MODE switch to the malfunctioning speed and check the oscillator signal after it has passed through the appropriate control gate for that speed. If a defective oscillator circuit is discovered, it is possible to substitute the crystal from one of the working oscillators. In this way one can determine whether the crystal or the oscillator IC is at fault.

Symptom: Keyboard fails to operate in Morse mode; O.K. at all RTTY speeds

Suggested Test:

First, recheck the connections to the transmitter being keyed. If these are correct, the difficulty will most likely be found in the Morse character generator (Figure 8.10) or the Morse output control (Figure 8.11). The performance of the latter circuit may be checked by pressing the BREAK key. With the transmitter in the "key open" condition, pressing the BREAK key should close the circuit, putting the transmitter into the "key closed" condition and should key the sidetone oscillator. If it does not, the switching transistor (Q5) may be open or one of the external connections to the output jack may be incorrect.

If the transmitter remains locked in the "key closed" condition, check for a short or reversed polarity of the connections to the transmitter. If they are satisfactory, check for a shorted switching transistor (Q5), protection diode (D10), or bypass capacitor (C302 and C303).

Symptom: Keyboard produces incorrect characters or character codes

Suggested Tests:

Since the elements which determine the character codes are built into the encoder and ROM integrated circuits at the time of manufacture, it is unlikely that they would cause transmission errors. Much more probable is that one or more of the diodes in the memory matrix for the HERE IS sequencer (Figure 8.13) or the three-letter sequencers (Figure 8.14) is reversed or shorted. These diodes will affect the codes transmitted even when the sequencers are not active, since they are connected in parallel with the ASCII output lines from the keyencoder.

It is often possible to determine which diode is at fault by comparing the ASCII code for the character that should be transmitted with that for the character which actually is transmitted. The ASCII codes are given in Table 4.2.

Symptom: HERE IS sequencer or three-letter sequencer produce incorrect codes

Suggested Tests:

A common problem which may cause the automatic sequencers to produce incorrect code patterns is improper programming (diode placement) of the memory matrix. Refer to Section V for programming instructions. An open-circuit diode or a missing diode will also cause transmission of an incorrect code for one character.

Symptom: Keyboard sends all dots in Morse mode and all blanks in RTTY mode

Suggested Tests:

This failure mode indicates that the data buses carrying ASCII character codes from the keyswitch circuit board to the logic circuit board are interrupted. An improperly installed edge connector is one possible cause; a defective or incorrectly installed buffer memory option card is another.

Symptom: One or more keys fails to produce an output

Suggested Tests:

Check for a shorted or open keyswitch. The switches must be disconnected from the circuit before they can be checked. Rather than removing the entire keyswitch module, it is more satisfactory to break the conductor path to the non-grounded switch terminal with a scribe. Once the switch operation has been checked with an ohmmeter, the path may be restored by laying a small piece of bare tinned wire across the break and soldering it in place.

Test points for the Keyswitch circuit board and Power Supply circuit board are shown in Figures 6.2 and 6.3, respectively. Table 6.1, located on the same fold-out as Figure 6.1, gives the location on the logic circuit board of the many different waveforms discussed in the text. Integrated circuit designator numbers are printed on the circuit board. Pin 1 of each IC is indicated by a "flag".

Tables 6.2 and 6.3 show the signals or voltages present at the three edge connectors. A complete wiring list for the wire harness is presented in Table 6.4. Wire colors are assigned only for those wires that connect to panel mounted components. Wires that only connect between circuit board edge connectors are not assigned specific colors and are generally the same color in a given harness.

The IC pin numbers for ground and power connections are shown in Table 6.5.

Table 6.1 Test Points - Logic Circuit Board

<u>Waveform</u>	<u>IC</u>	<u>Pin</u>	<u>Waveform</u>	<u>IC</u>	<u>Pin</u>
Resume ID	I1	6	100 WPM Osc.	I24	4
Buffer Full	I1	5	Letters Case	I25	3, 4
Buffer Read	I1	1, 13	Figures Case	I25	2, 6
Load Buffer	I2	9	RTTY Clock	I27	1, 12
Ready	I3	12	(Gate Output)	I28	8
Enable	I3	4	75 WPM Osc.	I29	2
D5	I4	9	66 WPM Osc.	I29	6
D4	I4	10	60 WPM & Morse Osc.	I29	12
D3	I4	15	Break	I30	6
D2	I4	16	M/R	I30	8
D1	I5	9	$\overline{\text{M/R}}$	I30	9
D7	I5	10	$\overline{0}$	I31	1
D6	I5	15	$\overline{1}$	I31	2
DØ	I5	16	$\overline{2}$	I31	3
Morse Shift	I8	10	$\overline{3}$	I31	4
Shift Register	I10	10	$\overline{4}$	I31	5
Morse End	I11	1	(Gate Output)	I33	6
RTTY Tone	I13	1	$\overline{\text{C} = 0 \vee 1}$	I34	6
Morse Clock	I14	6	$\overline{\text{C} = 6 \vee 7}$	I34	12
RTTY Shift	I14	8	Ø	I36	11
Morse Start	I15	5	HØ	I38	11
RTTY Start	I15	8	VHØ	I39	11
RTTY Start	I15	9	$\overline{\text{CQ Start}}$	I41	1
RTTY Load	I16	3	$\overline{\text{AUX Start}}$	I41	3
Morse End	I17	2, 4	"HERE IS" Active	I41	10
Morse Character	I18	6	3-Letter Group Active	I44	8
RTTY Load	I19	8	QBF Active	I51	8
DASH	I22	8	$\overline{\text{ID Active}}$	I53	8
Insert Case Code	I22	5	$\overline{\text{Ready ID}}$	I53	11
$\overline{\text{DOT}}$	I23	8	ID Ready	I54	13
DOT	I23	9			

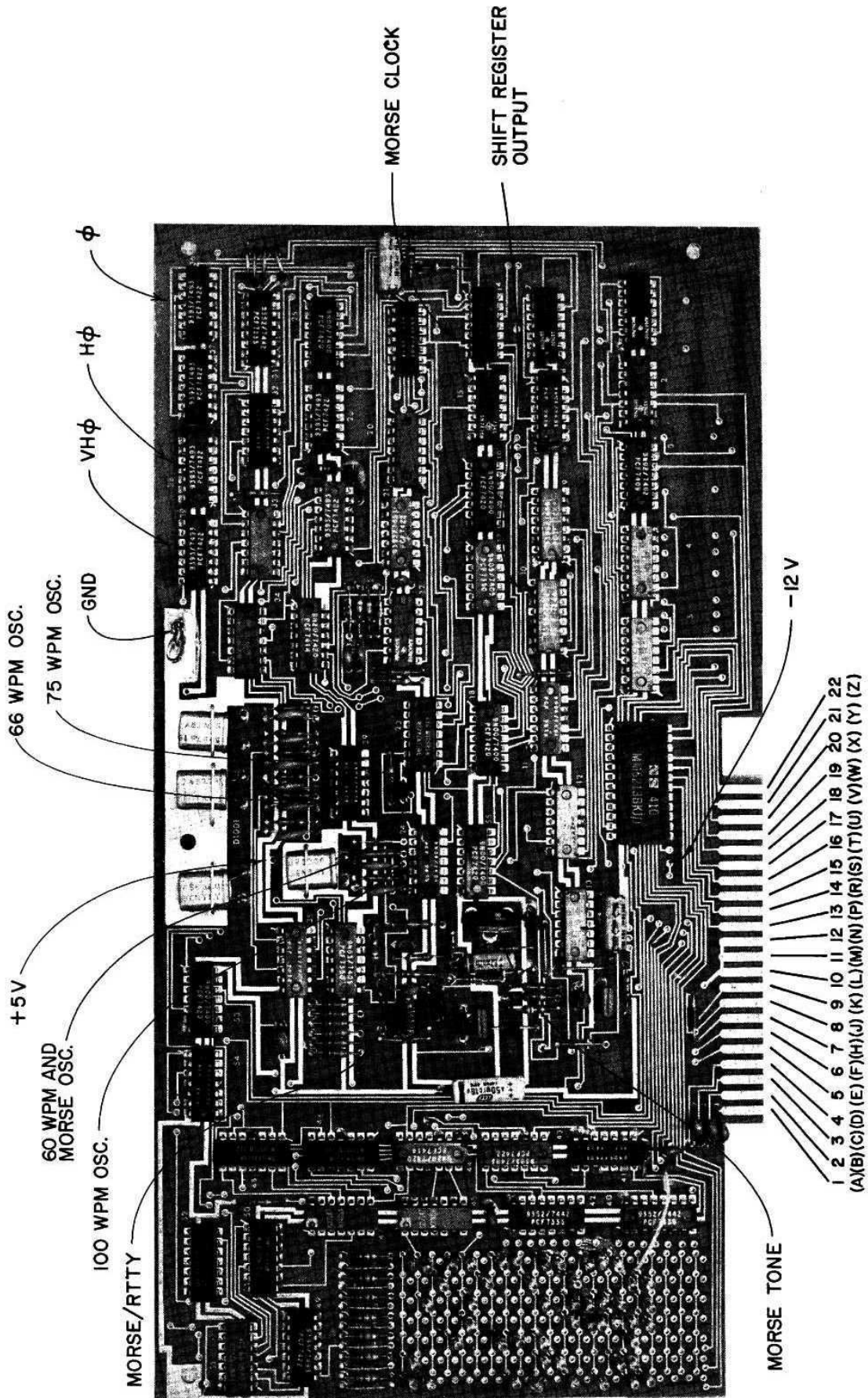

Figure 6.1 Logic Circuit Board Test Points

Figure 6.1 Logic Circuit Board Test Points

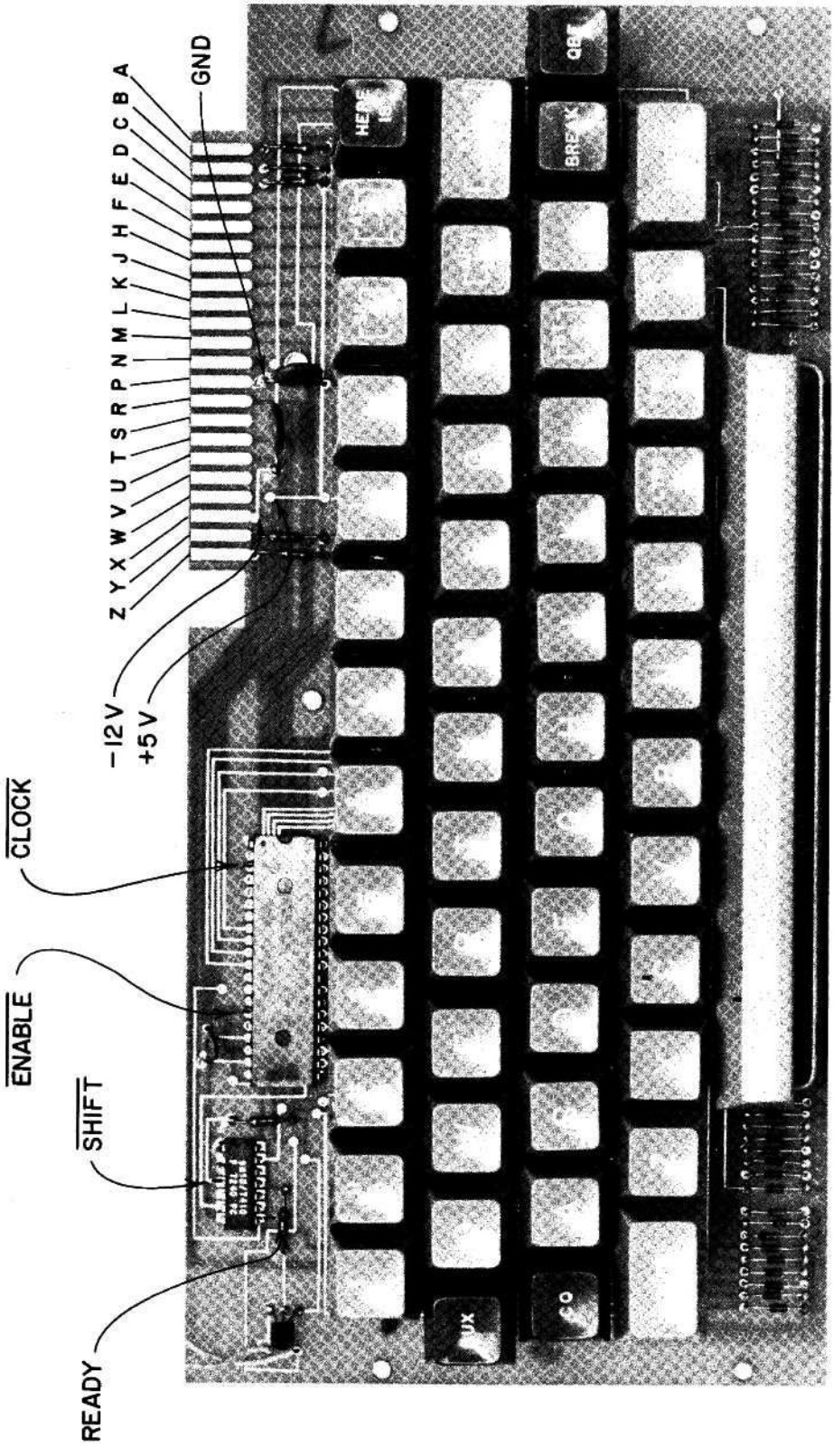

Figure 6.2 Keyswitch Circuit Board Test Points

Figure 6.2 Keyswitch Circuit Board Test Points

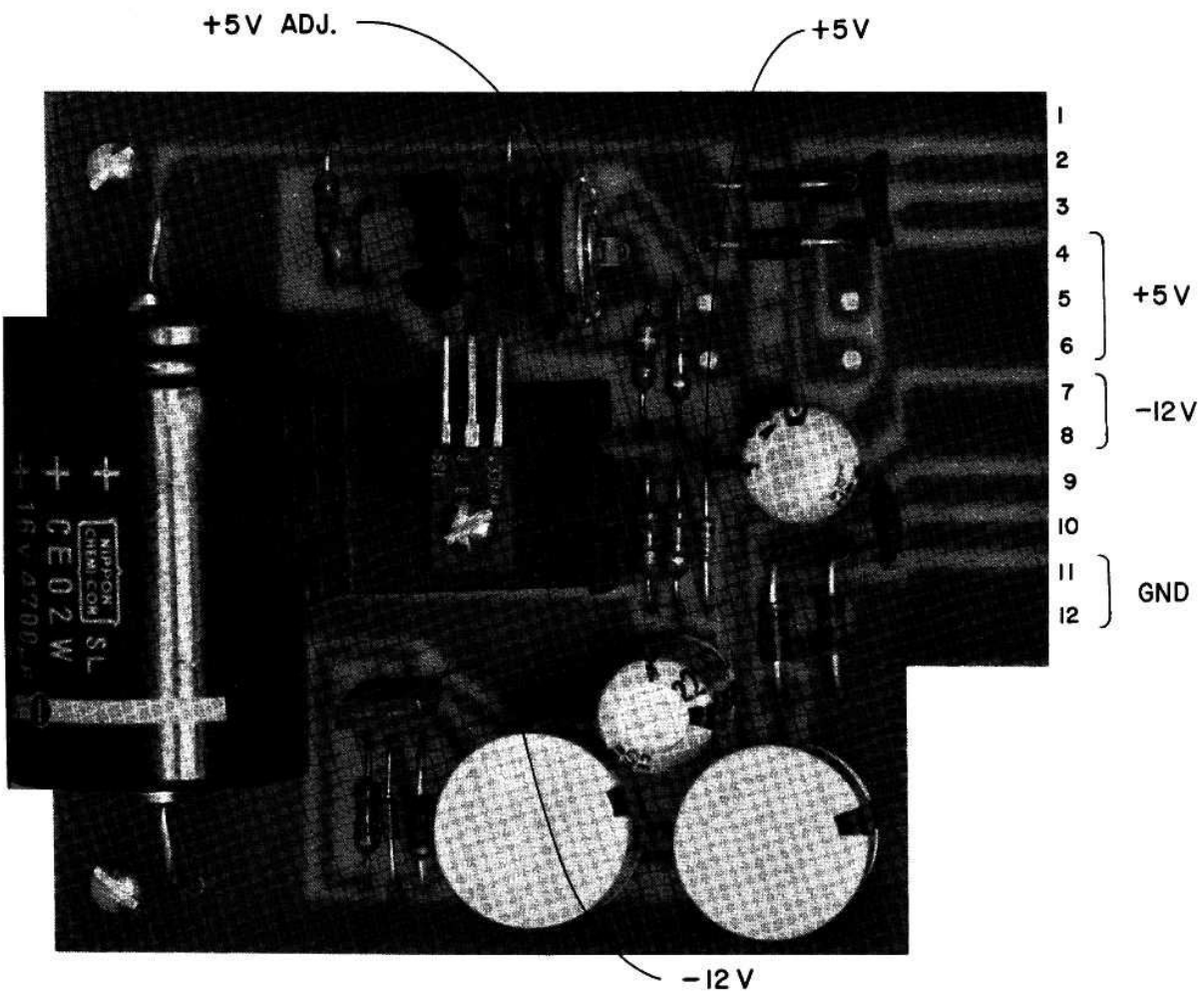

Figure 6.3 Power Supply Circuit Board Test Points

Table 6.2 DKB Logic Board Connector (J305)

A	+5 Volt	1	$\overline{\text{QBF Start}}$
B	66 WPM	2	$\overline{\text{HERE IS Start}}$
C	75 WPM	3	$\overline{\text{AUX Start}}$
D	100 WPM	4	$\overline{\text{CQ Start}}$
E	60 WPM	5	– Loop out (ring)
F	$\overline{\text{Break}}$	6	–12 Volt
H	Morse ($\overline{\text{M/R}}$)	7	GRID BLOCK
J	+ Loop out (tip)	8	CATHODE
K	Ground	9	VOLUME
L	RTTY EOL light	10	Ground
M	WEIGHT (switch common)	11	Ground
N	$\overline{\text{ID Active}}$ (to J of buffer)	12	Ground
P	not used	13	A6
R	not used	14	A5
S	not used	15	A4
T	not used	16	A3
U	1	17	A0
V	Speed pot J	18	A1
W	Weight (H)	19	A2
X	Weight (N)	20	$\overline{\text{Enable}}$
Y	Weight (L)	21	Ready
Z	Weight (VL)	22	$\overline{\text{Clock}}$

Table 6.3 DKB Keyboard Connector and DKB Power Supply

<u>Keyboard</u> (J306)			<u>Power Supply</u> (J307)
A	<u>QBF Start</u>	1	Transf. Cent. Tap
B	<u>HERE IS Start</u>	2	1
C	<u>BREAK</u>	3	12.6 Volt AC
D	A3	4	J
E	A8 (not used)	5	+5 Volt
F	A1	6	+5 Volt
H	A0	7	+5 Volt
J	A7 (not used)	8	-12 Volt
K	A6	9	-12 Volt
L	A5	10	1 6.3 Volt AC
M	A4	11	J
N	<u>SHIFT (to buffer)</u>	12	Ground
P	Ground		Ground
S	not used		
T	<u>Clock</u>		
U	Ready		
V	<u>Enable</u>		
W	+5 Volt		
X	-12 Volt		
Y	<u>CQ Start</u>		
Z	<u>AUX Start</u>		

Table 6.4 DKB-2010 Wire List

DKB 2010 WIRING LIST				DKB 2010 WIRING LIST (continued)				DKB 2010 WIRING LIST (continued)			
FROM	TO	COLOR	FMS	FROM	TO	COLOR	FMS	FROM	TO	COLOR	FMS
J305-22	J306-T	--	Clock	J305-J	S301-8	Blue *	Loop	J302	J303	Black	Grnd
J305-2	S302-3	Violet	Height	J305-5	S301-7	Violet *	Loop	J303	J307-11	Black	Grnd
J305-21	J306-U	--	Ready	J305-H	S301-2	Orange	Function	P302	J307-8	Yellow	-12
J305-Y	S302-2	Green	Height	J305-B	J306-S	--	M/R	P302	SP301	Gray	Speaker
J305-20	J306-V	--	Emble	J305-6	J307-7	Yellow	-12 VDC	P302	BS301	Green *	A.C.
J305-X	S302-1	Gray	Height	J305-F	J306-C	--	Break	P302	BS301	Green *	PR
J305-19	J306-R	--	A3	J305-E	S301	White	RTY Speed	P302	X-2	Green *	Switch
J305-W	S302-12	Brown	Height	J305-4	J306-Y	--	CQ Start	BR301	X-2	Yellow *	A.C.
J305-18	J306-F	--	A2	J305-D	S301	Green	RTY Speed	BR301	J307-1	Big Black	
J305-Y	P301-1	White	Morse Speed	J305-3	J306-Z	--	Aux Start	X-1	J307-2	Big Yellow	
J305-U	P301-2&3	Green	Morse Speed	J305-C	S301-B	Gray	RTY Speed	X-1	J307-3	Big Green	
J305-17	J306-H	--	A1	J305-2	J306-B	--	Morse Start	SP301	J307-8	Yellow	-12
J305-16	J306-D	--	A4	J305-1	S301-4	Brown	RTY Speed	SP301	J307-11	Black	Grnd
J305-15	J306-M	--	A5	J305-A	J306-A	--	QRF Start	J307-1	J307-12	Big Black	
J305-14	J306-L	--	A6	J305-A	J307-4	Big Red	+5	J305-N	J306-J	--	ID Active
J305-13	J306-K	--	A7	J305-P	J305-12	Big Black	Grnd				
J305-12	J307-12	Big Black	Grnd	J305-V	J305-A	Red	+5				
J305-11	J305-K	Black	Grnd	J306-X	J307-7	Yellow	-12				
J305-10	S301-1	Black	Grnd	J306-K	S302-11	Yellow	-12				
J305-L	S302-10	White	End of Line	J305-M	S302	Orange	Morse Switch				
J305-9	P302-3	Brown	Audio	S301	J301	Blue *	Loop				
J305-8	J302-3	Blue *	Cath out	S301	J301	Violet *	Loop				
J305-7	J303-3	Violet *	Grid out	J301	J302	Black	Grnd				

Lace tightly and out to length.
All wires should be tinned.
Lace one end of each edge connector to the harness to reduce strain on the connections.

Table 6.5 Integrated Circuit Pin Numbers for Ground and Power Connections

<u>IC Type</u>	<u>Ground</u>	<u>+5 Volt</u>	<u>-12 Volt</u>
MM5213 (or MM5231)	none	12	16, 24
MM5740	2	32	18
7400	7	14	
7401	7	14	
7402	7	14	
7404	7	14	
7405	7	14	
7410	7	14	
7420	7	14	
7430	7	14	
7442	8	16	
7474	11	4	
7475	12	5	
7493	10	5	
7496	12	5	
74121	7	14	

VII. PARTS LIST (11/75 ed.)

Integrated Circuits

1	MM5213
1	MM5740
6	7400
2	7401
5	7402
6	7404
2	7405
4	7410
2	7420
1	7430
3	7442
5	7473
5	7474
2	7475
9	7493
2	7496
1	74121

Transistors

1	2N5401
2	2N5655 (or MJE340)
1	MJE370
1	MJE521
2	MPS3394 (or MPS3395 or MPS6414)
5	MPS3703 (or MPS3702 or MPS6518)

Diodes

72	1N270
4	1N4001 (or 1N4005)
2	1N4005 (only)
46	1N4148 (or 1N914)
1	1N4742

Crystals

1	5.95781 MHz
1	6.55360 MHz
1	7.45998 MHz
1	9.73066 MHz

Resistors

2	100 Ω , 1/4 Watt
2	120 Ω , 1/4 Watt
1	180 Ω , 1/4 Watt
1	220 Ω , 1/4 Watt
3	270 Ω , 1/4 Watt
1	330 Ω , 1/4 Watt
3	390 Ω , 1/4 Watt
1	470 Ω , 1/4 Watt
4	560 Ω , 1/4 Watt
26	1 k Ω , 1/4 Watt
4	1.8 k Ω , 1/4 Watt
1	2.2 k Ω , 1/4 Watt
1	2.7 k Ω , 1/4 Watt
1	3.3 k Ω , 1/4 Watt
1	4.7 k Ω , 1/4 Watt
1	8.2 k Ω , 1/4 Watt
10	10 k Ω , 1/4 Watt
1	100 k Ω , 1/2 Watt
2	500 Ω trim-pot
1	1.5 k Ω panel pot
1	500 Ω panel pot w/switch

Capacitors

8	100 pF disc ceramic
1	220 pF disc ceramic
1	390 pF disc ceramic
18	.001 μ F disc ceramic
8	.01 μ F disc ceramic
7	.1 μ F disc ceramic
1	.1 μ F / 400 V mylar
1	2.2 μ F / 16 V axial electrolytic
3	10 μ F / 16 V axial electrolytic
2	47 μ F / 16 V axial electrolytic
2	220 μ F / 16 V radial electrolytic
2	1000 μ F / 16 V radial electrolytic
1	4700 μ F / 16 V axial electrolytic

Switches and Connectors

1	2 pole, 5 position rotary switch
1	3 pole, 4 position rotary switch
1	phono jack
1	phono plug
1	6 pin female connector shell
2	6 pin male connector shell
1	3 pin female connector shell
2	3 pin male connector shell
9	male connector pins
18	female connector pins

Circuit Boards

1	Power Supply Board
1	Keyswitch Circuit Board
1	Logic Circuit Board

Transformers

1	Transformer, type A1055
1	Transformer, type 6375
1	Transformer Assembly, Audio Output including: 1 - output transformer 1 - mounting bracket

Miscellaneous Components

1	Speaker
3	Red plastic lens
1	neon lamp
2	incandescent lamps
4	knobs
1	fuseholder
1	fuse, 1/4 amp slow-blow
1	power cord strain relief
1	6 lug terminal strip
1	transistor heat sink type 6107
1	toroid core type CF102-Q1

Wire

1	3-conductor power cord
1	DKB-2010 wiring harness
1	24" length no. 22 tinned bar wire
1	36" length no. 22 hook-up wire
1	9" length no. 22 insulated sleeving
1	48" length no. 30 Strip-eze magnet wire
1	40" length no. 22 Multi-core solder
2	48" length 2-conductor shielded cable

Cabinet and Brackets

3	Angle brackets
1	Connector bracket
1	Top panel
1	Bottom panel
1	Rear panel
1	Inner right side panel
1	Inner left side panel
1	Outer right side panel
1	Outer left side panel

Hardware

2	4-40 × 1/4" round-head screws
1	4-40 × 3/8" round-head screws
4	4-40 × 1/2" round-head screws
11	4-40 × 1/2" round-head Phillips screws
14	4-40 hex nuts
7	No. 4 internal lockwashers
31	6-32 × 5/16" round-head Phillips screws
15	6-32 × 1/4" flat-head Phillips screws
3	6-32 × 1/2" round-head Phillips screws
3	6-32 × 5/8" round-head Phillips screws
2	6-32 × 3/4" round-head Phillips screws
24	6-32 hex locknuts
7	No. 6 internal lockwashers
3	No. 6, 5/8" diameter flatwashers
11	No. 6 nylon washer
1	1/4" internal lockwasher
1	3/8" flatwasher
2	4-40 × 1/2" threaded spacers
4	6-32 × 1/4" threaded spacers
5	6-32 × 3/4" threaded spacers
4	Rubber feet
1	No. 6 ground lug
1	6-32 Thumb-nut
1	Manual, DKB-2010

Keyboard Parts

- 53 Keyswitches
- 53 Return Springs
- 52 Spring Retainer Washers
- 1 Space Bar Hardware Set, consisting of:
 - 2 Space-bar plungers
 - 2 Space-bar guides
 - 2 No. 4 × 1/4" screws
 - 1 Space-bar adapter
 - 1 Space-bar torsion bar
- 1 Keytop Set, consisting of:
 - 1 Space-bar Keytop
 - 1 Blank Keytop
 - 2 Shift Keytops
 - 1 "AUX" Keytop
 - 1 "CQ" Keytop
 - 1 "HERE IS" Keytop
 - 1 "KN / RETURN" Keytop
 - 1 "BRK" Keytop
 - 1 "QBF" Keytop
 - 1 "BT / ;" Keytop
 - 1 "AR / LF" Keytop
 - 1 "AS / -" Keytop
 - 1 "BELL / :" Keytop
 - 1 "? / "" Keytop
 - 1 "FIGS / ." Keytop
 - 1 "LTRS / ," Keytop
 - 10 Number set keytops, "1 / !" through "0"
 - 26 Letter set keytops, "A" through "Z"
- 3 Keyboard stiffener bars, insulated

VIII. DIAGRAMS

In this section you will find the schematic diagrams and layout drawings for the DKB-2010 keyboard, as listed below.

An explanation of the labels and codes used in the schematic diagrams may be found in Section 4.3. The drawing conventions are depicted in Figure 8.2.

- Figure 8.1: DIG-2010 Block Diagram
- Figure 8.2: Drawing Conventions
- Figure 8.3: Keyboard Encoder
- Figure 8.4: ROM Code Converter and Buffer Control
- Figure 8.5: RTTY Control and Decoder

- Figure 8.6: Shift Register Control
- Figure 8.7: RTTY Encoder and Loop Interface
- Figure 8.8: RTTY Timing Chain
- Figure 8.9: RTTY Character Counter
- Figure 8.10: Morse Character Generator

- Figure 8.11: Morse Output Control
- Figure 8.12: Quick Brown Fox Generator and ID Control
- Figure 8.13: Identifier
- Figure 8.14: Three-Character Sequencers
- Figure 8.15: Power Supply Module

- Figure 8.16: Power Supply Board Component Layout
- Figure 8.17: Keyboard Circuit Board Component Layout
- Figure 8.18: Keytop Positions
- Figure 8.19: Main Logic Board Component Layout - IC's
- Figure 8.20: Main Logic Board Component Layout - Small Parts

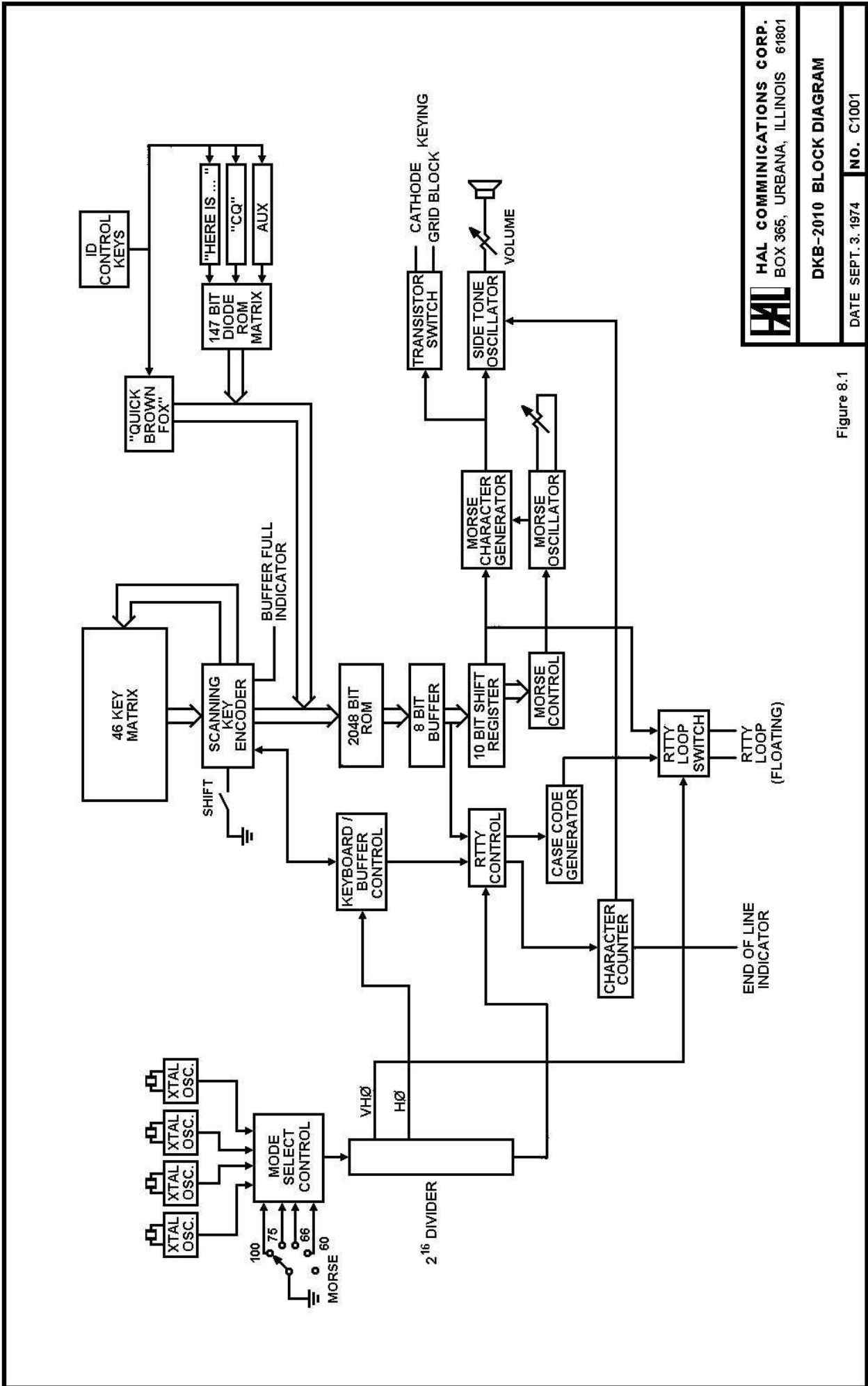

HAL
HAL COMMUNICATIONS CORP.
 BOX 365, URBANA, ILLINOIS 61801

DKB-2010 BLOCK DIAGRAM

DATE SEPT. 3, 1974 NO. C1001

Figure 8.1

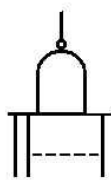

NAND
(OUTPUT = 1 WHEN
ANY INPUT = 0)
7400, 7410, 7420, 7430



NOR
(OUTPUT = 0 WHEN
ANY INPUT = 1)
7402

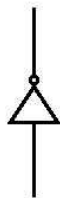

NOT
7404

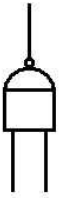
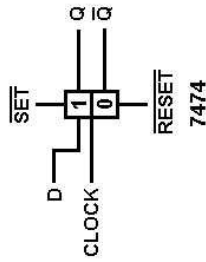

NAND
OPEN COLLECTOR
7401

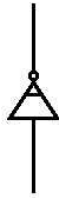

NOT
OPEN COLLECTOR
7405

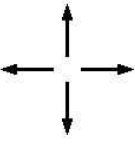
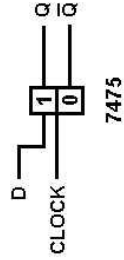
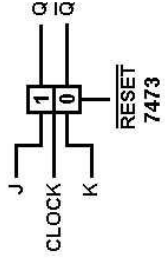

+5 VOLT CONNECTION
UNLESS LABELED OTHERWISE



GROUND CONNECTION
(0 VOLT)



CONNECTION

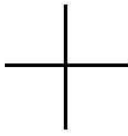

NO CONNECTION

ID ACTIVE
8.6-C5

CONNECTION FROM
FIGURE 8.6, AREA C5
LABELED "ID ACTIVE"



BOARD CONNECTION

Figure 8.2

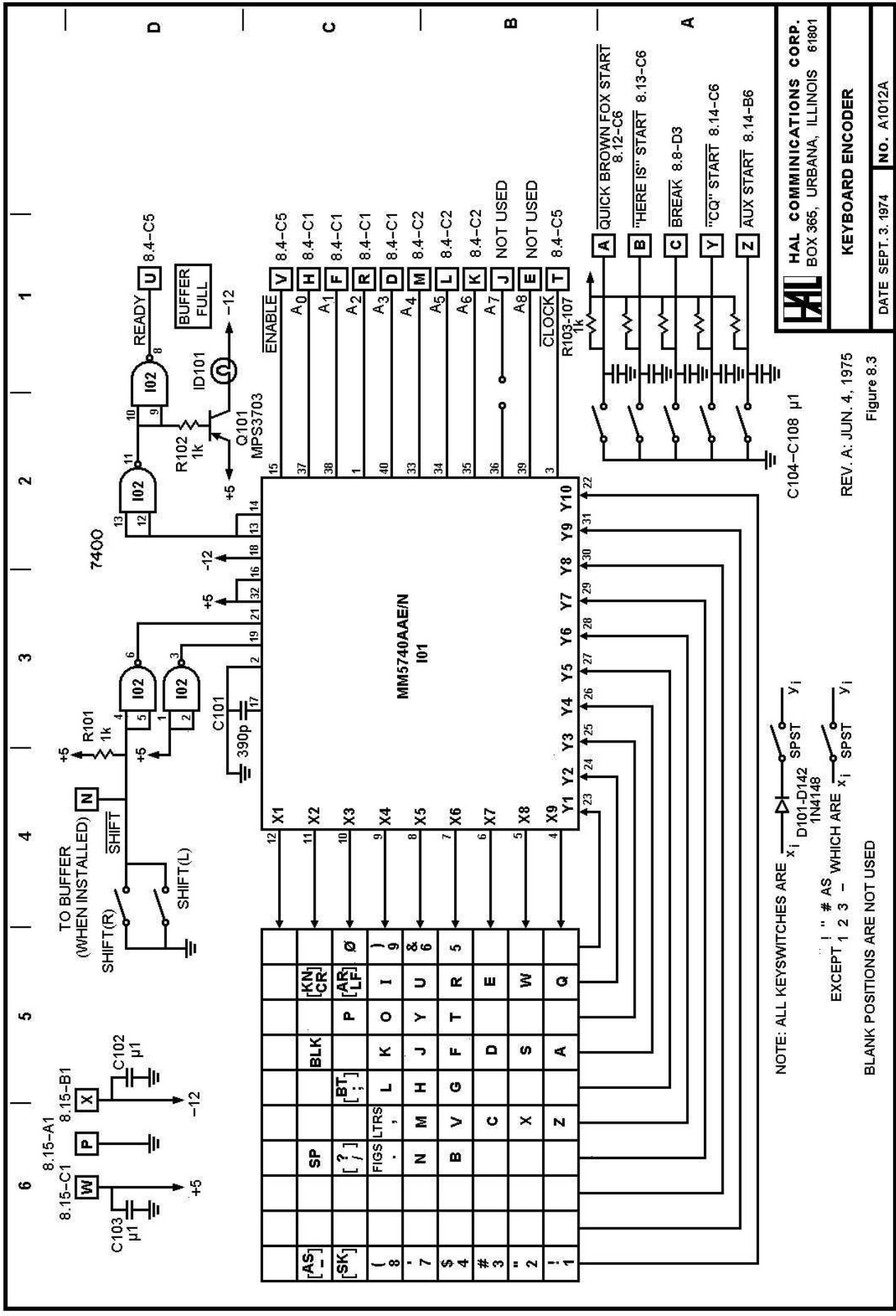



HAL COMMUNICATIONS CORP.
 BOX 366, URBANA, ILLINOIS 61801
KEYBOARD ENCODER
 DATE SEPT. 3, 1974 NO. A1012A

REV. A. JUN. 4, 1975
Figure 8.3

NOTE: ALL KEYSWITCHES ARE x_i D101-D142 SPST y_i
 1N4148
 EXCEPT 1 2 3 - WHICH ARE x_i SPST y_i
 BLANK POSITIONS ARE NOT USED

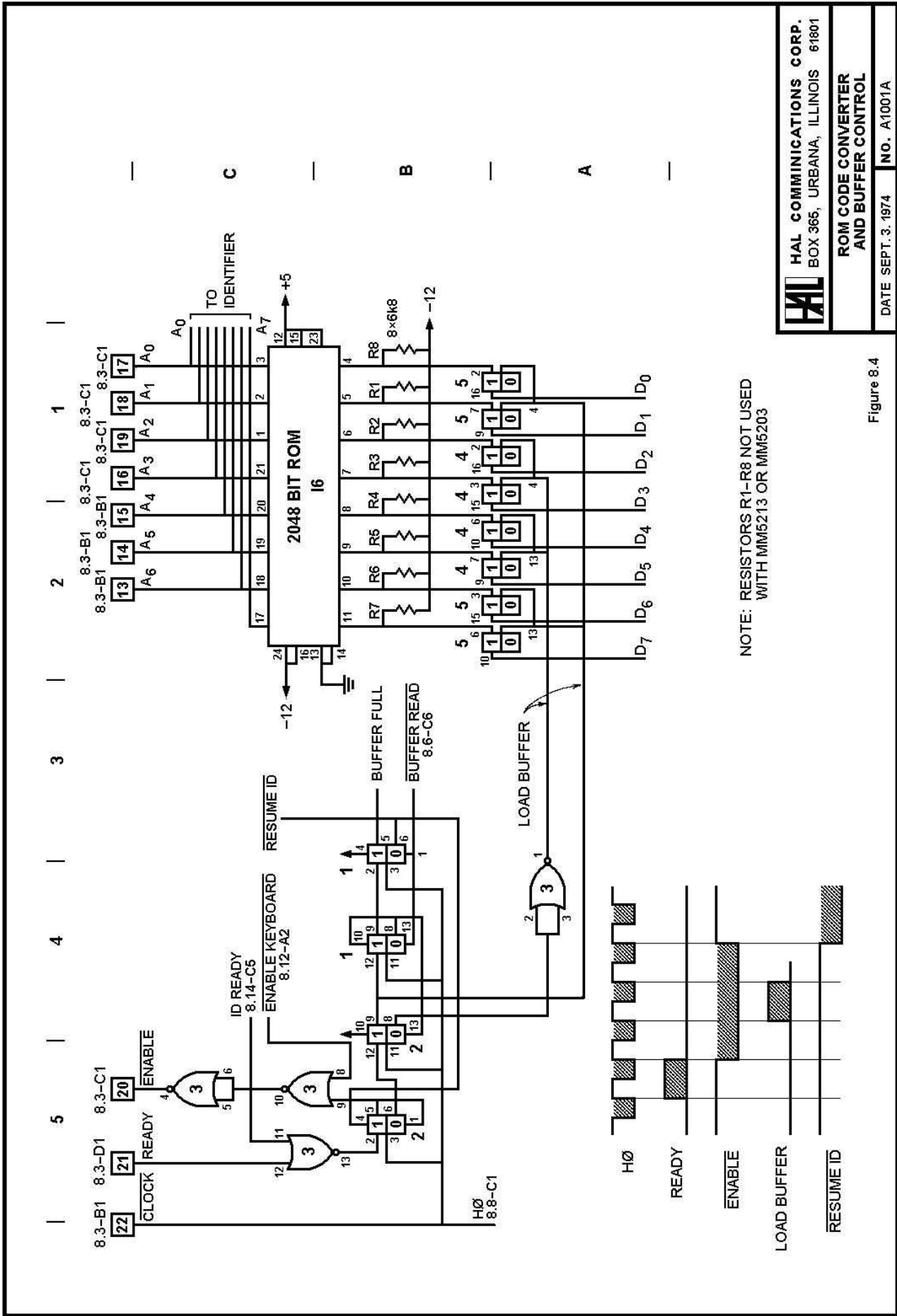
Part List:	Figure 8.3:	<u>Keyboard Encoder</u>
C101		390 pF Disc Ceramic Capacitor
C102 - C108		0.1 μ F Disc Ceramic Capacitor (16 Volt)
R101 - R107		1 k Ω , 1/4 Watt Resistor
Q101		MPS3702, MPS3703, or MPS6518 PNP Transistor
D101 - D138		1N4148 Silicon Diode
I101		MM5740AAA/N Integrated Circuit
I102		7410 Integrated Circuit
ID101		24 V / 40 mA Incandescent Lamp
S101 - S153		Controls Research "BI-PAC" Keyswitch



HAL HAL COMMUNICATIONS CORP.
BOX 366, URBANA, ILLINOIS 61801

ROM CODE CONVERTER
AND BUFFER CONTROL

DATE SEPT. 3, 1974 NO. A1001A

Figure 8.4

Parts List:	Figure 8.4:	<u>Buffer Control</u>
R1 - R8		6.8 k Ω , 1/4 Watt Resistor
I1, I2		7474 Integrated Circuit
I3		7402 Integrated Circuit
I4, I5		7475 Integrated Circuit
I6		MM5213/N, MM5231/N or MM5203/N

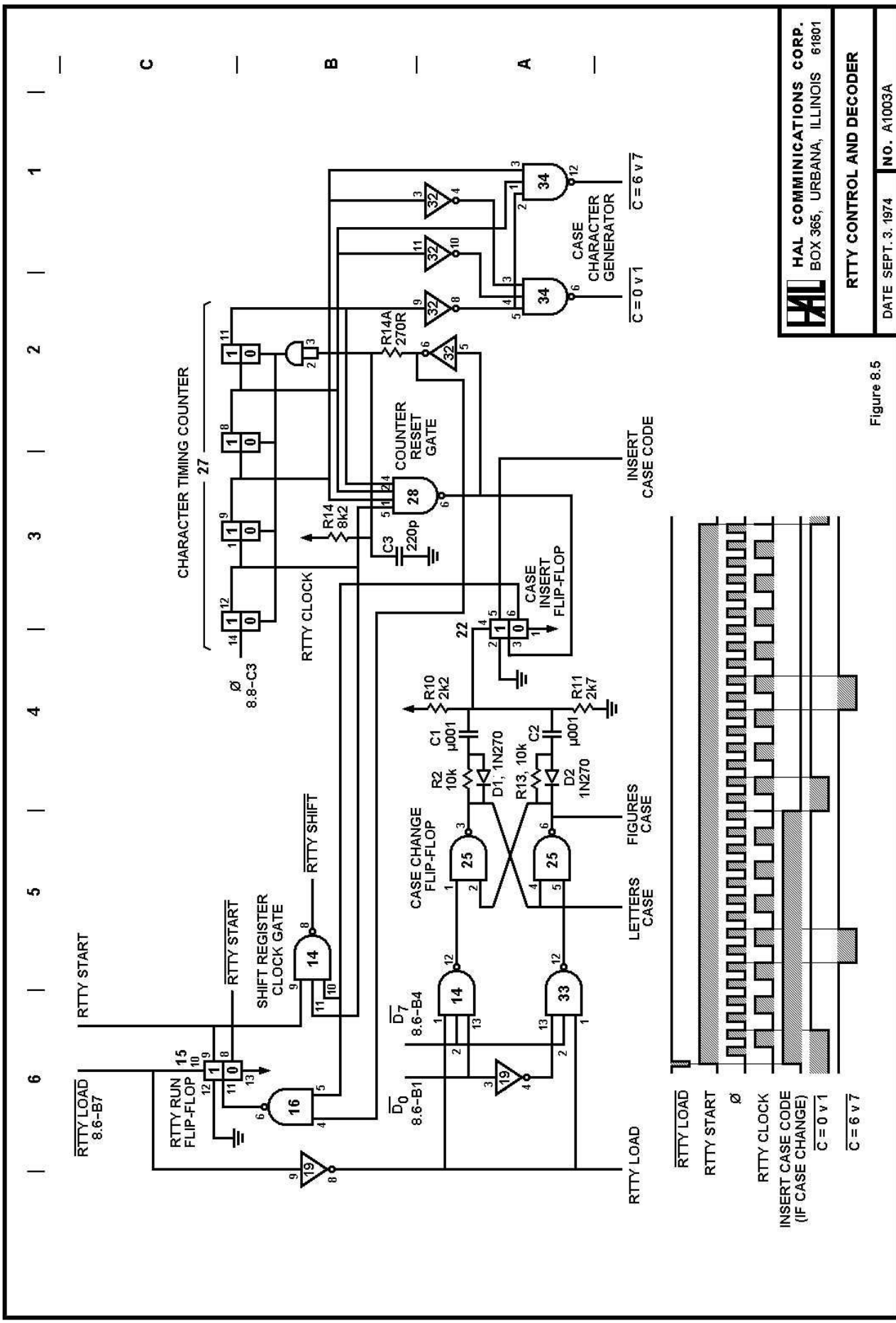

Figure 8.5

HAL HAL COMMUNICATIONS CORP.
BOX 366, URBANA, ILLINOIS 61801

RTTY CONTROL AND DECODER

DATE SEPT. 3, 1974 NO. A1003A

Parts List: Figure 8.5: RTTY Control and Decoder

C1, C2	0.001 μ F Disc Ceramic Capacitor
C3	220 pF Disc Ceramic Capacitor
R10	2.2 k Ω , 1/4 Watt Resistor
R11	2.7 k Ω , 1/4 Watt Resistor
R12, R13	10 k Ω , 1/4 Watt Resistor
R14	8.2 k Ω , 1/4 Watt Resistor
R14A	270 Ω , 1/4 Watt Resistor
D1, D2	1N270 Germanium Diode
I14, I33, I34	7410 Integrated Circuit
I16, I25	7400 Integrated Circuit
I15, I22	7474 Integrated Circuit
I19, I32	7404 Integrated Circuit
I27	7493 Integrated Circuit
I28	7420 Integrated Circuit

Parts List:	Figure 8.6:	<u>Shift Register Control</u>
R9		1 k Ω , ¼ Watt Resistor
I7		7474 Integrated Circuit
I8, I11		7402 Integrated Circuit
I9, I10		7496 Integrated Circuit
I12		7404 Integrated Circuit
I16, I18		7400 Integrated Circuit
I17		7405 Integrated Circuit

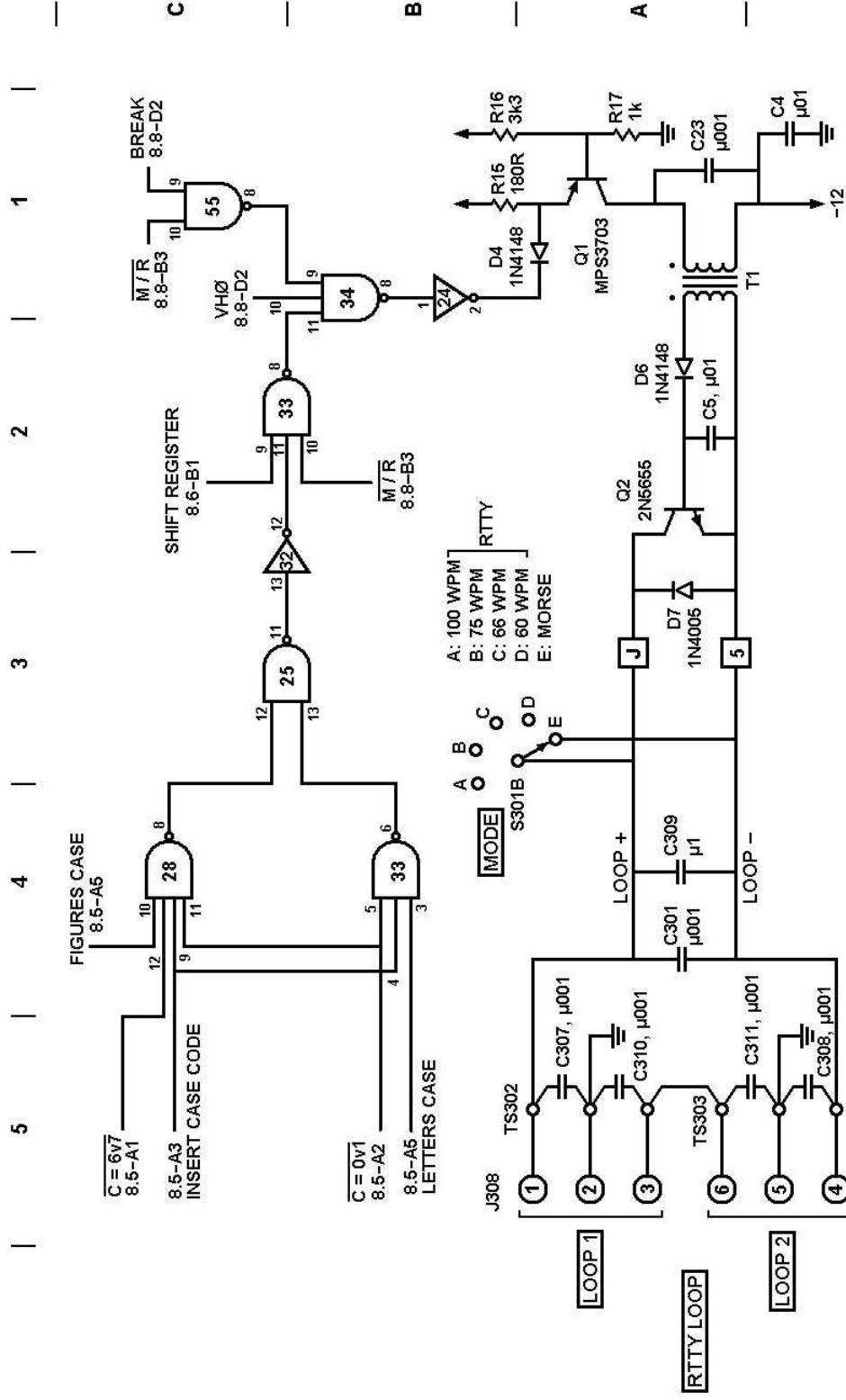

HAL HAL COMMUNICATIONS CORP.
BOX 365, URBANA, ILLINOIS 61801

DATE SEPT. 3, 1974 NO. A1004B

REV. B: JUN. 20, 1975

Figure 8.7

Parts List: Figure 8.7 RTTY Encoder and Loop Interface

C4, C5	0.01 μ F Disc Ceramic Capacitor
C23, C301, C307, C308	0.001 μ F Disc Ceramic Capacitor
C309	0.1 μ F, 400 V Mylar Capacitor
R15	180 Ω , 1/4 Watt Resistor
R16	3.3 k Ω , 1/4 Watt Resistor
R17	1 k Ω , 1/4 Watt Resistor
D4, D5, D6	1N4148 Silicon Signal Diode
D7	1N4005 Silicon Power Diode
Q1	MPS3702, MPS3703 or MPS6518 PNP Transistor
Q2	2N5655 or MJE340 NPN Transistor
I24	7404 Integrated Circuit
I25, I55	7400 Integrated Circuit
I28	7420 Integrated Circuit
I33, I34	7410 Integrated Circuit
J301	1/4" Phone Jack, 2-circuit
S301	5 position, 2 pole Rotary Switch (Mode Switch)
T1	PRI = SEC = 30 turns no. 30 Magnet Wire wound on Ferroxcube CF102-Q1 Toroidal Core

Parts List: Figure 8.8: RTTY Timing Chain

C6 - C13	100 pF Disc Ceramic Capacitor
R18, R19, R21 - R24, R33	1 k Ω , 1/4 Watt Resistor
R20	390 Ω , 1/4 Watt Resistor
R25 - R28	1.8 k Ω , 1/4 Watt Resistor
R29 - R32	560 Ω , 1/4 Watt Resistor
D8	1N270 Germanium Diode
I24, I29	7404 Integrated Circuit
I30	7405 Integrated Circuit
I35	7402 Integrated Circuit
I36 - I39	7493 Integrated Circuit
S301	5 position, 2 pole Rotary Switch (Mode Switch)
X1	5.957818 MHz Quartz Crystal
X2	6.553600 MHz Quartz Crystal
X3	7.459988 MHz Quartz Crystal
X4	9.730660 MHz Quartz Crystal

5 | 4 | 3 | 2 | 1 |

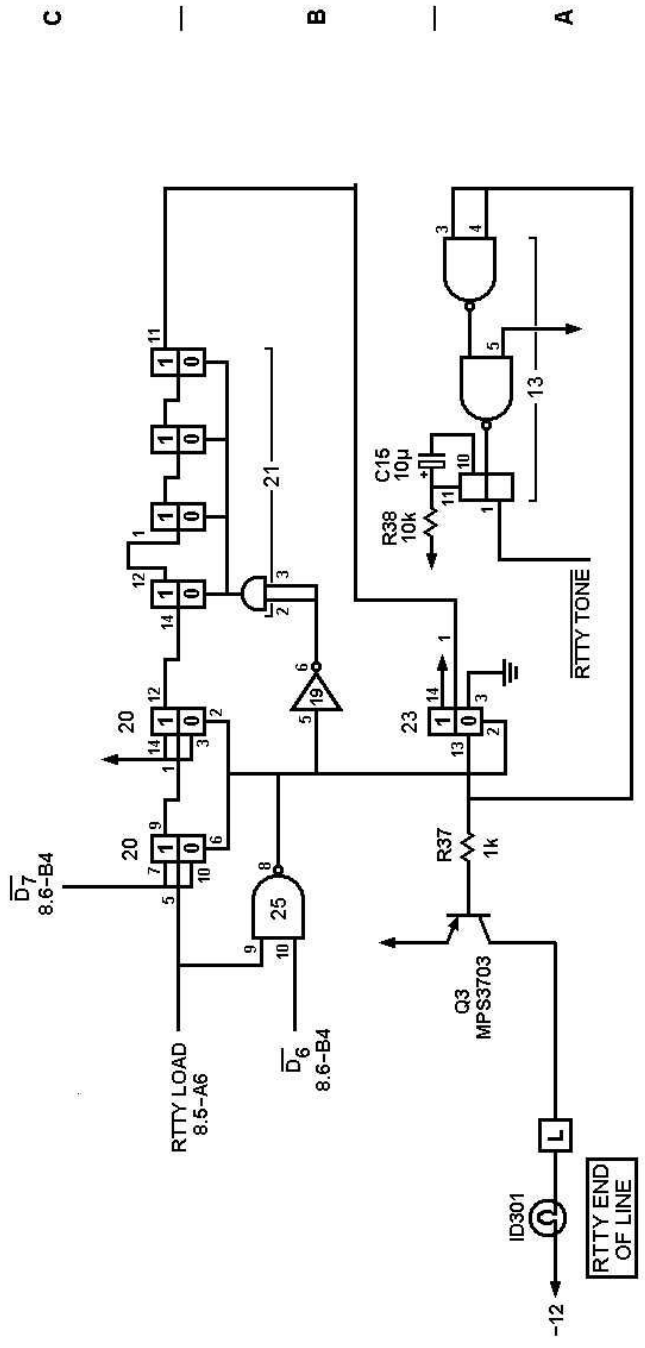

Figure 8.9

HAL HAL COMMUNICATIONS CORP.
 BOX 365, URBANA, ILLINOIS 61801

RTTY CHARACTER COUNTER
 DATE SEPT. 3. 1974 NO. A1007

Part List: Figure 8.9: RTTY Character Counter

C15	10 μ F, 16 Volt Electrolytic Capacitor
R37	1 k Ω , 1/4 Watt Resistor
R38	10 k Ω , 1/4 Watt Resistor
I13	74121 Integrated Circuit
I19	7404 Integrated Circuit
I20, I23	7473 Integrated Circuit
I21	7493 Integrated Circuit
I25	7400 Integrated Circuit
ID301	24 Volt , 40 mA Incandescent Lamp
Q3	MPS3702, MPS3703, MPS6518 PNP Transistor

Part List:	Figure 8.10	<u>Morse Character Generator</u>
C14		10 μ F, 16 Volt Electrolytic Capacitor
R35		470 Ω , 1/4 Watt Resistor
R36		330 Ω , 1/4 Watt Resistor
P301		1.5 k Ω , Reverse-Log. Taper Potentiometer
I11		7402 Integrated Circuit
I12, I19, I32		7404 Integrated Circuit
I14		7410 Integrated Circuit
I15, I22		7474 Integrated Circuit
I18		7400 Integrated Circuit
I23		7473 Integrated Circuit
I26		7493 Integrated Circuit
I31		7442 Integrated Circuit
JPR1 - JPR4		Jumper , #22 Bare Wire
S302		4 position, 3 pole Rotary Switch (Weight Switch)

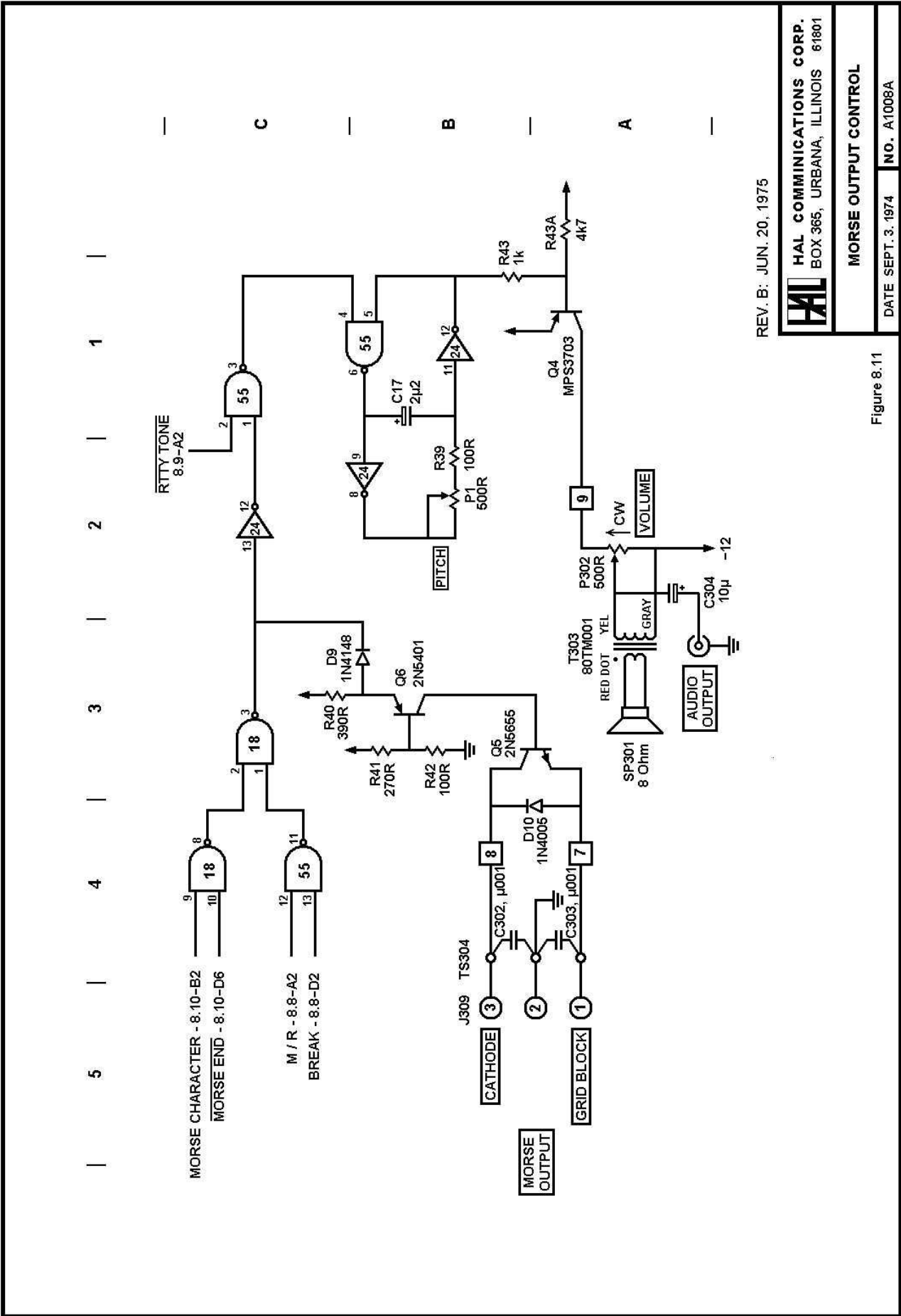

REV. B: JUN. 20, 1975

HAL HAL COMMUNICATIONS CORP.
BOX 365, URBANA, ILLINOIS 61801

MORSE OUTPUT CONTROL

DATE SEPT. 3, 1974 NO. A1008A

Figure 8.11

Parts List: Figure 8.11: Morse Output Control

C17	2.2 μ F, 16 Volt Electrolytic Capacitor
C17A	4.7 μ F, 25 Volt Electrolytic Capacitor
C302, C303	0.001 μ F Disc Ceramic Capacitor
C304	10 μ F, 16 Volt Electrolytic Capacitor
R39, R42, R43B, R43C	100 Ω , 1/4 Watt Resistor
R40	390 Ω , 1/4 Watt Resistor
R41	270 Ω , 1/4 Watt Resistor
R43	1 k Ω , 1/4 Watt Resistor
R43A	4.7 k Ω , 1/4 Watt Resistor
P1	500 Ω Trim-Pot, Vertical Mounting
P302	500 Ω Linear Potentiometer, with Switch (Volume Control)
D9	1N4148 Silicon Signal Diode
D10	1N4005 Silicon Power Diode
Q4	MPS3703 or MPS6518 PNP Transistor
Q5	2N5655 or MJE340 NPN Transistor
Q6	2N5401 PNP Transistor
I18, I55	7400 Integrated Circuit
I24	7404 Integrated Circuit
J302, J303	1/4" Phone Jack, 1-circuit with NO contact
J304	Phono Jack
SP301	2" Speaker, 8 or 25 Ω impedance

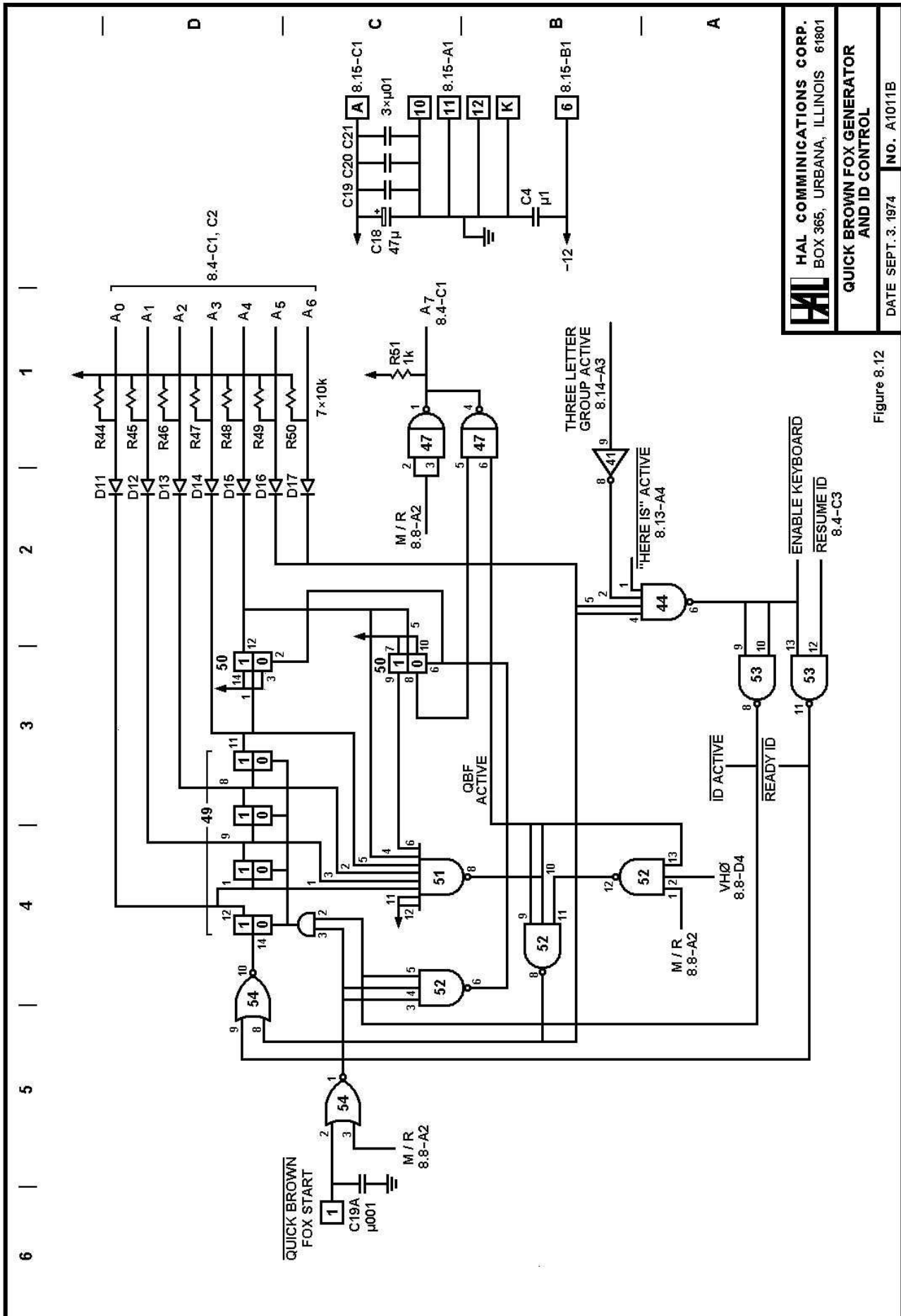

Figure 8.12

HAL HAL COMMUNICATIONS CORP.
 BOX 365, URBANA, ILLINOIS 61801

**QUICK BROWN FOX GENERATOR
 AND ID CONTROL**

DATE SEPT. 3. 1974 NO. A1011B

Parts List: Figure 8.12: Quick Brown Fox Generator and ID Control

C4	0.1 μ F Disc Ceramic Capacitor
C18	47 μ F, 16 Volt Electrolytic Capacitor
C19 - C21	0.01 μ F Disc Ceramic Capacitor
C19A	0.001 μ F Disc Ceramic Capacitor
R44 - R50	10 k Ω , 1/4 Watt Resistor
R51	1 k Ω , 1/4 Watt Resistor
D11 - D17	1N270 Germanium Diode
I41	7404 Integrated Circuit
I44	7420 Integrated Circuit
I47	7401 Integrated Circuit
I49	7493 Integrated Circuit
I50	7473 Integrated Circuit
I51	7430 Integrated Circuit
I52	7410 Integrated Circuit
I53	7400 Integrated Circuit
I54	7402 Integrated Circuit

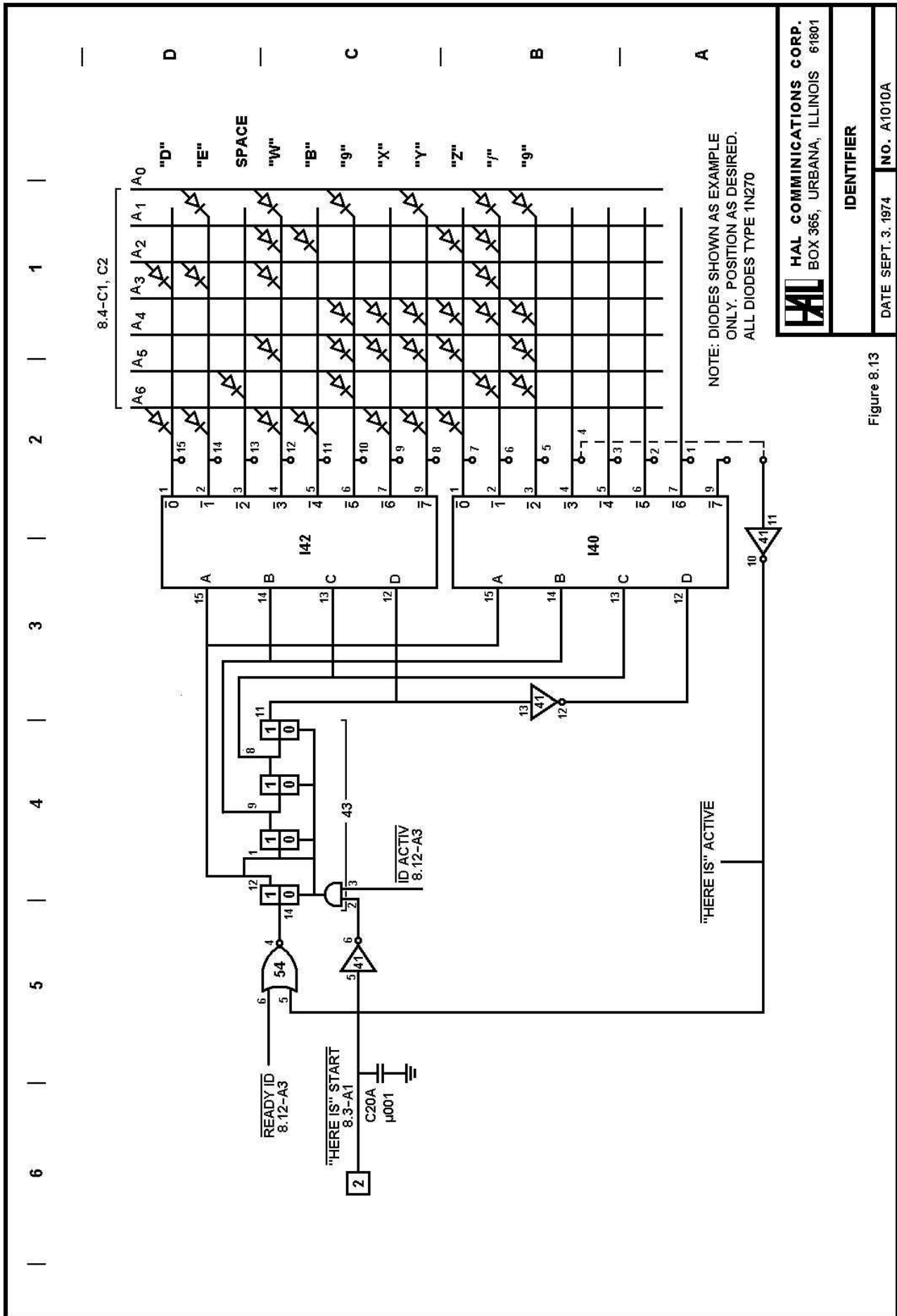

HAL HAL COMMUNICATIONS CORP.
 BOX 366, URBANA, ILLINOIS 61801

IDENTIFIER

DATE SEPT. 3, 1974 NO. A1010A

Figure 8.13

Part List: Figure 8.13: Identifier

C20A	0.001 μ F Disc Ceramic Capacitor
I40, I42	7442 Integrated Circuit
I41	7404 Integrated Circuit
I43	7493 Integrated Circuit
I54	7402 Integrated Circuit
JPR5	Jumper, #28 Insulated Wire, 1" long

6 | 5 | 4 | 3 | 2 | 1 |

8.4-C1, C2

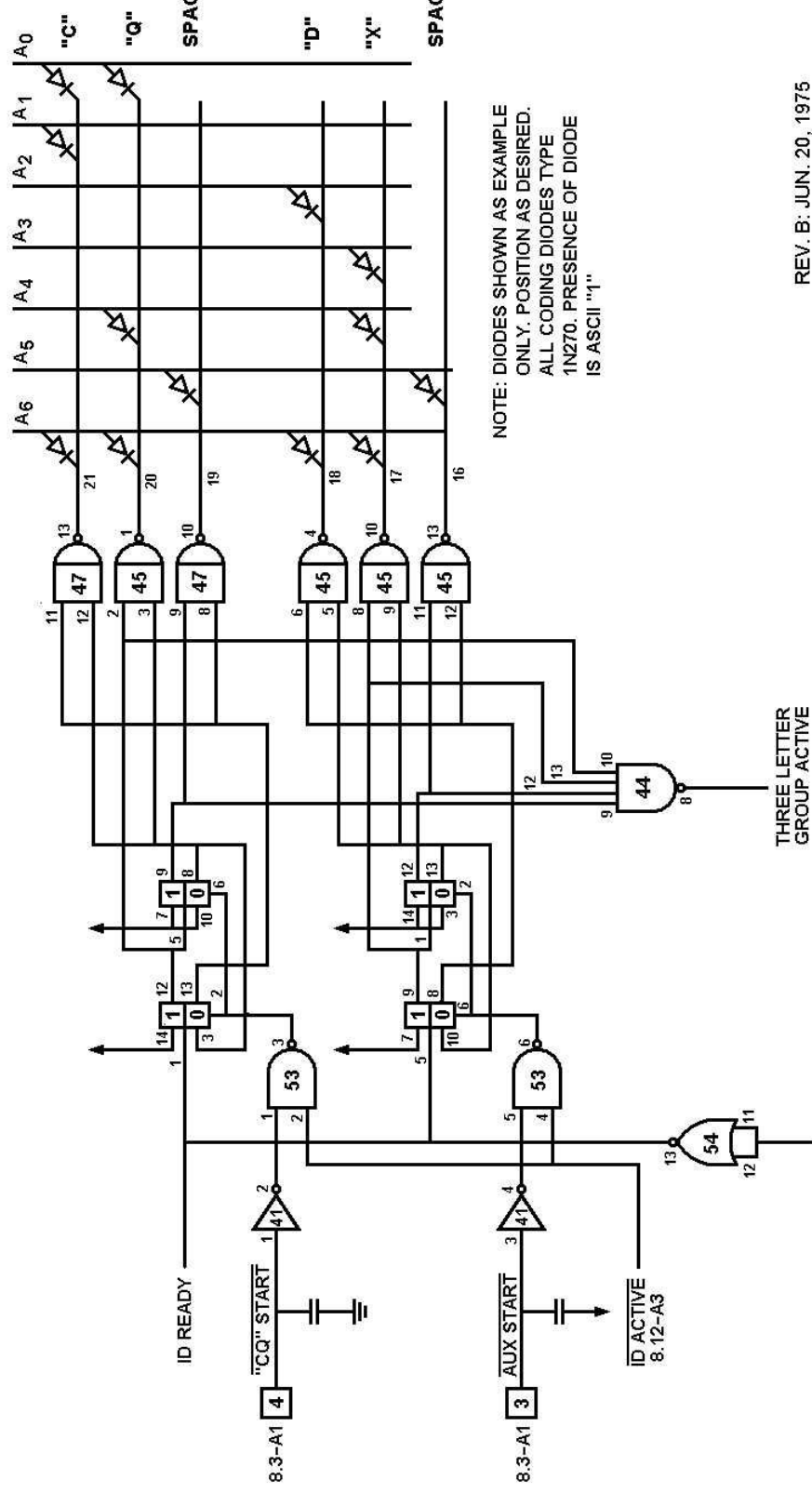

NOTE: DIODES SHOWN AS EXAMPLE ONLY. POSITION AS DESIRED. ALL CODING DIODES TYPE 1N270. PRESENCE OF DIODE IS ASCII "1".

REV. B: JUN. 20, 1975

HAL HAL COMMUNICATIONS CORP.
BOX 365, URBANA, ILLINOIS 61801

THREE - CHARACTER SEQUENCERS
DATE SEPT. 3, 1974 NO. A1009B

Figure 8.14

Part List: Figure 8.14: Three-Character Sequencer

C21A, C22A	0.001 μ F Disc Ceramic Capacitor
I41	7404 Integrated Circuit
I44	7420 Integrated Circuit
I45, 147	7401 Integrated Circuit
I46, I48	7473 Integrated Circuit
I53	7400 Integrated Circuit
I54	7402 Integrated Circuit

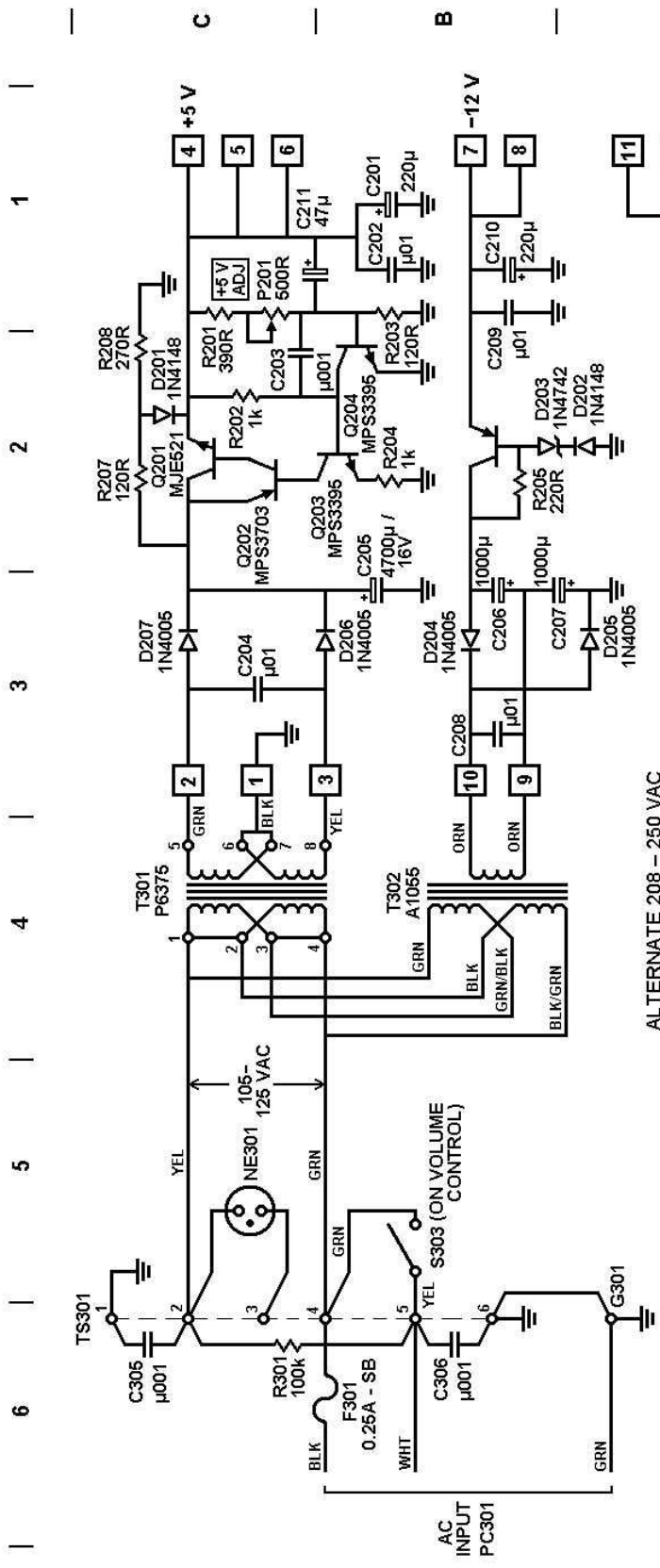

NOTE: 1. C202 AND C209 ADDED AT CONNECTOR AS NECESSARY
 2. FOR 208-250 VAC OPERATION C205 IS 10,000 μ F/12V

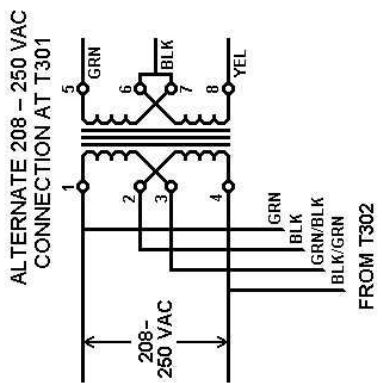

REV. A: JUN. 23, 1975

HAL HAL COMMUNICATIONS CORP.
 BOX 365, URBANA, ILLINOIS 61801

POWER SUPPLY MODULE

DATE SEPT. 3, 1974 NO. A1013A

Figure 8.15

Part List: Figure 8.15: Power Supply Module

C201, C210	220 μ F, 16 Volt Electrolytic Capacitor
C202, C204, C208, C209	0.01 μ F Disc Ceramic Capacitor
C203	0.001 μ F Disc Ceramic Capacitor
C205	4700 μ F, 16 Volt Electrolytic Capacitor
C206, C207	1000 μ F, 16 Volt Electrolytic Capacitor
C208	47 μ F, 16 Volt Electrolytic Capacitor
C305, C306	0.001 μ F, 1000 Volt Disc Ceramic Capacitor
R21	390 Ω , 1/4 Watt Resistor
R202, R204	1 k Ω , 1/4 Watt Resistor
R203, R207	120 Ω , 1/4 Watt Resistor
R205	220 Ω , 1/4 Watt Resistor
R206	270 Ω , 1/4 Watt Resistor
R301	100 k Ω , 1/2 Watt Resistor
P201	500 Ω Trim-Pot Vertical Mounting
D201, D202	1N4148 Silicon Signal Diode
D203	1N4742 Zener Diode (12 Volt, 1 Watt)
D204 - D207	1N4001 or 1N4005 Silicon Power Diode
Q201	MJE521 NPN Transistor with Thermalloy 6107 Heatsink
Q202	MPS3702, MPS3703, MPS6518 PNP Silicon Transistor
Q203, Q204	MPS3394, MPS3395, MPS6514 NPN Silicon Transistor
Q205	MJE370 PNP Transistor
F301	1/4 amp slo-blo Fuse
NE301	NE-2 Neon Lamp
PC301	Power Cord (3-wire)
S303	SPST Power Switch, part of volume control, P302
BR301	6 Terminal Tie-Strip
T301	Power Transformer, Stancor P6375
T302	Power Transformer, Stancor P6465

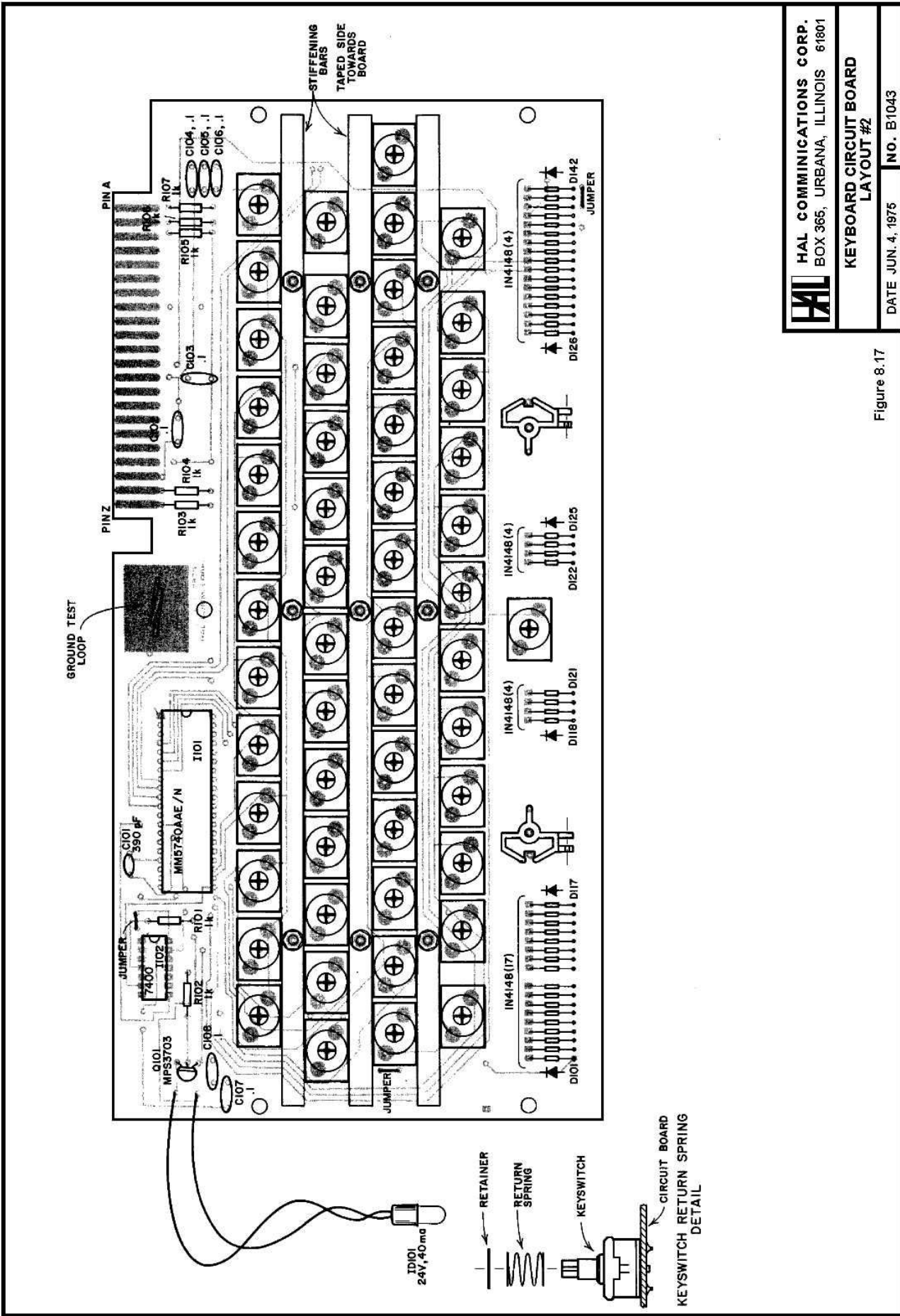
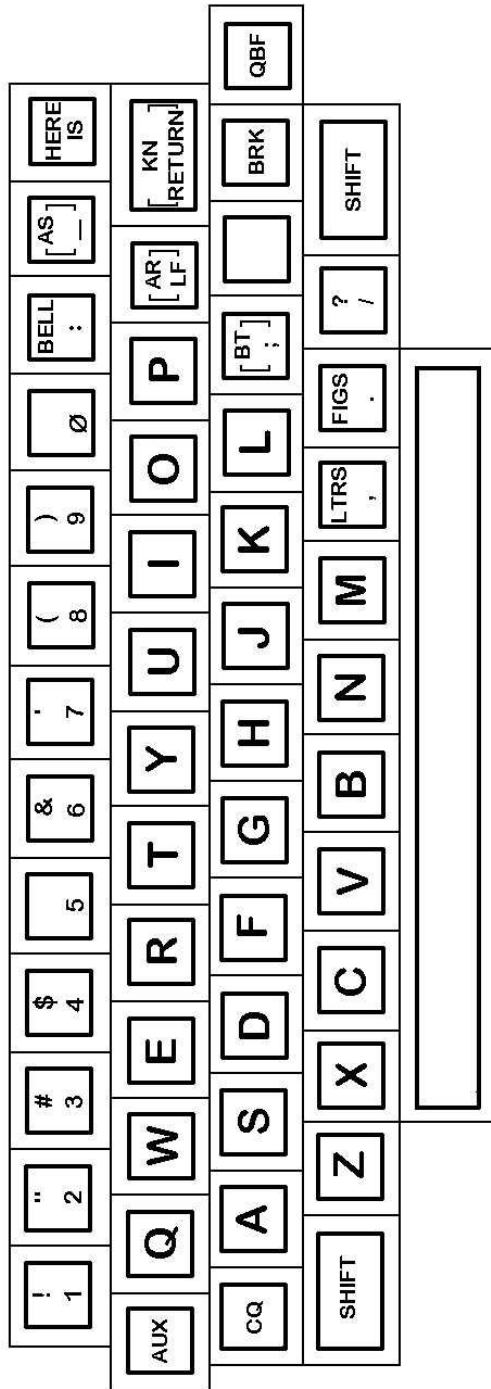

Figure 8.17

HAL HAL COMMUNICATIONS CORP.
 BOX 365, URBANA, ILLINOIS 61801

KEYBOARD CIRCUIT BOARD
 LAYOUT #2

DATE JUN. 4, 1975 NO. B1043



HAL HAL COMMUNICATIONS CORP.
 BOX 365, URBANA, ILLINOIS 61801

KEYTOP POSITION

DATE SEPT. 3, 1974 NO. C1003

Figure 8.18

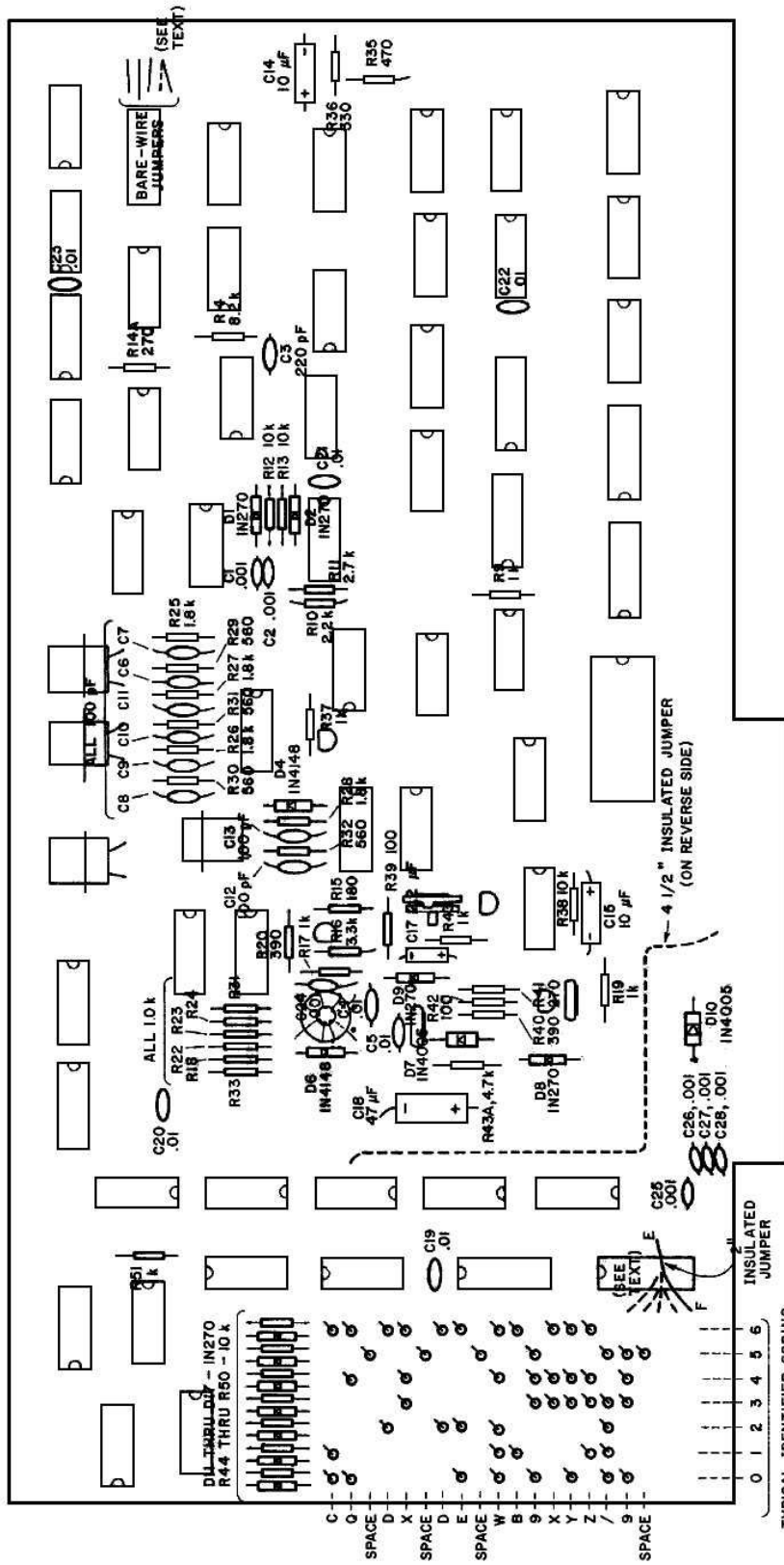

REV. A: JUN. 23, 1975

HAL HAL COMMUNICATIONS CORP.
 BOX 365, URBANA, ILLINOIS 61801

MAIN LOGIC BOARD
 SMALL COMPONENT LAYOUT

DATE OCT. 8, 1974 NO. B1025A

Figure 8.20

TYPICAL IDENTIFIER CODING
 (SEE TEXT)

- 0
- 1
- 2
- 3
- 4
- 5
- 6

**EXTENDED
MEMORY
OPTION
FOR THE
DKB - 2010
KEYBOARD
INSTRUCTION
MANUAL**

HAL DKB-2010 EXTENDED MEMORY OPTION

1. Introduction

The HAL 64/128 Key Buffer option extends the memory capacity of the DKB-2010 Dual Mode Keyboard to 64 or 128 keystrokes, depending on the model chosen. With the buffer installed, the operator is free to type for an extended period at a rate greater than the keyboard transmission speed without losing characters.

Buffer operation is controlled by the shifted CQ, AUX and HERE IS keys. Typing a shifted HERE IS clears the buffer memory. A shifted AUX turns the memory output off, allowing characters to accumulate in the buffer for later transmission. Typing a shifted CQ turns the memory output on; the stored keystrokes are then passed to the keyboard logic circuitry. Complete operating instructions are given in Section 3.

A feature of special importance is that the buffer stores keystrokes rather than individual characters. As a result, the QBF (quick brown fox), identifier, CQ and AUX messages occupy only a single location in the memory. It is possible, for example, to press the QBF key as many as 64 (or 128) times. Each keystroke will be stored, and the keyboard will repeat the entire quick brown fox test message as many times as the key was pressed.

Installation of the buffer requires no wiring changes in the keyboard. The buffer circuit board is fitted with card-edge connectors and simply plugs in between the keyswitch board and the wiring harness connector. Complete installation instructions are given in Section 2.

2. Installation

You will find it very easy to install the buffer in your keyboard by following the steps listed below.

TO PREVENT DANGEROUS ELECTRICAL SHOCK, UNPLUG THE KEYBOARD FROM THE AC OUTLET BEFORE PROCEEDING. 115 Volt (230 V) AC is exposed at several points within the cabinet.

1st Stand the keyboard on its right end. Remove the three screws from the lip of the bottom cover at the rear of the unit. Remove the screw from the center of the front edge of the bottom plate. Slide the bottom plate back to free it from the front lip of the cabinet and lay it flat on the table. The logic board remains attached to the bottom panel.

2nd The large circuit board remaining inside the cabinet is the keyswitch board. It is held into the cabinet with five slotted-head screws – two at the upper end, two at the lower end, and one in the center toward the rear of the cabinet. Remove these five screws, starting with the bottom ones. As you remove the upper screws, hold the circuit board to prevent it from falling from the cabinet.

3rd Swing the upper end of the circuit board away from the cabinet. As you do so, reach behind the board and pull the BUFFER FULL lamp from the plastic lens. Cut the lamp leads off as close as possible to the circuit board. The lamp may be discarded, as it will be replaced by the new lamp connected to the buffer circuit board.

4th Carefully detach the circuit board connector from the contact fingers at the rear edge of the board.

5th Plug the keyswitch board into the card edge connector mounted on the buffer circuit card. Note that the buffer board will be beneath the keyswitch board when the keyboard is in its normal operating position. Then plug the buffer board into the card edge connector previously removed from the keyswitch board. Make certain that the connector has not been reversed – the yellow and red leads should be closest to the power transformer when the keyswitch board is reinstalled.

6th Return the keyswitch board (with the buffer circuit card attached) to its original position in the cabinet. As you do, reach beneath the board and insert the lamp connected to the buffer board into the lens from which the old BUFFER FULL lamp was removed. Then secure the keyswitch board to the cabinet with the five screws removed during disassembly.

7th Reinstall the bottom plate, sliding the front edge beneath the front lip of the cabinet. Fasten it in place with the original screws.

The keyboard and buffer are now ready to operate. Refer to Section 3 for instructions on the use of the buffer.

3. Operating Instructions

Three keys (CQ, AUX and HERE IS) in conjunction with the SHIFT keys control the operation of the buffer.

The shifted HERE IS key clears the buffer of its contents. A shifted AUX stops the flow of characters out of the buffer. The shifted CQ key turns the buffer output on so that the stored characters pass from the keyboard to the logic circuitry and are transmitted.

It is important to observe the proper sequence of operations when using these keys to control the buffer. The SHIFT key must be pressed and held down while one of the control keys is struck. The SHIFT key should not be released until after the control key is released. Otherwise, the character sequence produced by the control key in its normal (unshifted) mode will be entered in the memory unintentionally.

When the keyboard is first switched on, it is not possible to predict the states that the buffer memory stages will assume. It is therefore best to type a shifted HERE IS to clear the buffer and prepare it for incoming keystrokes.

If you wish to use the buffer as an extension of the keyboard's internal three-character memory, type a shifted CQ. The buffer output will be turned on and the characters you type will pass through the buffer to the keyboard logic for transmission. If you type faster than the rate at which the keyboard is transmitting, the additional characters will "stack up" in the buffer and will be passed on to the keyboard logic when it is ready to receive them.

When the buffer is completely filled, the BUFFER FULL lamp will light. In that case, stop typing until the keyboard has had a chance to transmit some of the stored characters. As soon as memory space is available for another keystroke, the BUFFER FULL lamp will go out.

Transmission of the stored keys may be stopped at any time by typing a shifted AUX. The keyboard will transmit the two characters stored in its internal memory, but will not draw any more characters from the buffer. To restart transmission, type a shifted CQ. The contents of the buffer may be erased at any time by typing a shifted HERE IS.

It is possible to use the buffer to store a complete message or character string by typing a shifted AUX prior to typing the first character of the message. The buffer output will be turned off, and any keystrokes will be

recorded in the memory but will not be passed to the logic circuits for transmission. When ready to send the message, type a shifted CQ. Any pauses or gaps which occur when the message is originally typed will be closed up, as the keystrokes are stacked up sequentially in the buffer. If you wish to erase the memory, simply type a shifted HERE IS. The memory contents do not recirculate; once the message has been transmitted, it is no longer present in the memory. If you wish to repeat the message, it must be typed into the buffer again.

Since the buffer, in effect, stores keystrokes rather than individual characters, the QBF (quick brown fox message), HERE IS (identifier message), CQ and AUX keystrokes occupy only a single memory location. It is therefore possible, for example, to store the QBF message and 63 (or 127) other keystrokes in the memory. Note that the repeat feature of the HERE IS, CQ and AUX keys no longer functions when the buffer is installed.

The only keystroke which does not enter the buffer is the "break" (BRK) key function. The break key operates as usual unless the buffer output has been turned off, in which case it is deactivated and has no effect.

4. Theory of Operation

The buffer memory is installed in the DKB-2010 keyboard between the output of the keyencoder and the input of the circuit board. In the standard keyboard, keystrokes are translated into a seven-bit ASCII code by the keyencoder. These codes are fed directly to the ROM, where they are converted to the correct bit pattern for either Morse or RTTY transmission, depending on the mode selected ⁶.

The heart of the buffer is an eight-bit parallel first-in, first-out (FIFO) buffer. Characters from the keyencoder are clocked into the buffer on data Lines A₀ through A₆ each time a keystroke occurs. The character code bits ripple through the buffer stages toward the output end. They are clocked out of the buffer, one eight-bit code at a time, into the keyboard logic circuits when the **ENABLE** signal from the logic circuit indicates that the keyboard is ready to receive them. If the buffer input rate exceeds the output rate, the character codes ripple through the buffer and stack up at the output end, awaiting transfer to the logic circuit.

Each eight-bit buffer consists of two four-bit FIFO buffer IC's operating in parallel (IC's 7 and 8 in the schematic diagram). The buffers are capable of storing up to 64 eight-bit character codes. In the 128-key model, two additional buffers (IC's 10 and 11), in the same parallel configuration, are connected in series with the first two buffers to provide a storage capacity of 128 eight-bit codes.

Additional control logic senses closure of one of the automatic character sequence keys (QBF, HERE IS, CQ and AUX) and enters a special code into the FIFO buffers. When this code reaches the buffer output, it is sensed by one of a series of logic gates which actuates the appropriate character sequencer in the keyboard.

Characters (or keystrokes) from the keyswitch board enter the buffer whenever the READY line from the keyencoder goes high. The stored characters are clocked out of the buffer by a transition of the **ENABLE** line, which occurs whenever the keyboard logic circuits are ready to receive a new character code. When the buffer is full, the R_i (input ready) terminal of the buffer goes low, driving a switching transistor (Q501) into conduction. The BUFFER FULL Lamp, which serves as the transistor's collector load, then lights.

The output of the buffer memory is controlled by IC-5, which forms a flip-flop driven by two control gates. When the AUX key is pressed along with one of the SHIFT keys, the flip-flop is set. An output from the flip-flop controls the READY line, which when high normally indicates that one or more characters have been stored in the buffer awaiting transfer to the keyboard logic. If the flip-flop is set, the READY line is held low, and the keyboard logic is not notified that characters are stored in the buffer. Hence, no clock pulses return via the **ENABLE** line. Incoming characters are stored in the buffer, but are not transmitted.

When the SHIFT and CQ keys are pressed simultaneously, the flip-flop is reset, and the READY line is allowed to go high. The keyboard logic then generates a transition on the **ENABLE** line, clocking the first character out of the buffer. The process repeats until all stored characters have been transmitted.

The buffers may be cleared of all contents by pressing the SHIFT and HERE IS keys simultaneously. A NOR gate senses this combination of key closures and drives the **CLEAR BUFFER** line low, resetting all stages of the shift registers.

⁶ Consult the DKB-2010 instruction manual for a complete discussion of the keyboard logic circuitry.

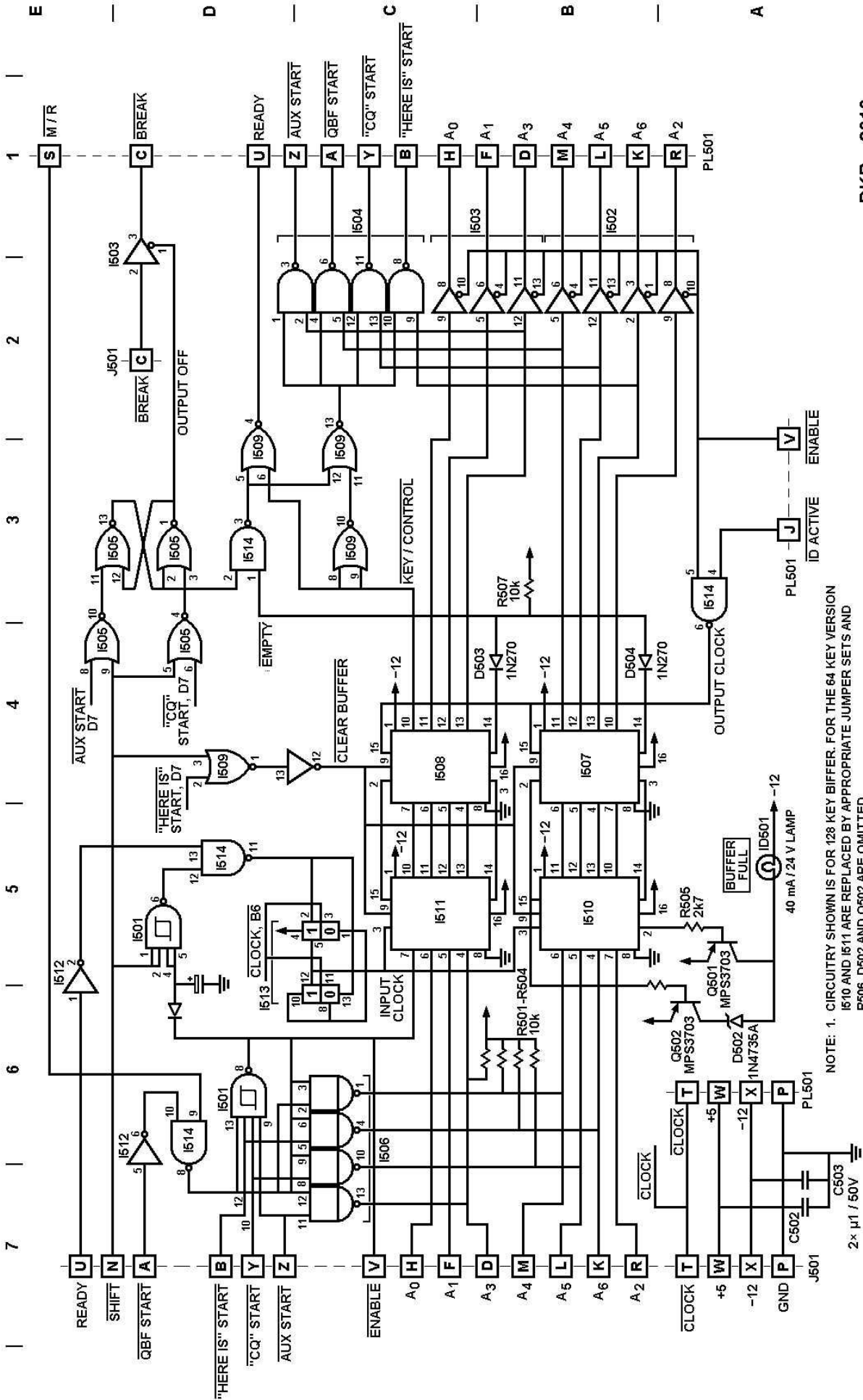

NOTE: 1. CIRCUITRY SHOWN IS FOR 128 KEY BUFFER. FOR THE 64 KEY VERSION I510 AND I511 ARE REPLACED BY APPROPRIATE JUMPER SETS AND R506, D502 AND Q502 ARE OMITTED.

2. ACCEPTABLE SUBSTITUTES ARE:
FOR Q501 AND Q502 = MPS3702 OR MPS6618
3. ALL RESISTORS ARE 1/4 W, ±10 %

DKB - 2010
64 / 128 KEY BUFFER
DEC. 3, 1974
A1030A

INPUT TIMING (1)

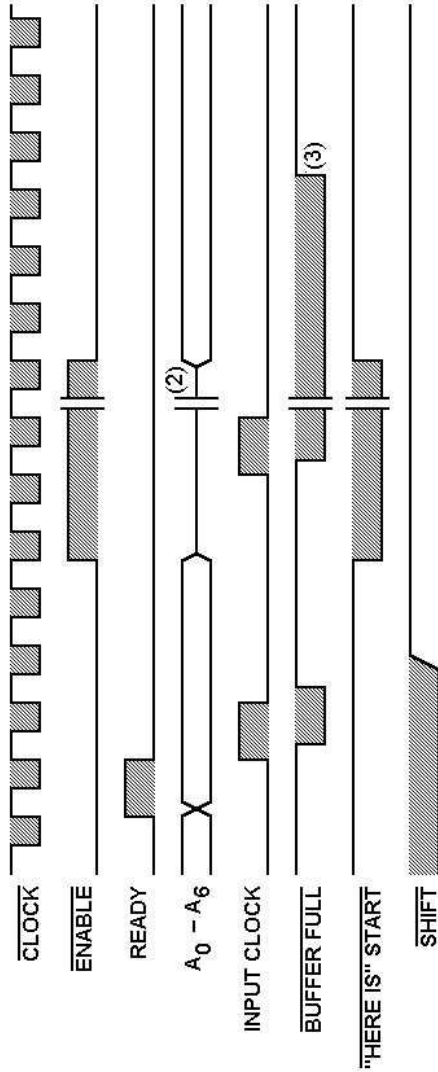

OUTPUT TIMING (4)

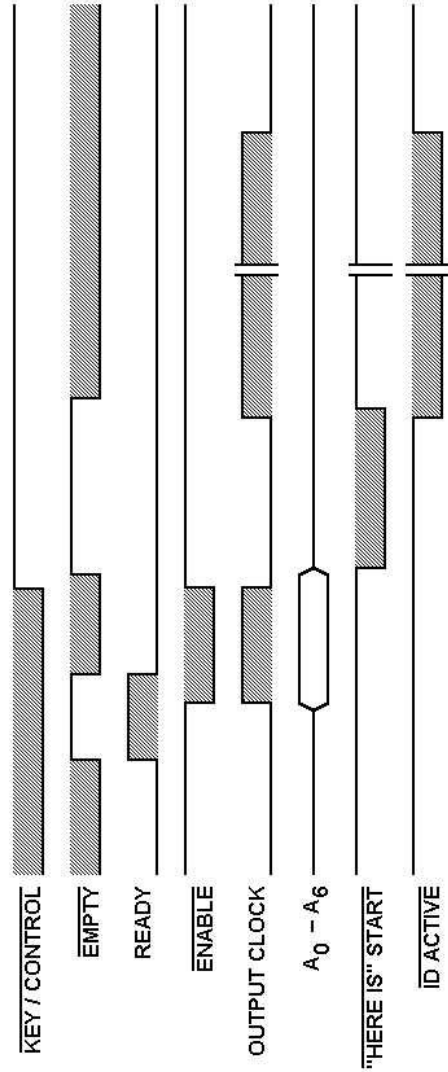

CONTROL TIMING (5)

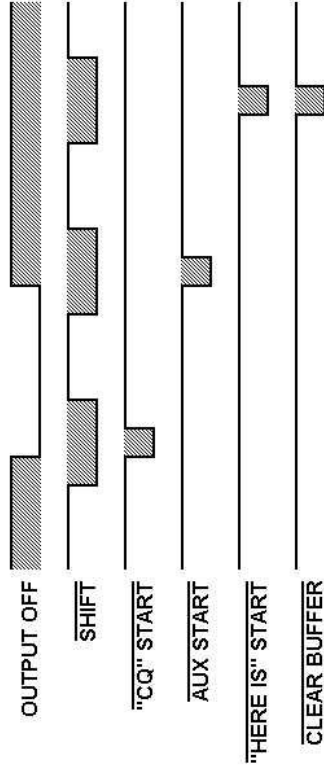

NOTE: 1. INPUT TIMING IS GENERALLY SYNCHRONOUS EXCEPT WHEN BUFFER IS FULL.

2. A_x LINES NOT OTHERWISE DRIVEN GO TO A HIGH-IMPEDANCE STATE WHEN DISABLED (TRI-STATE).
3. THE BUFFER FULL SIGNAL REMAINS LOW (ACTIVE) WHEN NO BUFFER LOCATIONS ARE EMPTY IGNITING THE BUFFER FULL INDICATOR.

4. OUTPUT TIMING IS ASYNCHRONOUS AND VARYING DELAYS ARE ENCOUNTERED BETWEEN CONTROL LINES.

5. A CONTROL CONDITION EXISTS WHEN "CQ", "AUX" OR "HERE IS" IS PRESSED AFTER THE SHIFT KEY AND RELEASED BEFORE THE SHIFT KEY IS RELEASED. THE FUNCTIONS ARE:

- SHIFT - CQ: TURN BUFFER OUTPUT ON
- SHIFT - AUX: TURN BUFFER OUTPUT OFF
- SHIFT - HERE IS: PURGE BUFFER CONTENTS

DKB - 2010

KEY BUFFER TIMING

DEC. 5, 1974

C1004