

ST-6000

FSK

DEMODULATOR

INSTRUCTION MANUAL

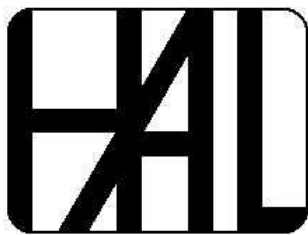

HAL COMMUNICATIONS CORP.

BOX 365

URBANA, ILLINOIS 61801

QUALITY COMMUNICATIONS EQUIPMENT

HAL ST-6000 FSK DEMODULATOR / KEYER

Technical Manual

Copyright © 1976 by HAL Communications Corp., Urbana, Illinois.

February, 1982 Printing
January, 2019, Reprint by DC7XJ

HAL ST-6000 DEMODULATOR

CONTENTS

1.	INTRODUCTION	1-1
2.	SPECIFICATIONS	2-1
3.	INSTALLATION	3-1
3.1	Initial Inspection	3-1
3.2	Use of Factory Supplied Cables	3-1
3.2.1	Audio Input Connection	3-1
3.2.2	Audio Output Connection	3-2
3.2.3	Loop 1 Cable Connection	3-2
3.2.4	Motor Power Connection	3-2
3.2.5	KOS Cable Connection	3-7
3.2.6	Separate Keyboard Connection	3-10
3.2.7	RS-232C Cable Connection	3-10
3.2.8	CW-ID Key Cable Connection	3-10
3.2.9	AC Power Cord Connection	3-10
3.2.10	Ground Connection	3-10
3.3	Alternate Connection to the ST-6000	3-11
3.3.1	Use of External Loop Supplies and Multiple Loop Circuits	3-12
3.3.2	Separate Printer and Keyboard Connection	3-12
3.3.3	Full Duplex Operation of the ST-6000	3-12
3.3.4	External Data Processing Equipment	3-15
3.3.5	External Oscilloscope Connections	3-15
3.3.6	Tone Keyer Control Connections	3-15
4.	OPERATION	4-1
4.1	Front Panel Controls and Indicators	4-1
4.2	Simplified Operating Procedure	4-2
4.3	Reception of Radio Teleprinter Signals	4-2
4.3.1	Receiver for FSK Reception	4-3
4.3.2	Receiver for AFSK Reception	4-4
4.3.3	Tuning a RTTY Signal	4-4
4.4	Use of the ATC Circuit	4-5
4.5	Use of the DTH Circuit	4-5
4.6	Use of the Limiter Switch - FM vs. AM	4-6
4.7	Use of the SENSE Switch	4-6
4.8	Use of the PRINT Switch	4-6
4.9	The KOS Circuit	4-7
4.10	Use of the Autostart Circuitry	4-7
4.11	Antispace Circuitry	4-8
4.12	Tone Keyer Circuit	4-8
4.13	Transmitting Radio Teleprinter Signals	4-9
4.13.1	Transmitting FSK Signals	4-9
4.13.2	Transmitting AFSK Signals	4-11
4.13.3	Adjustment of the ST-6000 Tone Keyer	4-11

5.	ST-6000 CIRCUIT DESCRIPTION	5-1
5.1	ST-6000 Analog Processing Circuits - Input Circuit Board	5-1
5.1.1	Input AGC Circuit	5-1
5.1.2	Input Bandpass Filters	5-1
5.1.3	Limiter Amplifier	5-1
5.1.4	Discriminator Filters	5-2
5.1.5	Discriminator Detectors	5-2
5.1.6	A/S Amplifier and Detectors	5-2
5.1.7	Active Lowpass Filter	5-2
5.1.8	ATC Circuit	5-2
5.1.9	Tone Keyer	5-3
5.2	ST-6000 Control Circuit Board	5-3
5.2.1	Slicer and DTH Circuits	5-3
5.2.2	Antispace Circuit	5-4
5.2.3	Pre-autostart Data Output	5-4
5.2.4	Autostart Circuit	5-4
5.2.5	Standby Circuit	5-4
5.2.6	Post-autostart Data Output	5-5
5.2.7	Loop Keyer Stages	5-5
5.2.8	RS-232/MIL-188 Interfaces	5-6
5.2.9	KOS Circuit	5-6
5.3	Front Panel Indicators	5-6
5.4	Power Supply	5-7
5.5	Oscilloscope	5-7
5.6	Cabinet Wiring	5-8
5.7	User Servicing	5-8
5.8	Troubleshooting Guide	5-9

APPENDIX A:	RF-Induced Problems	6-1
-------------	---------------------	-----

TABLES

Table 4.1	ST-6000 Front Panel Controls	4-1
Table 4.2	ST-6000 Front Panel Indicators	4-2

ILLUSTRATIONS

Figure 3.1	"Standard" Cable Connections to the ST-6000	3-3
Figure 3.2	Loop Connections to the ST-6000	3-8
Figure 3.3	RS-232 I/O Connections to the ST-6000	3-9
Figure 3.4	Preparation of the ST-6000 Connectors	3-11
Figure 3.5	Alternate Loop Connections	3-13
Figure 3.6	Connections for Full-Duplex Operation	3-14
Figure 3.7	Connections to External Data Processing Devices	3-16

Figure 5.1	ST-6000 Block Diagram	5-11
Figure 5.2	ST-6000 Schematic Diagram Conventions	5-12
Figure 5.3	Input AGC Circuit	5-13
Figure 5.4	Input Bandpass Filter	5-14
Figure 5.5	Limiter Amplifier	5-15
Figure 5.6	Discriminator Filters	5-16
Figure 5.7	Discriminator, Meter Amp., Lowpass Filter, ATC	5-17
Figure 5.8	Tone Keyer	5-18
Figure 5.9	Slicer, Antispace, Autostart	5-19
Figure 5.10	Loop Drivers, Loop Sense	5-20
Figure 5.11	RS-232/MIL-188 Interface	5-21
Figure 5.12	KOS Circuit	5-22
Figure 5.13	Power Supply	5-23
Figure 5.14	Oscilloscope	5-24
Figure 5.15	Input Circuit Board Layout	5-25
Figure 5.16	Control Circuit Board Layout	5-26
Figure 5.17	Oscilloscope Circuit Board Layout	5-37
Figure 5.18	Circuit Board Interconnections	5-28

1. INTRODUCTION

The Hal Communications Model ST-6000 is a high performance FSK demodulator and tone keyer designed for use with radio teleprinter systems. The ST-6000 incorporates the features and performance characteristics of previous HAL demodulators as well as offering some features previously not available.

The ST-6000 is an audio tone type of demodulator and keyer. Audio tones from the receiver, representing the "mark" and "space" teleprinter code states, are converted into keying pulses by the demodulator section. Active input and discriminator filters are used in the ST-6000 so that a wide range of input frequencies can be accommodated. Two standard audio tone sets are normally stocked by the factory and special tone sets within the 1200...3000 Hz frequency range are available on special order. The standard tone sets are based on a mark frequency of 1275 Hz ("low-tone" set) or a mark frequency of 2125 Hz ("high-tone" set) for frequency shifts of 170 Hz, 425 Hz, and 850 Hz. The tone keyer section of the ST-6000 generates the same set of tones for transmitting in addition to a narrow-shift tone for Morse code identification.

The demodulator uses a pre-filter AGC system, an active bandpass filter, a high gain, wide bandwidth limiter, and active detector circuits. This combination gives outstanding performance for a wide range of input signal amplitudes even in the face of strong interfering signals. The limiter stage gain can be reduced for non-limiting operation ("AM"). The pre-filter AGC and active detectors also assure improved non-limiting performance when compared to previous demodulators. A three pole active lowpass filter follows the detector stages to reduce the post-detection noise bandwidth.

An Automatic Threshold Correction (ATC) circuit can be switched into the signal chain to provide correction for bias distortion generated by the propagation path. This feature can also be defeated with a front panel switch if desired. A Decision Threshold Hysteresis (DTH) circuit can also be switch selected to provide correction for multi-path propagation distortion of the teleprinter signal.

CMOS digital circuitry is used to provide the automatic printer and motor control as well as the antispacer feature. The ST-6000 autostart circuit senses the presence (or absence) of a valid teleprinter signal. If the input signal is not recognized as a teleprinter signal, the printer is held in the "mark-hold" condition. If more than twenty seconds pass without recognition of a valid signal, the power to the printer motor is removed. The response time of the autostart circuit is switch selectable to allow "FAST" (1.5 sec.) or "SLOW" (3.5 sec.) response. An antispacer circuit is also included in the digital control section that limits the duration of a space signal to 250 ms or less, preventing the "running-open" machine condition on continuous space tones.

As mentioned earlier, the tone keyer section generates the same tone set as is used in the demodulator section to assure true "transceive" conditions. The tone keyer will also generate an additional narrow-shift tone that can be connected to an external keyer circuit for Morse code identification. All tones of the tone keyer are derived from high frequency crystal controlled oscillators. The output signal is a low distortion sine-wave generated in a digital-to-analog converter and then filtered in an active low-pass filter. A wide range of output amplitude (into 500 Ohms) is available from the ST-6000, adjustable with an internal control. Unlike previous demodulators, the tone keyer data input circuit is not internally connected to the demodulator but is available on a rear panel connector. Thus, separate transmit and receive circuits (full-duplex) can be accommodated by the ST-6000. Conversely, with appropriate rear-panel jumpers, the tone keyer can be connected to the demodulator for a common transmit/receive circuit (half-duplex) as was the case for the ST-6 demodulator. However, the shift of the tone keyer is controlled by the front panel SHIFT switches. Also, the SENSE switch (NORM - REV) controls both the tone keyer as well as the demodulator.

The ST-6000 input and output circuits have been designed to allow a maximum of user flexibility. Many signal and control lines have been brought-out to rear panel connections. Both pre- and post-autostart data signals are available on the rear panel as are the inputs and outputs of two separate high-level loop switches. The internal 175 Volt, 50 mA loop supply is also connected to the rear panel. Thus, the demodulator output can be used to directly key the loop or be first passed through additional signal processing (such as the popular UART and digital control devices), and then routed back through the ST-6000 keyer stages, with the option of using or not using the internal loop supply of the ST-6000. In addition, the ST-6000 has both output and input signal connections that are compatible with both the EIA - RS-232C and MIL-STD-188C data signal levels.

The ST-6000 also includes a Keyboard Operated Switch (KOS) circuit that can be used to automatically switch the transmit receive control circuitry of the station. The KOS circuit senses teleprinter keyboard and CW identification signal status. If either the keyboard or the CW-ID key is used, the KOS switching transistor turns "ON" (low impedance to ground). The KOS circuit also places the ST-6000 demodulator circuits in a "standby" status to prevent feedback from the receiver while transmitting. The NPN KOS switching transistor can be used to control a DC relay that is supplied from a positive voltage source or a push-to-talk (PTT) control line in a transmitter (providing the PTT line is derived from a positive DC source.) Since the KOS sensing line is connected to the rear panel, it can also be triggered by external devices.

The audio input to the demodulator and the audio output from the tone keyer are both 500 Ohms balanced (or unbalanced if jumpered) with respect to ground and use audio transformers to maintain DC isolation. The oscilloscope signals for a crossed-ellipse oscilloscope display are connected to a rear panel connection. The ST-6000 is furnished with a front panel tuning oscilloscope.

Internal, electronically regulated ± 12 Volt power supplies provide operating voltages for the demodulator, control and tone keyer sections of the ST-6000. A 175 Volt, 50 mA loop power supply is also included as a part of that option. The main power transformer of the ST-6000 can be connected for operation with either 105 to 125 VAC or 210 to 250 VAC, 50 or 60 Hz power sources. Both the power line and the loop power supply are fused with fuses accessible from the rear panel of the unit. The ST-6000 requires approximately 20 watts of AC power and is housed in an attractive brown and tan cabinet that matches the DS-3100 ASR and other HAL Communications Video Display Terminals. The cabinet can be supplied for either table or relay-rack mounting.

A complete set of cables and connectors are furnished with the ST-6000 to simplify the initial installation of the ST-6000. If you are anxious to try your ST-6000, it is suggested that you skip to sections 3.1 and 3.2 of the installation chapter and then read sections 4.1 and 4.2 of the operation chapter before turning the equipment on. The balance of this manual should then be studied before attempting any "custom" connections.

2. SPECIFICATIONS

Demodulator Section:

Input data:	Serial Data
Data rate:	Up to 110 baud
Input Impedance:	500 Ohms, balanced and isolated from ground
Input frequencies:	
"Low-tone" set:	Mark = 1275 Hz Space = 1445 Hz (170 Hz shift) 1700 Hz (425 Hz shift) 2125 Hz (850 Hz shift)
"High-tone" set:	Mark = 2125 Hz 2295 Hz (170 Hz shift) 2550 Hz (425 Hz shift) 2975 Hz (850 Hz shift)
"Special" tone sets	Audio frequencies between 1200 and 3000 Hz; mark tone must be common to all shifts; 850 Hz- maximum recommended shift.
Input signal amplitude:	Full limiting (FM mode) for signal levels between -50 dBm and +20 dBm (approximately 1 mV to 10 V rms). When "AM" mode (non-limiting) is used, input signal should be in the range -40 to +20 dBm (approximately 10 mV to 10 V).
Input Filter -3 dB Bandwidth: (all tone-sets)	850 Hz shift - 1250 Hz 425 Hz shift - 775 Hz 170 Hz shift - 275 Hz
Discriminator filters -3 dB Bandwidth (all tone sets):	850 Hz shift - 180 Hz 425 Hz shift - 125 Hz 170 Hz shift - 70 Hz
Low-pass filter bandwidth:	82 Hz (minimum for 110 baud)

Tone Keyer Section:

Input data:	Serial Data
Data rate:	Up to 110 baud
Input signals:	Can be externally connected for: 1. sensing of current loop 2. sensing of EIA-RS-232C signals 3. sensing of MIL-STD-188C signals 4. sensing of "dry" keyboard contacts 5. CW-ID key 6. CMOS-compatible signal mark = 0 V space = +12 V
Output tones:	Standard - same tones as demodulator input Special - any tones in the 1200 to 3000 Hz frequency range, mark tone common to all shifts. In addition, a CW-ID tone is generated 100 Hz <u>below</u> the mark tone; CW-ID = 1175 Hz for "low-tones", 2025 Hz for "high-tones".
Output muting:	Tone keyer output can be turned off and on via rear panel connection (TONE ENABLE)
Tone accuracy:	±0.1 %

Tone amplitude: Adjustable from -40 dBm to 0 dBm (approximately 10 mV to 1.0 V)
 Amplitude variation: Less than ± 0.5 dB at 0 dBm output
 Output impedance: 500 Ohms, balanced to ground
 Distortion: All harmonics below the 9th are attenuated greater than 40 dB (Less than 1.0 % total harmonic distortion).

Control Section:

Autostart response time: Switch selectable: Slow = 3.5 sec.
 Fast = 1.5 sec.
 Motor control delay time: 20 seconds nominal
 Antispace time: Space condition greater than 250 ms
 KOS delay: Turn-on: Space condition longer than 5 ms or upon key down of CW-ID key
 Turn-off: Space condition longer than 500 ms or Mark condition longer than 1 to 10 sec. (adjustable) or 1 sec. after CW-ID key opening
 KOS NPN switch transistor: Off: +25 VDC maximum
 On: 500 mA maximum

Tuning Indicator: X - Y, 1" diameter oscilloscope display; rear panel connections for additional oscilloscope.

Automatic Threshold Control: (ATC) Performs DC level restoration to provide correction for bias distortion in received signals; can be disabled with front panel switch.

Decision Threshold Hysteresis: Provides switching hysteresis to provide correction of distortion caused by multipath propagation effects; can be disabled with front panel switch.

Demodulator Outputs:
 Current Loop: Two independent 250 Volt, 100 mA NPN switching transistors that may be connected to the internal 175 Volt, 50 mA loop power supply or to external supplies.

EIS - RS-232C compatible: Mark = -12 VDC
 Space = +12 VDC

MIL-STD-188C Compatible: Mark = +6 VDC
 Space = -6 VDC

CMOS compatible:
 (4000 series, +12 supply): Pre-autostart data: Mark = 0 to +3.6 VDC
 Space = +8.4 to +12.0 VDC
 Post-autostart data: Mark = 0 to +3,6 VDC
 Space = +8.4 to +12.0 VDC

Miscellaneous Data:

Fuse protection:	Main AC Power - 0.5 A, slow-blow Loop Power Supply - 0.1 A Accessible from rear Panel
Power requirements:	105 to 125 or 210 to 250 VAC, 50 or 60 Hz, 20 Watts (excluding printer motor)
Cabinet size:	Width 17" (43.2 cm) - table 19" (48.3) - rack Height 3.5" (8.9 cm) Depth 9" (22.8 cm)
Cabinet finish:	Light tan front and rear panels Textured brown top, bottom, and side panels Baked vinyl paint to match HAL video terminals
Weight:	12.0 lbs (5.45 kg) net 15.0 lbs (6.82 kg) shipping
Front Panel Controls:	
SHIFT (HZ) (3 switches):	Select 170 Hz, 425 Hz or 850 Hz shift; controls <u>both</u> the demodulator and tone keyer sections.
LIMITER ON-OFF:	Allows the demodulator section to be used in either limiting (FM) or non-limiting (AM) modes.
SENSE NORM-REV:	NORM = mark is lower tone REV = mark is higher tone Affects <u>both</u> the demodulator and tone keyer sections.
ATC ON-OFF:	Turns Automatic Threshold Control on or off.
DTH ON-OFF:	Turns Decision Threshold Hysteresis circuit on or off.
PRINT LINE-LOCAL:	LOCAL = demodulator signals are inhibited to permit "local" operation.
KOS ON-OFF:	Turns the keyboard operated switch sensing circuit on or off.
AUTOSTART FAST-SLOW:	FAST = 1.5 sec. response time. SLOW = 3.5 sec. response time.
AUTOSTART ON-OFF:	Turns the autostart circuit on or off.
POWER ON-OFF:	Turns AC power to the demodulator on or off.
Oscilloscope:	
INT:	Controls intensity of oscilloscope trace
FOC:	Controls focus of oscilloscope trace
VER:	Vertical trace position control
HOR:	Horizontal trace position control
Front Panel Indicators:	
Oscilloscope	Indicates correct tuning with the standard crossed ellipse patterns.
LOOP:	LED lamp that is on when Loop 1 is in mark condition, regardless of autostart or LINE-LOCAL condition.
SPACE:	LED lamp that is on whenever post-autostart data is in space condition.
MARK:	LED lamp that is on whenever pre-autostart data is in mark condition.
KOS:	LED lamp that is on whenever the KOS circuit is in transmit condition.
AUTO:	LED lamp that is on whenever the autostart circuit will pass data.
POWER:	AC power-on indicator.

Rear Panel Connections:

AC power input (unlabeled):	Universal U.S./European standard connector for 120/240 VAC non-captive AC power cords.
MOTOR:	Three-prong AC socket to supply printer motor power controlled by the autostart circuitry. The voltage available is the <u>same</u> as the power line voltage to the ST-6000.
Ground (ground symbol)	Cabinet ground connection for safety and RF ground connection.
AC POWER .5 A - SB:	AC power fuse for ST-6000 only (not for the MOTOR socket).
LOOP .1 A:	Loop power supply fuse.
LOOP 1 & 2:	Main and auxiliary loop switch connections internal loop power supply connection, CW-ID hand key connection.
LOOP 3:	Additional series loop connection that can be used with loop 1 or loop 2.
KOS:	KOS control line Keyboard connection
RS-232 / MIL-188:	Data input/output connections for EIA-RS-232C and MIL-STD-188C connections, CW-ID hand key connection.
SCOPE:	Connection for external X-Y oscilloscope display.
AUXILIARY CONTROL:	15 pin connector to provide access to many control and signal lines of the ST-6000. A circuit-board jumper plug is furnished to make "normal" jumpers.
AUDIO OUTPUT:	Balanced 500 ohm tone keyer output.
AUDIO INPUT:	Balanced 500 ohm demodulator tone input.

NOTE: All of the above specifications are nominal, design-center values and may vary in production units by as much as $\pm 10\%$. HAL Communications Corp. reserves the right to alter any specifications without prior notification.

3. INSTALLATION

3.1 Initial Inspection

Upon receipt of the ST-6000, unpack and inspect it carefully for shipping damage. If evidence of shipping damage is found, contact the carrier immediately. Before discarding the packing material, check that all parts and accessories are accounted for. If any are missing, please notify the factory or distributor in writing so that replacements can be supplied. The following parts and accessories are furnished with the ST-6000:

Accessory parts:

- 1 - Non-captive AC power cord
- 1 - 15 pin Auxiliary jumper plug (shipped in place on Auxiliary connector)
- 1 - 3 pin Loop 3 jumper plug (shipped in place on Loop 3 connector)
- 1 - Audio Input cable (phone to three pin male connector)
- 1 - Audio Output cable (phone to three pin female connector)
- 1 - Loop 1 cable (2-conductor cable to female 6 pin connector)
- 1 - KOS cable (2-conductor cable to male 3 pin connector)
- 1 - CW-ID and RS-232C Output cable (2, 2-conductor cables to 6 pin male connector, mates with RS-232 / MIL-188 connector)
- 12 ft - 2-conductor shielded cable
 - 2 - 6 pin female connector shells (03-09-2061)
 - 2 - 6 pin male connector shells (03-09-1061)
 - 4 - 3 pin female connector shells (03-09-2031)
 - 6 - 3 pin male connector shells (03-09-1031)
 - 2 - 15 pin female connector shells (03-09-2152)
 - 60 - male cable pins (02-09-2143)
 - 24 - female cable pins (02-09-1143)
 - 2 - 0.5 ampere, slow-blow fuses
 - 2 - 0.1 ampere fuses

CAUTION: A SERIOUS SHOCK HAZARD MAY EXIST WHEN CONNECTING THE ST-6000 TO OTHER EQUIPMENT. BEFORE MAKING ANY CONNECTIONS, BE SURE TO DISCONNECT THE ST-6000 AND OTHER EQUIPMENT FROM THE AC POWER LINE.

3.2 Use of Factory Supplied Cables

A total of five factory prepared cable-plug combinations and two jumper-plugs are supplied with the ST-6000. These cables and plugs can be used to make most standard input and output connections to the ST-6000, particularly those connections in which an ST-6 or similar demodulator is being replaced by the ST-6000. The use of these standard cables and jumpers is discussed in the following sections. Figure 3.1 shows in pictorial form some of the possible connections to these standard cables.

3.2.1 Audio Input Connection

The audio input cable supplied mates with the rear panel audio input connector and has a phono pin plug on the other end for connection to the station receiver. If the receiver output does not have a phono connector, the plug may be cut off of the cable and replaced with the proper type, or a new cable can be prepared using the procedures described in section 3.3.

3.2.2 Audio Output Connection

A factory-prepared cable is likewise provided for connection of the tone keyer output of the ST-6000 to the station transmitter. This cable also has a phono plug connector which may be used or removed as the particular connections dictate. The output level of the tone keyer is adjustable with an internal control over the range of -40 dBm to 0 dBm. See section 4.13 of the operations section for proper adjustment procedures. If a different audio output cable is required, see section 3.3 for proper preparation procedures.

3.2.3 Loop 1 Cable Connection

There are three ways in which current-loop operated devices may be connected to the ST-6000; "Loop 1", using the "Main" transistor keyer, "Loop 2", using the "Auxiliary" transistor keyer, and "Loop 3", a jumper connection in series with the internal 60 mA loop power supply. The factory supplied cables and jumper plugs are arranged so that the internal loop power supply, "Loop 3" jumper, and "Loop 1" main keying transistor are series connected. "Loop 2" is not connected with the standard cables and plugs. Alternate applications of the loop connections are discussed in section 3.3.1. Current-loop sensing devices such as teleprinters and electronic displays and keyboards can be connected to the nominal 60 mA loop circuit using the cable labeled "Loop I". If the device is polarity sensitive (such as the DKB-2010 keyboard and the DS-3000 KSR Terminal), the white wire is the "positive" connection and the black the "negative". The shield of the cable is NOT connected in the loop circuit but is connected to the ST-6000 cabinet. The shield wire should therefore be connected to the cabinet of the teleprinter or electronic device as a safety ground. A typical connection to a 60 mA teleprinter is shown in Figure 3.1. Notice that the selector magnets and keyboard contacts of the machine are series connected. Also, since the standard cables and jumpers connect the ST-6000 internal loop supply, an external loop power supply should NOT be included in the loop circuit. Additional TTY equipment can be connected in the loop by breaking the jumper on the LOOP 3 plug and series connecting the devices. On the LOOP 3 plug, pin 1 is positive, Pin 3 is negative, and pin 2 cabinet ground. Other loop connections possible with the standard cables are shown in Figure 3.2. Alternate loop connections are discussed in section 3.3.1.

3.2.4 Motor Power Connection

The power for the teleprinter motor can be supplied by the MOTOR connector of the ST-6000. The power to this connector is controlled by the autostart relay of the ST-6000. The TOTAL current supplied by this receptacle should not exceed 10.0 Amperes. The following precautions should be observed when using the MOTOR receptacle:

1. The power to the MOTOR receptacle is NOT fused in the ST-6000. The user should be sure that any device attached to this connector has its own fuse protection.
2. The AC voltage furnished on the MOTOR receptacle is the SAME as the AC power line voltage supplied to the ST-6000; if the ST-6000 is operated from a nominal 240 VAC power line, the MOTOR receptacle also furnishes 240 VAC.

DS3100 ASR

ST6000

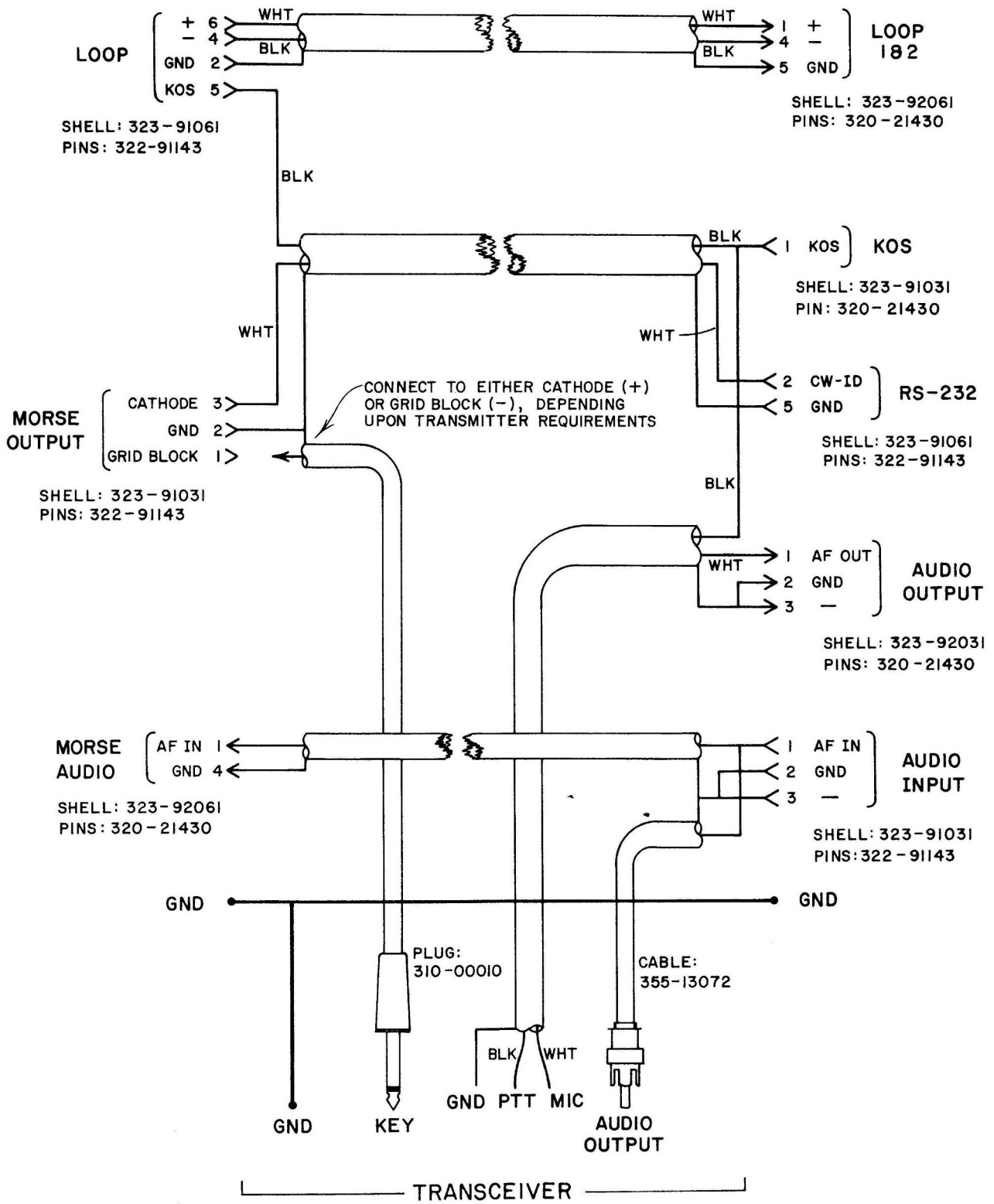

Note: The data connection between the DS-3100 and the ST-6000 is via a loop connection, not an RS-232 connection. The "RS-232" connector on the ST-6000 is only used to connect the CW-ID line to the demodulator.

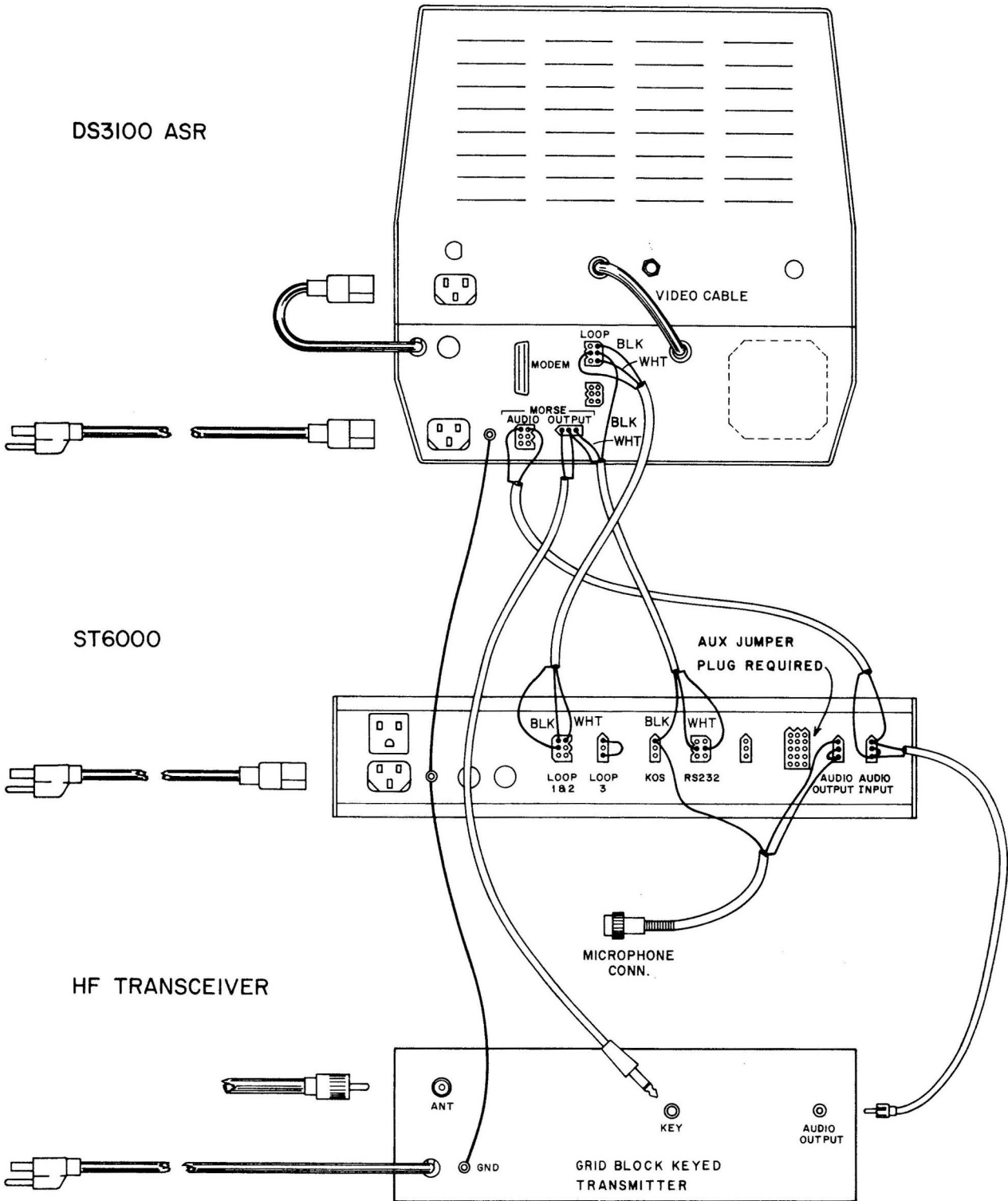

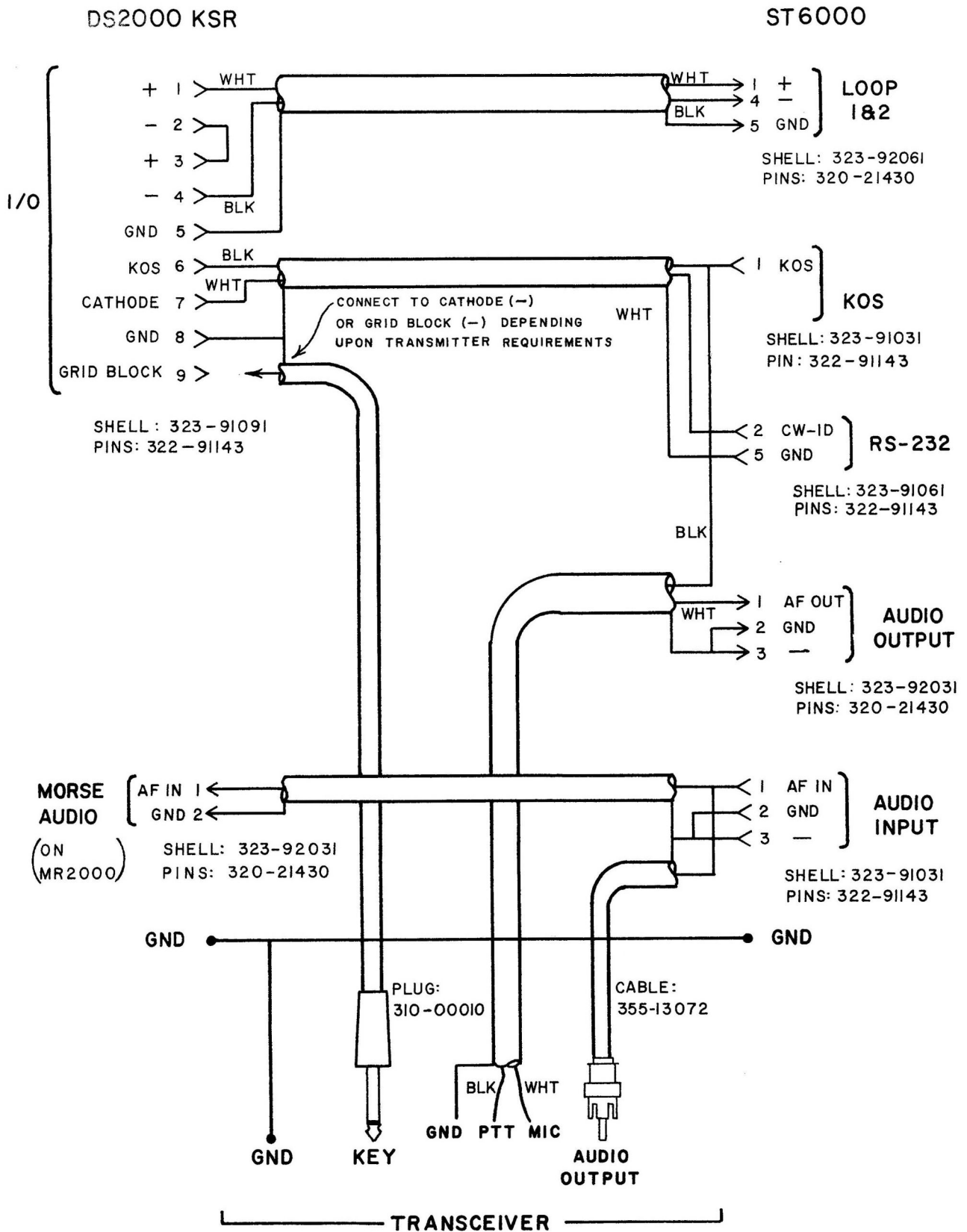

Figure 3.7 DS-2000 and ST-6000 System Connection Schematic

3.2.5 KOS Cable Connection

The wires from the KOS cable can be connected to the transmitter push-to-talk (PTT) control line for automatic transmit-receive control of the station. The jumpers on the factory-supplied AUXILIARY jumper plug allow operation of the KOS circuit when the keyboard and printer sections of the teleprinter are series connected to LOOP 1 (or LOOP 3). A complete discussion of the operation of the KOS-circuit is found in section 4.9. Alternate KOS circuit connections are also discussed in a later section. The following precautions should be observed when using the KOS cable:

1. The KOS switching transistor in the ST-6000 is an NPN transistor. The transmitter push-to-talk (PTT) line should have a positive voltage with respect to ground in receive condition.
2. Shunting the PTT line to ground should place the station in transmit mode.
3. The voltage of the PTT circuit should not exceed +25 Volts (receive).
4. The current drawn through the KOS transistor in transmit mode should not exceed 500 mA.
5. If negative or AC voltages are to be controlled by the KOS circuit, a DC relay should be used to isolate the KOS and PTT circuits.
6. The KOS connection is to the white wire (+) and the shield wire (ground).

NOTES ON THE USE OF ST-6000 RS-232 I/O CONNECTIONS

1. Modify the standard Auxiliary Jumper Plug circuit board by adding a wire jumper between Pin 13 (Transmit Loop Drive) and Pin 14 (Local Data Out).
2. Using the pins and connector shells provided, make a new jumper plug for the Loop 1 & 2 connector (J8). Connect a wire jumper between pin 1 (Loop High) and pin 4 (Loop Low); connect a second wire jumper between pin 3 (Keyboard Data In) and pin 5 (Ground). Use a six pin female shell and male pins.
3. Plug-in the standard Loop 3 jumper plug furnished.
4. Use the standard RS-232 I/O cable to connect to the terminal or machine.

The ST-6000 and terminal will now operate in the half-duplex mode using RS-232 I/O interface connections. The RS-232 data from the terminal will both drive the ST-6000 Loop 1 circuit and operate the KOS circuitry. A teleprinter connected into the Loop 1 circuit will print data generated on the RS-232 terminal or data demodulated by the ST-6000. A keyboard can be connected in the Loop 1 circuit, if desired.

RS-232 Full-duplex operation with the ST-6000:

The following steps should help clarify use of the RS-232 Input/Output connections for full-duplex operation with the ST-6000:

1. Refer to Figure 3.6 and modify the Auxiliary Jumper Plug circuit board as shown, removing the circuit board jumpers between pins 1 and 5 and between pins 11 and 15; add a wire jumper between pins 14 and 15.
2. Using the pins and connector shells provided, make a new jumper plug for the Loop 1 & 2 connector (J8). Connect a wire jumper between pins 1 and 4 and a second wire jumper between pins 3 and 5 of the plug. Use a six pin male shell and female pins.
3. Plug-in the standard Loop 3 jumper plug furnished.
4. Use the standard RS-232 I/O cable (as modified above) to connect to the terminal or machine.
5. Use the front panel switch to turn the KOS circuit OFF.

A printer may again be inserted in the Loop 1 circuit but will now print ONLY received data and not data originating from the RS-232 terminal.

NOTE: JUMPER DS 2000 I/O PINS 2 AND 3 TOGETHER

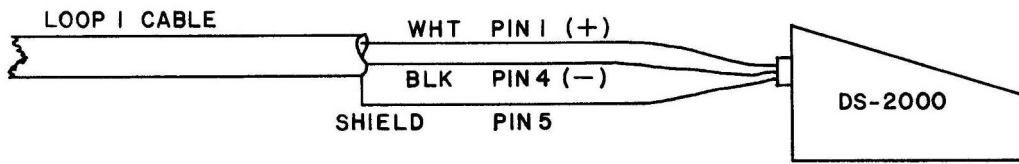

LOOP CONNECTION OF DS - 2000 KSR

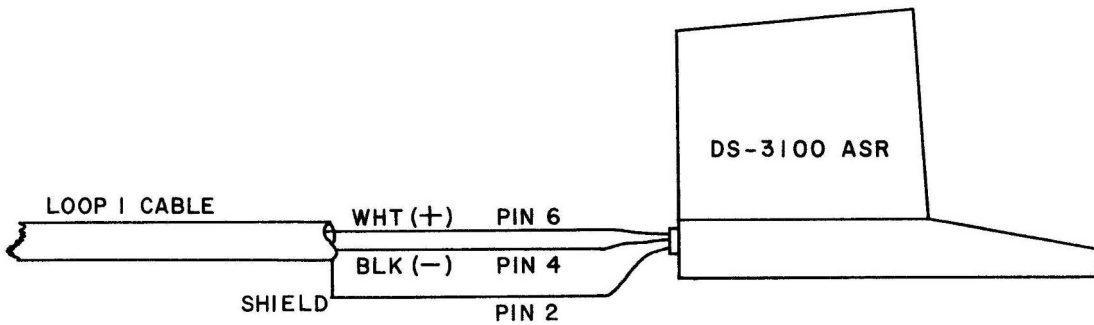

LOOP CONNECTION OF DS-3100 ASR

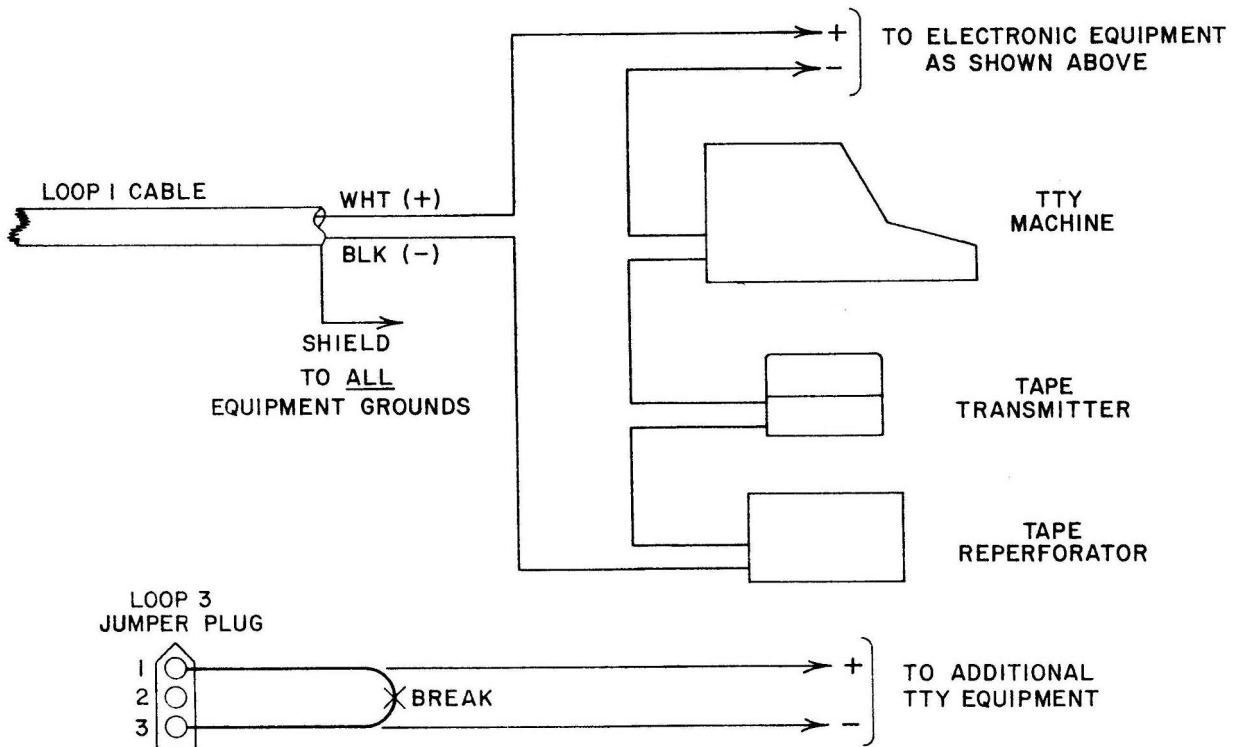

LOOP CONNECTION OF ELECTRONIC AND MECHANICAL EQUIPMENT

Figure 3.2 Loop Connections to the ST-6000

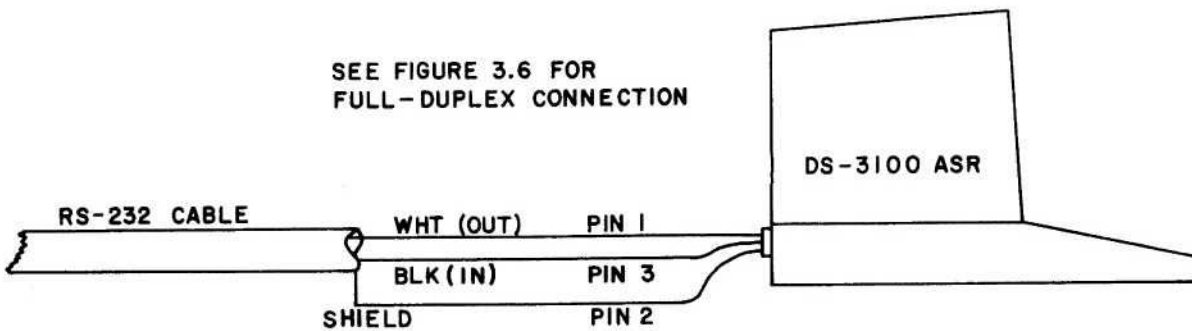

USE OF RS-232 I/O TO CONNECT TO THE DS-3100 ASR

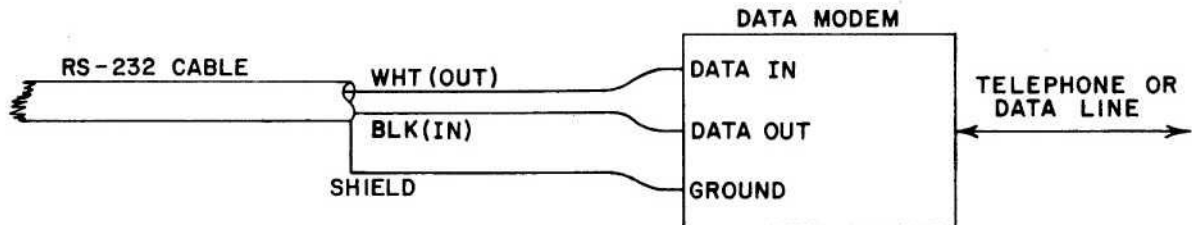

CONNECTION OF THE ST-6000 TO DATA MODEM

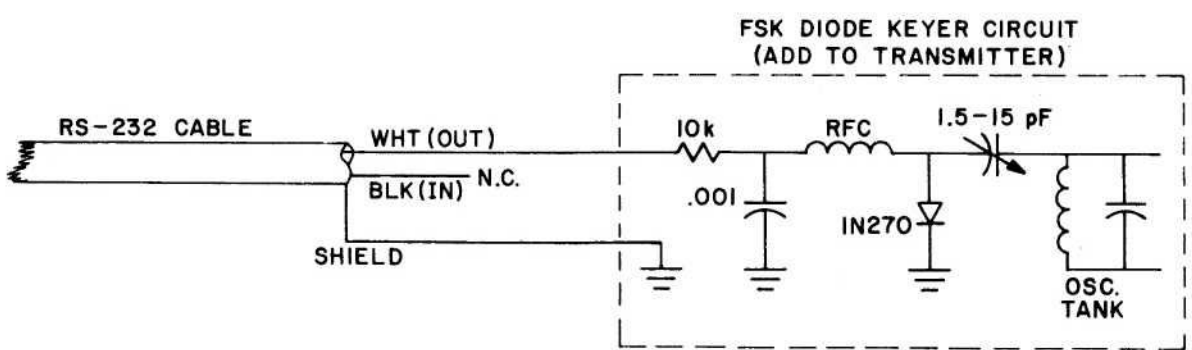

USE OF RS-232 OUTPUT TO DRIVE DIODE FSK CIRCUIT

Figure 3.3 RS-232 I/O Connections to the ST-6000

3.2.6 Separate Keyboard Connection

The black wire and shield from the KOS cable can be connected to a separate keyboard circuit that switches to ground (such as the DKB-2010). The switch element should either be an NPN transistor (switching to ground) or "dry" contacts (keyboard contacts isolated from any voltage or current sources). Since the standard connection of the teleprinter and DKB-2010 is in the series current loop (LOOP 1), this connection will not generally be used. However, when the separate keyboard connection is used, operation of the keyboard will also operate the KOS circuit.

3.2.7 RS-232C Cable Connection

Two factory prepared cables are attached to a 6 pin connector that mates with the RS-232/MIL-188 rear panel connector. One of these cables is labeled "RS-232". This cable can be used to drive the "VOLTAGE" or "EIA" or "RS-232" inputs of the RVD-1002, RVD-1005 or DS-3000 KSR solid-state equipment. The white wire of the RS-232 cable is the RS-232 data output and the black wire is for input of RS-232 data to the tone keyer as connected by the AUXILIARY jumper plug. The white wire and shield should be connected to the VOLTAGE or EIA/RS-232 input of the units. In addition, the black wire may be connected to the RS-232 data output connection of the DS-3000 KSR. Typical connections to the RS-232 cable are shown in Figure 3.3. Refer to page 3-? before using RS-232 I/O connections.

3.2.8 CW-ID Key Cable Connection

A second cable from the RS-232/MIL-188 connector is labeled "CW-ID". This cable should be connected to the station Morse code hand key or electronic keyer to provide narrow-shift CW identification of the transmitted signal. When an electronic keyer is used, the output circuit for cathode keying should be used, instead of the grid-block keying circuit. In no case should the keyer reflect any negative voltage or positive voltages greater than +12 to the ST-6000.

3.2.9 AC Power Cord Connection

The ST-6000 can be internally connected to operate from power sources in two voltage ranges: 105 to 125 VAC or 210 to 250 VAC, 50 or 60 Hz. The rear panel power cord connector is of the "universal" USA/European type and mating power cords can be obtained for most common wall connectors. The ST-6000 is normally factory wired for operation from 105 to 125 VAC, 50 to 60 Hz power lines. Upon request at the time of the order, the ST-6000 can also be supplied for 210 to 250 VAC, 50 to 60 Hz operation. When the 210 to 250 VAC connection is supplied, it is indicated by a small tag on the rear panel of the ST-6000. If this tag is NOT on the rear panel, do NOT connect the ST-6000 to a 240 Volt line without first checking the internal wiring of the power transformer. Particular attention should be given to the precautionary notes of section 3.2.4 when connecting to the MOTOR receptacle.

The proper power transformer primary connections are:

105 to 125 VAC, 50/60 Hz: jumper terminal 1 to 3 & 2 to 4, connect power line to terminals 1 & 4.
210 to 250 VAC, 50/60 Hz: jumper terminal 3 to 2, connect power line to terminals 1 and 4.

These connections are shown in Figure 5.13.

3.2.10 Ground Connection

The ST-6000 cabinet should ALWAYS be connected to an adequate ground system. A three-prong grounding type AC power plug is furnished for connection to a grounded-outlet power system (105–125 VAC connection). If the wiring of the building is correct, use of the grounding AC plug should provide an adequate SAFETY ground return for the instrument. However, it is a good

idea to first check the outlet wiring with a multimeter before plugging-in the unit. If a three-prong AC outlet is not available, use a three to two-prong adapter at the wall socket and connect a separate ground lead between the adapter ground lead or ST-6000 cabinet and a good ground. When using 210 to 250 VAC power mains, be sure to connect the cabinet to a good safety ground. OPERATION OF THIS EQUIPMENT WITHOUT AN ADEQUATE SAFETY GROUND INVALIDATES THE WARRANTY.

When the ST-6000 is used in a radio communications system that includes a high-powered transmitter, a short length of low-inductance wire (1/4" wide shield braid is recommended) should be used to interconnect all equipment cabinets, including the ST-6000 and all teleprinters, etc. Lack of a good RF ground connection may cause false triggering of the logic in the control sections or other improper operations. Open-wire antenna feedline systems with high standing-wave-ratios can be particularly troublesome to solid state equipment. In such cases, changing the antenna, matching system, and/or feedline to a matched coaxial line system will usually clear-up RF interference. When good RF grounds and low SWR feed-lines are used, the ST-6000 will work with even very high powered transmitter systems.

3.3. Alternate Connections to the ST-6000

In order to achieve maximum interfacing flexibility, a great number of the ST-6000 signal and control lines are brought out to rear panel connections. The most common connections are represented by the factory prepared cables and jumpers. When these connections are used, the ST-6000 will function in a manner similar to that of the previous model ST-5 demodulator (with the addition of the extra features of the ST-6000). A number of additional I/O connections, such as use of an external loop supply, full duplex operation, and connection to a UART data conditioning device can be accommodated by making additional cables and/or changing the jumpers on the AUXILIARY connector. Spare connector pins and shells are provided for these connections. Follow the instructions in Figure 3.4 when preparing the connectors. Be sure that the wire and pin are inserted in the correct connector shell location. If it is necessary to remove the pin from the shell, a special tool, Molex® part number HT-2038, can generally be obtained at an electronics supply store.

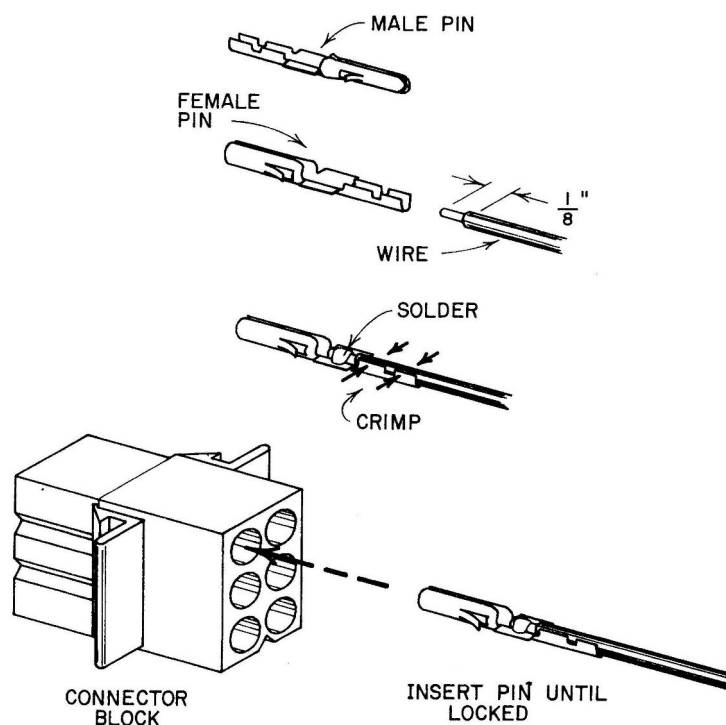

Figure 3.4 Preparation of the ST-6000 Connections

The general block diagram of the ST-6000 and a listing of the rear panel pin connections is shown in Figure 5.1. The connections made by the AUXILIARY jumper plug furnished are shown by the dotted lines. This figure, as well as the discussions of section 5, Theory of Operation, should be carefully studied before alternate connections to the ST-6000 are attempted. The following sub-sections discuss some of the possible alternate connections that may be desirable.

3.3.1 Use of External Loop Supplies and Multiple Loop Circuits

As can be seen from Figure 5.1, the ST-6000 contains two loop switching transistors, Q1 (Main keyer stage) and Q2 (Auxiliary keyer stage). Both of these transistors switch a positive voltage to ground on Mark condition and are both driven from a common data source. The internal, 175 Volt, 60 mA (nominal) loop power supply is connected through the LOOP 3 jumper plug to a pin on the LOOP 1 & 2 plug. The standard connection to the loop is between pins 1 and 4 of this connector, thus using the internal loop supply, LOOP 3 jumper, and Q1, the main keyer stage. However, an external loop supply could be used simply by connecting the loop circuit between pins 4 (the collector and 5 (ground)) of the LOOP 1 & 2 connector. When using this connection, be sure that the positive loop voltage is applied to pin 4, the collector of Q1. Similarly, a SEPARATE loop supply and equipment could be connected to use the auxiliary keyer stage, Q2, by connecting between pins 2 (positive) and 5. When there are a large number of mechanical machines to be drive, it is sometimes desirable to split them into multiple loops to keep the total loop inductance (and therefore distortion) to a minimum. These alternate loop connections are diagramed in Figure 3.5. The keyer transistors themselves, particularly the Auxiliary Keyer (Loop 2), could also be used to switch any data circuit requiring a switch-to-ground operation on mark within the ratings of the transistors (+200 Volts, 100 mA maximum). The Main Keyer (Loop 1) has the loop sense emitter resistor and therefore may not "pull-down" sufficiently when a high current load is switched,

3.3.2. Separate Printer and Keyboard Connections

As mentioned previously in section 3.2.6, the keyboard contacts or keying circuit can be separated from the printer circuit if desired. To do this, connect the printer (or display) to the loop or RS-232 circuit as the conditions require and the keyboard circuit to the keyboard connections available on the AUXILIARY, or KOS, or LOOP 1 & 2 connector. The standard cables include a keyboard connection through the KOS connector. The keyboard circuit should be isolated from the loop and use either contacts or an NPN switching transistor to ground. The separate keyboard data is sensed by the KOS circuit and therefore all KOS features are available with this connection. Note, however, that a jumper on the AUXILIARY jumper plug should be removed for separate keyboard data input: carefully cut the path on the AUXILIARY jumper circuit board between pins 1 and 5 with a sharp knife or scribe.

3.3.3 Full Duplex Operation of the ST-6000

The receive (demodulator) and transmit (tone keyer) sections of the ST-6000 are normally interconnected with the standard cables and jumpers so that all keyboard generated data automatically drives the transmit data circuits to use a "full-duplex" mode of operation. To connect the ST-6000 for full-duplex operation, remove the jumpers on the AUXILIARY jumper plug between pins 1 and 5 and between pins 11 and 15. Add a jumper to the AUXILIARY jumper plug between pins 14 and 15. The separate keyboard should now be connected as described above in section 3.3.3. Received data will now be displayed on the printer or visual display system but will NOT key the tone keyer section. Keyboard data will trigger the KOS circuit and key the tone keyer section. The same connections can be used for full-duplex operation with either RS-232 or MIL-188 signal levels if the appropriate connections on the rear panel connector are selected. Connection of the separate keyboard, and full-duplex jumpers are shown in Figure 3.6. Since the KOS circuit also places the ST-6000 in standby condition, KOS should be switched OFF for true full-duplex operation.

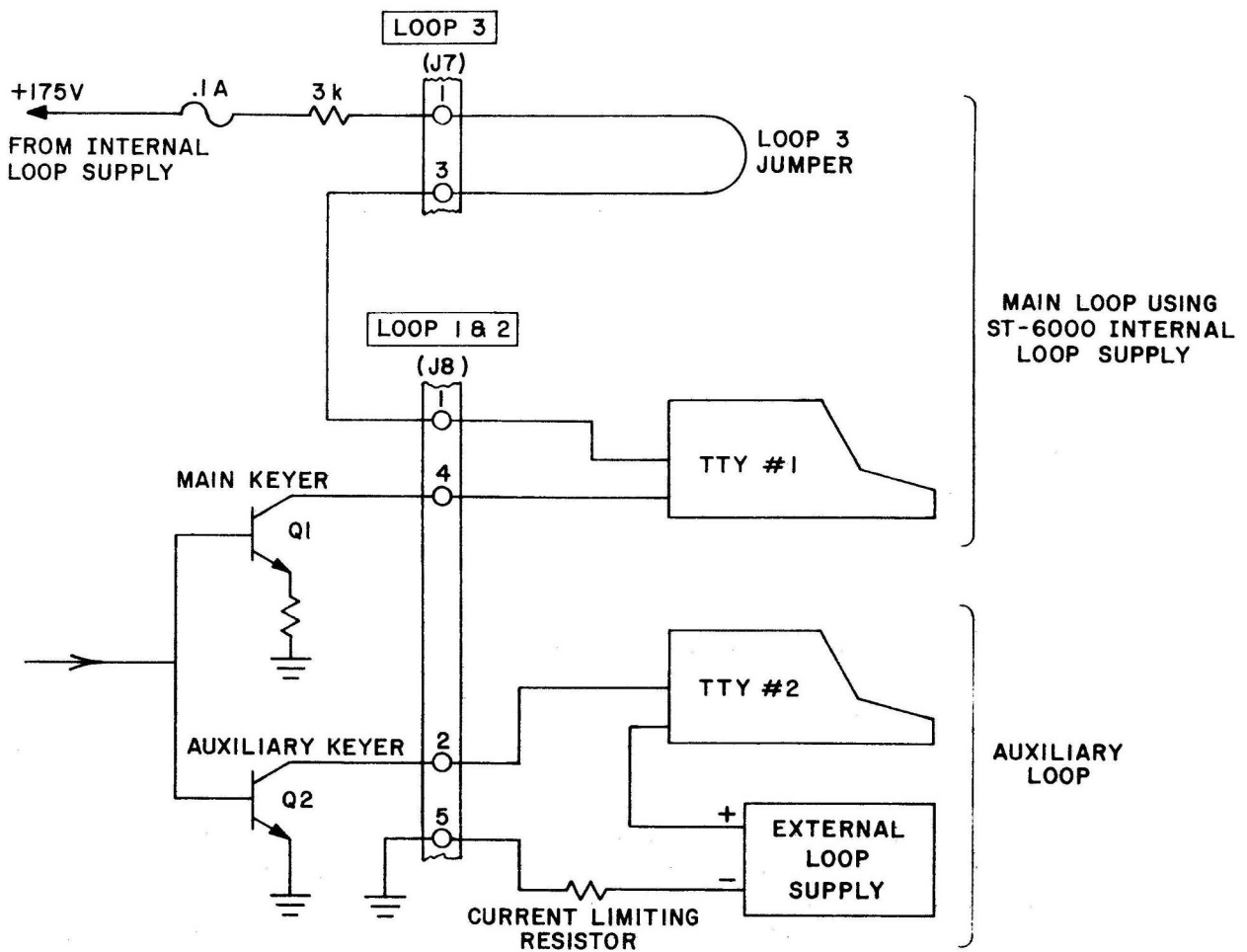

USE OF INTERNAL AND EXTERNAL LOOP SUPPLIES

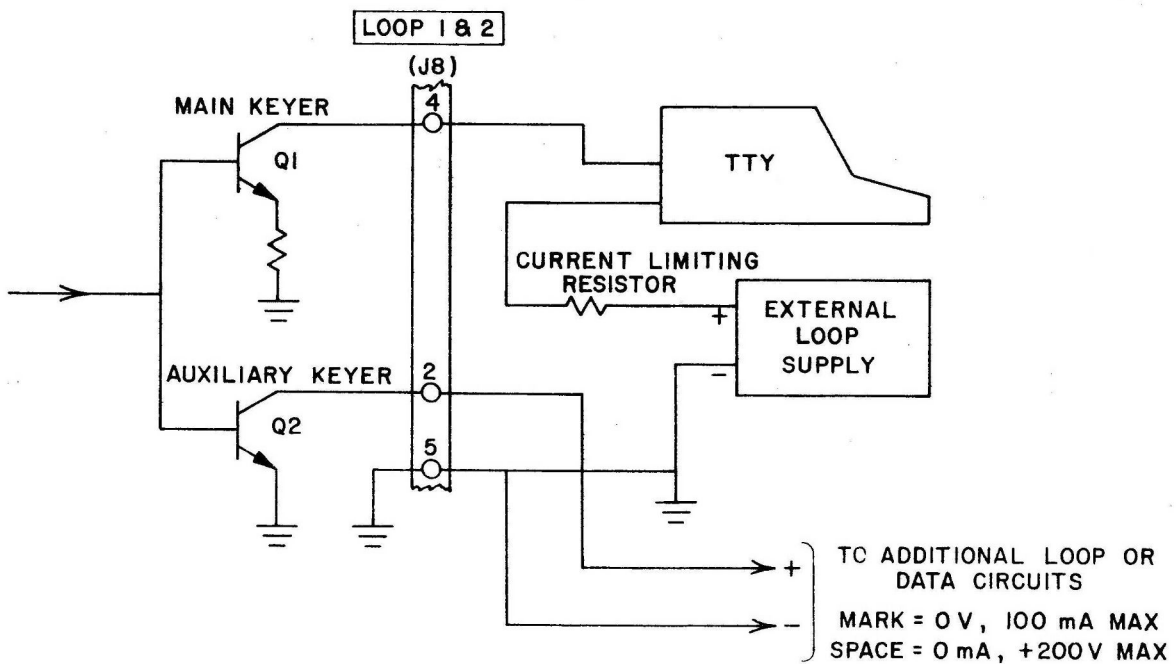

USE OF EXTERNAL LOOP SUPPLY ONLY

Figure 3.5 Alternate Loop Connections

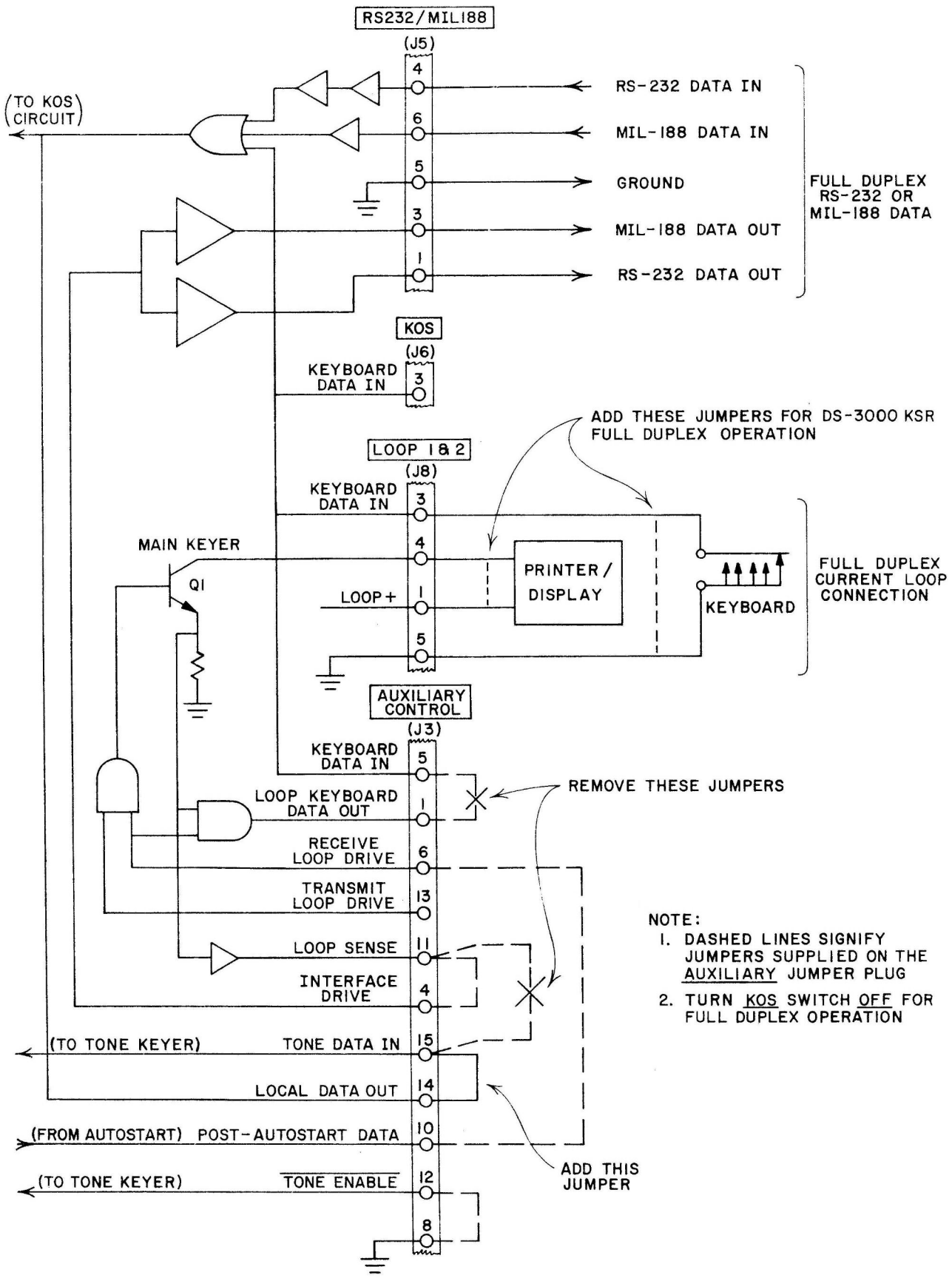

Figure 3.6 Connections for the ST-6000 for Full-Duplex Operation

3.3.4 External Data Processing Equipment

Since both the pre- and post-autostart data signals as well as the inputs to the loop keyers are available on the AUXILIARY connector, external data processing equipment can be connected between the ST-6000 demodulator and keyer circuits. This feature allows connection of such external devices as the various popular UART devices, digital autostart, electronic stunt boxes, speed converters, and so on. The external equipment should be compatible with the CMOS integrated circuits used in the ST-6000 and should include its own, separate power supply. The +12 Volt connection on the AUXILIARY connector can be used for "reference" or "pull-up resistor" applications ONLY. Be sure to use adequate shielding and RF by-passing to prevent the feed-back of spurious RF energy into the ST-6000.

An external data processing device can be connected to the ST-6000, using either the unconditioned data (Pre-autostart Data) or autostart conditioned data (Post-autostart Data) as the device input signal and then routing the device output signal back to the ST-6000 I/O driver circuits. ALL ST-6000 external data and control circuits use CMOS compatible levels of 0 and approximately +12 Volts. All data circuits have the convention of MARK = 0 Volts and SPACE = +12 Volts. Control circuits are labeled using positive-true logic conventions (thus, Remote Standby is in standby with 0 Volts applied and in receive with +12 Volts applied). The user may wish to make-up his own AUXILIARY connector plug with the pins and shell provided rather than make extensive modifications to the AUXILIARY jumper plug circuit board. A typical connection to a UART device is shown in Figure 3.7.

Obviously, a great many other I/O and control connections can be made. The user should thoroughly study section 5 and understand how the various sections of the ST-6000 operate and interact before these connections are made.

3.3.5 External Oscilloscope Connections

The MARK and SPACE AC signals are available on the rear panel SCOPE connector. The signals are approximately 2.0 Volts peak-to-peak amplitude into a recommended 100-kOhm minimum load impedance. The MARK signal is available on pin 3, the SPACE on pin 1, and signal ground on pin 2.

3.3.6 Tone Keyer Control Connections

As noted in section 3.3.3, the ST-6000 tone keyer is normally connected for half-duplex operation when the AUXILIARY jumper plug is used. With this connection, the tone keyer is driven by any data that keys the loop, whether it is received data or from keyboard (or TD) interruptions of the loop. Under these conditions, the tone keyer output is ALWAYS present and repeats the input to the demodulator when receiving. Thus the ST-6000 acts as a repeater, processing the data in the demodulator and regenerating noise-free tones in the keyer section. This is a particularly convenient feature if it is desired to record the signal on an audio recorder (for autostart recording, for instance) or to repeat the signal on another communications link. (Use of the ST-6000 in a TTY repeater would be further enhanced if the received data is first coupled through a UART digital data regeneration circuit before driving the tone keyer section.)

There are, however, instances when it is desirable to be able to separate the transmit and receive functions of the ST-6000 (as described in section 3.3.3) or turn-off the tone keyer circuit externally. The output of the tone keyer can be externally controlled with the TONE ENABLE signal, available on pin 12 of the AUXILIARY connector. As indicated by the labeling, this is an inverted control signal, 0 Volts = tone on and +12 Volts = tone off. As noted earlier, this control line should be driven by CMOS compatible signals. If the tone output is only required during transmit, the KOS

ON signal (pin 9, J3) can be connected to TONE ENABLE (pin 12, J3), taking care to first remove the jumper between pins 8 (ground) and 12 of the AUXILIARY connector (J3). In this case, the KOS circuit will actuate the tone keyer output.

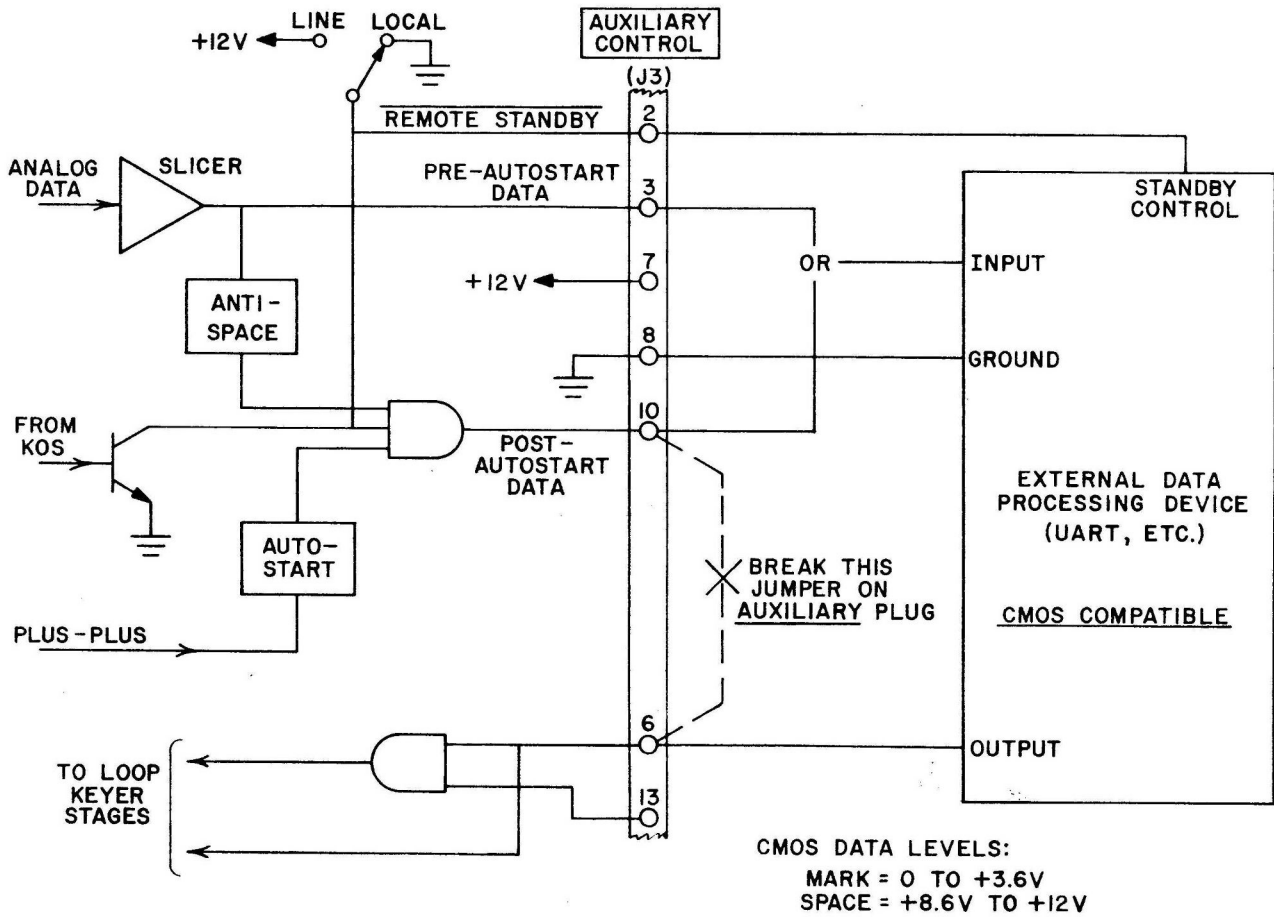

Figure 3.7 Connection to External Data Processing Devices

4. OPERATING

The ST-6000 contains many advanced features designed to allow operating conveniences previously unavailable in FSK demodulators. The operating instructions presented in this section will help you to take full advantage of the demodulator's capabilities. Please read all sections carefully.

4.1 Front Panel Controls and Indicators

The ST-6000 front panel has a total of twelve push-button switches that allow operator control of the demodulator. Normal operation of the demodulator with ALL automatic features active is obtained by depressing all six of the right-hand bank of switches and the right-hand three switches of the left bank. One of three far left-hand switches should be depressed to select the desired shift. These functions will be discussed in greater detail later in this section and in section 5. Tables 4.1 and 4.2 describe the front panel switches and indicators.

SWITCH	POSITION	FUNCTION
POWER	ON - OFF	Controls AC power to ST-6000
AUTOSTART	ON - OFF FAST - SLOW	Turns autostart circuit on or off Selects autostart response time (1 or 3 sec.)
KOS	ON - OFF	Turns KOS circuit on or off
PRINT	LINE LOCAL	Allows received data to drive printer Locks printer in mark for "local-loop" operation
DTH	ON - OFF	Turns DTH circuit on or off
ATC	ON - OFF	Turns ATC circuit on or off
SENSE	NORM REV	Normal signal polarity; mark = lower tone Reverse signal polarity; mark = higher tone
LIMITER	ON - OFF	Turns limiter stage on or off
SHIFT (Hz)	170 425 850	Selects 170 Hz shift Selects 425 Hz shift Selects 850 Hz shift
Oscilloscope	INT FOC VER HOR	Adjust oscilloscope trace intensity Adjust oscilloscope trace intensity Adjust oscilloscope vertical position Adjust oscilloscope horizontal position

Table 4.1 ST-6000 Front Panel Controls

INDICATOR	FUNCTION
POWER	Indicates AC power on when lit
AUTO	Indicates when the autostart circuit will allow passage of the data to the printer. This lamp is on whenever the autostart senses a valid TTY signal OR if the AUTOSTART switch is OFF.
MARK	Indicates marking condition on the pre-autostart data output from the slicer stage.
KOS	Indicates that the KOS circuit is in TRANSMIT mode.
SPACE	Indicates that the post-autostart data is in space condition.
LOOP	Indicates marking condition in the LOOP 1 circuit.
OSCILLOSCOPE	Indicates tuning of receiver.

Table 4.2 ST-6000 Front Panel Indicators

The rear panel connectors have been discussed in detail in section 3 and internal adjustments will be discussed in detail later in this manual.

4.2 Simplified Operating Procedure

The following procedure is suggested for those operators who are anxious to try the ST-6000 without reading the rest of this manual.

1. Use the "standard" cables and jumper plugs supplied with the ST-6000 to connect the unit to a receiver and printer or display as described in section 3.2. DO NOT CONNECT A TRANSMITTER WITHOUT READING THE REST OF SECTION 4 OF THIS MANUAL.
2. AFTER CONNECTIONS ARE MADE, plug-in the ST-6000 and other equipment and turn-on the AC power to each.
3. Set the ST-6000 switches as follows:
 - POWER - ON
 - AUTOSTART - OFF, FAST or SLOW
 - KOS - OFF
 - PRINT - LINE
 - DTH - OFF
 - ATC - ON
 - SENSE - NORM
 - LIMITER - ON
 - SHIFT - select desired shift
4. Set the receiver to LSB mode and tune to a FSK RTTY signal. (Approximately 3600 kHz at night and 14.000 kHz during the day are good frequencies to look for 170 Hz shift radio amateur RTTY signals at 60 WPM.)
5. Tune the receiver dial until perpendicular ellipses are displayed on the oscilloscope screen.
6. The printer should now print the received signal. If it doesn't, try reversing the SENSE switch or selecting different speeds on the printer or display.
7. NOW, read the rest of this manual!

4.3 Reception of Radio Teleprinter Signals

Radio teleprinter signals are usually generated in two forms: direct shifting of the transmitter carrier frequency by the mark and space teleprinter data (called "FSK") or by shifting the frequency of audio tones with the data and using the audio tones as modulation in either an AM or FM transmitter (called "AFSK"). FSK transmissions are usually used in the HF frequency range, below 30 MHz and AFSK is the normal technique for VHF transmissions, above 30 MHz. A currently popular method used to transmit FSK signals is to apply the frequency-shifted tones as modulation to a single-side-band (SSB) transmitter. Since a properly adjusted SSB transmitter signal is the same as that by direct FSK, a separate RF frequency for mark and space data conditions. Reception of such signals is therefore exactly the same as if direct FSK, had been used. Use of this technique will be discussed in greater detail in section 4.13.

4.3.1 Receiver for FSK Reception

The performance of the ST-6000 depends to a great extent upon the characteristics of the receiver used and the care taken in tuning the FSK signal. Obviously, the better suited the receiver, the better the quality of the printed displayed output. Some of the desirable receiver characteristics and features are:

1. The receiver should preferably be of the SSB type with selectable sideband. Standard convention is to use LSB mode for FSK reception.
2. The frequency stability of the receiver should be very good – a small amount of drift when receiving a 170 Hz shift signal can cause poor print from even very strong signals.
3. The tuning ratio of the main tuning knob should be slow to allow precise adjustment of the FSK signal into the receiver.
4. The selectivity of the receiver should be slightly greater than the shift to be received: for 850 Hz shift, a bandwidth of 1200 to 2100 Hz is adequate; for 170 Hz shift, a bandwidth as narrow as 400 Hz can be used. Two limitations should be kept in mind, however; the narrower the bandwidth, the greater the frequency stability requirements on the receiver, and wider bandwidths permit more interference and noise to be processed with the FSK signal.
5. A "slow" AGC with fast attack and slow decay is very desirable when receiving FSK signals.
6. As mentioned in section 3.2.1, a 500 Ohm audio output connection or speaker to 500 Ohm transformer are highly recommended for connection to the ST-6000 input.
7. An adjustable BFO frequency or adjustable pass-band tuning are very desirable features for reception of FSK signals.

Proper positioning of the receiver's BFO with respect to the IF pass-band and the FSK signal is particularly important. The standard convention when transmitting HF FSK signals is to transmit mark data at the higher RF frequency and space at the lower. The separate mark and space RF frequencies are both received within the receiver IF pass-band and mixed in the product detector with the BFO to produce audio tone beat signals which then drive the ST-6000. Since the audio filters of the ST-6000 follow the demodulator standard of mark being the lower frequency audio tone, it follows that the BFO of the receiver should be HIGHER in frequency than the FSK signal. This corresponds to use of the LSB (lower side-band) mode of the receiver. However, if the signals is inadvertently tuned-in using USB (upper side-band) mode, the sense can be corrected with the SENSE switch on the ST-6000 front panel.

The receiver BFO frequency positioning also determines the RANGE of audio frequencies that can be detected and used to drive the ST-6000. The normal SSB receiver has generally been designed for optimum performance with voice signals with a typical audio frequency pass-band of 300 to 2400 Hz. However, the so-called "standard" demodulator audio tones have been 2125 Hz for mark with the space tone higher in frequency by the amount of the shift received. For 170 Hz, both the mark (2125 Hz) and space (2295 Hz) tones fall within the 300 Hz to 2400 Hz pass-band,

although they are not centered. The 425 Hz shift space-tone at 2550 Hz may or may not be detected by the receiver and the 850 Hz shift space tone at 2975 Hz is not detected for all but the strongest FSK signals. Obviously, the 425 Hz and 850 Hz shift FSK signals are NOT compatible with the usual SSB receiver if the "standard" demodulator tones are used. There are two solutions commonly applied to this problem, both of which are usable with the ST-6000.

One solution is to simply change the receiver BFO frequency so that the audio pass-band of the receiver is changed to, say 1500 Hz to 3600 Hz, which will pass all of the "standard" demodulator tones, centering the pass-band on the 850 Hz shift signal. In this case, the BFO frequency should be changed so that it is FARTHER AWAY FROM THE CENTER OF THE IF PASS-BAND by approximately 1000 to 1400 Hz. If the receiver BFO is adjustable, this is a simple solution. However, many modern SSB receivers do NOT have adjustable BFOs; rather, the BFO may be crystal controlled. In such cases, the BFO crystal should be changed for one of the correct frequency as determined above. Alternately, the second solution, outlined below, may be used.

The receiver audio pass-band problem can also be solved by changing the tones used by the demodulator for detection of mark and space. This technique, commonly referred to as "low-tones" allows direct use of a voice SSB receiver with no internal modifications to the receiver. The ST-6000 can be furnished with filters designed to accept a mark frequency of 1275 Hz and therefore space frequencies of: 1445 Hz (170 Hz shift), 1700 Hz (425 Hz shift) or 2125 Hz (850 Hz shift). In some cases, this can be the best solution. However, as discussed in the next section, it can lead to a basic incompatibility when receiving AFSK VHF signals as well as presenting some transmitter problems. The ST-6000 can also be adjusted for special sets of input tones between 1200 and 3000 Hz on special order.

4.3.2 Receiver for AFSK Reception

The receiver requirements for AFSK reception are not as exacting as those for FSK reception. Since the teleprinter data is an AFSK modulation of the transmitter, receiver stability is not generally critical. However, since the data is in the form of audio frequency modulation, the frequency of the tones is determined at the transmitter and cannot be changed at the receiver by simply adjusting a BFO or similar control. The current VHF-AFSK standards in use by radio amateurs in the United States use the higher-frequency "standard" tones of 2125 Hz for mark and 2295, 2550 or 2975 Hz for space, depending upon the shift used. Therefore, a demodulator with "low-tone" input filters will NOT be compatible with reception of current VHF-AFSK signals. As in the case of the FSK receiver, a 500 Ohm audio output is certainly desirable, but may not be as important to performance, particularly if strong-signal VHF-FM signals are used.

4.3.3 Tuning a RTTY Signal

Tuning of the radio receiver for optimum recovery of the teleprinter signal is an operation which may require some practice. The tuning objective is to adjust the receiver tuning so that the output audio tones match the center frequencies of the ST-6000 filter circuits, as indicated on the tuning oscilloscope.

The oscilloscope takes the place of a tuning meter in the ST-6000. The oscilloscope presents the standard crossed-ellipse display with the mark signal on the horizontal axis and the space signal on the vertical axis. Because the discriminator filters in the ST-6000 (like those of the ST-5 and ST-6) are relatively broad-band, the mark and space scope displays are NOT lines, but ellipses. The ellipses are fairly narrow when 850 Hz shift is received and wider when 170 Hz is selected. When the RTTY signal is correctly tuned, the ellipses will have maximum length and be essentially perpendicular. The major axis of the ellipse is ALWAYS the parameter to observe and maximize.

When the signal is incorrectly tuned, the amplitude of the major axis will be reduced and the two traces may be rotated and/or no longer perpendicular. After using the tuning oscilloscope, the user will discover that, in many cases, the trace positions and amplitudes can be used to determine which direction the receiver dial should be adjusted for correct tuning.

Proper tuning adjustment of the receiver is much more critical when the autostart circuits of the ST-6000 are active than when they are not. This is because the autostart circuitry senses the "plus-plus" voltage which is quite sensitive to the centering of the signals in the discriminator filters. However, if the autostart is not active, the relatively broad bandwidths of the discriminator filters themselves will allow good reception of even poorly tuned RTTY signals. A good operating procedure, then, is to turn the autostart OFF (with the front panel switch) while tuning a signal. When the signal is correctly tuned, the autostart can be activated, if desired. This technique is highly recommended for operators who are unfamiliar with the ST-6 and ST-6000 autostart circuits although, with practice, you may prefer to tune with the autostart circuit on to avoid the garbled print while tuning. Tuning when the autostart is active requires experience and faith in the tuning indicators since there is a delay of 1.5 to 3.5 seconds after correct tuning is achieved before the printer is activated.

The above tuning procedures in general apply only to the reception of FSK RTTY signals. Receiver tuning of AFSK-AM or FM signals will obviously not affect the frequency of the tones. Therefore, tuning of the receiver is not at all critical for AFSK signals. The tuning meter or oscilloscope will indicate the match between the transmitted audio tones and the ST-6000 discriminator filter rather than correct receiver tuning. Obviously, the frequencies of the transmitted tones must match the discriminator filters fairly well for satisfactory autostart operation. Most problems with AFSK autostart systems can be traced to either off-frequency transmitter tones or misalignment of the demodulator. The ST-6000 should NOT have these problems since the frequencies of the transmitted tones are crystal controlled and the discriminator filters are aligned to these same crystal-controlled tones.

4.4 Use of the ATC Circuit

The ATC (Automatic Threshold Control) circuit is designed to provide a degree of correction for bias distortion which may be caused by the propagation of the signal. It is most useful when using the "AM" mode of the demodulator (LIMITER switch OFF), but can also be used in an "FM" mode of demodulator operation (LIMITER switch ON). The ATC circuit should generally be used only when receiving a signal that is transmitted at close to the maximum data rate for the given speed (transmitted at close to the "tape rate"). The ATC can cause distortion to signals that are hand-typed and it should be switched off if problems are encountered with printing hand-typed signals. The distortion is, however, minimal in most cases and the ATC circuit can remain ON for most applications (as it is in the ST-6 demodulator).

4.5 Use of the DTH Circuit

The DTH (Decision Threshold Hysteresis) circuit will provide correction for distortion caused by multiple-path propagation of RTTY signals. When the signal between a transmitter and receiver is ionospherically propagated over more than one path, the lengths of these paths are usually quite different. Therefore, the propagation time for each path is different. When these various signals are summed in the receiving antenna, the antenna voltage can vary over a wide range (phase addition and cancellation) or the transition time from mark to space (or vice-versa) can be distorted. The voltage variations (or fading) is neutralized in the high-gain limiter and detector circuits of the ST-6000. The indeterminate transition time, however, can cause distortion and misprinting of the RTTY signal. The DTH circuit provides enough hysteresis in the slicer stage to require a definite

change of signal state before the slicer and therefore loop keyer stages are allowed to switch. This multi-path distortion phenomena is usually not iced only on signals from very high-powered transmitters and therefore will NOT be a problem when receiving most radio amateur RTTY signals. Therefore, unless the ST-6000 is used to receive signals from known very highpowered transmitters, it is recommended that the DTH circuit be left OFF until multi-path distortion is suspected.

4.6 Use of the Limiter Switch FM vs. AM

The ST-6000 has been designed for optimum performance when the input signals are "hard-limited" (FM mode, LIMITER ON). To this end, a very high-gain limiter stage, wide-dynamic range input filters, and wide bandwidth discriminator filters are used in the demodulator. For MOST applications, the FM or LIMITER ON mode will provide superior performance due to the quieting and capture-effect of a "hard-limited" FM receiver circuit. However, a limiter has a minimum threshold, below which it is captured by the noise rather than the signal and the limiter will also be captured by the STRONGEST signal within its bandpass. Therefore, there is at least a theoretical advantage to using a non-limited, "AM" type of detection system for very weak signals or in the face of heavy interference. When the LIMITER switch is turned OFF, the gain of the limiter is reduced so that it becomes a linear amplifier. In this mode, the pre-filter AGC circuit and the active discriminator detectors provide a wide dynamic range, almost as great as that achieved when the limiter is turned on. Although the ST-6000 performance in AM mode exceeds that of the previous model ST-6 demodulator, the actual improvement in print may or may not be noticed, depending upon the receiving conditions. It is recommended that the ST-6000 be used with the LIMITER ON for most applications and the AM mode used only in the face of strong interference or very weak signals. Use of higher-gain directive receiving antennas will generally improve weak-signal performance more than could be achieved with limiter-less RTTY demodulation.

4.7 Use of the SENSE Switch

The SENSE switch allows the ST-6000 to receive signals with either the normal polarity of mark=lower frequency or the reversed sense where mark=higher frequency tone. ALL features of the ST-6000 function equally well for either signal polarity. This reverse position is convenient if the signal has been inadvertently tuned-in using USB rather than LSB receiver mode. Unlike the previous model ST-5, BOTH the discriminator filters AND the tone generator frequencies are controlled by this switch, assuring true transceive conditions for both polarities.

4.8 Use of the PRINT Switch

There are many occasions in which it is desirable to turn-off the received data to the teleprinter loop circuit and just use the internal loop supply to operate the RTTY machines at the station. Operations such as local testing of equipment or preparation of punched paper tape are typical examples. When the PRINT switch is in LINE position, data from the receiver is allowed to key the loop circuit. When the switch is in LOCAL position, the loop keyer stages are held in mark condition and received data will NOT drive the loop. This circuit is also operated whenever the KOS circuit is in transmit mode to prevent feed-back of the transmitted signal back through the demodulator. The demodulator can also be held in LOCAL position by grounding the REMOTE STANDBY line on pin 2 of the AUXILIARY connector (J3). Note that, as per the discussions of section 3.3, the PRINT switch or REMOTE STANDBY line actually control the post-autostart data output. When the AUXILIARY jumper plug furnished is used, the Loop 1 circuit is also controlled. If, however, an external device such as a UART circuit is connected between the pre-autostart data output and a keyer stage, the loop status is NOT controlled by either the PRINT switch or the REMOTE STANDBY line.

In this case, the user will have to make his own, separate provisions for control of the received data during transmit.

4.9 The KOS Circuitry

The ST-6000 includes an automatic transmit-receive circuit that functions in a manner very similar to that of a VOX circuit in a SSB transmitter. This is the KOS (Keyboard Operated Switch) circuit. The KOS circuit senses and differentiates between received data (from the demodulator section) and data to be transmitted (from the keyboard, tape distributor, etc.). Whenever transmit data is sensed, the KOS output keying transistor is turned "on" (low impedance to ground). If the PTT (Push-To-Talk) line of the transmitter is connected to the KOS line of the ST-6000, the transmitter will automatically go on whenever transmit data is sensed. Also, the KOS circuit senses the status of the CW-ID input to the tone keyer and stays in transmit mode as long as the CW-ID key is active. The operation of the KOS circuit is as follows:

1. The KOS is turned "on" (transmit condition) when:
 - a. The keyboard circuit goes to space condition (open circuit) for more than approximately 5 ms.
 - b. The CW-ID key is closed.
2. The KOS is turned "off" (receive condition) when:
 - a. The keyboard circuit remains in space condition for more than 0.5 second.
 - b. The keyboard circuit remains in mark condition for an adjustable time period between 1 and 10 seconds.
 - c. One second after the last CW-ID key closure.

The connections on the standard AUXILIARY jumper plug supplied with the demodulator allow the keyboard and printer to be series-connected in the same loop. In this case, the logic of the KOS circuit senses whether the loop has been interrupted by a received signal or by the keyboard (or other, external device in the loop). The KOS is only allowed to turn-on (transmit mode) when the loop interruptions are NOT caused by receive signals. Thus, the ST-6000 KOS circuit does not necessarily require separate keyboard and printer connections as have previous similar circuits. If the AUXILIARY jumpers are changed, a separate keyboard circuit can be used to trigger the KOS or the presence of either RS-232 or MIL-188 input data can also be used trigger the KOS circuit.

When the KOS is used, typing on the keyboard will turn the transmitter on and inhibit the data drive to the loop keyer stage. Use of the CW-ID key will also turn the transmitter on or keep it on, as the case may be. The transmitter can be turned off rapidly by simply holding down the break key for more than 0.5 sec. or by pausing for more than the preset time (1 to 10 sec.). The KOS mark-hold time is adjusted with a potentiometer mounted on the control board directly behind the midpoint between the AUTOSTART ON-OFF switch and the KOS switch. The potentiometer is in the second line of ICs back from the front panel.

In order to avoid distortion of the first character typed, it is recommended that the transmission be started with some non-essential character, such as a blank or space. If it is not desired to use the KOS circuit, turn it off with the front panel switch provided. When connecting the KOS transistor to the PTT line, be sure to observe the voltage and current limitations given in section 3.2.5.

4.10 Use of the Autostart Circuitry

The ST-6000 autostart circuit operates in a manner very similar to that of the ST-5 and earlier TT/L and TT/L-II demodulators. The autostart provides a two-step control of the printer mark-hold and control of the AC power to the printer motor. The autostart circuit senses the voltage on the "plus-plus" line, which is, as described previously, proportional to the frequency match between

the signal tones and the discriminator filters. If both mark and space tones are not sensed in the discriminator, the "plus-plus" voltage remains at a low average value and the autostart circuit will be in the standby condition, giving a continuous mark output. After the autostart has remained in the standby or mark-hold condition for 20 seconds (nominal), the power to the MOTOR AC socket on the rear panel is turned off with an internal relay. If valid mark and space tones are now sensed in the discriminator, the "plus-plus" voltage will increase and activate the autostart after a delay of either 3.5 seconds (AUTOSTART - SLOW) or 1.5 seconds (AUTOSTART - FAST). The AC power to the MOTOR connector is now switched on and the data is allowed to drive the post-autostart data line. Immediately after the tones turn-off at the end of a transmission, the autostart returns the post-autostart data to mark hold, completing the cycle.

Because of the turn-on delay inherent in the autostart, it is recommended that tuning of the RTTY signal be done with the AUTOSTART switch in the OFF position during initial testing of the ST-6000. After the operator has some practice in tuning the receiver, he may then wish to leave the autostart circuit ON, remembering to account for the time delay of the autostart.

The autostart trigger voltage level on the "plus-plus" line is adjustable with a potentiometer mounted on the control circuit board inside the ST-6000 cabinet. The potentiometer is located behind and slightly to the left of the KOS front panel switch and is labeled "AUTO" on the circuit board. Rotation of the screw-drive adjustment CCW decreases the "plus-plus" voltage required to trigger the autostart, thus INCREASING the autostart SENSITIVITY. Conversely, CW rotation decreases the autostart sensitivity. This control is normally set at the factory to trigger the autostart on all signals giving a tuning meter reading of 0.5 and higher. The user may adjust this control to fit his own requirements. If the autostart sensitivity is set too close to the noise level, false printing may occur on noise or interfering signals; if set to too high a level, the autostart may not trigger on all but the strongest signals with exactly correct shift. Experience will determine the optimum setting for a particular system. Notice that the "plus-plus" voltage and therefore autostart sensitivity are directly proportional to the degree of match between the signal tone frequencies and the center frequencies of the discriminator filters. It may therefore be difficult to set the autostart sensitivity and receiver tuning to respond to signals with improper frequency shift. Also, if the transmitter OR receiver should drift, the signal tones will soon no longer match the discriminator filters, causing the autostart to "shut-down". If drifting is a problem, the receiver should either be monitored often and manually retuned as required or the autostart should be switched OFF.

4.11 Antispace Circuit

Like the ST-5, the ST-6000 incorporates a timing circuit that prevents the continuous spacing condition (machine "running-open") in the post-autostart data output if a space tone longer than approximately 250 ms is received. When a long space condition is detected, the antispace circuit activates the mark-hold circuitry. A continuous space will NOT turn the motor power off. The anti-space circuit is always active, but ONLY controls the post-autostart data output. The pre-autostart data output is NOT controlled by the anti-space, autostart, or standby circuits.

4.12 Tone Keyer Circuit

The ST-6000 includes a crystal-controlled tone keyer that is very similar in design to the previous HAL model XTK-100 tone keyer board. All mark, space and CW-ID tones are digitally synthesized from high-frequency crystal oscillators. The crystal frequencies are either 2000 or 3000 times the desired output tone frequency. Unlike previous tone keyers, the ST-6000 CW-ID tone is generated at 100 Hz BELOW the mark tone instead of above. This further reduces the chances of falsely triggering the autostart of the receiving demodulator, even when 170 Hz shift is used. Also, the sense of the ST-6000 tones is changed with the demodulator SENSE (NORM-REV) switch, thus per-

mitting transceiver operation with either polarity, lower tone mark OR higher tone mark. The tone keyer can be driven from separate keyboard data, from a current loop, or other sources as explained in section 3. The output of the tone keyer can also be turned on or off with a remote control as explained in section 3.3.6. The tone output amplitude can be adjusted over the range of 0 to -40 dBm (approximately 1.0 V to 10 mV across 500 Ohms) with an internal potentiometer. The amplitude is adjusted with the TONE LEVEL potentiometer, located on the input circuit board, approximately two inches directly behind the ATC front panel switch. This adjustment works exactly the reverse of a volume control full CW is minimum output amplitude and full CCW is maximum output. Although the output impedance of the tone keyer is 500 Ohms, virtually any load impedance from 500 Ohms to several Megohms can be driven by the ST-6000. It is NOT necessary to terminate the audio output connector in a 500 Ohm load.

4.13 Transmitting Radio Teleprinter Signals

As mentioned previously in section 4.3, radio teleprinter signals are generated by either shifting the transmitter RF frequency with the data (FSK) or by modulating the transmitter carrier with audio tones whose frequencies are shifted by the data (AFSK). Usually, FSK transmission is used for radio frequencies lower than 30 MHz and AFSK above 30 MHz. The ST-6000 can be used to receive AND transmit both FSK and AFSK types of signals.

4.13.1 Transmitting FSK Signals

There are two different techniques that are normally used to generate a FSK teleprinter signal. The simplest method involves direct shifting of the frequency of an oscillator stage in the transmitter. Typically, the data signal is used to turn on or off a diode switching circuit that effectively increases the oscillator tuned circuit capacitance on space, thus lowering the transmitter frequency for space condition of the data. A typical diode keyer circuit is shown in Figure 3.3. Note that the RS-232 or MIL-188 data outputs are ideally conditioned for this application. Since one is the inverse of the other, the mark-space sense or polarity can be changed by selecting either RS-232 or MIL-188 outputs. Further information on this type of circuit can be found in a current edition of the [Radio Amateurs Handbook](#) (ARRL, Newington, Conn.) or in the [Radio Handbook](#) (Ore, Howard W. Sams, Inc., Indianapolis, Ind.), or other text on radio transmitters. The standard radio amateur polarity convention is, to make the mark frequency higher in frequency than the space frequency, although a number of exceptions are to be found, particularly in commercial applications.

A second technique to generate FSK uses a SSB type of radio transmitter. The AFSK tone output from the tone keyer is used as the audio modulation of the transmitter. Since a properly adjusted SSB transmitter suppresses one sideband and the carrier of the AM signal, the RF output for a single frequency tone input is simply an RF carrier, displaced from the original carrier frequency by the tone frequency. When the tone frequency changes, the RF output frequency also changes by the same amount. Historically, the audio tone standard has been to designate mark as the lower frequency AUDIO tone and space as the higher. Thus, to achieve "normal" FSK RF output with mark as the higher RF frequency, the LSB (lower sideband) mode is used in the SSB transmitter (and receiver as explained in section 4.3). This technique is often mistakenly called the "AFSK-SSB" or simply "AFSK" method. However, the end result is exactly the same as if the transmitter were directly frequency shifted by the data and "FSK" is the true description of the RF signal generated.

At first glance, this SSB method is very attractive; it requires no internal modification to the transmitter and can use readily available SSB transmitters. However, there are a number of precautions that must be traced to the basic fact that SSB transmitters have been specifically designed to transmit voice signals and the performance and specifications are optimized for voice applications. The first conflict in specifications is in the duty-cycle rating of the transmitter. The duty-cycle of the

typical voice is at best 50 % (less compressors, etc.) while a RTTY transmission has a 100 % duty cycle. SSB transmitter power amplifier stages are usually designed to take advantage of the reduced duty cycle of a voice signal to produce relatively high output powers in small enclosures with proportionally smaller power supplies. If the same SSB transmitter is operated in RTTY service at full voice ratings, the output amplifier and/or power supply will usually fail. Therefore, the SSB transmitter rating must usually be reduced by at least 50 % when 100 % duty-cycle RTTY transmission is used. There are a few commercially available SSB transmitters that will accommodate RTTY at full power, usually with the addition of a blower or heavy-duty power supply. The user should carefully check the rating of his SSB transmitter before using it in RTTY service.

Another problem often encountered when the tones are used with a SSB transmitter is very similar to the BFO-passband problem previously discussed in section 4.3.1. Since the SSB transmitter is designed to transmit the voice frequency range of 300 to 2400 Hz, it follows that some of the standard "high-tones" will NOT be transmitted, particularly the 2975 Hz space tone for 850 Hz shift. As with the SSB receiver, there are two ways to solve this problem, shift the carrier oscillator frequency with respect to the filter passband, or use lower frequency tones. The same procedure used to change the receiver BFO frequency can be used to change the transmitter carrier oscillator frequency. This may even be less convenient to do in the transmitter than the receive since it usually involves changing a crystal in the transmitter. Use of the "low-tone" set of keyer frequency is always the simplest solution. However, use of the "low-tones" should be done with care for the following reasons:

1. SSB transmitters generally have no more than 55 dB of carrier rejection when properly aligned. If the balanced modulator has not been recently readjusted, the carrier rejection may well be no more than 25 to 35 dB. Transmission of a small amount of carrier with a SSB voice signal is not usually objectionable. However, when the SSB transmitter is used to transmit RTTY signals, the unsuppressed carrier is now a spurious emission which is illegal and may cause receiving problems. In general, the carrier suppression and adjustment stability of a PHASING-TYPE of SSB transmitter is even worse and this type of transmitter should NOT be used to generate RTTY signals.
2. When the "low-tones" are used, the mark frequency is 1275 Hz. If there is any distortion in the SSB transmitter audio or modulator, the second harmonic may be generated, causing radiation of still another spurious signal.
3. The present convention for AFSK-VHF transmission of RTTY signals in the United States is to use the "high-tones", 2125 Hz mark and 2295, 2550, 2975 Hz space tones. A demodulator set-up for "low tones" is NOT compatible with this application.

Conversely, if the transmitter carrier oscillator is shifted so that the standard "high-tones" can be used, the carrier rejection is greatly increased, audio distortion products generated in the transmitter do NOT fall within the transmitter filter passband and the demodulator is then usable for BOTH FSK and AFSK applications. Note that 170 Hz shift with "high-tones" can be used without changing the transmitter carrier oscillator since both 2125 Hz (mark) and 2295 Hz (space) fall within the voice passband. However, the carrier rejection will be no better than it is for a voice transmission.

Alternately, the following points FAVOR the use of the "low-tones":

1. The current IARU international standards call for use of "low-tones"
2. The "low-tones" have been successfully used in commercial and military applications for some time with satisfactory results.
3. If the precautions noted above regarding carrier rejection and transmitter audio distortion are observed, the total system performance using "low-tones" can be just as satisfactory as a system using "high-tones".

The "optimum" choice between the two tone sets will vary with the application intended and the preferences of the user. It is hoped that the previous discussion will help alleviate some of the confusion that exists concerning the use of "low-" vs. "high-tones".

4.13.2 Transmitting AFSK Signals

Transmitting AFSK RTTY signals is much simpler than FSK signals. It is usually only necessary to connect the tone keyer output to the transmitter audio input, adjust the tone level and transmit. Again, however, the duty-cycle rating of the transmitter should be considered. In particular, most VHF-FM transmitters are designed for intermittent duty and may NOT permit extended RTTY transmissions without reducing the transmitter power.

4.13.3 Adjustment of the ST-6000 Tone Keyer

The tone frequencies generated by the tone keyer are all derived from crystal oscillators and therefore do not require adjustment. The audio output voltage can be adjusted with an internal potentiometer, as explained in section 4.12. When the tones are used with SSB transmitter, the tone level should be adjusted to produce the desired transmitter output power. When used with an AFSK transmitter system, the tone level should be adjusted to produce the desired modulation percentage (AM transmitter) or deviation (FM transmitter). In all cases, avoid over-driving the transmitter audio stages as this will cause distortion and transmission of spurious signals.

NOTE: DO NOT ATTEMPT TO TRANSMIT UNLESS THE PRINT SWITCH IS IN LOCAL POSITION OR THE KOS IS ACTIVATED AS DISCUSSED IN SECTION 4.8 AND 4.9 ABOVE.

5. ST-6000 CIRCUIT DESCRIPTION

Most of the circuitry of the ST-6000 is constructed on two circuit boards, the input board and the control board. In addition, a rear panel circuit board provides connection and RF by-passing for the rear panel connectors and a flexible circuit board connects the LED indicators to the control board. The power supply and amplifiers for the optional oscilloscope are constructed on two boards that are attached to the scope shield. A complete block diagram of the ST-6000 is shown in Figure 5.1.

5.1 ST-6000 Analog Processing Circuits - Input Circuit Board

The audio tones from the receiver are processed by a number of analog circuits on the input board. These circuits are: input AGC circuit, active bandpass filter, limiter amplifier, active discriminator filters, discriminator detectors, and active low-pass filter. The appropriate schematic diagram is referenced for each discussion.

5.1.1 Input AGC Circuit (Figure 5.3)

The audio input to the ST-6000 is first coupled through a 500 to 500 Ohm transformer to the input AGC amplifier. The transformer allows connection of the ST-6000 to either a balanced or unbalanced audio source and provides DC isolation of the input. A MFC 6040 electronic attenuator IC and a MC 1458 dual operational amplifier are used in a pre-filter AGC circuit. This circuit is particularly intended to prevent overload of the following active filters by very strong input signals. However, it also provides some gain as well as smoothing of level variations in weaker signals.

5.1.2 Input Bandpass Filters (Figure 5.4)

A total of three multiple-feedback second-order active bandpass filters are used in the ST-6000, each using $\frac{1}{2}$ of a MC 1458 operational amplifier. The first filter, using IC3a is tuned close to the mark frequency (2125 Hz for "high-tones", 1275 Hz for "low-tones"). The second filter is tuned close to the space frequency. The center frequency of this filter is adjusted with the shift switch to correspond to the space frequency of the selected shift. A third filter, the "post-filter" is tuned midway between the mark and space frequencies. The gain, bandwidth, and center frequency of the post filter are adjusted with the shift switch and alignment controls to give an over-all flat bandpass filter response for the three stages while maintaining steep skirt selectivity. It is NOT recommended that field adjustment of these filters be attempted. Stable, high-quality components are used in this section to assure trouble-free operation. If problems do occur in this section, it is highly recommended that the unit be returned to the factory for repair and realignment.

5.1.3 Limiter Amplifier (Figure 5.5)

After passing through the input bandpass filter, the signal is next processed by the limiter amplifier stage, IC11. The CA 3130 integrated circuit used in the limiter is capable of gains approaching 120 dB and has, in addition, a wide bandwidth and high input impedance. When this IC is used essentially "open-loop" (no feed-back resistor), it becomes a very effective audio limiter stage. The very large input signal dynamic range of the ST-6000 (greater than 80 dB) is due, in large part, to the performance of this stage. When the limiter switch is in the OFF position, the gain of the CA 3130 is reduced to allow it to act as a linear amplifier for "AM" operation of the demodulator.

5.1.4 Discriminator filters (Figure 5.6)

Separate mark and space discriminator filters are constructed of two high-Q active filters, one filter for each tone. These filters are specifically designed for broad band-width, linear phase, response to assure optimum signal recovery in the face of noise and to minimize phase distortion of the signal. The space filter center frequency and the bandwidth and gain of both mark and space filters are controlled by the shift switches and the alignment potentiometers. As in the input filter section, user adjustment of these filters is NOT recommended.

5.1.5 Discriminator Detectors (Figure 5.1)

The signals from the mark and space discriminator filters are detected in separate active detector circuits that use a MC 1458 (I13) integrated circuit. This circuit avoids the normal non-linearities and offset voltages of simple diodes and gives precision rectification of the AC signal over a wide dynamic range of input signal amplitudes. These circuits further reduce signal distortion when using the "FM" mode of reception (limiter ON). When combined with the input AGC circuit, they provide exceptional performance when using the "AM" mode (limiter OFF). The mark and space detectors are set-up to generate opposite polarity DC voltages which are then combined to produce the output data. When combined with the broad-bandwidth discriminator filters, a very linear, high-performance discriminator is formed. The polarity of the detected voltage is changed in both filters with the front panel SENSE switch.

5.1.6 Meter Amplifier and Detectors (Figure 5.7)

A portion of both the mark and space signals are also rectified with 1N270 germanium diodes, filtered, and amplified in a type 741 operational amplifier (I15). Since the polarity of the two diodes is the same, the output of the amplifier is positive for either mark or space signals, the amplitude being proportional to the match in frequency between the input tone and the discriminator mark or space filter. This is the "plus-plus" voltage previously discussed. This voltage is used to drive the tuning meter (except when the oscilloscope option is installed) and the autostart circuit.

5.1.7 Active Low-pass Filter (Figure 5.7)

Both sections of a MC 1458 IC are used in a three-pole active low-pass filter that follows the discriminator stage. The cut-off frequency of this filter is set to approximately 82 Hz to minimize noise on the signal while still allowing use of the ST-6000 at data rates up to 100 baud.

5.1.8 ATC Circuit (Figure 5.7)

When using the ST-6000 in the "AM" mode (limiter OFF), selective fading that reduces the amplitude of one of the tones but not the other can give rise to bias distortion. The ATC (Automatic Threshold Control) circuit acts as a "DC-restorer" circuit that rebias the input to the slicer to maintain voltage symmetry for mark and space pulses. This circuit is of most benefit in "AM" mode when a continuous stream of RTTY data is being received (such as a message transmitted by tape or from a semiconductor storage device). In "FM" mode (limiter ON), the ATC circuit may be useful for very deep selective fades but will, in general have little effect since both mark and space tones will undergo heavy limiting before the discriminator. Since the ATC level restoration depends upon RC time constants, chosen for a continuous data stream, it may cause distortion when slowly hand-typed data is received and should therefore be turned OFF when receiving this type of signal.

5.1.9 Tone Keyer (Figure 5.8)

The tone keyer section of the ST-6000 is very similar in design to that used in the HAL XTK-100 AFSK Oscillator. The circuit is made up of five basic sections: oscillators, keyer, divider, D/A converter, and lowpass filter. Five separate crystal-controlled oscillators are used in the tone keyer, one for each of the following outputs: mark (all shifts) 170 Hz space, 425 Hz space, 850 Hz space, and CW-ID (100 Hz below mark). The crystal frequencies are 2000 times the desired output frequency for "high-tones" (mark = 2125 Hz) and 3000 times the desired output for "low-tones" (mark = 1275 Hz). Crystals for special tone requirements are chosen to maintain a fundamental crystal frequency in the 3000 to 8000 kHz range and the 2000 or 3000 divider ratio adjusted accordingly. All five crystal oscillators operate continuously. The oscillators are ICs number 21 and 22.

Selection of which of the five oscillator outputs is passed along to the divider is made by the control signals applied to gates I21, I23 and I24. The control circuitry is arranged so that only one of the signals appears at pin 10 of I24 (TP12) at any one time. The gated signal is then divided by either 200 or 300 in circuits I20, I19, and I18. The jumpers labeled "H" and "L" on the schematic determine whether the divider ratio is 200 (H) or 300 (L). The output of I18 is then divided by 10 again in the I17 ringcounter circuit. The ten outputs of I17 are combined in a resistor network to give the digital-to-analog (D/A) conversion. The D/A resistor network is chosen to give a ten-step approximation to the desired sine-wave output. One-half of integrated circuit I16 serves as a single-pole lowpass filter to further suppress any harmonics of the output signal. The second half of I16 is an adjustable gain output amplifier, capable of output signal levels between 0 and -32 dBm into a 500 Ohm load. As on the ST-6000 input circuit, a 500 Ohm isolation transformer is used on the tone keyer output to permit driving a 500 Ohm balanced load and to give DC isolation. The only user adjustment in the tone keyer section is the output level control. The space frequencies of the tone keyer are automatically changed with the ST-6000 shift switch to permit true transceive operation. Also, the SENSE (NORM-REV) switch on the ST-6000 also reverses the mark and space tones of the tone keyer.

5.2 ST-6000 Control Circuit Board

All of the previous circuits described are located on the input (or analog) circuit board. The conditioned data output of this section is now used to drive the essentially digital sections of the ST-6000, the slicer, DTH circuit, antispace, autostart and output drivers and interfaces. With the exception of the tone keyer section, all of the digital control, interfacing and main power supply circuits are located on the control circuit board. These circuits are discussed in the following sections. As before, the appropriate schematic diagram is referenced for each discussion.

5.2.1 Slicer and DTH Circuits (Figure 5.9)

The analog data output from the ATC circuit (or lowpass filter if ATC is OFF) drives a high-gain limiting amplifier to produce fast rise-time keying pulses for mark and space data conditions. As discussed previously in section 4.5, RTTY signal timing distortion can be generated in high-power RTTY communications circuits by multiple path propagation between the transmitter and receiver. The most serious effect this multi-path interference has on the received signal is to introduce a time uncertainty when the mark-to-space (or vice-versa) transition occurs. Since the ST-6000 is basically a hard-limited, "FM" type of demodulator, this is fairly easily compensated for by introducing hysteresis in the slicer stage, thus requiring a "firm" transition in the data before the slicer output is permitted to change states. The DTH (Decision Threshold Hysteresis) switch makes this modification with DTH ON.

5.2.2 Antispace Circuit (Figure 5.9)

If a signal at the space frequency is held for a long period of time, the teleprinter will "run-open", making an annoying, louder than normal noise. To prevent this problem, sections of integrated circuits 2 and 3 are connected in a timer circuit that senses the length of the space signal and places the post-autostart data signal in a mark-hold condition whenever the space exceeds 250 ms. This section of the control circuitry is always active for the post-autostart data output.

5.2.3 Pre-autostart data output (Figure 5.9)

A section of integrated circuit I2 is used to buffer and invert the output of the slicer stage and provide a CMOS-compatible data output that is NOT controlled by either the antispace or autostart circuits. This data-output is available on the AUXILIARY rear panel connector (J3, pin 3) for use in those systems where the control is not desired or where user designed control circuits are to be used.

5.2.4 Autostart Circuit (Figure 5.9)

The "plus-plus" voltage from the meter amplifier on the input circuit board is used to drive the autostart threshold detector, integrated circuit I1. As explained previously, the "plus-plus" voltage is proportional to the frequency match between the input tones and the discriminator filter frequencies. It is only maximum and non-varying when the two tones (mark and space) match the filters. The offset bias applied to I1 is set to produce a rapid positive voltage transition at I1 output (pin 7) whenever the "plus-plus" voltage exceeds the of f set bias voltage. In practice, this adjustment should be set so that I1 does not trigger on noise pulses but does trigger whenever a valid RTTY signal is received. This is an adjustment that the user may wish to set to his own preference. If the threshold pot is set too close to the noise, the autostart will activate readily on noise and interference; if set too high, the autostart may not trigger at all, even on good RTTY signals.

The output of I1 drives an inverting amplifier and time delay circuit that determines the autostart response time. The turn-on time of the autostart can be switch selected for either approximately 1.5 or 3.5 seconds (AUTOSTART, SLOW-FAST switch). The run-off time after loss of signal is much shorter. The delayed control voltage is coupled through IC gates 13 (two sections) and 14 where it is combined with the antispace output and the standby control line to produce the post-autostart data output. The autostart may be defeated with the front panel AUTOSTART, ON-OFF switch.

The autostart output (as well as the standby line) also drives the motor power control circuit, two sections of I4 plus a MPS6518 relay driver transistor. This circuit turns on the motor relay, applying power to the MOTOR receptacle when the autostart senses a valid RTTY signal. A time delay circuit keeps the motor power on until approximately 20 seconds after the autostart senses loss-of-signal. At this time, power to the MOTOR receptacle is turned off and remains so until another valid signal is sensed by the autostart or until the standby line is activated. The motor power is always on when the standby line is in standby condition (LOCAL position of the PRINT switch). The motor circuit is NOT controlled by the antispace circuit.

5.2.5 Standby Circuit (Figure 5.9)

The third control of the post-autostart data line is the standby circuit. This can be activated by three sources. First, the front panel PRINT (LINE - LOCAL) switch provides manual control. When the switch is in LINE position, the post-autostart data line is controlled by the detected signal, pro-

viding the autostart has activated. When in LOCAL position, the post-autostart data line is locked in mark condition and the motor is held on for "local loop" types of operation. This same control line can be controlled externally through the Remote Standby connection on the AUXILIARY connector (J3, pin 2). When this line is at +12 Volts, the post-autostart data line can be driven by the detected signal. When the line is grounded, the post-autostart data output is held in mark-hold. The third control of the standby circuit is by the KOS circuit. Whenever the KOS circuit is in transmit mode, the post-autostart output is locked in mark condition to provide local loop operation (in half-duplex operation) and to prevent re-triggering of the loop that might be caused by reception and detection of the transmitted signal.

5.2.6 Post-autostart Data Output (Figure 5.9)

The outputs of the antispace circuit, the autostart circuit, and the standby control line are combined in gate I4 and buffered in I2 to give a post-autostart data output of the ST-6000. This data signal is connected to pin 10 of the AUXILIARY rear panel connector (J3). Either this signal or the pre-autostart data signal can be used to drive the loop stages, the RS-232-/MIL-188 interfaces, or external equipment, as selected by jumpers on the AUXILIARY connector. The standard jumper plug furnished with the ST-6000 connects the post-autostart data signal to drive the loop keyer stages. Both the pre- and post-autostart data signals are CMOS logic signals with mark = 0 Volts and space = +12 Volts. Part of the versatility of the ST-6000 lies in the fact that these signals are available for external connection and can be jumpered to suit individual requirements.

5.2.7 Loop Keyer Stages (Figure 5.10)

The ST-6000 has two high-voltage loop keyer stages that can be connected to drive up to two different loop circuits. Both keyer stages are driven by the output of gate I10. Two inputs to this gate are provided on the AUXILIARY connector; Transmit Loop Drive (pin 13) and Receive Loop Drive (pin 6). Either input can be used to drive the keyer stages with the reservation that the Receive Loop Drive input is also used to drive a circuit to differentiate between keyboard interruptions of the loop and loop keying due to received data. Both inputs require CMOS-compatible levels (mark = 0, space = +12 V.). The standard jumper plug for the AUXILIARY connector connects the post-autostart data output (pin 10) to the Receive Loop Drive input (pin 5).

Both keyer stages use a type 2N5655 keying transistor, rated at 100 mA (mark) or +200 volts (space) maximum. Both have series RC transient protection across the collector circuits. One of these stages is called the "Main Keyer" stage and has its collector connected to pin 4 of the Loop 1 & 2 connector (J8), where it is called "Loop 1". The emitter of this "Main Keyer" stage has a series resistor to ground to sense the loop current through the transistor. This signal is amplified by a MPS3394 to produce a CMOS-compatible output signal that has the same data as Loop 1, whether it originates from a received signal or from external devices in the loop (such as from a keyboard, tape transmitter, or other device). This output signal is called "Loop Sense" and is connected to pin 11 of the AUXILIARY connector (J3). The standard jumper plug for the AUXILIARY connector uses this signal to drive the tone keyer input (pin 15) and the RS-232/MIL-188 data output interfaces. This Loop Sense signal is also combined with the Receive Loop Drive signal in gate 1 to produce the Loop Keyboard output signal (pin 1, J3). The Loop Keyboard output signal is again CMOS-compatible and represents ONLY the data generated in the loop EXTERNAL to the ST-6000. This signal is normally jumpered in the standard AUXILIARY jumper plug to drive the KOS circuit (jumper from pin 1 to pin 5 of J3).

The other keyer, called the "Auxiliary Keyer" stage, simply switches to ground on mark and does not have a current sensing circuit. The collector of this keyer transistor is connected to pin 2 of the Loop 1 & 2 connector (J8), where it is referred to as "Loop 2". This second loop keyer can be used

to switch external and separate loop circuits from Loop 1 or can be used in any application requiring a switch-to-ground on mark type of control.

5.2.8 RS-232/MIL-188 Interfaces (Figure 5.11)

The ST-6000 also includes interface circuits to allow interconnection to devices requiring EITHER EIA-RS-232C or MIL-STD-188C data signal levels. Input data from either RS-232 sources (pin 4 of J5, the RS-232/MIL-188 connector) or MIL-188 sources (pin 6 of J5) are combined with a Keyboard data in signal (pin 5 of J3, pin 3 of J6 or pin 3 of J8) to produce the CMOS-Compatible Local Data Output signal (pin 14 or J3). This Local Data Output signal can then be used to drive the tone keyer or other devices. This signal also drives the KOS circuit for automatic control of transmit-receive functions of the station.

The Keyboard Data In signal can originate from the previously discussed Loop Sense signal (standard AUXILIARY plug jumper), separate keyboard contacts or switching transistor that switches to ground, or other loop-isolated data generation devices. Because of the various ways in which this input can be used, parallel connections are provided on the AUXILIARY connector (J3, pin 5), the KOS connector (J6, pin 3) and the Loop 1 & 2 connector (J8, pin 3).

Output signals compatible with RS-232 (pin 1 of J5) and MIL-188 (pin 3 of J5) devices are generated in the two sections of integrated circuit I9, a type 5558 dual operational amplifier. The amplifiers are driven by the signal called "Interface Drive" (pin 4 of J3, the AUXILIARY connector). Thus, the interfaces can be driven from any CMOS-compatible data source within or external to the ST-6000. The standard AUXILIARY jumper plug connects the Loop Sense output signal to the Interface Drive input so that all Loop 1 data is available with both RS-232 or MIL-188 compatible outputs. As suggested in section 3, these outputs can also be used to drive diode FSK circuits or devices such as the HAL RVD-1002 or RVD-1005 Visual Display Units ("Voltage" or "EIA" inputs).

5.2.9 KOS Circuit (Figure 5.12)

The KOS (Keyboard Operated Switch) circuit of the ST-6000 allows automatic control of the transmit-receive functions of a radio station or can be used for other control functions. The KOS circuit senses the data from the Local Data signal output and the CW-ID hand key. Recall from the above discussion that the Local Data output signal only reflects data to be transmitted (from the keyboard, RS-232 input, or MIL-188 input). Therefore, ONLY transmit data is allowed to trigger the KOS circuit. The KOS circuit will switch to transmit mode IF a spacing condition of 5 ms or more is sensed from the Local Data signal or IF the CW-ID key is closed. Thus, the transmitter will be activated by the KOS if any key on the keyboard is depressed (KOS triggered by the start pulse) or if the CW-ID key is used. The KOS will return to receive mode under three conditions; if the Local Data remains in mark condition for more than 1 to 10 seconds (user adjustable), or 1 second after completion of the CW-ID operation. Therefore, the station reverts to receive condition if the teleprinter break key is used ("fast-break") if typing is stopped for a preset length of time (1 to 10 seconds of mark) or upon completion of the CW-ID sequence. Adjustment of the mark time delay is discussed in section 4.9. Notice that, when the KOS is in transmit mode, the post-autostart output data line is held in mark condition and the power to the MOTOR receptacle is turned on.

5.3 Front Panel Indicators

The operation of the front panel indicators (see Table 4.2) can now be explained in terms of the control circuitry of the ST-6000. The MARK, SPACE, and AUTO indicators are shown in Figure 5.9. The MARK indicator is driven directly from the output of the slicer stage. Thus, it ALWAYS indicates

the state of the received data (mark = on), regardless of the condition of the autostart or KOS circuits. This lamp also indicates the status of the pre-autostart data output.

Similarly, the SPACE lamp is used to indicate the status of the post-autostart data (space = on) and will therefore be controlled by the autostart and KOS circuits.

The AUTO LED indicates the status of the autostart circuit and is on whenever the autostart control line will allow passage of the received signal to the post-autostart data output. Notice that, if the autostart is turned OFF with the front panel switch, this AUTO lamp will remain on.

The LOOP LED (see Figure 5.10) is driven directly from the Loop Sense circuit and therefore indicates the status of the "Main" keyer transistor or Loop 1. This lamp is on for mark condition and off for space condition.

The status of the KOS circuit is indicated by the KOS LED. This lamp is on whenever the KOS circuit is in the transmit condition (see Figure 5.12).

The POWER lamp (Figure 5.13) senses the presence of BOTH the +12 and -12 Volt outputs of the main power supply. Thus, a failure of either voltage will reduce the intensity of the lamp and a total power failure will extinguish the lamp.

5.4 Power Supply (Figure 5.13)

The main Power supply rectifiers, filters and regulators are constructed on the control circuit board. The power transformer, loop resistor, and fuses are mounted directly on the cabinet.

The +12 and -12 voltages required by the ST-6000 are derived from a full-wave bridge rectifier. The +12 Volt supply is regulated with a type 7812 integrated circuit regulator, the -12 Volt by a type 7912 IC. As noted previously, the POWER LED indicates presence of BOTH voltages.

The +175 Volt, 60 mA loop voltage is derived from a full-wave rectifier. The LOOP fuse and current limiting resistor are mounted on the cabinet. The plus lead of the loop supply is routed to the rear-panel connector board, through the fuse, the limiting resistor, to the Loop 3 connector (J7, pin 1). Pin 3 of the Loop 3 connector is then connected via the circuit board to pin 1 of the Loop 1 and 2 connector (J8), where it is called "Loop High (+)". Therefore, a jumper or TTY machine MUST be connected between pins 1 and 3 of the Loop 3 connector to use either the "Main" (Loop 1) or "Auxiliary" (Loop 2) keyer stages.

5.5 Oscilloscope (Figure 5.14)

The tuning oscilloscope section in the ST-6000 includes the 1" cathode-ray-tube, its front-panel controls, vertical and horizontal deflection amplifiers high voltage power supply and a power transformer with high-voltage winding for the CRT. The high voltage supply is contained on one circuit board that mounts directly to the tube shield. The supply is arranged to generate both +480 Volts and -240 Volts. The deflection amplifiers and bias networks for the CRT are constructed on a second circuit board, mounted on the other side of the tube shield. The two deflection amplifiers are identical and have sufficient voltage gain to permit more than full screen deflection with the 2 Volt p-p signals available from the discriminator filters. Gain controls are provided for both horizontal and vertical amplifiers to permit user adjustment of the screen deflection, if desired. The gain control potentiometers are located on the board to the right of the CRT, looking back from the front panel. The control closest to the front panel is for vertical gain and the other control is for horizontal gain adjustment. A third potentiometer on this board is the ASTIG adjustment. This control can

be used in conjunction with the FOCUS and INTENSITY front panel controls to provide a sharp, well defined trace. This control has been factory adjusted and should not require readjustment unless the CRT itself is replaced. The front panel controls are self-explanatory and may be adjusted to the user's preference.

5.6 Cabinet Wiring

The ST-6000 is constructed in semi-modular form with most of the circuitry on the two large circuit boards, the input and control boards. The six LED indicators are mounted on a flexible circuit board which is attached directly to the switches on the control board. All of the rear panel connectors (with exception of the MOTOR and power line connectors) directly connect to a rear panel "mother" board that provides all RF bypassing and interconnection points to other connectors and circuit boards of the demodulator. Connections between the circuit boards and to cabinet-mounted components are made with either 16-conductor ribbon cables and plugs or plastic multi-conductor connectors similar to those used on the rear panel. All subassemblies are designed to permit quick removal for testing or replacement without unsoldering connections. Figure 5.14 shows the cable listings for each interconnect cable used in the ST-6000.

5.7 User Servicing

As discussed in this section and in section 4, there are a number of internal adjustments that the user may wish to trim to his requirements. Be careful to adjust ONLY these specific controls. Adjustment of other interior controls, particularly those in the active filter circuits is NOT RECOMMENDED. These adjustments should not change with time. If problems with these circuits are encountered, it is best to have the factory or authorized service representative test and service the complete unit. The user can check for presence of the indicated power supply voltages, if desired, but it is preferable to have all repairs made by the factory. If you should have to return the unit to the factory for service be sure to:

1. Write us in advance (or call) and get a return authorization.
2. Pack the unit CAREFULLY with ADEQUATE soft packing material to prevent shipping damage.
3. INCLUDE IN THE BOX WITH THE EQUIPMENT a list describing the failure mode(s) encountered.
4. Ship the unit (via UPS, preferred) to

HAL Communication Corp.
1201 W. Kenyon Rd.
Urbana, IL 61801
Attention: Service Department

ST-6000 Operating and Trouble-shooting Guide

General Notes on Receiving:

- 1) The signal type should match the printing equipment being used. Normal signals are standard Baudot or ASCII code (no greater than 110 baud).
- 2) HAL video printing equipment will only copy asynchronous data.
- 3) Normal/Reverse switch should be set to Normal and transceiver on Lower Sideband for most Amateur Radio RTTY.
- 4) The receiver passband should be sufficient to pass both mark and space tones, or attenuation of the higher tone may result.
- 5) In the presence of selective fading, use the ATC only if the sending rate is relatively fast. Otherwise, turn ATC off.
- 6) Use DTH only with high signal levels.
- 7) If you intend to run RS-232 or MIL-188 signals out of the ST-6000 to drive a printer, be sure to refer to sections 3 and 4 of the manual!
- 8) Cables are extremely important. Check all cables and pin connections carefully before operating the unit. This should include the auxiliary jumper plug (J3) on the back of the 6000 to insure that it is properly seated and all pins are making contact.

RCV

Does the 6000 receive off the air? ↓ No	→ Yes	Go to XMIT
Is power on? ↓ Yes	→ No	Check AC fuse, power cord, power line voltage
Is the tuning indicator working) ↓ Yes	→ No	Check audio input cables, proper shift selected, Limiter on
Is the Auto light on?	→ No	Is signal valid and being properly tuned, has the ST-6000 been on long enough for autostart to activate, check SLOW-FAST position, Limiter on check and adjust auto threshold potentiometer (internal)
Are Mark and Space lights both flashing? ↓ Yes	→ No	Print switch in line mode, KOS not active, check REMOTE STANDBY (J3-2) line - should be high, check loop 3 jumper, loop fuse, check series loop (J8) circuit, <u>ungrounded</u> loop, loop polarity observed when necessary? Check all cables, auxiliary jumper plug (J3), ribbon cables inside unit
Are you now getting print? ↓ Yes	→	Retrace RCV section if no success, more information needed (if using RS-232/MIL-188, see special instructions)

Now check other shifts and speeds.

General Notes on Transmitting:

- 1) DO NOT overdrive the transmitter if you are using the microphone input. If you notice that the ALC circuit of your transmitter becomes active, you are overdriving your transmitter
- 2) If you use a speech processor for voice transmissions, be sure you turn it off or disconnect it during RTTY transmission.
- 3) Reduce the power output of your transmitter while transmitting RTTY. RTTY is 100 % duty cycle and failure to reduce power could cause damage to your transmitter.
- 4) Make sure that the passband of your transmitter is of sufficient width to pass both the Mark and Space tones you are using.

THERE ARE THREE WAYS TO SET THE ST-6000 FOR TRANSMITTING:

- 1) KOS activated
- 2) Print switch in LOCAL position
- 3) REMOTE STANDBY line grounded

XMIT

Is the 6000 producing any output tones? ↓ Yes	→ No	TONE ENABLE (J3-12) should be low, tone level set?, cable to transmitter OK, shift switch selected
Is it making Mark and Space transition? ↓ Yes	→ No	Check continuity: Loop sense hooked to XTK DATA IN (J3 pins 11, 15), signal on J3-15 toggle with loop (mark to space, etc.)? CW-ID on? (pins J8-6 or J5-2)
Is the station transmitting: ↓ Yes	→ No	Retrace XMIT section, if no success more information needed.
Check other shifts, if desired.		

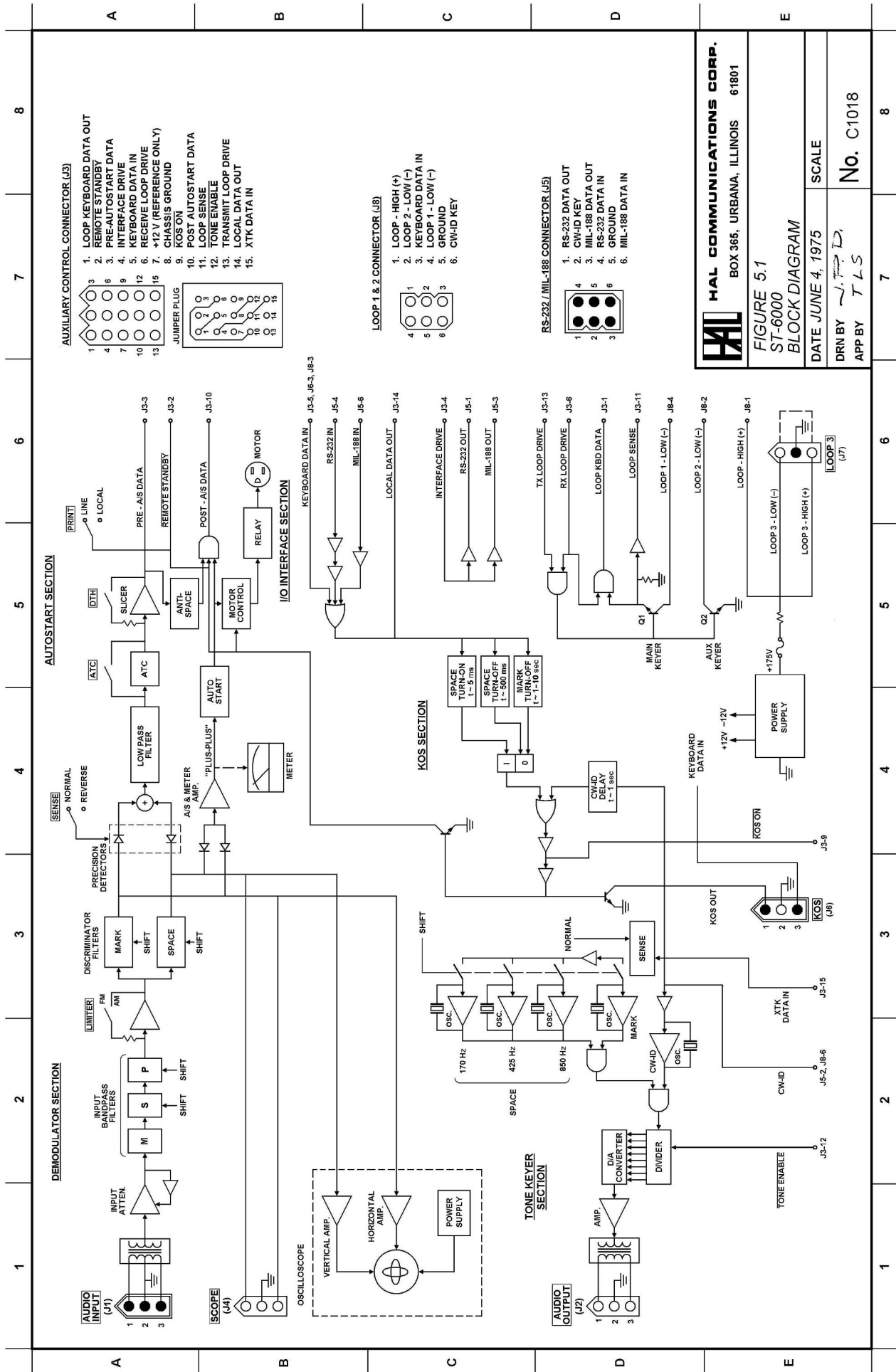

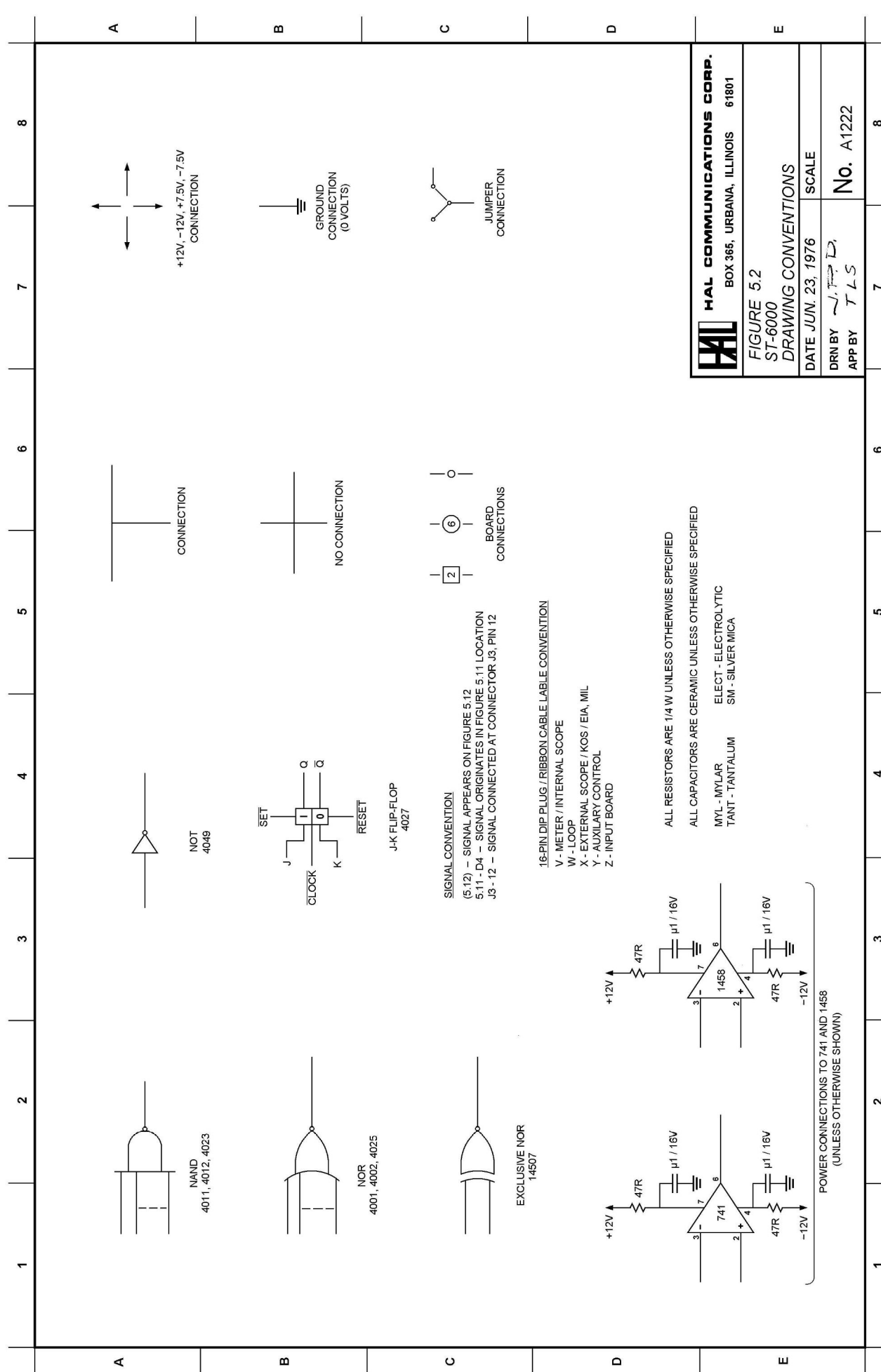

HAL COMMUNICATIONS CORP. BOX 365, URBANA, ILLINOIS 61801	
FIGURE 5.2 ST-6000 DRAWING CONVENTIONS	
DATE JUN. 23, 1976	SCALE
DRN BY <i>J. P. D.</i>	No. A1222
APP BY <i>T. L. S.</i>	

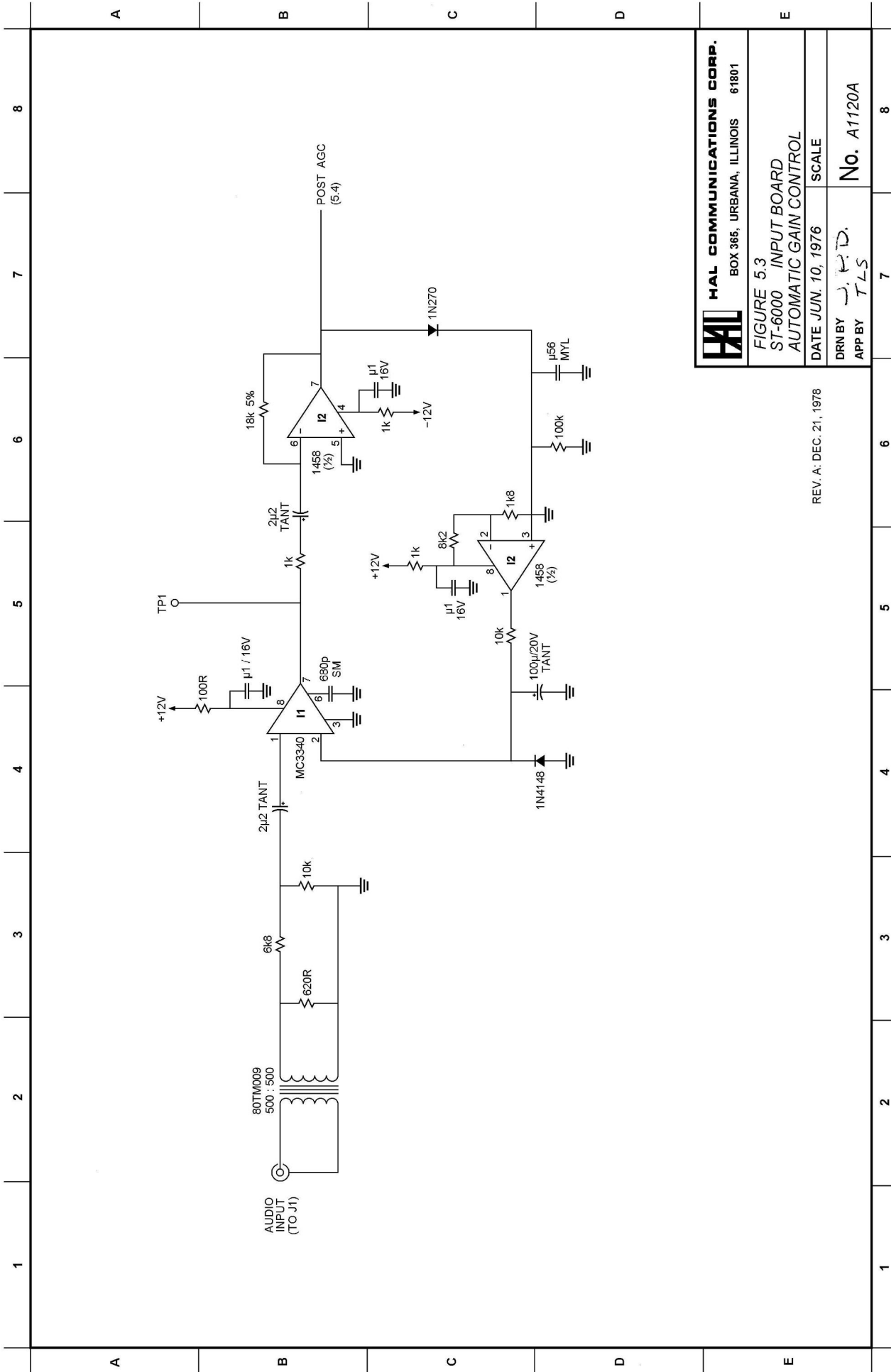

HAL COMMUNICATIONS CORP.
 BOX 385, URBANA, ILLINOIS 61801

FIGURE 5.3
 ST-6000 INPUT BOARD
 AUTOMATIC GAIN CONTROL

DATE JUN. 10, 1976 SCALE
 DRN BY J.R.D.
 APP BY T.L.S. No. A1120A

REV. A: DEC. 21, 1976

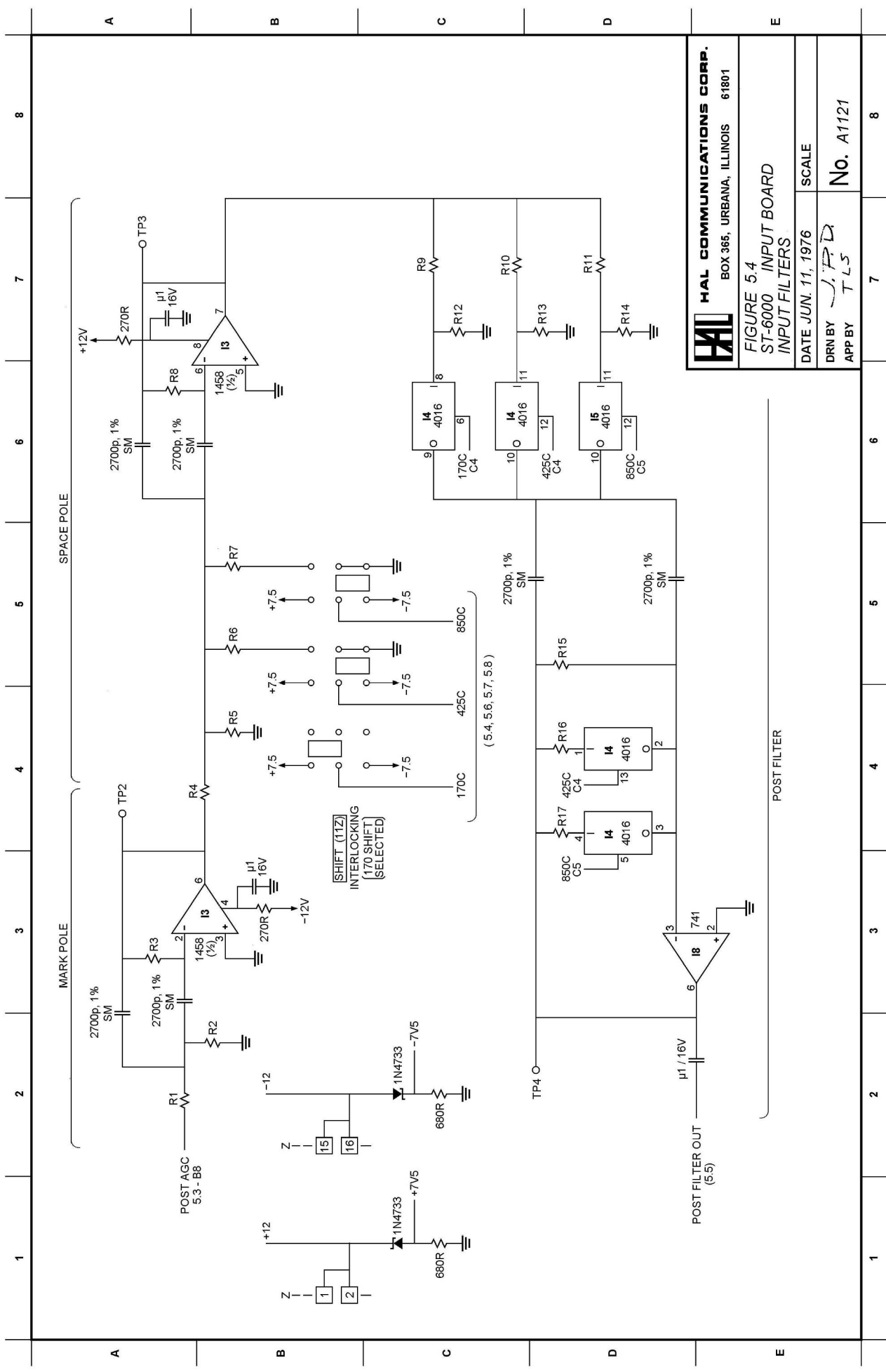

HAL COMMUNICATIONS CORP.
 BOX 365, URBANA, ILLINOIS 61801

FIGURE 5.4
 ST-6000 INPUT BOARD
 INPUT FILTERS

DATE JUN. 11, 1976
 SCALE
 DRN BY J.F.D.
 APP BY T.L.S.
 No. A1121

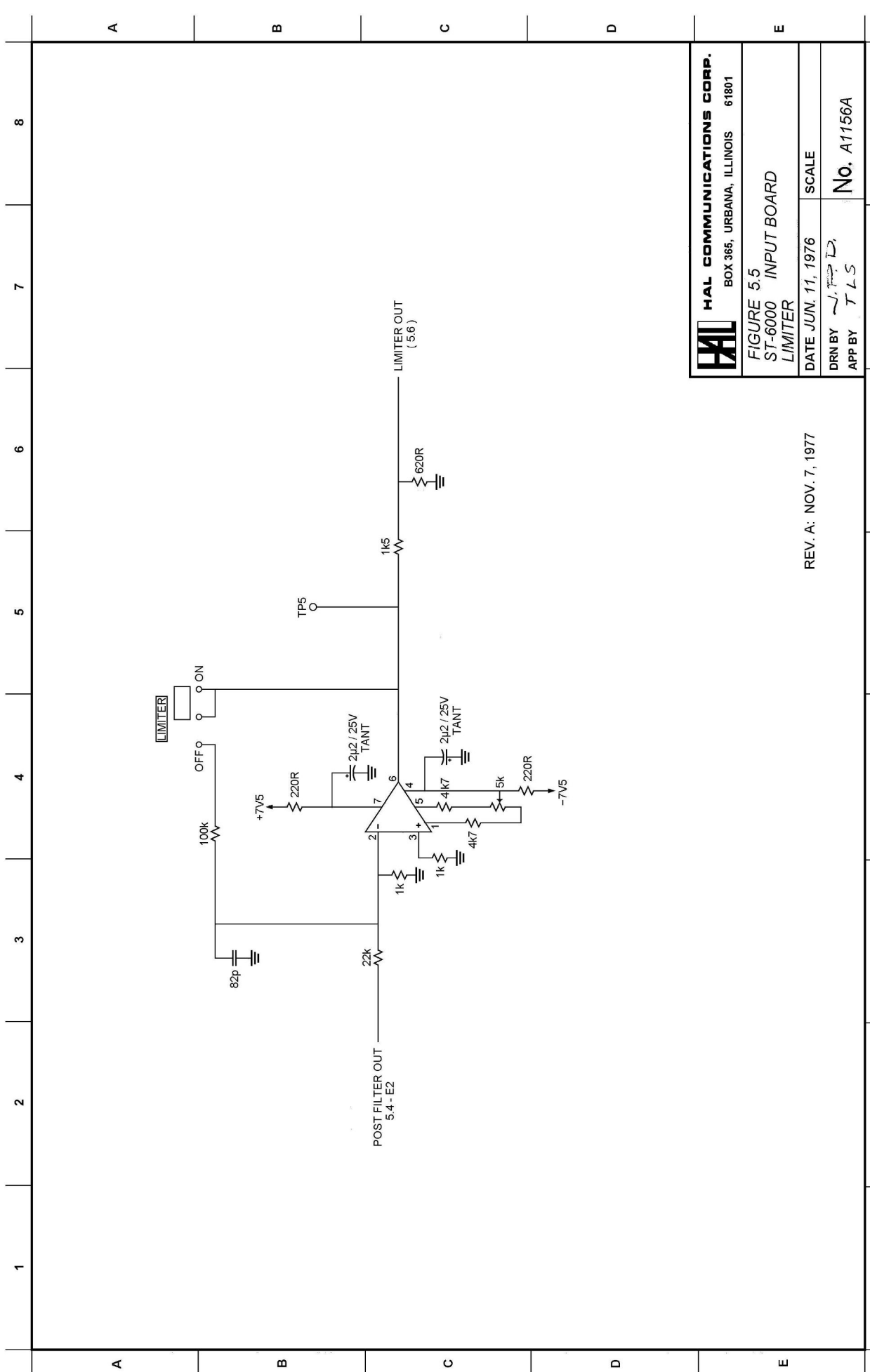

HAL HAL COMMUNICATIONS CORP.
 BOX 365, URBANA, ILLINOIS 61801

FIGURE 5.5
 ST-6000 INPUT BOARD
 LIMITER

DATE JUN. 11, 1976 SCALE
 DRN BY J. P. D.
 APP BY T L S No. A1156A

REV. A: NOV. 7, 1977

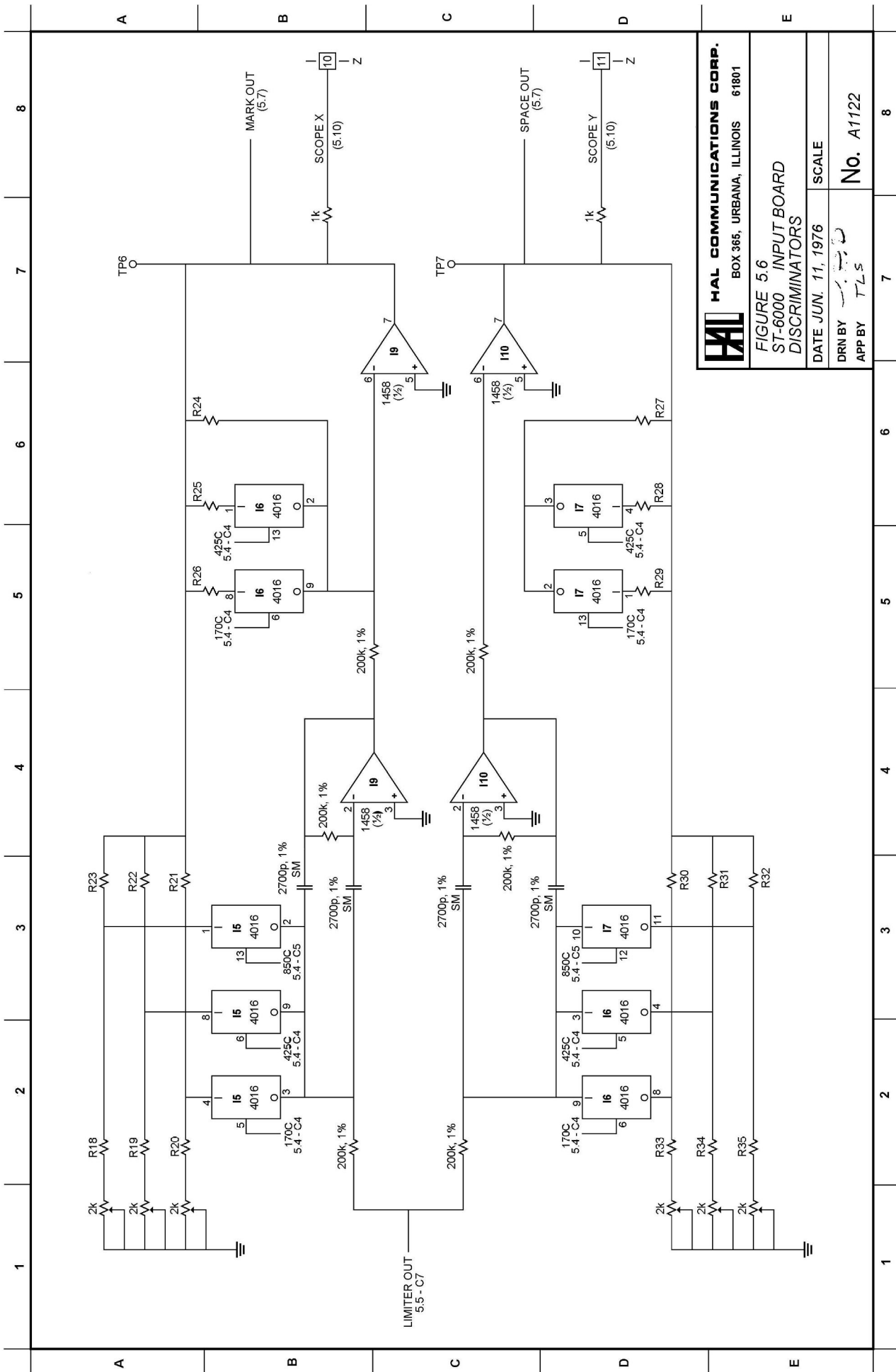

HAL COMMUNICATIONS CORP.
 BOX 366, URBANA, ILLINOIS 61801

FIGURE 5.6
 ST-6000 INPUT BOARD
 DISCRIMINATORS

DATE JUN. 11, 1976 SCALE
 DRN BY [Signature] APP BY TLS
 No. A1122

1 2 3 4 5 6 7 8

A B C D E

MARK OUT 5.6 - B8

SPACE OUT 5.6 - D8

METER (+) (5.10)

AUTOSTART INPUT (PLUS - PLUS) (5.9)

ANALOG DATA (5.9)

TP8

TP10

ATC

SENSE

REV -7.5 +7.5

NORM

REV +7.5 -7.5

TP9

TP10

ATC

SENSE

REV -7.5 +7.5

NORM

REV +7.5 -7.5

TP9

TP10

ATC

SENSE

REV -7.5 +7.5

NORM

REV +7.5 -7.5

TP9

TP10

ATC

SENSE

REV -7.5 +7.5

NORM

REV +7.5 -7.5

TP9

TP10

ATC

SENSE

REV -7.5 +7.5

NORM

REV +7.5 -7.5

TP9

TP10

ATC

SENSE

REV -7.5 +7.5

NORM

REV +7.5 -7.5

TP9

TP10

ATC

SENSE

REV -7.5 +7.5

NORM

REV +7.5 -7.5

TP9

TP10

ATC

SENSE

REV -7.5 +7.5

NORM

REV +7.5 -7.5

TP9

TP10

ATC

SENSE

REV -7.5 +7.5

NORM

REV +7.5 -7.5

TP9

TP10

ATC

SENSE

REV -7.5 +7.5

NORM

REV +7.5 -7.5

TP9

TP10

ATC

SENSE

REV -7.5 +7.5

NORM

REV +7.5 -7.5

TP9

TP10

ATC

SENSE

REV -7.5 +7.5

NORM

REV +7.5 -7.5

TP9

TP10

ATC

SENSE

REV -7.5 +7.5

NORM

REV +7.5 -7.5

TP9

TP10

ATC

SENSE

REV -7.5 +7.5

NORM

REV +7.5 -7.5

TP9

TP10

ATC

SENSE

REV -7.5 +7.5

NORM

REV +7.5 -7.5

TP9

TP10

ATC

SENSE

REV -7.5 +7.5

NORM

REV +7.5 -7.5

TP9

TP10

ATC

SENSE

REV -7.5 +7.5

NORM

REV +7.5 -7.5

TP9

TP10

ATC

SENSE

REV -7.5 +7.5

NORM

REV +7.5 -7.5

TP9

TP10

ATC

SENSE

REV -7.5 +7.5

NORM

REV +7.5 -7.5

TP9

TP10

ATC

SENSE

REV -7.5 +7.5

NORM

REV +7.5 -7.5

TP9

TP10

ATC

SENSE

REV -7.5 +7.5

NORM

REV +7.5 -7.5

TP9

TP10

ATC

SENSE

REV -7.5 +7.5

NORM

REV +7.5 -7.5

TP9

TP10

ATC

SENSE

REV -7.5 +7.5

NORM

REV +7.5 -7.5

TP9

TP10

ATC

SENSE

REV -7.5 +7.5

NORM

REV +7.5 -7.5

TP9

TP10

ATC

SENSE

REV -7.5 +7.5

NORM

REV +7.5 -7.5

TP9

TP10

ATC

SENSE

REV -7.5 +7.5

NORM

REV +7.5 -7.5

TP9

TP10

ATC

SENSE

REV -7.5 +7.5

NORM

REV +7.5 -7.5

TP9

TP10

ATC

SENSE

REV -7.5 +7.5

NORM

REV +7.5 -7.5

TP9

TP10

ATC

SENSE

REV -7.5 +7.5

NORM

REV +7.5 -7.5

TP9

TP10

ATC

SENSE

REV -7.5 +7.5

NORM

REV +7.5 -7.5

TP9

TP10

ATC

SENSE

REV -7.5 +7.5

NORM

REV +7.5 -7.5

TP9

TP10

ATC

SENSE

REV -7.5 +7.5

NORM

REV +7.5 -7.5

TP9

TP10

ATC

SENSE

REV -7.5 +7.5

NORM

REV +7.5 -7.5

TP9

TP10

ATC

SENSE

REV -7.5 +7.5

NORM

REV +7.5 -7.5

TP9

TP10

ATC

SENSE

REV -7.5 +7.5

NORM

REV +7.5 -7.5

TP9

TP10

ATC

SENSE

REV -7.5 +7.5

NORM

REV +7.5 -7.5

TP9

TP10

ATC

SENSE

REV -7.5 +7.5

NORM

REV +7.5 -7.5

TP9

TP10

ATC

SENSE

REV -7.5 +7.5

NORM

REV +7.5 -7.5

TP9

TP10

ATC

SENSE

REV -7.5 +7.5

NORM

REV +7.5 -7.5

TP9

TP10

ATC

SENSE

REV -7.5 +7.5

NORM

REV +7.5 -7.5

TP9

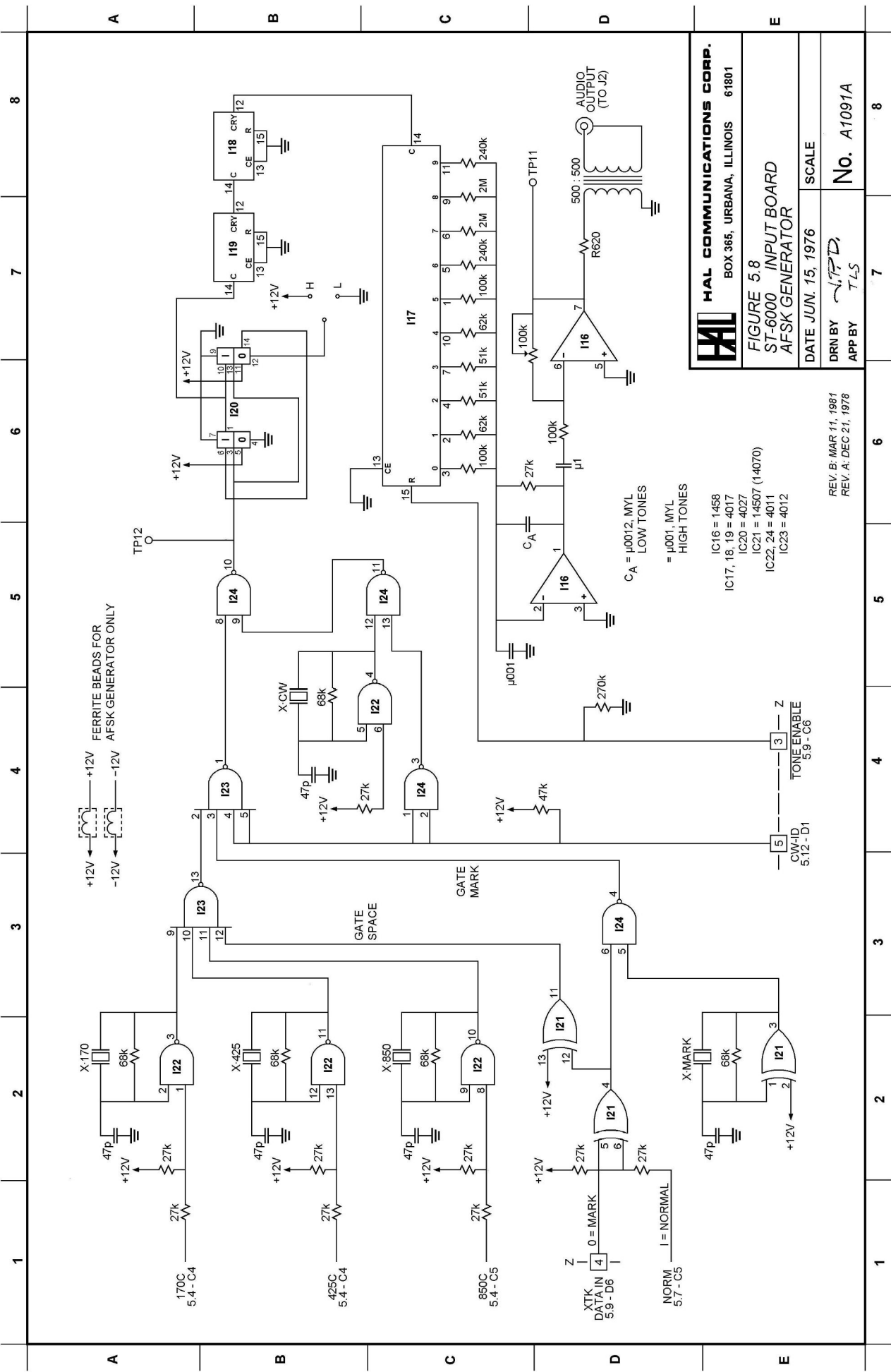

HAL HAL COMMUNICATIONS CORP.
 BOX 365, URBANA, ILLINOIS 61801

FIGURE 5.8
 ST-6000 INPUT BOARD
 AFSK GENERATOR

DATE JUN. 15, 1976 SCALE

DRN BY *TL* APP BY *TL*
 No. A1091A

IC16 = 1458
 IC17, 18, 19 = 4017
 IC20 = 4027
 IC21 = 14507 (14070)
 IC22, 24 = 4011
 IC23 = 4012

REV. B. MAR 11, 1981
 REV. A. DEC 21, 1978

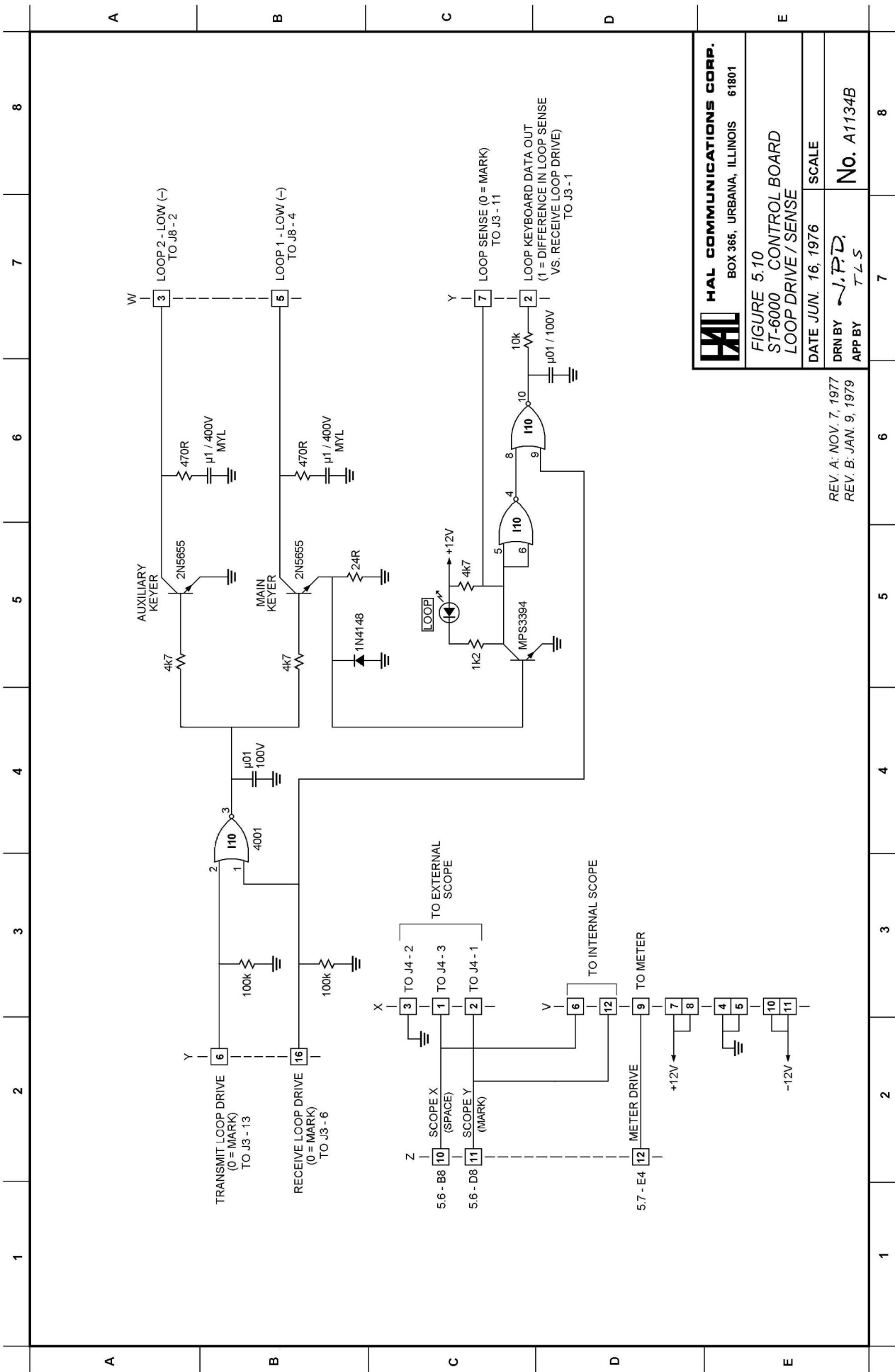

HAL COMMUNICATIONS CORP.
 BOX 366, URBANA, ILLINOIS 61801

FIGURE 5.10
 ST-6000 CONTROL BOARD
 LOOP DRIVE / SENSE

DATE JUN. 16, 1976 SCALE
 DRN BY J.P.D.
 APP BY T.L.S.

No. A1134B

REV. A: NOV. 7, 1977
 REV. B: JAN. 9, 1979

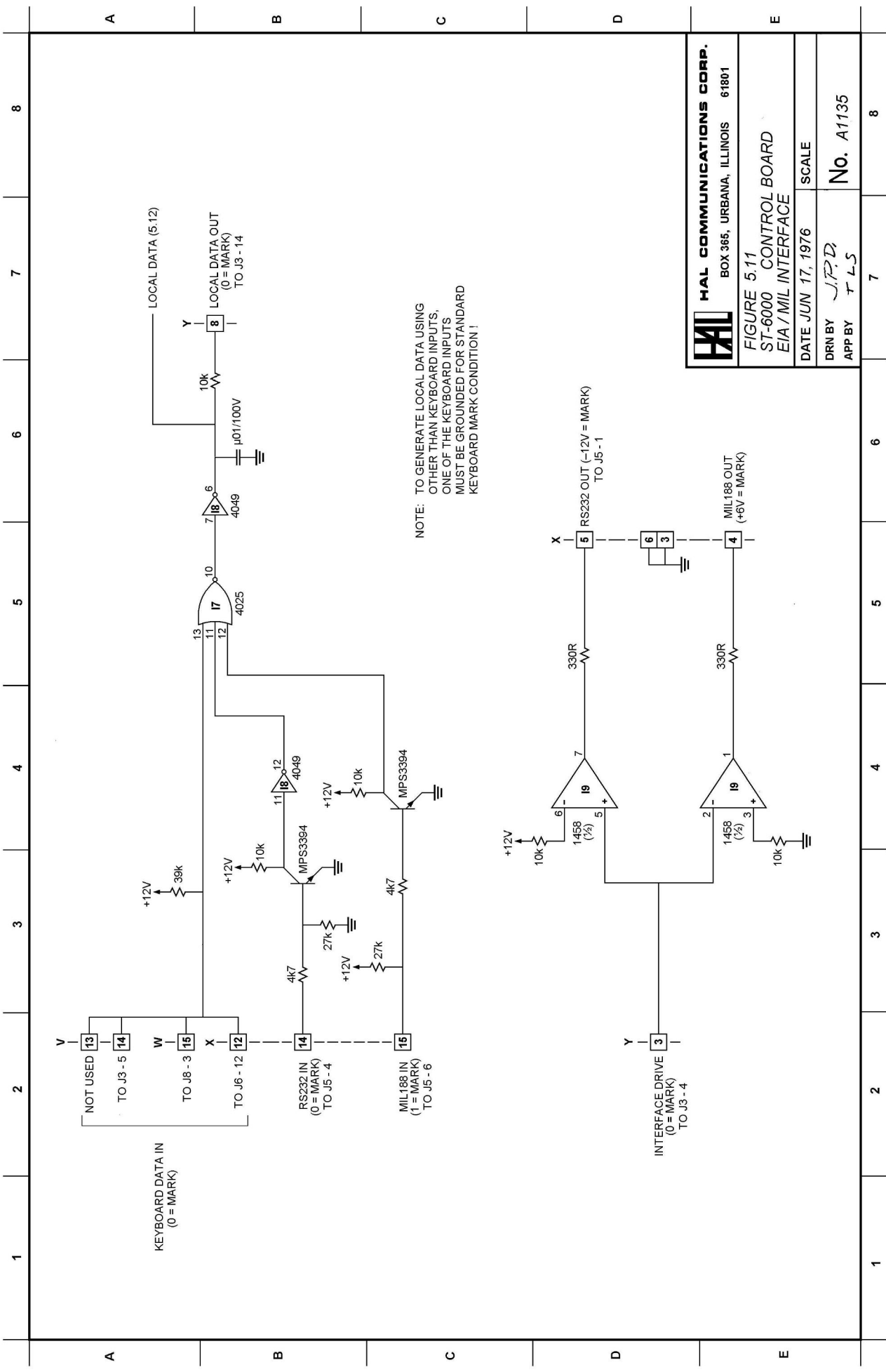

NOTE: TO GENERATE LOCAL DATA USING OTHER THAN KEYBOARD INPUTS, ONE OF THE KEYBOARD INPUTS MUST BE GROUNDED FOR STANDARD KEYBOARD MARK CONDITION!

HAL COMMUNICATIONS CORP.	
BOX 365, URBANA, ILLINOIS 61801	
FIGURE 5.11	
ST-6000 CONTROL BOARD	
E/A / MIL INTERFACE	
DATE JUN 17, 1976	SCALE
DRN BY J.P.D.	No. A1135
APP BY T.L.S.	

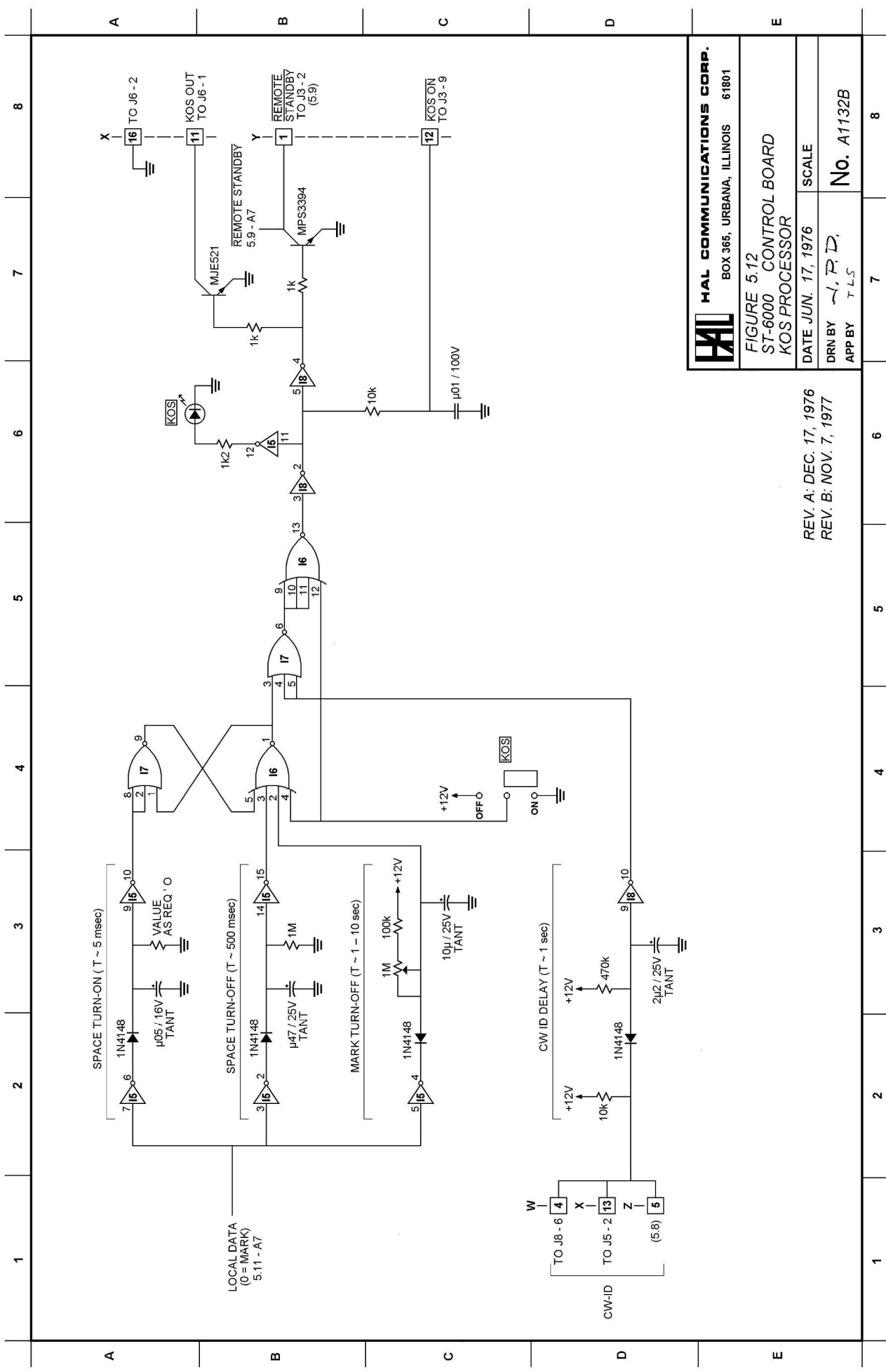

HAL COMMUNICATIONS CORP.
 BOX 365, URBANA, ILLINOIS 61801

FIGURE 5.12
 ST-6000 CONTROL BOARD
 KOS PROCESSOR

DATE JUN. 17, 1976 SCALE
 DRN BY *J.P.D.*
 APP BY *T.L.S.* No. A1132B

REV. A: DEC. 17, 1976
 REV. B: NOV. 7, 1977

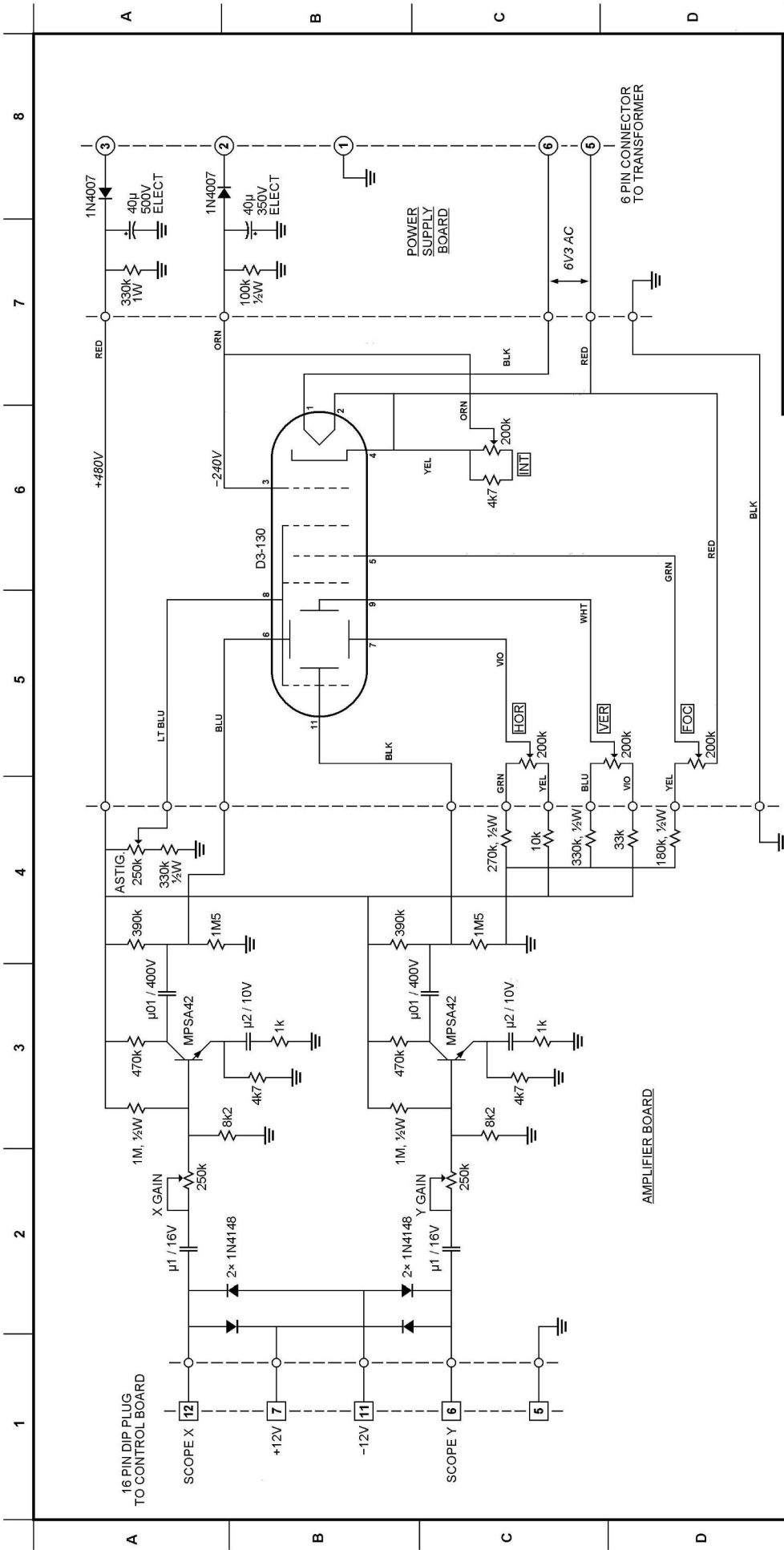

HAL HAL COMMUNICATIONS CORP.
 BOX 365, URBANA, ILLINOIS 61801

FIGURE 5.14
 ST-6000
 X-Y SCOPE INDICATOR

DATE JUN. 22, 1976 SCALE

DRN BY J.R.D.
 APP BY T.L.S. No. A1177

REV. A: JAN. 9, 1979

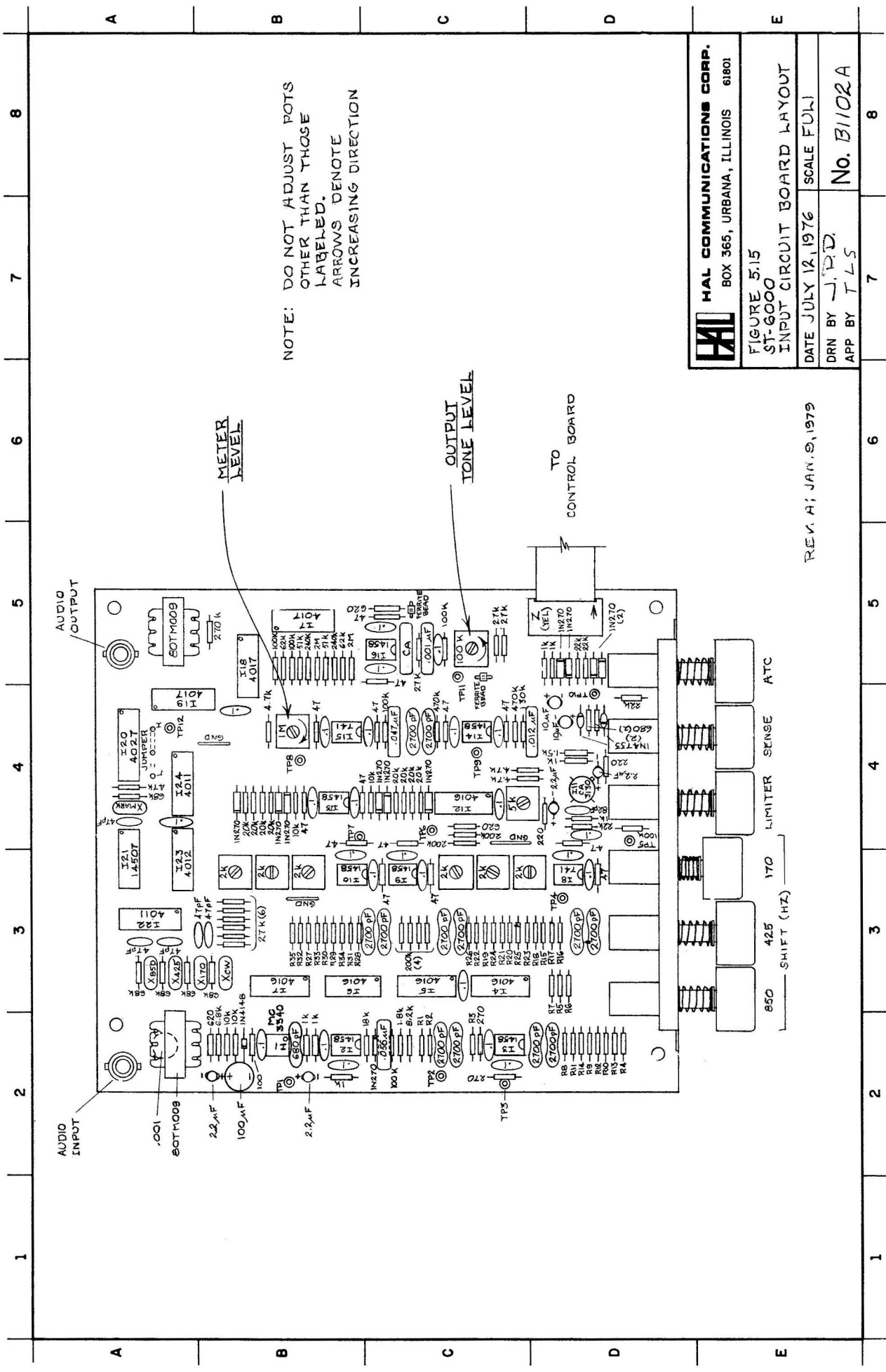

NOTE: DO NOT ADJUST POTS
OTHER THAN THOSE
LABELED.
ARROWS DENOTE
INCREASING DIRECTION

HAL HAL COMMUNICATIONS CORP.
BOX 365, URBANA, ILLINOIS 61801

FIGURE 5.15
ST-6000
INPUT CIRCUIT BOARD LAYOUT

DATE JULY 12, 1976 SCALE FULL

DRN BY J.P.D.

APP BY T.L.S. No. B1102A

REV A; JAN. 2, 1979

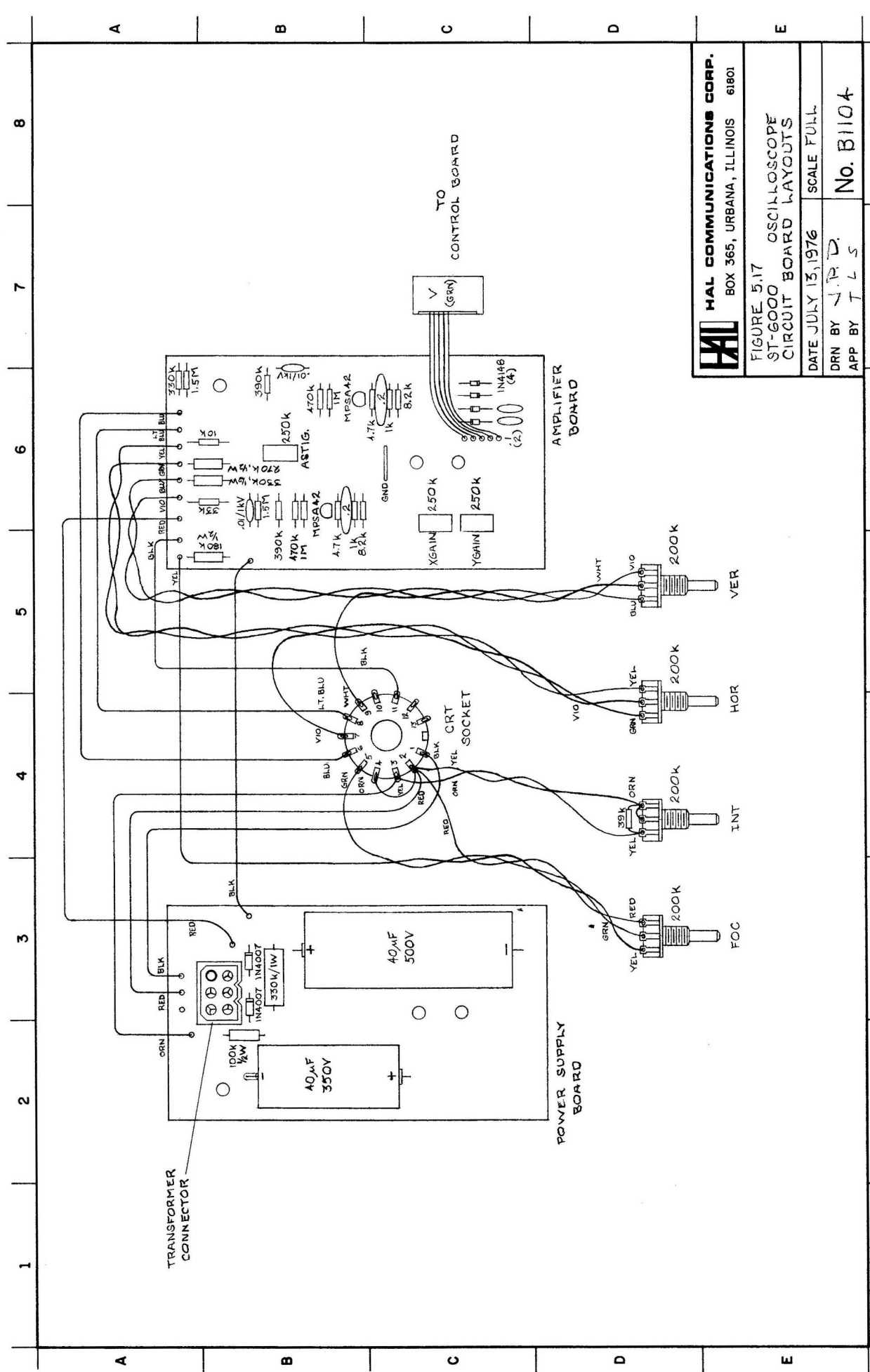

HAL HAL COMMUNICATIONS CORP.
 BOX 365, URBANA, ILLINOIS 61801

FIGURE 5.17 OSCILLOSCOPE
 ST-6000
 CIRCUIT BOARD LAYOUTS

DATE JULY 13, 1976 SCALE FULL

DRN BY *N.R.D.*
 APP BY T L S

No. B1104

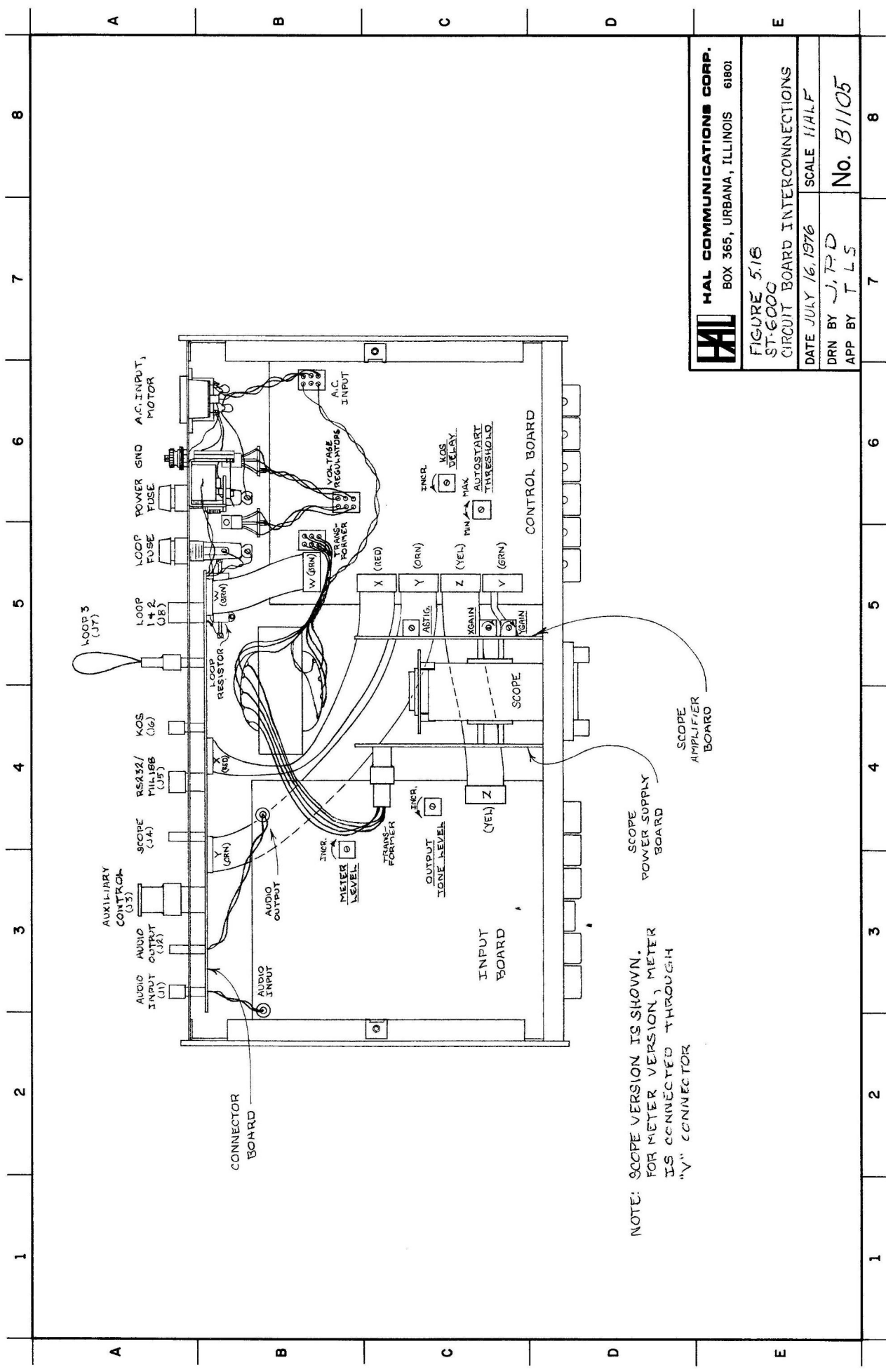

NOTE: SCOPE VERSION IS SHOWN.
 FOR METER VERSION, METER
 IS CONNECTED THROUGH
 "Y" CONNECTOR

 HAL COMMUNICATIONS CORP. BOX 365, URBANA, ILLINOIS 61801	
FIGURE 5.16 ST-6000 CIRCUIT BOARD INTERCONNECTIONS	
DATE	JULY 16, 1976
SCALE	HALF
DRN BY	J. T. P. D.
APP BY	T. L. S.
No. B1105	

APPENDIX A

1. RF-INDUCED PROBLEMS

HAL Communications equipment is designed to operate in close proximity to radio frequency transmitting and receiving equipment. Particular attention has been paid to the shielding of circuitry through the use of all-metal enclosures and good common grounds. However, under certain conditions in an RF-saturated environment, HAL equipment may be susceptible to RF-induced interference. This may manifest itself in any of a number of ways, such as partial or complete lack of response to operator commands, or erratic behavior of a video display.

The first thing that should be checked if RF problems are suspected is the ground system. The transmitter should be properly grounded for RF (in addition to electrical ground) and all other station equipment grounds should be connected to the transmitter chassis. The RF ground should consist of a short length of heavy copper wire or braid terminated at a good earth ground (ground rod or copper cold-water pipe). If a water-system ground is used, be sure that the pipes are 100 percent metal from the point of connection to the water mains – plastic plumbing will break the ground path. If the distance between your transmitter and ground rod or water-main ground is more than a quarter wavelength at the highest operating frequency, make the ground wire a half wavelength, or a multiple of a half wavelength long. If you plan to operate on 10 and 15 meters you may need to run a separate ground wire for each band if the distance requires the use of half-wavelength wires. For example, if the distance from the ground point exceeds about 8 to 10 feet, a 10-meter half-wave ground wire (16 feet long) and a 15-meter half-wave ground wire (22 to 23 feet long) would be used. Consult any of the amateur handbooks or antenna books for a more in-depth discussion of grounding techniques.

The best way to confirm that a problem is being caused by RF induction is to temporarily eliminate the source. This may be done in stages, starting with a partial reduction in exciter drive, and ending with transmitter shut-off. Since RF energy can be induced in the demodulator or video terminal circuitry through several different paths, connecting the transmitter to a dummy load may not eliminate all RF related problems, although this is an excellent first step in verifying RF problems.

Radiation of RF energy from linear amplifiers, antenna tuners, coaxial switches, monitor scopes, and interconnecting coax-cable jumpers is also possible. In fact, it is this type of radiation that is most likely to be coupled into nearby I/O and power cables going to HAL equipment. To locate the point or points of radiation, experiment with different cable arrangements to see if the RF-induced problem can be eliminated by reducing coupling between any of the HAL cables and nearby coaxial lines carrying RF power. Fig. 1A contains several cable arrangements, both bad and good, showing how to keep RF coupling to a minimum. The drawing in Fig. 1B shows the use of high-mu (950 or 2000) ferrite toroids or rods to choke the flow of RF on audio and control lines.

If cable rearrangement doesn't yield positive results, then begin eliminating pieces of equipment and sections of coaxial cable until the transmitter is connected directly into a shielded dummy load. As each piece of equipment is removed from the transmission line, check to see if the RF-related problems have diminished or disappeared. If the RF problem persists with the exciter connected directly to a dummy load reduce the drive level to see if that eliminates the problem.

If operation into a dummy load does not significantly reduce the RF-related problems, disconnect all I/O cables from the affected piece of HAL equipment. Test operation of the unit while it is connected only to AC power. At the same time, enable the transmitter so that it sends a CW signal into a dummy load. If RF problems are still present, then RF energy is probably being introduced to the HAL equipment circuitry through the power cord by means of the common AC power line.

This is usually indicative of poor AC-line filtering in the radio transmitter power supply section. Fig. 2A shows a common bypass-filter method used in many transmitters. The drawing in Fig. 2B depicts a brute-force AC-line filter that can be added to transmitters or other equipment to eliminate the flow of RF on power lines.

RF-induced problems that cannot be cured, or ones that appear not to be the fault of inadequate transmitter filtering should be referred to HAL factory Customer-service personnel. In cases where this is not feasible, or where station rearrangement is necessary to affect complete elimination of RF problems, the information in the following section may be of some help.

2. MINIMIZING RF-RELATED PROBLEMS THROUGH ANTENNA SELECTION

In addition to the liberal use of RF bypassing capacitors on station equipment, the use and deployment of certain antennas will offer reduced levels of RF in the radio room in many cases. Whenever possible, use resonant Yagi, quad, dipole or vertical antennas. Try to achieve a good impedance match at the antenna instead of relying on an antenna tuner. Random-length wire antennas and others that require tuning from the shack are more likely to create high levels of RF within the vicinity of the operating position.

The location of the transmitting antenna with respect to the radio room also has an effect on the RF energy that is coupled into interconnecting cables. Apartment dwellers may have the most difficulty achieving a good installation since many times an indoor antenna is the only type allowed. When this is the case, locate the antenna as far away from the operating position as possible. Where outdoor antennas are allowed, they should be placed as high as practicable. Not only will this provide optimum reception, but it will also reduce the level of RF in the shack – all other factors being constant. Excellent antenna installation information can be found in radio & electronics handbooks and antenna theory and construction booklets, as well as in articles published in electronics periodicals.

In most situations, coaxial cable feed line is preferred over open-wire, twin-lead or single-wire type feed systems as its self-shielding property reduces the chance of unwanted RF coupling.

RF energy may also be conducted back to the station by coupling of RF between the antenna and the outside shield braid of the coaxial cable feed. The use of a balun on a center-fed dipole fed with coaxial cable may also help reduce coupling, and therefore reduce interference. An RF choke constructed by winding five or six turns of coaxial cable in a coil approximately six inches in diameter may also help reduce the flow of RF currents on the outside of the coaxial-cable braid. If such a choke is used, it should be wrapped with electrical tape to hold the windings together, and be secured as close as possible to the feed point of the antenna.

Try to dress the coaxial cable feed lines so that they drop perpendicular to the antenna wire, and not parallel to the radiating portion of an element. In some cases, it may be necessary to run the coaxial cable straight to the ground and bury it for the run to the transmitter to reduce the coupling between the outside shield braid of the coaxial cable and the antenna. If there is a moderate SWR on the line, try adjusting the coaxial cable length so that a low impedance (high feed current) is presented to the transmitter. This may help reduce the level of RF in the vicinity of the transmitter.

POOR

WORSE

CORRECT

BEST

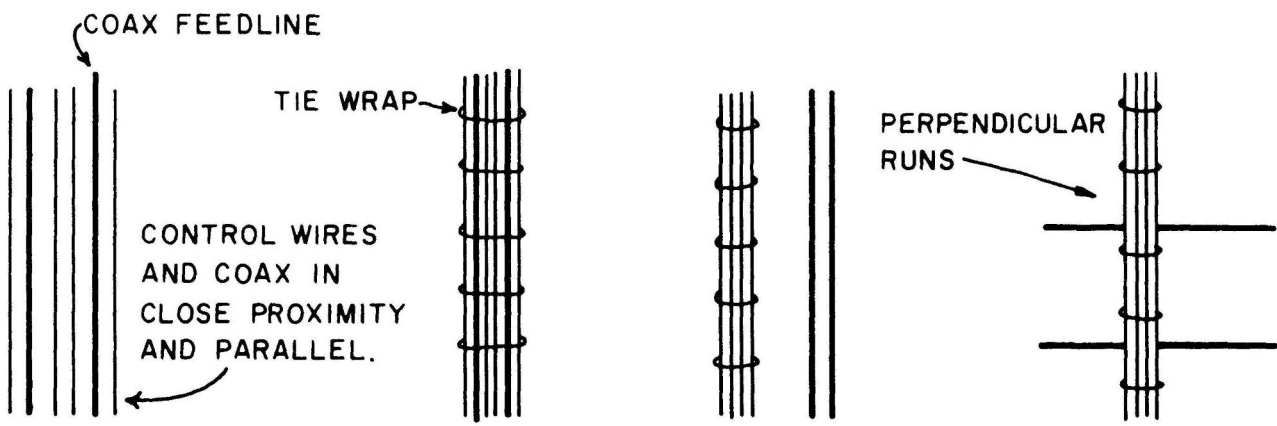

(A)

PLACE RF CHOKE CLOSE TO REAR PANEL OF EQUIPMENT

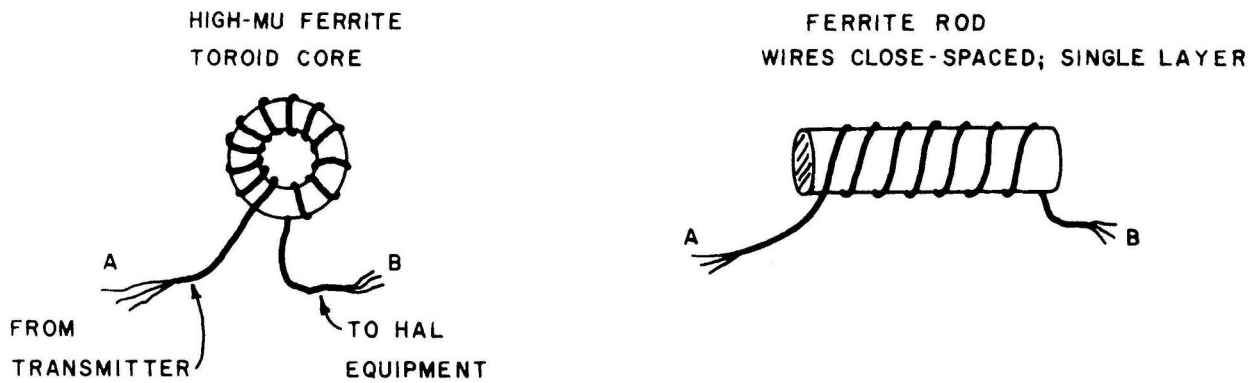

(B)

FIG. 1 -- (A) Cable arrangements, showing ways to reduce rf coupling.
(B) Use of high-mu ferrite toroids and rods to choke the flow of rf on audio and control lines.

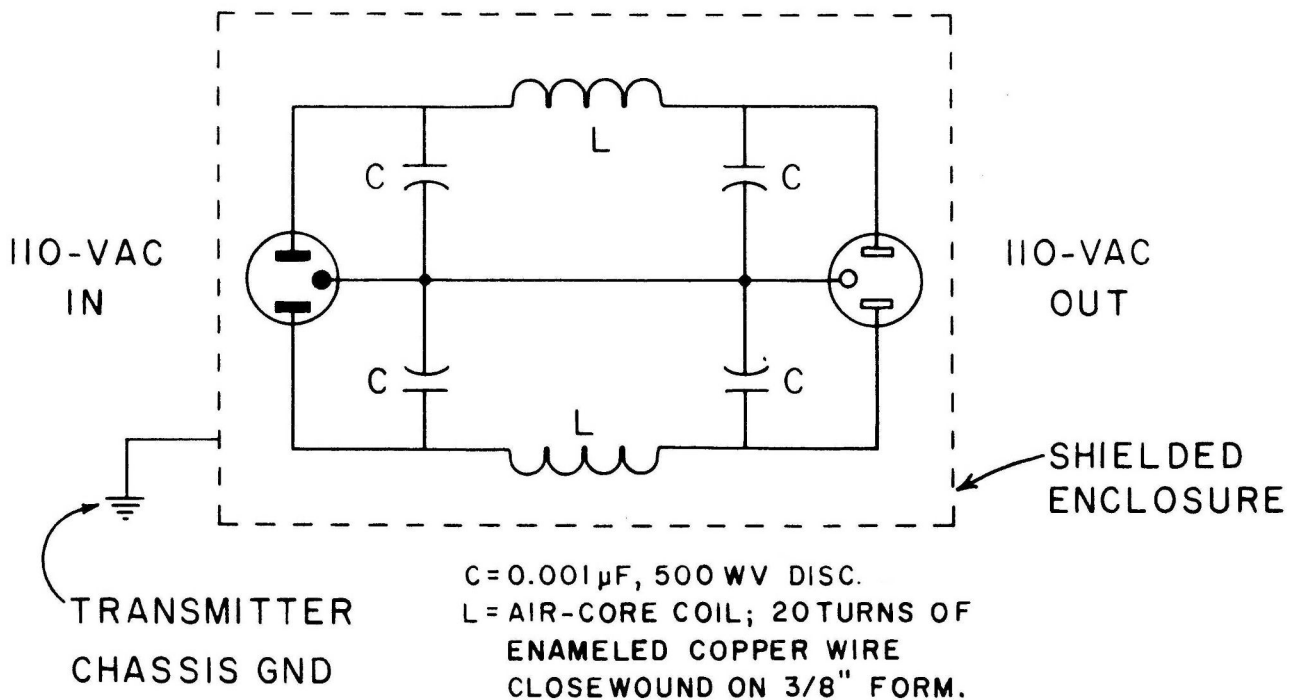
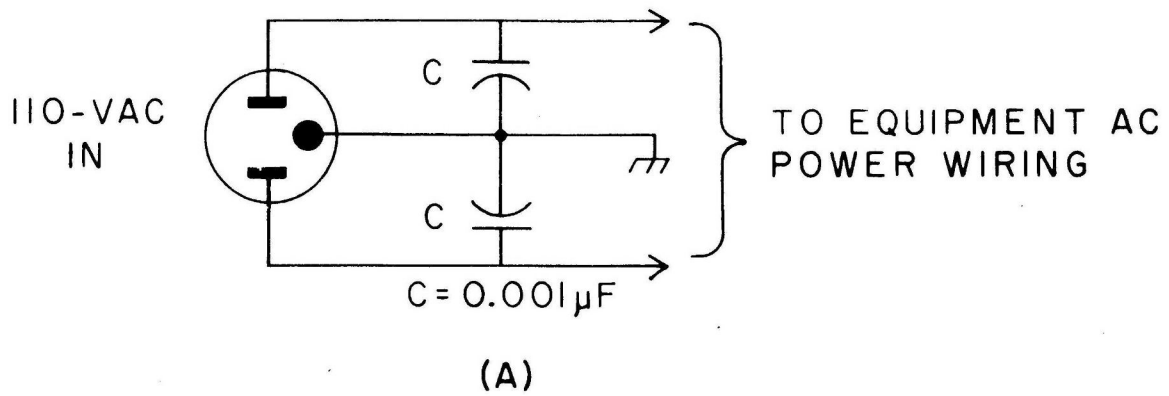

FIG. 2 -- (A) Simple rf-bypass method used in many transmitters.
(B) Brute-force ac-line filter that can be added to reduce or eliminate the flow of rf on the power line.