

TRXPTC, a modem for inside a radio

Preliminary technical description

SCS has developed a small modem card which is suitable to be implemented into general purpose HF radio transceivers. This card, the **TRXPTC** is capable of all operation modes which also our stand alone PACTOR modems are capable of. The TRXPTC is also capable of controlling the radio's frequency (TRX-control feature). Supported radios for TRX-control are ICOM, Kenwood, Yaesu, SGC, Rohde & Schwarz.

The TRXPTC consists of a **90 mm x 80 mm** sized, double side assembled, printed circuit board. With this small size it can easily fit into a HF radio.

The command set of this radio is similar to the PTC-IIusb, so the manual of the PTC-IIusb can be used as reference for the general operation. This manual can be found on our website.

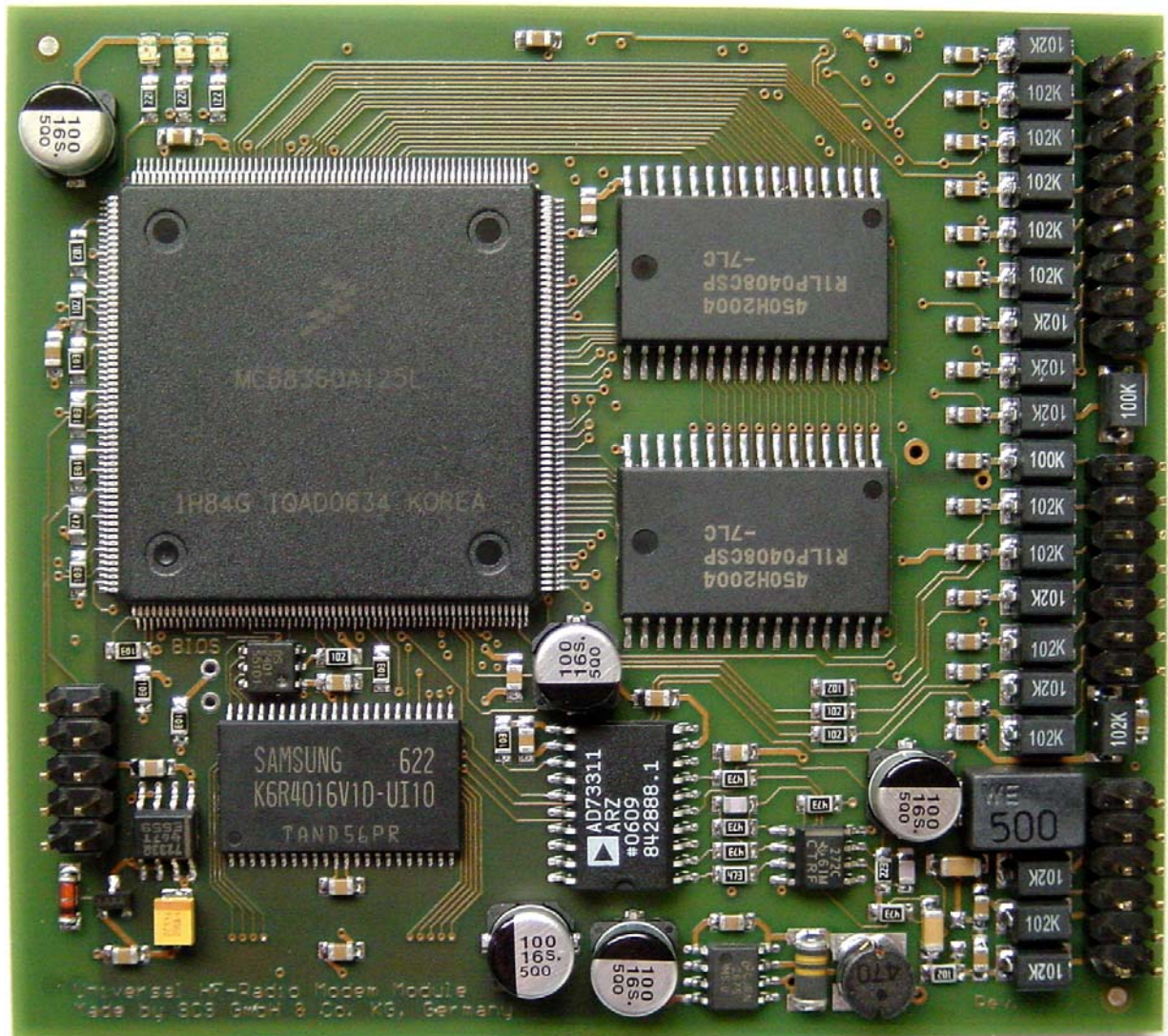

Top side view

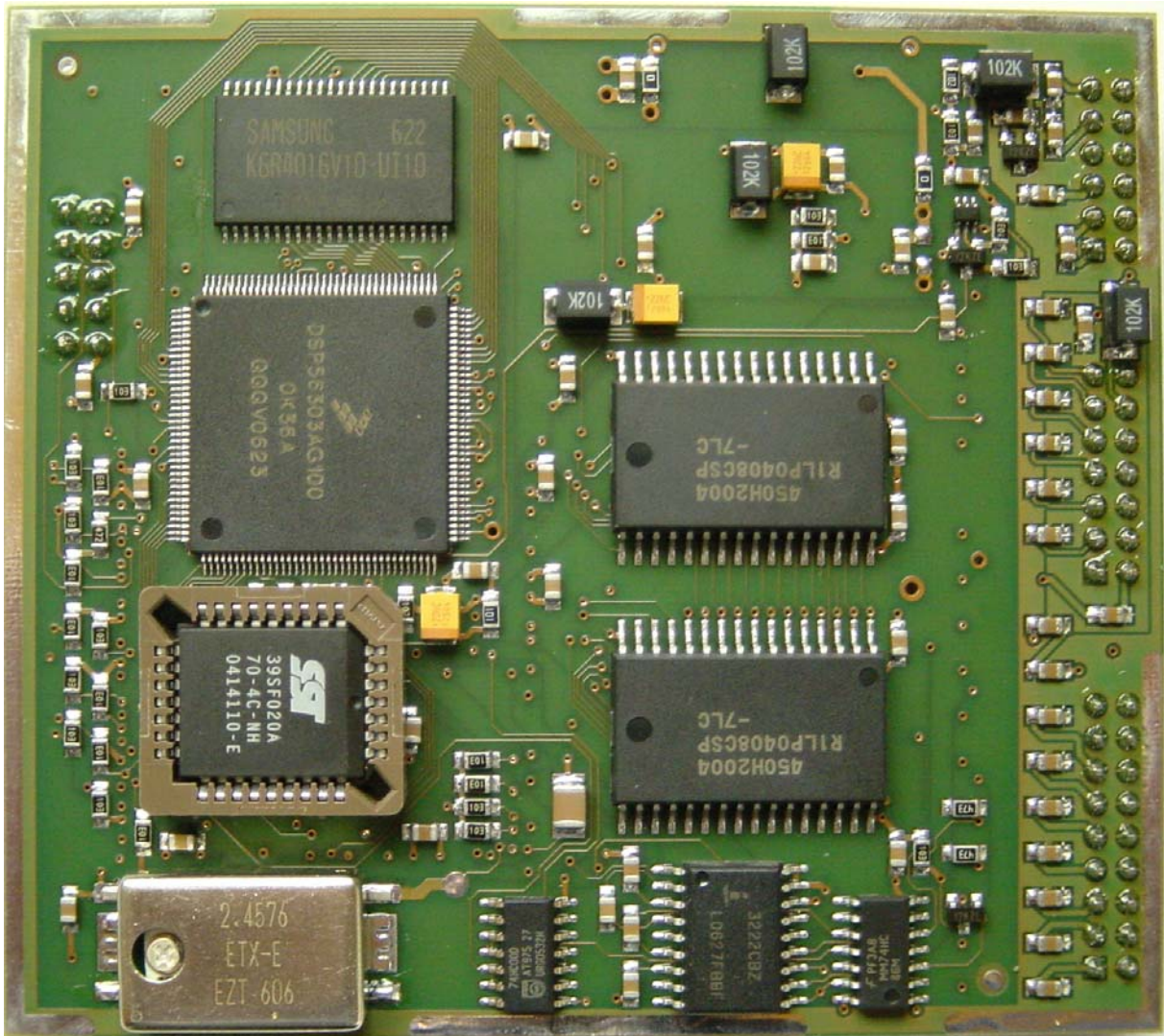

Bottom side view

Connectors:

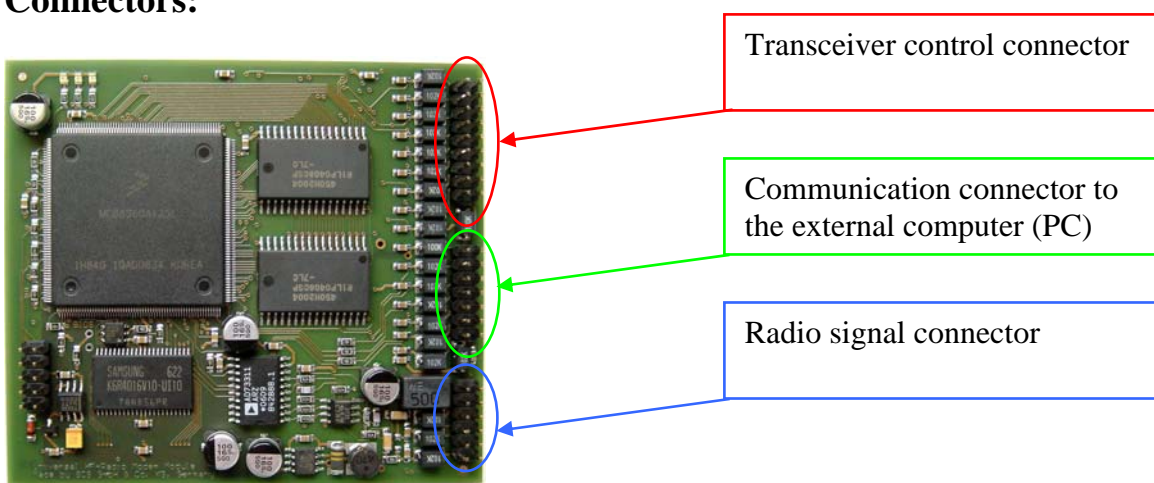

Transceiver Control Connector – Signals and pinning

RTS-TTL	1	■ ●	2	TGND
TXD-TTL	3	● ●	4	TGND
ICOM CI-V	5	● ●	6	TGND
RXD-TTL	7	● ●	8	TGND
CTS-TTL	9	● ●	10	TGND
RTS-V24	11	● ●	12	TGND
TxD-V24	13	● ●	14	TGND
CTS-V24	15	● ●	16	TGND
RXD-V24	17	● ●	18	TGND

The transceiver control signals are similar to our stand alone modems (PTC-IIpro/PTC-IIusb). The signals can be wired internally the radio to the required connection. For detailed information on the TRX-control features of **SCS** modems, please refer to the manuals of either the PTC-IIpro or PTC-IIusb, which are available for download on the **SCS** website.

Communication Connector – Signals and pinning

3.3V	1	■ ●	2	IGND
RXD	3	● ●	4	IGND
TXD	5	● ●	6	IGND
DSR	7	● ●	8	IGND
CTS	9	● ●	10	IGND
RTS	11	● ●	12	RI
DTR	13	● ●	14	CD

The communication connector provides a full featured serial port signaling, but in TTL levels and not V24. It's purpose is to exchange data with the PC that operates the modem. Currently a Bluetooth interface is available for that. The Bluetooth-transceiver (BT-TRX) is connected to this connector using a flat ribbon cable of the required length. The BT-TRX has to be mounted in a way at the rear side of the HF-radio, so that the antenna sticks out of the backpanel and has free radiation space. More about that below.

Instead of Bluetooth, also a V24 or USB interface could be connected as well. **SCS** will make this available on request. For the beginning the BT-interface has been favorized because it avoids any wired connection to the HF-radio where the modem is implemented into. This avoids susceptibility and interference.

Detailed information about the operation of **SCS** modems with Bluetooth can be found on the **SCS** website.

Radio Signal Connector – Signals and pinning

PWR-GND	1	■ ●	2	TGND
+ SUPPLY	3	● ●	4	TGND
GPS-IN	5	● ●	6	TGND
PTT	7	● ●	8	TGND
RX-AUDIO	9	● ●	10	TGND
TX-AUDIO	11	● ●	12	TGND

This connector carries the standard signals which are basically necessary to operate a HF modem. These are mainly received (RX) audio signal, transmit (TX) audio signal and PTT. Additionally, this connector has a GPS-in signal. Here any NMEA GPS device can be connected to (TTL and V24 compliant). Also, the supply power for the modem board is connected here.

Grounding and decoupling concept:

To avoid any interference between the modem board and the HF-transceiver electronics, all signals at all connectors are excessively filtered. With this, also separate grounds are distinguished. The modem's internal ground signal is named "GND". The transceiver's ground is named "TGND". The ground signal for the communication interface connector (in this case the ground for the Bluetooth-radio) is the "IGND". All grounds are decoupled by inductors. The power-supply ground "PWR-GND" is routed to the internal GND via a common mode filter which also routes the +SUPPLY.

Separating ground signals by inductors can be advantageous to prevent HF currents from flowing, but it can also be disadvantageous in some cases. Because of this, the integration of the modem board into a radio might require changes of the inductor values or replacing inductors just with wires. In the standard configuration, the ground filtering looks as follows:

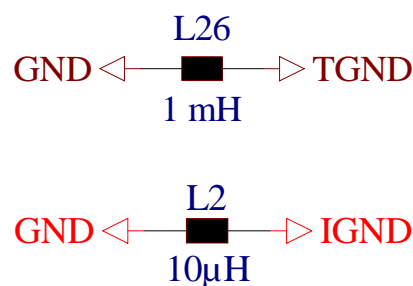

Signal Pin filtering:

The signal pin filtering generally looks as follows:

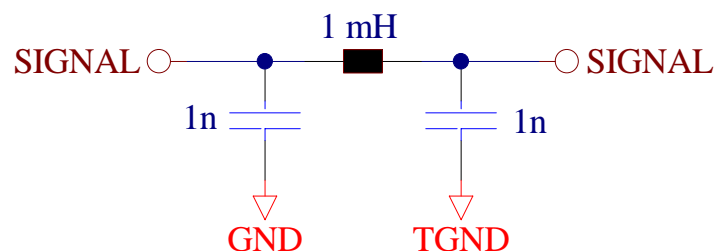

All signal pins are filtered by a PI-filter, whereby the internal capacitor goes to the modem ground “GND” and the external capacitor goes to the transceiver ground “TGND”. The low frequency signals are filtered with $L = 1 \text{ mH}$ and $C = 1 \text{ nF}$. Higher frequency signals are filtered with $L = 100 \text{ }\mu\text{H}$ and $C = 470 \text{ pF}$, this are mainly the RXD/TXD signals of the communication connector. Values may vary on application and later experience.

The “TGND” signal surrounds the whole pcb on the bottom side. Plain areas without solder coating are given to enable the PCB to be soldered into a shielding enclosure, whereby the enclosure then connects to “TGND”.

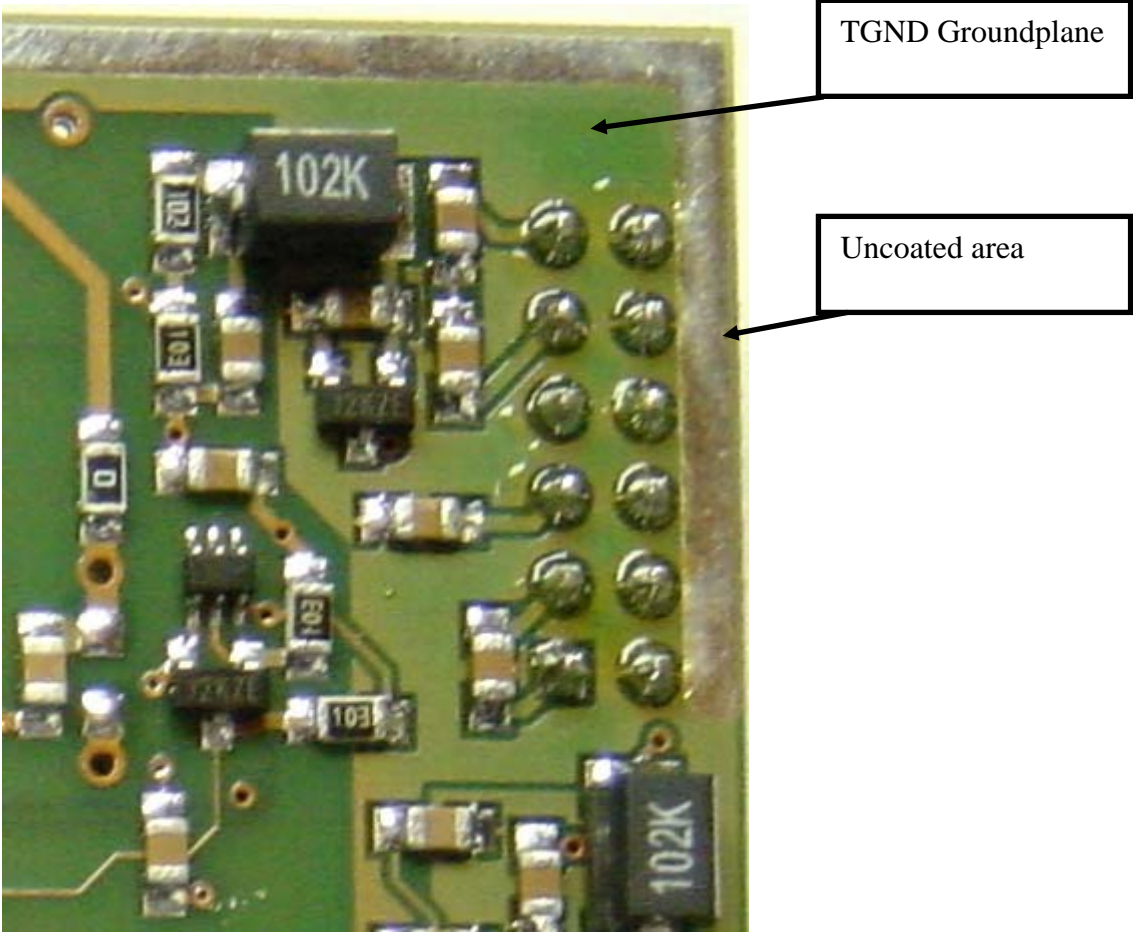

PTT circuit:

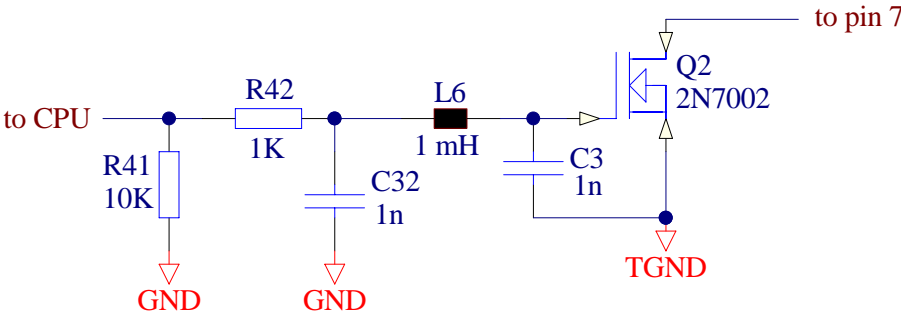

To provide low impedance PTT switching, the filter is in the gate of the switching MOSFET.

Power-Supply:

The TRXPTC can be supplied with 12 V DC (range is approx. 9..16 V) or directly with 5 V digital supply-voltage. In the 12 V case the internal switching voltage regulator U12 is active. In the 5 V case the regulator is disconnected and inactive. The two possibilities are selected by fitting in or leaving out Zero-Ohm resistors:

12 V operation: R36 and R37 fitted
R35 left out

5 V operation: R35 fitted
R36 and R37 left out

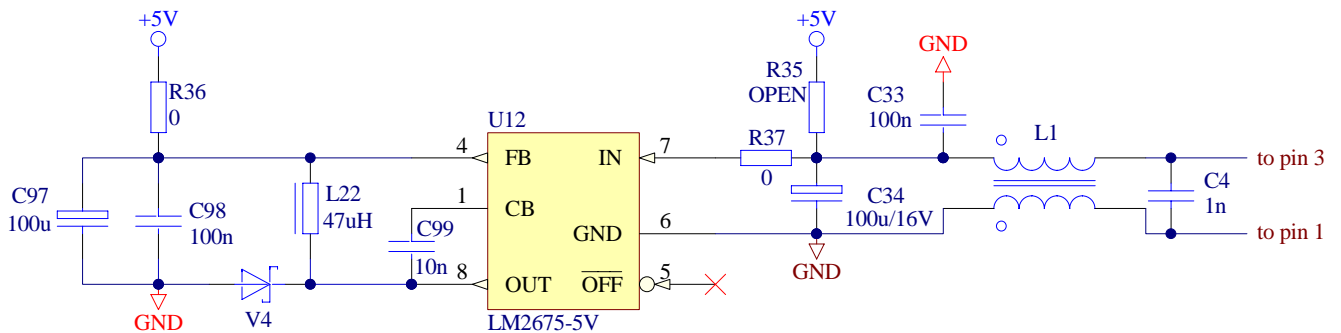

The schematic above shows the 12 V configuration.

BIOS

As all our modems, also the TRXPTC can be started in BIOS mode. This mode is for system recovery and troubleshooting. For more details refer to the manual of the PTC-IIusb.

To enter the BIOS mode, connect the 2 pads together before you apply power to the board:

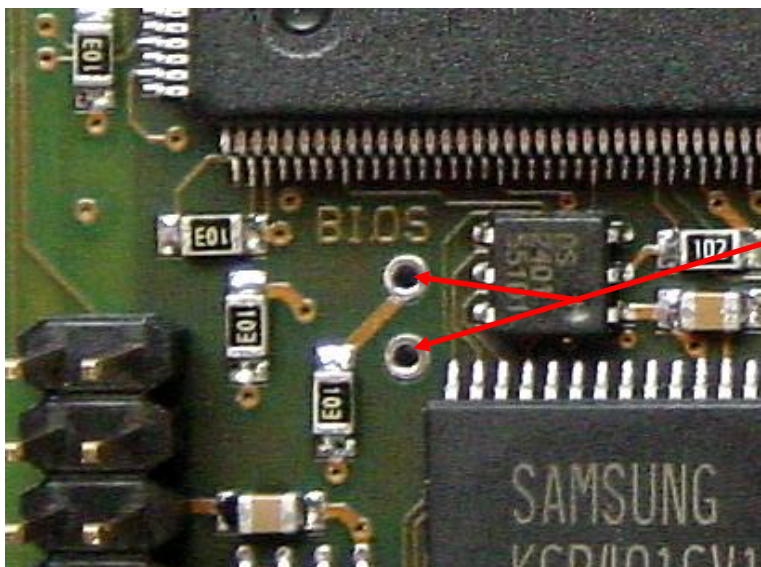

BIOS Switch

LED's:

The TRXPTC has 3 LED's which indicate basic operation modes.

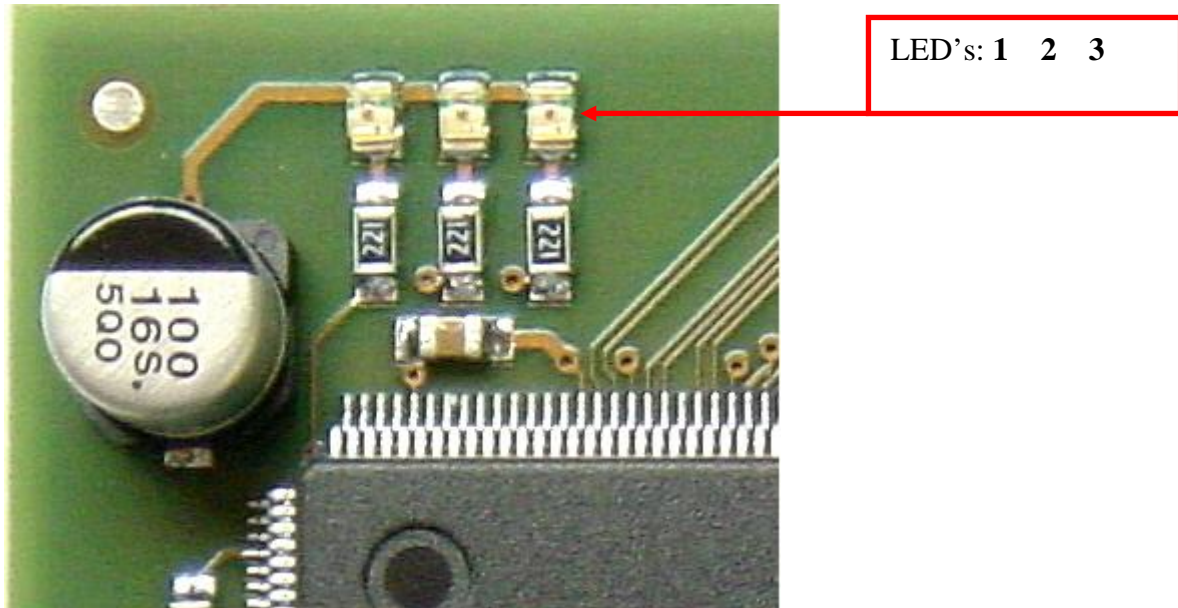

The LED's have the following meaning:

In BIOS mode:

- LED 1: Lits permanently when BIOS mode is activated.
- LED 2: Lits permanently when a Bluetooth connection is established.
- LED 3: Blinks when a firmware update is in progress.

In normal operation mode (firmware started):

- LED 1: Blinks fast and bright when firmware is in autobaud mode (non Bluetooth).
Blinks slower (1..2 per second) when a Bluetooth connect is waited for.
Flashes short and dim when the firmware is in STBY mode, ready to operate as HF-modem (e.g. ready to receive a connect).
- LED 2: Lits permanently when a Bluetooth connection is established.
- LED 3: Blinks when a firmware update is in progress.

Bluetooth transceiver:

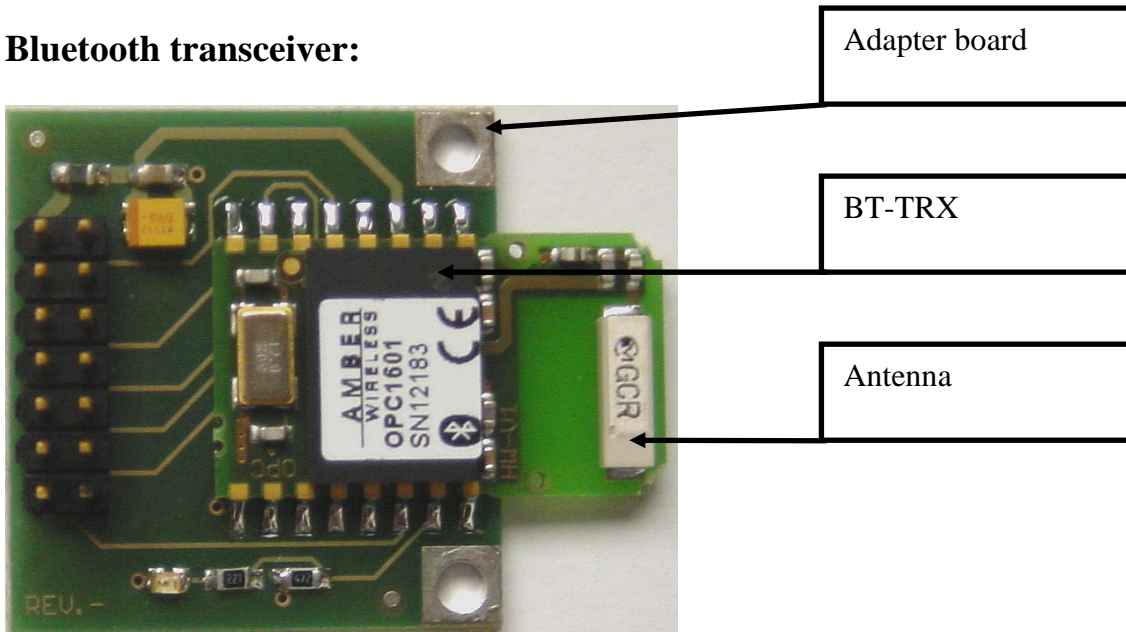

The Bluetooth transceiver unit consists of an adapter-board which is sized 32 x 30 mm. On this adapter-board the BT-TRX is soldered in a way, that the antenna of the BT-TRX hangs over around 10.5 mm. The antenna part of the device can be seen on the right hand. It is designed to stick out of the housing of the HF-radio through a slot in it's rear panel. For this, a slot of 19.5 x 6 mm in the radio's backpanel is necessary. A plastic-cap then can cover the antennae the way it is also the case with the PTC-IIusb with Bluetooth option (picture below).

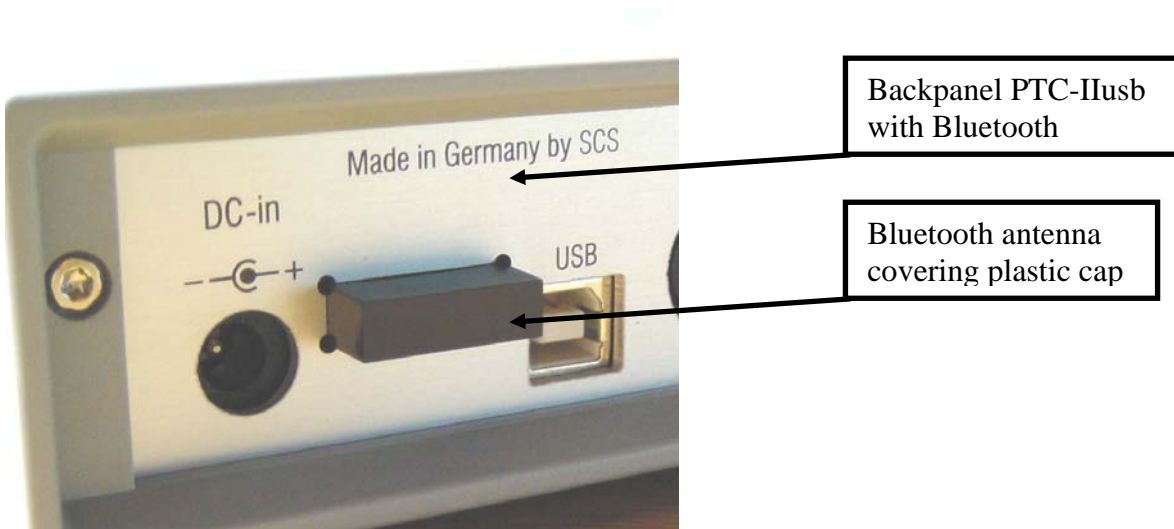

Component location plans:

Top Side:

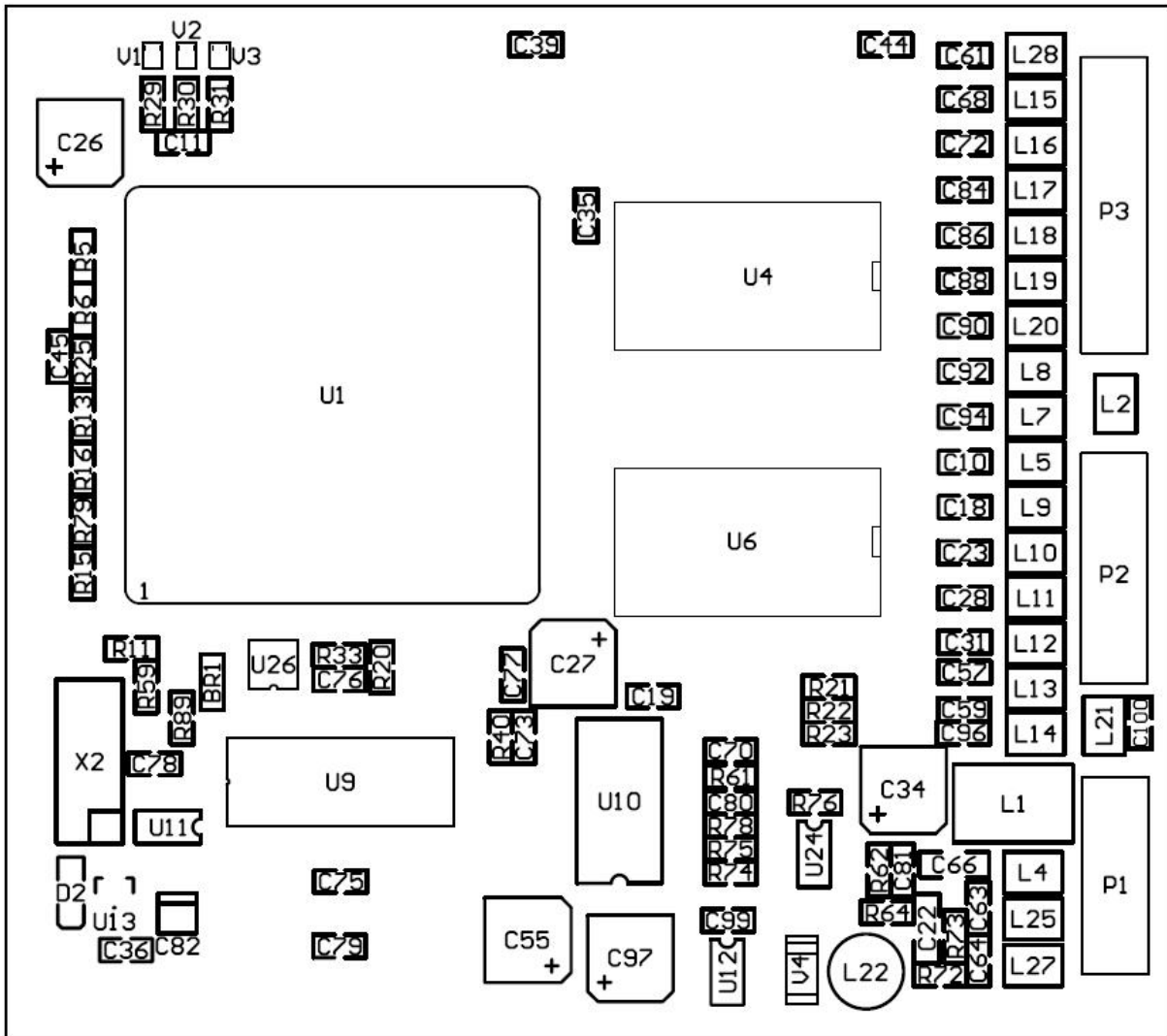

Bottom Side

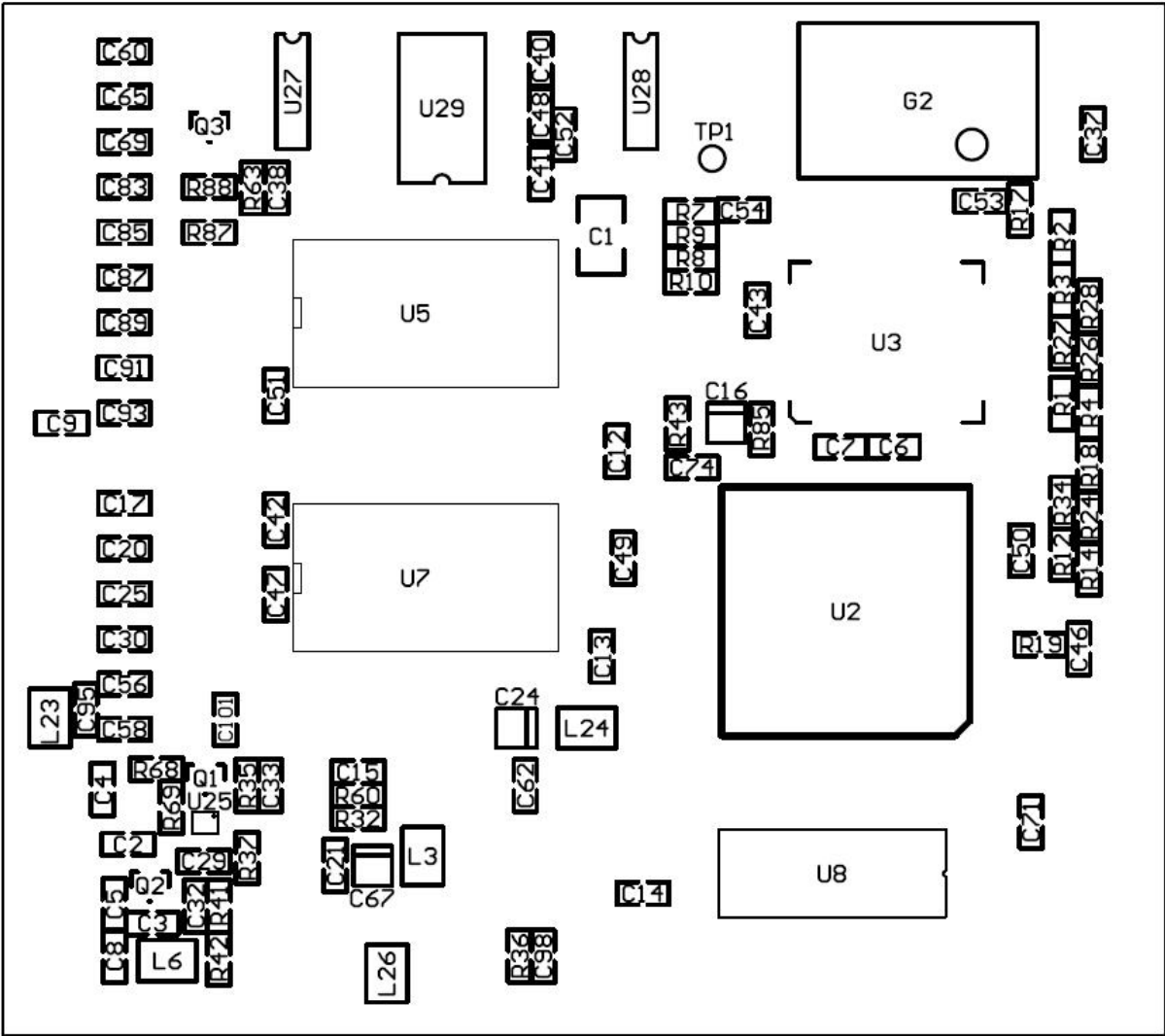

Testadapter:

With the help of the TRXPTC testadapter the TRXPTC can be operated like a normal, external modem with the usual connectors and RS232 port. The testadapter is available optionally.

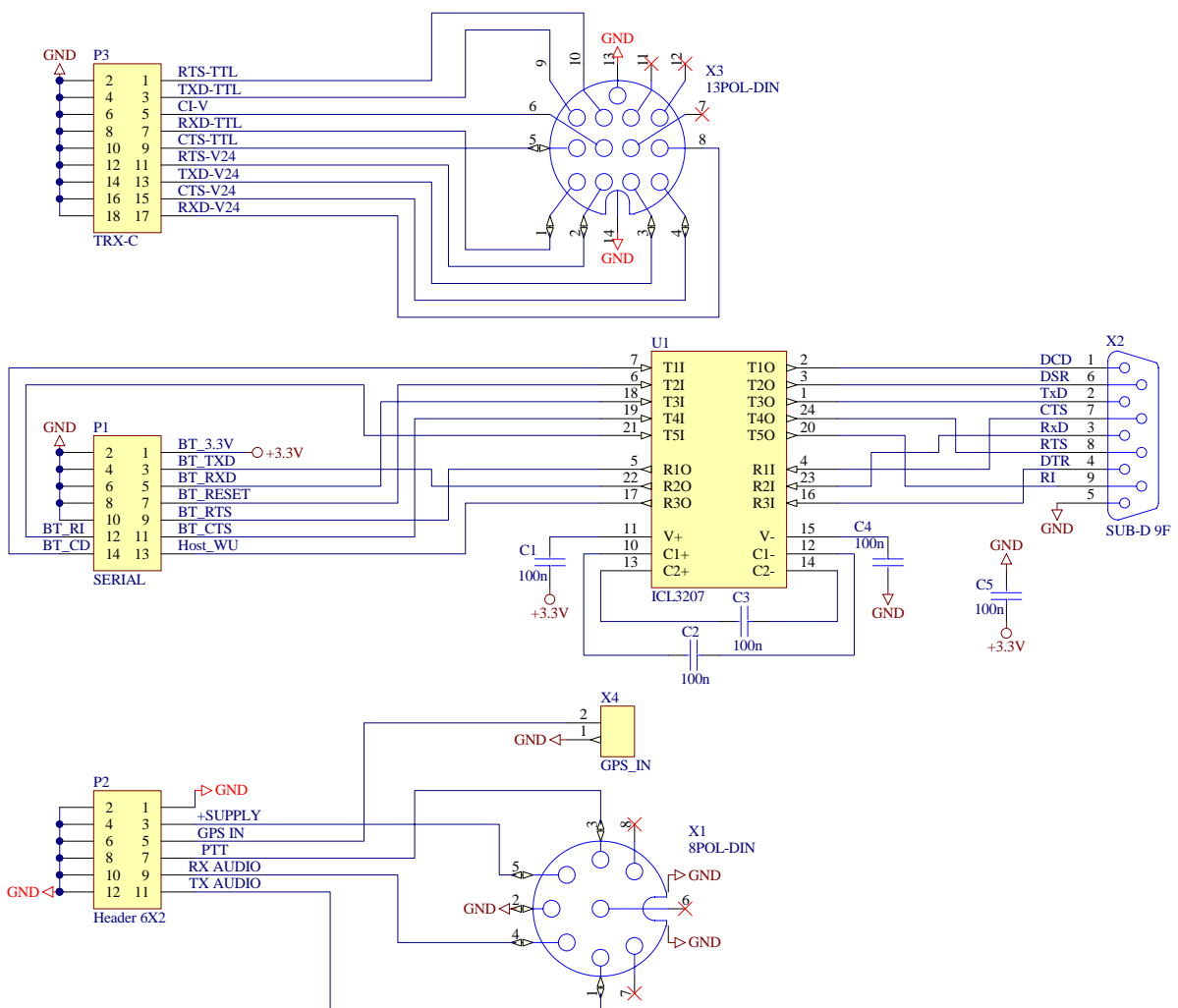
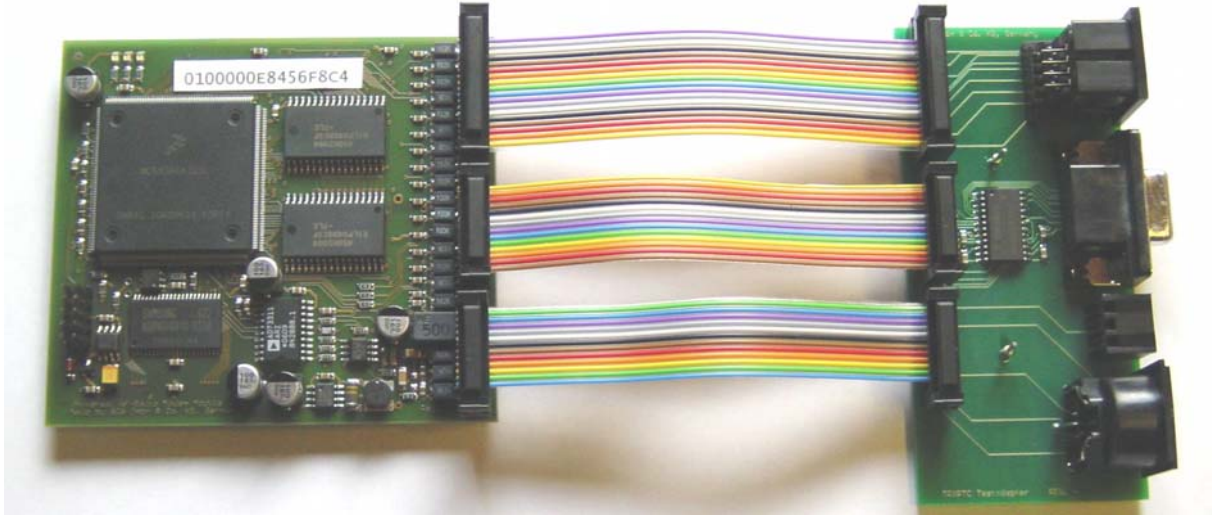

Basic Technical Data

Audio input impedance:	47 k Ω
Audio input level:	10 mVp-p... 2Vp-p
Audio output impedance:	1 k Ω
Audio output level:	Max. 3 Vp-p (open circuit), adjustable in 1 mV steps.
Audio processing:	Digital signal processor DSP56303 clocked at 100 MHz 768 kByte additional DSP-RAM for data and program.
Central processor:	Motorola MC68360 QUICC 32 bit CMOS CPU clocked at 25 MHz
ROM:	Max. 256 kByte, CMOS, Flash FLASH-ROM for easy updates
RAM:	static: 2 MByte, CMOS
System monitoring:	With an internal processor watchdog.
Power Supplies:	+9 to +16 V DC, or regulated 5 V DC, dependent on configuration. Max. 1.8 W power consumption
Dimensions:	Width 80 mm, Height 15 mm, Depth 90 mm
Weight:	60 g
Operating temperature:	-10 to +60 °C, humidity non condensing