

POWER SUPPLY

MODEL XP-15



7 56619 00944 5



Instruction Manual

ELENCO®

SPECIFICATIONS FOR XP-15 POWER SUPPLY

Output Voltage	0 - 15VDC
Output Current	0.3A @ 12V, 0.2A @ 15V
Load Regulation	0.1V
Line Regulation	0.1V
Ripple Max.	0.01V rms
Short Protection	IC THERMO
Output Impedance	0.3Ω

CIRCUIT DESCRIPTION

INTRODUCTION

The XP-15 Power Supply features an output voltage variable from 0 to 15V at 0.3 ampere maximum current. The voltage is regulated to within 0.1V when going from no load to full load. Varying the input AC voltage from 110 to 130V will have practically no effect on the output voltage. This is because of the specially designed IC circuit used in the XP-15. Severe overloading or even short circuiting the output will not damage the supply. Special turn-off circuits in the IC sense the overload and turn off the output.

Figure 1 shows a simplified circuit diagram of the power supply. It consists of a power transformer, a DC rectifier stage and the regulator stage.

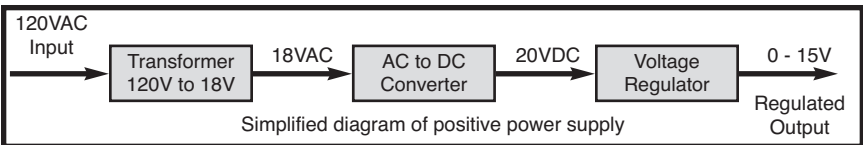

Figure 1

TRANSFORMER

The transformer T1 serves two purposes. First, it reduces the 120VAC input to 18VAC to allow the proper voltage to enter the rectifier stage. Second, it isolates the power supply output from the 120VAC line. This prevents the user from dangerous voltage shock should they be standing in a grounded area.

AC to DC CONVERTER

The AC to DC converter consists of diodes D1 and D3 and capacitor C1. Transformer T1 has two secondary windings which are 180 degrees out of phase. The AC output of each winding is shown in Figure 2A and 2B.

Diodes are semiconductor devices that allow current to flow in one direction. The arrow in Figure 3 points to the direction that the current will flow. Only when the transformer voltage is positive will current flow through the diodes. Figure 3 shows the simplest possible rectifier circuit. This circuit is known as a half wave rectifier. Here, the diode conducts only half the time when the AC wave is positive as shown in Figure 2C. Use of this circuit is simple but inefficient. The big gap between cycles requires much more filtering to obtain a smooth DC voltage.

By the addition of a second diode and transformer winding, we can fill in the gap between cycles as shown in Figure 4. This circuit is called full wave rectification. Each diode conducts when the voltage is positive. By adding the two outputs, the voltage presented to capacitor C1 is more complete, thus, easier to filter, as shown in Figure 2F. When used in 60 cycles AC input power, the output of a full wave rectifier will be 120 cycles.

Capacitor C1 is used to store the current charges, thus smoothing the DC voltage. The larger the capacitor, the more current is stored. In this design, a 2,200 μ F capacitor is used, which allows about 2 volts of AC ripple when one half amp is drawn.

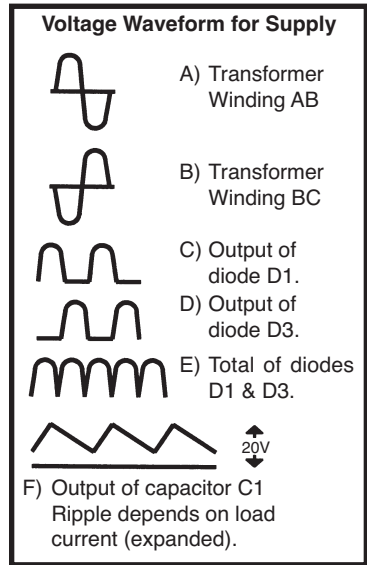

Figure 2

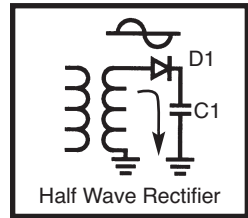

Figure 3

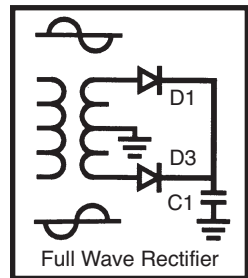

Figure 4

In practice, the current through the diodes is not as shown in Figure 2E. Because capacitor C1 has a charge after the first cycle, the diode will not conduct until the positive AC voltage exceeds the positive voltage in the capacitor. Figure 5 shows a better picture of what the current flow looks like, assuming no loss in the diode.

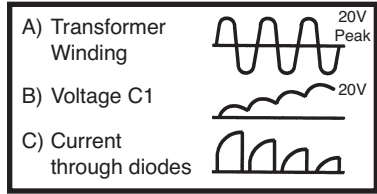

Figure 5

It takes a few cycles for the voltage to build up on the capacitor. This depends on the resistance of the winding and diode. After the initial start-up, there will be a charge and discharge on the capacitor depending on the current drawn by the output load. Remember, current only flows through the diode when the anode is more positive than the cathode. Thus, current will flow in short bursts as shown in Figure 5C.

The DC load current may be one ampere, but the peak diode current may be three times that. Therefore, the diode rating must be sufficient to handle the peak current. The 1N4001 has a peak current rating of 10 amps.

REGULATOR CIRCUIT

The regulator circuit in the Model XP-15 Power Supply consists of a LM317 integrated circuit. This IC is specially designed to perform the regulation function. Figure 6 shows a simplified circuit of how the LM317 IC works.

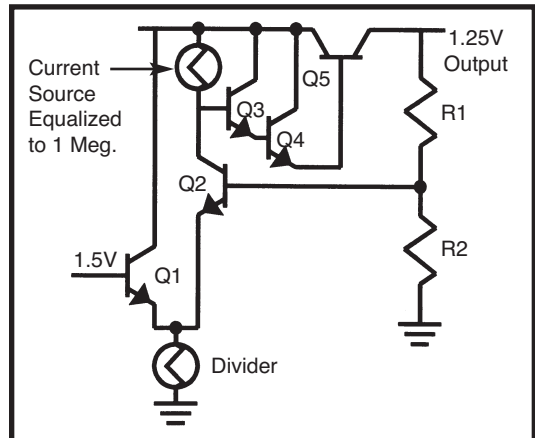

Figure 6

Transistors Q1 and Q2 form a circuit known as a differential amplifier. Transistor Q1's base is connected to a stable 1.5V reference voltage. The base of Q2 is connected to the regulator output circuit through a voltage divider network. The collector of transistor Q2 is connected to a current source. This basically is a PNP transistor biased to draw about 1mA current. Transistor Q2 sees the current source as a very high resistor of about 1 meg ohms. Thus, the gain of transistor Q2 is very high.

Transistor Q5 is called the pass transistor. It controls the current reaching the output. Transistors Q3 and Q4 are emitter followers. Their function is to raise the impedance of the pass transistor. Note that transistor Q2, Q3, Q4, Q5 and resistor R1 form a closed loop. Also, note that the feedback to the base of Q2 is negative, that is, the output at emitter Q5 goes negative. Now, if the 1.25V output voltage goes down because of current drain at the output, the base of Q2 will drop, forcing the collector voltage of Q2 to go higher. This will bring the output voltage back to 1.25V. This is the basis of all negative feedback regulators.

Another feature of the LM317 regulator is to protect the IC against overload and output shorts. If the IC is overloaded, the junction will overheat. A transistor will sense this overheating and shut down transistor Q5.

The LM317 IC is basically a 1.25V regulator. To be able to vary the output 0 - 15V, we stack the IC on the negative 1.25VDC voltage as shown in Figure 7. When R3 equals 0, the output voltage is 0 volts.

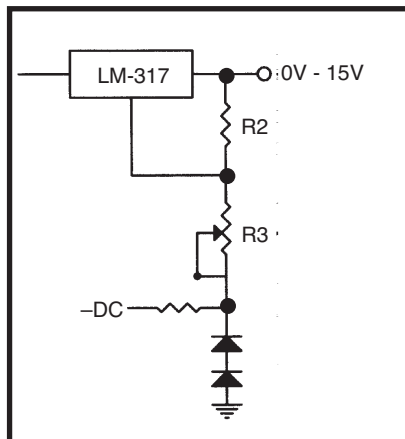
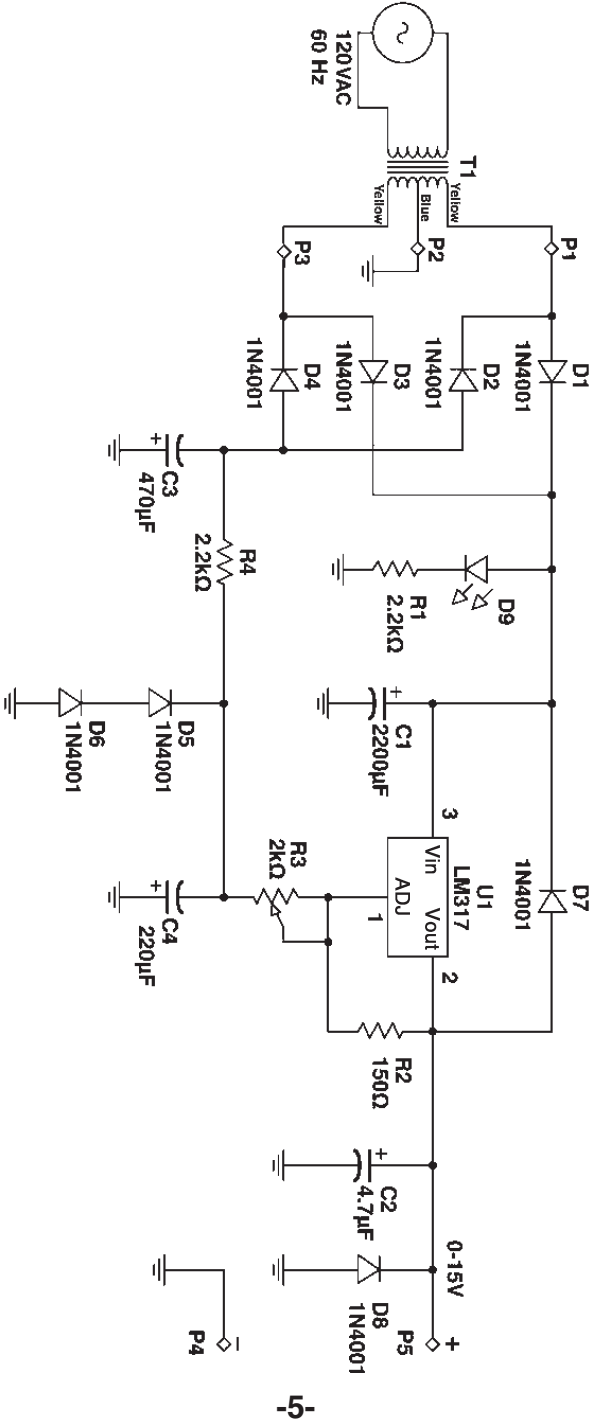

Figure 7

SCHEMATIC DIAGRAM



REV-A

PARTS LIST

RESISTORS

Qty.	Symbol	Description	Part #
<input type="checkbox"/> 1	R2	150 Ω 5% 1/4W	131500
<input type="checkbox"/> 2	R1, R4	2.2k Ω 5% 1/4W	142200
<input type="checkbox"/> 1	R3	2k Ω Potentiometer	192421

CAPACITORS

Qty.	Symbol	Description	Part #
<input type="checkbox"/> 1	C2	4.7 μ F 50V Electrolytic	264747
<input type="checkbox"/> 1	C4	220 μ F 16V Electrolytic	282244
<input type="checkbox"/> 1	C3	470 μ F 35V Electrolytic	284746
<input type="checkbox"/> 1	C1	2,200 μ F 35V Electrolytic	292226

SEMICONDUCTORS

Qty.	Symbol	Description	Part #
<input type="checkbox"/> 8	D1-8	1N4001 Diode	314001
<input type="checkbox"/> 1	U1	LM317 Regulator	330317
<input type="checkbox"/> 1	D9	LED Red	350002

MISCELLANEOUS

Qty.	Symbol	Part #
<input type="checkbox"/> 1	Transformer YD-1485	440111
<input type="checkbox"/> 1	PC board.....	510002
<input type="checkbox"/> 1	Heat sink.....	615009
<input type="checkbox"/> 1	Knob.....	622009
<input type="checkbox"/> 1	Case top.....	623061
<input type="checkbox"/> 1	Case bottom.....	623062
<input type="checkbox"/> 1	Strain relief 2-wire.....	624002
<input type="checkbox"/> 1	Binding post black.....	625031
<input type="checkbox"/> 2	Nut binding post.....	625031HN
<input type="checkbox"/> 2	Lockwasher binding post.....	625031LW
<input type="checkbox"/> 1	Binding post red.....	625032
<input type="checkbox"/> 4	Screw 3 x 8mm	641102
<input type="checkbox"/> 1	Screw 4-40 x 1/4".....	641430
<input type="checkbox"/> 2	Screw 6-32 x 3/8" Blk.....	641652
<input type="checkbox"/> 1	Nut 7mm.....	644101
<input type="checkbox"/> 1	Nut 4-40.....	644400
<input type="checkbox"/> 2	Nut 6-32.....	644600
<input type="checkbox"/> 1	Washer flat 8 x 14mm.....	645101
<input type="checkbox"/> 4	Washer fiber #6.....	645602
<input type="checkbox"/> 2	Lockwasher #6.....	646600
<input type="checkbox"/> 4	Rubber foot.....	662015
<input type="checkbox"/> 1	Label top.....	723071
<input type="checkbox"/> 1	Line cord 2 wire.....	862100
<input type="checkbox"/> 2"	Shrink tubing.....	890120

TWO YEAR WARRANTY

All Elenco® models are guaranteed for two full years on all parts and service. For the first 3 months, your power supply is covered at absolutely no charge. For the remaining 21 months, a nominal service charge is required to cover shipping and handling.

When returning merchandise for repair, please include proof of purchase, a brief letter of explanation of problem, and sufficient packing material. Before returning any merchandise please call our service department at (847) 541-3800 to obtain a return authorization number (RMA).

ELENCO®

150 Carpenter Ave.
Wheeling, IL 60090
(847) 541-3800

Website: www.elenco.com
e-mail: elenco@elenco.com