

HONDA

Power

Equipment

Owner's Manual

GENERATOR

EU2000i

Click here to save this manual to your computer.

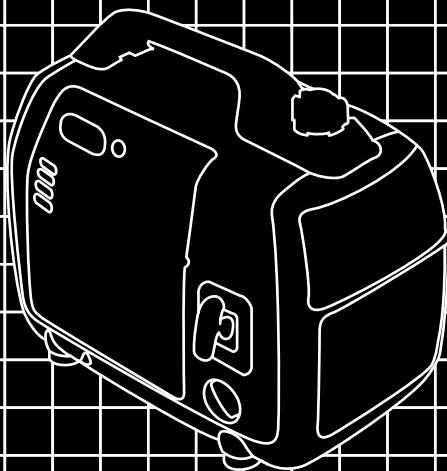



WARNING:



The engine exhaust from this product contains chemicals known to the State of California to cause cancer, birth defects or other reproductive harm.

▲WARNING

Exhaust contains poisonous carbon monoxide gas that can build up to dangerous levels in closed areas.

Breathing carbon monoxide can cause unconsciousness or death.

Never run the generator in a closed or even partially closed area where people may be present.

▲WARNING

The generator is a potential source of electrical shock if misused. Do not expose the generator to moisture, rain or snow. Do not let the generator get wet, and do not operate it with wet hands.

Keep this owner's manual handy, so you can refer to it at any time. This owner's manual is considered a permanent part of the generator and should remain with the generator if resold.

The information and specifications included in this publication were in effect at the time of approval for printing. Honda Motor Co., Ltd. reserves the right, however, to discontinue or change specifications or design at any time without notice and without incurring any obligation whatever. No part of this publication may be reproduced without written permission.

INTRODUCTION

Congratulations on your selection of a Honda generator. We are certain you will be pleased with your purchase of one of the finest generators on the market.

We want to help you get the best results from your new generator and to operate it safely. This manual contains the information on how to do that; please read it carefully.

As you read this manual, you will find information preceded by a **NOTICE** symbol. That information is intended to help you avoid damage to your generator, other property, or the environment.

We suggest you read the *Distributor's Limited Warranty* to fully understand its coverage and your responsibilities of ownership. The *Distributor's Limited Warranty* is a separate document that should have been given to you by your dealer.

When your generator needs scheduled maintenance, keep in mind that your Honda servicing dealer is specially trained in servicing Honda generators. Your authorized Honda servicing dealer is dedicated to your satisfaction and will be pleased to answer your questions and concerns.

Best Wishes,
Honda Motor Co., Ltd.

A FEW WORDS ABOUT SAFETY

Your safety and the safety of others are very important. And using this generator safely is an important responsibility.

To help you make informed decisions about safety, we have provided operating procedures and other information on labels and in this manual. This information alerts you to potential hazards that could hurt you or others.

Of course, it is not practical or possible to warn you about all the hazards associated with operating or maintaining a generator. You must use your own good judgement.

You will find important safety information in a variety of forms, including:

- **Safety Labels** — on the generator.
- **Safety Messages** — preceded by a safety alert symbol  and one of three signal words, DANGER, WARNING, or CAUTION.

These signal words mean:

 **DANGER**

You **WILL** be **KILLED** or **SERIOUSLY HURT** if you don't follow instructions.

 **WARNING**

You **CAN** be **KILLED** or **SERIOUSLY HURT** if you don't follow instructions.

 **CAUTION**

You **CAN** be **HURT** if you don't follow instructions.

- **Safety Headings** — such as *IMPORTANT SAFETY INFORMATION*.
- **Safety Section** — such as *GENERATOR SAFETY*.
- **Instructions** — how to use this generator correctly and safely.

This entire book is filled with important safety information — please read it carefully.

GENERATOR SAFETY	5
Safety Label Locations	5
Important Safety Information	7
COMPONENT IDENTIFICATION	9
CONTROLS	11
Engine Switch	11
Starter Grip	11
Fuel Tank Cap Vent Lever	12
Choke Lever	12
Output Indicator Light	13
Overload Indicator Light	13
Oil Alert® System	14
Ground Terminal	14
Eco-Throttle™ Switch	15
Parallel Operation Outlets	15
AC Circuit Protector	16
DC Receptacle	16
DC Circuit Protector	16
GENERATOR USE	17
Connections to a Building Electrical System	17
Ground System	17
Special Requirements	18
AC Applications	19
AC Operation	20
AC Parallel Operation Applications	21
AC Parallel Operation	23
DC Operation	24
Eco-Throttle™ System	26
High Altitude Operation	27
PRE-OPERATION CHECK	28
Engine Oil	28
Refueling	30
Fuel Recommendations	32
STARTING THE ENGINE	33
STOPPING THE ENGINE	35

MAINTENANCE	36
The Importance of Maintenance	36
Maintenance Safety	37
Emission Control System Information	38
Air Index	40
Maintenance Schedule	41
Engine Oil Change	42
Air Cleaner Service	44
Spark Plug Service	46
Spark Arrester Maintenance	48
TRANSPORTING/STORAGE	50
Transporting	50
Storage	51
TROUBLESHOOTING	54
WIRING DIAGRAM	56
INITIAL USE INSTRUCTIONS	57
Adding Engine Oil	57
Adding Fuel	58
SPECIFICATIONS	61
TECHNICAL & CONSUMER INFORMATION	62
Customer Service Information	62
Distributor's Limited Warranty	64
Emission Control System Warranty	65
INDEX	70

GENERATOR SAFETY



SAFETY LABEL LOCATIONS

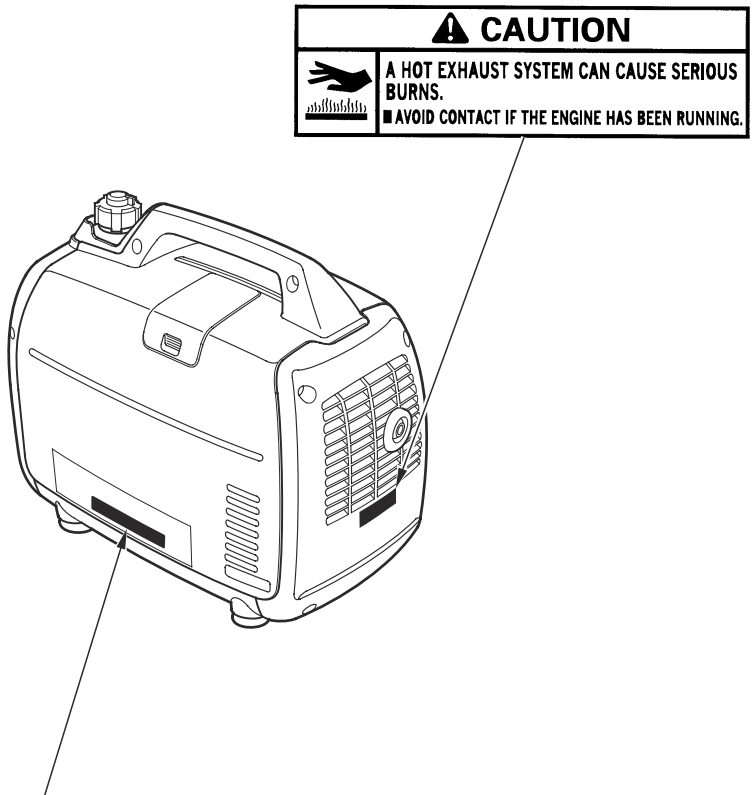

These labels warn you of potential hazards that can cause serious injury. Read them carefully.

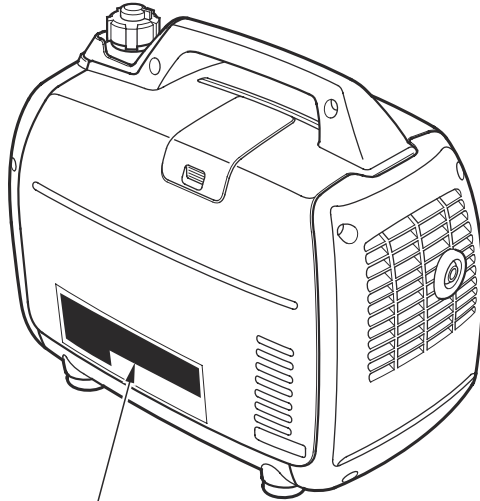
If a label comes off or becomes hard to read, contact your Honda generator dealer for a replacement.





⚠ WARNING	
	<p>GASOLINE IS HIGHLY FLAMMABLE AND EXPLOSIVE. YOU COULD BE BURNED OR SERIOUSLY INJURED IF THE GASOLINE IS IGNITED.</p> <ul style="list-style-type: none"> ■ STOP THE ENGINE AND KEEP HEAT, SPARKS, AND FLAME AWAY. ■ HANDLE FUEL ONLY OUTDOORS. ■ DO NOT FILL THE FUEL TANK ABOVE THE UPPER LIMIT LINE. ■ WIPE UP SPILLS IMMEDIATELY. ■ AFTER OPERATION, TURN THE ENGINE SWITCH AND FUEL TANK CAP LEVER TO THE "OFF" POSITION PREVENT FUEL LEAKAGE.
	<p>EXHAUST CONTAINS POISONOUS CARBON MONOXIDE GAS THAT CAN BUILD UP TO DANGEROUS LEVELS IN CLOSED AREAS. BREATHING CARBON MONOXIDE CAN CAUSE UNCONSCIOUSNESS OR DEATH.</p> <ul style="list-style-type: none"> ■ NEVER RUN THE GENERATOR IN A CLOSED, OR EVEN PARTLY CLOSED, AREA WHERE PEOPLE MAY BE PRESENT.

⚠ WARNING	
	<p>IMPROPER CONNECTIONS TO A BUILDING CAN ALLOW ELECTRICAL CURRENT TO BACKFEED INTO UTILITY LINES, CREATING AN ELECTROCUTION HAZARD.</p> <ul style="list-style-type: none"> ■ CONNECTIONS TO A BUILDING MUST ISOLATE GENERATOR POWER FROM UTILITY POWER AND COMPLY WITH ALL APPLICABLE LAWS AND ELECTRICAL CODES.
	<p>THE GENERATOR IS A POTENTIAL SOURCE OF ELECTRICAL SHOCK IF NOT KEPT DRY.</p> <ul style="list-style-type: none"> ■ DO NOT EXPOSE THE GENERATOR TO MOISTURE, RAIN OR SNOW. ■ DO NOT OPERATE THE GENERATOR WITH WET HANDS.

IMPORTANT SAFETY INFORMATION

Honda generators are designed to give safe and dependable service if operated according to instructions. Read and understand this owner's manual before operating your generator. You can help prevent accidents by being familiar with your generator's controls, and by observing safe operating procedures.

Operator Responsibility

- Know how to stop the generator quickly in case of emergency.
- Understand the use of all generator controls, output receptacles, and connections.
- Be sure that anyone who operates the generator receives proper instruction. Do not let children operate the generator without parental supervision.

Carbon Monoxide Hazards

- Exhaust contains poisonous carbon monoxide, a colorless and odorless gas. Breathing carbon monoxide can cause loss of consciousness and may lead to death.
- If you run the generator in an area that is confined, or even partially enclosed area, the air you breathe could contain a dangerous amount of exhaust gas.
- Never run your generator inside a garage, house or near open windows or doors.

Electric Shock Hazards

- The generator produces enough electric power to cause a serious shock or electrocution if misused.
- Using a generator or electrical appliance in wet conditions, such as rain or snow, or near a pool or sprinkler system, or when your hands are wet, could result in electrocution. Keep the generator dry.
- If the generator is stored outdoors, unprotected from the weather, check all of the electrical components on the control panel before each use. Moisture or ice can cause a malfunction or short circuit in electrical components which could result in electrocution.
- Do not connect to a building electrical system unless an isolation switch has been installed by a qualified electrician.
- Use only a Honda approved parallel operation kit (optional equipment) when connecting two EU2000i generators for parallel operation.
- Never connect different generator models and types.

Fire and Burn Hazards

- The exhaust system gets hot enough to ignite some materials.
 - Keep the generator at least 3 feet (1 meter) away from buildings and other equipment during operation.
 - Do not enclose the generator in any structure.
 - Keep flammable materials away from the generator.
- The muffler becomes very hot during operation and remains hot for a while after stopping the engine. Be careful not to touch the muffler while it is hot. Let the engine cool before storing the generator indoors.
- Gasoline is extremely flammable and is explosive under certain conditions. Do not smoke or allow flames or sparks where the generator is refueled or where gasoline is stored. Refuel in a well-ventilated area with the engine stopped.
- Fuel vapors are extremely flammable and may ignite after the engine has started. Make sure that any spilled fuel has been wiped up before starting the generator.

COMPONENT IDENTIFICATION

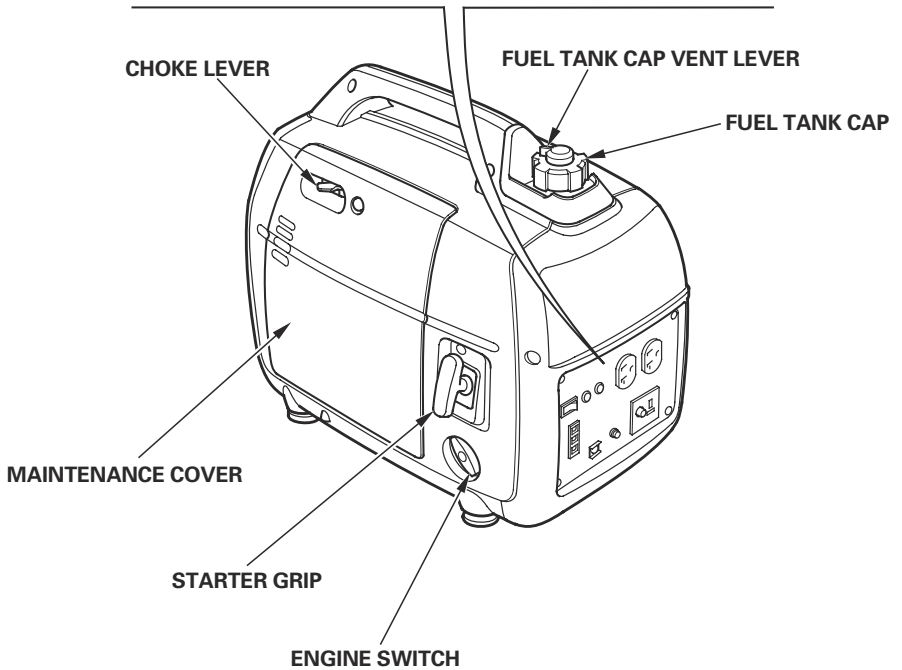
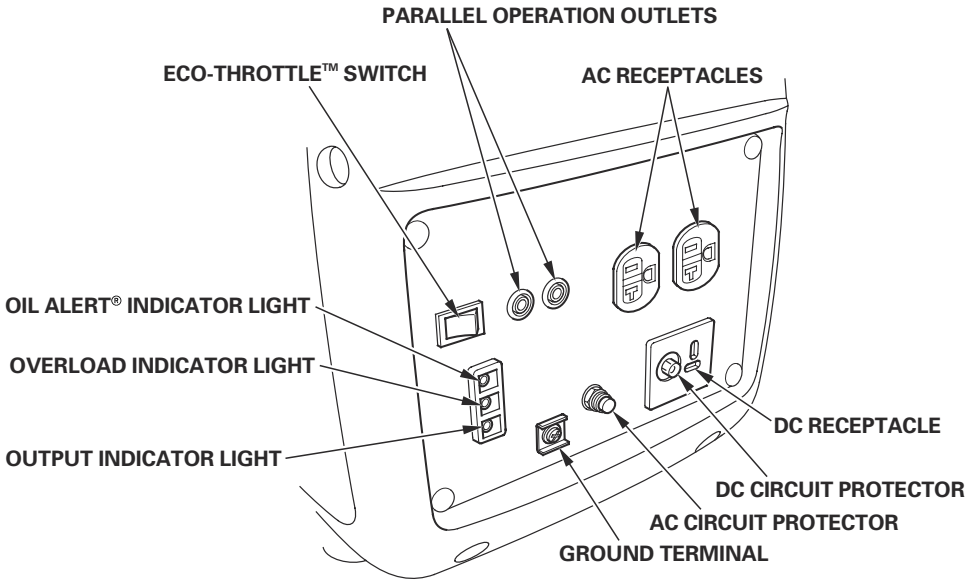

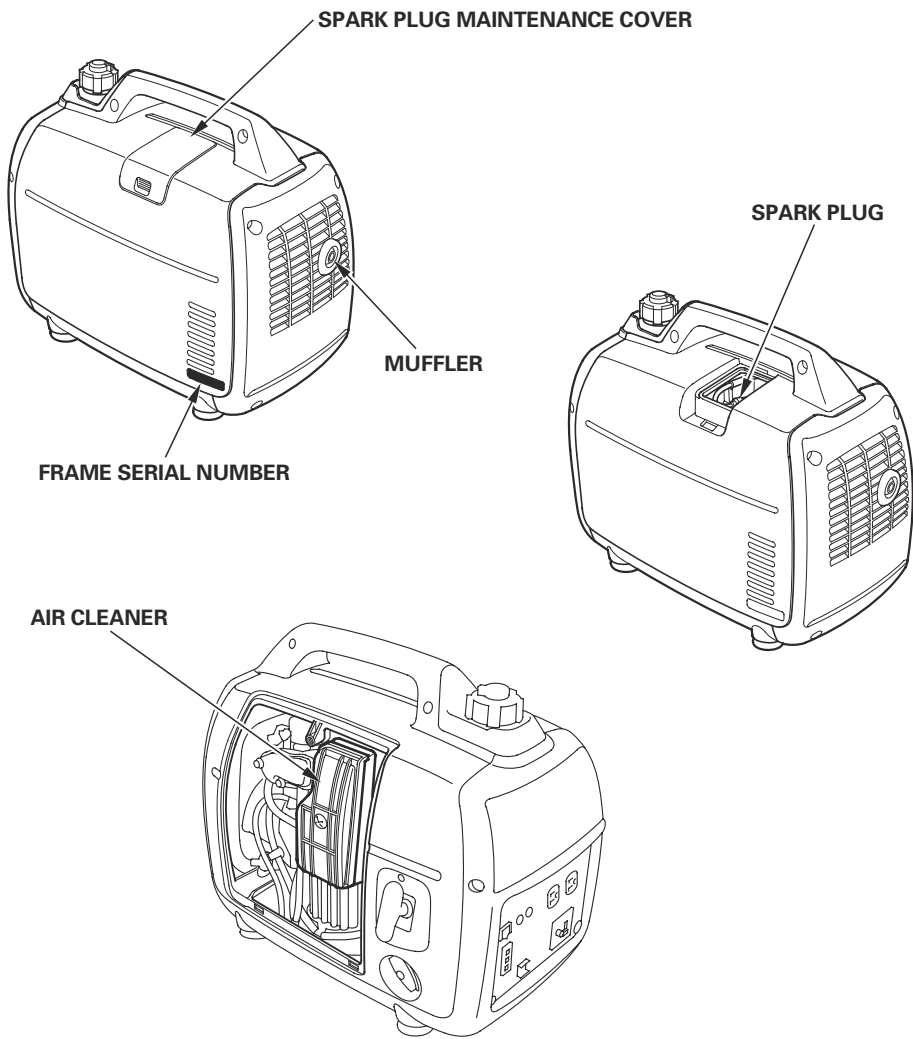

Record the frame serial number for your future reference. Refer to this serial number when ordering parts, and when making technical or warranty inquiries (see page 62).

Frame serial number: _____

Date purchased: _____

ENGINE SWITCH

To start and stop the engine.

Switch position:

OFF: To stop the engine.

ON: To start and run the engine.

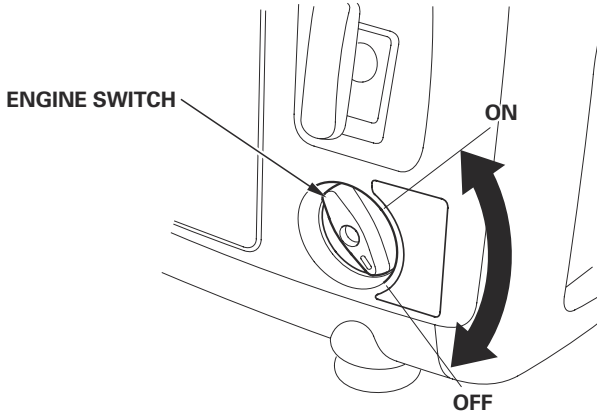

STARTER GRIP

To start the engine, pull the starter grip lightly until you feel resistance, then pull briskly in the direction of the arrow as shown below.

NOTICE

Do not allow the starter grip to snap back against the engine. Return it gently to prevent damage to the starter.

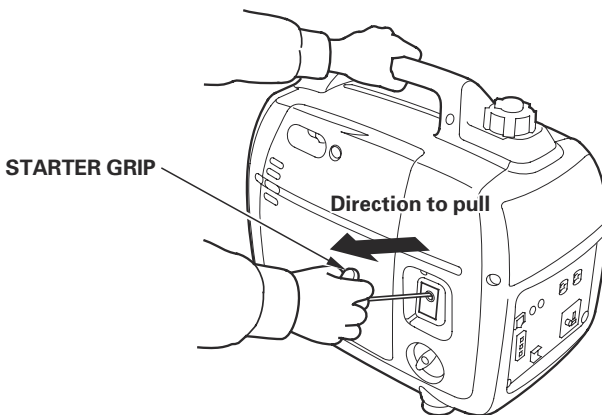

FUEL TANK CAP VENT LEVER

The fuel tank cap is provided with a vent lever to seal the fuel tank.

The vent lever must be in the ON position for the engine to run.

When the engine is not in use, leave the vent lever in the OFF position to reduce the possibility of fuel leakage. Allow the engine to cool well before turning the vent lever to the OFF position.

NON-CALIFORNIA TYPE

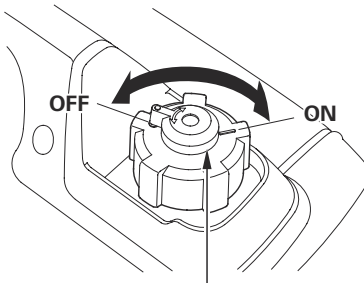

FUEL TANK CAP VENT LEVER

CALIFORNIA TYPE

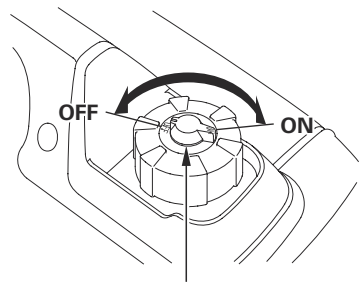

FUEL TANK CAP VENT LEVER

CHOKE LEVER

The choke is used to provide proper starting mixture when the engine is cold. It can be opened and closed by operating the choke lever manually. Move the choke lever to the CLOSED position to enrich the mixture for cold starting.

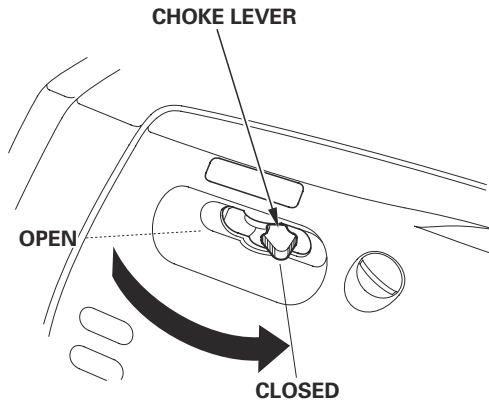

OUTPUT INDICATOR LIGHT

The output indicator light (green) is illuminated when the generator is operating normally. It indicates that the generator is producing electrical power at the receptacles.

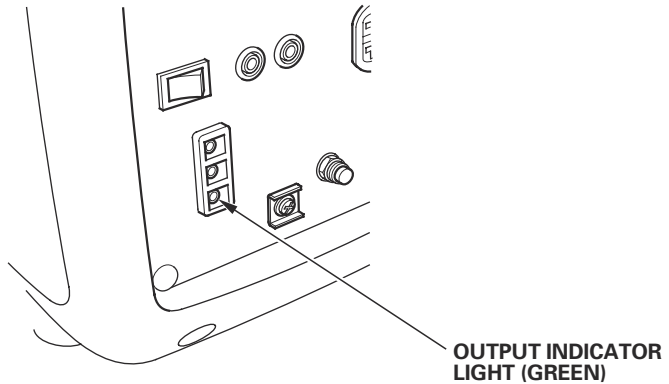

OVERLOAD INDICATOR LIGHT

If the generator is overloaded (in excess of 2,000 VA), or if there is a short circuit in a connected appliance, the overload indicator light (red) will go ON. The overload indicator light (red) will stay ON, and after about four seconds, current to the connected appliance(s) will shut off, and the output indicator light (green) will go OFF.

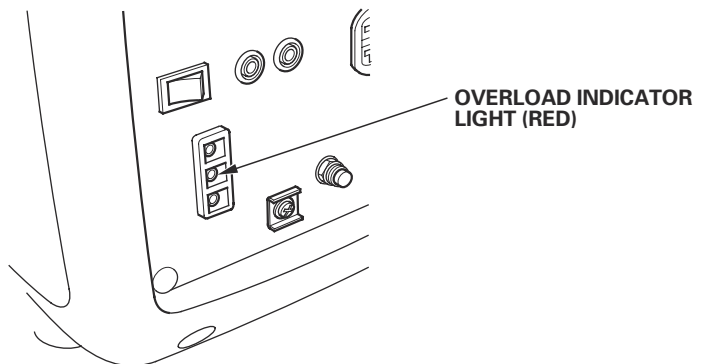

OIL ALERT® SYSTEM

The Oil Alert® system is designed to prevent engine damage caused by an insufficient amount of oil in the crankcase. Before the oil level in the crankcase can fall below a safe limit, the Oil Alert indicator light comes on and the Oil Alert system automatically will stop the engine (the engine switch will remain in the ON position).

If the engine stops or the Oil Alert indicator light comes on when you pull the starter grip, check the engine oil level (see page 28) before troubleshooting in other areas.



GROUND TERMINAL

The generator ground terminal is connected to the frame of the generator, the metal non-current-carrying parts of the generator, and the ground terminals of each receptacle.

Before using the ground terminal, consult a qualified electrician, electrical inspector or local agency having jurisdiction for local codes or ordinances that apply to the intended use of the generator.

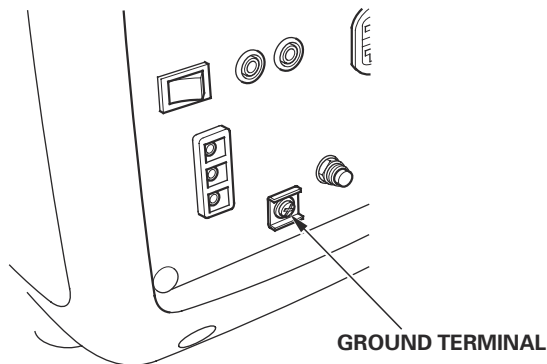

ECO-THROTTLE™ SWITCH

The Eco-Throttle™ system automatically reduces engine speed when all loads are turned off or disconnected. When appliances are turned on or reconnected, the engine returns to the proper speed to power the electrical load.

If high electrical loads are connected simultaneously, turn the Eco-Throttle switch to the OFF position to reduce voltage changes.

When using the DC output, turn the Eco-Throttle switch to the OFF position.

ON: Recommended to minimize fuel consumption and further reduce noise levels when no load is applied to the generator.

OFF: The Eco-Throttle system does not operate.

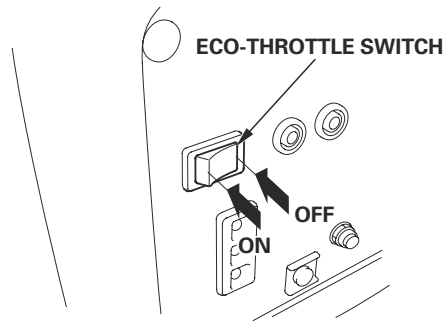

PARALLEL OPERATION OUTLETS

These outlets are used for connecting two EU2000i generators for parallel operation (see page 23). A Honda approved parallel operation kit (optional equipment) is required for parallel operation. This kit can be purchased from an authorized Honda generator dealer.

PARALLEL OPERATION OUTLETS

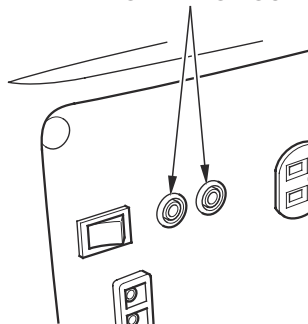

AC CIRCUIT PROTECTOR

The AC circuit protector will automatically switch OFF if there is a short circuit or a significant overload of the generator at the AC receptacles. If the circuit protector switches OFF automatically, check that the appliance is working properly and does not exceed the rated load capacity of the circuit before resetting the circuit protector ON.

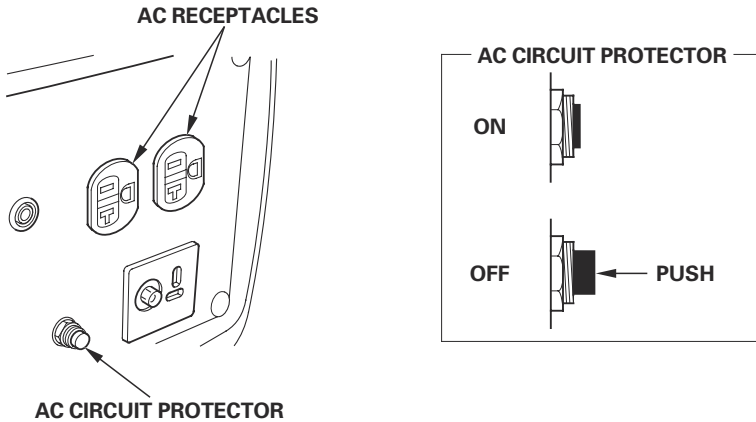

DC RECEPTACLE

The DC receptacle should ONLY be used for charging 12-volt automotive type batteries. The DC charging output is not regulated.

DC CIRCUIT PROTECTOR

The DC circuit protector automatically shuts off the DC battery charging circuit when the DC charging circuit is overloaded, when there is a problem with the battery, or when the connections between the battery and the generator are improper.

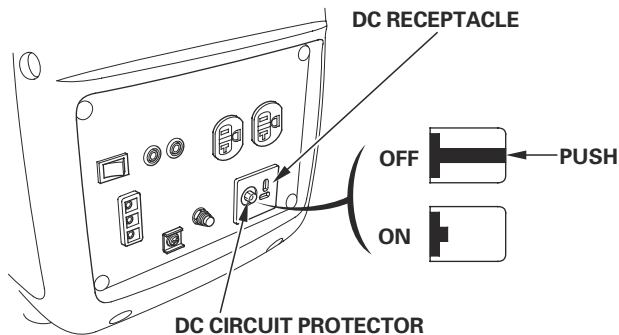

CONNECTIONS TO A BUILDING ELECTRICAL SYSTEM

Connections for standby power to a building electrical system must be made by a qualified electrician. The connection must isolate the generator power from utility power, and must comply with all applicable laws and electrical codes.

▲WARNING

Improper connections to a building electrical system can allow electrical current from the generator to backfeed into the utility lines. Such backfeed may electrocute utility company workers or others who contact the lines during a power outage, and the generator may explode, burn, or cause fires when utility power is restored. Consult the utility company or a qualified electrician.

GROUND SYSTEM

Honda portable generators have a system ground that connects generator frame components to the ground terminals in the AC output receptacles. The system ground is not connected to the AC neutral wire. If the generator is tested by a receptacle tester, it will not show the same ground circuit condition as for a home receptacle.

SPECIAL REQUIREMENTS

NOTICE

Keep all cooling holes open and clear of debris, mud, water, etc. Cooling holes are located on the side panel, the control panel, and the bottom of the generator. If the cooling holes are blocked, the generator may overheat and damage the engine, inverter, or windings.

NOTICE

Do not lay the generator on its side when moving, storing, or operating it. Oil may leak and damage the engine or your property.

There may be Federal or State Occupational Safety and Health Administration (OSHA) regulations, local codes, or ordinances that apply to the intended use of the generator. Please consult a qualified electrician, electrical inspector, or the local agency having jurisdiction.

- In some areas, generators are required to be registered with local utility companies.
- If the generator is used at a construction site, there may be additional regulations that must be observed.

AC APPLICATIONS

Before connecting an appliance or power cord to the generator:

- Make sure that it is in good working order. Faulty appliances or power cords can create a potential for electrical shock.
- If an appliance begins to operate abnormally, becomes sluggish or stops suddenly, turn it off immediately. Disconnect the appliance, and determine whether the problem is the appliance, or if the rated load capacity of the generator has been exceeded.
- Make sure that the electrical rating of the tool or appliance does not exceed that of the generator. Never exceed the maximum power rating of the generator. Power levels between rated and maximum may be used for no more than 30 minutes.

NOTICE

Substantial overloading will switch off the AC circuit protector. Exceeding the time limit for maximum power operation or slightly overloading the generator may not switch the AC circuit protector OFF, but will shorten the service life of the generator.

Limit operation requiring maximum power to 30 minutes.
Maximum power is:

2,000 VA

For continuous operation, do not exceed the rated power.
Rated power is:

1,600 VA

The total power requirements (VA) of all appliances connected must be considered. Appliance and power tool manufacturers usually list rating information near the model number or serial number.

AC OPERATION

1. Start the engine and make sure the output indicator light (green) comes on (see page 33).
2. Plug in the appliance.
Most motorized appliances require more than their rated wattage for startup.

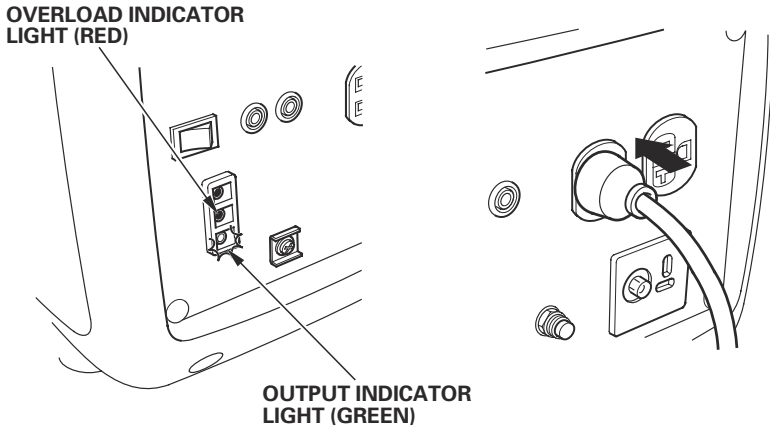

If the generator is overloaded (in excess of 2,000 VA), or if there is a short circuit in a connected appliance, the overload indicator light (red) will go ON. The overload indicator light (red) will stay ON, and after about four seconds, current to the connected appliance(s) will shut off, and the output indicator light (green) will go OFF. Stop the engine and investigate the problem.

Determine if the cause is a short circuit in a connected appliance or an overload. Correct the problem and restart the generator.

Before connecting an appliance to the generator, make sure that it is in good order and that its electrical rating does not exceed that of the generator. Then start the generator and connect the appliance power cord.

NOTICE

When an electric motor is started, the overload indicator light (red) may come on. This is normal if the overload indicator light (red) goes off after about four (4) seconds. If the overload indicator light (red) stays on, consult your Honda generator dealer.

AC PARALLEL OPERATION APPLICATIONS

Follow the instructions included with the parallel operation kit. Before connecting an appliance or power cord to the generator:

- Make sure that it is in good working order. Faulty appliances or power cords can create a potential for electrical shock.
- If an appliance begins to operate abnormally, becomes sluggish or stops suddenly, turn it off immediately. Disconnect the appliance, and determine whether the problem is the appliance, or if the rated load capacity of the generator has been exceeded.
- Make sure that the electrical rating of the tool or appliance does not exceed that of the generator. Never exceed the maximum power rating of the generator. Power levels between rated and maximum may be used for no more than 30 minutes.
- Never connect different generator models and types.
- Use only a Honda approved parallel operation kit (optional equipment) when connecting two EU2000i generators for parallel operation.
- Never connect or remove the parallel operation kit when the generator is running.
- For single generator operation, the parallel operation kit must be removed.

NOTICE

Substantial overloading that continuously lights the overload indicator light (red) may damage the generator. Marginal overloading that temporarily lights the overload indicator light (red) may shorten the service life of the generator.

Limit operation requiring maximum power to 30 minutes.
Maximum power in parallel operation is:

4.0 kVA

For continuous operation, do not exceed the rated power.
Rated power in parallel operation is:

3.2 kVA

The total power requirements (VA) of all appliances connected must be considered. Appliance and power tool manufacturers usually list rating information near the model number or serial number.

AC PARALLEL OPERATION

1. Connect the parallel operation kit between the two EU2000i generators following the instructions supplied with the kit.

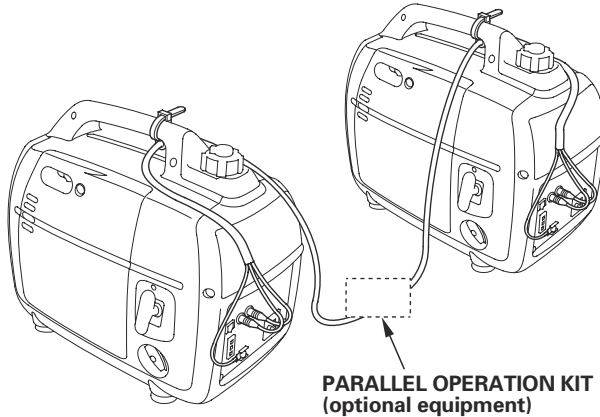

2. Start the generators and make sure the output indicator lights (green) come on (see page 33).
3. Plug in the appliance following the instructions provided with the parallel operation kit.
Most motorized appliances require more than their rated wattage for startup.

If the generators are overloaded (see page 22), or if there is a short circuit in a connected appliance, the overload indicator lights (red) will go ON. The overload indicator lights (red) will stay ON, and after about four seconds, current to the connected appliance(s) will shut off, and the output indicator lights (green) will go OFF. Stop the engines and investigate the problem.

DC OPERATION

The DC receptacle should **ONLY** be used for charging 12-volt automotive type batteries. The DC charging output is not regulated.

When using the DC output, turn the Eco-Throttle switch to the OFF position.

Connecting the battery charging cable (optional equipment):

1. Before connecting the battery charging cable to a battery that is installed in a vehicle, disconnect the vehicle battery ground cable from the negative (–) battery terminal.

▲WARNING

The battery gives off explosive gases; keep sparks, flames and cigarettes away. Provide adequate ventilation when charging or using batteries.

WARNING: Battery posts, terminals and related accessories contain lead and lead components. **Wash hands after handling.**

2. Plug the battery charging cable into the DC receptacle of the generator.
3. Connect the red lead of the battery charging cable to the positive (+) battery terminal and the black lead to the negative (–) battery terminal.

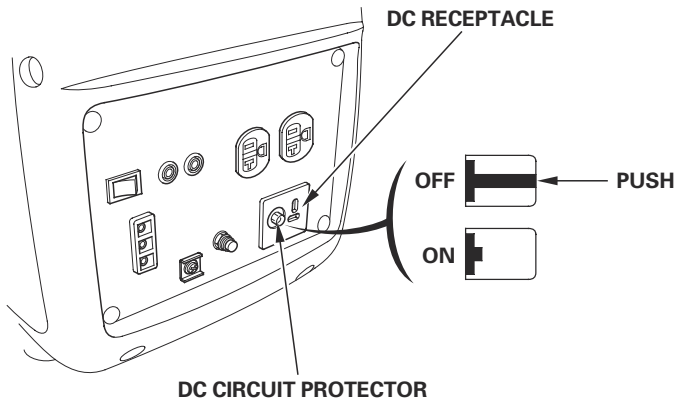

4. Start the generator.

NOTICE

Do not start the vehicle while the battery charging cable is connected and the generator is running. The vehicle or the generator may be damaged.

An overloaded DC circuit, excessive current draw by the battery, or a wiring problem will trip the DC circuit protector (PUSH button extends out). If this happens, wait a few minutes before pushing in the circuit protector to resume operation. If the DC circuit protector continues to go OFF, discontinue charging and see your authorized Honda generator dealer.

Disconnecting the battery charging cable:

1. Stop the engine.
2. Disconnect the black lead of the battery charging cable from the negative (–) battery terminal.
3. Disconnect the red lead of the battery charging cable from the positive (+) battery terminal.
4. Disconnect the battery charging cable from the DC receptacle of the generator.
5. Connect the vehicle battery ground cable to the negative (–) battery terminal.

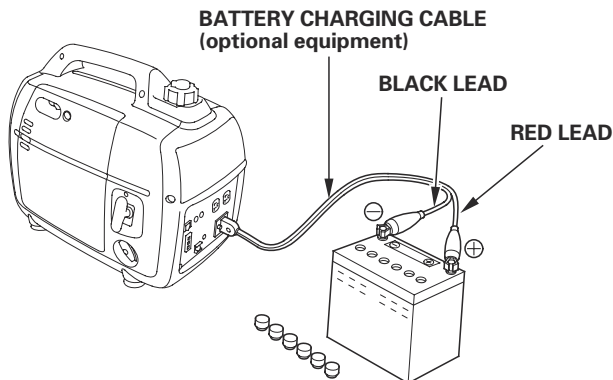

ECO-THROTTLE™ SYSTEM

With the switch in the ON position, engine speed is automatically lowered when loads are reduced, turned OFF or disconnected. When appliances are turned ON or reconnected, the engine returns to the proper speed to power the electrical load. In the OFF position, the Eco-Throttle™ system does not operate.

Appliances with large start-up power demands may not allow the engine to reach normal operating rpm when they are connected to the generator. Turn the Eco-Throttle to the OFF position and connect the appliance to the generator. If the engine still will not reach normal operating speed, check that the appliance does not exceed the rated load capacity of the generator.

If high electrical loads are connected simultaneously, turn the Eco-Throttle switch to the OFF position to reduce voltage changes.

The Eco-Throttle system is not effective for use with appliances that require only momentary power. If the tool or appliance will be turned ON and OFF quickly, the Eco-Throttle switch should be in the OFF position.

When using the DC output, turn the Eco-Throttle switch to the OFF position.

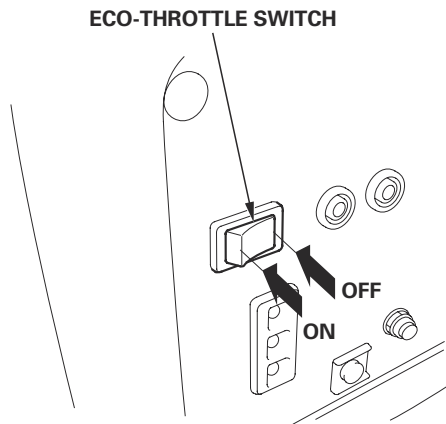

HIGH ALTITUDE OPERATION

At high altitude, the standard carburetor air/fuel mixture will be too rich. Performance will decrease, and fuel consumption will increase. A very rich mixture will also foul the spark plug and cause hard starting. Operation at an altitude that differs from that at which this engine was certified, for extended periods of time, may increase emissions.

High altitude performance can be improved by specific modifications to the carburetor. If you always operate your generator at altitudes above 5,000 feet (1,500 meters), have your servicing dealer perform this carburetor modification. This engine, when operated at high altitude with the carburetor modifications for high altitude use, will meet each emission standard throughout its useful life.

Even with carburetor modification, engine horsepower will decrease about 3.5% for each 1,000-foot (300-meter) increase in altitude. The effect of altitude on horsepower will be greater than this if no carburetor modification is made.

NOTICE

When the carburetor has been modified for high altitude operation, the air/fuel mixture will be too lean for low altitude use. Operation at altitudes below 5,000 feet (1,500 meters) with a modified carburetor may cause the engine to overheat and result in serious engine damage. For use at low altitudes, have your servicing dealer return the carburetor to original factory specifications.

PRE-OPERATION CHECK

ENGINE OIL

Check the oil level **BEFORE EACH USE** with the generator on a level surface and the engine stopped.

Use 4-stroke motor oil that meets or exceeds the requirements for API service classification SJ or later (or equivalent). Always check the API SERVICE label on the oil container to be sure it includes the letter SJ or later (or equivalent).

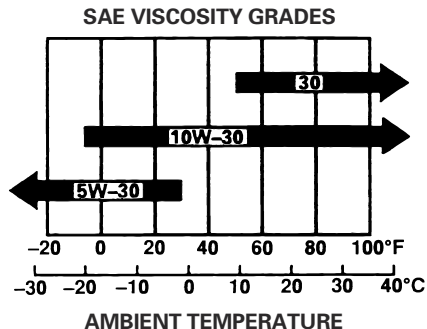

SAE 10W-30 is recommended for general, all-temperature use. Other viscosities shown in the chart may be used when the average temperature in your area is within the indicated range.

1. Place the generator on a level surface.
2. Loosen the cover screw and remove the maintenance cover.

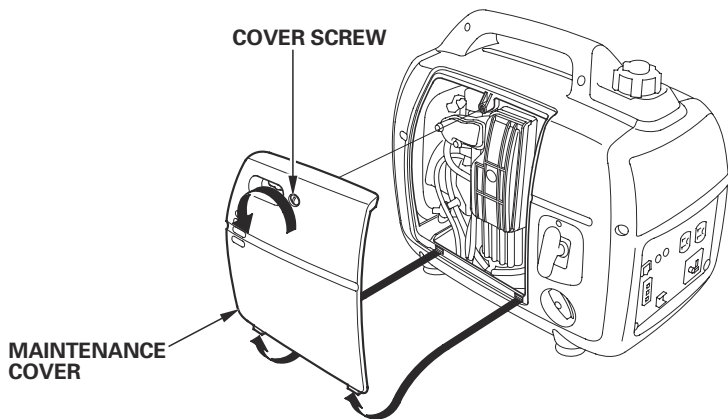

-
3. Remove the oil filler cap and wipe the dipstick clean.
 4. Check the oil level by inserting the dipstick into the filler neck without screwing it in.
 5. If the level is low, fill to the upper limit of the oil filler neck with the recommended oil.
 6. Reinstall the maintenance cover and tighten the cover screw securely.

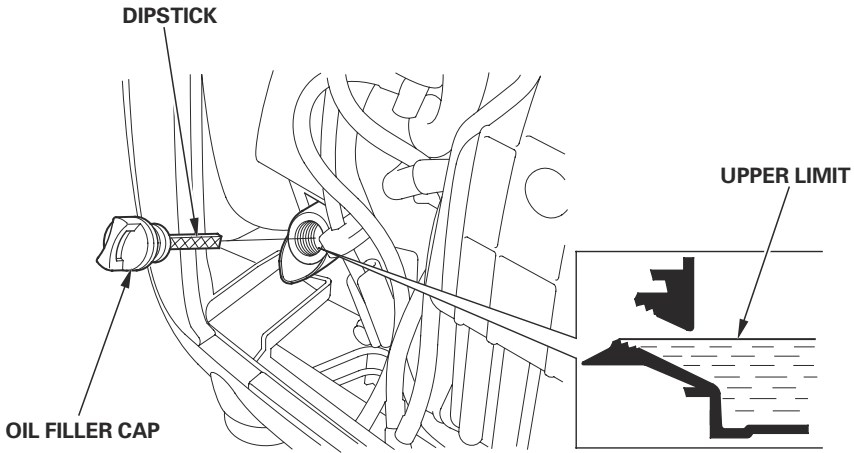

REFUELING

With the engine stopped, remove the fuel tank cap and check the fuel level. Refill the fuel tank if the fuel level is low. Refuel carefully to avoid spilling fuel. Do not fill above the upper limit mark.

▲WARNING

Gasoline is highly flammable and explosive.

You can be burned or seriously injured when handling fuel.

- **Stop the engine and keep heat, sparks, and flame away.**
- **Handle fuel only outdoors.**
- **Wipe up spills immediately.**

NOTICE

Fuel can damage paint and plastic. Be careful not to spill fuel when filling your fuel tank. Damage caused by spilled fuel is not covered under warranty.

NON-CALIFORNIA TYPE

FUEL TANK CAP

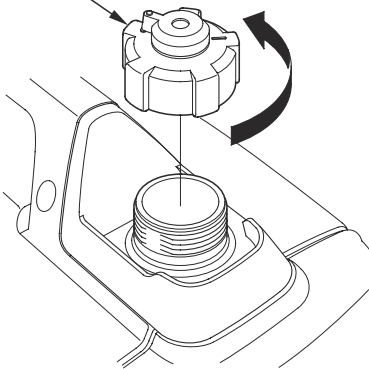

UPPER LIMIT MARK

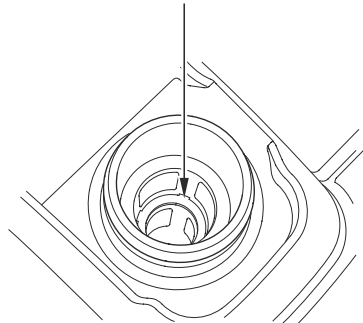

After refueling, reinstall the fuel tank cap securely.

CALIFORNIA TYPE

FUEL TANK CAP

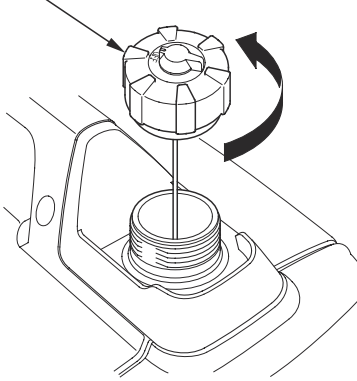

UPPER LIMIT MARK

TETHER

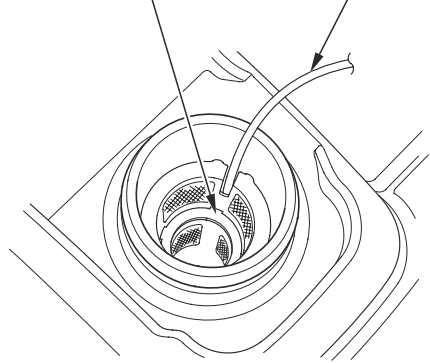

After refueling, tighten the fuel cap until it clicks.

FUEL RECOMMENDATIONS

This engine is certified to operate on regular unleaded gasoline with a pump octane rating of 86 or higher.

Never use stale or contaminated gasoline or an oil/gasoline mixture. Avoid getting dirt or water in the fuel tank.

You may use regular unleaded gasoline containing no more than 10% Ethanol (E10) or 5% Methanol by volume. In addition, Methanol must contain cosolvents and corrosion inhibitors.

Use of fuels with content of Ethanol or Methanol greater than shown above may cause starting and/or performance problems. It may also damage metal, rubber, and plastic parts of the fuel system.

Engine damage or performance problems that result from using a fuel with percentages of Ethanol or Methanol greater than shown above are not covered under warranty.

STARTING THE ENGINE

STARTING THE ENGINE

For your safety, avoid starting or operating the generator in an enclosed area such as a garage. Your generator's exhaust contains poisonous carbon monoxide gas that can collect rapidly in an enclosed area and cause illness or death.

▲WARNING

Carbon monoxide gas is toxic. Breathing it can cause unconsciousness and even kill you.

Avoid any enclosed areas, partially enclosed areas or activities that may expose you to carbon monoxide.

1. Perform *PRE-OPERATION CHECK* (see page 28).
2. Make sure that all appliances are disconnected from the AC receptacles.
3. Turn the fuel cap vent lever to the ON position.
4. To start a cold engine, move the choke lever to the CLOSED position. To restart a warm engine, leave the choke lever in the OPEN position.
5. Turn the engine switch to the ON position.
6. Pull the starter grip lightly until you feel resistance, then pull briskly.

NOTICE

Do not allow the starter grip to snap back against the engine. Return it gently to prevent damage to the starter or housing.

-
7. If the choke lever was moved to the CLOSED position to start the engine, gradually move it to the OPEN position as the engine warms up.
 8. If you wish to use the Eco-Throttle system, turn the Eco-Throttle switch to the ON position after the engine has warmed up for 2 or 3 minutes.
 9. Refer to the *AC OPERATION* (see page 20) or *DC OPERATION* (see page 24) for connecting loads to the generator.

STOPPING THE ENGINE

STOPPING THE ENGINE

To stop the engine in an emergency, simply turn the engine switch to the OFF position. Under normal conditions, use the following procedure.

1. Unplug appliances from the generator receptacles.
2. Turn the engine switch to the OFF position.
The fuel valve will automatically close.
3. Allow the engine to cool well, turn the vent lever to the OFF position.
4. If two generators were connected for parallel operation, disconnect the parallel operation kit after stopping the engines if you do not wish to resume parallel operation.

MAINTENANCE

THE IMPORTANCE OF MAINTENANCE

Good maintenance is essential for safe, economical, and trouble free operation. It will also help reduce air pollution.

▲WARNING

Improper maintenance, or failure to correct a problem before operation, can cause a malfunction in which you can be seriously hurt or killed.

Always follow the inspection and maintenance recommendations and schedules in this owner's manual.

To help you properly care for your generator, the following pages include a maintenance schedule, routine inspection procedures, and simple maintenance procedures using basic hand tools. Other service tasks that are more difficult, or require special tools, are best handled by professionals and are normally performed by a Honda technician or other qualified mechanic.

The maintenance schedule applies to normal operating conditions. If you operate your generator under severe conditions, such as sustained high-load or high-temperature operation, or use it in unusually wet or dusty conditions, consult your servicing dealer for recommendations applicable to your individual needs and use.

Remember that your servicing dealer knows your generator best and is fully equipped to maintain and repair it.

To ensure the best quality and reliability, use only new, genuine Honda parts or their equivalents for repair or replacement.

Maintenance, replacement, or repair of the emission control devices and systems may be performed by any engine repair establishment or individual, using parts that are "certified" to EPA standards.

MAINTENANCE SAFETY

Some of the most important safety precautions follow. However, we cannot warn you of every conceivable hazard that can arise in performing maintenance. Only you can decide whether or not you should perform a given task.

▲WARNING

Failure to properly follow maintenance instructions and precautions can cause you to be seriously hurt or killed.

Always follow the procedures and precautions in the owner's manual.

Safety Precautions

- Make sure the engine is off before you begin any maintenance or repairs. This will eliminate several potential hazards:
 - **Carbon monoxide poisoning from engine exhaust.**
Be sure there is adequate ventilation whenever you operate the engine.
 - **Burns from hot parts.**
Let the engine and exhaust system cool before touching.
 - **Injury from moving parts.**
Do not run the engine unless instructed to do so.
- Read the instructions before you begin, and make sure you have the tools and skills required.
- To reduce the possibility of fire or explosion, be careful when working around gasoline. Use only a nonflammable solvent, not gasoline, to clean parts. Keep cigarettes, sparks, and flames away from all fuel-related parts.

EMISSION CONTROL SYSTEM INFORMATION

Source of Emissions

The combustion process produces carbon monoxide, oxides of nitrogen, and hydrocarbons. Control of hydrocarbons and oxides of nitrogen are very important because, under certain conditions, they react to form photochemical smog when subjected to sunlight. Carbon monoxide does not react in the same way, but it is toxic.

Honda utilizes appropriate air/fuel ratios and other emissions control systems to reduce the emissions of carbon monoxide, oxides of nitrogen and hydrocarbons.

The U.S. and California Clean Air Acts

EPA and California regulations require all manufacturers to furnish written instructions describing the operation and maintenance of emission control systems.

The following instructions and procedures must be followed in order to keep the emissions from your Honda engine within the emission standards.

Tampering and Altering

Tampering with or altering the emission control system may increase emissions beyond the legal limit. Among those acts that constitute tampering are:

- Removal or alteration of any part of the intake, fuel, or exhaust systems.
- Altering or defeating the governor linkage or speed-adjusting mechanism to cause the engine to operate outside its design parameters.

Problems That May Affect Emissions

If you are aware of any of the following symptoms, have your engine inspected and repaired by your servicing dealer.

- Hard starting or stalling after starting.
- Rough idle.
- Misfiring or backfiring under load.
- Afterburning (backfiring).
- Black exhaust smoke or high fuel consumption.

Replacement Parts

The emission control systems on your Honda engine were designed, built, and certified to conform with EPA and California emission regulations (models certified for sale in California). We recommend the use of genuine Honda parts whenever you have maintenance done. These original-design replacement parts are manufactured to the same standards as the original parts, so you can be confident of their performance. The use of replacement parts that are not of the original design and quality may impair the effectiveness of your emission control system.

A manufacturer of an aftermarket part assumes the responsibility that the part will not adversely affect emission performance. The manufacturer or rebuilder of the part must certify that use of the part will not result in a failure of the engine to comply with emission regulations.

Maintenance

Follow the *maintenance schedule* on page 41. Remember that this schedule is based on the assumption that your machine will be used for its designed purpose. Sustained high-load or high-temperature operation, or use in unusually wet or dusty conditions, will require more frequent service.

AIR INDEX (Models certified for sale in California)

An Air Index Information hang tag/label is applied to engines certified to an emission durability time period in accordance with the requirements of the California Air Resources Board.

The bar graph is intended to provide you, our customer, the ability to compare the emissions performance of available engines. The lower the Air Index, the less pollution.

The durability description is intended to provide you with information relating to the engine's emission durability period. The descriptive term indicates the useful life period for the engine's emission control system. See your *Emission Control System Warranty* for additional information.

Descriptive Term	Applicable to Emission Durability Period
Moderate	50 hours (0–80 cc, inclusive) 125 hours (greater than 80 cc)
Intermediate	125 hours (0–80 cc, inclusive) 250 hours (greater than 80 cc)
Extended	300 hours (0–80 cc, inclusive) 500 hours (greater than 80 cc) 1,000 hours (225 cc and greater)

The Air Index Information hang tag must remain on the generator until it is sold. Remove the hang tag before operating the generator.

MAINTENANCE SCHEDULE

REGULAR SERVICE PERIOD (3) ITEM Perform at every indicated month or operating hour interval, whichever comes first.		Each use	First month or 20 hrs.	Every 3 months or 50 hrs.	Every 6 months or 100 hrs.	Every year or 200 hrs.
Engine oil	Check level	○				
	Change		○		○	
Air cleaner	Check	○				
	Clean			○(1)		
Spark plug	Check-adjust				○	
	Replace					○
Spark arrester	Clean				○	
Valve clearance	Check-readjust					○(2)
Combustion chamber	Clean	After every 300 hrs (2)				
Fuel tank and filter	Clean				○(2)	
Fuel line	Check	Every 2 years (Replace if necessary) (2)				

(1) Service more frequently when used in dusty areas.

(2) These items should be serviced by an authorized Honda generator dealer, unless the owner has the proper tools and is mechanically proficient. See the Honda Shop Manual.

(3) For commercial use, log hours of operation to determine proper maintenance intervals.

Failure to follow this maintenance schedule could result in non-warrantable failures.

ENGINE OIL CHANGE

Drain the used oil while the engine is warm. Warm oil drains quickly and completely.

1. Turn the engine switch and vent lever to the OFF position to reduce the possibility of fuel leakage.
2. Loosen the cover screw and remove the maintenance cover (see page 28).
3. Place a suitable container next to the engine to catch the used oil.
4. Remove the oil filler cap/dipstick, and drain the oil into the container by tipping the engine toward the oil filler neck.
5. With the engine in a level position, fill to the upper limit of the oil filler neck with the recommended oil (see page 28).
6. Reinstall the oil filler cap/dipstick securely.
7. Reinstall the maintenance cover and tighten the cover screw securely.

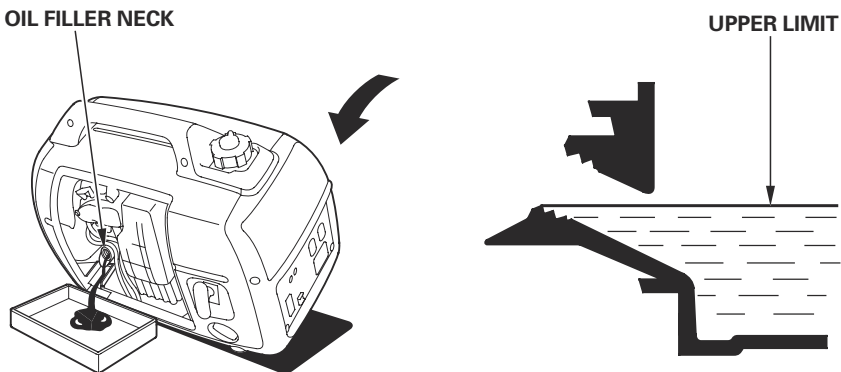

Wash your hands with soap and water after handling used oil.

NOTICE

Improper disposal of engine oil can be harmful to the environment. If you change your own oil, please dispose of it properly. Put it in a sealed container, and take it to a recycling center. Do not discard it in a trash bin, dump it on the ground, or pour it down a drain.

AIR CLEANER SERVICE

A dirty air cleaner will restrict air flow to the carburetor. To prevent carburetor malfunction, service the air cleaner regularly. Service more frequently when operating the generator in extremely dusty areas.

▲WARNING

Using gasoline or flammable solvent to clean the air filter can cause a fire or explosion. Use only soapy water or nonflammable solvent.

NOTICE

Operating the engine without an air filter, or with a damaged air filter, will allow dirt to enter the engine, causing rapid engine wear. This type of damage is not covered by the Distributor's Limited Warranty.

1. Loosen the cover screw and remove the maintenance cover.
2. Loosen the air cleaner cover screw, and remove the air cleaner cover.
3. Wash the main and outer filter in a solution of household detergent and warm water, then rinse thoroughly, or wash in nonflammable or high flash point solvent. Allow the air filters to dry thoroughly.
4. Soak the main and outer filter in clean engine oil and squeeze out the excess oil. The engine will smoke during initial startup if too much oil is left in the air filters.

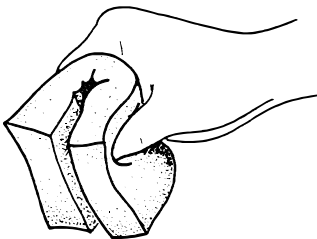
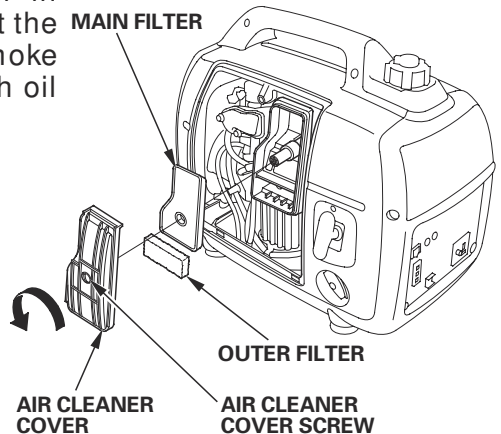
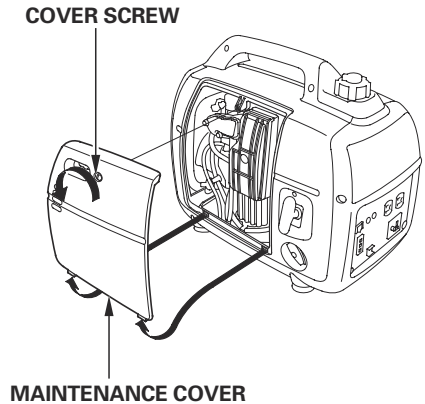

5. Reinstall the air filters.

6. Make sure that the rubber seal is set in the groove of the air cleaner cover.

7. Reinstall the air cleaner cover, and tighten the air cleaner cover screw.

8. Reinstall the maintenance cover, and tighten the cover screw securely.

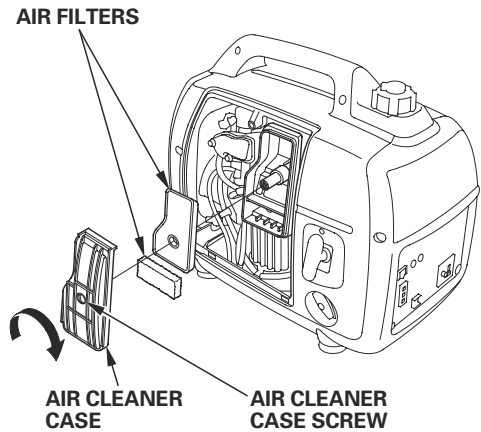
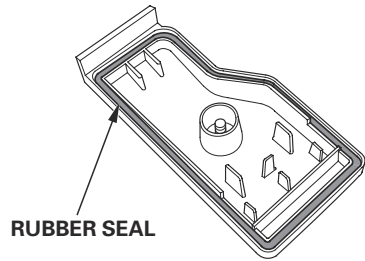

SPARK PLUG SERVICE

In order to service the spark plug, you will need a spark plug wrench (commercially available).

Recommended spark plug: CR5HSB (NGK)

To ensure proper engine operation, the spark plug must be properly gapped and free of deposits.

NOTICE

An incorrect spark plug can cause engine damage.

If the engine has been running, allow it to cool before servicing the spark plug.

1. Remove the spark plug maintenance cover.

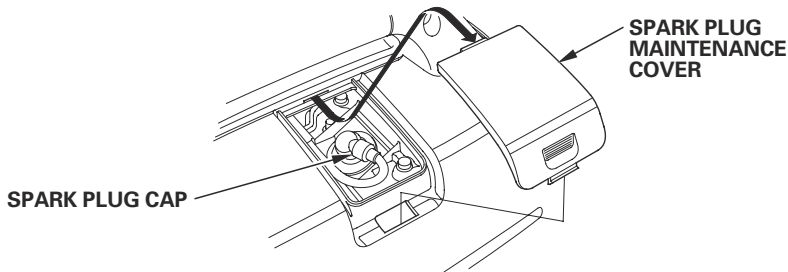

2. Remove the spark plug cap.
3. Clean any dirt from around the spark plug base.
4. Use a spark plug wrench to remove the spark plug.

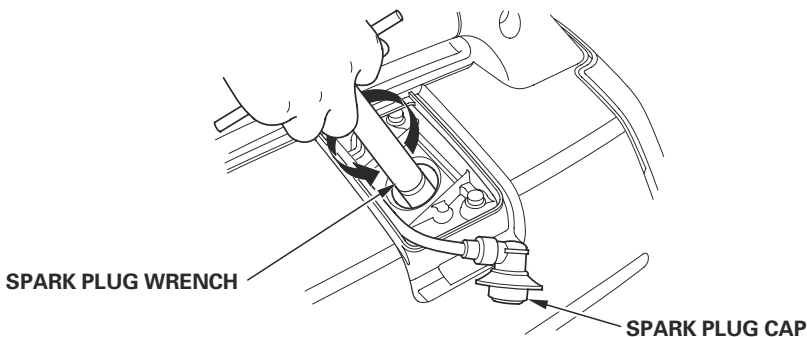

-
5. Visually inspect the spark plug. Replace it if the electrodes are worn or if the insulator is cracked, chipped, or fouled.
 6. Measure the spark plug electrode gap with a wire-type feeler gauge. Correct the gap, if necessary, by carefully bending the side electrode. The gap should be:
0.024–0.028 in (0.60–0.70 mm)

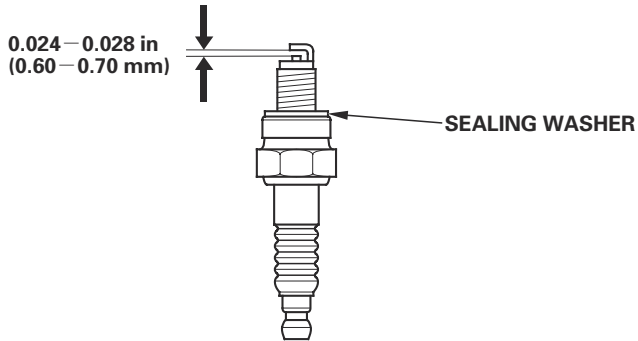

7. Check that the spark plug sealing washer is in good condition, and thread the spark plug in by hand to prevent cross-threading.
8. After the spark plug is seated, tighten with a spark plug wrench to compress the washer.

If installing a new spark plug, tighten 1/2 turn after the spark plug seats to compress the washer. If reinstalling a used spark plug, tighten 1/8–1/4 turn after the spark plug seats to compress the washer.

NOTICE

A loose spark plug can overheat and damage the engine. Overtightening the spark plug can damage the threads in the cylinder head.

9. Reinstall the spark plug cap on the spark plug securely.
10. Reinstall the spark plug maintenance cover.

SPARK ARRESTER MAINTENANCE

If the generator has been running, the muffler will be very hot. Allow it to cool before proceeding.

The spark arrester must be serviced every 100 hours to maintain its efficiency.

Clean the spark arrester as follows:

1. Remove the four 6 mm screws, and remove the muffler protector.

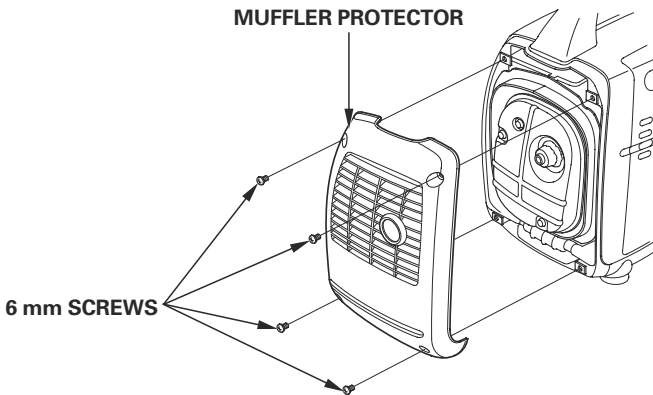

2. Remove the three 6 mm bolts, and remove the muffler, the spark arrester, and the muffler gasket.

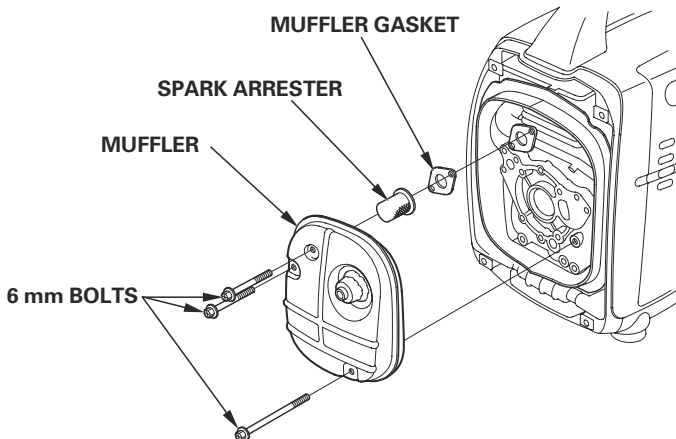

-
3. Use a brush to remove carbon deposits from the spark arrester screen.



4. Inspect the screen for breaks or tears and replace it if necessary.
5. Check the muffler gasket; replace if damaged. Reinstall the muffler gasket, the spark arrester, the muffler, and the muffler protector in the reverse order of removal.

TRANSPORTING/STORAGE

TRANSPORTING

NOTICE

Do not lay the generator on its side when moving, storing, or operating it. Oil may leak and damage the engine or your property.

If the generator has been used, allow it cool for at least 15 minutes before loading the generator on the transport vehicle. A hot engine and exhaust system can burn you and can ignite some material.

To prevent fuel spillage when transporting, the generator should be secured upright in its normal operating position, with the engine switch OFF and the fuel tank cap vent lever turned fully counterclockwise to the "OFF" position.

Take care not to drop or strike the generator when transporting. Do not place heavy objects on the generator.

STORAGE

Before storing the unit for an extended period:

1. Be sure the storage area is free of excessive humidity and dust.
2. Service according to the table below:

STORAGE TIME	RECOMMENDED SERVICE PROCEDURE TO PREVENT HARD STARTING
Less than 1 month	No preparation required
1 to 2 months	Fill with fresh gasoline and add gasoline stabilizer *. Run the engine for 10 minutes to use up the non-treated gasoline.
2 to 6 months	Fill with fresh gasoline and add gasoline stabilizer *. Run the engine for 10 minutes to use up the non-treated gasoline. Or drain the gasoline (page 52).
6 months or more	Drain the gasoline (page 52). Remove the spark plug. Put a tablespoon of engine oil into the cylinder. Turn the engine slowly with the starter grip to distribute the oil. Reinstall the spark plug. Change the engine oil (page 42). After removal from storage, fill with fresh gasoline before starting.
* Use gasoline stabilizers that are formulated to extend storage life. Follow the instructions included with the gasoline stabilizer. Contact your authorized Honda generator dealer for gasoline stabilizer recommendations.	

Storage Procedure

1. Drain the gasoline.
 - a. Unscrew the fuel tank cap, remove the debris screen, and empty the fuel tank into an approved gasoline container using a commercially available hand siphon. Reinstall the debris screen and the fuel tank cap.
 - b. Loosen the cover screw and remove the maintenance cover.
 - c. Loosen the carburetor drain screw.
 - d. Drain the gasoline from the carburetor into a suitable container.
 - e. Remove the spark plug maintenance cover.
 - f. Remove the spark plug cap.
 - g. Turn the engine switch to the ON position.
 - h. Pull the starter grip 3 to 4 times to drain the gasoline from the fuel pump into a suitable container.
 - i. Turn the engine switch to the OFF position.
 - j. Tighten the carburetor drain screw.

▲WARNING

Gasoline is highly flammable and explosive.

You can be burned or seriously injured when handling fuel.

- **Keep heat, sparks, and flame away.**
- **Handle fuel only outdoors.**
- **Wipe up spills immediately.**

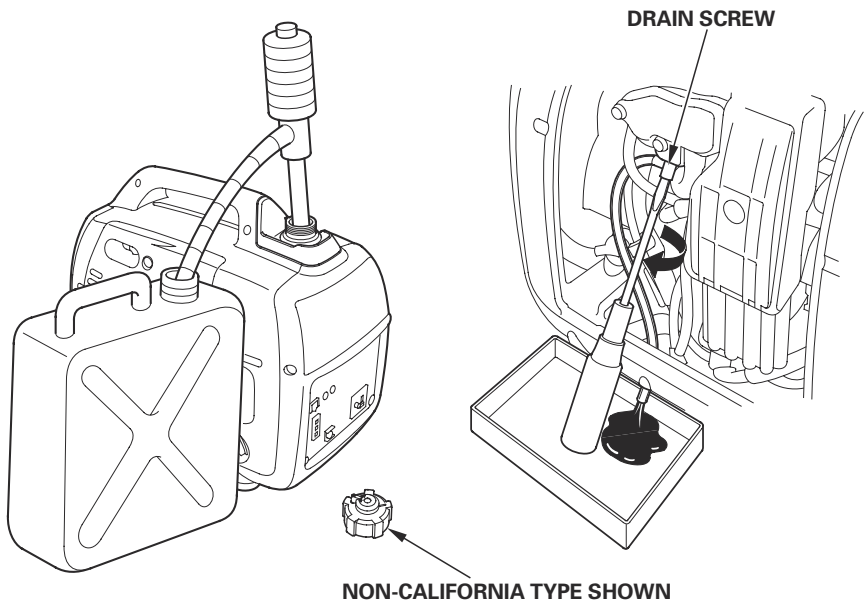

-
2. Change the engine oil (see page 42).
 3. Remove the spark plug, and pour about a tablespoon of clean engine oil into the cylinder. Crank the engine several revolutions to distribute the oil, then reinstall the spark plug.
 4. Reinstall the spark plug cap on the spark plug securely.
 5. Reinstall the spark plug maintenance cover.
 6. Reinstall the maintenance cover and tighten the cover screw securely.
 7. Pull the starter grip slowly until you feel resistance, then return the starter grip gently. This closes the valves so moisture cannot enter.

TROUBLESHOOTING

When the engine will not start:

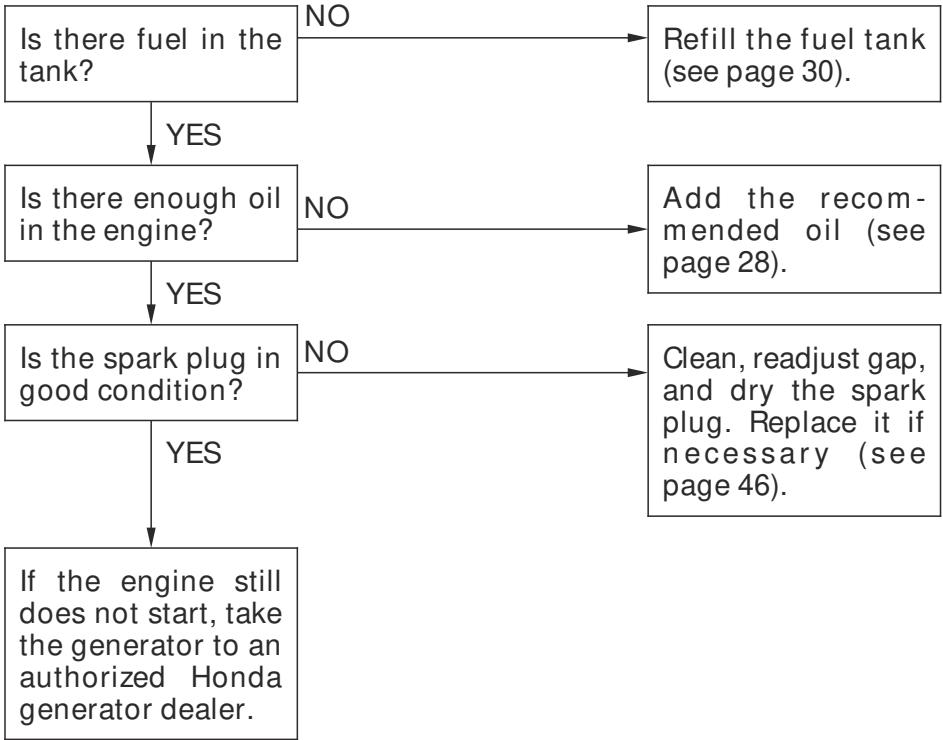

Appliance does not operate:

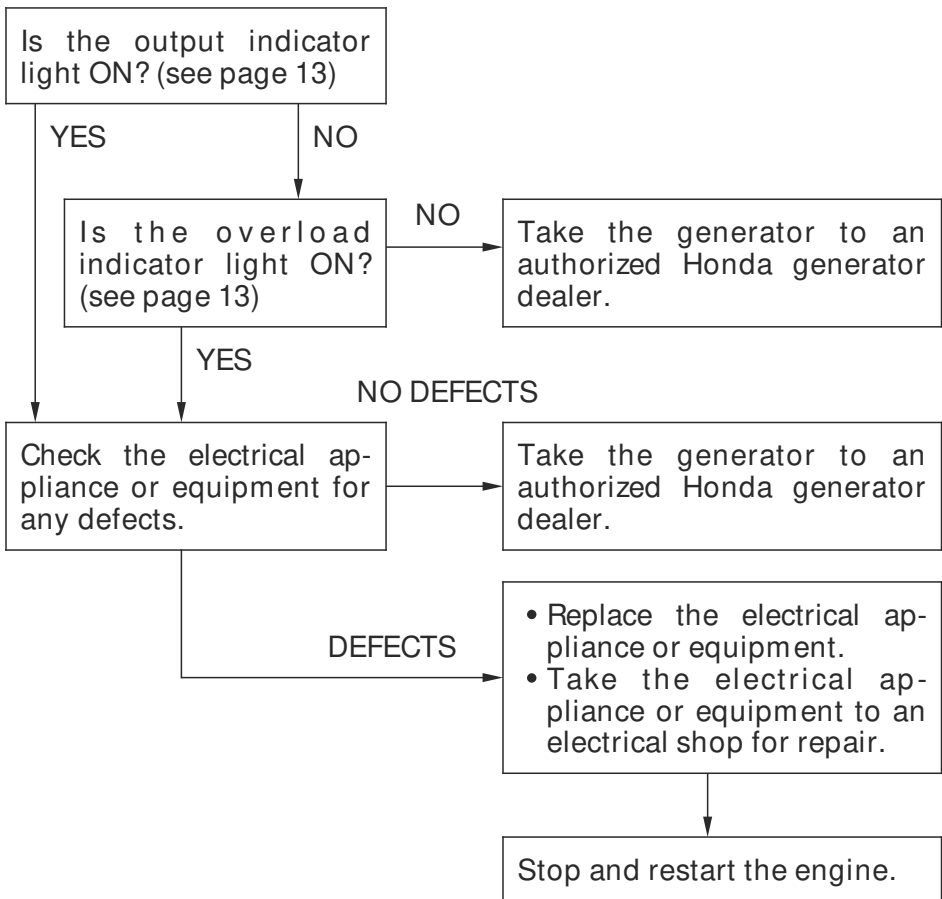

No electricity at the DC receptacle:

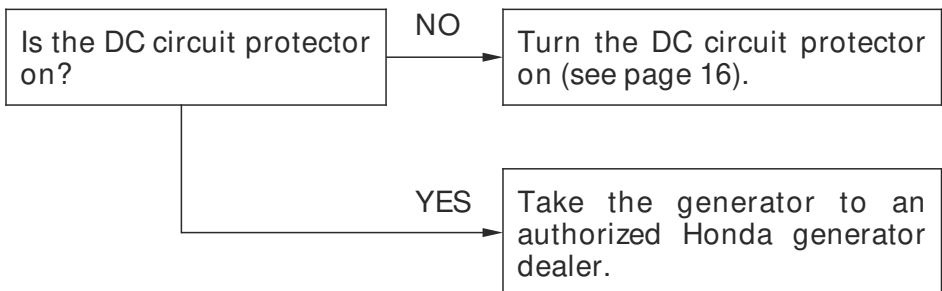

WIRING DIAGRAM

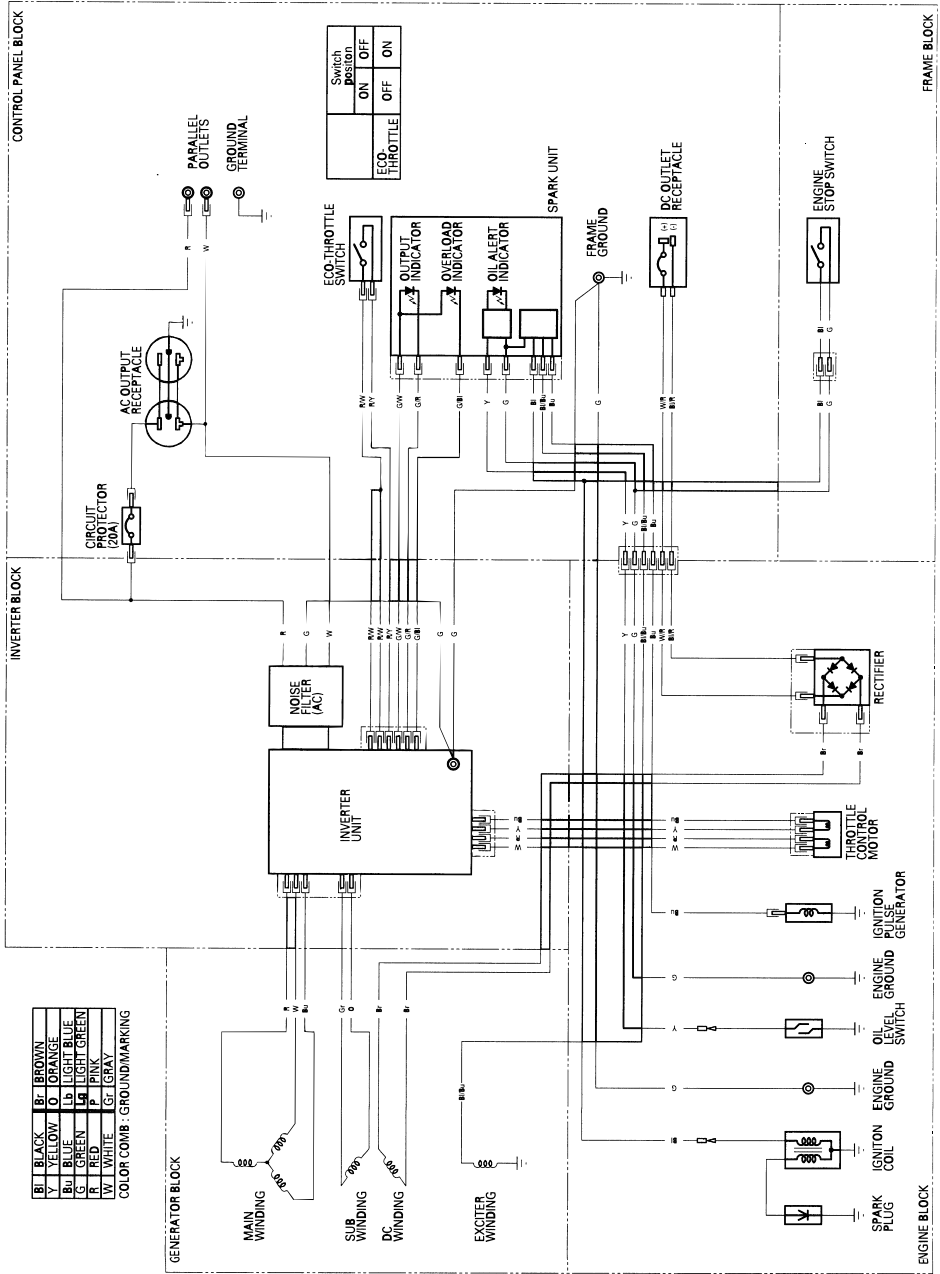

INITIAL USE INSTRUCTIONS

ADDING ENGINE OIL

The generator is shipped **WITHOUT OIL** in the engine.

1. Place the generator on a level surface.
2. Loosen the cover screw and remove the maintenance cover.

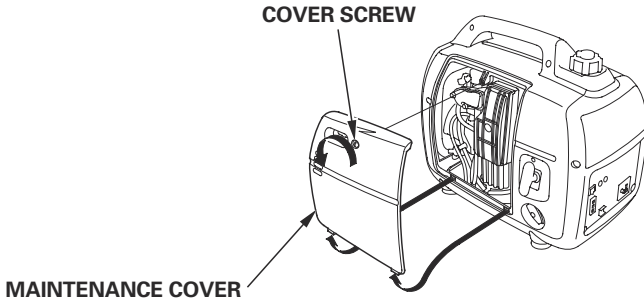

3. With the generator in a level position, remove the oil filler cap/dipstick.
4. Add enough SAE 10W-30 API service classification SJ or later (or equivalent) oil to bring the oil level to the upper limit of the oil filler neck. SAE 10W-30 oil is recommended for general use; for additional recommendations, see page 28.

Do not overfill the engine with oil. If the engine is overfilled, the excess oil may be transferred to the air cleaner housing and air filter.

5. Screw in the oil filler cap/dipstick securely.

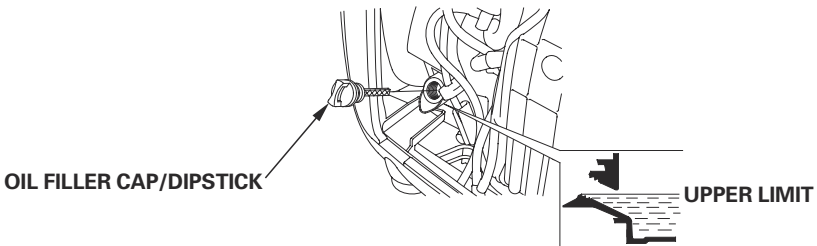

6. Reinstall the maintenance cover.

ADDING FUEL

This engine is certified to operate on unleaded gasoline with a pump octane rating of 86 or higher.

Never use stale or contaminated gasoline or an oil/gasoline mixture. Avoid getting dirt or water in the fuel tank.

If the fuel level is low, refuel in a well-ventilated area with the engine stopped. If the engine has been running, allow it to cool first. Never refuel the engine inside a building where gasoline fumes can reach flames or sparks.

You may use regular unleaded gasoline containing no more than 10% Ethanol (E10) or 5% Methanol by volume. In addition, Methanol must contain cosolvents and corrosion inhibitors.

Use of fuels with content of Ethanol or Methanol greater than shown above may cause starting and/or performance problems. It may also damage metal, rubber, and plastic parts of the fuel system.

Engine damage or performance problems that result from using a fuel with percentages of Ethanol or Methanol greater than shown above are not covered under warranty.

With the engine stopped, add fuel to the generator in a well-ventilated area.

▲WARNING

Gasoline is highly flammable and explosive.

You can be burned or seriously injured when handling fuel.

- **Stop the engine and keep heat, sparks, and flame away.**
- **Handle fuel only outdoors.**
- **Wipe up spills immediately.**

1. Remove the fuel tank cap.

NON-CALIFORNIA TYPE

FUEL TANK CAP

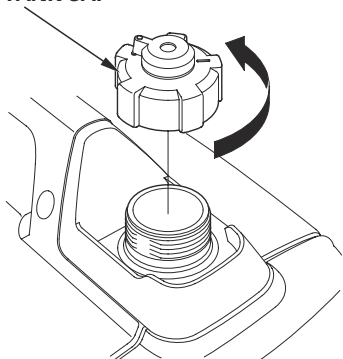

CALIFORNIA TYPE

FUEL TANK CAP

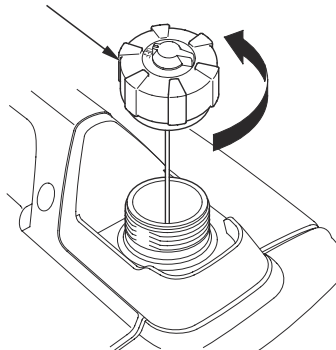

2. Fuel carefully to avoid spilling fuel.

Do not fill the fuel tank above the upper limit mark on the fuel strainer.

NON-CALIFORNIA TYPE

UPPER LIMIT MARK

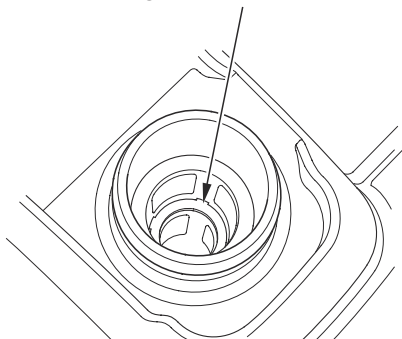

CALIFORNIA TYPE

UPPER LIMIT MARK

TETHER

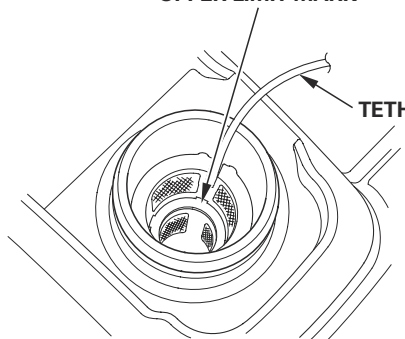

NOTICE

Fuel can damage paint and plastic. Be careful not to spill fuel when filling your fuel tank. Damage caused by spilled fuel is not covered under warranty.

-
3. After refueling, tighten the fuel cap securely (Non-California type).
After refueling, tighten the fuel cap until it clicks (California type).
Keep the vent OFF for storage or transport, and ON to run the generator.

NON-CALIFORNIA TYPE

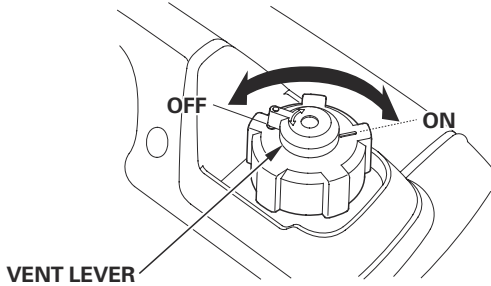

CALIFORNIA TYPE

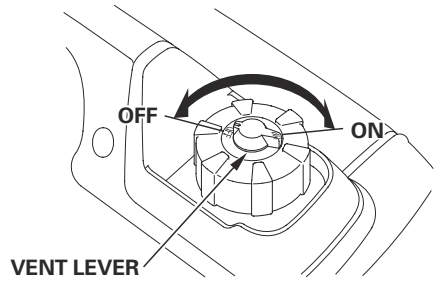

Move the generator at least 10 feet (3 meters) away from the fueling source and site before starting the engine.

After initial fueling (or anytime the generator is run completely out of fuel), starting the engine may require additional pulls of the starter grip. This generator utilizes a vacuum operated fuel pump and may require additional pulls to draw fuel into the carburetor.

BEFORE OPERATION

Before using the generator, all generator operators must read the following chapters and sections:

- **GENERATOR SAFETY** (pages 5 – 8)
- **CONTROLS** (pages 11 – 16)
- **GENERATOR USE** (pages 17 – 27)
- **PRE-OPERATION CHECK** (pages 28 – 32)
- **STARTING THE ENGINE** (pages 33 – 34)
- **STOPPING THE ENGINE** (page 35)
- **MAINTENANCE SCHEDULE** (page 41)

SPECIFICATIONS

Dimensions

Model	EU2000i
Description code	EAAJ
Length	20.2 in (512 mm)
Width	11.4 in (290 mm)
Height	16.7 in (425 mm)
Dry weight	45.9 lbs (20.8 kg)

Engine

Model	GX100
Engine type	4-stroke, overhead camshaft, single cylinder
Displacement [Bore × Stroke]	6.01 cu-in (98.5 cm ³) [2.20 × 1.57 in (56.0 × 40.0 mm)]
Compression ratio	8.5: 1
Engine speed	4,300–5,000 rpm (with Eco-Throttle switch OFF)
Cooling system	Forced air
Ignition system	Full transistor
Oil capacity	0.42 US qt (0.40 ℓ)
Fuel tank capacity	0.95 US gal (3.6 ℓ)
Spark plug	CR5HSB (NGK)

Generator

Model	EU2000i	
Type	California type (AC type) Non-California type (AN type)	
AC output	Rated voltage	120 V
	Rated frequency	60 Hz
	Rated current	13.3 A
	Rated output	1,600 VA
	Maximum output	2,000 VA
DC output	Only for charging 12V automotive batteries. Maximum charging output= 8A	

Tuneup

ITEM	SPECIFICATION	MAINTENANCE
Spark plug gap	0.024 – 0.028 in (0.60–0.70 mm)	Refer to page 46
Valve clearance (cold)	IN: 0.15±0.04 mm EX: 0.20±0.04 mm	See your authorized Honda dealer.
Other specifications	No other adjustments needed.	

Specifications are subject to change without notice.

TECHNICAL & CONSUMER INFORMATION

Dealer Locator Information

To find an authorized Honda Servicing Dealer anywhere in the United States:

Visit our website:
www.hondapowerequipment.com

Customer Service Information

Servicing dealership personnel are trained professionals. They should be able to answer most questions you may have. If you encounter a problem that your dealer does not solve to your satisfaction, please discuss it with the dealership's management. The Service Manager or General Manager can help. Almost all problems are solved in this way.

If you are dissatisfied with the decision made by the dealership's management, contact the Honda Power Equipment Customer Relations Office. You can write to:

American Honda Motor Co., Inc.
Power Equipment Division
Customer Relations Office
4900 Marconi Drive
Alpharetta, Georgia 30005-8847

Or telephone: (770) 497-6400 8:30 am to 7:00 pm ET

When you write or call, please give us this information:

- Model and serial number (see page 10)
- Name of dealer who sold the generator to you
- Name and address of dealer who services your generator
- Date of purchase
- Your name, address, and telephone number
- A detailed description of the problem

Honda Publications

Shop Manual

This manual covers complete maintenance and overhaul procedures. It is intended to be used by a skilled technician.

Available through your Honda dealer or through Helm Inc. at 1 888-292-5395 or visit www.hondapowerequipment.com

Parts Catalog

This manual provides complete, illustrated parts lists. Available through your Honda dealer.

Accessories Catalog

Your authorized Honda power equipment dealer offers a wide selection of accessories (optional equipment) to make your generator even more useful.

Visit www.hondapowerequipment.com and click on Generators and Welders to see the entire catalog of accessories.

Especially popular accessories include:

- Covers
- Spill-proof gasoline cans
- Battery charging cords
- Parallel connection cables
- Transfer switches and kits
- Plugs and connectors

Distributor's Limited Warranty

PRODUCTS COVERED BY THIS WARRANTY	LENGTH OF WARRANTY (from date of original retail purchase)	
	EU series generators	Noncommercial/ Nonrental
Engine	24 months	24 months
Generator Electrical and Frame Components	24 months	12 months
Parts & Accessories.	See your authorized Honda servicing dealer for details	

To Qualify for this Warranty:

The product must be purchased in the United States, Puerto Rico, or the U.S. Virgin Islands from American Honda or a dealer authorized by American Honda to sell those products. This warranty applies to the first retail purchaser and each subsequent owner during the applicable warranty time period.

What American Honda will Repair or Replace Under Warranty:

American Honda will repair or replace, at its option, any part that is proven to be defective in material or workmanship under normal use during the applicable warranty time period. Warranty repairs and replacements will be made without charge for parts or labor. Anything replaced under warranty becomes the property of American Honda Motor Company, Inc. All parts replaced under warranty will be considered as part of the original product and any warranty on those parts will expire coincident with the original product warranty.

To Obtain Warranty Service:

You must take the Honda generator and proof of original retail purchase date, at your expense, to any Honda Power Equipment dealer in the United States, Puerto Rico, or the U.S. Virgin Islands who is authorized to service that product, during the dealer's normal business hours. If you are unable to obtain warranty service, or are dissatisfied with the warranty service you receive, take the following steps: First, contact the owner of the dealership involved; normally this should resolve the problem. However, if you should require further assistance, write or call the Power Equipment Customer Relations Department of American Honda Motor Co., Inc. Refer to page 62 for contact information.

Exclusions:

This warranty does not extend to parts affected or damaged by accident and/or collision, normal wear, fuel contamination, use in an application for which the product was not designed, or any other misuse, neglect, incorporation or use of unsuitable attachments or parts, unauthorized alteration, or any causes other than defects in material or workmanship of the product.

Disclaimer of Consequential Damage and Limitation of Implied Warranties:

American Honda disclaims any responsibility for loss of time or use of the product, transportation, commercial loss, or any other incidental or consequential damage. Any implied warranties are limited to the duration of this written limited warranty. Some states do not allow limitations on how long an implied warranty lasts and/or do not allow the exclusion or limitation of incidental or consequential damages, so the above exclusions and limitations may not apply to you. This warranty gives you specific legal rights, and you may also have other rights which vary from state to state.

Emission Control System Warranty

Your new Honda Power Equipment engine complies with the U.S. EPA, Environment Canada and State of California emission regulations. American Honda Motor Co., Inc. provides the emission warranty coverage for engines in the United States, and its territories. Honda Canada Inc. provides the emission warranty for engines in the 13 provinces and territories of Canada. In the remainder of this Emission Control System Warranty, American Honda Motor Company Inc. and Honda Canada Inc. will be referred to as Honda.

Your Warranty Rights And Obligations:***California***

The California Air Resources Board and Honda are pleased to explain the emission control system warranty on your Honda Power Equipment engine. In California, new spark-ignited small off-road equipment engines must be designed, built and equipped to meet the State's stringent anti-smog standards.

Other States, U.S. territories and Canada

In other areas of the United States and in Canada, your engine must be designed, built, and equipped to meet the U.S. EPA and Environment Canada emission standards for spark-ignited engines at or below 19 kilowatts.

All of the United States and Canada

Honda must warrant the emission control system on your power equipment engine for the period of time listed below, provided there has been no abuse, neglect or improper maintenance of your power equipment engine. Where a warrantable condition exists, Honda will repair your power equipment engine at no cost to you including diagnosis, parts and labor.

Your emission control system may include such parts as the carburetor or fuel injection system, the ignition system, and catalytic converter. Also included may be hoses, connectors and other emission-related assemblies.

Manufacturer's Warranty Coverage:

The 1995 and later power equipment engines are warranted for two years. If any emission related part on your engine is defective, the part will be repaired or replaced by Honda.

Owner's Warranty Responsibility:

As the power equipment engine owner, you are responsible for the performance of the required maintenance listed in your owner's manual. Honda recommends that you retain all receipts covering maintenance on your power equipment engine, but Honda cannot deny warranty coverage solely for the lack of receipts or for your failure to ensure the performance of all scheduled maintenance.

As the power equipment engine owner, you should however be aware Honda may deny you warranty coverage if your power equipment engine or a part has failed due to abuse, neglect, improper maintenance, or unapproved modifications.

You are responsible for presenting your power equipment engine to a Honda Power Equipment dealer as soon as a problem exists. The warranty repairs should be completed in a reasonable amount of time, not to exceed 30 days.

If you have any questions regarding your warranty rights and responsibilities, you should contact the Honda Office in your region:

American Honda Motor Co., Inc.
Power Equipment Customer
Relations
4900 Marconi Drive
Alpharetta, Georgia 30005-8847
Telephone: (770) 497-6400

Honda Canada Inc.
Power Equipment Customer
Relations
or
715 Milner Avenue
Toronto, ON M1B 2K8
Telephone: (888) 946-6329

Warranty Coverage:

Honda power equipment engines manufactured after January 1, 1995 and sold in the State of California, U.S. EPA certified engines manufactured on or after September 1, 1996 and sold in all of the United States, and Canadian certified engines manufactured on or after January 1, 2005 are covered by this warranty for a period of two years from the date of delivery to the original retail purchaser. This warranty is transferable to each subsequent purchaser for the duration of the warranty period.

Warranty repairs will be made without charge for diagnosis, parts or labor. All defective parts replaced under this warranty become the property of Honda. Warranted parts are listed under Emission Control System Warranty Parts on page 69. Normal maintenance items, such as spark plugs and filters, that are on the warranted parts list are warranted up to their required replacement interval only.

Honda is also liable for damages to other engine components caused by a failure of any warranted part during the warranty period.

Only Honda approved replacement parts may be used in the performance of any warranty repairs and must be provided without charge to the owner. The use of replacement parts not equivalent to the original parts may impair the effectiveness of your engine emission control system. If such a replacement part is used in the repair or maintenance of your engine, and an authorized Honda dealer determines it is defective or causes a failure of a warranted part, your claim for repair of your engine may be denied. If the part in question is not related to the reason your engine requires repair, your claim will not be denied.

To Obtain Warranty Service:

You must take your Honda Power Equipment engine or the product on which it is installed, along with your sales registration card or other proof of original purchase date, at your expense, to any Honda Power Equipment dealer who is authorized by Honda to sell and service that Honda product during his normal business hours. Claims for repair or adjustment found to be caused solely by defects in material or workmanship will not be denied because the engine was not properly maintained and used.

If you are unable to obtain warranty service, or are dissatisfied with the warranty service you received, contact the owner of the dealership involved. Normally this should resolve your problem. However, if you require further assistance, write or call the Honda Power Equipment Customer Relations Department in your region.

Exclusions:

Failures other than those resulting from defects in material or workmanship are not covered by this warranty. This warranty does not extend to emission control systems or parts which are affected or damaged by owner abuse, neglect, improper maintenance, misuse, misfueling, improper storage, accident and/or collision, the incorporation of, or any use of, any add-on or modified parts, unsuitable attachments, or the unauthorized alteration of any part.

This warranty does not cover replacement of expendable maintenance items made in connection with required maintenance services after the item's first scheduled replacement as listed in the maintenance section of the product owner's manual, such as: spark plugs and filters.

Disclaimer of Consequential Damage and Limitation of Implied Warranties:
 American Honda Motor Co., Inc. and Honda Canada Inc. disclaim any responsibility for incidental or consequential damages such as loss of time or the use of the power equipment, or any commercial loss due to the failure of the equipment; and any implied warranties are limited to the duration of this written warranty. This warranty is applicable only where the California, U.S. EPA or environment Canada emission control system warranty regulation is in effect.

Emission Control System Warranty Parts:

SYSTEMS COVERED BY THIS WARRANTY:	PARTS DESCRIPTION:
Fuel Metering	Carburetor assembly, (includes starting enrichment system), Engine temperature sensor, Engine control module, Fuel regulator, Intake manifold
Evaporative	Fuel tank, Fuel cap, Fuel hoses, Vapor hoses, Carbon canister, Canister mounting brackets, Fuel strainer, Fuel cock, Fuel pump, Fuel hose joint, Seal cap, Canister purge hose joint
Exhaust	Catalyst, Exhaust manifold
Air Induction	Air filter housing, Air filter element *, Crankcase breather tube
Ignition	Flywheel magneto, Ignition pulse generator, Crankshaft position sensor, Power coil, Ignition coil assembly, Ignition control module, Spark plug cap, Spark plug *
Miscellaneous Parts	Tubing, fittings, seals, gaskets, and clamps associated with these listed systems.

Note: This list applies to parts supplied by Honda and does not cover parts supplied by the equipment manufacturer. Please see the original equipment manufacturer's emissions warranty for non-Honda parts.

* Covered up to the first required replacement only.
 See the Maintenance Schedule.

INDEX

COMPONENT IDENTIFICATION	9
CONTENTS	3
CONTROLS	11
AC Circuit Protector	16
Choke Lever	12
DC Circuit Protector	16
DC Receptacle	16
Eco-Throttle System	15
Engine Switch	11
Fuel Tank Cap Vent Lever	12
Ground Terminal	14
Oil Alert® System	14
Output Indicator Light	13
Overload Indicator Light	13
Parallel Operation Outlets	15
Starter Grip	11
GENERATOR SAFETY	5
Important Safety Information	7
Safety Label Locations	5
GENERATOR USE	17
AC Applications	19
AC Operation	20
AC Parallel Operation	23
AC Parallel Operation Applications	21
Connections to a Building Electrical System	17
Connecting the battery charging cable (optional equipment)	24
DC Operation	24
Disconnecting the battery charging cable	25
Eco-Throttle Switch	26
Ground System	17
High Altitude Operation	27
Special Requirement	18
INITIAL USE INSTRUCTIONS	57
Adding Engine Oil	57
Adding Fuel	58

MAINTENANCE	36
Air Cleaner Service	44
Air Index	40
Emission Control System Information	38
Engine Oil Change	42
Importance of Maintenance	36
Maintenance Safety	37
Maintenance Schedule	41
Spark Arrester Maintenance	48
Spark Plug Service	46
PRE-OPERATION CHECK	28
Engine Oil	28
Fuel Recommendations	32
Refueling	30
SPECIFICATIONS	61
STARTING THE ENGINE	33
STOPPING THE ENGINE	35
TECHNICAL & CONSUMER INFORMATION	62
Customer Service Information	62
Distributor's Limited Warranty	64
Emission Control System Warranty	65
TRANSPORTING/STORAGE	50
Storage	51
Storage procedure	52
Transporting	50
TROUBLESHOOTING	54
WIRING DIAGRAM	56

MEMO

HONDA

The Power of Dreams

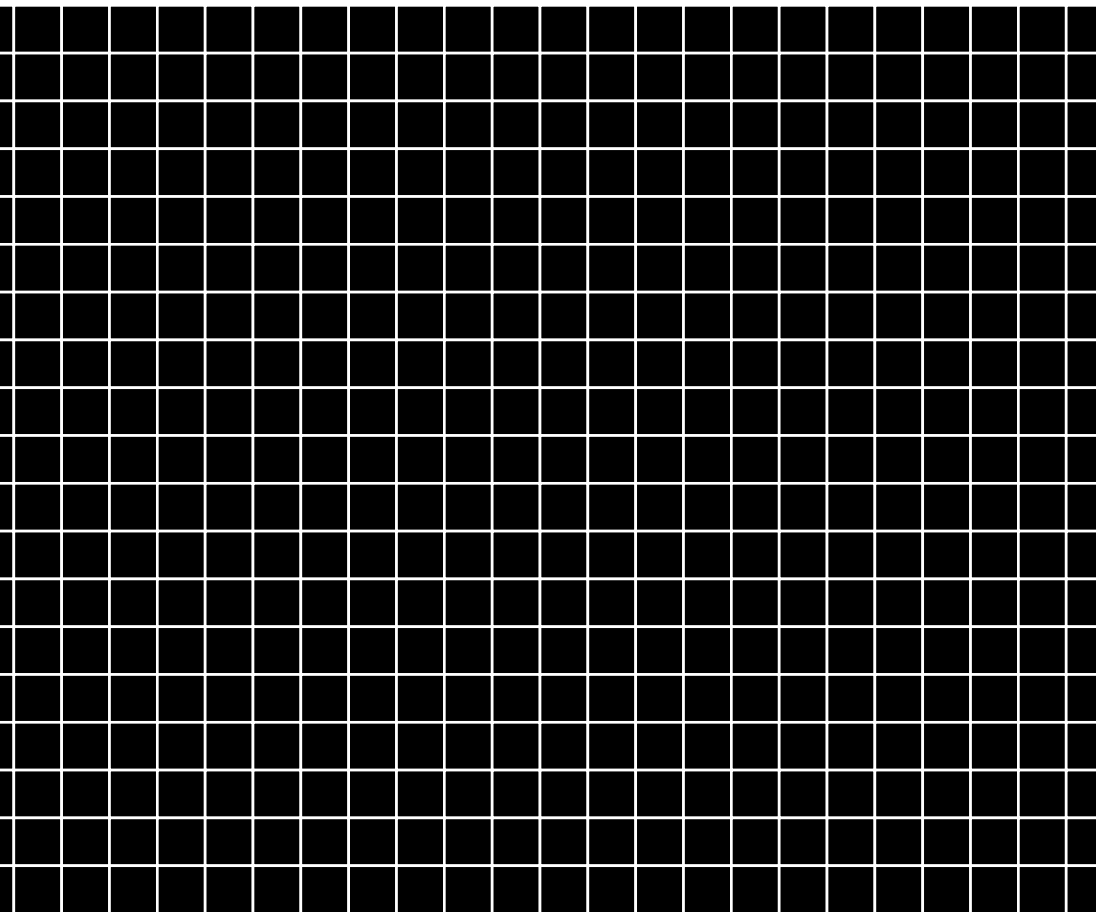

31Z07610
00X31-Z07-6100

EM4

AH
Hi

英

Y

HC

10000.2006.12
Printed in Japan