

Air X

OWNER'S MANUAL

Installation • Operation • Maintenance



Primus Wind Power

938 Quail Street

Lakewood, CO 80215

303-242-5820

MADE IN THE **USA** All Rights Reserved



FOR **MARINE** USE



FOR **LAND** USE

Primus Wind Power, Inc.

Congratulations on your purchase and welcome to our family!

Dear AIR Owner,

Thank you for your purchase of an AIR wind turbine. You have purchased the most advanced battery charging wind turbine in the world! We believe you will find it easy to install your AIR and are confident you will experience years of dependable service from it.

Before going any further, please complete and return the Warranty Registration Card or register on-line at www.primuswindpower.com/warranty. The five-year warranty is effective only after the product has been registered. Note - Primus Wind Power does not sell or distribute your personal information to any third party. We understand and respect your privacy.

If you have any questions or comments, we would like to hear from you. Please call during working hours (Monday-Friday – 8:00am to 5:00pm Mountain Standard Time). Our number is (303)-242-5820. You can also email our Customer Service Department at customer.service@primuswindpower.com.

Again, welcome to our family and thank you for investing in the future of wind energy with a Primus Wind Power AIR turbine.

Sincerely,

Primus Wind Power, Inc.



Enter the serial and model numbers below

Serial Number _____

Model Number _____

The CE marking is a mandatory compliance requirement in EMEA and the UK and although it is self-certified, testing and evidence to support that testing is preferred from an independent test house. All Primus Wind Power turbines are third party tested and fulfil all the relevant provisions of the following Directives:

Machinery Directive 2006/42/EC, Low Voltage Directive 2004/95/EC, Electromagnetic Compatibility Directive 2004/108/EC. The report and the declaration of conformity are available for inspection on request.

The serial number stated on the inside front cover of this owner’s manual refers to a specific Primus Wind Power product. This product is considered compliant to CE.

One - Important Safety Instructions

READ THESE INSTRUCTIONS IN THEIR ENTIRETY BEFORE ASSEMBLING, INSTALLING OR OPERATING YOUR AIR X

- 1) SAVE THESE INSTRUCTIONS. This manual contains important instructions that must be followed during assembly, installation and maintenance.
- 2) Read, understand and respect all warnings.
- 3) Do not install Air X on a windy day.
- 4) If unusual sound or operation is experienced, turn off the machine and perform an inspection. Review this manual to verify that proper assembly and installation procedures have been followed. Contact Primus Wind Power for further assistance.
- 5) During assembly and installation properly torque all fasteners.
- 6) Use only proper grounding techniques as established by the NEC.
- 7) Properly complete and return the Warranty Registration Card.
- 8) Air X must be installed in accordance with this manual and local and national building codes. Failure to comply with this manual and local codes may affect and possibly void your warranty.
- 9) Rotating blades are a serious mechanical hazard. Install Air X so no one can come into contact with blades.
- 10) Observe wire size and fuse recommendations listed in the Wiring Section of this manual.

In this manual you will see the following icons:



IMPORTANT: Indicates instruction or advice that is critical for correct assembly or operation. Damage to equipment may result if not heeded.



TIP: Indicates instruction or advice that may simplify or ease task or operation.



WARNING: Indicates risk of severe injury or death or possible severe damage to equipment - proceed with caution and follow instructions.



LAND USE: Specific to Land Use.



MARINE USE: Specific to Marine Use.

Contents

1) IMPORTANT SAFETY INSTRUCTIONS _____	4	7) AIR BREEZE OPERATION _____	23-25
WARRANTY _____	6	7-1 Operational Summary _____	23
TECHNICAL SPECIFICATIONS _____	7	7-2 Operating Modes _____	23
2) TURBINE ASSEMBLY _____	8	7-3 Voltage Regulation _____	24
3) SITING _____	9	7-3-1 Adjusting Regulation Voltage _____	24
4) TOWERS _____	10-13	7-3-2 Using an Alternate Charge Controller _____	24-25
4-1 Tower Options _____	10	8) MAINTENANCE _____	25
4-1-1 27 ft (8.3 m) Tower Kit _____	11	9) TROUBLE SHOOTING _____	26
4-1-2 29 ft (8.8 m) Tower Kit _____	11	10) EXPLODED VIEWS & PARTS LIST _____	27-28
4-1-3 45 ft (13.7 m) Tower Kit _____	12		
4-1-4 Marine Tower Kit _____	12		
5) WIRING OPTIONS _____	13-20		
5-1 Hybrid System Wiring _____	15		
5-2 Multiple Air X Wiring _____	16		
5-3 Wire Size _____	17-18		
5-4 Stop Switch _____	18		
5-5 Fuses, Circuit Breakers, Ammeter _____	19		
5-6 Batteries _____	19		
5-7 Turbine Grounding _____	19-20		
5-8 Tower Grounding _____	20		
5-8-1 Electrodes Driven in Soil _____	20		
6) INSTALLATION _____	21		
6-1 Wire Connections _____	21		
6-2 Mounting on Tower _____	22		
6-3 Final Connections _____	22		

AIR Wind Turbine Limited Warranty

What is Covered

Primus Wind Power, Inc. ("Primus Wind Power") warrants the AIR Wind Turbine against defects in factory-supplied materials and/or factory workmanship under normal authorized use consistent with the Wind Turbine's Owner's Manual, except for the limitations set forth in this Limited Warranty. Installation of AIR Breeze Wind Turbine constitutes acceptance of the terms and conditions of this Warranty.

How Long Coverage Lasts

This Limited Warranty begins on the following dates, whichever occurs first: (i) date of installation of the Wind Turbine, or (ii) ninety (90) days after the date the original end-user purchaser ("Customer") purchased the Wind Turbine. The customer is encouraged to return the warranty registration document included with this Limited Warranty within sixty (60) days of the start of the Warranty Period. While submission of the warranty registration document does not reduce your eligibility to receive warranty service, you will be requested to provide proof of ownership satisfactory to Primus Wind Power prior to receiving warranty services. You may also visit www.primuswindpower.com/warranty to register your wind turbine online.

Limited Warranty will be provided for up to Five Years from whichever occurs first: (i) date of installation of the Wind Turbine, or (ii) ninety (90) days after the date the Customer purchased the Wind Turbine, or (iii) up to one year after the product is no longer manufactured. This Limited Warranty applies to the wind turbine only provided the owner follows the maintenance procedures outlined in the owner's manual. Should the product prove to be irreparable, Primus Wind Power reserves the right to substitute an equivalent product if available. This Limited Warranty extends to the original Customer and may not be transferred if the wind turbine is sold.

How to Register a Claim Against Warranty

If a defect arises with regard to any Wind Turbine part and a valid claim is received within the Warranty Period, Customer's sole and exclusive remedy and the entire liability of Primus Wind Power, its dealers, suppliers and affiliates under this Limited Warranty is, at Primus Wind Power's sole option, either (i) to repair free of charge the defective part, or (ii) exchange free of charge the defective part with a new or remanufactured part or wind turbine that is new or equivalent to new in performance and reliability and is at least functionally equivalent to the original wind turbine part. Repaired or exchanged wind turbine parts will be warranted for the remainder of the Warranty Period.

If you experience any problem with your AIR Wind Turbine, please contact an authorized service dealer or Primus Wind Power directly. Retain all information and documents until the problem is resolved. Your authorized service dealer can provide you with a solution and start the claims process. For best possible service, we strongly recommend registration of your product with the warranty registration materials provided with your AIR Breeze Wind Turbine. You **MUST** demonstrate ownership with a copy of the original receipt indicating that you are the primary owner of the wind turbine.

To find a Primus Wind Power authorized service dealer near you or to report your claim to technical support, call Primus Wind Power at (303) 242-5820 Monday-Friday 8:00AM – 5:00 PM Mountain standard time.

Warranty claims notification must include a description of the defect, the serial number of the Wind Turbine at issue, and the original purchase date in addition to the name, address, and telephone number of the party requesting warranty service under this Limited Warranty. After Primus Wind Power is notified, Primus Wind Power representatives will make all reasonable efforts via phone and email to ascertain the nature of the problem to determine whether any part is defective for purposes of coverage under this Limited Warranty. Other than normal communication carrier charges, there is no charge for such diagnosis. Any repair or replacement will be provided only after Primus Wind Power's diagnosis and its agreement to the defective condition. Certain diagnostic checks may be required to be performed by the end-user or designee at Primus Wind Power representatives' request. All claims for defect shall be deemed waived unless made in writing and delivered to your Wind Turbine dealer during the Warranty Period and not later than thirty (30) days after discovery of the defect. If Primus Wind Power representatives determine that the Wind Turbine requires service and that Customer's service request constitutes a valid claim under this Warranty, Primus Wind Power will provide warranty service, at Primus Wind Power's sole option, either (i) through an authorized dealer, with service to be performed at the servicer's location; (ii) by sending replacement Wind Turbine or parts to the Customer or (iii) by providing the Customer with a Return Merchandise Authorization ("RMA") number to authorize the Customer to ship the defective Wind Turbine or Wind Turbine parts to Primus Wind Power for service. Any Wind Turbine part(s) requiring warranty repair shall be transported at the expense and risk of the party requiring warranty service, including but not limited to proper packaging of the part(s). Primus Wind Power will return to sender any Wind Turbine and/or part(s) that do not have a valid RMA number. Primus Wind Power will use all reasonable efforts to repair/replace the defective Wind Turbine and/or part(s). Repaired or replaced wind turbines and replacement parts will be delivered to the Customer at Primus Wind Power's expense. If a warranty claim is invalid for any reason, Customer may be charged at Primus Wind Power's and/or the authorized service dealer's then current rate for repair services performed. In such event, the Customer will be informed of the repair charges for prior approval, and, upon approval, will be charged for the approved repairs and return freight. If the Customer refuses to approve repair charges, return freight charges may apply. When a Wind Turbine part is replaced for a new or remanufactured part, such new or remanufactured part becomes Customer's property and the replaced part becomes Primus Wind Power's property. Customer property remaining at Primus Wind Power's repair facilities for more than ninety (90) days without required Customer approval of return freight charges, becomes the property of Primus Wind Power.

(continued)

AIR Wind Turbine Limited Warranty (continued)

Exclusions and Limitations

Primus Wind Power does not warrant that the operation of the Wind Turbine will be uninterrupted, nor does this Limited Warranty guarantee specific performance or energy production under any conditions.

This Limited Warranty does not apply to claims arising from installation of your AIR Breeze Wind Turbine at improper or deficient site locations as described in the Wind Turbine's Owner's Manual. This Limited Warranty does not cover any part that was not manufactured by Primus Wind Power, nor does it cover the costs of any repairs or adjustments to your Wind Turbine that might be needed because of the use of non-Primus Wind Power parts, components, equipment, or materials. This Limited Warranty does not apply to: (i) consumable parts; (ii) cosmetic damage, including scratches or dents unless such damage compromises the product's function; (iii) damage caused by overload, surges, use with any unsuitable power source, voltage irregularities or utility system failures that enter the Wind Turbine through the output side; (iv) damage caused by acts of God (including flood, fire, earthquake, lightning, hail damage, flying debris, wind speeds in excess of 120 mph, tornadoes, hurricanes or other cyclonic windstorms), misuse, negligence, accident, abuse, or vandalism; (v) damage due to a failure to service and maintain, and/or operate the Wind Turbine in accordance with its Owner's Manual or provided instructions; (vi) a Wind Turbine or any of its parts that has been modified to alter functionality or capability without the written permission of Primus Wind Power; (vii) any Wind Turbine part whose serial number has been removed or defaced; (viii) damage or loss to any items or products not manufactured by Primus Wind Power that are connected to, powered by, or otherwise attached to, the Wind Turbine; (ix) any expenses incurred from travel to and from the repair location, troubleshooting, diagnostic and repair services, equipment expenses, or; (x) damage due to improper installation of the Wind Turbine that is not in accordance to the owner's manual or, (xi) use of the wind turbine in wind regimes with an annual average of 18 mph (8 m/s) or greater.

Disclaimer of Warranty

This Limited Warranty gives you specific legal rights, and you may also have other rights which vary from state to state. TO THE EXTENT PERMITTED BY LAW, THIS EXPRESS LIMITED WARRANTY AND THE REMEDIES SET FORTH ABOVE ARE EXCLUSIVE AND IN LIEU OF ALL OTHER WARRANTIES, REMEDIES AND CONDITIONS, WHETHER ORAL, WRITTEN, STATUTORY, EXPRESS OR IMPLIED. AS PERMITTED BY APPLICABLE LAW, Primus Wind Power DISCLAIMS ANY AND ALL STATUTORY OR IMPLIED WARRANTIES, INCLUDING, WITHOUT LIMITATION, THE IMPLIED WARRANTIES OF FITNESS FOR A PARTICULAR PURPOSE, MERCHANTABILITY, NON-INFRINGEMENT AND WARRANTIES AGAINST HIDDEN OR LATENT DEFECTS. IF Primus Wind Power CANNOT LAWFULLY DISCLAIM STATUTORY OR IMPLIED WARRANTIES THEN, TO THE EXTENT PERMITTED BY LAW, ALL SUCH WARRANTIES SHALL BE LIMITED IN DURATION TO THE DURATION OF THIS EXPRESS LIMITED WARRANTY. Primus Wind Power does not grant

to any person or entity (including its field representatives, dealers or distributors) the authority to create for it any obligation or liability in connection with your Wind Turbine.

Limitation of Liability

EXCEPT AS PROVIDED IN THIS EXPRESS LIMITED WARRANTY AND TO THE MAXIMUM EXTENT PERMITTED BY LAW, UNDER NO CIRCUMSTANCES WILL Primus Wind Power, OR ITS AFFILIATES, SUPPLIERS, DEALERS, DIRECTORS, OFFICERS, EMPLOYEES, OR AGENTS (THE "RELEASED PARTIES") BE LIABLE OR RESPONSIBLE FOR, EVEN IF SUCH RELEASED PARTY HAS BEEN ADVISED OF THE POSSIBILITY OF SUCH DAMAGE, ANY DIRECT, SPECIAL, INCIDENTAL OR CONSEQUENTIAL DAMAGES RESULTING FROM ANY BREACH OF WARRANTY OR CONDITION, OR UNDER ANY OTHER LEGAL THEORY OR FORM OF ACTION (WHETHER IN CONTRACT, TORT (INCLUDING NEGLIGENCE), STRICT LIABILITY OR OTHERWISE), INCLUDING, BUT NOT LIMITED TO, ANY LOSS OF USE, INTERRUPTION OF OR LOSS OF BUSINESS, LOSS OF ACTUAL OR ANTICIPATED PROFITS (INCLUDING LOSS OF PROFITS ON CONTRACTS), LOSS OF REVENUE, LOSS OF THE USE OF MONEY, LOSS OF ANTICIPATED SAVINGS, LOSS OF OPPORTUNITY, LOSS OF GOODWILL, LOSS OF REPUTATION, LOSS OF, DAMAGE TO OR CORRUPTION OF DATA, OR ANY INDIRECT OR CONSEQUENTIAL DAMAGES HOWEVER CAUSED, INCLUDING THE REPLACEMENT OF EQUIPMENT AND PROPERTY, BODILY INJURY OR DEATH. (Note: some states do not allow the exclusion or limitation of incidental or consequential damages, so these limitations may not apply to you.) The total cumulative liability to Customer, from all causes of action and all theories of liability, will be limited to and will not exceed the purchase price of the Wind Turbine paid by Customer.

Product Changes

Primus Wind Power reserves the right to make changes, improvements or additions to its products in the future without incurring obligations to make such changes, improvements, or additions to its products previously manufactured. Occasionally, a product change, improvement or addition will be made that either prevents future failure of a product or part or eliminates a safety hazard. Primus Wind Power will then issue a field change order to correct this problem. Installation of the mandatory field change order must be done within thirty (30) days of field change order issuance or this Limited Warranty will be void should failure occur as a result of not installing said parts. Primus Wind Power reserves the right to change the terms of this Limited Warranty in the future without incurring any obligations to make the changed terms applicable to products previously manufactured.

(continued)

AIR Wind Turbine Limited Warranty (continued)

Additional Terms that Govern this Limited Warranty

Each of us (i) agrees that all actions and proceedings relating directly or indirectly to this Limited Warranty shall be litigated in state or federal courts located in Jefferson County, Colorado; (ii) consents to the jurisdiction and venue of any such court and consents to service of process in any such action or proceeding by personal delivery or any other method permitted by law; and (iii) waives any and all rights either of us may have to object to the jurisdiction of any such court, or to transfer or change the venue of any such action or proceeding. WE FURTHER EACH WAIVE THE RIGHT TO TRIAL BY JURY IN ANY ACTION OR PROCEEDING BASED UPON, ARISING OUT OF, OR IN ANY WAY RELATING TO, THESE TERMS AND CONDITIONS. We further agree that this Limited Warranty may not be extended, altered or waived except in writing signed by an authorized officer of Primus Wind Power. ANY ACTION FOR BREACH HEREUNDER MUST BE COMMENCED WITHIN ONE YEAR AFTER THE CAUSE OF ACTION HAS ACCRUED. Primus Wind Power shall be entitled to recover legal fees, costs and expenses in defending and enforcing this Limited Warranty against Customer and others. This Limited Warranty shall be construed and enforced in accordance with the laws of the State of Colorado without regard to conflicts of laws.

Air X Technical Specifications

Model	Air X
Weight	13 lb / 6 kg
Rotor Diameter	46 in / 1.17 m
Start Up Wind Speed	8 mph / 3.6 m/s
Kilowatt Hours/month	38 kWh/month @ 12 mph / 5.4 m/s avg. wind speed
Maximum Wind Speed	110 mph
Rated Power	400 watts @ 28 mph / 12.5 m/s wind speed
Certifications:	CE

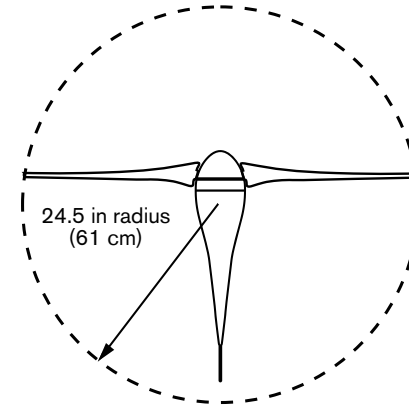

Voltage Regulation Set Point (factory setting)

12 Volt Systems	14.1 Volts
24 Volt Systems	28.2 Volts
48 Volt Systems	56.4 Volts

Regulator Adjustment Range

12 Volt Systems	13.6 to 17.0 Volts (approximately)
24 Volt Systems	27.2 to 34.0 Volts (approximately)
48 Volt Systems	54.4 to 68.0 Volts (approximately)

Recommended Fuse Size

12 Volt Systems	40 amp (slow blow)
24 Volt Systems	20 amp (slow blow)
48 Volt Systems	10 amp (slow blow)

Tower Loads

Shaft Thrust* 52 lb @ 100 mph wind speed (230 N @ 45 m/s)

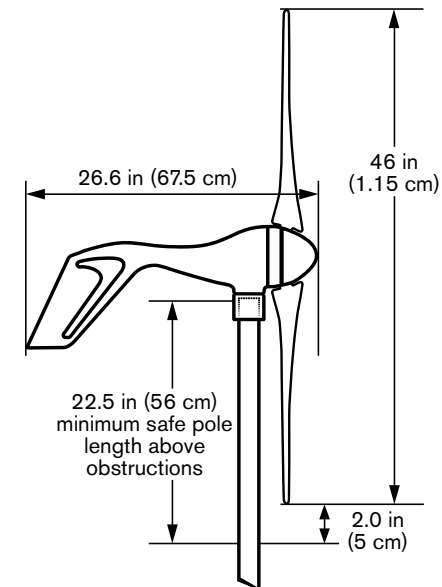

*Value does not include safety factor. Primus Wind Power recommends safety factor of 1.5.

Two - Air X Turbine Assembly

Your Air X is delivered partially assembled. Assembly requires mounting the blades on the blade hub, securing the hub to the turbine body and installing the nosecone on the blade hub. The necessary hex key (Allen) wrenches are furnished with Air X.

Torque Specifications:

Blade to hub bolts, 1/4-20 x 1.25 inch, Socket Head Bolt, 7.0 lb-ft (9.4 N·m)

Hub to rotor nut, 5/8 -18 inch, Jam nut, 50 lb-ft (68 N·m)

Yaw Clamp Bolts, M5 x 35 mm, Socket Head Bolt, 4.0 lb-ft (5.4 N·m)

Start the assembly by examining how the blades mount to the hub, refer to **Fig 1**. Using the Tef-Gel supplied with the Air X, apply a coat of Tef-Gel to the blade root and hub. The use of Tef-Gel is recommended for all installations but is mandatory in marine environments.

The goal is to provide a coating of Tef-Gel between the blade root and blade hub so that the blade material does not directly contact the aluminum hub. This is particularly important for marine installations since the blades and hub may severely deteriorate in high moisture (particularly marine) environments.

IMPORTANT: Tef-Gel is a corrosion inhibitor and is especially important in marine applications.

After coating the hub and blades with Tef-Gel place a nylock nut (Item 4) in the detent on the back of the blade hub while positioning a blade on the hub. Pass a bolt through the blade and screw it into the nylock nut – do not fully tighten the bolt yet. Install the second bolt and nylock nut and lightly torque both bolts to temporarily hold the blade in place. Install the remaining two blades following the same procedure. Measure tip to tip distance between the three blades and align as needed to measure as equal a distance apart as possible. Torque all blade bolts to 7 ft-lbs. (9.4 Nm).

If Air X is to be installed on a “tilt-up” tower, mount the blade/hub assembly to the turbine now. Start the 5/8-18 hub nut on shaft threads and

“spin” the hub completely onto the turbine alternator shaft. Fully tighten the hub to 50 ft-lbs (68 Nm) by inserting a 5/16 inch hex key wrench in the turbine alternator shaft and turning the shaft while turning the blades. **Caution** - blades are sharp!



WARNING: Don't attempt to mount the turbine while blades are spinning.

If Air X is to be installed after the tower is erected, it will be safer and easier to first install the turbine body on the tower and then install the hub/blade assembly. This will avoid attempting to mount the turbine while the blades are spinning – a dangerous condition.

Snap the nosecone into position over the outside edges of the blade hub. Make sure all three edges of the nosecone snap over the edge of the blade hub. After installation tug on the nosecone to make sure it is securely attached.

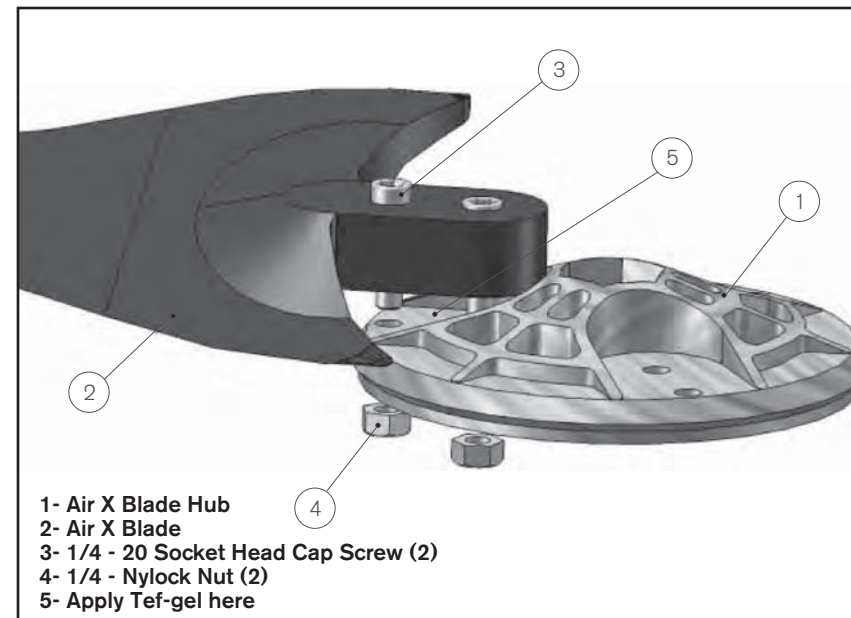

Fig. 1 Air X Blade Attachment Detail.

Three - Air X Siting

Small changes in wind speed can have a dramatic effect on power production. The siting of your wind turbine should be carefully considered. Each installation is different and is often a compromise among tower height, distance from the battery bank, local zoning requirements and obstacles such as buildings and trees.

In general the higher the tower, the greater the wind speed and ultimately power production. However, towers are expensive and can easily exceed the cost of the turbine.

The minimum recommended tower height is 25 ft (7.6 m) on open ground or 30 ft (9 m) above obstacles within a 300 ft. (91.4 m) radius from the tower base. **(Fig. 2)** Try to locate the wind turbine in the “cleanest” turbulent free air as possible. Turbulence will reduce the efficiency of the wind turbine and may accelerate wear on rotating components.

Safety must be the primary concern when selecting the mounting location. Install Air X so there is no possibility of accidental contact with rotating blades even if it requires installing the wind turbine in a less than ideal location. Safety has precedence over efficiency.



WARNING: Install Air X so there is no possibility of accidental contact with rotating blades even if it requires installing the wind turbine in a less than ideal location.

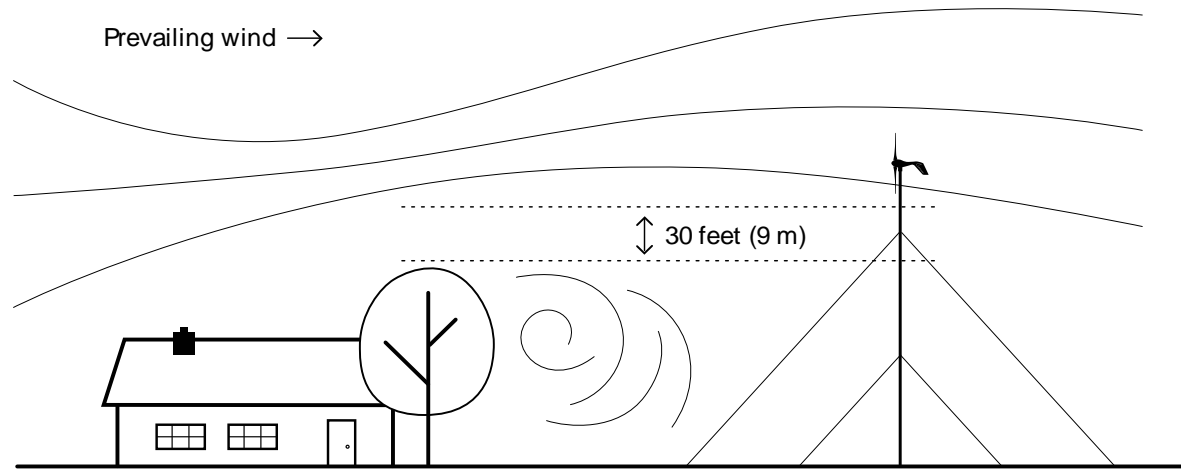

Fig. 2 Optimal Air X location.

Four - Air X Towers

The Air X is designed to mount on tubing or pipe with a nominal 1.875 – 1.900 inch outside diameter. This dimension enables constructing a tower from a range of readily available materials including 1 1/2 inch Schedule 40 steel pipe and 2 inch SS-20 galvanized fence tubing (0.090 inch wall thickness). Under no circumstances should plastic pipe be used to construct a tower.



WARNING: Plastic pipe should NEVER be used to construct a tower.



IMPORTANT: User manuals for towers and tower kits are available online at www.primuswindpower.com. Primus Wind Power recommends reviewing them to make an appropriate tower selection for your Air X.

4-1 Tower Options

Primus Wind Power offers a number of tower choices for Air X. The following section provides a summary of the available towers. User manuals for the towers and tower kits are available online and you are encouraged to review them in order to make the most informed tower selection. See **Fig. 3**.

Fig. 3. Tower Options

27 ft (8.3 m) Tower

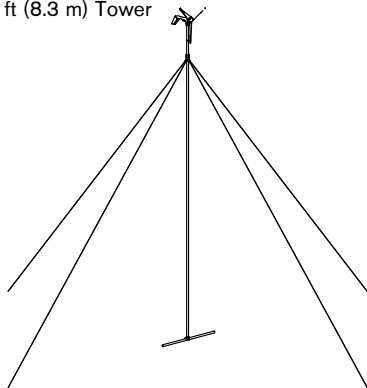

29 ft (8.8 m) Tower

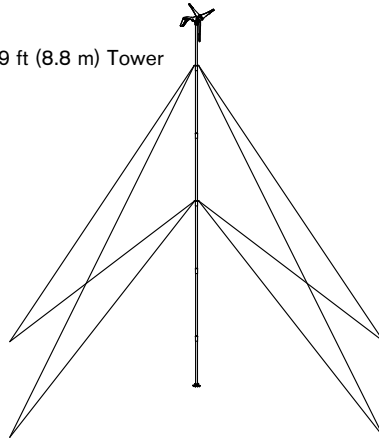

45 ft (13.7 m) Tower

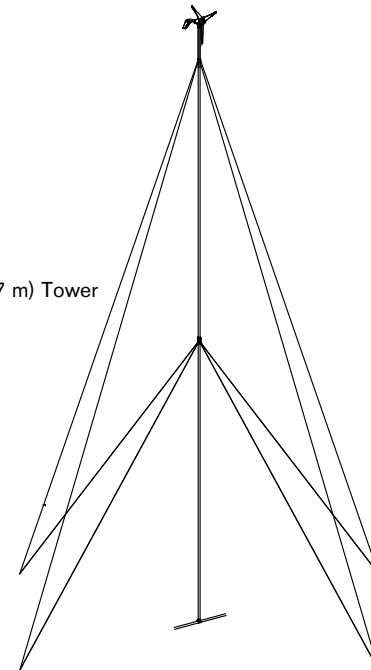

4-1-1 27 ft (8.3 m) Tower Kit

The 27 ft (8.3 m) Tower Kit includes a tower clamp/guy wire assembly and all necessary hardware and fasteners to erect a 27 ft tilt-up tower using Schedule 40 steel pipe or tubing with an outside diameter of 1.875 inch. See **Fig. 4**.

Note: Anchors, pipe or tubing and electrical wire are not furnished with the kit, so you have the flexibility to use the most appropriate components for the installation.

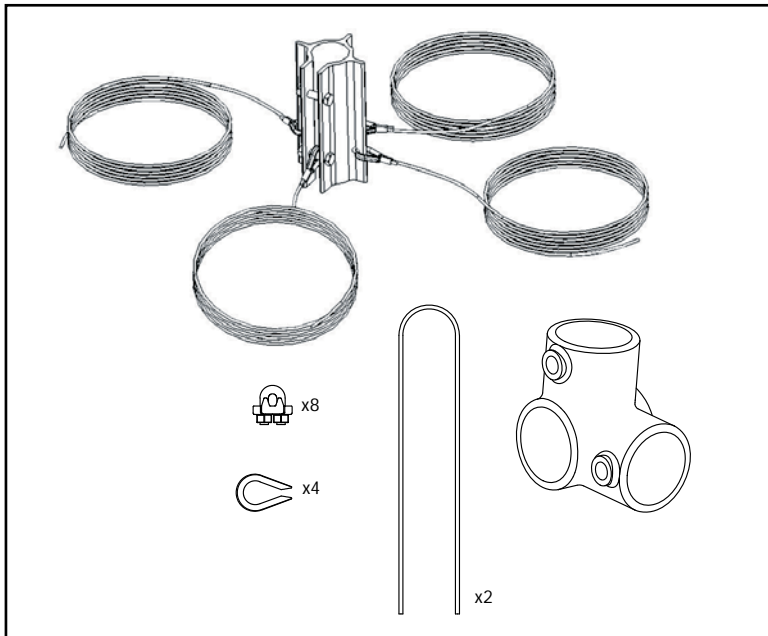

Fig. 4. 27 ft (8.3 m) Tower Kit

4-1-2 29 ft (8.8 m) EZ – Tower

The 29 ft (8.8 m) EZ Tower is a complete kit that includes all materials required to assemble a 29 ft guy wire tilt-up tower. Anchors, guy wire assemblies, galvanized steel tubing and all fasteners are included with the kit. See **Fig. 5**.

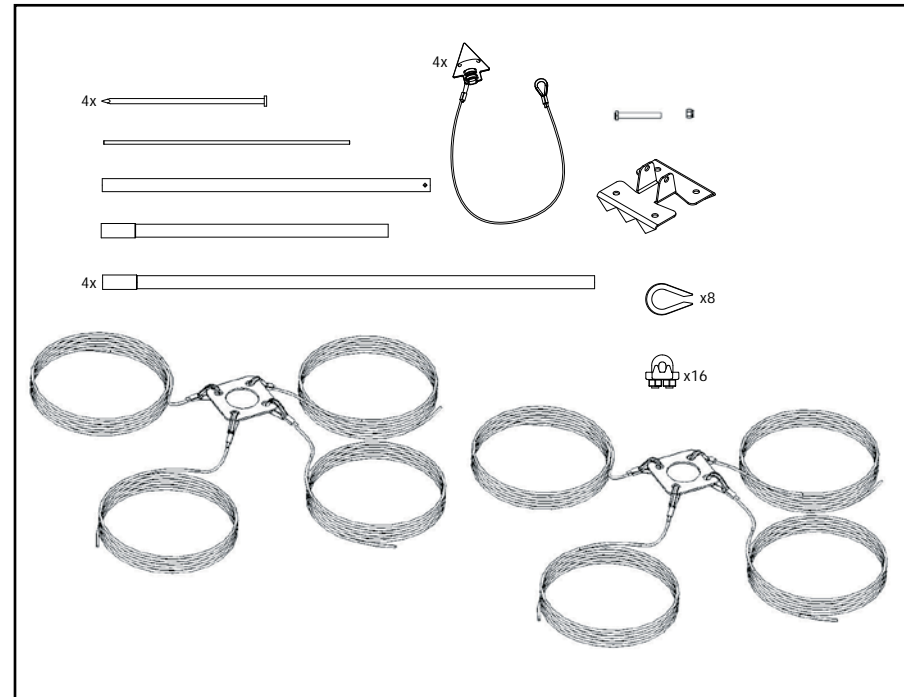

Fig. 5. 29 ft (8.8 m) Tower Kit

Five - Air X Wiring Options

The recommended way to connect the turbine to your battery bank is to wire the turbine directly to its own set of battery posts. This will allow the turbine to operate independently. The Air X's internal regulator will monitor the battery and maintain the charge as necessary.

Figs. 9 and 10 represent typical single turbine installations. **Fig. 10** includes an up-tower junction box for National Electric Code compliance. Contact Primus Wind Power for more information about this configuration.

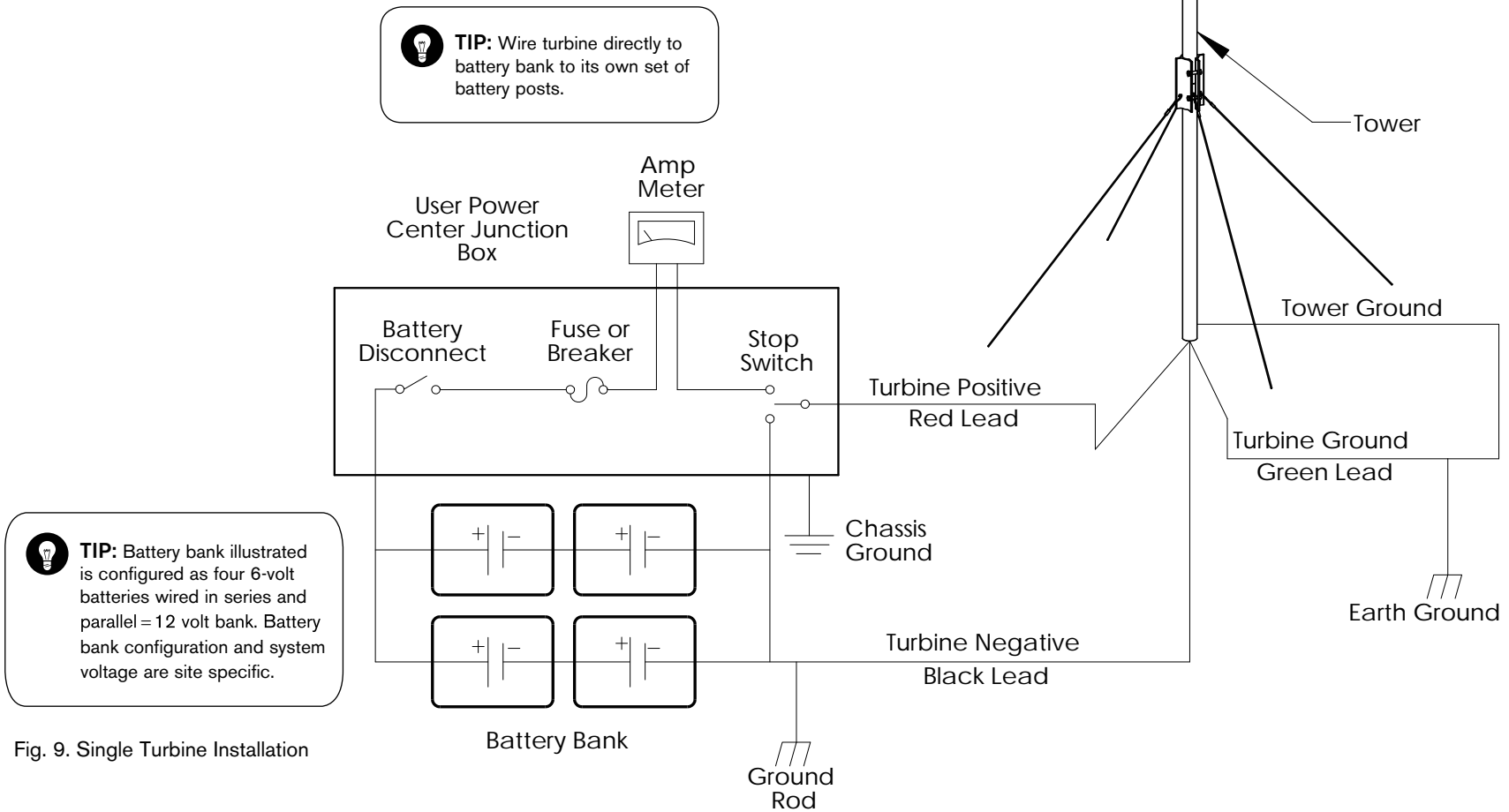

Fig. 9. Single Turbine Installation

Fig. 10 represents a system with an Up Tower Junction Box. The junction box may be installed close to the top of the tower to ease installing a Lightning Arrestor. Typically installing the box will require drilling holes in the tower to install the box – be careful not to compromise the tower strength.

TIP: Battery bank illustrated is configured as four 6-volt batteries wired in series and parallel = 12 volt bank. Battery bank configuration and system voltage are site specific.

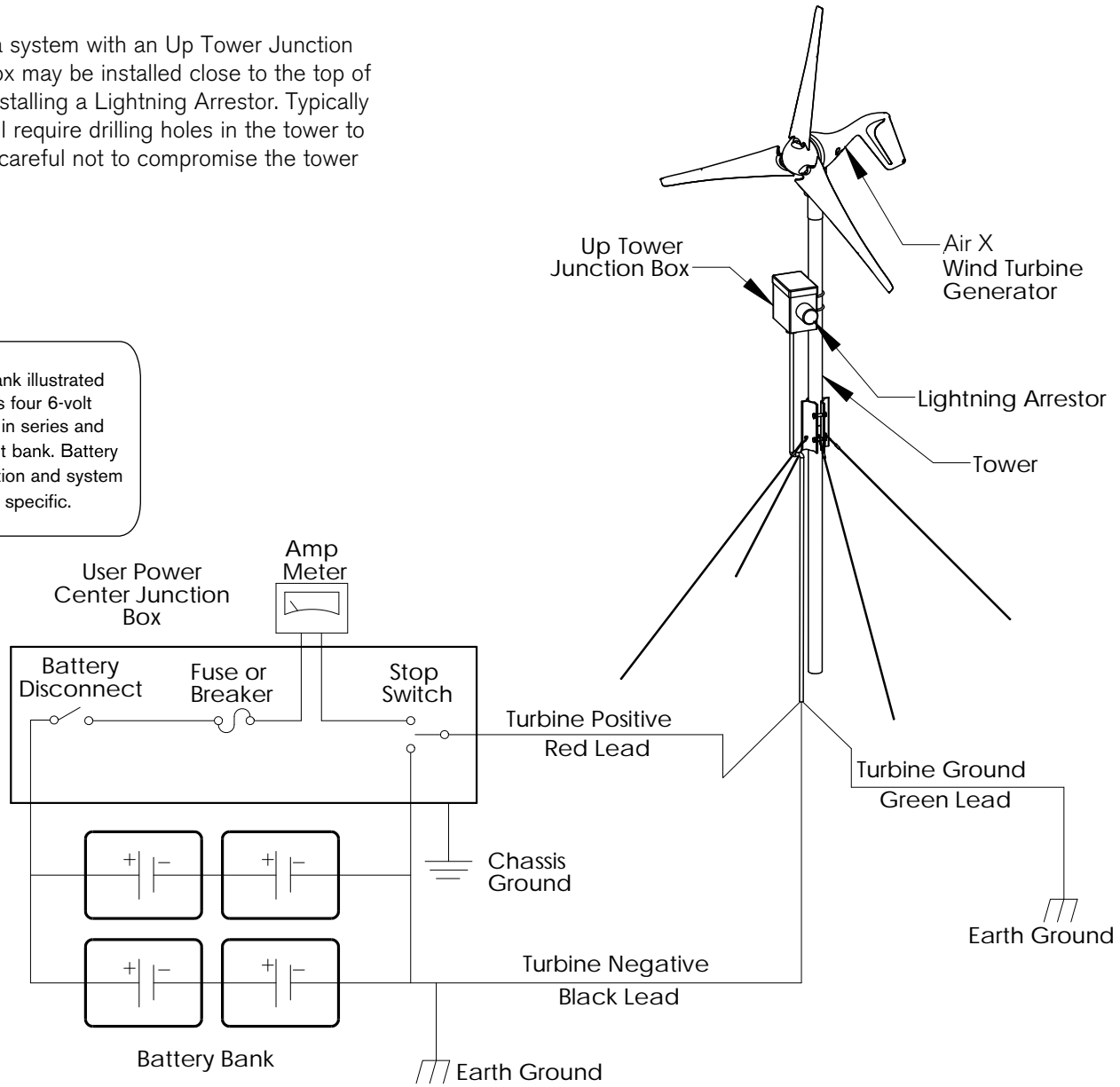

Fig. 10. Single Turbine Installation with Up-Tower Junction Box

5-1 Hybrid System Wiring

Fig. 11 represents a typical “hybrid” system with solar panels. Some charging sources (solar panels, fuel-powered generators, additional wind generators, etc.) connected to the same system may cause interference with the Air X internal electronics and result in pre-regulation. The interference will not harm the turbine; it will just cause it to spin slowly as if “braked” or it may stop the turbine. If this occurs, test for possible interference by disconnecting the other charging sources to determine the possible cause. If possible wire the turbine and PV panels to their own set of battery posts.



TIP: In this figure the Air X internal regulator is used. A diversion type external regulator could also have been used.



TIP: Voltage “pre-regulation” may be prevented by increasing the regulation set point. See section 7-3-2.



TIP: Battery bank illustrated is configured as four 6-volt batteries wired in series and parallel = 12 volt bank. Battery bank configuration and system voltage are site specific.

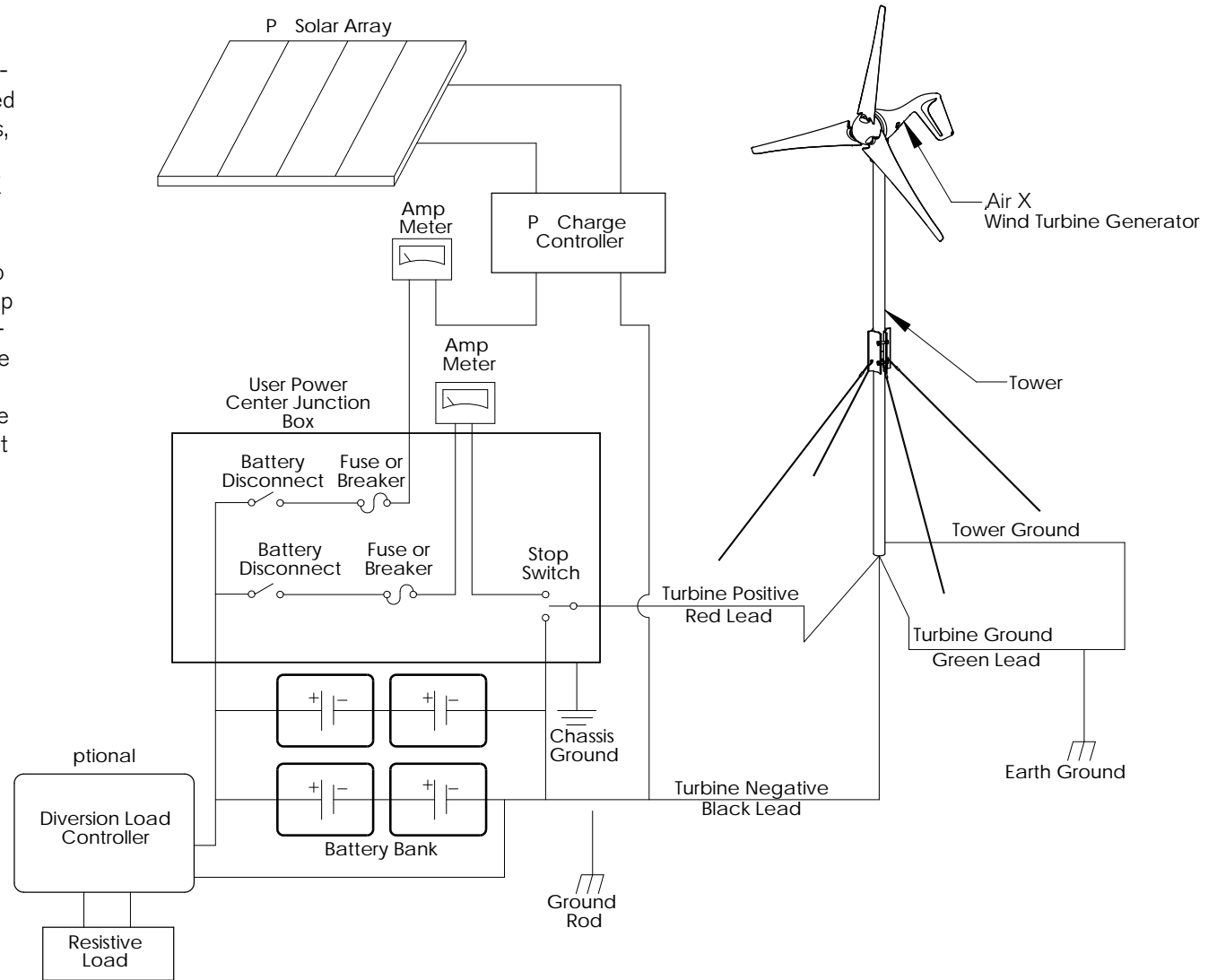

Fig. 11. Hybrid System with Solar Panels

5-2 Multiple Air X Wiring

It is possible to wire multiple Air X turbines together. A typical multi-turbine system is depicted in **Fig. 12**.

There are two methods used to accomplish this task.

Method One:

Each Air X is treated separately. Each turbine will have its own wires, stop switch and fuse and will connect directly to the battery using the internal regulator to control charging.

Method Two:

Wire each turbine to a "bus" and then run one set of wires from the bus to the battery. Each turbine's internal regulator or an external diversion type regulator may be utilized. A "bus" system typically results in reduced wire costs.

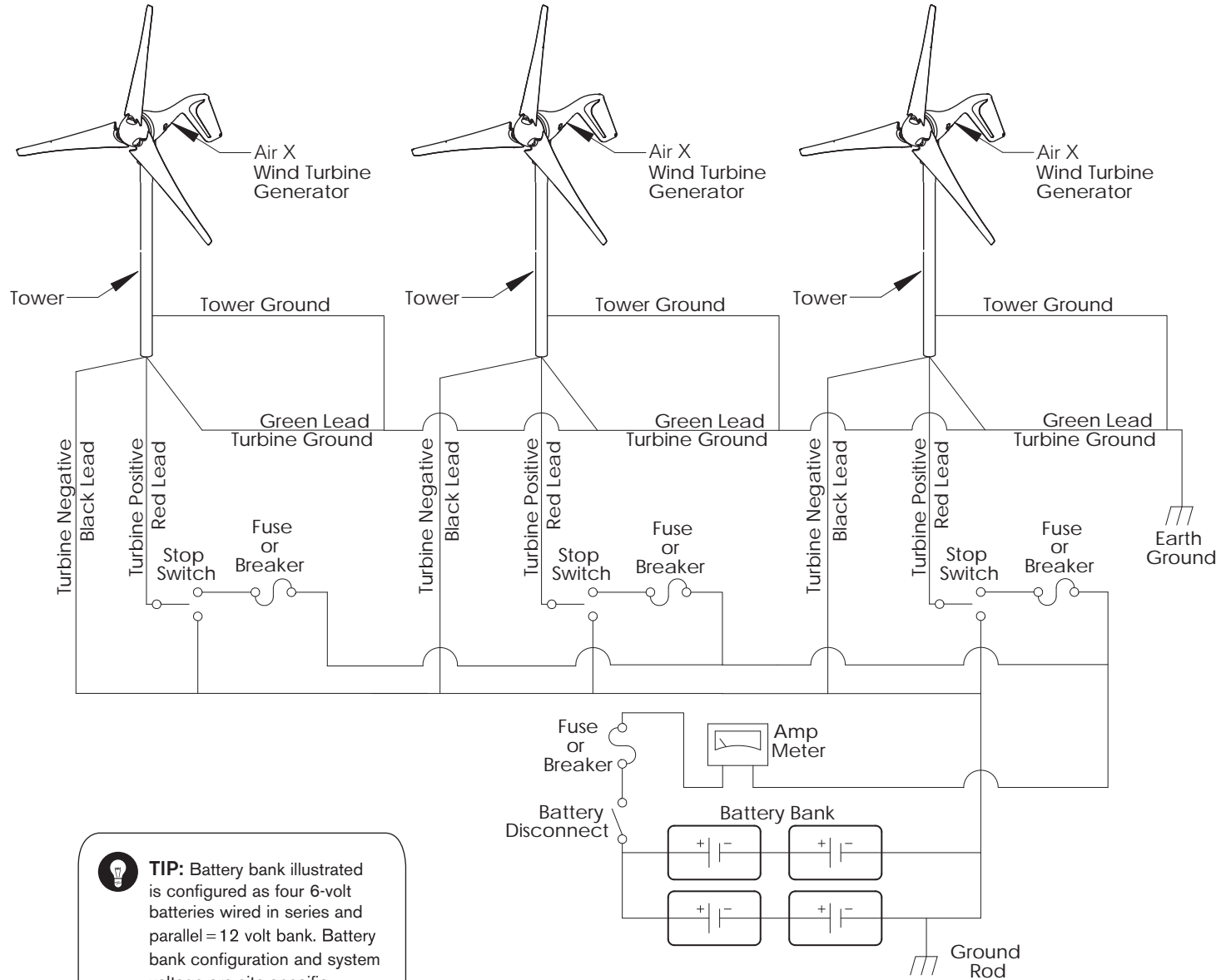

TIP: Battery bank illustrated is configured as four 6-volt batteries wired in series and parallel = 12 volt bank. Battery bank configuration and system voltage are site specific.

Fig. 12. Multiple Air X Wiring

5-3 Wire Size

All electrical systems lose energy due to resistance in conductors.

- Large wires have less resistance but can be considerably more costly.
- Resistance losses will also increase with increasing current, therefore, if yours is a high wind site, it may be worthwhile to go with a larger size wire to take advantage of the greater energy production potential of your site.
- Conversely, in low wind sites it may not be cost effective to increase the wire size since power production will be low.

The following wiring sizes provide maximum annual energy losses of 5% or less for sites with a 12 mph average wind speed (assuming the standard Rayleigh distribution of wind speeds) which is sufficient for most sites.

To determine the size wire, measure the distance from the batteries to your Air X. Be sure to include height of the tower. Refer to the appropriate chart for your system voltage and number of turbines and select the wire size.

We recommend these as the minimum wire sizes; for optimal performance use the largest wires that are practical and affordable. Local, state, and national electrical codes have precedence over these recommendations and must be followed to ensure the safety of your system.

Note: Wiring Resistance and Regulation

Depending on your exact system configuration including other charging sources in your system, wiring resistance may affect the regulation set point of the turbine. Higher wiring resistance (smaller wires) will tend to lower the voltage at which the turbine enters regulation and stops charging. The recommended wiring sizes should provide little effect on the regulation set point, but all installations should be observed over time to ensure that the batteries are charged to the proper voltage.



TIP: Smaller wires will lower the voltage at which the Air X enters regulation and stops charging.

12 Volt Systems, AWG / Metric Wire Size mm²

Number of Turbines:	0-30 ft (0-9 m)	30 ft-60 ft (9-18 m)	60 ft-90 ft (18-27 m)	90 ft-150 ft (27-46 m)	150 ft-190 ft (46-58 m)	190 ft-250 ft (58-76 m)	250 ft-310 ft (76-95 m)	310 ft-390 ft (95-119 m)	390 ft-500 ft (119-152 m)
1	8/10 mm ²	6/16 mm ²	4/25 mm ²	2/35 mm ²	1/50 mm ²	0/50 mm ²	00/70 mm ²	000/90 mm ²	000/90 mm ²
2	6/16 mm ²	4/25 mm ²	1/50 mm ²	00/70 mm ²	000/90 mm ²	0000/120 mm ²	***	***	***
3	4/25 mm ²	2/35 mm ²	0/50 mm ²	000/90 mm ²	0000/120 mm ²	***	***	***	***

*** If your system requires this length of wire, consider using parallel wires.

24 Volt Systems, AWG / Metric Wire Size mm²

Number of Turbines:	0-30 ft (0-9 m)	30 ft-60 ft (9-18 m)	60 ft-90 ft (18-27 m)	90 ft-150 ft (27-46 m)	150 ft-190 ft (46-58 m)	190 ft-250 ft (58-76 m)	250 ft-310 ft (76-95 m)	310 ft-390 ft (95-119 m)	390 ft-500 ft (119-152 m)
1	14/2.5 mm ²	12/4 mm ²	10/6 mm ²	8/10 mm ²	6/16 mm ²	4/90 mm ²	4/90 mm ²	000/90 mm ²	000/90 mm ²
2	12/4 mm ²	8/10 mm ²	6/16 mm ²	4/25 mm ²	4/25 mm ²	2/35 mm ²	2/35 mm ²	1/50 mm ²	0/50 mm ²
3	10/6 mm ²	8/10 mm ²	6/16 mm ²	4/25 mm ²	2/35 mm ²	2/35 mm ²	1/50 mm ²	0/50 mm ²	00/70 mm ²

48 Volt Systems, AWG / Metric Wire Size mm²

Number of Turbines:	0-90 ft (0-27 m)	90 -250 ft (27-76 m)	250 -310 ft (76-95 m)	310 -500 ft (95-152 m)
1	14/2.5 mm ²	12/4 mm ²	10/6 mm ²	8/10 mm ²
2	12/4 mm ²	8/10 mm ²	6/16 mm ²	4/25 mm ²
3	10/6 mm ²	8/10 mm ²	6/16 mm ²	4/25 mm ²

5-4 Stop Switch

Primus Wind Power recommends the use of a stop switch to provide a convenient and safe method for shutting down your Air X. A switch is supplied with each Air X Marine as standard equipment and is available for purchase from Primus Wind Power for the Air X Land.

Install the switch as shown in **Fig. 13**. A “break then make” switch **MUST** be used or severe damage may occur. When wired as shown, Air X will operate normally with the switch in the “up” position and will be “off” in the “down” position. Do not leave switch in “middle” position; this will place Air X in an open circuit condition – see the Operating Modes section of this manual.

The stop switch model offered by Primus Wind Power is sufficient for most systems, but it should not be used in applications where a code compliant switch is necessary.

NOTE: The center post must be positive from the turbine. Outside posts can be swapped as either battery positive or battery/turbine negative.

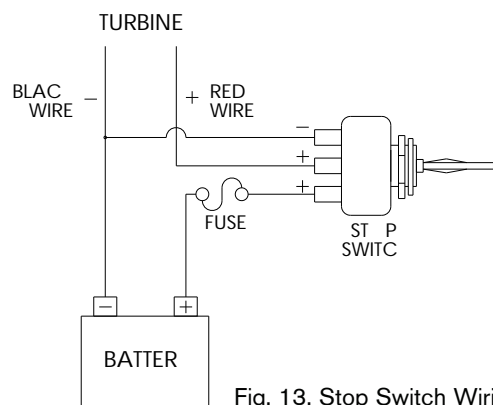

Fig. 13. Stop Switch Wiring



MARINE USE:
A Stop Switch is standard equipment with the Air X Marine.

Stop Switch Assembly

1. Use either the rubber sleeved nut or the knurled nut but do not use both.
2. Drill 12 mm (0.4725 in) hole in panel.
3. The backing jam nut may be adjusted to allow the switch to mount flush with the panel.
4. No larger than 8 gauge wire should be connected directly to switch. Short lengths (a few inches) of 8 gauge wire may be used as a transition to larger gauge wire. Eye connectors are recommended.
5. Wires should be supported. Provide strain relief – the switch terminals are not designed to support lengths of wire.

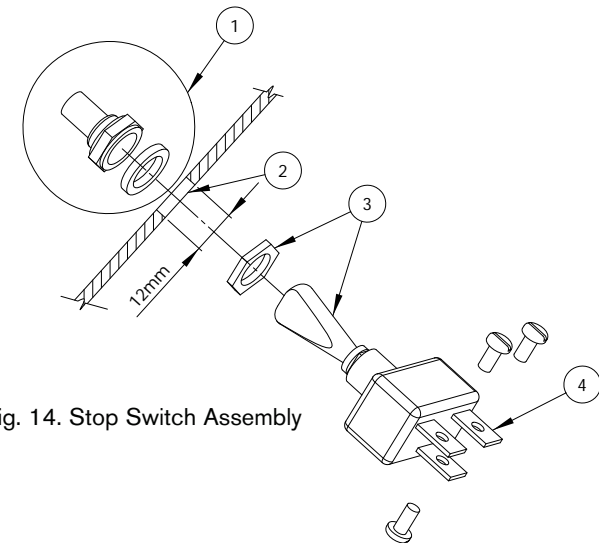

Fig. 14. Stop Switch Assembly

5-5 Fuses, Circuit Breakers and Ammeter

Air X is capable of producing high amperages. As with all electrical installations, you must protect each of your turbines with a fuse or circuit breaker. Wire Air X with an appropriate size “slow-blow” fuse or circuit breaker between it and the batteries. Refer to installation figures at the start of **Section 5**. If a stop switch is used, the fuse or circuit breaker should be placed between the switch and the batteries.

Recommended Sizes for Circuit Breakers or Slow-Blow Fuses

- 12-volt model: 40 amp DC
- 24-volt model: 20 amp DC
- 48-volt model: 10 amp DC

Circuit Breakers are available from Primus Wind Power. Part numbers are listed above.

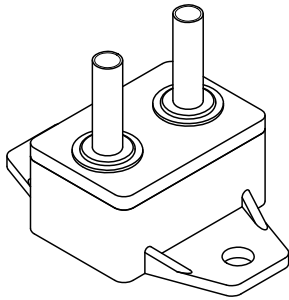

Fig. 15 Circuit Breaker



**Fig. 16 Ammeter
(Amp Meter)**

PN 2-ARAC-102

While not necessary, an ammeter (sometimes called an Amp Meter) is an excellent addition to any system. The Amp Meter allows you to monitor the current output of your turbine. Place it in between your turbine and the battery on the positive lead. It will give you instantaneous readings of output in amps.

! TIP: The Air X emits a small, high-frequency AC ripple, possibly causing compatibility issues with some battery monitoring systems. Use of an AC filtering device is suggested in these circumstances.

5-6 Batteries

There are many battery choices available – flooded lead acid, absorbed glass mat (AGM), gel cell and NiCad. The type of battery utilized will depend largely on the battery bank location and cost. For battery installations where fumes can be safely ventilated and the potential for acid leakage accommodated, the flooded lead acid battery is typically the most economical choice.

Minimum recommended battery bank size:

- 12-volt systems – 400 Amp-hours
- 24-volt systems – 200 Amp-hours
- 48-volt systems – 200 Amp-hours

There are several informative web sites with battery information including:

- www.batterycouncil.org
- www.windsun.com/Batteries/Battery_FAQ.htm



IMPORTANT: Never use “automotive” batteries or any battery other than a “deep-cycle” battery.

5-7 Turbine Grounding

Proper grounding of the Air X provides protection to individuals and equipment by eliminating the possibility of dangerous voltage potentials.

There are two aspects to grounding any electrical system – grounding one of the conductors of the electrical system and grounding all metal structures in the system that may have a voltage potential caused by an electrical failure.

In a typical Air X installation grounding one of the conductors is accomplished by connecting the Air X negative (black) conductor to an “earth” ground close to the battery bank. Installation and connection to grounding rods is described in the following section on Tower Grounding.

Grounding the metal structures in the system – typically this includes the tower and turbine – is accomplished by connecting the structures together using conductors of the same size as the positive and negative conductors and then routing a conductor to an earth ground.

The following section (5-8) describes grounding the tower in detail. To ground the Air X turbine body, connect the Air X ground (green) conductor to the tower ground rod. Alternately the ground (green) conductor may be connected to the negative (black) conductor in which case it will be grounded through the battery bank ground rod. Refer to figures 9 through 12.

Note that all system grounds should be connected using conductors of the same size as the positive and negative wires.

If you choose to not set up an earth ground system (not required for systems under 50 volts), the Air X green and black conductors MUST be connected to each other or severe damage to Air X may result and void your warranty. Grounding is necessary to lessen the potential for EMI interference with electronics.

Primus Wind Power strongly recommends that boat installations be grounded according to American Boat and Yacht Council recommendations. There are special grounding requirements for boats, in particular boats that connect to shore AC power, that MUST be observed or a serious shock hazard may result. Contact the American Boat and Yacht Council.

5-8 Tower Grounding

Every wind turbine and turbine tower should be grounded at the tower base even though the system may be grounded at the battery bank or service panel by means of the yaw ground lead. Grounding the tower at its base may prevent shocks to persons touching the tower due to lightning or electrical faults.

The following sections are provided as a guide to properly grounding the tower and should not be considered completely comprehensive. You are encouraged to reference the National Electrical Code (NEC) and local building and zoning regulations for complete requirements. Relevant sections of the National Electrical Code are referenced.

Tower grounding may be accomplished in several ways; the most common method is a copper clad steel electrode(s) driven into the soil and connected to the tower using a wire conductor.

5-8-1 Electrodes Driven in Soil

Electrodes should be a minimum of 8 ft (2.5 m) in length and free of non-conductive coatings such as paint. Hollow electrodes of pipe or conduit should not be smaller than trade size 3/4 (metric designator 21) and must be galvanized or otherwise protected from corrosion. Solid rod electrodes must be at least 5/8 inch (16 mm) diameter. Stainless steel rods less than 5/8 inch diameter, nonferrous rods or their equivalent less than 1/2 inch diameter shall be "listed" by an organization having jurisdiction in the area. For example: UL in the USA and CSA in Canada.

Electrodes shall be installed such that 8 ft (2.5 m) is in contact with the soil. They should be driven into undisturbed soil within 1 ft of the tower foundation. Electrodes should be driven to a depth of 8 ft (2.5 m) except where rock is encountered; then the electrode may be driven at an angle not to exceed 45 degrees from vertical. Some local authorities permit burial of the electrode in a trench that is a minimum of 30 inch (76 cm) deep.

The upper end of the electrode and its connection to the grounding conductor should be below grade or if above ground, must be protected from damage.

Bonding the grounding conductor to the electrode and to the tower may be accomplished by exothermic weld or by a "listed" mechanical connector. Solder connections are not permitted. Most local authorities require a minimum grounding conductor size of 6 AWG for copper and 4 AWG for aluminum (if aluminum is permitted).

The grounding conductor may be buried directly or contained in conduit; in either case it is important that it have no sharp bends to keep its inductance low.

The accompanying figure (see page 23) depicts a typical tower grounding technique and the following sections of the NEC are listed for reference.

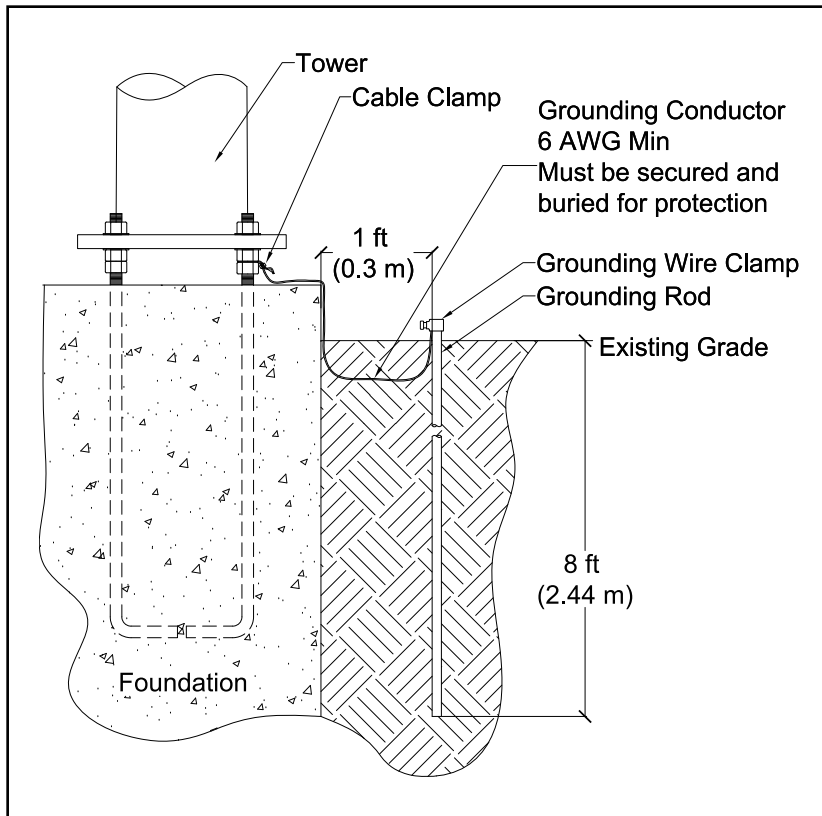

2005 NEC Section

Article 250.52, item 5
 Article 250.53, item A
 Article 250.53, item G
 Article 250.64
 Article 250.66, item A
 Article 270.70

Topic

Tower Grounding
 Tower Grounding
 Grounding Electrode Installation
 Grounding Conductor Routing and Placement
 Grounding Conductor Size
 Bonding of Grounding Conductor

Six - Air X Installation

The following are general guidelines for the installation of Air X. Because each wind turbine installation is unique, specific step-by-step installation instructions cannot be provided. However, before attempting final installation the following basic steps should be completed:

- Completely review Air X Owner's Manual.
- Select tower and site and install tower. **See sections 3.0 and 4.0.**
- Determine wire size. **See Section 5.3.**
- Design system including batteries, switches, circuit breakers – draw wiring diagram.
- Obtain required components.
- Assemble turbine – **See Section 2.0 Turbine Assembly.**

Once these steps are completed, final assembly is fairly simple and consists primarily of making good electrical connections according to the wiring diagram and mounting Air X on the tower.

6-1 Wire Connections to Air X



WARNING: Do not connect wires to batteries until all electrical connections are completed.

Connect wire leads from Air X to wires to be run down the tower using “split bolt” or solder connectors. Follow good practice and use color coded wires – red for battery positive, black for battery negative, and green for earth ground. Wires must be sized based on turbine to battery bank distance. Refer to **Section 5**. Insulate connections with heat shrink tubing or good quality electrical tape. Leave sufficient service loop in the wires to accommodate removal of the turbine from the tower. Use of an electrical wire strain relief grip is strongly recommended for the downtower transmission wires.

Follow system wiring diagram and run wires to disconnect switch, fuse or circuit breaker and ammeter. If a stop switch is utilized (highly recommended) turn switch to OFF until all connections are completed.

6-2 Mounting on Tower

After wires are connected to Air X, route the wires down the tower and slide the turbine yaw over tower top. After the yaw is completely lowered onto tower top, lift the yaw approximately 1/8 inch (3 mm) to 1/4 inch (6 mm) so that the only contact between the yaw and tower top is through the rubber isolation pad. This will reduce sound and vibration transmission to the tower.

Once the yaw is positioned on the tower, secure the yaw clamp screws using the supplied 5/32 inch hex key wrench. Torque to 5 ft – lbs (6.8 Nm).

If blade/hub assembly is not already installed on turbine, it may be installed now. Position the 5/8-18 nut in the hexagonal detent at the center of the hub. Coat the shaft threads and blade hub bore with Tef-Gel and “spin” the hub completely onto the turbine alternator shaft. Fully tighten hub to 50 lb-ft by inserting a 5/16 inch hex key wrench in the turbine alternator shaft and attempting to turn the shaft while holding the blades. Caution, blades are sharp.

Snap the nosecone into position over the outside edges of the blade hub. Make sure all three edges of the nosecone snap over the edge of the blade hub. After installation tug on the nosecone to make sure it is securely attached.



IMPORTANT: Tef-Gel is a corrosion inhibitor and is especially important in marine applications.

6-3 Final Connections

Before making final connections to the batteries, make sure circuit breakers and stop switch are in the OFF position. Attach wires to battery; red to positive battery terminal and black to negative battery terminal.



WARNING: If the battery connections are reversed, Air X's electronics will be damaged. The polarity of Air X's wires may be checked by connecting a voltmeter to the wires and spinning the rotor by hand.

Complete battery connections and close the disconnect switch and circuit breakers; move the stop switch to the on position (see page 20). When the power is first switched on, the Air X LEDs will illuminate for 2 sec., go off for 2 sec. and then illuminate for 4 sec. to indicate that the internal controller recognizes battery is connected and voltage is within operating range. If there is available wind and Air X starts charging the batteries, the LED remains illuminated.

The installation is now complete.

