



**NEUTRAL TO GROUND
SWITCHING IN RV &
MARINE APPLICATIONS**

Excerpt from Inverter
Charger Series Manual

BY:
VIJAY SHARMA
ENGINEER

NEUTRAL TO GROUND SWITCHING IN RV & MARINE APPLICATIONS

1.0 GENERAL

As explained in the previous *Section 6: Grounding System and Lightning / Ground Fault Protection*, for safety against damage during lightning strike, a Single Point Grounding System is specified in the NEC Code.

Further, the Neutrals of the 3-Wire AC Distribution System (Hot, Neutral, Ground) are required to be bonded to a single Earth Ground Point for safety purposes. If the Neutrals of different components in the system are bonded to the Earth Ground at different points, a voltage difference may develop between the Neutrals of the components in the system due to currents flowing in the impedances of the Neutrals. This may cause an electric shock or nuisance tripping of GFCI's. Also, in case of lightning strike / ground fault, damage will be caused to devices grounded to different Earth Ground points

In a boat / RV, the shore power connection is provided from AC Power Distribution System of the Marina / RV Park and hence, the Neutral of the shore power supply is bonded to the Earth Ground only at one point at the AC Power Distribution System of the Marina / RV Park. **Hence, when the boat / RV is accepting power from shore supply, the Neutral of their distribution system should NOT be bonded to the local Boat Ground / RV Chassis Ground.**

Inverter Chargers are used in RV and marine applications for converting DC battery voltage to AC Power and for charging DC batteries when AC power is available from shore power. It consists of an Inverter, a Battery Charger and a Transfer Relay. As long as the external AC input power from shore power is available, it is passed through to the AC loads through the Transfer Relay Section. At the same time, the Battery Charger Section converts the external AC input power from the utility to DC power to charge the DC Battery Source. In case the utility fails, the load is transferred to the inverter. In case shore power / onboard AC power is not available, the Inverter can be used to provide AC power.

As per Code, the Transfer Relay is required to switch both the Line and Neutral conductors during the switching operation.

The Hot and Neutral AC output terminals of the Inverter Charger will be switched either to the two current carrying conductors of the Inverter or to the two current carrying conductors of the shore power (Hot and Neutral).

As required by NEC and UL specification 458, inverter / charger installations in the U.S. that are used in RV or Marine applications should be provided with a "Neutral to Ground Bond Switching Relay" to switch bonding of the Neutral Output Connector of the Inverter Charger as follows:

- When operating as an inverter, the current carrying conductor of the Inverter Section that is connected to the Neutral Out connector of the Inverter Charger should be bonded to the metal chassis of the inverter by the "Neutral to Ground Bond Switching Relay". As the metal chassis of the inverter is bonded to the RV Ground (chassis of the RV) or to the Boat Ground (DC Negative Grounding Bus Bar and the Main AC Grounding Bus Bar are tied together in a boat and this is called the "Boat Ground"), this current carrying conductor of the Inverter Section will become the Grounded Conductor (GC) or the Neutral of the Inverter Section. This meets NEC requirements.
- When in the Pass Through Mode / Utility Mode, the Neutral of the shore power will be connected to the Neutral Out connector of the Inverter Charger. At the same time, the "Neutral to Ground Bond Switching Relay" will un-bond (disconnect) the Neutral Out connector of the Inverter Charger from the chassis of the Inverter Charger. This will ensure that the Grounded Conductor (GC) / Neutral of the shore power is bonded to the Earth Ground at one single point at the location of the AC Power Distribution System of the Marina / RV Park.

In some marine applications, Neutral-to-Ground switching is not required or acceptable. The potential for galvanic corrosion caused by small leakage currents between boats with dissimilar metals is present. The proper and safe ways to prevent this is by using galvanic isolators or include an isolation transformer for the AC input. **Disconnecting the common ground between the AC and DC system could contribute to a hazardous and potentially fatal situation.**

2.0 IMPLEMENTATION OF AC TRANSFER AND GROUND-TO-NEUTRAL BOND SWITCHING IN INVERTER CHARGER SERIES

Fig. 1 explains implementation of AC transfer and Ground to Neutral Bond Switching in the Inverter Charger series.

2.1 The Bi-directional Transformer of the Inverter Charger Series is used as follows:

- Feeds AC output from the Inverter Section to the AC loads when utility / shore power is not available.
- Feeds utility / shore power to the battery charger Section when shore power / utility is available. At the same time the utility / shore power is passed through to the AC load

2.2 Switching of Hot Output (HOT OUT)

- Relays K1 and K4 are rated at 40 A and operate in parallel (effective capacity of 80 A). These are used to switch the Hot Output Connector (HOT OUT) (14) to either the Inverter Section or to the Utility / Shore Power
- When Utility / Shore Power is available, relays K1 and K4 are energized and contact 4 switches over to contact 5. The Bi-directional Transformer operates as a battery charger. The Hot AC input (HOT IN) (9) from the utility / shore power available at contacts 5 switches to the closed contacts 4 which become the Hot Utility / shore power input for the Bi-directional Transformer for battery charging. At the same time, the Hot input from the utility / shore power now available at contacts 4 is passed through to the Hot Out (HOT OUT) (14) for powering the AC loads
- When Utility / Shore Power fails, relays K1 and K4 are de-energized and contacts 4 – 5 are opened (contacts 4 switch over to contacts 3). The Bi-directional Transformer operates as an inverter. Hot AC output from the Bi-directional Transformer connected to contact 4 is fed to the Hot Out (HOT OUT) (14) for powering the AC loads

NEUTRAL TO GROUND SWITCHING IN RV & MARINE APPLICATIONS

2.3 Switching of Neutral to Ground Bonding

- Relays K2 and K3 are also rated at 40 A and operate in parallel (effective capacity of 80 A). These are used to switch the bonding between the Neutral Out Connector (NEU OUT) and the chassis of the Inverter Charger.
- When Utility / Shore Power is available, K2 and K3 are energized and contacts 4 switch over to contacts 5. The Bi-directional Transformer works as a battery Charger. AC input Neutral (NEU IN) (10) from the shore power which is available at contacts 5 switches to contacts 4 and from there it is fed to the Neutral input of the Bi-directional Transformer for battery charging. At the same time, the Neutral Input (NEU IN) (10) is passed through to the Neutral Out (NEU OUT) (13) through contacts 4 for powering the load.
- As contact 4 and 3 are open, The Neutral Out (NEU OUT) is disconnected from the chassis of the Inverter Charger. Hence, the Neutral out (NEU OUT) (13) will be bonded to the Earth Ground at a single point at the location of the AC Power Distribution System of the Marina / RV Park. (If the Neutral Out (NEU OUT) (13) remained bonded to the chassis of Inverter Charger, the Neutral Out (NEU OUT) (13) would have created a second Neutral to Earth Ground Bond at the boat / RV because the chassis of the Inverter Charger is bonded to the RV chassis / Boat Ground) which is not desirable).
- When Utility / Shore Power is removed, K2 and K3 are de-energized and contacts 4 switch over to contacts 3. The Bi-directional Transformer operates as an inverter. One of the current carrying conductors of the Bi-directional Transformer that is connected to contacts 4 is now bonded to the chassis of Inverter Charger through contacts 3. This current carrying conductor of the Bi-directional Transformer connected to contacts 4 now becomes a Grounded Conductor (GC) or Neutral of the Inverter Section. At the same time, the Neutral out of the Bi-directional Transformer connected to contacts 4 is connected to the Neutral Out (NEU OUT).

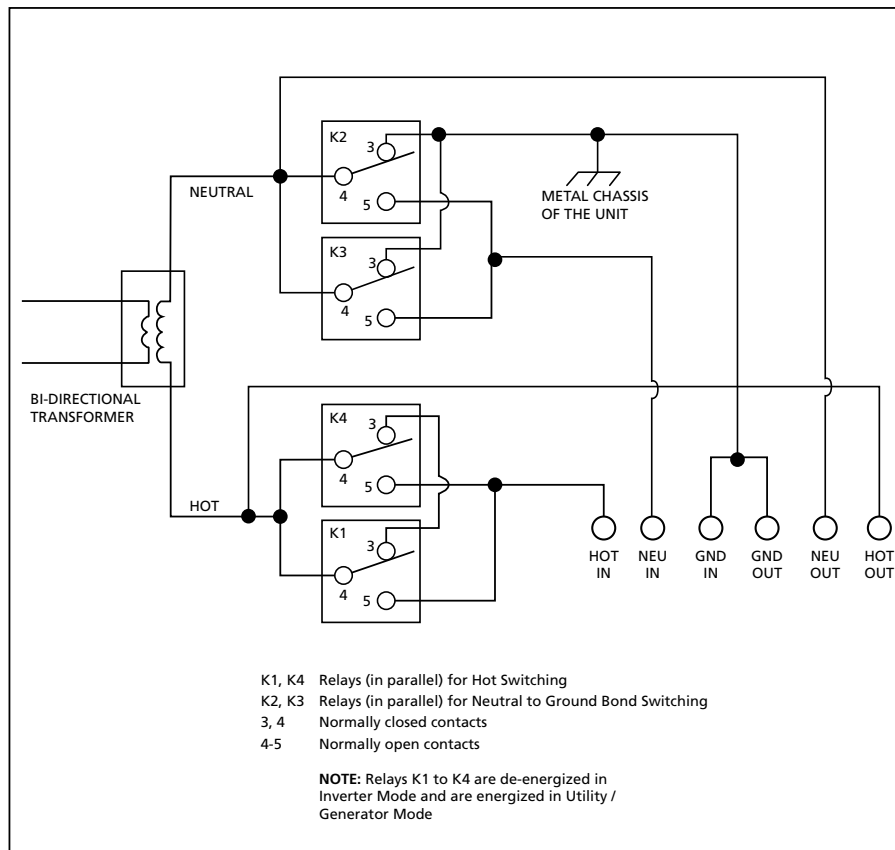

Fig. 1 Operation of Transfer Relay and Neutral to Ground Bond switching in Inverter Charger series

For more information, visit: www.samlexamerica.com