

FUSE1: BY "BUSSMANN" GDA-6.3A
BY "LITTLEFUSE" 21806.3

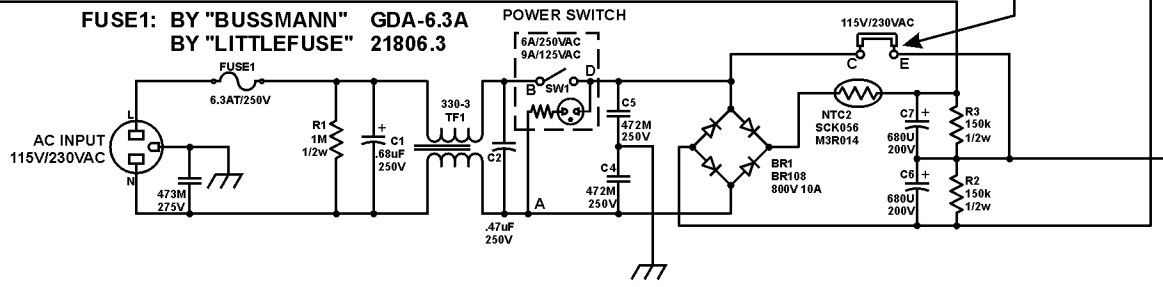

SAMLEX AMERICA, INC.
PHONE: (604) 525-3836
FAX: (604) 525-5221

SCHEMATIC: SEC-1223

Redrawn by: Tom Hammond, NØSS v1.0 25 Nov 2004
Rev. 1.1, 17 Jan 2008, to incl. C24 across output.

SAMLEX AMERICA, INC.

PHONE (604) 525-3836

FAX

(604) 525-5221

BILL OF MATERIALS - SEC-1223

Parts Name	Specification	Q'ty	Location
PCB	SEC-1223	1	
	SQM 5% 5W 120R	1	R12
Resistor	CR 5% 1/2W 1K	1	R33
Resistor	CR 5% 1/2W 8.2	1	R31
Resistor	CR 5% 1/2W 150K	2	R2, R3
Resistor	CR 5% 1.2W 270K	2	R6, R9
Resistor	CR 5% 1.2W 1M	1	R1
Resistor	CR 5% 1/4W 4.3	2	R5, R8
Resistor	CR 5% 1/4W 270	1	R18
Resistor	39	2	R4, R11
Resistor	1K	2	R13, R15
Resistor	1.5K	2	R17, R29
Resistor	2K	1	R22
Resistor	2.2K	1	R20
Resistor	2.7K	2	R7, R10
Resistor	3.9K	2	R14, R16
Resistor	5.1K	2	R21, R25
Resistor	10K	3	R24, R30, R34
Resistor	12K	1	R28
Resistor	27K	1	R19
Resistor	39K	1	R27
Resistor	56K	1	R26
Resistor	68K	1	R23
Jumper Wire	0.8M.M	4 (5)	J1,2,3,4,7
Jumper Wire	1.0M/M	1	J8
Jumper Wire	1.2M/M	2	J5, J6
Metallized Cap.	(X Cap.) .68uF/250V	1	C1
Metallized Cap.	(X Cap.) .47uF/250V	1	C2
Metallized Cap.	225K/250V	1	C10
Metallized Cap.	223K/400V	2	C25, C26
Multilayer Cap.	102/50V (NP0)	2	C14, C15
Multilayer Cap.	103/50V (X7R)	2	C16, C17
Multilayer Cap.	104/50V (Z5U)	2	C19, C24
Ceramic Cap.	102M/1KV	1	C11
Ceramic Cap.	103Z/1KV	1	C20
Ceramic Cap.	(Y Cap.) 222M/400V(AC)	2	AC Socket
Ceramic Cap.	(Y Cap.) 472M/250V(AC)	1	C4, C5
Electrolytic Cap.	2200uF/25V (16*25)	3	C21, C22, C23
Electrolytic Cap.	330uF/35V (10*18)	1	C13
Electrolytic Cap.	4.7uF/50V (5*11)	1	C18
Electrolytic Cap.	10uF/50V (5*11)	3	C8, C9, C12

Electrolytic Cap.	600uF/200V (25*35)	2	C6, C7
N.T.C	SCK056 / M3R014	1	NTC 2
Diode	HER102	5	D1, 4, 5, 6, 10
Diode	FR107	2	D2, D3
Diode	1N4148	3	D7, D8, D9
Diode	BYV72E-200 (Philips)	1	SD1
Transistor	2SC2625 (Fuji) / 2SC5071 (Sanken)	2	Q1, Q2
Transistor	2SC1815	2	Q3, Q4
Transistor	PN2222A	1	Q5
IC	KA7500B (Samsung) or TL494IN (Motorola)	1	IC1
Variable Resistor	500 Ohm (501)	1	VR1
Variable Resistor	1K (102)	1	VR2
Transformer	1223-1 (ETD-39)	1	T2
Transformer	330-2 (EE-19L)	1	T1
Transformer	330-3 (ET28)	1	TF1
Transformer	23uH	1	L1
Transformer	1223-3 (R6*20)	1	L2
Bridge Diode	BR108 800V / 10A	1	BR1
Fuse	(UL App.) 6.3AT/250V (5*20)	1	FUSE1
Fuse Holder	5*20 (7mm)	2	FUSE1
Fan	TYM6020BH (12V)	1	Bottom Case
Spade Terminal (M)	P850	4	L N + -
Dual Binding Post	WTN-1047	1	Bottom Case
Housing	Upper Cover	1	
Housing	Bottom Cover	1	
Temperature Switch	OP62/100C/080m/m	1	TH-2
Temperature Switch	SK1/070/05/100	1	TH-1
Power Switch	R992KDET2F	1	Bottom Case
Power Switch	R-301 / SS-7B	1	Bottom Case
Power Cord	America 2 sides/0.75/2M	1	Accessory
Wire	1.8*20M/M	3	J8, J9, J10
Rubber Foot	T211308	4	Bottom Case
Rubber Foot	HU-12	2	C4, C5
Heat Sink	P001 (18M/M)		Lock BR1
Heat Sink	L Type 25*96*8 4 Holes	1	Bottom Case
Fixing Metal	73009-A	1	Heat Sink
Rubber Tube	14*25M/M	2	Back of Q1, Q2
Rubber Tube	TO-3P	1	Back of SD1
Cable Tie	YJ-98	2	A.B.D.

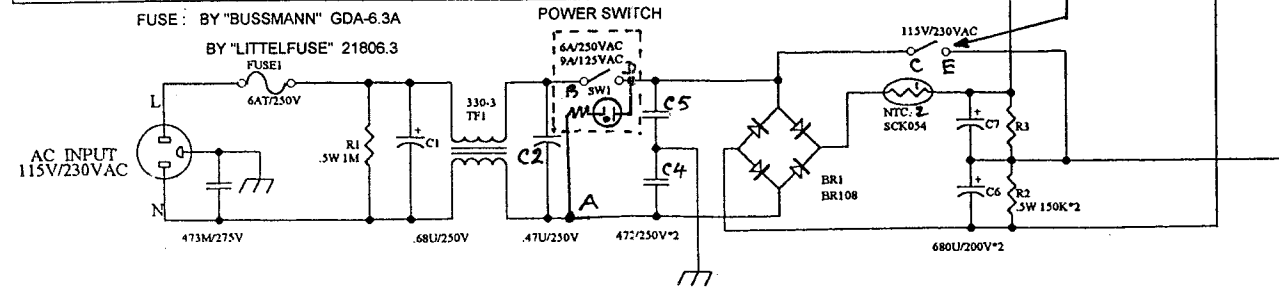
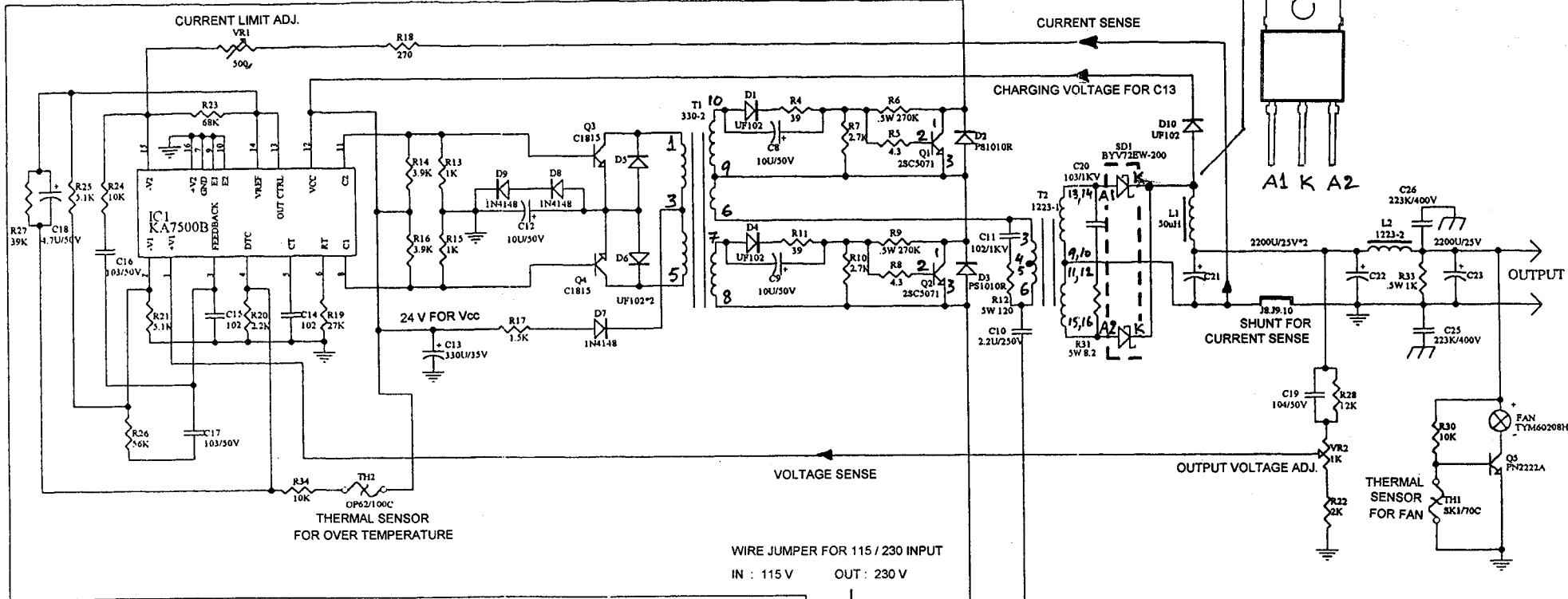
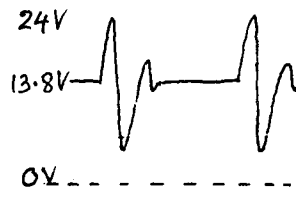
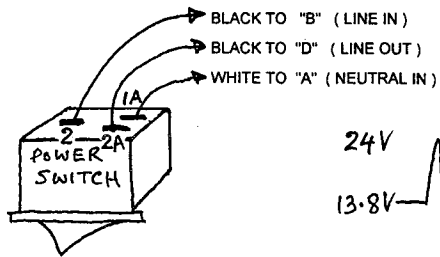
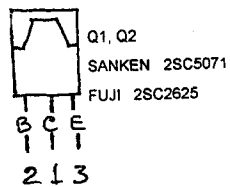
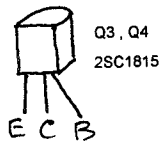

SAMLEX AMERICA, INC.
PHONE : (604) 525-3836
FAX : (604) 525-5221
SCHEMATIC : SEC-1223

SAMLEX AMERICA, INC.

PHONE (604) 525-3836

FAX

(604) 525-5221

BILL OF MATERIALS - SEC-1223

Parts Name	Specification	Q'ty	Location
P.C.B	SEC12-23	1	
	SQM 5% 5 W 120R	1	R12
Resistor	CR 5% 1/2W 1K	1	R33
Resistor	CR 5% 1/2W 8.2	1	R31
Resistor	CR 5% 1/2W 150K	2	R2.R3
Resistor	CR 5% 1/2W 270K	2	R6.R9
Resistor	CR 5% 1/2W 1M	1	R1
Resistor	CR 5% 1/4W 4.3	2	R5.R8
Resistor	CR 5% 1/4W 270	1	R18
Resistor	39	2	R4.R11
Resistor	1K	2	R13.R15.
Resistor	1.5K	2	R17.29
Resistor	2K	1	R22
Resistor	2.2K	1	R20
Resistor	2.7K	2	R7.R10
Resistor	3.9K	2	R14.R16.
Resistor	5.1K	2	R21.R25
Resistor	10K	3	R24.30.34
Resistor	12K	1	R28
Resistor	27K	1	R19
Resistor	39K	1	R27
Resistor	56K	1	R26
Resistor	68K	1	R23
Jumper Wire	0.8M/M	4	J1.2.3.4.7
Jumper Wire	1.0M/M	1	J8
Jumper Wire	1.2M/M	2	J5.6
Metallized Cap.	(X Cap.) .68UF/250V	1	C1
Metallized Cap.	(X Cap.) .47 UF/250V	1	C2
Metallized Cap.	225K/250V	1	C10
Metallized Cap.	223K/400V	2	C25.C26
Multilayer Cap.	102/50V (NPO)	2	C14.15
Multilayer Cap.	103/50V (X7R)	2	C16.C17
Multilayer Cap.	104/50V (Z5U)	2	C19.24
Ceramic Cap.	102M/1KV	1	C11
Ceramic Cap.	1037./1KV	1	C20
Ceramic Cap.	(Y Cap.) 222M/400V(AC)	2	AC Socket
Ceramic Cap.	(Y Cap.) 472M/250V(AC)	2	C4.5
Electrolytic Cap.	2200UF/25V (16*25)	3	C21.22.23
Electrolytic Cap.	330UF/35V (10*18)	1	C13
Electrolytic Cap.	4.7UF/50V (5*11)	1	C18
Electrolytic Cap.	10UF/50V (5*11)	3	C8.9.12

Electrolytic Cap.	680UF/200V (25*35)	2	C6.C7
N.T.C	SCK056 / M3R014	1	NTC 2
DIODE	HER102	5	D1.4.5.6.10
DIODE	FR107	2	D2.D3
DIODE	IN4148	3	D7.8.9
DIODE	BYV72EW-200 (PHILIPS)	1	SD1
	FUJI ↘ ↙ SANKEN		
Transistor	2SC2625 / 2SC5071	2	Q1.Q2
Transistor	2SC1815	2	Q3.Q4
Transistor	PN2222A	1	Q5
IC	KA7500B (SAMSUNG) OR TL494 IN (MOTOROLA)	1	IC1
Variable Resistor	500 ohm (501)	1	VR1
Variable Resistor	1K (102)	1	VR2
Transformer	1223-1 (ETD-39)	1	T2
Transformer	330-2 (EE-19L)	1	T1
Transformer	330-3 (ET28)	1	TF1
Transformer	23UH	1	L1
Transformer	1223-2 (R6*20)	1	L2
Bridge Diode	BR108 800V, 10A	1	BR1
Fuse	(UL App.) 6.3AT/250V (5*20)	1	FUSE1
Fuse Holder	5*20 (脚距7MM)	2	FUSE1
Fan	TYM6020BH (12V)	1	Bottom CASE
Spade Terminal (male)	P850	4	L.N.+,-
Dual Binding Post	WTN-1047	1	Bottom CASE
Housing	Upper COVER	1	
Housing	Bottom CASE	1	
Temperature Switch	OP62/100C/080MM	1	TH-2
Temperature Switch	SK1/070/05/100	1	TH-1
Power Switch	R992KDET2F	1	Bottom Case
Power Socket	R-301 / SS-7B	1	Bottom Case
Power Cord	America 2 sides/0.75/2M	1	Accessory
Wire	1.8*20MM	3	J8.9.10
Rubber Foot	T211308	4	Bottom Case
Rubber Tube	HU-12	2	C4.5
Heat Sink	P001 (18MM)		Lock BR1
Heat Sink	L Type 25*96*8 4 Holes	1	Bottom Case
Fixing Metal	73009-A	1	Heat Sink
Rubber Tube	14*25MM	2	Back of Q1, Q2
Rubber Sheet	TO-3P	1	Back of SD1
Cable Tie	YJ-98	2	A.B.D

SAMLEX SEC-1223 12VDC 23A SWITCHING P/S 120VAC TO 220VAC CONVERSION

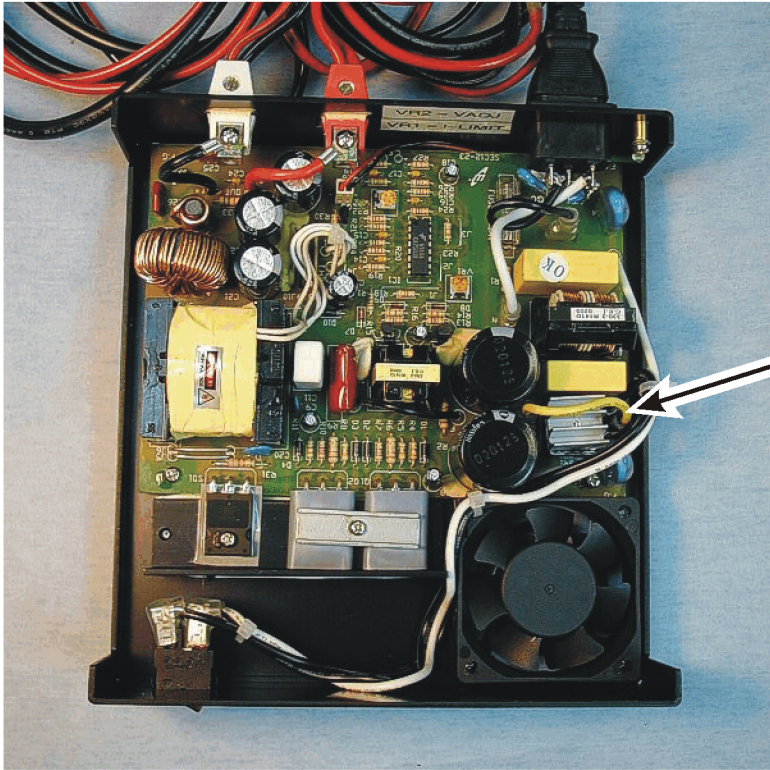

FOR 220VAC OPERATION,
LIFT ONE END OF THE
YELLOW JUMPER RUNNING
BETWEEN PINS C & E ON
THE PC BOARD.

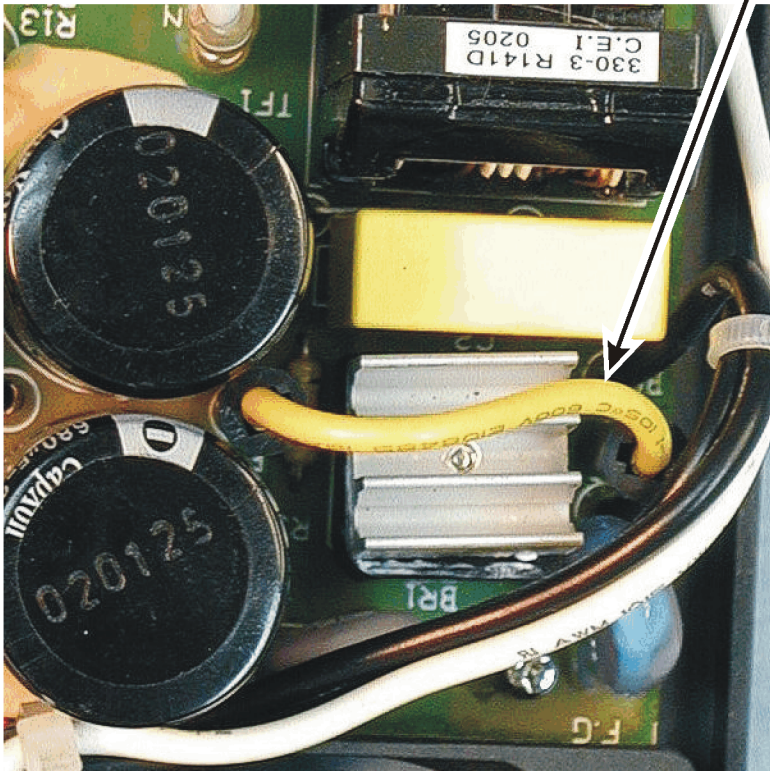

VOLTAGE-MODE PWM CONTROLLER

The KA7500B is used for the control circuit of the pulse width modulation switching regulator. The KA7500B consists of 5V reference voltage circuit, two error amplifiers, flip flop, an output control circuit, a PWM comparator, a dead time comparator and an oscillator. This device can be operated in the switching frequency of 1 KHz to 300 KHz.

FEATURES

- Internal regulator provides a stable 5V reference supply trimmed to 1 %
- Uncommitted output TR for 200mA sink or source current
- Output control for push-pull or single-ended operation
- Variable duty cycle by dead time control (pin 4)
- Complete PWM control circuit
- On-chip oscillator with master or slave operation
- Internal circuit prohibits double pulse at either output

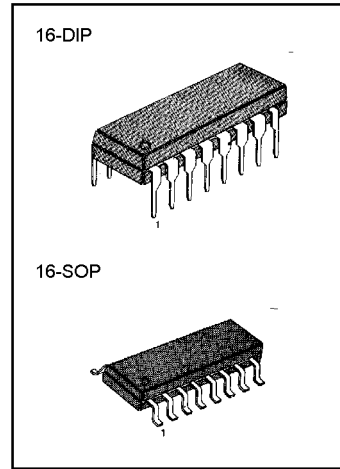

ORDERING INFORMATION

Device	Package	Operating Temperature
KA7500B	16 DIP	0 ~ + 70°C
KA7500BD	16 SOP	0 ~ + 70°C

BLOCK DIAGRAM

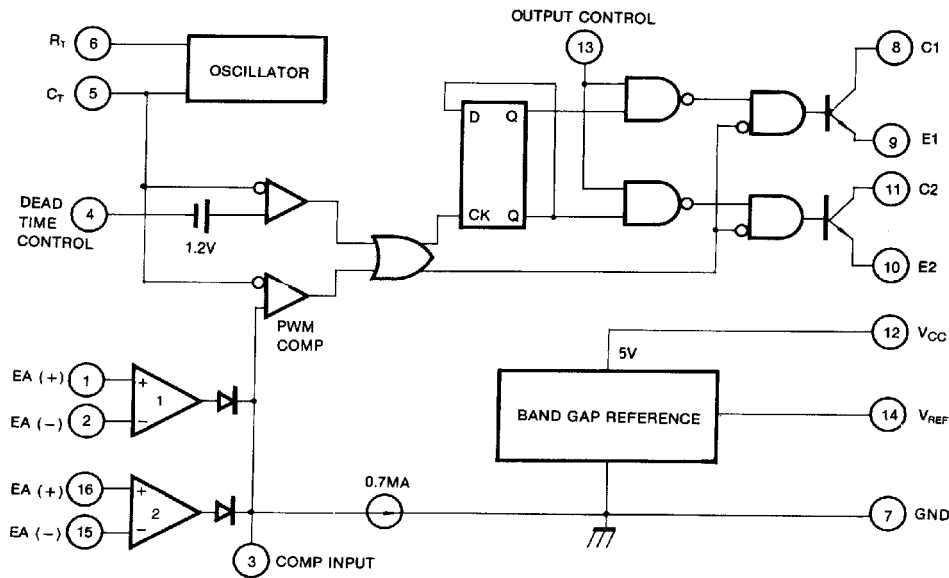

ABSOLUTE MAXIMUM RATINGS

Characteristic	Symbol	Value	Unit
Supply Voltage	V_{CC}	42	V
Collector Supply Voltage	V_C	42	V
Output Current	I_O	250	mA
Amplifier Input Voltage	V_{IN}	$V_{CC} + 0.3$	V
Power Dissipation ($T_A = 25^\circ\text{C}$)	P_D	1 (KA7500B) 0.9 (KA7500BD)	W
Operating Temperature Range	T_{OPR}	0 ~ +70	$^\circ\text{C}$
Storage Temperature Range	T_{STG}	-65 ~ + 150	$^\circ\text{C}$

ELECTRICAL CHARACTERISTICS

($V_{CC} = 20\text{V}$, $f = 10\text{KHz}$, $T_A = 0^\circ\text{C}$ to +70 $^\circ\text{C}$, unless otherwise specified)

Characteristic	Symbol	Test Conditions	Min	Typ	Max	Unit
REFERENCE SECTION						
Reference Output Voltage	V_{REF}	$I_{REF} = 1\text{mA}$	4.75	5.0	5.25	V
Line Regulation	ΔV_{REF}	$V_{CC} = 7\text{V to } 40\text{V}$		2.0	25	mV
Temperature Coefficient of V_{REF}	$\Delta V_{REF}/\Delta T$	$T_A = 0^\circ\text{C to } 70^\circ\text{C}$		0.01	0.03	%/ $^\circ\text{C}$
Load Regulation	ΔV_{REF}	$I_{REF} = 1\text{mA to } 10\text{mA}$		1.0	15	mV
Short-Circuit Output Current	I_{SC}	$V_{REF} = 0$	10	35	50	mA
OSCILLATOR SECTION						
Oscillation Frequency	f	$C_T = 0.01 \mu\text{F}$, $R_T = 12\text{K}\Omega$		10		KHz
Frequency Change with Temperature	$\Delta f/\Delta T$	$C_T = 0.01 \mu\text{F}$, $R_T = 12\text{K}\Omega$			2	%
DEAD TIME CONTROL SECTION						
Input Bias Current	I_{BIAS}	$V_{CC} = 15\text{V}$, $0\text{V} < V_4 < 5.25\text{V}$		-2.0	-10	μA
Maximum Duty Cycle	$D_{(MAX)}$	$V_{CC} = 15\text{V}$, $V_4 = 0\text{V}$ $O.C \text{ Pin} = V_{REF}$	45			%
Input Threshold Voltage	V_{ITH}	Zero Duty Cycle		3.0	3.3	V
		Max. Duty Cycle	0			
ERROR AMP SECTION						
Input Offset Voltage	V_{IO}	$V_3 = 2.5\text{V}$		2.0	10	mV
Input Offset Current	I_{IO}	$V_3 = 2.5\text{V}$		25	250	mA
Input Bias Current	I_{BIAS}	$V_3 = 2.5\text{V}$		0.2	1.0	μA
Common Mode Input Voltage	V_{CM}	$7\text{V} < V_{CC} < 40\text{V}$	-0.3		V_{CC}	V
Open-Loop Voltage Gain	G_{VO}	$0.5\text{V} < V_3 < 3.5\text{V}$	70	95		dB
Unit-Gain Bandwidth	BW			650		KHz

ELECTRICAL CHARACTERISTICS

($V_{CC} = 20V$, $f = 10KHz$, $T_A = 0^\circ C$ to $+70^\circ C$, unless otherwise specified)

Characteristic	Symbol	Test Conditions	Min	Typ	Max	Unit
PWM COMPARATOR SECTION						
Input Threshold Voltage	V_{ITH}	Zero Duty Cycle		4	4.5	V
Input Sink Current	I_{SINK}	$V_S=0.7V$	-0.3	-0.7		mV
OUTPUT SECTION						
Output Saturation Voltage Common Emitter	$V_{CE(SAT)}$	$V_E = 0, I_C = 200mA$		1.1	1.3	V
Common Collector	$V_{CC(SAT)}$	$V_C = 15V, I_E = -200mA$		1.5	2.5	
Collector Off-State Current	$I_{C(OFF)}$	$V_{CC} = 40V, V_{CE} = 40V$		2	100	μA
Emitter Off-State Current	$I_{E(OFF)}$	$V_{CC} = V_C = 40V, V_E = 0$			-100	
TOTAL DEVICE						
Supply Current	I_{CC}	Pin 6 = V_{REF} , $V_{CC} = 15V$		6	10	mA
OUTPUT SWITCHING CHARACTERISTIC						
Rise Time	t_R					
Common Emitter				100	200	nS
Common Collector				100	200	
Fall Time	t_F					
Common Emitter				25	100	nS
Common Collector				40	100	

TYPICAL APPLICATION

PLUSE WIDTH MODULATED STEP-DOWN CONVERTER

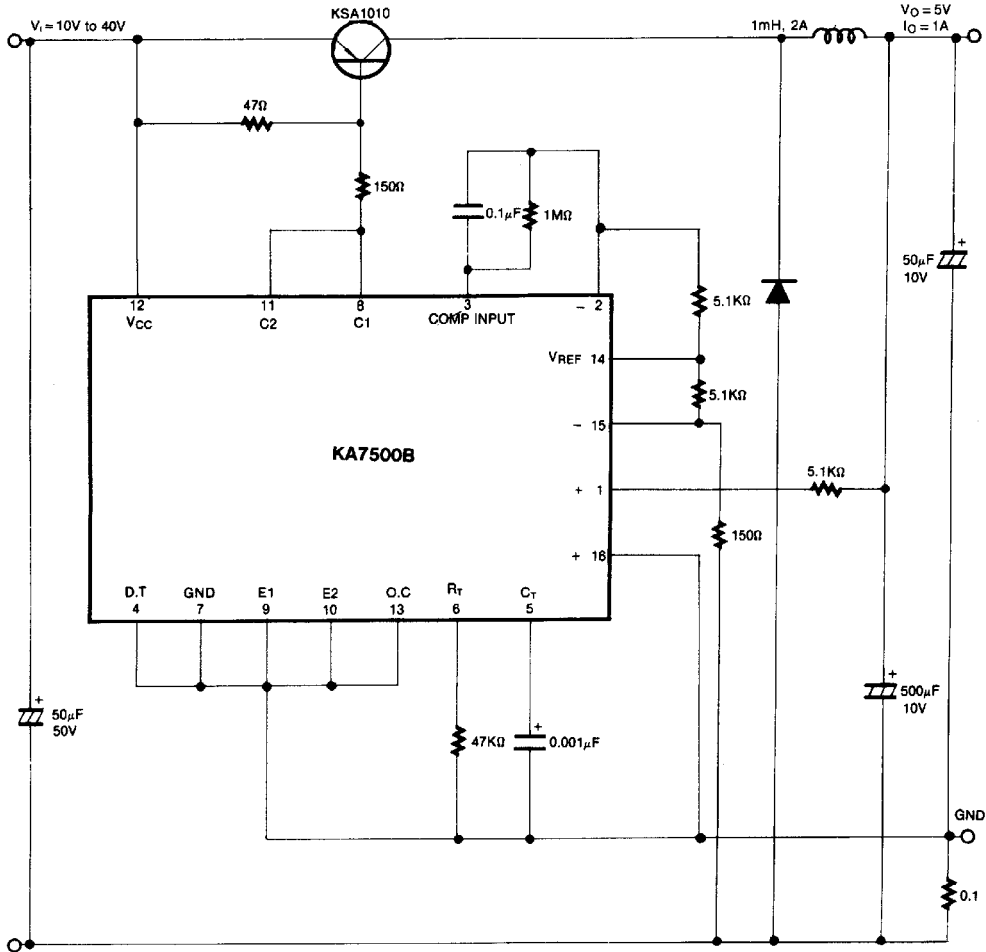

Dimensions in Millimeters

