



## 13ULNA

### ***SPECIFICATIONS***

Noise Figure:	< 0.7 dB
Gain:	> 15 dB
Frequency Range:	2300 - 2450 MHz
Input Voltage:	7 - 16 VDC
Current Drain:	< 25 mA.

### **DESCRIPTION:**

The 13ULNA is a low noise amplifier designed by W5LUA and Down East Microwave Inc. using the latest PHEMPT technology. This LNA was designed for receive only purposes including Phase IIID, EME, and other standard weak signal reception between 2300 and 2450 MHz. The LNA is assembled in a weatherproof enclosure and has the option of two connector types, either SMA or Type "N" that is specified when ordering. This new design can be biased either through the coax or through a external DC feed through connector in its standard form. There is no need to specify. Custom models are available to cover band segments from 2100 - 2500 MHz.

### **INSTALLATION and USE:**

Depending on your application, the LNA may be installed anywhere in your system to increase gain. To maintain or improve the systems noise figure requires the LNA to be installed as close to the systems antenna as possible. If you are using this LNA in a transceive system with transmit bypass relays, be sure of their isolation characteristics and transmit power handling capabilities before transmitting. Use only interconnecting cables and adapters that are rated for use at or above 2.5 GHz. Inadequate cabling or cables with poor shielding may cause system instabilities, signal loss, or undesirable intermittent operation.

The connector marked **INPUT**, is to be connected to the antenna. The **OUTPUT** is connected to the receiver. The output connector accepts only DC bias between +7 and +16 volts. This may be supplied by the receiver or a DC power inserted located between the LNA output and the receiver input. If using coaxial transfer relays in the system with DC bias on the coax, be sure that shorting type relays are not used in the receive path in a way that the DC is connected to ground when the LNA is switched out of line.

The input circuit of the LNA is DC shorted for static protection. This a useful feature when using antennas such as a dish with a wave guide fed or a helical type antenna that are DC open to ground. This DC short will protect the LNA when it is installed in a remote location but will degrade the noise figure by 0.1dB. The LNA will not withstand a direct lightning hit. Other precautions will need to be made for such an instance.



**OPERATING:**

Expected performance should be overall improvement in gain and noise figure of the receive system with the LNA correctly installed. The proper installation of a LNA becomes more and more important at these frequencies and because of the developments in the ISM bands, interference will increase in the future. The gain bandwidth of the LNA design is wide to obtain a low noise figure. Therefore, certain conditions may cause overloading of your receiver producing intermodulation. It is always suggested to use adequate filtering between gain stages and to practice gain management by not cascading amplifiers to solve system noise problems. Use of directional antennas will also increase desired signals and aid in elimination of undesired signals in the 13cm band.

For use in EME or weak signal type systems, the elimination of the shorted line on the input circuit may be desired. If so, open the lid by removing the 4 screws, and with a sharp knife, cut the printed inductor line as close to the RF input circuit as possible. This may only slightly improve the noise figure and may not be worth giving up the static protection in a tropo only system. If you are not biasing the LNA through the coax, eliminating the printed inductor on the output connector will only net you a maximum of 0.1dB gain.

If you are biasing the LNA through the coax, there is no need to insulate the DC feed through connector. There will be no measurable voltage on the Feed through and it will not disable the LNA if shorted accidentally.

**COMPONENT LIST**

All resistors are 1206 size chips unless indicated. The white band is positive on the Tantalum chip capacitors. All other capacitors are various sizes.

C1 0.1µF	C6 10.0 µF Tant.	CR3 MMBD914	R1 15	R5 1K pot
C2 8.2 ρF ATC	C7 0.1µF	CR4 MMBD914	R2 51	R6 100
C3 0.1µF	C8 8.2 ρF ATC	IC1 7660 SMD	R3 5.1K	VR1 78L05
C4 10.0 µF Tant.	C9 8.2 ρF ATC	L1 0.4" Strand	R4 51	PC Board
C5 1.0 µF Tant.	C10 8.2 ρF ATC	Q1 ATF36077		

# 13ULNA SCHEMATIC

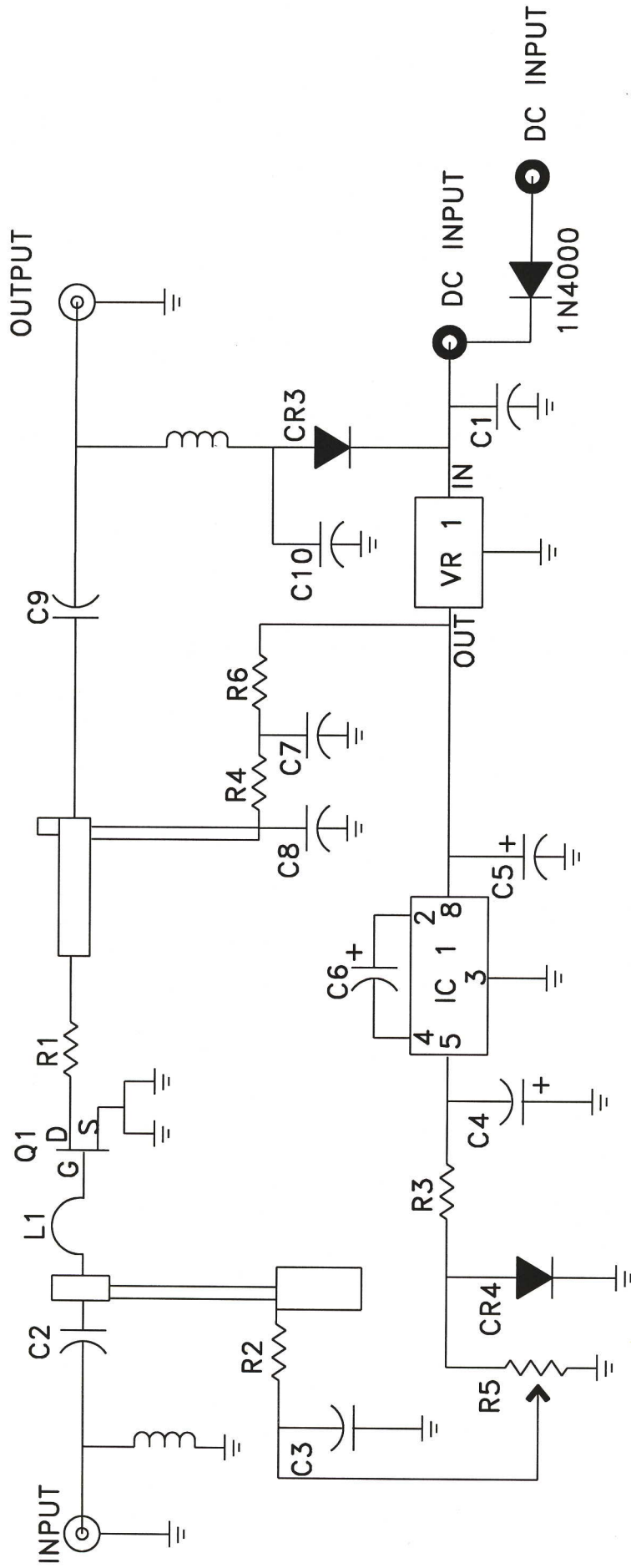

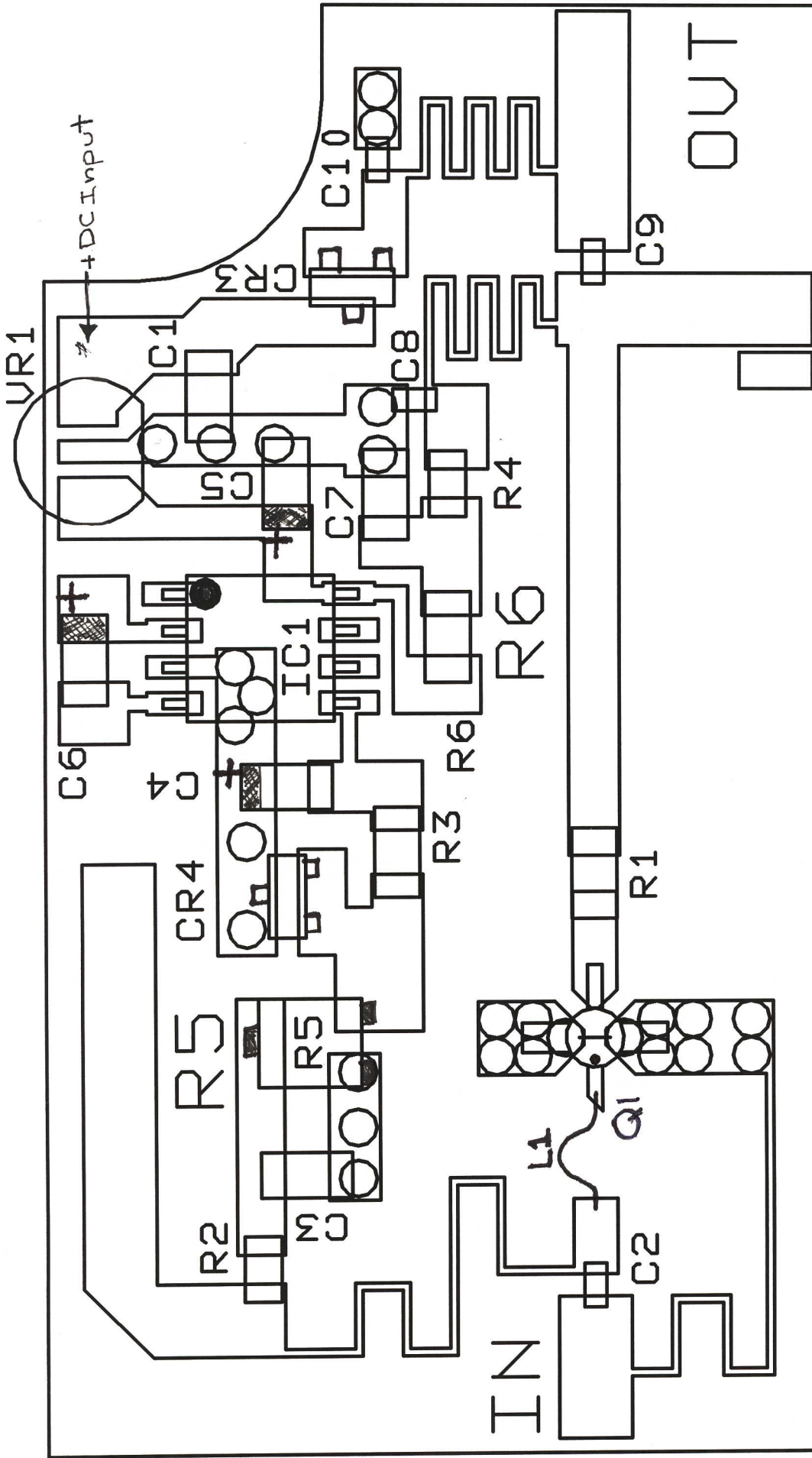

WSLUA/DEMI  
13ULNA

+