

**DEM L5ULNAK or CK**  
**5.7 GHz. PHEMT LNA amplifier Kit / Complete Kit assembly guide**

**SPECIFICATIONS**

Noise Figure:	< 0.7 dB
Gain:	> 14 dB
Frequency Range:	5600 - 5850 MHz
Input Voltage:	7 - 16 VDC

**Description:**

The L5ULNAK or CK is a Kit or Complete Kit of our L5ULNA low noise amplifier designed by W5LUA and Down East Microwave Inc. The complete kit comes with a machined electro plated enclosure, the PC board kit, and connectors of choice (SMA or “N”). The Kit version is the PCB and components only. The LNA may be installed anywhere in your system but it is an receive only preamplifier and requires coaxial relay switching for transceive operation.

Before starting assembly, read through the entire assembly guide. Review all of the assembly and test procedures and inventory the components. If you have the CK, sort the hardware and trial fit any of the hardware if a screw or connector hole looks questionable. When you are sure of all of the kit contents begin the assembly with confidence and have fun!

**Begin Assembly:**

The document assumes that the complete kit version is being assembled. If you have the board kit only, use only what pertains to its assembly.

Start by fitting the circuit board into the enclosure. The board should drop in and fall out when flipped upside down. If it “Sticks”, sometimes the corners of the board are not cut correctly or have excess material left over from the machine cut. Simply trim to fit. When in place, the 5 mounting holes should line up. The RF connector pin holes should also center on the input and output RF circuit traces

The board assembly is easy but follow standard ESD precautions when handling components. Use a grounded solder iron if possible. Be sure you are discharged of static before handling IC1 or Q1. All other components are ESD resilient but are attached to the circuitry which contains IC1 and Q1.

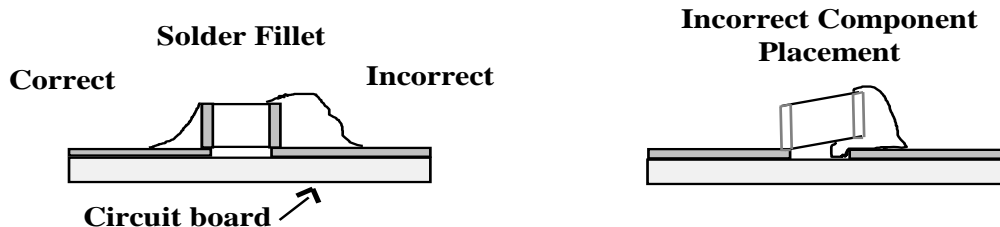
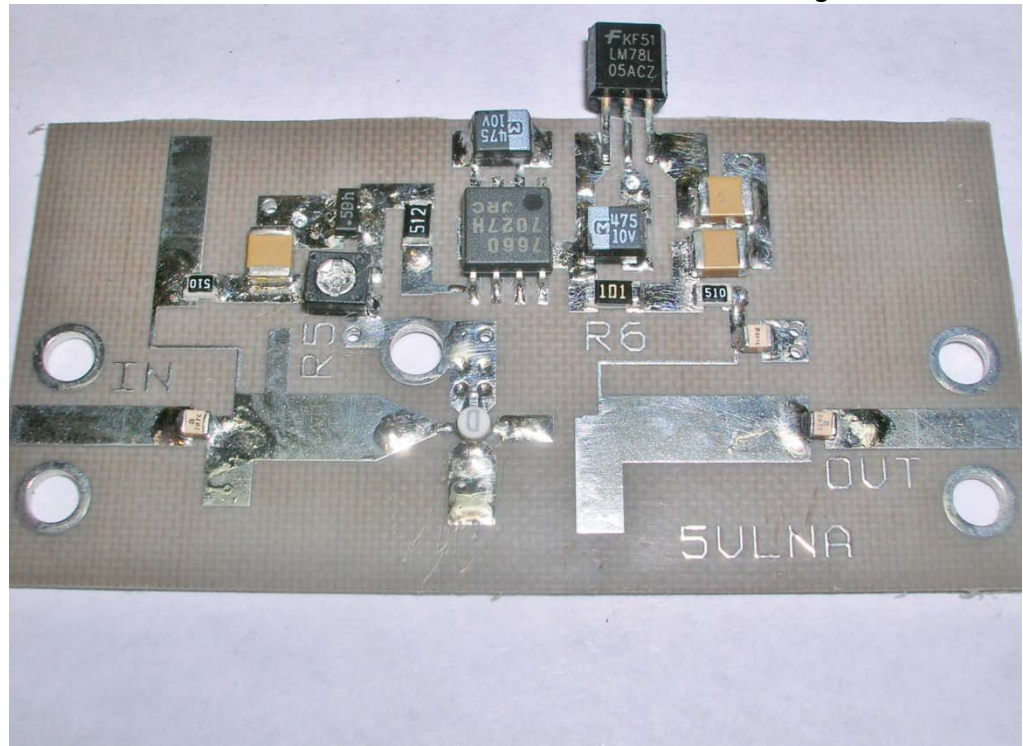

**FIGURE 1.**

After reviewing Figure 1 and referring to the component placement diagram and the components list, begin to assemble the PCB by installing IC1 first. Pin 1 is marked on the placement diagram. Solder pin 3 first. This is the ground pin. Check for alignment of the other pins and if OK, proceed to solder the other 7 pins in any order. Check for solder shorts with ohm meter. Next attach Q1. The leads of Q1 may be “Pre” solder tinned. Follow the

marking shown on the component placement, align and solder the drain lead first (the output lead or the lead connected to R1). Check the alignment and then solder the source leads (the 2 leads on the ground plane with the via holes). You may find the source leads difficult to solder because the heat from the iron is sunk away through the via holes to the ground plane. Solder the gate lead last. Install all other components on the circuit board in any order except R1, C4, and VR1. All ground connections have multiple ground vias and may be difficult to solder. Solder multiple connection pads last. Be sure to check the polarity of C4, C5, and C6. It is indicated on the component placement guide.

When complete, check for missing solder, missing components, or shorts. Feel free to use a ohmmeter for testing any connection. To Test Q1 with a ohm meter, verify that the drain lead is not shorted to the source. It should be between 6 and 15 ohms to ground. Be sure to Zero your meter first. The gate should be in the Kilo-ohm region. Now install VR1 as shown in figure 2. VR1 is installed by cutting the leads short and soldering them to the circuit laying flat with the labeling facing up. Then after soldering, bend the package up to depict the component placement document or in Figure 3.



**FIGURE 2.**

**Hardware Assembly:**

The mechanical fit is very important to the function of this LNA. This is the reason for trial fitting the board before assembly. Trimming the PC board now would crack some installed components. BUT—some solder may have wicked through the plated through vias. The bottom of the board needs to be flat. You can solder wick any excess solder or file smooth with a small fine file. Just be sure the bottom is flat!

The board again should drop in the enclosure and line up with the mounting holes. Mount the board with the 3-48 Phillister head screws. Then install C4. It is a very awkward fit but it will work. Be sure of the polarity. (See Fig 3) Next install the RF connectors first by cutting the Teflon back to 0.200" total length with the center pin extending 0.050" more. Be sure to file any sharp edge off of the center pin after cutting. OR—you can eyeball the lengths using the enclosure wall as a guide. Insert both RF connectors in the holes on the enclosure being careful that the center



pin does not catch the circuit board on the way in. The pin should rest on top of the circuit. Be sure that the connector flange is flush with the enclosure. If not, the Teflon is too long. Re-trim if needed. After fitting, if you require weatherproofing, you may apply a sealant before bolting the connectors in place with the 4-40 x 1/4" screws.

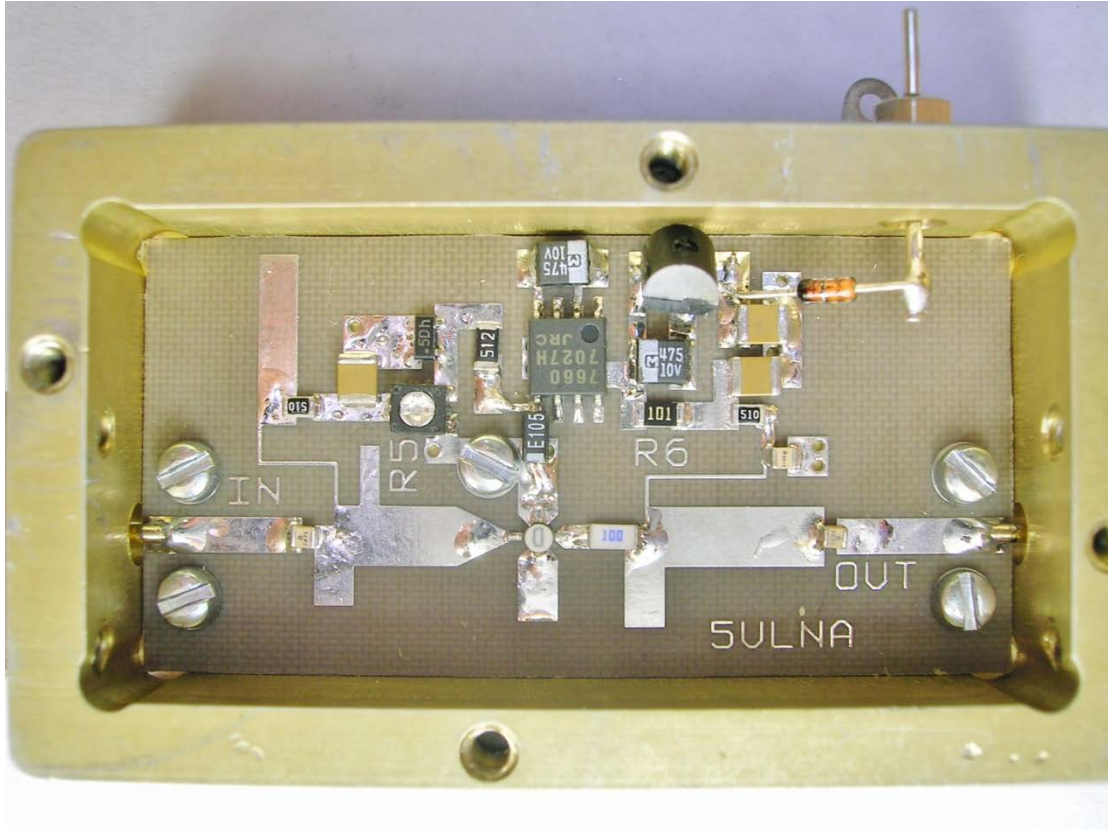

**Warning:** Do not tighten any board or connector screws after the center pins are soldered! This may tear the center pin from the circuit board. Be sure that all screw are absolutely tight before soldering! Solder the two center pins when ready. They should be on center of the circuit board trace.

**FIGURE 3.**

Install the 8-32 Feed-thru connector and ground lug (see Figure 3) in the remaining hole of the enclosure. Again if you want a weatherproof enclosure, apply some sealant to the connector before installing. Connect the 1N914 type diode between the DC feed-thru connector and the point on the component placement labeled "+DC Input". This is a reverse polarity protection diode.

**Pre-Testing and Final Assembly:**

Preliminary testing is required before final assembly and testing the RF circuit. With R1 still not installed, the drain and gate voltage will not be connected to Q1 so voltage may be applied to the feed through without endangering Q1.

Apply a DC input of +7 to +17 VDC to the feed through connector and ground lug. Measure +5VDC on the output side of VR1. Verify that the +5VDC travels through the drain circuit biasing to the Junction of where R1 is to be assembled. If it is not there, find the open circuit and repair. Now verify that the gate bias is functioning correctly. Measure the voltage on the Q1 side of C2. It should be less than -0.8VDC (Negative voltage). Adjust R5 to obtain -0.4VDC. Again if any of the voltages can not be obtained, trace the circuit for problems.





There should be -5 VDC on pin 5 of IC1. If it checks out, remove the DC voltage from the LNA and install R1.

**Final Testing:**

Install a 50 ohm load to both input and output connectors or your 50 Ohm gain measuring equipment. This can be a termination, an antenna, or a receiver. Apply the DC voltage to the feed through connector and verify that the drain lead has voltage. It should be between 2 and 5 volts DC. Now measure the drain current. This is either measured across R6 (150 ohm resistor with the use of Ohms law) or may be measured directly on the +DC supply line. The drain current should be between 15 and 20 mA. The drain current can now be adjusted by varying R5. As the gate voltage approaches 0VDC, the drain current will increase. If the gate voltage is adjusted more negative, the drain current will decrease. Adjust R5 for approximately 20-25 mA of drain current.

If the DC testing is correct, the LNA will be operating correctly and the RF adjustments should not be attempted unless you have a way of measuring Gain and/or Noise Figure. Just re-test the DC current drain to ensure proper operation. Even if you do have the equipment available, there will only be minimal adjustments, if any, to be made to improve the performance of the LNA. If it is assembled correctly and the bias is set correctly, the LNA will perform correctly rather well.

If you desire to "Trim" the circuit to optimize, the trace directly connected to the Gate of Q1 can be made narrower to improve the NF. The stub after R1 may be adjusted for improved gain. Also test with the Lid on.

The lid may be installed with sealant after testing is complete if desired.

**Component List**

All components are 1206 size chips unless indicated. The white band is positive on the Tantalum chip capacitors. All other capacitors are various sizes.

C1 0.1µF	C5 4.7 µF Tant	C9 2.7 pF ATC	R1 10	R5 1K pot
C2 2.7 pF ATC	C6 4.7 µF Tant	CR4 MMBD914	R2 51 0805	R6 150
C3 0.1µF	C7 0.1µF 1210	IC1 7660 SMD	R3 5.1K	VR1 78L05
C4 1.0 µF Tant	C8 2.7 pF ATC	Q1 CE3512K2	R4 51 0805	PC Board

**Hardware Parts List**

1 - Enclosure and Lid	12 - 4-40 x 1/4" screws
2 - RF connectors , SMA or "N"	5 - 3-48 x 3/16" Fillister head
1 - #8 ground lug	1 - 1N914 type diode
1 - #8-32 feed-thru connector	

## Component Placement

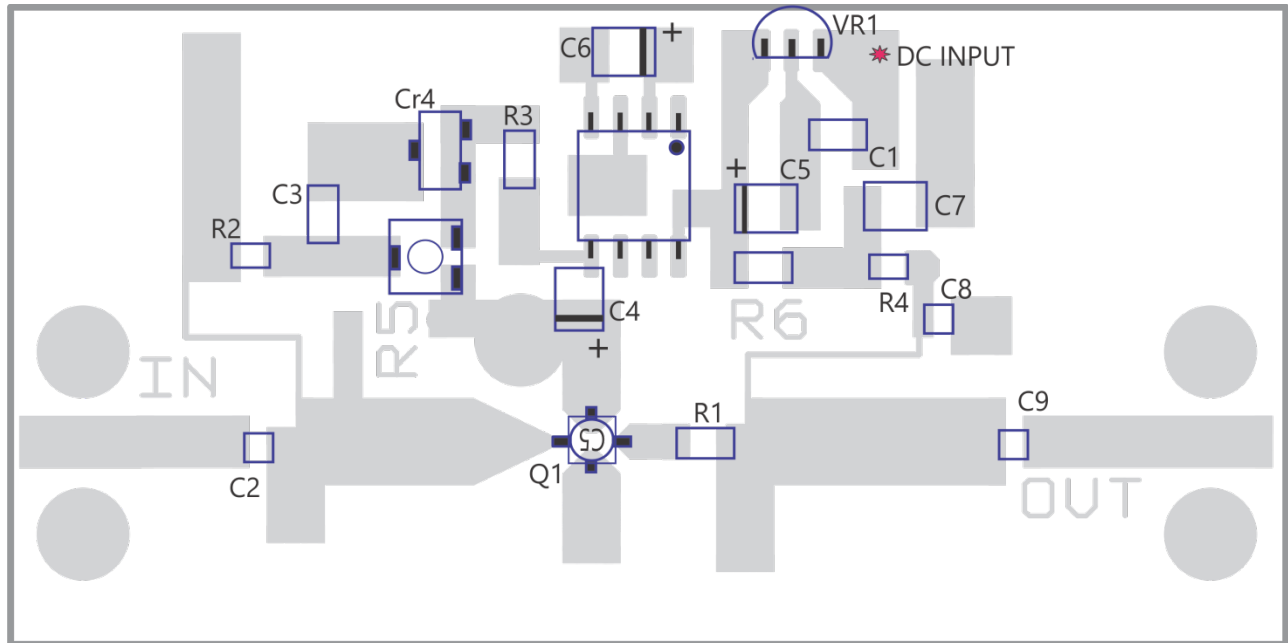

## L5ULNA SCHEMATIC

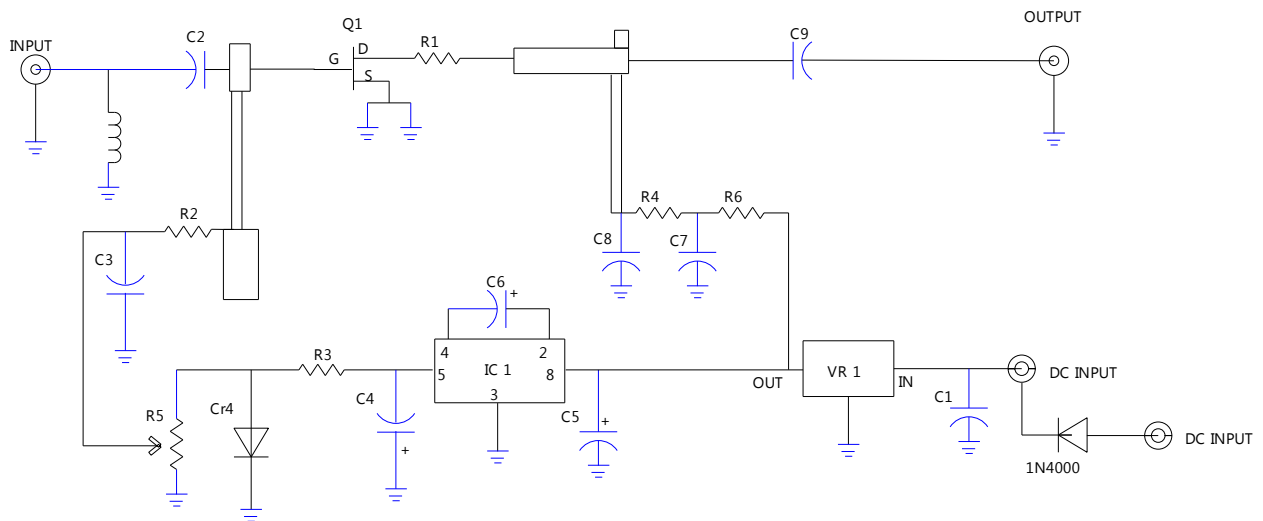

### PIN CONFIGURATION AND INTERNAL BLOCK DIAGRAM

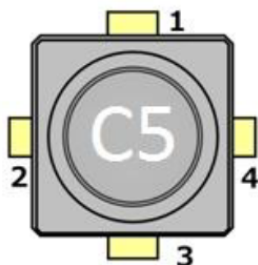

Pin No.	Pin Name
1	Source
2	Drain
3	Source
4	Gate