

CLIENT	STD PRODUCT
ISSUE	AMENDMENT
A	ASSEMBLY DETAILS ADDED 14/9/12 CS

3rd ANGLE PROJECTION

All rights are strictly reserved and copying or disclosure in part or full to a third party is strictly forbidden without the written consent of ALTRON COMMUNICATIONS EQUIPMENT LTD.

IF IN DOUBT ASK ALL ERRORS TO BE REPORTED

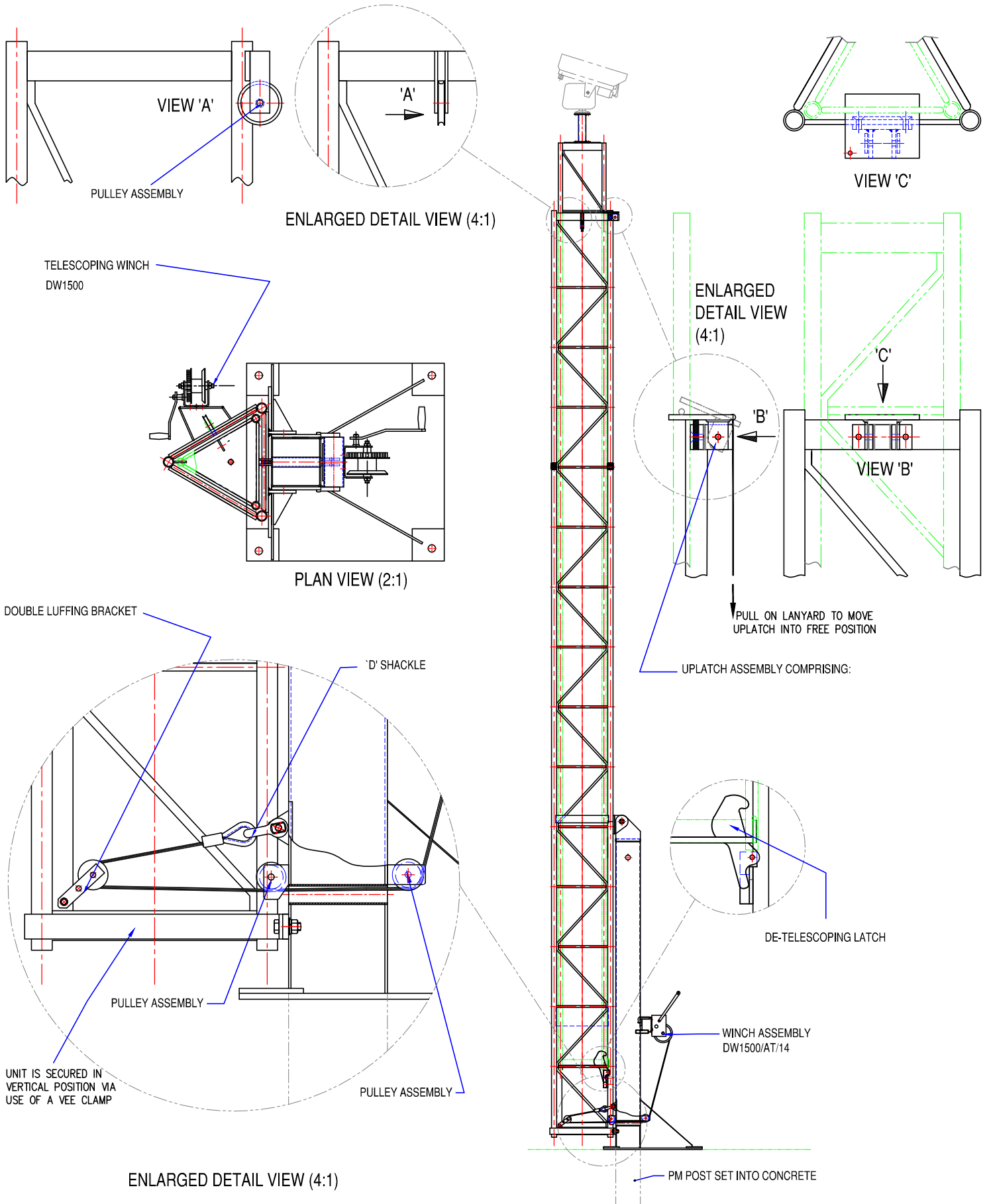

DIMENSIONS IN mm UNLESS OTHERWISE STATED © ALTRON COMMUNICATIONS EQUIPMENT LTD. ALL RIGHTS RESERVED DO NOT SCALE

TITLE			
ACT14 BP ASSEMBLY DIAGRAM SHEET 1			
DRAWN	GIJ	CAD RELEASE-1	
MATERIAL	EN10219	FINISH	GALVANIZE TO ISO 1461

ALTRON COMMUNICATIONS EQUIPMENT LTD
 TOWER HOUSE
 PARC HENDRE
 AMMANFORD SA18 3SJ
 TEL: (01269) 831431
 FAX: (01269) 845348
 e-mail: comms@altron.co



PRODUCT	DATE
ACT14 BP	MAY 14
DWG. No.	-

NOTE-TELESCOPING CABLE RUNS OVER THE FIRST HORIZONTAL BRACE AND THEN ANCHORS TO THE INNER CABLE ANCHOR PLATE WITH THE 'D' SHACKLE PROVIDED.
PLEASE NOTE THAT THIS WILL ALREADY BE INSTALLED UNLESS THE TOWER IS SPECIFICALLY SUPPLIED WITH THE TELESCOPIC SECTION SEPARATE.(NORMALLY SUPPLIED WITH SECTIONS ASSEMBLED).

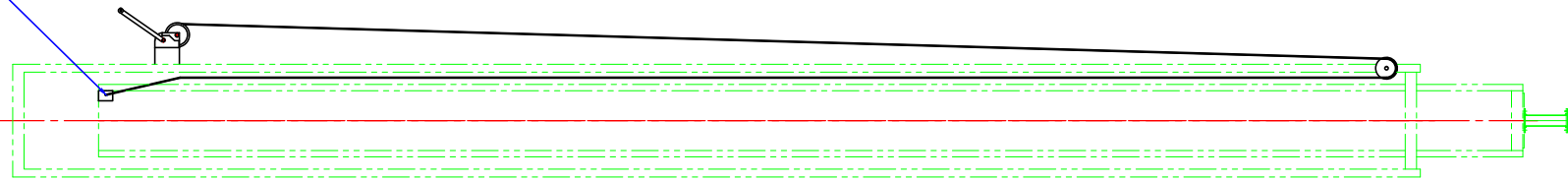

DIAGRAMATIC TELESCOPIC CABLE LAYOUT

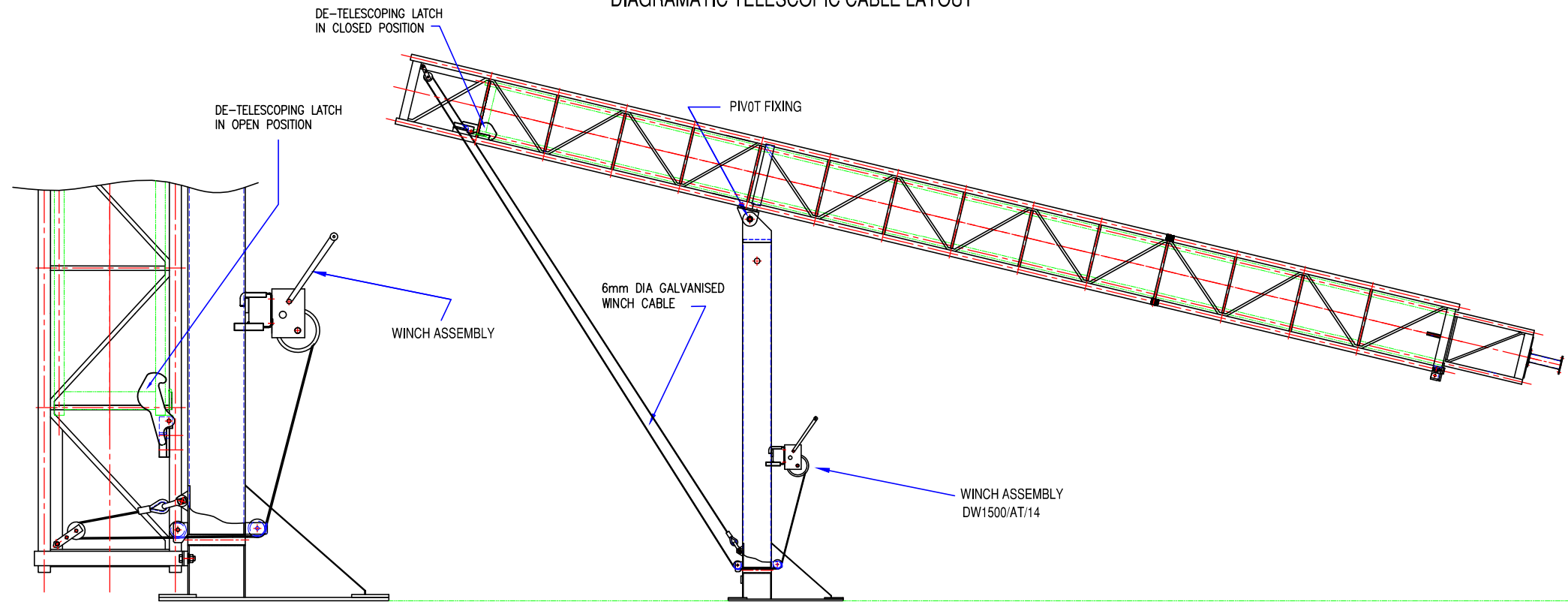

ALL RIGHTS RESERVED DO NOT SCALE

ISSUE	AMENDMENT
CLIENT	STD PRODUCT

DIMENSIONS IN mm UNLESS OTHERWISE STATED © ALTRON COMMUNICATIONS EQUIPMENT LTD.	
TITLE ACT14 BP ASSEMBLY DIAGRAM SHEET 2	
DRAWN GIJ	CAD RELEASE - 1
MATERIAL EN10219	FINISH GALVANIZE TO ISO 1461

ALTRON COMMUNICATIONS EQUIPMENT LTD
TOWER HOUSE
PARC HENDRE
AMMANFORD SA18 3SJ
TEL: (01269) 831431
FAX: (01269) 845348
e-mail: comms@altron.co



PRODUCT	DATE MAY 14
ACT14 BP	
DWG. No.	-



Altron Communications Equipment LTD

Issue date October 2014

ACT14 - Tilt-Down Tower – Operating Instructions

For both PM & BP mounting variations.

ALTRON towers are manufactured to a high standard and designed to be as simple and as safe as possible to operate. However, as with all mechanical equipment they require correct operation to ensure safety and performance.

Safety Precautions – Read These Before Operation

1. OBSERVE THE STATED LOADING VALUES, DO NOT OVERLOAD THE TOWER.
2. Ensure the area in line with the fall of the tower is kept clear of all personnel when raising and lowering. Do not stand behind or below tower when operating; stand to the side. If in a public access area, make the area safe by means of a barrier.
3. Maintain winch and winch cable in good condition. Consult winch operating & maintenance notes below.
4. Before each tilting operation check that the cables are correctly seated in their pulleys. Check for signs of fraying or wear on the cable and that the splicings are secure. Check that cable is wound tightly onto the winch drum and no trapped loops exist. If unsure, wind cable off of the drum and re-wind on to ensure it is evenly layered
5. Before operating the tower, ensure that the area around the base of the tower is clear and that there are no trip hazards.
6. To ensure safe operation, concentrate on all aspects of the operating procedure at all times and be aware of the safety of those around you.

To Operate – (read in conjunction with assembly diagram)

1. Fit double luffing bracket to the base of the tower section using bolt and wing nut.
2. Hook the demountable winch unit onto post.
3. Bolt pulley wheels in position on front and back of post if not already fitted.
4. Pull eye end of cable through the post, under pulleys and feed cable behind pulley on the double luffing bracket (pulley on double luffing bracket needs to be removed and then replaced with cable behind it – ensure that wing nut is tightened securely) and anchor with 'D' shackle on the anchor lug on the post/base post.

5. To lower tower telescoping section, using the winch permanently attached to the tower section, wind the handle clockwise (the clicking of the ratchet engaging will be heard) and raise the tower telescoping section a couple of inches. Pull the lanyard that is attached to the 'uplatch' so that this pulls back fully and dis-engages. If it does not dis-engage fully, raise the tower section a small amount more until the 'uplatch' does fully dis-engage.

6. Now whilst keeping tension on the 'uplatch' lanyard to ensure it stays dis-engaged, wind the winch handle anti-clockwise, so that the telescoping tower sections lowers. The winch will be winding against the friction brake pad and no ratchet sound will be heard.
 7. Lower the telescoping tower section until it comes to rest on the stop in the bottom of the outer tower section, stop winding the winch cable 'out'. Wind back 'in' if necessary to ensure that there is no slack in the cable, making sure that the tower section is not raised up off the stop.
-
8. Referring back to the demountable winch unit. Before tilting the tower ensure the cable is wound tightly on to the winch drum, layered evenly and the cable eye end is securely anchored. Ensure slack is taken up so that the winch cable is pulling the tower onto the post.
 9. Remove the retaining 'V' clamp that holds the tower to the post/base post. The tower is now held entirely on the winch. **Do not remove the retaining 'V' clamp unless the winch and cable are correctly fitted to the tower.**
 10. Wind the winch handle 'out' (winding handle anti-clockwise) half a turn (180 degrees) to allow enough slack for the tower to start lowering. It will be necessary to push the tower away from the post and continue this operation until the tower section has tilted far enough to carry on unaided.

Continue to wind winch handle 'out' to lower tower. Use a steady even action on the winch handle so that the tower does not bounce. A jerky operation of the winch handle will cause the tower to bounce which is not desirable.

11. Ensure the winch cable has tension on it, as a result of the tower weight, at all times during the lowering operation. A runaway snatch load, caused by slack in the winch cable, may result in damage to both the winch system and the equipment fitted to the tower. When lowering, the friction brake will engage within the winch.
12. Continue until the tower is lowered to its horizontal service position. Wind the winch handle clockwise so that the ratchet engages and two clicks are heard and allow tower to rest in the horizontal position. The de-telescoping latch will engage under its own weight once the tower reached the horizontal position.

Note, when winching 'out' a minimum of 3 wraps of cable **must** be left on the winch drum.

To raise Tower

13. Turn winch handle clockwise to winch 'in' and raise the tower. A clicking sound will be heard from the winch ratchet engaging. When tower is fully raised to vertical position, keep tension on the winch cable so that it pulls the tower onto the base post and then fit retaining 'V' clamp.

Do not attempt to dis-connect the winch cable from the tower section until retaining 'V' clamp is secure.

14. To raise the telescoping section, on the winch permanently attached to the tower section, wind the handle clockwise, a clicking sound will be heard from the ratchet engaging. The 'uplatch' will click over each horizontal rod in the telescoping tower section, this is okay and there is no need to hold the 'uplatch' open with the lanyard. The de-telescoping latch will open under its own weight when the tower is in the vertical position.

15. Raise the telescoping tower section until the red marker on the inner section lines up with the red marker on the outer section. This indicates the towers' maximum raised position. **DO NOT RAISE TOWER PAST THIS POINT.** To support tower in the raised position, lower the inner section until it sits on the uplatch plate.

NOTE: DO NOT allow slack on the telescoping winch cable once the uplatch is engaged.

-
16. Referring back to the demountable winch unit, remove eye end of cable from cable anchor lug on the post/base post. Unbolt the double luffing bracket.
 17. Pull the eye end of the winch cable through the pulley brackets on the post, winding the cable onto winch drum. Keep tension on the cable by hand ensuring that it is layered evenly and once cable is fully wound on to winch drum, secure in place using the D shackle so that the winch cable does not unravel.
 18. Remove Winch unit.
 19. Once the winch unit has been removed, keep the cable wound tightly and layered evenly on the winch drum. If the cable becomes loose/ unravelled, then it will be necessary to unwind the cable off the winch and re-layer evenly and tightly before operating the next tower.
 20. The winch unit should be stored with care. Any alterations to the winch unit, separating it or modifying in any way will invalidate the warranty.

We recommend that a risk assessment is produced covering the operation of the tower. For a generic template, please contact our Sales office.

Winch - general operation notes

1. Never operate the winch by any other means than with the winch handle. **THE WINCH MUST NOT BE OPERATED WITH A POWER TOOL**
2. Ensure that ratchet engages on each operation (clicking noise will be heard when winding cable on to drum)
3. Never allow oil or grease to come into contact with the friction brake discs.
4. Ensure cable is wound tightly onto drum before operation.
5. Ensure winch is properly maintained - refer to guidance below.
6. Ensure operation as per Altron operating procedure
7. Ensure a minimum of 3 turns of cable on the winch drum before winch takes load.
8. IF IN DOUBT ASK (Call Altron technical on +44 (0) 1269 831431 or e-mail cctvsales@altron.co.uk)

Winch inspection and maintenance

Carry out the following checks and maintenance at least annually.

1. **WARNING!** Do not lubricate friction (braking) discs. This can cause slipping or failure.
2. Apply a drop or two of #30 weight engine oil to each bushing I.D. and to the ratchet pawl pivot points. Maintain a thin layer of chassis grease on the gear teeth.

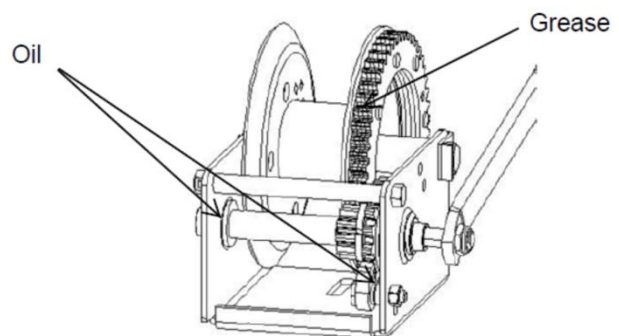

3. Check for wear on the gear teeth on the winch drum or gear on the primary shaft. If excessive replace winch. Check load being applied to winch as overloading will cause excessive wear.
4. Clean debris off winch and ensure grit and debris is cleared from gears
5. Check for any damage that has taken place i.e. denting or distortion on the winch drum or winch casing – if present then replace winch.
6. Inspect the winch cable for fraying, kinks or flattening along its full length. If the winch cable is frayed, flattened or kinked; replace. Investigate why fraying or flattening has occurred.
7. Check the friction (braking) discs for wear. If less than 1.5 mm thick, cracked or broken, replace immediately.
8. During winch use, check for proper ratchet pawl operation as follows. When cranking cable in, a ratchet clicking sound should be heard. When cranking cable out, there is no clicking and the ratchet pawl must be fully engaged into the gear teeth. If this does not take place, then stop using the winch and contact Altron.