

COMMANDER 400 OPERATION MANUAL

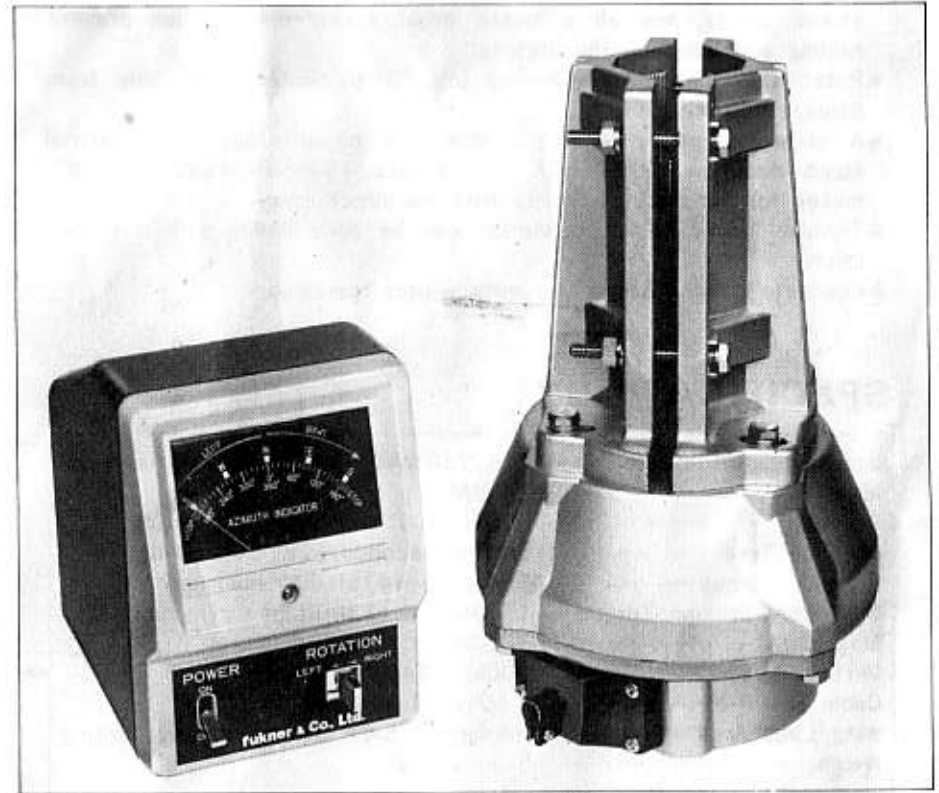

MODEL FU-400 of the COMMANDER ROTOR SERIES

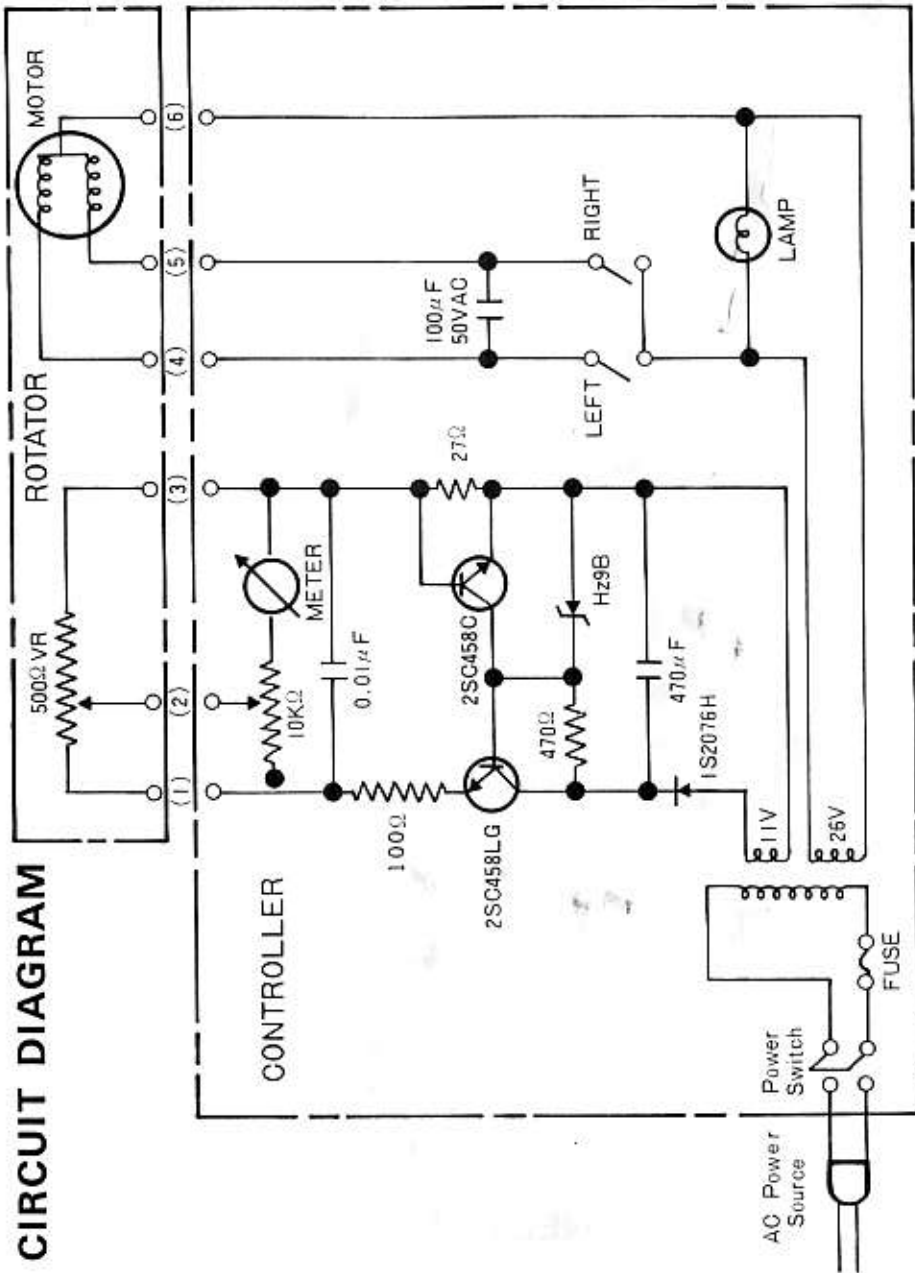

fukner & Co., Ltd

FEATURES

- *Transformer reduces input voltage to a safe 24 VAC so that an economical 6-core cable can be used.
- *Adjustable mast clamp with grooved inner lining that firmly grips allows for perfect centering of mast so that all the power is concentrated in rotating.
- *Tempered mold and die cast gears reduce noise and increase durability.
- *The melamin-coated, die cast aluminum housing, reinforced at all stress points, and all stainless steel screw construction prevent rusting and lengthen the lifetime.
- *Rotation is mechanically limited to 360° to protect the cable from damage and wear.
- *A stabilized power source built-in the circuits and an industrial sized direction finder with two scales (S-W-N-E-S and 0° to 360°) makes for accurate and easy antenna directioning.
- *Terminal board cable connection can be done easily with a screw driver.
- *Complete water-proofing prevents winter freeze-up.

SPECIFICATIONS

Input Voltage	115/220 VAC, 50/60Hz, 40 VA maximum
Motor	24 VAC
Rotation	360°+5°/0° with mechanical stop
Rotation Time	50Hz-60seconds/60Hz-50seconds
Rotation Torque	550kg-cm (475ft-lbs) minimum
Stationary Braking Torque	1500kg-cm (1300ft-lbs) minimum
Mast Size	38-50mm (1½-2") diameter
Verticle Load	200kg (440lbs)
Cable	6-core/0.5mm ² (#22)
Wing Load Area	0.5-0.8m ² (5.4-8.6ft ²) with stay bearing
Weight	5kg (11lbs)

PACKING LIST

The following parts are included with the Commander 400.

PART	QUANTITY
Rotator	1
2-Piece Mast Clamp	1 set
Hexagonal Bolt $W\frac{1}{4} \times 2\frac{1}{4}$ " ($W\frac{1}{4} \times 55$ mm)	4
Hexagonal Bolt $W\frac{1}{4} \times \frac{1}{2}$ " ($W\frac{1}{4} \times 15$ mm)	4
Spring Washer $W\frac{1}{4}$ diameter	12
Washer $W\frac{1}{4}$	8
Nut $W\frac{1}{4}$	4
Hexagonal Bolt $W\frac{1}{4} \times 1$ " ($W\frac{1}{4} \times 25$ mm)	4
Controller	1
Operation Manual	1

- * Lower Clamp Set is sold with Commander 400 in some areas.
- For parts included in the set, please refer to page 11, "Accessories" for Rotator.

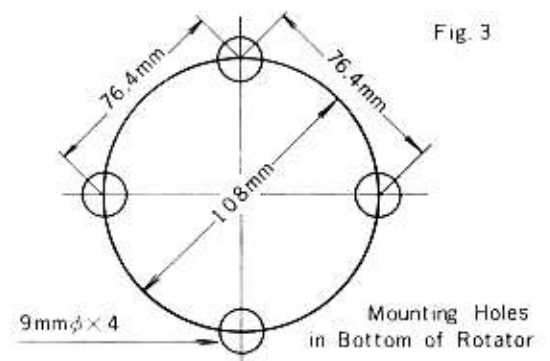
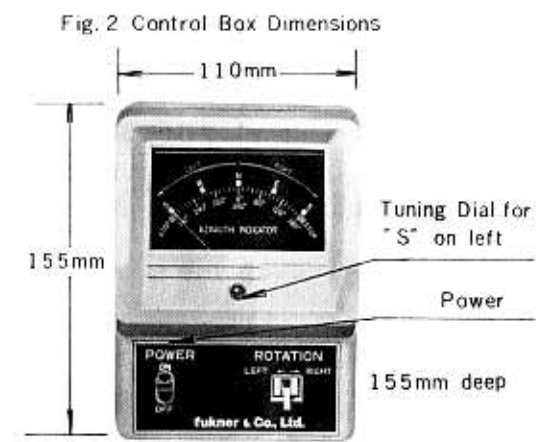
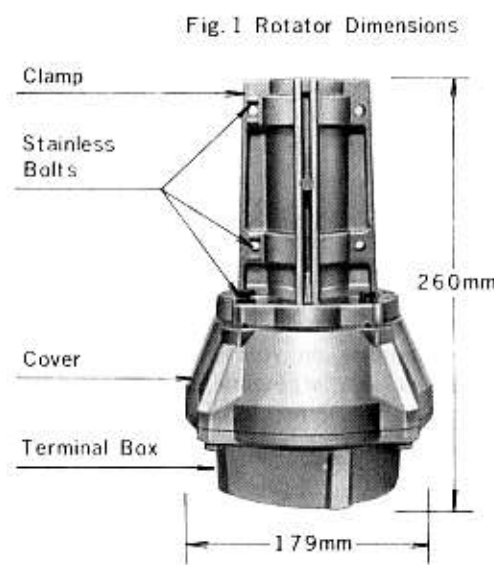

COMMENTS PRIOR TO INSTALLATION

The Commander 400 is designed for medium sized Ham antennas. Do not try to mount large scale beam antennas. The maximum weight varies depending on how the rotator is mounted, the topology of the surrounding land, strength of the wind and the physical size of the antenna. The mounting examples shown in the chart below have been tested and found to be workable. Note that the maximum load changes considerably when a stay bearing is used.

		WIND LOAD AREA m ² (ft ²)	TOAL WIND LOAD AREA m ² (ft ²)
with stay bearing	114MHz8Ele + 21MHz3Ele	0.18(1.9)	0.58(6.15)
	144MHz9Ele + 430MHz8Ele	0.40(4.25)	
	21MHz3Ele + 28MHz3Ele	0.20(2.25)	0.60(6.5)
	50MHz5Ele + 21MHz3Ele	0.40(4.25)	
	14MHz3Ele + 7MHz2Ele	0.35(3.75)	0.71(7.6)
		0.40(4.25)	
without stay bearing	144MHz12Ele	0.31(3.3)	0.75(8.0)
	50MHz6Ele	0.60(6.5)	0.90(9.7)
	28MHz5Ele	0.20(2.25)	0.20(2.25)
	21MHz3Ele	0.40(4.25)	0.40(4.25)

Note: Total Wind Load Area for mounts with stay bearing should be around or below 0.8m²(8.6ft²), and for mounts without stay bearing it should be around or below 0.5m²(5.4ft²)

Other items necessary for installation are

6-core cable over 0.5mm² (22).....use only the necessary length
tower.....roof, free-standing, or mast depending on your preference
stay bearing.....recommended for antennas with large wind load areas
straight steel pipe.....38.50mm(1 1/2") diameter, maximum length of
2 meters with stay bearing but should be as short as possible
antenna assembly

TESTING THE CONTROL BOX AND ROTATOR

Remove the covers from the terminal boards on the control box and rotator and pass the 6-core cable through hole in same. Connect the 6 cable wires to the terminal boards on the control box and rotator, being sure to solder the ends of the wire carefully to avoid shorts later on. When the connections have been made, replace the covers on both terminal boards. Temporarily fix the mast clamps to the upper part of the rotator with the 1" screws supplied.

The needle on the direction meter should point to the S/180° on the left when the power switch is off (refer to figure 4). If the needle does not point directly to the S/180°, adjust with the tuning dial on the front of the control box below the meter.

When the power switch is turned on, the meter lights up. Push the direction switch to the LEFT, and the meter needle and rotator will move in a counter-clockwise direction. When the needle comes to the S/180° position, the rotator will stop. Release the switch. Then push the switch to the RIGHT until the rotator stops. If the needle does not point directly to the S/180° on the right, adjust with the turning dial on the back of the control box shown in figure 5.

Before mounting, set the rotator so that the needle points to N/0°.

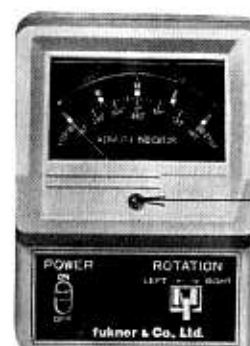

Fig.4

Tuning Dial
for 'S' on left

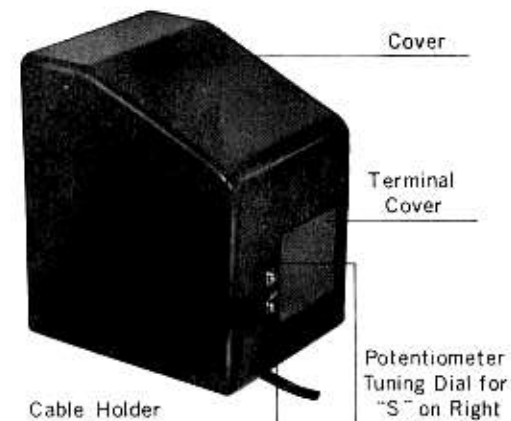

Fig.5

Potentiometer
Tuning Dial for
'S' on Right

MOUNTING

The installation method depends on the chosen mount. Below we have given the example of a roof tower mount with stay bearing.

1. Fix the rotator to the roof tower with the four $\frac{1}{4}$ " screws supplied. Be sure that the rotator is in an upright position and not up-side down. The screws should be tight enough to hold the rotator, but should not be over-tightened. Then mount the stay bearing to the top of the roof tower in the same way. Be sure that the platform the rotator is mounted to is perfectly parallel to the surface the stay bearing is mounted to. If they are not parallel, pressure will be applied unevenly and may cause damage to the rotator.

2. Insert the mast through the stay bearing from the top and bring it down between the clamps to a point a little above, but not touching, the clamp base as shown in figure 6. Secure the 4 upper screws in the middle of the stay bearing. Be sure the mast is centered using the center line on the cover as a guide. With the mast clamps slightly loosened, carefully turn the mast so that the antenna faces due north and then tighten the clamps firmly. Then tighten the 4 lower screws on the stay bearing and lock nut securely. When the antenna, stay bearing and rotator are mounted, the rotator is protected from damage caused by even strong winds. When the antenna has 2 or more tiers, be sure to make the distance between the upper most antenna and stay bearing as short as possible and no greater than 1.5m (5ft).

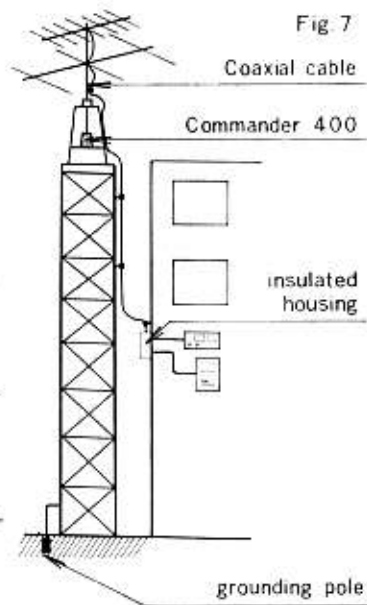
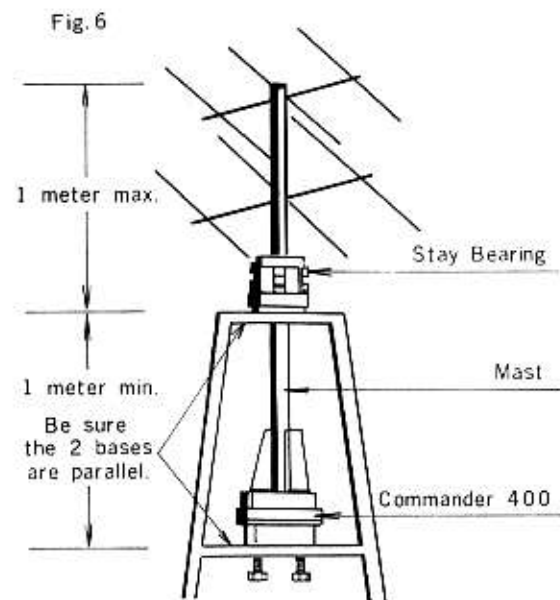

3. Attach the coaxial cable to the mast and roof tower being sure there is enough slack so that the rotator can turn a full 360° without straining the cable as shown in figure 7. Fix the cable to a leg of the roof tower with tape.

Be sure the tower is fixed firmly to stand up against the strongest winds likely in your region. Also be sure that in case it does fall, it will not hit electric wires.

4. Ground the tower in case it is struck by lightning. Fix the earthing wire (2.6mm²-#9 minimum) at least 1.5m (20') above the roof and connect to the grounding pole at least 1.5m (5') long buried in the ground. Be sure the grounding wire and pole are placed as far as possible from electric wiring and water lines. To ground the coaxial cable attach an arrester to the cable at the point it enters the house.

Installation of other mounts is basically the same. Make sure the tower is firmly set and well grounded. It is advisable to use a stay bearing to reduce pressure on the rotator. But when a stay bearing is not used, use as short a mast as possible so that the antenna is close to the rotator. Also put the center of gravity of the antenna assembly as close to the mast as possible.

CAUTION

1. When the rotator is not in use, be sure the power switch is off.
2. When the needle on the meter is pointing to S/180° at either extreme, the rotator is mechanically shut off. Do not try to force the rotator beyond this point, as it will only cause damage to the rotator.
3. Limit continuous operation of the rotator to 5 minutes. If the rotator is operated continuously for over 10 minutes, rest the motor 10 minutes before resuming operation.
4. If the distance between the stay bearing and antenna is longer than the maximum mentioned above, it is advisable to use an additional stay bearing. The central axis of the rotator and second stay bearing often do not coincide. In such cases, the guide wires supporting the roof tower will have to be adjusted. When making the adjustments, be sure that the tension on each wire is the same so that the mast will not be bent and test to be sure the mast will rotate without being subject to undue pressure.

MAINTANENCE

When meachnical problems occur, please follow the below mentioned suggestions. If the problem cannot be solved by these, consult with the shop from which you purchased the Commander 400.

NON ROTATION

Non rotation or sporadic rotation is often caused by broken or shorted wires near or at the terminal strips. Time can be saved later by carefully soldering and connecting the wires when the rotator is being mounted. Another cause of non rotation is a fuse break. Open the control box case, replace the safety fuse and test the rotator once more.

ANTENNA SLIPPING

Some mechanical play which may be mistaken for slippage is built into the rotor. One degree of movement at the rotator can cause a movement of several centimeters at the end of the antenna boom. High winds can cause similar antenna movement. To avoid actual slipping, be sure that the clamp screws are well tightened to hold the mast securely.

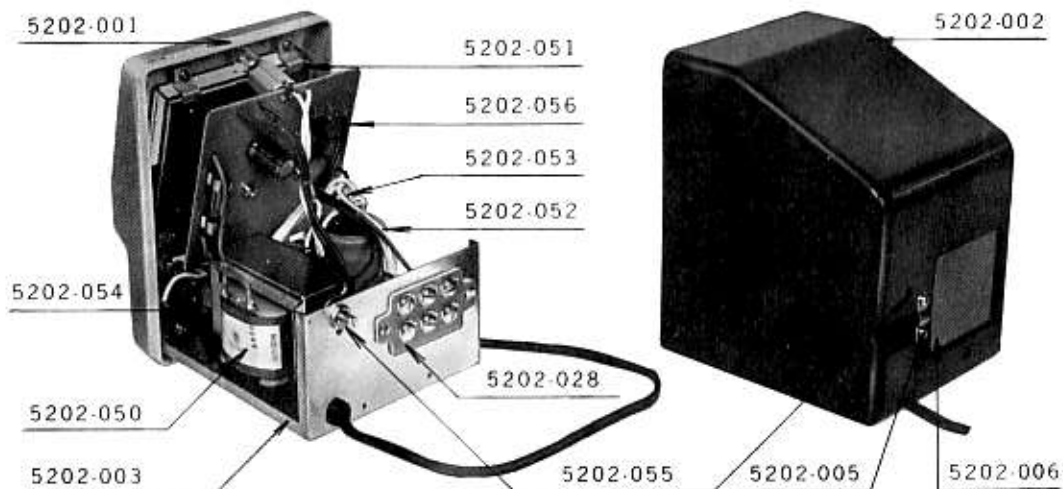

PARTS LIST FOR CONTROLLER

PART NO.	NAME	QUANTITY
5202-001	Panel, ABS.....	1
5202-002	Cover, ABS.....	1
5202-003	Chasis.....	1
5202-050	Transformer, 40 VA maximum.....	1
5202-051	Meter Assembly.....	1
	meter, DC 1 miliamp	
	hardware	
5202-052	Condenser, 100 μ 50 VAC.....	1
5202-028	Terminal Board.....	1
5202-053	Power Switch.....	1
5202-054	Left-Right Switch Assembly.....	1
5202-055	Potentiometer, 10 kilo-ohm.....	1
5202-005	Cable Holder.....	1
5202-056	Circuit Board.....	1
	Zenner diode, H29B	
	transister, 2SC458C	
	transister, 2SC458LG	
	diode, 1S2076H	
	power condenser, 470 μ F 16 VDC	
	ceramic condenser, 0.01 μ F 50 VDC	
	resister, 470 ohms $\frac{1}{4}$ watt	
	resister, 100 ohms $\frac{1}{4}$ watt	
	resister, 27 ohms $\frac{1}{4}$ watt	
	swan socket	
	swan bulb, 28 VAC	
	fuse, 1A	
	fuse hardware	
5202-006	Terminal Cover, transparent vinyl.....	1

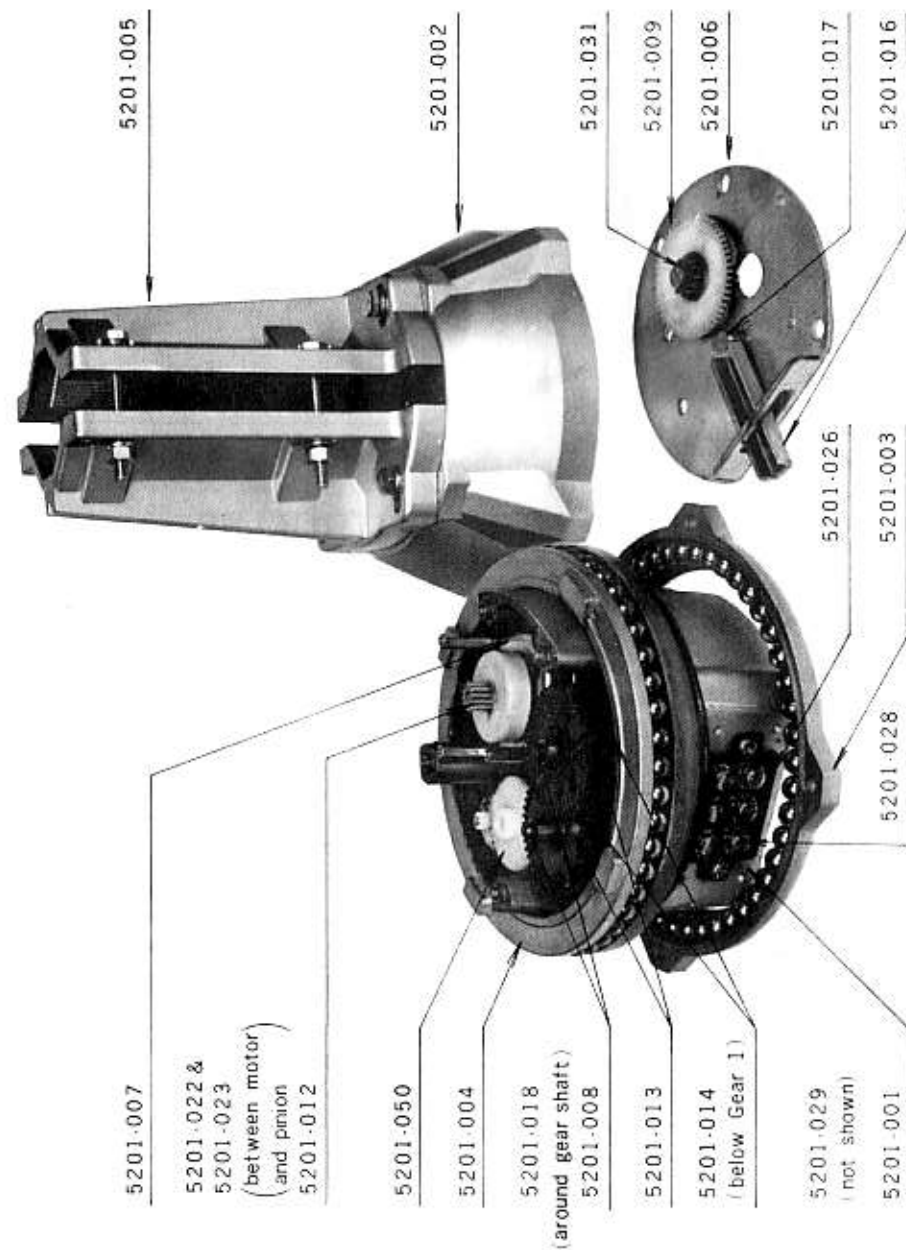

PARTS LIST FOR ROTATOR

PART NO.	NAME	QUANTITY
5201-001	Lower Case, ADC 12 aluminum	1
5201-002	Cover, ADC 12 aluminum	1
5201-003	Bearing Ring, ADC 12 aluminum	1
5201-004	Internal Gear, ZDC 1 aluminum	1
5201-005	Mast Clamp (2-piece), ADC 12 aluminum	1 set
5201-006	Plate	1
5201-007	Motor	1
5201-031	Mold Gear Shaft	1
5201-008	Gear Shaft	2
5201-009	Mold Gear Assembly, duracon	1
5201-012	Motor Pinion, duracon	1
5201-013	Gear with pinion (Gear #1)	4
5201-014	Gear without pinion (Gear #2)	2
5201-016	Stopper	1
5201-017	Stopper Pin	1
5201-018	Collar #1, 8.8mm (11/32")	1
	Collar #2, 5.5mm (7/32")	
5201-050	Potentiometer Assembly	1
	Potentiometer, 500 ohms	
	Mount	
	Gear #1, duracon	
	Gear #2, duracon	
5201-022	Break Seat	2
5201-023	Break Mount, polycarbonate	1
5201-026	Packing in terminal board	1
5201-028	Terminal Board (6 pins)	1
5201-029	Terminal Cover	1
	Ball Bearings, 3/8"	94
	O-Ring, G-125	1

ACCESSORIES

LOWER CLAMP ASSEMBLY

5201-051	Lower Mast Clamp	1 set
	Clamp (2-piece), ADC 12 aluminum	1 set
	Hexagonal Bolt $W\frac{1}{4} \times 1"$ ($W\frac{1}{4} \times 25mm$)	4
	Hexagonal Bolt $W\frac{1}{4} \times 2\frac{1}{4}"$ ($W\frac{1}{4} \times 55mm$)	4
	Spring Washer $W\frac{1}{4}$	8
	Flat Washer $W\frac{1}{4}$	8
	Nut $W\frac{1}{4}$	4

METAL CONNECTOR

used in place of the above mentioned 5201-028 terminal board on specially ordered executions