



M2 Antenna Systems, Inc. Model No: OR2800PXAZ

Preparation

Basic Operation

Advanced Operation

Trouble Shooting



CAUTION PLEASE READ!

Warning!

THIS OR2800PXAZ POSITIONER
WILL **NOT** WORK WITH
RC2800P CONTROL BOXES THAT
SUPPLY AC POWER.
SEVERE DAMAGE WILL RESULT!

BUILDS THE BEST ROTATOR SYSTEM! THE NEW GREATLY IMPROVED OR2800PX-AZ

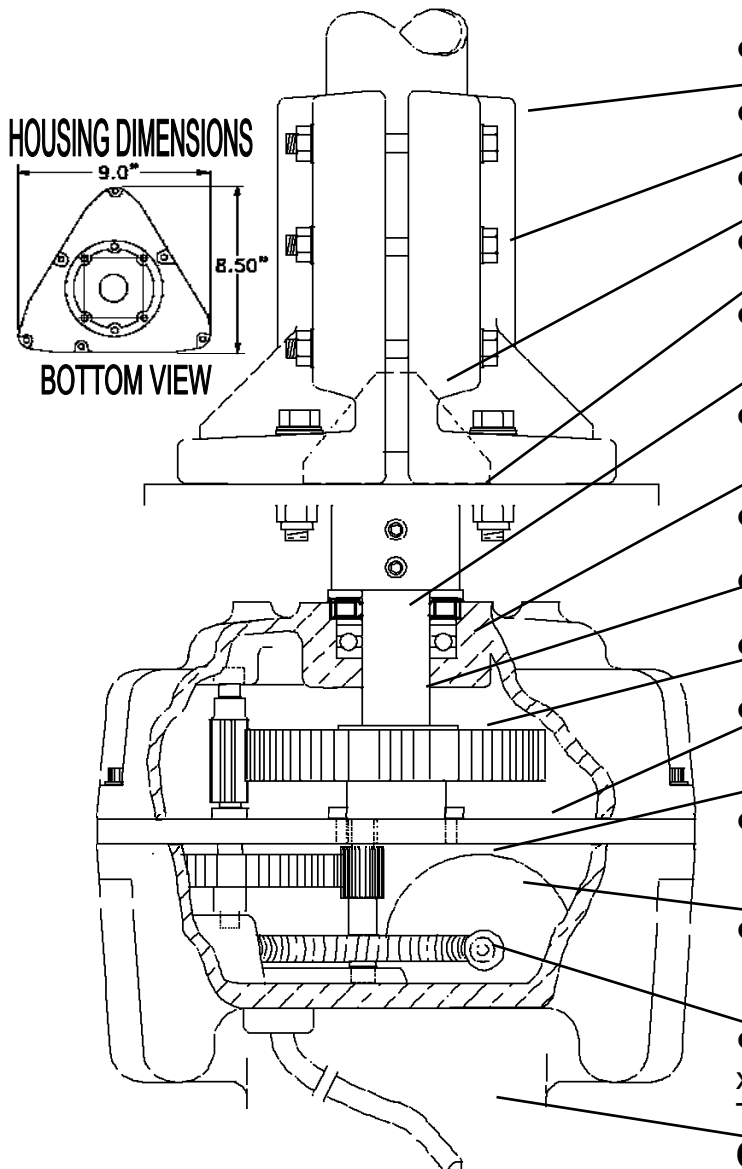

- Ductile iron, massive, toothed mast clamps
- Grade 5, 3/8-24 steel hardware
- Self-centering mast guide
- Drive plate accepts masts up to 3-1/8" O.D.
- **NEW! 6-SPLINED OUTPUT SHAFT AND HUB**
- Large 2000 LB thrust bearing handles high mast loads with low friction
- Lengthened and hardened output shaft
- Heat-treated, machined steel gear train
- Prop-pitch style torque plate
- Magnetically actuated pulse circuit for accurate heading and target accuracy
- **NEW DC MOTOR WITH HIGH TORQUE 5:1 SPEED RANGE (see specs)**
- Precision wormdrive - cannot be reversed by mast torque.
- Standard Ham M etc. 3" x 3" bolt pattern +2 xtra holes, - fits inside towers like Rohn 25 & up, Triex LM-354 & up U.S.Towers TX438 & up.

OR2800PXAZ SPECIFICATIONS

Wind Area Capacity	35 sq.ft.
Starting Torque	4200 in. lbs.
Rotating Torque	3200 in. lbs.
Braking Torque	17000 in. lbs.
Vertical Load Capacity	1800 lbs.
Height of just the positioner	9.75"
Total height to top of clamps	15.75"
Mast Size (O.D.)	1.75" up to 3-1/8"
Rotation Speeds / 360°	55 TO 270 sec.
Rotation Range	0-360° ±14°
Readout resolution	0.1°
Travel Accuracy	± .5°
Input Voltage	110 / 220 VAC
Motor voltage	28-42 VDC
Cable req. - min.	2-#18, 2-#22
Weight (rotator unit)	42 lbs.

CONTROL UNITS

RC2800PXAZ Programmable Control Unit WITH RS232 INTERFACE

RC2800PRK DUAL for AZ-AZ or AZ-EL control of OR2800 and MT3000AEL or prop pitch.

All control units feature RS232 port for computer control. Manual operation standard with 10 programmable presets plus 1 flexible preset, Programmable Speed and Ramped start and stop, 0.5° target accuracy. (Works with the "DX4WIN" logging program plus Nova and Skymoon for satellite and moon tracking). No other hardware required. Optional prop pitch rotator control.

OR2800PXAZ POSITIONER MANUAL

TOWER-MOUNTED INSTALLATIONS

NOTE: THROUGHOUT THIS MANUAL WE USE THE WORD “POSITIONER” IN PLACE OF THE MORE COMMON TERM “ROTATOR” THIS SYSTEM IS USED ALL OVER THE WORLD FOR BOTH AMATEUR AND COMMERCIAL/GOVERNMENT APPLICATIONS. “POSITIONER” IS A MORE GENERIC AND UNIVERSALLY UNDERSTOOD TERM THAN “ROTATOR”. THE QUALITY, HIGH READOUT AND POINTING ACCURACY PUTS THE OR2800DC IN THE “POSITIONER” CATEGORY.

WARNING:

- MAKE SURE THAT THE POSITIONER UNIT, CABLE, AND **YOU** DO NOT COME IN CONTACT WITH HIGH VOLTAGE WIRES. POWER LINE VOLTAGES CAN KILL OR CAUSE SERIOUS INJURY.
- A GROUND SYSTEM FOR LIGHTNING PROTECTION IS RECOMMENDED.
- USE PROPER SAFETY BELTS AND TOOLS DURING INSTALLATION.

PRE-INSTALLATION TIPS AND CONSIDERATIONS:

1. For best results, test and calibrate the OR2800PXAZ System (positioner, cable, and control unit) on the ground BEFORE installing the positioner on a tower. This will familiarize you with the components and controls, their proper function, and allow testing of the terminal wiring and connector. Upon completion, the positioner can be run to a known compass or landmark heading. After the positioner is installed the antenna is simply aligned to that heading and installation is complete. Also see the Control Unit Instructions.

NOTE: *Mast clamp bolts are supplied 1-3/4 to 2-1/2” masts. Contact M² if you need longer bolts.*

2. Grade 5 and better steel hardware (zinc-plated) is used in place of stainless steel where high-torque and/or shear strength are required.

3. The base of the positioner is designed to mount to a flat plate using a 3” square hole pattern drilled to clear 3/8 bolts. Most standard mounting plates supplied by tower manufacturers are predrilled to the standard 3” pattern, but some may need to be drilled out to 3/8”. Six 3/8-24 x 3/4” bolts are provided for plates 1/4” or less thick. Longer bolts must be used if the mounting plate is thicker. **At least 3/8” to 1/2” must extend above the mounting plate to thread into positioner.** Recently we added two more *OPTIONAL* mounting bolt holes to the bottom casting. Refer to “HOUSING DIMENSIONS AND HOLE PATTERN” page.

4. Positioner installation may vary depending on tower type. The Rohn 25G tower is the smallest that will accept the OR2800DC Positioner and only in the TOP section that tapers into a mast guide-tube. The positioner cannot *EASILY* be installed in any other part of the tower. Other tower types may require the positioner to be inserted through the diagonal bracing. Where installation clearances are minimal it may be helpful to remove the DRIVE PLATE:

To remove DRIVE PLATE Remove the 1/4-20 bolt in the middle of the drive plate. Then lift the plate up and off of the splined driveshaft. Gentle prying with two large flatblade screwdrivers will usually get a stuck plate moving. In extreme cases replace the center bolt to about 1/8” from tight and use a wheel or gear puller to remove the plate. Pressing on the centerbolt while holding the plate will force the hub and plate off the splined shaft.

5. POSITIONER DUTY CYCLE

The OR2800DC Positioner motor and RC2800DC Controller is designed for maximum torque in Intermittent duty and is thermally protected. Continuous operation for more than 30 minutes at a time may cause overheating and temporary stoppage. After a few minutes to cool, the motor will again be ready for normal operation.

OR2800PXAZ ASSEMBLY MANUAL

INSTALLATION :

To minimize trips up and down the tower, review the installation instructions and carefully preplan the process of integrating mast, antenna(s), and positioner. Installation varies depending upon components already in place, new components to be installed, etc. Always use a safety belt and use your best judgment when working on a tower.

1. If installation permits, while the positioner is on the ground, run it to a known true heading or landmark heading that you will use to orient the antenna(s).
2. Install the positioner in the tower and secure to the base-plate with four (4) 3/8-24 x 3/4" bolts and flatwashers, lockwashers are not included. Use nylocks now. (For plates over 1/4" thick-see Pre-installation Note #2). No particular orientation is necessary at this point of the installation. Install for convenient hardware and cable connections. Install control cable and route up to the top of the section if it is a crankup tower or down the leg of a fixed tower. Secure every 6' or so with nylon ties or electrical tape.
3. Reinstall the drive plate on the drive shaft, if removed. Reinstall the short 1/4-20 bolt and 1/2" spacer on to the center of the drive plate . Then set the triangular-shaped MAST-CENTERING GUIDE over the bolt and spacer in the center of the drive plate.
4. Mount the CABLE JUNCTION BOX at a convenient location on the tower near the rotator. Alternately SLICE YOUR CABLE to the OR2800 cable and place the junction box at the base of the tower. This aids in trouble shooting and running the rotator from the base of the tower during installation of maintenance of antennas. Apply Scotchguard or equivalent water seal/repellent as required.

If you haven't already run positioner to a selected heading, do it now.

SYSTEM CALIBRATION. It is assumed that the OR2800 has already been calibrated to the RC2800 control box. IF NOT, RETURN TO THE RC2800PXAZ MANUAL AND DO THE "QUICK CAL" PROCEDURE in program mode "P0". This procedure runs the rotator AUTOMATICALLY to the COUNTER CLOCKWISE LIMIT SWITCH IN THE ROTATOR and a heading of "L346". This heading is 14 degrees COUNTER CLOCKWISE from 0.00 degrees (TRUE NORTH) If you reference alignment heading is TRUE NORTH, run the rotator CLOCKWISE ("CW or UP" BUTTON) to a heading of 0.00 on the RC2800PXAZ. If mast and / or antenna(s) are not already in place they may be installed now and TIGHTENED HEADING AT TRUE NORTH in conjunction with step 5, 6, 7 AND 86.

5. Attach the two (2) MAST-CLAMPS to the drive plate with four (4) 3/8-24 x 2" bolts, flatwashers, and locknuts. DO NOT TIGHTEN YET. Now allow the mast to come down onto the center-guide and slide the mast-clamps up against the mast. Install the 3/8-24 x 4" bolts into the clamps, using a flatwasher under each head and another flatwasher and a locknut at the threaded end.
6. Hand rotate mast and antenna (s) to selected heading already in positioner. Tighten all mast clamp bolts. FOLLOW THE BOLT TIGHTENING SEQUENCE OUTLINED BELOW. IT IS CRITICAL FOR A SECURE MAST!
 - A. Tighten the six 3/8-24 x 4" bolts just enough to bring the entire length of the clamps into contact with the mast.
 - B. Tighten the 3/8-24 x 2" bolts so that the clamps are flat against drive plate and jaws are parallel.
 - C. Completely tighten the six 4" bolts.
 - D. Completely tighten the four (4) 2" bolts.

OR2800PXAZ ASSEMBLY MANUAL

E. IMPORTANT NOTE:

The mast clamps provided with the positioner, when properly tightened, will not allow the mast to slip under normal weather variations. However, during extreme wind conditions a large antenna or array can generate extreme torque forces on the mast. In this instance, a small amount of mast slip is possible and even desirable. Slip may actually help prevent serious damage to the antenna, tower, and / or positioner components. For this reason, **DO NOT "PIN" THE MAST TO THE POSITIONER. PINNING THE MAST WILL VOID THE OR2800DC WARRANTY.**

GENERAL INFORMATION AND TROUBLE SHOOTING

RESISTANCE TEST OF CABLE AND ROTATOR

This test is done with the wires remove from the RC-2800PXAZ control unit. Turn off unit before removing wires.

FROM

One motor lead to the other:.....2.4 to 8 Ohms.
 One reed switch lead to the other.....either low res. 1-10 Ohms or a total open depending on the position of the magnet and reed switch.
 Any lead to ground.....total open or >20 megOhms
 Either motor lead to either reed lead.....total open or >20 megOhms

VOLTAGE TEST OF THE RC2800 ONLY

Note: these voltages only appear for a second or so when no rotator is attached. You must also PROGRAM P5 TO 9 temporarily to get non pulsed voltage.

Terminal #1 to #2 (Motor voltage).....45 vdc + or - when pushing the CW or CCW buttons.

Terminal #5 to #6 (reed sw. voltage).....11.3 vdc when pushing the CW or CCW buttons.

Terminal #1 or #2 to case ground.....45 vdc

VOLTAGE TEST WHEN OR2800 IS RUNNING AT SPEED 9

Terminal #1 to #2.....30 to 35 vdc

Terminal #5 to #6.....pulsed 11.3 volts (sq. wave)

CWR
AL
3

REAR PANEL WIRING

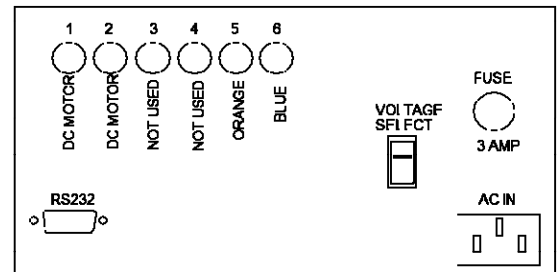

UNUSED WIRES IN YOUR CABLE CAN BE PARALLELED WITH THE MOTOR LEADS FOR MORE MOTOR TORQUE. WHEN USING BELDEN 9405 OR EQUIVALENT. TIE THE GREEN, BROWN, AND BLACK (MOTOR) LEADS TOGETHER. TIE THE YELLOW, RED AND WHITE (MOTOR) LEADS TOGETHER.

ROTATOR WIRING DIAGRAM

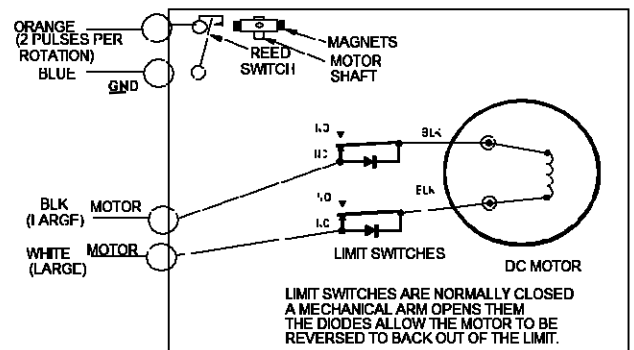

WARNING:

MOTOR VOLTAGES CAN CAUSE DAMAGE TO THE PULSE COUNTING REED SWITCH. THIS CAN OCCUR IF THE JUNCTION BOX IS WIRED INCORRECTLY. PLEASE CHECK YOUR WIRING CAREFULLY BEFORE CONNECTING THE CABLE TO THE RC2800PXAZ CONTROLLER

OR2800PXAZ CABLE INTERCONNECT TERMINAL HOUSING UNIT

This unit is a replacement for the original Conxall 7 pin connector. The accompanying sketch shows all the parts in an exploded view. Assembly should be self explanatory.

This terminal block allows easy field connections and easy access for trouble shooting and voltage measurements at or near the rotator. The housing has a sealing cover and the cable grips are also plastic and form a good seal at the exterior to the housing and where the cable enters. Even so as we all know Mother Nature finds ways to get moisture inside. We recommend you take added precautions based on your personal environment to seal around the cable grips and where the cables enter the cable grip. RTV sealant works well if placed on the mating face just prior to grip installation on the housing. Then tighten the grip onto the nut inside the housing. Once the cables are installed and all connections completed with the cover on, then the cables can be sealed with coax seal, etc.

Six terminal positions have been provided. This unit can replace any existing connector on an older OR2800 AC unit with 3 motor leads and two reed switch leads. The order in which you place your leads is up to you but logically it makes sense to duplicate the wiring on the rear panel of the RC2800 AC or DC control unit.

We have provided a terminal block for wire sizes up to #12 AWG. Since most rotator cables have at least 8 wires, it is advantageous to double or triple up the unused wires to get the most power possible to the rotator, particularly on runs over 250 feet..

If you have an OR2800 AC rotator, (3 motor leads) pair up the Green wire with the Large black wire and insert both into one end terminal position. White and Yellow can be paired and inserted into the next position. Red and Brown can be paired to complete the motor leads. The other two leads, normally Orange and Blue, are the reed switch leads and since only 5 mills of current flow when the reed switch closes, there is no need to pair up to reduce voltage drop. Connect the Orange wire in terminal [position #5 and Blue in the last position, #6 Note: your colors may vary. Use two of the smallest wires for the reed switch leads. These are the Orange and Blue leads coming out of the rotator. Black, White and Red are the motor leads from most older AC units.

If you have an OR 2800 DC unit, White and Black are the motor leads coming from a DC OR 2800. In your long cable run, Black, Green and Brown can be twisted together and inserted in the end terminal position. White, Yellow and Red can also be twisted together and inserted in terminal position #2. The remaining Orange and Blue wire can be inserted into terminal positions #5 and #6 respectively.

WIRING THE TERMINAL BLOCK:

Sometimes it may be easier to wire into the terminal block while it is above the housing. Remove two of the sub plate mounting screws on the long side of the housing. Loosen the other two screws and slide the sub panel and terminal block out of the housing. Strip off about 3" of

OR2800PXAZ ASSEMBLY MANUAL

the cable jacket and insert in into and through one of the cable grips so you have plenty to work with. Strip off about 1/4" to 5/16" of insulation on each wires to be used. Twist the bare leads together and insert into the terminal holes and tighten. Once one cable is done, then do the same thing with the other cable and wires. When all the leads are in place and tightened securely, replace the sub plate and tighten the 4 screws holding it down. Pull back the excess cable and make sure the outer jacket of each cable is well into the cable grip. Tighten each cable grip until the cables won't slip and the seal is complete around the cable. Smaller cables may have to be enlarged with tape so the cable grips can do their job. Install the cover and tighten all 4 screws evenly to create a good seal.

MOUNTING THE HOUSING:

The mounting plate is provided so the housing can be mounted on a tower leg using a Unicradle. This mounting is optional and the plate is optional. The four holes in the hosing can be used for other mounting methods. The holes are blind and will not affect the integrity of the housing.

CABLE ROUTING:

Whenever possible route cables down and away from the housing. This prevents water from running down the cable and finding its way into the housing. Form 'Drip Loops' in the cable so water can run away from the housing and then drip off the cable.

OR2800PXAZ POSITIONER: CABLE INFORMATION

Proper cable size is necessary to minimize voltage drops that occur with long runs of cable. The following chart indicates the correct gauge of wire that is recommended for various lengths of cable. **NOTE: Voltage drop is critical for terminals 1 and 2 for the DC motor.** Terminals 5 and 6 are for the digital pulse feedback and wire size is not critical.

LENGTH OF CABLE (control box to positioner)	—MINIMUM GAUGE—	
	Terminal / Pin 1, 2	Terminal /Pins 5, 6
125 Feet* (38M)	#18	#22-24
125-200** 28-61M)	#16	#22-24
200-300 (61-91M)	#14	#22-24
300-450 (91-137M)	#12	#22-24

*Belden 8448 or equivalent **Belden 9405 or equivalent

We recommend Belden 9405 or the WIREMAN equivalent. The WIREMAN also has produced a special OR2800 cable just for long runs of 250 to 600 feet. The Cable is 2 #12 wires and a shielded pair of #18 gage wires with a bare drain lead. Belden 8448 or equivalent can be used for cable runs of 125 feet or less.

NOTE: Occasionally Belden reverses the wire sizes of the red and white wires.

HINT: When combining conductors note that when two wires of equal gauge are in parallel the new equivalent gauge is determined by subtracting 3. For example, two 16 gauge wires in parallel is 16 minus 3, or 13 gauge.

PREPARING THE CABLE AND THE TERMINAL HOUSING

The OR2800PXAZ Positioner has a 5-6 foot cable pigtail. A terminal housing or box is supplied and should be placed at a convenient location either up on the tower near the rotator or at the base of the tower which allows for rotator control by the RC2800PXAZ from the base of the tower. This is handy for troubleshooting, installation and maintenance of the antenna system. Prep the cable leads by removing about 3" of the outer jacket. Strip about 1/4" of insulation off each lead and solder tin the lead if possible. Assemble the housing as shown on the drawings.

OR2800PXAZ ASSEMBLY MANUAL

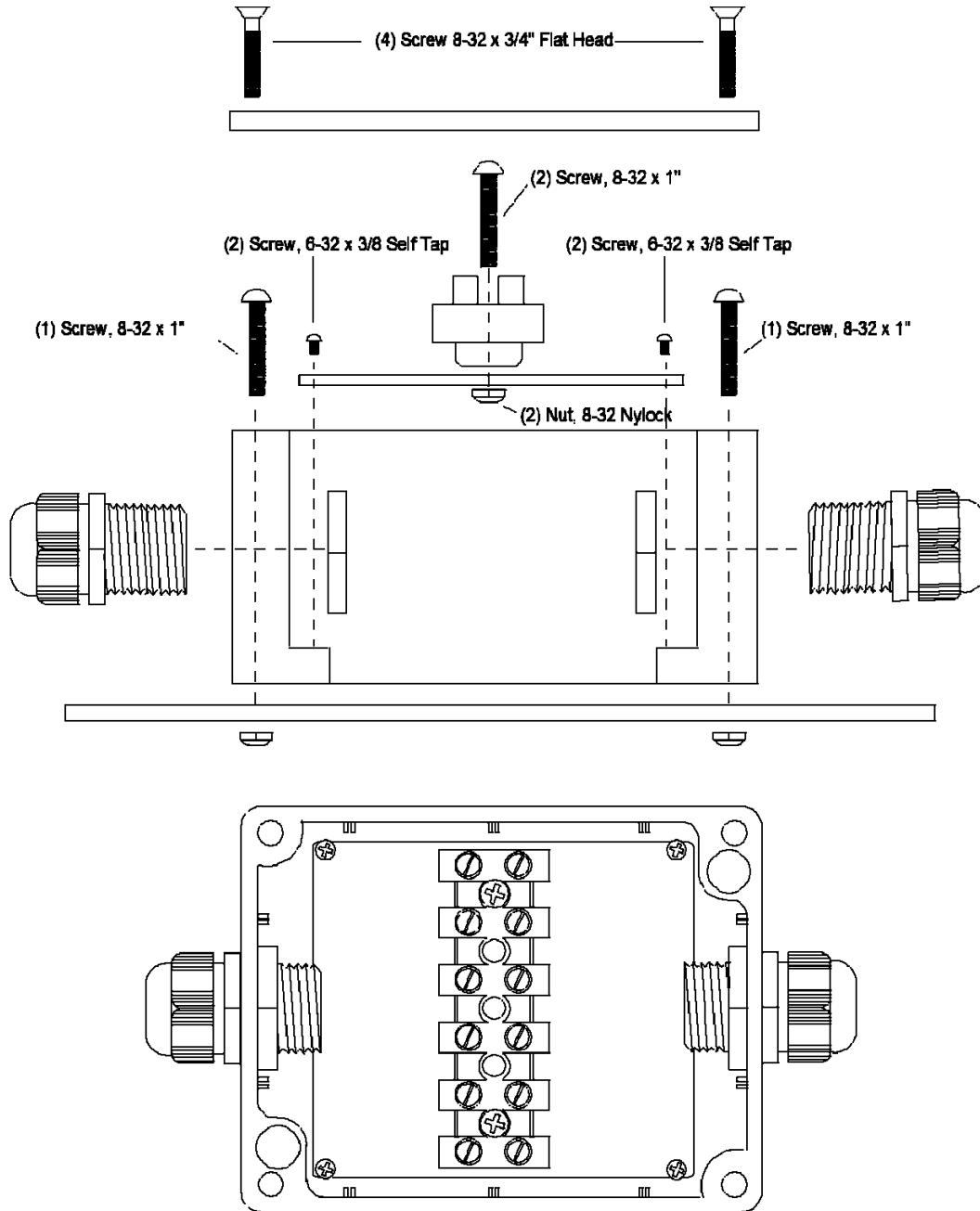

PARTS LIST:

Enclosure W/Lid	1	Nut, 1/4-20	2
Terminal Block (6 pos)	1	Washer, 1/4 Split Ring	2
Plate, .125 x 3 x 3.875	1	Screw, 8-32 x 1	4
Plate, .125 x 3 x 6.5	1	Nut, 8-32 Nylock	4
Cord grip W/Nut	2	Screw, 6-32 x 3/8 type F	4
Uni-Cradle (M2AMC0070)	1	Hardware bag from Bud	
U-bolt, 1/4-20 x 2" (14427BNF)	1	Box kit AN-1304	1

OR2800PXAZ POSITIONER HARDWARE AND DIMENSIONS

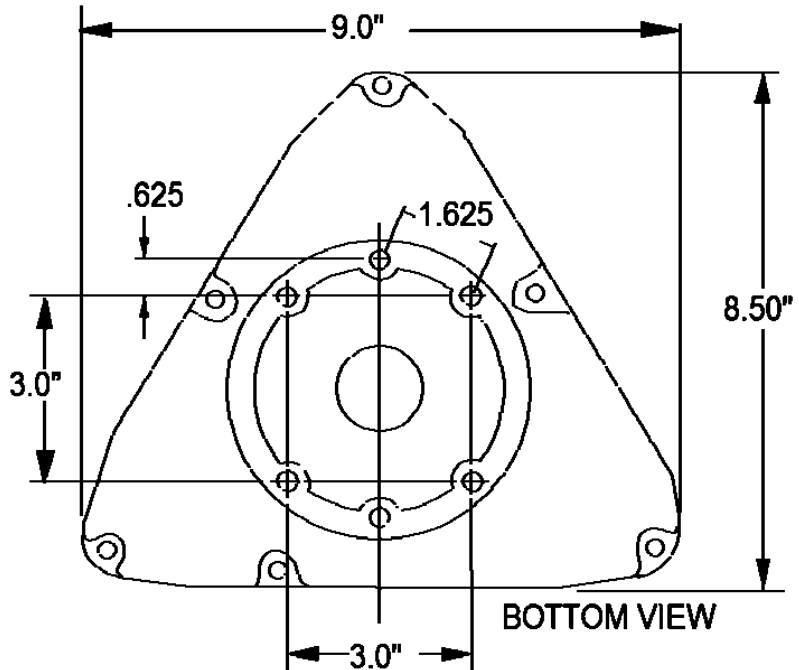

NOTE: FOR MAST DIAMETERS
OVER 2-1/2" CONTACT
M2 FOR LONGER BOLTS

3/8-24 X 4"
BOLT & FLATWASHER-12X
& LOCK NUT-6X

CENTER GUIDE: (OPTIONAL)
USED TO KEEP MAST
CENTERED. PLACE IT
OVER THE BOLT AND
SPACER.

1/4-20 x 1-1/4" BOLT
1/4" SPLIT RING LW
1/2" X 1/2" SPACER

TOP PLATE
SPLINED SHAFT
AND HUB

3/8-24 X 2"
BOLT, FLATWASHER
LOCK NUT - 4X

CAUTION

TIGHTEN CENTER BOLT COMPLETELY!
THIS BOLT LIFTS THE SHAFT & OUTPUT
GEAR TO THE PROPER OPERATION HEIGHT
INSIDE THE POSITIONER. WITH THE SPACER
IT ALSO FORMS A LOOSE BEARING THAT THE
CENTER GUIDE USES TO STAY CENTERED.

3/8-24 x 3/4" BOLTS,
SS FLATWASHER AND
LOCKWASHERS
QTY 6



OR2800PXAZ POSITIONER PACKING/PARTS LIST

DESCRIPTION	QTY
OR2800 GEAR BOX (SAOR2800).....	1
MAST CLAMP (M2AOR2820).....	2
RC2800PX/AZ CONTROL W/ POWER CORD(RC2800PXAZ)	1
TERMINAL HOUSING KIT(FGOR28TB).....	1
HARDWARE BAG(SAOR28HWK).....	1

HARDWARE BAG CONTENTS:

DESCRIPTION	QTY
BOLT, 3/8-24 X 4 GRADE 5 , ZP	6
FLAT WASHER, 3/8, ZP	16
FLAT WASHER, 3/8 SS	6
NUTLOCKING 3/8-24, ZP	10
BOLT, 3/8-24 X 2, ZP	4
BOLT, 3/8-24 X 3/4" SS	6
LOCKWASHER 3/8 SPLIT RING SS	6
CENTER GUIDE BLOCK, ALUMINUM.....	1

12 Month Limited Warranty

This warranty gives you specific legal rights. You may also have other rights which will vary from state to state or province to province.

M² warrants the OR2800PDC Positioner and Control Unit against defects in materials and workmanship for a period of 12 months from date of purchase. During the warranty period, M² will, at its option, either repair or replace products or components which prove to be defective. The warranty shall not apply to defects or damage resulting from:

- improper or inadequate maintenance by user
- unauthorized modifications or misuse
- improperly prepared installation site
- accident, abuse, or misapplication
- normal wear

M² specifically does not warrant this product for any direct, indirect, consequential, or incidental damages arising from the use or inability to use the product. Some states or provinces do not allow the exclusion or limitation of liability for consequential or incidental damages so the above limitation may not apply.

In the event repair or replacement are necessary, purchaser shall contact M² for return authorization. In many cases this contact can simplify and expedite the repair / replacement process and help reduce costs and downtime.

The purchaser shall be responsible for packing the product properly for return and for charges to ship the product to M². Always include with the shipment a statement detailing the problem / failure and any other pertinent observations. Insuring the product for shipment is recommended. Use the original packing materials whenever possible. M² is responsible for charges to return the repaired / replacement product only where warranty service is involved.

M² ANTENNA SYSTEMS, INC.

4402 N. Selland Ave.

Fresno, CA 93722

(559) 432-8873 Fax: 432-3059

www.m2inc.com Email: sales@m2inc.com