

DEM 9 CM Transverter Kits
3456-144CK, 3456CK, 3456BK and 3456K

Specifications

Frequency:	3456 MHz. = 144 MHz.
Noise Figure and Gain:	<2.0 dB nom. > 20 dB Gain
Power Out 3456-144CK:	1W nominal
Power Out 3456CK, BK, or K:	> 40mW
IF Power Input (model dependent):	1 mW to 10 W with TC
DC Power 3456-144CK: (1 W Kit)	10 - 15.5 VDC @ 1.0 A
DC Power 3456BK: (40 mW)	Regulated 9.0 VDC @ 300 mA.
DC Power 3456CK: (40 mW)	10 - 15.5 VDC @ 500mA
DC power 3456K: (40mW)	Regulated 9.0 VDC @ 500 mA

Preliminary:

The 3456-144CK is a complete kit that will produce > 1 watt output on 3456 MHz. with up to 10 watts of drive on 144 MHz. It is exactly what we use to produce our DEM3456-144. It consists of 3 separate boards kits, the transverter PCB kit, (the 3456BK), the DEM TC IF switch kit, and the A32 synthesizer. A hardware kit and the 1 watt PA kit finish the 1 watt version. The DEM TC enables the use of any 144 MHz drive level up to 10 watts, provides the regulated +9VDC, and supplies all of the switching voltage functions including a TR switch control. The A32 synthesizer (which replaces the DEM MICRO-LOK) is now the standard LO that drives the multiplier stage of the transverter. This synthesizer has the ability to have its frequency changed with a switch to enable the transverter to operate on other portions of the band or to use a different IF frequency in the 2M band. The A32 requires an external 10 MHz source unless the internal 10 MHz clock option (OPT-I) is ordered. All of the circuit boards have been engineered for a regulated 9 Volt operation for stable operation at home or for portable operation. After completion, you will just need a 3456 MHz. RF Transfer Relay, (a WTR option is available) an antenna, and a 2 meter IF transceiver of 10 watts or less to get you on the air!

The transverter may be ordered as a low power (40 mW max) kit as the 3456CK. It is the same as the 3456-144CK with the enclosure but without the PA components. A board kit only version without the enclosure and hardware is called the 3456BK. It is the 3 board basic kit. The transverter board kit is the 3456K. It will require a 1 GHz range LO. The PCB alone for you own projects may be ordered as the 3456PCB

Additional Options:

Additional options may be implemented depending on your requirements. You may use your own enclosures or oscillators and frequency combinations (If you have the 3456K and BK). The transverter is designed with this in mind. The DEM TC controls all switching functions DC and IF. If a lower system noise figure is desired, there is a 9 cm PHEMT preamplifier available. It is part number 9ULNAK (PC board kit) or 9ULNACK (complete kit with enclosure and connectors.) As a kit, the multiple frequency option is included with the A32. But unless you have a 10 MHz source, you will need the OPT-I option to operate the transverter.

Assembly Considerations:

With all transverter kits except the 3456BK, assemble the DEM TC per their provided documents and test individually. The A32 may have its frequency selected using the matrix provided with its document. It's output power is preset to drive the LO multiplier of the transverter



at the correct level but could be tested with a 9 volt supply voltage. This will verify the "LOC" circuit and whatever 10 MHz source is utilized. The frequency can be checked and the 10 MHz source trimmed up.

The TCK operates depending on the IF level required. A maximum of a 10W, common or separate IF input may be used by adjusting the built in attenuator values or bypassing the IF switch for split IF transmit and receive operation. Unregulated voltage may be supplied to the TC. The regulated 9 VDC is then available from a common connection on the TC board. Connection points are shown for AUX voltages such as TX LED, +9V, VRX and VTX on the TC board wiring diagram in this document. A RX gain stage provision is included on the TC board but is not recommended to use unless you have an excessive IF coax length.

Receive Assembly Options: (Refer to component placement diagrams for details. After a decision is made, mark your component placement diagram to indicate the changes).

The receive conversion gain of this transverter in stock form could be as much as 24 dB. You may wish to install a Low noise amplifier to reduce the system noise figure such as the DEM 9ULNA. The following 5 examples and recommendations will assume the mentioned preamp to have 16 dB gain and a 0.7 dB Noise figure.

Example 1. If the preamp is to be used directly connected to the transverter, do not install U1, R1 and R2. Place a wire jumper across the U1 and R1 position. Solder this jumper directly to the circuit board as if it was part of the transmission line. No bumps please!

Example 2. If a mast mount preamp is used and the length of coax used between the preamp and transverter has up to 6 dB loss, you may not have enough receive system gain if U1 is removed. In this case, it is suggested that the MGA86576 should be installed in the U2 position. This will utilize the filters in the transverter (for out of band interference) and provide enough gain to overcome the loss of the mixer. When doing this, the correct bias resistor should be installed. There is an optional 200 ohm resistor in the kit and it should be used for R4. Then follow the instructions in Example 1.

Example 3. If a mast mount preamp is used and the loss of the coax between the preamp and transverter is between 6 and 12 dB, the extra ERA-1 should be installed in the U1 position. A jumper should be installed in the R1 position and R2 should be replaced with a 130 ohm resistor. Then install a jumper for R3. U2 and R4 should be installed as normal.

Example 4. If there is more than 12 dB loss in the coax between the preamp and the transverter, reverse the positions of U1 and U2. This is a strange set-up but the system noise figure is already degraded because of the coax loss and any improvements in the gain of the transverter will not improve the total system noise figure. For this reason, if excess gain is used before filtering, there may be an increase of out of band interference occurring. This set-up will eliminate as much out of band interference as possible yet maintain enough system gain. After U1 and U2 are reversed, replace R2 with a 130 ohm and use a jumper for R3. Then use the optional 200 resistor for R4. Install a jumper for R1. It is then recommended to try to increase the gain of the external preamp. If by doing so, it degrades its noise figure, it will still improve the systems noise figure. BUT!!-If you increase the gain by as much as the loss of the coax, (adding another preamp) do not install a MMIC in the U1 slot.

Example 5. If you feel that you require as much receive gain as possible, and use a mast mount LNA in front of the stock transverter, install a band pass filter between the LNA and the transverter.



LNA's do have a wide band response and the MGA86576 (U1) has over 20 dB of gain from 1-6 GHz. It would be possible to have out of band signals amplified by as much as 40 dB before filtering if an external filter is not used! If a system like this is used without a filter for portable use at most mountain top locations, it would be a high probability that the receive system will be degraded. In a densely populated microwave environment, such as a mountain top, a preamplifier may hinder your receive signals. Be prepared to remove your preamplifier if interference persists!

Transmit Assembly Options: (Refer to component placement diagram for details and indicate the changes made to suite your requirements before assembly.)

If you are planning to use this transverter to drive a TWT type power amplifier or low level solid state amplifier, do not use the 1 watt option in the 3456-144CK. In the 3456-144CK, there is a provision to adjust the TX output power level with a IF attenuator. Even if this is set correctly, the 1 watt power amplifier could oscillate and produce a signal strong enough to destroy the TWT. The 1 watt transverter may still be assembled and tested, but if using a TWT, use the low power option of the transverter. Disconnect C31A and R23 after testing the 1 watt section and Install C31B. This will bypass the 1 watt stage and then may be operated without damage. Even with the standard MMIC line up used in all kits, there should be a minimum of 40 mW (+16dbm) of output power. This power may still not be low enough for a TWT. If not, install a attenuator pad on the input of the external amplifier or install a jumper for U11. This should lower the maximum power to +5 dBm and will also improve the local oscillator leakage that most TWT's would amplify anyway!!! The output power level could then be adjusted down to -15dBm with the TXIF adjustment if needed.

Review all of the components in the transverter kit and remember that the instructions assumes you have a complete 1 watt kit. If you have a basic kit, (3456BK) assembly the transverter board by the component placement diagram after it is attached to some type of enclosure (Brass walls). You may need to provide additional support to keep the transverter board from flexing before assembly. The flexing will break the surface mount components as you solder them! That doesn't sound like fun at all!

Assembly:

1. First check all MMIC mounting holes for excessive plating or lose trace material. The holes are drilled after the plating process. A Ohm Meter may not tell the whole story. A thin trace of copper may encircle the mounting hole. When the MMIC is placed in the hole and soldered to the circuit, the trace will short all leads to ground. This is a common problem with a circuit board of this type. Inspect and remove any trace that may exist with a sharp knife if needed. Do not cut into the ground area with the vias. When complete, if you have the 1 watt option, install and solder IC1 and R19. Then cut the excessive length leads off before mounting the board to the pallet with 10, 4-40 x 1/8" screws. If you are assembling the low power version, just mount the board to the pallet after inspecting the MMIC's mounting holes. Also notice that there are 4 holes in the mounting plate that are clearance holes. These are for mounting the plate to the housing. When complete, the PCB should be square on the pallet and may have some material hanging over the edge of the pallet. With a sharp knife, and using the pallet as a square edge, trim the board edges flush with the pallet.

2. Using the component placement guide, and after determining what options you may want, begin the component assembly. Start by soldering all MMIC's first. All MMIC's sit down into a hole

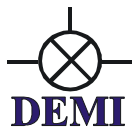

squarely except for U1. Be sure that they are flat!!! Align the dots of the MMIC's per the component placement diagram. When soldering, avoid solder bridges between input or output leads and ground. After soldering, check input and output leads of MMIC's for a short to ground with ohm meter. If any shorts are found, wick off excess solder from shorted lead and check again. Re-solder if needed.

3. Next solder the passive surface mount components. Pick an area on the circuit board and assemble per the component placement guide. Some capacitors and resistors share the same pads. Solder the shared pads last by attaching the component to the non-shared pad first. Make sure all components are down flat after soldering the first side so they don't fracture when the second side is soldered. If you plan to test the Local oscillator power output of the transverter board, install C7 on the LO test pad.
4. After reviewing all soldering and component placement, use the rear panel as a guide to trim the Teflon on the SMA connectors. Trim the Teflon of the SMA's flush with the panel then attach the SMA connectors with the 3-48 screws to the panel and pallet (long screws go into the pallet!) Tighten the screws and be sure that the Teflon does not extend beyond the panel or creates a gap between the panel and the plate. If there is a gap, remove and re-trim the SMA's , then re-attach. Solder the center pins only after the screws are tight!!!! Now install the BNC and RCA connectors. Attach 1000pF bypass capacitors on the 13.8VDC ,PTT and AUX between the RCA connectors and ground lug bolted to bottom of pallet. Pick a taped screw hole and use 4-40 x 1/8" screw to attach the ground lug.
5. Attach bias wires to VRX, VTX and +9 through the bottom of the pallet clearance holes. This is done by pulling the wires through the holes indicated on component placement diagram, strip and tin the ends, then solder the wire leads to the solder pads. Extend the other ends of these wires 2 inches past the mixer end of the pallet. Now attach 3 wires to all off the RCA connectors so that all wires extend 4 inches past the mixer end of the pallet. Mark all of the wires with some kind of identity or use a ohm meter to identify them after the pallet is assembled into the housing.
6. Mount the transverter pallet to the bottom half of the enclosure (half with 7 holes). Install the 4-40 x 3/8" screws, but do not tighten. Then using the panel screws, attach the rear panel to the housing. Be sure that all of the wires are out from under the pallet and none are being pinched and after the pallet alignment is checked, tighten all screws. Install the #4 standoffs with lock washers to the 2 remaining holes in the housing.
7. Complete the final wiring by using the TC **installation** instructions. Be sure to make all wire connections to the TC from the bottom side and coax connections on the top side. Review the **Operation** instructions of the TC before going on to Step #8.
8. After testing the A32 (if you chose too), attach a 6" piece of coax on the RF OUT of the A32 and a 6" piece of Teflon wire to the 6-12+ input. Now mount the A32 component side down on the other half of the enclosure with 4-40 x 3/16" screws. (see PCB and enclosure mounting diagram). Align both housing halves as shown. Then attach the Teflon wire to the +9 connection on the TC and attach the coax to the LO input of the transverter. Keep all connections as short as possible and trim if needed. Then If using an external 10 MHz. source, connect a 6" coax from the 10 MHz REF IN to the BNC connector on the rear panel of the transverter. Then, follow the A32 instructions or the TC document for connecting the "LOC" light and the multiple frequency switch if you desire to install.



After the assembly is complete, re-check for any loose wires, connections, or missing parts. Also review your custom configurations if any. For testing, a voltmeter and a 144 MHz. transceiver is required and a microwave power meter and signal generator are optional. Again, the further test Instructions assume a complete 1 watt kit !

Testing Transverter Receive:

Place unit as shown in the PCB and Enclosure Mounting diagram Connect a supply voltage to the 13.8VDC connector. Toggle the switch on and off to check for LED being lit. If OK, leave switch in the "ON" position and verify the 9VDC regulator's operation by checking the voltage or looking for the "blinking" blue LOC LED or a "Solid Lit" LOC light of the 10 MHz source is either connected or operating on the A32 board. If you suspect the +9VDC supply line is being pulled down from the TC, to troubleshoot, isolate which board is the problem by disconnecting the +9VDC supply wires one at a time. If not, there should be 9 volts at the +9 connection on the TC board and on the +LO points on the transverter. Then verify voltage on the +RX point of the transverter. If the 9 volts check, verify the RX and the LO test voltages on the transverter from the chart below.

TEST	LOCATION	VOLTAGE referenced to Ground
RX 1	Junction of R1 and R2	6.0VDC ± 1V, Not to exceed 7.2VDC!!!!
RX 2	Junction of R4 and U2	3.5 VDC ± 1V
RX 3	Input of U2	2.5 VDC ± .5 V
RX 4	Junction of R6 and U3	3.5 VDC ± 1 V
RX 5	Input of U3	2.5 VDC ± .5 V
RX 6	Junction of R7 and U4	3.5 VDC ± 1 V
RX 7	Input of U4	2.5 VDC ± .5 V
RX 8	Junction of R9 and U5	3.5 VDC ± 1V
RX 9	Input of U5	2.5 VDC ± .5 V
-----	1 Watt Option Test	1 Watt Option Test
RX 10	Junction of R22 and C34	Adjust R19 to produce -1.5VDC (negative voltage!)

NOTE: If R22 and C34 voltage cannot be obtained, do not proceed with the TX Testing!!

Troubleshooting Receive:

If any of the above voltages are out of specification, check all supply voltages and bias resistors for correct value. Open circuits are the most common problems. Also check MMIC's for shorts to ground (input or output leads). MMICs have a operating current. This results in a voltage drop across the bias resistors. If there is no voltage drop, then there is no current drain! If there is a complete voltage drop, then there is too much current drain! Check the circuitry for problems and suspect a defective MMIC last. It is very Rare!!!

Testing Transverter Transmit:

After the RX and LO sections of the transverter check out, a 50 ohm load of some sort should be connected to the TXRF connector. If you are testing a 1 watt unit, be sure of the power dissipation of the load. Place the transverter into transmit by enabling the PTT (either positive voltage or connect to ground depending on the set-up chosen during assembly). Verify that +9 volts (referenced to ground) is connected to the +TX points on the transverter board and that it switches off when the PTT control is disabled. Also verify that the +RX disables when the +TX is enabled and the +LO voltages do not change. If everything checks, verify the Transmit test voltages on the following chart.



TEST	LOCATION	VOLTAGE referenced to Ground
TX 1	Junction of R23 and C29	9.0VDC \pm 0.5V
TX 2	Junction of R23 and C32	0.500 Volts less than TX 1 (adjust R19 to obtain)
TX 3	Junction of R18 and C25	5.0 VDC \pm 0.5V
TX 4	Input of U11	2.5 VDC \pm 0.5V
TX 5	Junction of R10 and C17	3.5 VDC \pm 0.5V
TX 6	Input of U6	2.5 VDC \pm 0.5V
TX 7	Junction of R13 and U7	3.5 VDC \pm 1V
TX 8	Input of U7	2.5 VDC \pm 0.5V

Troubleshooting:

Just like in the RX and LO section, If any of the above voltages are out of specification, check all supply voltages and bias resistors for correct value. Open circuits are the most common problems. Also check MMIC's for shorts to ground (input or output leads). Always suspect a defective MMIC last. It is very Rare!!! If TX2 will not adjust for a voltage drop across R23, be sure that the negative voltage is adjusting correctly. The closer the negative voltage gets to ZERO, the more voltage will be dropped across R23. **Do not set R19 for Zero Volts!!!**

Setup, Interfacing and Operating:

It is now assumed that if you have assembled this kit, you have a reasonable idea of how you wish to interface this transverter to your 2 meter IF transceiver. If not, here are a few pointers along with some general guidelines for further enhancements:

1. You will need to "hard-key" this transverter. It is not RF senesced! If you wish to have your transceiver key the transverter, you will need to use the auxiliary contacts or a positive voltage on transmit generated by your IF transceiver. Some 144 MHz. transceivers have this built in but some transceivers don't. You may need an internal modification in your transceiver to get this.
2. The transverter in its stock form will only safely accept a maximum of 10 watts input if the TC is used. If you assembled the transverter without the TC, the transverter will not tolerate more than 20 mW of 144 MHz. directly into the mixer. If your transceiver has more than the tolerable amount of drive, you will need to devise a attenuator scheme that places the attenuation in line while in transmit. If this is not possible, do not proceed with testing the transmit section without an attenuator. If you cannot devise a scheme to remove the attenuation during receive, a receive IF gain stage may be added to the IF switch to compensate for the additional attenuation in the IF line.
3. RX and TX levels may change when the enclosure is completely assembled. Please take this into consideration when adjusting final levels and retest after the assembly is closed if using any of the complete kit versions.
4. If you intend to remotely mount this transverter, test the transverter with the cabling that will be used in the instillation before installing.

Testing:

The success of your transverter, if you lack test equipment beyond a Volt meter, depends on correctly verifying the test voltages and assembling and wiring the transverter's sub-assemblies with care. Be sure that there are no "Maybes" and re-check everything before continuing. After correctly interfacing the transverter to your 144 MHz. transceiver, power the transceiver on and set the controls to the normal operating receive positions including frequency. Be sure that

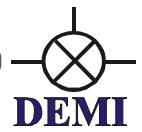

the transceiver is in either CW or SSB. Power the transverter on. The following assumes that you have assembled the transverter in its stock form and are using the TC. With a 50 ohm load on the receiver port, (signal generator, dummy load, antenna) some noise should be detected in the transceiver when the transverter is powered on and off. Adjust the RXIF gain control on the TC to a level that is just noticeable when the transverter is powered on and off. If a noise level cannot be detected, recheck all interface connections and transverter voltages in the receive mode. If the transverter is working correctly, (voltages, RF and IF connections, LO operation) there will be a noise floor increase unless you have installed an attenuator in the IF line without compensating for it on receive, or your 144 MHz transceiver is dead! If there isn't any noise present, please review your assembly and equipment.

When the receive is working correctly, the transmit section is then tested. Adjust the TXIF pot on the TC fully counter clock-wise. This is maximum attenuation. If the TC is assembled correctly, a maximum of 10 watts may be transmitted into the transverter. The transverter will start to saturate at 1 Watt output. Without a power meter, it isn't difficult to set the output power, it just that you will not know exactly what the output power level is. If you have a 1 Watt load on the TXRF connector, it will get warm when the transverter is transmitting (A clue that there is output!) You can then adjust the TXIF control by watching a current meter. Be sure that the transverter is on a separate power supply from the transceiver for this test or use your volt meter in a current meter function. Watch the current drain as you increase the TXIF drive level. As the power saturates, the current will start to drop off (ever so slightly!) Set the TXIF control so the current does not drop off. That's it! It is the same for the lower power model, it just has less current drain.

Of course, if you have a power meter, it will make setting the TXIF level and troubleshooting easier if needed. The low power version should be set around 40-50 mW output power. The 1 Watt level should be maintained. Any higher, the signal will contain extra harmonics that are produced by the mixer diode being saturated by the 144 MHz. transceiver. As for the receive, nothing beats a good on the air signal to determine how the receive section is working. A remote mounted signal source works great if nothing is on the air!

The Finish line!

Carefully, assemble both halves of the enclosure without pinching the wire and coax. Try to position the IF cable so that it doesn't lay on the filters of the transverter's PCB or fix it so that it is on the ground plane. If the IF cable lays on the transmit, receive, or LO filters, there will be a slight degradation in performance. The shield of the coax will de-tune the filters if it is in contact!! It is not serious, but it will degrade! Screw the remaining 4 panel screws in and re-test the transverter as before to verify everything is OK! If so, tighten the screws and it's ready to go! Please review the General Notes below and Have fun on the bands!!

General Notes:

1. Spurious response will change depending on the enclosure used. This transverter has been designed to have a -40dBc of all spurious responses during transmit in our complete kit enclosure. If your transverter doesn't make this specification, something is not assembled or adjusted correctly. Please verify assembly and verify all test voltages before taking on a re-engineering project!
2. All transverter circuits are designed to be used with 9 volt regulated source. Anything else needs different bias resistor values.

3. The TC IF switch may be used to control a TR switch. At stock levels, sequencing will not be required to provide basic switching functions.
4. The transverter may be mast mounted if minimal weatherproofing is accomplished. Be sure of your drive levels and voltage over long runs.
5. The transverter may be interfaced with other external power amps and pre-amps. If you have any questions please consult Down East Microwave.
6. The transverter is designed and may be used for any mode of operation at a 100% duty cycle. Switching times will not be as fast as digital modems in its stock form.
7. With the A32 synthesizer, you will be tempted to expand the frequency ability of the transverter. The only limit are the filters in the transverter. Dual frequency setup is possible for 3456/3400. Other frequency combinations may attenuate the incoming signals, and the LO filters will not allow enough drive for the mixers.

Rear Panel Diagram

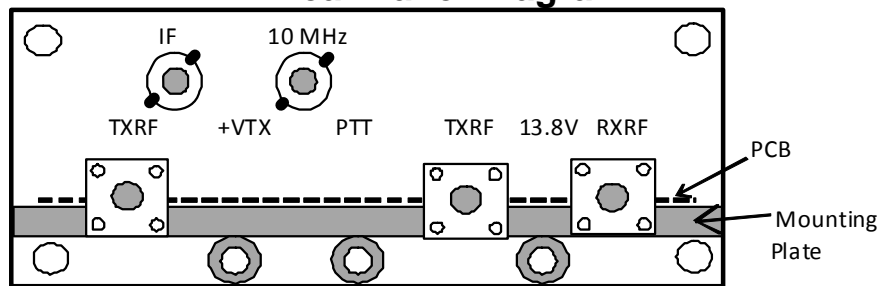

The 1 watt output version will have a extra SMA connector installed. The TXRF connector will be mounted by the RXRF connector so that a common SMA type relay may be connected to perform the TR function. The connector in the old TXRF position will be a dummy connector and will not be connected to any circuitry.

Enclosure and PCB Mounting

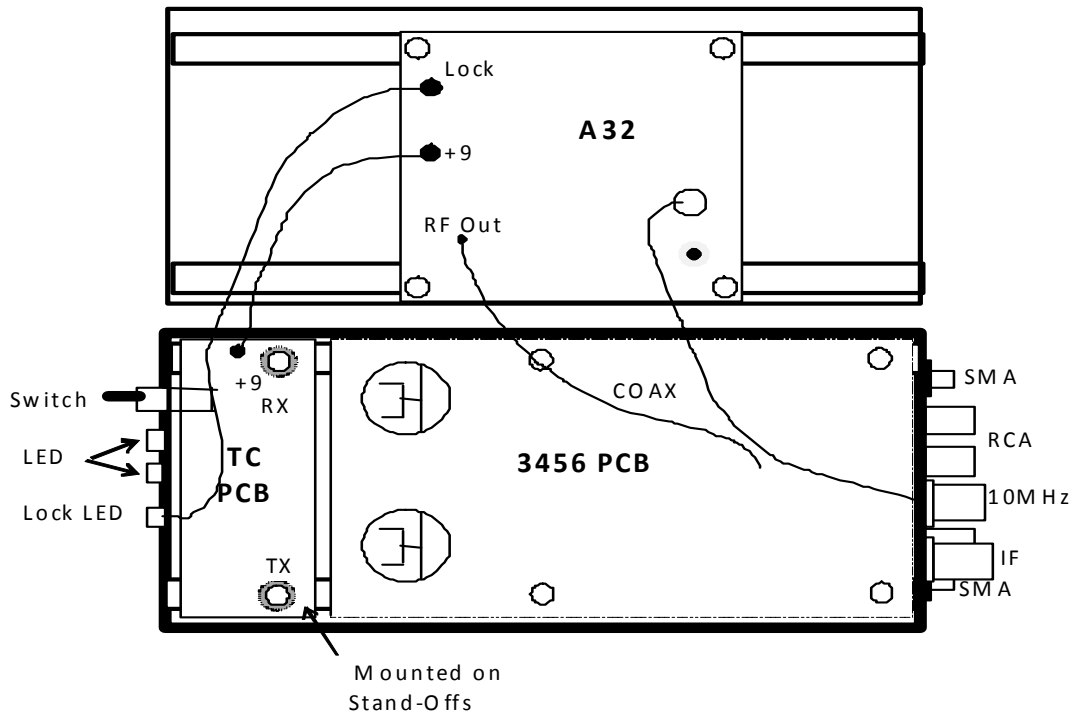

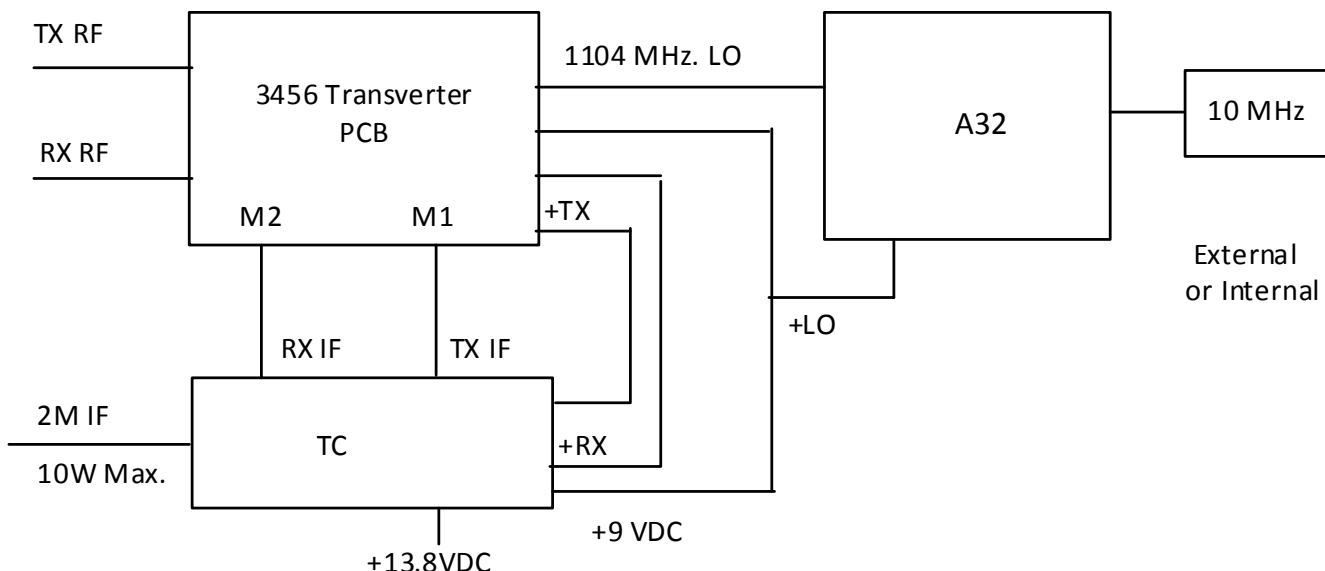

Wiring Block diagram

3456 Transverter Parts List

All components are Surface Mount components unless otherwise noted.

C1 8.2 pF ATC	C12 0.1 μF	C25 0.1 μF	R9 10 Ω	U6 ERA-1
C2 0.1 μF	C13 0.1 μF	C26 10 pF	R10 10 Ω	U7 ERA-1
C3 10 pF	C14 10 pF	C31A 10 pF	R11 130 Ω	U11 ERA-4
C4 0.1 μF	C15 0.1 μF	R1 10 Ω	R13 130 Ω	CR1 MA4E2054
C5 0.1 μF	C16 100 pF	R2 51 Ω	R18 130 Ω	CR2 MA4E2054
C6 100 pF	C17 0.1 μF	R3 150 Ω	R20 130 Ω	
C7 10 pF	C18 10 pF	R4 130 Ω	U1 MGA86576	
C8 0.1 μF	C19 0.1 μF	R5 51 Ω	U2 ERA-1	Optional ERA-1
C9 10 pF	C20 0.1 μF	R6 130 Ω	U3 ERA-1	" 200 Ω
C10 0.1 μF	C21 0.1 μF	R7 130 Ω	U4 ERA-1	" 130 Ω
C11 10 pF	C22 100 pF	R8 150 Ω	U5 ERA-2	

3456-144 Complete Kit Hardware Parts List

1- Machined Enclosure	3- RCA connector	3 - 4-40 x 1/4" screws	3- 1000 pF capacitor
2- Machined End Plates	1 - SPDT Switch SMD	2 - 4-40 nuts	3' #24 Teflon
8- Flat head screws	2- 4-40 x 1/4" standoff	2 - # 4 lock washers	4' #28 Teflon
2- BNC connector	5 - 4-40 x 3/8" screws	2 - #4 ground lug	30"- RG-188 coax
1- 3/8" hole plug	4 - 4-40 x 3/16" screws	6- 3-48 x 3/16" screws	1 - 1/4" thick pallet
3- SMA connector	12- 4-40 x 1/8"	6- 3-48 x 3/8" screws	

3456-144 PA SECTION

C27 0.1 μ F	C32 10 pF	R19 10K pot	Q1 FLL 177
C28 10.0 μ F	C33 10 pF	R21 51 Ω	2- sets of 2-56 screw & nut
C29 0.1 μ F	C34 0.1 μ F	R22 51 Ω	
C30 10 pF	C35 10.0 μ F	R23 1 Ω , 1Watt	
C31B 10 pF	C36 10.0 μ F	IC1 7660	

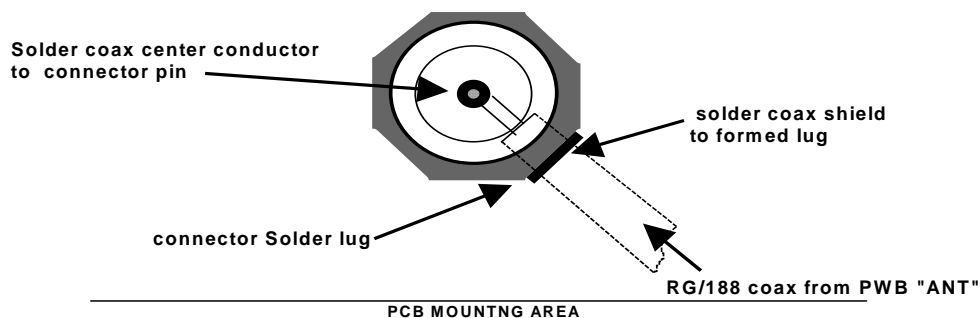

Installation of IF Coax on BNC panel connector

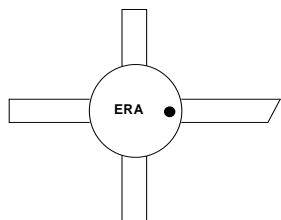

ERA MMIC

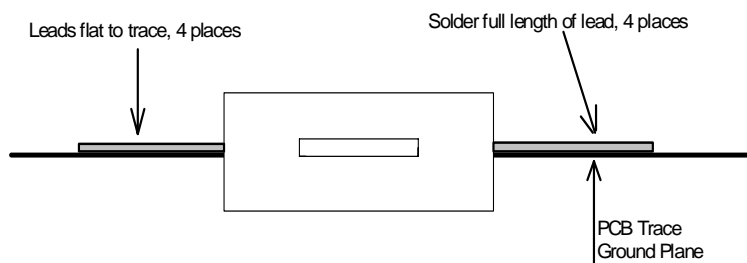

ERA MMIC mounted in hole of PCB

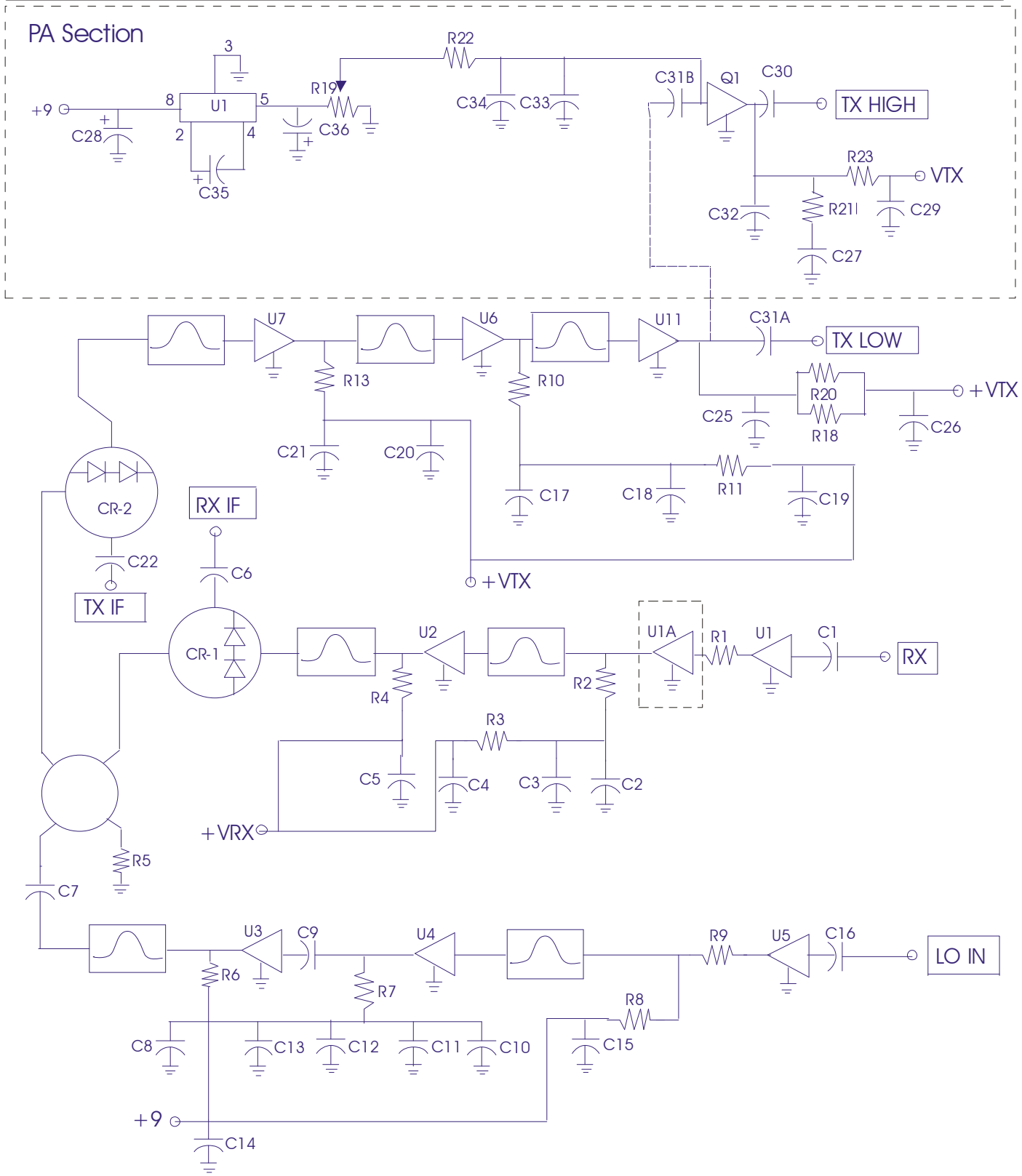

3456-144 TRANSVERTER SCHEMATIC

