

# Q5 SIGNAL VHF/UHF TRANSVERTERS

A Down East Microwave Product Manufactured by Q5 SIGNAL, LLC

## **Part Number L222-28CK and K Transverter Specifications**

Power Out Maximum:	Nominal 25 W linear
Noise Figure and Gain:	1.0dB maximum @ 17dB conversion gain minimum
DC Power Requirement:	11.5 - 15.5 VDC @ 6 Amp Max.
IF Drive Level Maximum:	Range Selectable between -20dBm and 25 watts
Keying Option with / without Sequencer:	PTT-L (to ground) or PTT-H (Positive Voltage)
User Installed Options:	IF Drive Sense, Cooling Fan, Sequencer

**Configuration Overview:** The VHF/UHF transverter line is designed to interface and operate with most High Frequency transceivers that are available on the market today. Since you choose to purchase a kit version, you may configure it to your specifications and interface it with your desired transceiver. This configuration may be changed or altered at any time if you desire to utilize a different transceiver or change your system's configuration.

**Part Number Verification:** All transverters contain the operating frequency within the part number, i.e., 222-28CK or K is equated to 222 MHz being converted to 28 MHz. Understand that the conversion is simple math. If you desire to operate on 222.100 MHz. with your 222-28, it will require you to adjust your transceiver to 28.100 MHz.

**Power Out Maximum:** The maximum **linear** output power indicated on this kit is 25W. This level should not be exceeded if linear operation is expected. The transverter may be capable of producing higher output power but is not recommended because of excessive heating that will interfere with its frequency stability while producing excessive "on the air" distortion products

**Noise Figure and Gain:** The noise figure and gain listed are nominal minimum requirements and all transverters will exceed these specifications if assembled and adjusted correctly. In utilizing the latest PHEMPT technology, we have designed the complete receive section of the transverter with extra filtering, diplexing, and gain management in mind complete with a RXIF gain control.

**DC Power Requirement:** The DC power requirement is listed and should be used as a guideline. Please include some "Buffer" in your power supply to eliminate voltage drop delivered to the transverter. Basically, do not utilize a 6-amp power supply for a 6-amp requirement transverter.

**RF Option:** The 222 Mhz. RF section may be configured with either a single port (Common RF) for both TX and RX or two separate ports, (Split RF) one RX and one TX. There is a PC board relay doing the Common RF switching. Once configured, the unit may be changed from Common to Split RF if the user desires. This will be covered in the manual.

# Q5 SIGNAL VHF/UHF TRANSVERTERS

A Down East Microwave Product Manufactured by Q5 SIGNAL, LLC

**IF Option:** The IF (28 Mhz.) configuration options may be set up as Split IF (separate TXIF and RXIF in/out lines) or can be configured as a Common IF. There is a relay that will switch the RX and TX in the correct direction and is controlled by the PTT circuit.

**IF Drive Level Maximum:** After configuration, the transverter will operate at its maximum output power with any drive level between -20dBm and 25 watts. The overall drive level range is determined by different attenuators and/or gain stages if required. The TXIF gain control with 15-20 dB of dynamic range will allow the user to tailor a specific output power less than maximum.

**Keying Option:** The keying options are either PTT-L or PTT-H. PTT-L requires a connection to Ground to transmit. This is the most common keying option. PTT-H requires a voltage between 1.7 and 17VDC to transmit. This option can also be placed on the IF coax if desired. If you desire the sequencer to be utilized, the PTT connection will go directly to the sequencer to key it. In turn, it will key the transverter on the last step of the sequence. Now doing so creates other caveats if you choose to use a High IF drive level (above 1/2W). This is covered in the next section.

**User installed Options:** The **IF Drive Sense** option should be installed for any Common IF drive level above 100 mW. This is a protection circuit that will prevent excessive IF drive levels from damaging the RXIF circuitry and the Mixer. When utilizing a high-level IF drive transceiver, the IF drive from your transceiver may be applied to the transverter at the same time as the PTT is energized. If the transverters sequencer is utilized, the transverter will be keyed last in the sequence. This would result in the high level IF drive being applied to the transverter's RXIF section which would cause damage. With the IF drive sense circuit installed, it detects the high-level drive and enables the TXIF attenuator. This protects the transverter's RXIF section and Mixer. It then holds and waits for the Transverter to "Catch up" in the sequence. This circuit will allow a user to key the sequencer circuit with the standard PTT circuit of a transceiver without having an issue or requiring external wiring and modifications to the transceiver's PTT circuit. This circuit will also protect the transverter in case the PTT circuit fails between the transverter and the transceiver. If the transverter is keyed directly with the PTT (sequencer is disabled) it will function normally. **CAUTION:** The IF drive sense circuit should not be used to key the sequencer because it will produce long delays between transmit and receive or chop off the beginning of a transmission. The transverter's IF drive sense was designed for protection only.

The **Cooling Fan** should be installed and used with the temperature sense circuit because it is crucial for frequency stability in digital modes. As the temperature increases the fan speed will increase to provide the additional cooling and frequency stability.

The **Sequencer** is a 4 step circuit that may be used to key any external devices and the transverter itself. It may be configured in any fashion and set up to switch external voltages such as a 24 VDC relay. The voltage may be run into the transverter through the AUX connector and switched through the sequencer.

# Q5 SIGNAL VHF/UHF TRANSVERTERS

A Down East Microwave Product Manufactured by Q5 SIGNAL, LLC

**The KIT Details:** This assembly manual calls out a reference to one or two picture numbers for most assembly procedures. The pictures can be found on our website in the “Product Manuals” section. It is a full copy of this manual with all numbered pictures at the end of the document in .PDF format and in color. You may download a complete copy of this document or just reference the pictures. You will find that the details offered in the pictures will aid any assembly instruction.

The following component list contains both pre-assembled components and components to be assembled by the kit builder which are in **Bold Print**. Verify that all components in **Bold print** are supplied in the kit. Some extra components are included. There may also be component values included in the kit not found on the list. These will be used in the testing section of the document. ALSO, because this is a board used for all transverters from 50 thru 432 MHz, there are some components installed on the circuit board that are not required for 222 MHz operation. They are labeled NA on the component list because they will have no function in your frequency specific version. It is suggested to Highlight the components on the component placement document that are to be installed as you inventory the values.

## 222-28 COMPONENT LIST

Resistor (R) values are in Ohms and are chips unless otherwise specified

R1 1K	R30 51	R43 470	R56 10K	R69 10K
R2-R17 NA	R31 12	R44 10K	R57 10K	R70 10K
<b>R18 39(1210)</b>	R32 51	R45 220K	R58 1M	R71 10K
R19 470	R33 1K	R46 1M	R59 10K	R72 1M
R20 330	R34 330	R47 10K	R60 220	R73 10K
<b>R21 150 ½ LEAD</b>	R35 220	R48 10K	R61 10K	R75 100
R22 51	<b>R36 1K POT</b>	R49 1K	R62 10K	R76 51
R23 470	R37 220	R50 5.6K	R63 1M	R77 1K
R25 12	<b>R38 1K POT</b>	R51 5.6K	R64 10K	R78 220
R26 24	R39 220	R52 22K	R65 220	R81 5.6K
R27 12	R40 220	R53 470	R66 10K	R82 5.6K
R28 51	R41 10K	R54 10K	R67 10K	R84 5.6K
R29 51	R42 10K	R55 10K	R68 1M	

All inductors (L) are in  $\mu$ H and are 1008 chip unless otherwise specified. “PW”=pre-wound or “HW”=hand-wound and utilize enamel wire. All inductors need to be installed in the kit unless specified as **OPT**.

L1-L4 NA	L15 4 Turns #18 3/16” dia. PW	L23 150
L7 33	L16 3 Turns #18 3/16” dia. PW	L24 220
L8 68	L17 6 Turns Small PW	L25 150
L9 68	L18 220	L26 330
L10 33	L19 56	L27 330
L11 1.0 $\mu$ H	L20 18	L30 1.0 $\mu$ H
L13 3 Turns #18 3/16” dia. PW	L21 1.0 $\mu$ H	L31 1.0 $\mu$ H
L14 4 Turns #18 3/16” dia. PW	L22 330	1.0 $\mu$ H Molded OPT

# Q5 SIGNAL VHF/UHF TRANSVERTERS

A Down East Microwave Product Manufactured by Q5 SIGNAL, LLC

All capacitors (C) are in pF and are chip unless otherwise specified. "E" = Leaded Electrolytic, "T" = chip Tantalum, Band is positive. NA components are indicated

C1 1000	C47 0.1 $\mu$ F	C69 0.1 $\mu$ F	C92 1000
C2 – 23 NA	C48 0.1 $\mu$ F	<b>C70 24</b>	C93 1000
<b>C24 1000</b>	C49 1000	<b>C71 8</b>	<b>C94 10 (OPT)</b>
<b>C25 24</b>	C50 1000	C72 1000	C95 1000
<b>C26 27</b>	C51 0.1 $\mu$ F	C73 1000	C96 1000
<b>C27 24</b>	C52 100	<b>C75 4.7 <math>\mu</math>F T</b>	C97 1000
C28 1000	<b>C53 100 <math>\mu</math>F E</b>	C76 0.1 $\mu$ F	C98 0.1 $\mu$ F
C30 100	<b>C54 15</b>	C77 0.1 $\mu$ F	<b>C99 4.7 <math>\mu</math>F T</b>
C31 100	<b>C55 18</b>	C78 1000	C100 1000
C32 0.1 $\mu$ F	<b>C56 15</b>	C79 1000	C102 1000
C33 NA	C57 1000	C80 1000	<b>C103 22 <math>\mu</math>F T</b>
C34 1000	C58 100	C81 56	<b>C104 4.7 <math>\mu</math>F T</b>
C35 - 38 NA	C59 0.1 $\mu$ F	C82 150	C108 1000
<b>C39 4.7 <math>\mu</math>F T</b>	<b>C60 4.7 <math>\mu</math>F T</b>	C83 150	<b>C112 100 <math>\mu</math>F E</b>
C40 0.1 $\mu$ F	C61 0.1 $\mu$ F	C85 150	C113 – C114 NA
C41 NA	C62 1000	C86 56	<b>C115 10 <math>\mu</math>F T</b>
C42 NA	<b>C63 2-6pF SMD Trimmer</b>	C87 1000	C116 1000
C43 1000	<b>C64 2-6pF SMD Trimmer</b>	C88 1000	C122 1000
C44 1000	C66 0.1 $\mu$ F	C89 0.1 $\mu$ F	
C45 1000	C67 0.1 $\mu$ F	C90 1000	
C46 1000	C68 1000	<b>C91 10 or 1000</b>	

## Solid State, Relays and Filter Components

CR1 MMBD914	<b>F3 222M-2 pole</b>	Q6 ATF33143
<b>CR3 MPN3404</b>	<b>F4 222M-2 pole</b>	Q7 PMBT3904
<b>CR4 MPN3404</b>	<b>IC2 PHA-1</b>	<b>Q8 MJD31</b>
<b>CR5 1N914 or 4148</b>	<b>IC3 MAR3</b>	Q9 PMBT3904
<b>CR6 1N914 or 4148</b>	<b>IC4 MAV11</b>	<b>Q10 MJD32</b>
<b>CR7 HP2800 SMD</b>	<b>IC5 RA30H2127M</b>	Q11 PMBT3904
<b>CR8 HP2800 SMD</b>	<b>IC6 PHA-1</b>	Q12 PMBT3904
CR9 MMBD914	<b>IC7 MAR6 (option)</b>	Q13 PMBT3904
<b>CR10 1N4000 type</b>	IC8 LM393	<b>Q14 MJD31</b>
<b>CR11 HP2800 SMD</b>	IC9 LM324	Q15 PMBT3904
CR12 MMBD914	<b>K1 D2n</b>	Q24 PMBT3904
CR13 MMBD914	<b>K2 G5Y or G6Y</b>	Q26 PMBT3904
<b>CR14 1N4000 type</b>	<b>K3 G5Y or G6Y</b>	<b>VR3 78L05</b>
CR21 MMBD914	<b>M1 SYM18H</b>	<b>VR4 78M05</b>
<b>F2 222M-3 pole</b>	Q5 PMBT3904	<b>VR5 78S09</b>

# Q5 SIGNAL VHF/UHF TRANSVERTERS

## A Down East Microwave Product Manufactured by Q5 SIGNAL, LLC

Verify all of the listed hardware is in the Hardware Kit.

### HARDWARE

(1) Heatsink	(1) #6 ground lug
(1) Back Panel of enclosure	(1) #4 Ground lug
(1) U-channel enclosure	(1) 50 Ohm load
(1) Bottom panel	(1) Switch
(7) Black 4-40 screws	(1) Green LED
(26) 4-40 x 1/4" screws	(1) Red LED
(12) Aluminum Shoulder Bushings	(3) BNC connectors and Hardware
(2) 4-40 x 1/4" threaded standoffs	(2) Type "N" connectors and Hardware
(3) 4-40 nuts	(1) RCA connector
(1) 4-40 x3/8" screw	(1) 9 pin connector and Hardware
(1) Brass shield for Power module (if required)	(1) NL2 connector
(2) 6-32 x 5/16" screws	(1) NL2FC connector
(1) 3/16" hole plug	(1) 1000pf disc cap
(4) 3/8" hole plug	Coax, 20"
(1) 5/8" hole plug	#24 gauge wire, 6 feet (Green)
#16 wire, 1.5" black, 2.5" color	(1) NTC Thermistor
(1) Fan	(4) 6-32 x 1-3/4" screws
(1) Fan guard	(4) Tie Wraps
Sleeving, 3"	(4) Rubber feet
Tube of thermal compound	5' of RED/BLACK Zip cord
Bundle of precut #26 colored wire	Power meter kit
(1) #6 flat washer	Synthesizer kit

### Circuit Board Assembly:

Refer to the component placement diagram and install all topside components that require soldering on the bottom side of the board. Install VR3, F2, F3, F4, K1, K2, K3, R36, R38, CR3-CR6, CR10 and CR14. Even though K2 (RF relay) and K3 (IF relay) are to make the common RF and IF connections, (combined TX and RX), separate TX and RX connections to both RF and IF ports can still be made after relay installation. BUT—you may leave both relays un-installed if you only desire separate RX and TX ports for the IF and RF connections. Be sure to heat the ground connections well before flowing solder on the filters and relays. Cut the excess from all leads flush with the board. **See Pictures 1 and 2**

Now examine the Bottom Side Board Assembly picture on the next page. It is suggested to complete all of the wiring on the bottom side. Some wires are for features that you may never utilize in your configuration but will provide ease of a configuration change at a later date if you decide to change transceivers. If you do not see the need for certain features, some of the wiring may be omitted. The signals are marked on the picture. The IF drive sense (three wires), and the wiring for the RF TR relay may be left out if those circuits will not be utilized. They could be added to the top side if required in the future. All other wire connections are required for full transverter function. Each marked wire shows its approximate length.

# Q5 SIGNAL VHF/UHF TRANSVERTERS

## A Down East Microwave Product Manufactured by Q5 SIGNAL, LLC

Find the long wind of #26 Green hook up wire, then cut, trim, tin, and install. It is best to cut the wire a bit long (1/4") and trial fit after soldering one end in place. If you are close with the measurements, the wires will fall into place as shown. If the wire is too long they may get pinched during the assembly of the board. One wire, the 9" 13.8V, is only attached at one end for now. Save the extra wire out of the 6' bundle for topside wiring.

After all wires that you wish to install are installed, (9 max) be sure none of the wires cross any of the bottom side solder connections of the filters, pots, and RF relays. This is to prevent any RF signals from coupling to the DC connections. The exception is the 1-3/4" TXON wire for the TR switch. It crosses under K1 which is a non-RF circuit relay. Also be sure that the wires do not cross any mounting holes. Then with a small piece of tape (any type), attach the wires as shown in the next picture being sure that the wires are laying flat on the circuit board. If you desire to attach other wires or configure the transverter differently, or desire to use any type of adhesive to hold wire in place, please do so. Just be sure to clear all mounting holes and exposed RF circuits and do not allow an excessive amount of adhesive to prevent the circuit board from attaching flat to the mounting hardware on the heatsink. A 1/8" clearance is required between the board and heatsink.

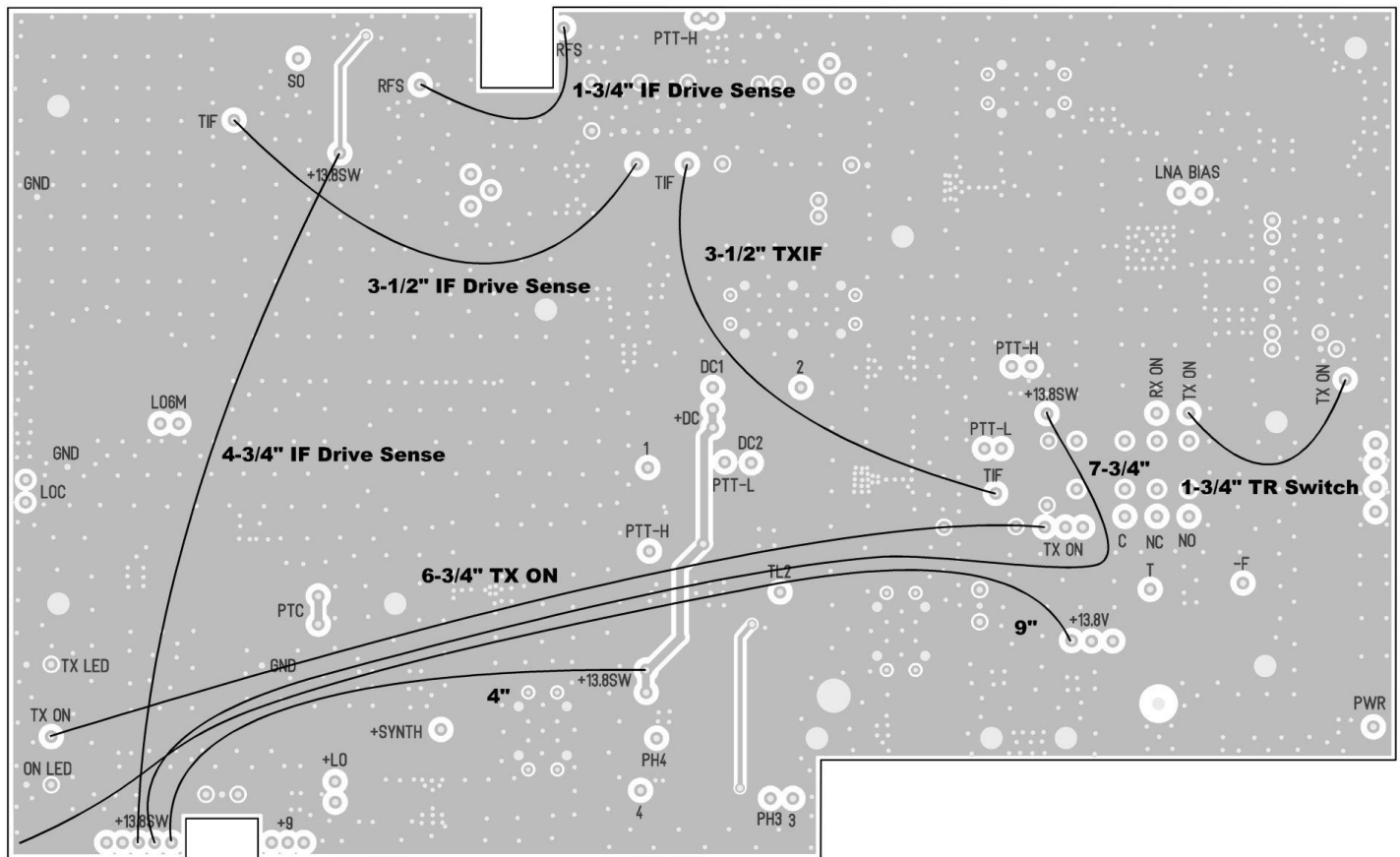

**Bottom Side Board Wiring**

# Q5 SIGNAL VHF/UHF TRANSVERTERS

## A Down East Microwave Product Manufactured by Q5 SIGNAL, LLC

### Surface mounting assembly of components:

The rest of this document assumes that you have the complete kit version. If you have the basic PC board kit, follow along in the instruction manual but skip the instructions that do not pertain to your final assembly.

First, examine the board. It is a basic rectangle with two small notches and one large notch on one corner. If you hold the board so you can read the majority of the screened text left to right, you will find the large notch on the lower left hand side of the board. This is the orientation that the top side component placement document will refer to. In brief, the TX chain and power amplifier is in the lower left, the RX LNA in the upper left, and the IF Drive Sense is on the upper right. The upper center of the board is the IF section and the lower center is the sequencer as shown in **Picture 4**.

What is convenient for assembly is that the circuit board may be mounted to the heatsink before any surface mount work is done. But, if you have a PC board vise that you utilize for board projects, you may want to use it. It is your choice. Since there is no further work to be done on the bottom side of the board, we recommend attaching the board to the heatsink to save a step.

Find the 11 shoulder bushings in the hardware kit and install them in the holes in the heatsink. These act as spacers for the board. Gently “tap” them in. Be sure that they are completely seated. Next locate the position for the NTC as shown on the component placement. It is the largest recessed hole in the heatsink. It must be filled about  $\frac{3}{4}$  of the way with thermal compound before the NTC is installed and is easier to do before the board is attached to the heatsink. Find the tube of thermal compound, use, than save the rest for the Power module mounting later in the kit instructions. **See Picture 5**.

Now find VR5, the 9 VDC regulator. Its leads are mounted through the bottom side of the board. Insert VR5's leads through the board from the bottom side as far as it will go. Then bend it over in the direction as shown in the placement diagram. Do not solder! Align and place the circuit board on the bushings along with VR5 in place. Be sure the one end of the +13.8SW wire that is not attached is out from under the board on the lower right hand side. This wire is connected to the switch during final wiring. Then verify that the board sits flat on the bushings (no wires being pinched) and attach the board with eleven 4-40 x 1/4" screws and one 4-40 x 1/4" screw for VR5. Start all screws first then tighten. Some screws will be removed to ease assembly later during the process and will be specified, but for now, you have a solid mounted circuit board ready for assembly. Solder VR5's leads in place after all screws are seated. **See Pictures 6 & 7**.

It is now recommended to follow the assembly steps listed below. But if you are an experienced builder, you may start on the board anywhere you want placing all of the components listed on the component lists. The assembly steps will cover some options and place importance on some order of assembly but again, nothing is critical and does not need to be assembled in any particular order. If you decide to go about this on your own path, the only precaution is if you desire to test the local oscillator for the correct output level, do not install the Mixer, M1. Leaving the mixer un-installed allows testing of the RF, LO and IF stages independently.

# Q5 SIGNAL VHF/UHF TRANSVERTERS

## A Down East Microwave Product Manufactured by Q5 SIGNAL, LLC

1. Install C39, L11, IC2, and R18. Check the polarity on C39. The band is positive.
2. Install L7, L8, L9, L10, C24, C25, C26, and C27. This is the local oscillator low pass filter. **See Picture 8.** If you wish to test the oscillator level and have a mW power meter, skip the next step. Leaving the mixer un-installed also allows you to test the individual sections of the transverter if you desire. BUT— if you do not have low power measuring capability (less than 100 mw) and accuracy to at least a dB, then proceed to the next step.
3. If you do not wish to test the Oscillator level, install the mixer M1. Line it up on the pads and solder. It is best to tin one pad and hold the mixer in place while heating the tinned pad. Solder the other two by flowing solder and then do the ground pads (3) .It will require some heat to flow the ground connections! **See Picture 9.**
4. Next assemble the IF section of the transverter. Install L22- L27. **See Picture 10.**
5. All of the following components listed in Step 9 except for IC7 can now be installed but their utilization is dependent on the IF configuration you require. An explanation of what certain components do follows along with advice if you choose not to install. For further explanation of the IF section, Refer to the “**TXIF Drive Level Range**” section found in the “**Options Setup**” section.
  - a. CR5 and CR6 are only required for drive levels higher than 1/2W but not required at all if you use separate TX and RX ports. BUT-Having them installed does not inhibit any configuration.
  - b. CR7, CR8, C94 and C99 (C99 is near IC8) are part of the RF sense protection circuit. The circuit is only required for a common IF greater than 1/2W drive configurations but will not inhibit any configuration. Check polarity of C99.
  - c. The 50 Ohm load is required with any drive level above 200 mw regardless of any IF configuration. It will provide attenuation at all drive levels so do not install with lower drive levels. Attach one lead to a #4 ground lug mounted to the load with a 4-40 x3/8”. **See Picture 11**
  - d. C91 should be a 1000pf if the drive level is below 1/2W and 10pF for all drive levels above ½ watt.
  - e. IC7 is the TXIF gain stage and is only installed if the IF drive level is less than 1 mw (0dBm). If your drive level is close to 1mw, install it after the TXRF testing is complete. Depending on test results, it may or may not be required to compensate for lower or higher TX gains in the RF section of the transverter.
6. Complete the assembly of the sequencer by installing Q8, Q10, C103 and C104. Do not mix up Q8 and Q10 and check polarity of C103 and 104! **See Picture 12.**
7. Install TXRF gain stage components IC3, IC4, R21, L31, and C60. **See Picture 13.** Then install C53 and C112 by surface mounting the leads. **See Picture 17.**
8. Install the TX low pass filter. Place and solder C54-C56 first. Then using the pre-wound 3/16” dia. Coils, install L13-L16. The coils have different pitches so follow the pictorial for installation. **See Picture 14.**
9. Install CR11 (lower left hand corner) the power detector diode. Then install Q14 and C115, the fan speed control circuit. **See Picture 14.**



# Q5 SIGNAL VHF/UHF TRANSVERTERS

A Down East Microwave Product Manufactured by Q5 SIGNAL, LLC

10. In the RX section, install L30, C63, C64, L17, and L18. Be sure that C63 and 64 adjust after soldering. **See Picture 15.**
11. Complete the diplexer circuit by installing L19, L20, C70 and C71. **See Picture 16.**
12. Finish the RX section by installing IC6, L21, VR4 and C75. **See Picture 16.**

## **Power Module Installation:**

Place the power module (IC5) on the heatsink in its mounting location. Trim the leads so they do not extend past the solder pads. They should be approximately 3/8"-1/2" long once trimmed. Remove the Module and wipe the mounting surfaces of the heatsink and flange of IC5, verify the surfaces are free of any foreign matter. Apply a thin even coating of the supplied thermal compound to the mounting flange and the heatsink and the bottom of the power module. Place IC5 on the heatsink and "Lap" the thermal compound by moving the module side to side while exerting slight downward pressure. You will feel the resistance build up when lapped. Line up the leads with the traces of the circuit board. (**Note: If supplied hybrid, IC5, is complete with a silver metal shield, it will not require the brass shield. The silver shield hybrid will not need to be soldered to the circuit board as the brass one does.**) Find the brass shield and form to fit as shown. Using one 6-32 screw and flat washer, install it through the shield and the mounting flange, into the heatsink hole nearest the Q11, 3 and PH3 marking on the PC board. Then install the other 6-32 screw with a #6 Lug in the other hole. Tighten evenly into the heat sink. **NOTE:** Make sure IC5 is mechanically sound to the heat sink because improper seating of the hybrid could result in poor grounding and heat transfer causing damage to the power module. Also be sure that the shield does not shift or contact any of the module leads. The shield front should fit between the module and the part of PC board with the bare metal and two board mounting screws. Form the module leads flat to the traces, and then solder all leads of IC5 to the circuit board. Now observe where the shield contacts the bare metal of the PCB. Tack solder along that edge. It will require a lot of heat so take your time. It helps if you loosen the board mounting screws or remove completely. Just don't fill the holes with solder. Re-tighten when complete. **See Picture 17.**

Place IC5 on the heatsink and "Lap" the thermal compound by moving the module side to side while exerting slight downward pressure. You will feel the resistance build up when lapped. Line up the leads with the traces of the circuit board. (**Note: If supplied hybrid, IC5, is complete with a silver metal shield, it will not require the brass shield. The silver shield hybrid will not need to be soldered to the circuit board as the brass one does.**) Find the brass shield and form to fit as shown. Using one 6-32 screw and flat washer, install it through the shield and the mounting flange, into the heatsink hole nearest the Q11, 3 and PH3 marking on the PC board. Then install the other 6-32 screw with a #6 Lug in the other hole. Tighten evenly into the heat sink. **NOTE:** Make sure IC5 is mechanically sound to the heat sink because improper seating of the hybrid could result in poor grounding and heat transfer causing damage to the power module. Also be sure that the shield does not shift or contact any of the module leads. The shield front should fit between the module and the part of PC board with the bare metal and two board mounting screws. Form the module leads flat to the traces, and then solder all leads of IC5 to the circuit board. Now observe where the shield contacts the bare metal of the PCB. Tack solder along that edge. It will require a lot of heat so take your time. It helps if you loosen the board mounting screws or remove completely. Just don't fill the holes with solder. Re-tighten when complete. **See Picture 17.**

Finally, install the NTC in the hole through the board and in the thermal compound in the heatsink. Attach the leads as shown on the components placement after installing sleeving on the leads. The PCB is complete. **See Picture 13 and 17.**

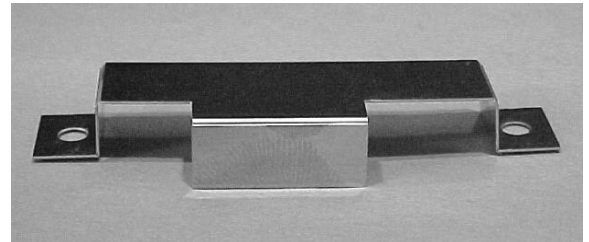
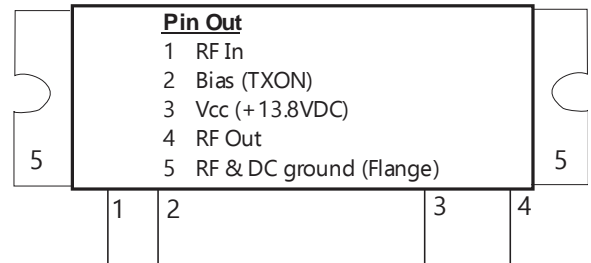

# Q5 SIGNAL VHF/UHF TRANSVERTERS

A Down East Microwave Product Manufactured by Q5 SIGNAL, LLC

## Final Wiring and Assembly

The final wiring and assembly starts with installing the connectors in the rear panel. You may install all of them or only the connectors you will use. All connectors require all supplied hardware. Install all connectors through the labeled side of the panel. Install all with the lock rings on the panel's surface and then the ground lugs (if applicable) between the nut and the lock ring. The DC power connector is positioned so that the "1+" pin is closest to the top of the panel in relationship to the labeling. **See Picture 18** for the correct placement of the solder lugs before wire assembly.

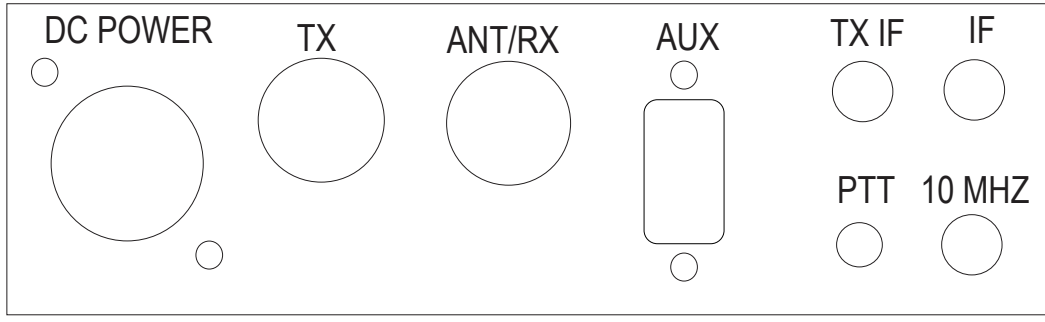

## Rear Panel View

Depending on your requirements, cut, strip, and tin both ends of the coaxes as shown in the next pictorial. Different configurations are explained in the **Options Setup** section at the end of the manual. The lengths of coax are shown below and depend on you specific configuration.

<b>Common IF (the IF BNC Connector)</b>	<b>5-1/2"</b>
<b>10MHz Reference (the 10MHz BNC Connector)</b>	<b>5-1/2"</b>
<b>RFIF (the IF BNC Connector)</b>	<b>5-1/2"</b>
<b>TXIF (the TXIF BNC connector)</b>	<b>6 1/2"</b>
<b>Common RF (the ANT/RX "N" connector)</b>	<b>3"</b>
<b>RXRF (the ANT/RX "N" connector)</b>	<b>3"</b>
<b>TXRF (the TX "N" connector)</b>	<b>3"</b>

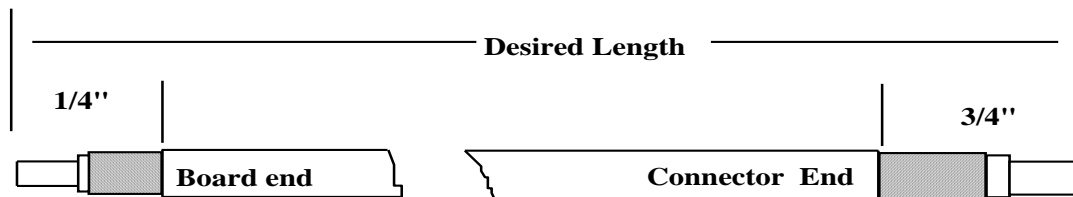

Attach the longer stripped end of the coax to the connector as shown in the next pictorial. Push the end through the hole in the ground lug, solder the center conductor to the center pin, then solder the shield to the ground lug. **See Picture 19.**

# Q5 SIGNAL VHF/UHF TRANSVERTERS

A Down East Microwave Product Manufactured by Q5 SIGNAL, LLC

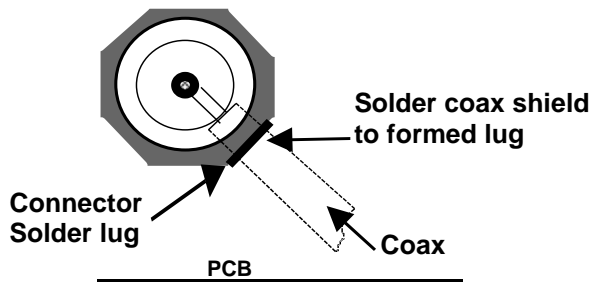

With the pre-cut bundle of colored wire, make wire connections to the AUX and PTT connectors. Follow the wire chart. Strip and tin one end of the wires to 3/16". Tin the connector pins before soldering. All wires are required for sequencer operation and PTT control. **Picture 19.**

<b>AUX Pin 1</b>	<b>11" Orange wire</b>
<b>AUX Pin 2</b>	<b>11" Yellow wire</b>
<b>AUX Pin 3</b>	<b>9" Blue wire</b>
<b>AUX Pin 6, 7, and 8</b>	<b>1-1/2" Black wires (cut from 6" wire)</b>
<b>AUX Pin 9</b>	<b>3" Green wire to PTT Connector (Optional)</b>
<b>PTT Connector</b>	<b>12" White wire---Also install 1000pF disc to ground</b>

The DC power connector should now be wired. Attach the two terminals to the 1 ½" #18 Black wire and the 2 ½" # 18 Orange wire. Strip and tin both ends, ¼". Crimp is fine, solder is best. Push the Orange wire terminal onto Pin +1, black onto Pin -1. **See Picture 20.**

Place one Ty-Wrap on the bundle of wires less the black ground wires and including the PTT White wire as close to the AUX connector as possible. Then attach the rear connector panel to the heat sink using two 4-40 x ¼" screws. Run the bundled AUX and PTT wires between the panel and the circuit board towards the DC power connector bending them around the corner and behind the Power Module. Strip and tin one end of the 15" purple wire and connect it to the PWR via near CR11 on the lower left corner of the board where the AUX wires wrap around the Power Module. Install a second Ty-Wrap at that point. Now, connect the black wire from the Power connector to the ground lug on the IC5 flange. Attach the +DC wire from the power connector to the bare metal marked 13.8V on pin 3 of the power Module. Then Ty-Wrap the bundle to the DC ground wire connection on the side of the power module. **See Picture 13.**

Finish the panel wiring by connecting the short Black wires from the AUX connector (Pins 6, 7, 8) to ground. Insert the three wires into any of the "GND" via-holes in the circuit board near L16. The via-holes are plated through so use a lot of heat to flow the solder. **See Picture 14.** Then begin to connect all of the coaxes to the circuit boards as you have planned for your configuration. If you are unsure of their connections, you may refer to the "**Common or Split IF Option**" and the "**Common or Split RF connections**" section found in the "**Options Setup**" section of this

# Q5 SIGNAL VHF/UHF TRANSVERTERS

A Down East Microwave Product Manufactured by Q5 SIGNAL, LLC

manual. There should be a minimum of two and a maximum of five coaxes. Be sure that the shields are soldered to the board well. It is Teflon coax so do not be afraid to heat the connection! **See Picture 20.** Then connect the other AUX connector wires to the sequencer section. Pin 1 to Via 1 on the board, then Pin 2 to 2, Pin 3 to 3. This will provide Pin 1 with voltage on RX, Pin 2 with Voltage on TX and Pin 3 will be a connection to Ground on TX. Trim, strip and tin the wires before connecting. If you desire any other sequenced signal, consult the Sequencer schematic and its matrix for alternative connections. **See Picture 12.**

The PTT wire may be connected to the PTT-H or L in the sequencer if you plan to use the sequencer or connected directly to the transverter's PTT-H or L near the K1 relay. If you are using the sequencer, install the 6" White/Org wire from the "4" via in the sequencer to the PTT-L via near CR9. With the left over green wire, strip and tin two 1" green wires. Connect one from +DC to DC1. And another from +DC to DC2 in the sequencer. Strip and tin a 3" wire and install one end in the +13.8SW via near VR5. **Pictures 12 and 21.**

Begin to Pre-wire the U-channel front panel by assembling the enclosed RFPM kit. This is the bar graph power meter. The board and circuit has been modified and the kit only contains the components (7) required for a positive voltage detection. When completed, install a 2" black wire (GND Connection) and a 6" green wire (+V). Strip and tin both ends of both wires. You may test the RFPM separately before installing. It requires 12VDC (+ and -) on the two wires and a variable voltage from 0 to 5 VDC on the DET connection. You should be able to vary the voltage and move the Bar Graph display up and down. The Pot will adjust its sensitivity. When complete, find two ¼" threaded hex stand-offs and two 4-40 nuts. Pass the threaded end of the stand-offs through the two mounting holes on the RFPM board so that the threads are on the component side of the board not the display side. Then hand-tighten the nuts. Install the RFPM in the front panel with two 4-40 Black screws. Center the display and tighten the nuts and the screws. **See Picture 21.** Then cut, strip and tin the wires on the two LEDs to 2". Install the Green (ON) LED and the Red (XMIT). Install the switch in the front panel then install the front panel to the heatsink with four 4-40 X ¼" screws and four 4-40 black screws to the rear panel. Start all screws first, and then tighten. It may be necessary to loosen the rear panel a bit to get all screws started. Be sure not to trap any wires under the panel. **See Picture 25.**

The front panel wiring starts by connecting the black wire of the power meter to any via hole in the circuit board below. The +DC wire connects to the 13.8SW via near VR5. The 15" purple wire from the PWR via on the board connects to the DET via on the RFPM. Strip, tin and connect. The LED's are connected next. The Red connects to the TX via and the Green to the ON LED via. There are associated ground vias near each connection. Strip, tin, and solder. Now, attach the wire coming out from under the board to the center pole of the switch. Strip, tin and solder. Then connect the wire from the +13.8SW connection to the top lug on the switch. **See Picture 21.**

Installation of the Fan Option is recommended. Turn the transverter over so the Heat sink is up. Notice that all of the holes are not filled. There are four 6-32 tapped holes and a large thru-hole. The thru-hole is for the wire of the fan. Feed the wire through the hole and place the fan on the heatsink, label down so that it blows air into the fins. Be sure that the wire is not trapped

# Q5 SIGNAL VHF/UHF TRANSVERTERS

## A Down East Microwave Product Manufactured by Q5 SIGNAL, LLC

between the fan and a rib of the heat sink. There is a notch in the fan that the wire passes through. Place the fan grill on it and bolt down the assembly with four 6-32 x 1-3/4" bolts. Make them snug but do not over tighten. **See Picture 24.** Turn the assembly back over and dress the wires by Ty-Wrapping them to the sequencer wires near the step "3" connection. Then follow the PTT and DC power wire across the Module. Cut, trim, and tin the Red fan wire and attach it to the +13.8V pad with the DC power wire. Continue to route the Black fan wire to the -F pad. Cut, trim, and solder. Install a Fifth Ty-wrap to bundle the PTT, +DC and fan wires if desired. **Picture 13.**

Install the blue "LOCK" LED. It mounts in its holding clip in the front panel "LOCK" hole. Solder the long LED lead to one of the "LOC" vias. The short lead gets soldered to the nearest ground via or pad. Cut a 3" length of coax. Prep one end for 1/4" and the other end for 3/4". Solder the braid of the 3/4" end to the ground side of C42. And the center gets soldered to either end of C34. **See Picture 21.**

Remove two PCB mounting screws - one near the mixer M1 and another screw near IC9. Using the two 1" spacers and two 4-40 x 1-1/4" screws, mount the synthesizer board directly above the sequencer circuit. Solder the free end of the 3" coax to the synthesizer's "RF OUT". Solder the free end of the 10MHz coax to the synthesizer's "REF IN". Connect a 4" wire from the "LOC" pad on the transverter board to the "LOCK" via on the synthesizer. And connect a 3" wire from the +9V via on the transverter board to the +V via on the synthesizer. **See Picture 23.**

Last step before testing is to assemble the DC power cable. Basic instructions are on the connector's package. Be sure to observe proper polarity.

**Test Section:** Before applying DC power to the complete transverter, verify main DC wiring and have a proper fuse installed in the DC power cable or supply. Install some sort of 50 Ohm load on the ANT, TXRF, or RXRF ports. Verify that the PTT port is not shorted. If all looks good, apply DC power and switch on. The Green LED should light and the TX LED (RED) will remain off. The blue "LOCK" LED will also be off unless a 10MHz reference is connected.

Start by verifying voltages on the board. All voltages should coincide with the DC input voltage from the power supply unless it is on the output of a regulator. There is a voltage matrix at the end of the test section that may be used for checking and troubleshooting. You could verify every point or in general, check VR4 (5 VDC) and VR5 (9 VDC). Verify the +13.8SW voltages and the +DC in the sequencer. Check Pin one in the sequencer for +12VDC or greater. The bias resistor side of IC2 and IC6 should be around +5 VDC +/- . The drain of Q6 (junction of L18 and C69) should be around 3.8 VDC. Verify -F to be somewhere between 6 and 13 VDC depending if the fan is running or not. If voltages do not fall in line, check wiring or assembly. When complete, shut power switch off. All other preliminary tests are complete and TX tests and will be covered in the TX test section.

**Oscillator Testing without mixer installed:** Start by connecting a test coax to the LO input pad of the mixer M1 and ground. This will allow the measurement of the level injected into the mixer. You may also measure the frequency of the oscillator with this connection. Connect the coax to a power meter set to measure 100 mW. Switch the DC power on. Verify the output power level on

# Q5 SIGNAL VHF/UHF TRANSVERTERS

## A Down East Microwave Product Manufactured by Q5 SIGNAL, LLC

the power meter to be between +15 and +19 dBm. If low, check IC2 for function, missing components in the LO Low Pass Filter, or wire connections. Refer to the voltage check sheet at the end of the test document if needed. If the level is OK and you have a spectrum analyzer, you may verify the 2<sup>nd</sup> harmonic content. It should be a minimum of -40 dBC (40 dB below the fundamental). If not verify the Low pass filter (the components between C24 and C28). Now, if all tests are ok, you may install the mixer or not and proceed to the General Oscillator testing section. Leaving the mixer un-installed when the Oscillator testing is complete will allow other testing in the TX, RX and IF stages. Installing the mixer when testing is complete will complete the transverter.

**Receiver Testing With the mixer installed:** Depending on your configuration, the RXRF input port and RXIF output ports will vary. It is assumed that the voltage checks were made and determined to be in spec before the Receive RF test is made. Use whatever means to generate a signal into the RF port (on air signal, signal generator -30dBm or less, or a Noise figure meter) and use whatever 28 MHz receiving device you desire to peak C63 and C64 for maximum gain. **See picture 22.** If you use a noise figure meter, you may find that the best noise figure is not the maximum gain but if you only have gain measurement capabilities, the noise figure may not be optimized but will be close. Be sure to rotate R39 (RXIF Gain adjustment) to verify function. There should not be a need for adjusting the filters and is recommended not to unless you have test equipment that a filter response can be verified on. If 17dB of conversion gain (15 minimum) cannot be achieved, start by verifying voltages on Q6 and IC6 then check kit installed components. Use whatever means to signal trace from input to output to find the problem. Be sure of the RXRF and RXIF configuration and check for shorts on the coaxes and solder shorts on the boards.

**Receiver testing without the mixer installed:** There should be a minimum of 23 dB of conversion gain depending on the tolerance of the filters and the active components. If you have the ability to check the pass band or then desire to optimize it, do so only with extreme care. The filters have been matched to 50 ohm in/out and a specified pass band response to match the weak signal portion of the band. There should not be a reason to “Re-adjust” but—you can if desired. Just remember that F2, the three pole filter is also a TX filter and is responsible for the rejection of the local oscillator signal that bleeds through the mixer and all products of the LO-IF combination. If testing the RXIF section of the transverter, there should be no more than 3 dB of loss at 28 MHz and will roll off fast above 32 MHz. The low pass filter/ diplexer in the circuit are there to keep all signals above 32 MHz out of your receiver that may be produced within the mixer.

**Transmit Testing:** Depending on your configuration, be sure to have some sort of 50 Ohm load and or RF power meter connected to the designated TX port of the transverter. Preliminary TX testing is done without IF drive being applied. Start by manually enabling the PTT signal (High or Low depending on your configuration). This in turn will enable the TX section and disable the RX section of the transverter through the sequencer or directly depending on your configuration. All relays installed will actuate and the Hybrid power module will draw quiescent current of up to 6 amps. The other TX driver stages and the TXIF amp if utilized will also be biased.

**IMPORTANT NOTE:** Do not assume that if the output power of the transverter is low that it is because you do not have enough **IF drive**. Please consult Q5 Signal if you have problems

# Q5 SIGNAL VHF/UHF TRANSVERTERS

## A Down East Microwave Product Manufactured by Q5 SIGNAL, LLC

obtaining full output power with your specified drive level during the test procedure after you have exhausted all possibilities discussed in the procedure.

**Testing with the mixer installed**, enable the PTT circuit (without IF Drive) and verify that there is no relay chatter and the total transverter current drain is less than 6 amps. In this state, verify the TX voltages on the matrix. You may notice the fan speed increasing as the transverters TX time is extended. When finished checking all of the TX voltages, un-key the transverter. If there is a problem, find it by checking the wiring first then the kit assembled components. If all OK, rotate R36 fully counter-clockwise (maximum attenuation) and then connect the TXIF drive source. Manually enable the PTT and apply the minimum amount of drive that your transceiver can produce. Verify any output on the power meter. Slowly increase the drive level of the transceiver to the **maximum drive you have configured the transverter for** while observing the power meter. Then adjust the TXIF gain control (R36) to obtain 20-25 watts of output power.

If you cannot achieve any output power, verify opens or shorts starting with the TX output connector then back through the TX section. Look for opens in the Low pass filter L13-L16. If the TR relay is in your configuration, verify its function. You may disable the bias to the RF power module by removing R22. The relay and Low pass filter can then be checked with an Ohm meter. Recheck the TX voltages in the TX chain. Then proceed through the IF section looking for opens or shorts and the function of the TX IF relay if in use. Retest with low drive power first.

If the correct amount of power cannot be achieved (low power), the problem can only be a few things. First check the output low pass filter, L13-L16, C54-56. Verify the windings and you may try to spread or compress the turns for an additional output power. The filter is there to eliminate the 2<sup>nd</sup> harmonic up so—no matter how you adjust the “L’s” it will not affect the attenuation of the 2<sup>nd</sup> harmonic but may increase or decrease the insertion loss at the operating frequency. Also verify that the filter components are not heating. (Touch them with RF off) if warm, something is installed incorrectly.

Next suspect the TXIF components. Verify that the Pin diodes CR3 and CR4 are functioning. If the RX gain is OK, the filter diplexer should be OK but you can verify with an ohm meter anyway. Next understand that even if you have configured the transverter correctly, the operating range may be on the edge. Your drive level from your transceiver may not be what was specified. If you have measured and verified it, then depending on your configuration, you may vary the value of C91 if you are using the load. If you are using a low drive level (around 0 dBm) you may need to install the TXIF gain stage. Do not install it if you use more than 5 mW of drive.

**Testing the TX section without the mixer** is easy. Apply a low level of around -10dBm to the input of F2. Enable the PTT and measure power. Increase the drive to achieve the correct amount of output power. Adjust the output Low pass filter for maximum power. F3 may be optimized but it should not need it. If F2 is tweaked, it will affect the RX section. You may now also check the TXIF section of the transverter. Verify the TXIF gain control and the pin diode switching network. The insertion loss of the TXIF section including the filter/diplexer should be less

# Q5 SIGNAL VHF/UHF TRANSVERTERS

## A Down East Microwave Product Manufactured by Q5 SIGNAL, LLC

than 3 dB @ 28 MHz. If all tests OK, you may now install the mixer and either test with your transceiver or your signal generator if desired to verify the complete assembly.

**Bar Graph RF Power Meter:** While the power meter is connected, the RF bar graph meter calibration can be done. During key down, obtain a 25 watt output level and adjust VR1 on the bar graph to show 9 bars lit. Then vary the power or use SSB to generate RF and follow your speech pattern on the bar graph. Remember that the Bar Graph display is relative and its function may be affected by high VSWR.

**IF Drive Sense Circuit:** The IF drive sense circuit is a protection circuit only. It should only be utilized with IF drive powers above 200 mW and is only used with a common IF configuration. It will operate at drive levels down to 10 mW. To preliminary test it, you can apply a low level voltage to any RFS via (1-2 volts) and the TIF signal near Q26 should go high. This voltage energizes the K3 relay. The purpose of C94, CR7 and CR8 is to sample and convert the 28 MHz RF energy to DC voltage. To test, lower your IF drive down to the lowest level possible. Then key your transceiver and apply drive. The TIF signal should go high. If not verify the CR7 and CR8 diodes and the RFS signal with an ohm meter. After the transverter is enabled on transmit either through the sequencer or directly by your transceiver's PTT, the K3 relay and the rest of the TXIF circuit will be energized by the transverter's TXON voltage through the CR21 isolation diode.

**Fan Speed Controller:** The fan speed controller should operate on its own speeding the fan up as the transverter heats. You can check the voltage at -F as the transverter is heating. This is the negative lead to the fan and as the transverter increases in temperature, this voltage will move closer to Zero or ground. If you find that the fan is running too early, you can lower the value of R77 from 1K to 910 ohms or even 820 ohms. This also means it will start later in the temp cycle which may affect the frequency stability but its adjustment may increase or decrease the delta in frequency change over temperature.

**Sequencer:** Testing of the sequencer is simple. Just verify the steps are what it is connected to in both TX and RX modes. If wired as recommended, 1 is positive voltage in RX, open in TX. 2 is open in RX, positive voltage in TX. 3 is open in RX and Ground in TX. 4 is what enables the transverter. It is open in RX and Ground in TX. This is reflected on the matrix on the sequencer schematic. If you wire it differently, use that matrix to note your changes.

For mast mount LNA operation with the basic transverter or with an external high power amplifier, all switching tests should be done without RF applied. Verify that the switching is completed in your desired sequence and gradually add in external components as verified. The last test should be with the transverter's RF applied. All testing can be done without coaxial cables connected. Connect the transverter's IF or TXIF cable last.



# Q5 SIGNAL VHF/UHF TRANSVERTERS

## A Down East Microwave Product Manufactured by Q5 SIGNAL, LLC

- Step 1 +12VDC on RX for a preamp @ 500 mA maximum
- Step 2 +12VDC on TX for a TR relay (around the preamp) @ 500 mA maximum
- Step 3 Ground on TX to key a power amplifier. Sinks 100 mA maximum
- Step 4 Ground on TX to key Transverter. Sinks 100 mA maximum

### Optional Sequencer Connections:

Step 1 and 2. They can be connected to switch higher DC voltages. The DC voltage is applied to the DC1 and DC2 connections on the board (30VDC, 100 ma. maximum). Higher current at higher voltage, such as with multiple TR relays, may be switched on step 2 if the circuit is re-wired. The yellow wire in Via #2 near Q10 is removed and replaced with a connection to ground. The yellow wire is then placed in the DC2 connection. This will now pull any relay up to 500 ma to ground.

Step 2. TL2 is a secondary connection to the second step. It is a “LOW” on transmit. It can be used to drive a relay or key an amplifier but an external isolation device should be utilized. It will sink 100 mA maximum

Step 3 and Step 4. They have secondary outputs that are both “High” on transmit. They are labeled PH3 and PH4. These should be isolated from devices that require high currents and are intended to drive low current devices or Pass transistors or FETs. They will source 5mA.

The transverter’s sequencer may be by-passed to eliminate switching time delays. The external PTT input of the transverter may be connected directly to the transverter’s PTT input (see component placement document) near C100 or C102 bypassing the sequencer.

With all circuitry now checked, close up the transverter. The TXIF and RXIF adjustments are accessible through the bottom cover. The frequency adjustment is not and it is best not to drill an extra hole for it. This will be explained in the **General Operation, Oscillator** section.

### Test Point Matrix

Device/mode	Input	Output	Emitter/Source	Base/Gate	Collector/Drain
IC2 RX	1.0-2.0VDC	4.5-5.5VDC	NA	NA	NA
IC6 RX	1.0-2.0VDC	4.5-5.5VDC	NA	NA	NA
Q6 RX	NA	NA	0.35-0.65VDC	0VDC	3.4-3.9VDC
SEQ Pin1 RX	NA	13-14VDC	NA	NA	NA
IC5 pin2 TX	4.2-4.8VDC	NA	NA	NA	NA
IC3 TX	2.2-2.8VDC	4.5-5.0VDC	NA	NA	NA
IC4 TX	1.5-2.0VDC	5.0-6.0VDC	NA	NA	NA
IC7 TX	2.2-2.8VDC	4.5-5.0VDC	NA	NA	NA
SEQ Pin2 TX	NA	13-14VDC	NA	NA	NA
TIF TX	NA	12-14VDC	NA	NA	NA

# Q5 SIGNAL VHF/UHF TRANSVERTERS

## A Down East Microwave Product Manufactured by Q5 SIGNAL, LLC

### Installation and Operation

**Theory of Operation:** The basic principle of a VHF/UHF transverter is to convert a chosen band of operation to the 28 MHz. band of a HF transceiver. Following the recommendations of the HF transceiver's operation manual for transverter use is the most important aspect of correct transverter operation. If configured correctly, the transverter will convert both transmit and receive signals to a new band of operation and seem "invisible" to your HF transceiver's operation. In simple terms, the transverter will not improve the performance of your HF transceiver but will not cause any degradation of performance in any way.

### **Interfacing and Operation:**

**MOST IMPORTANT:** When interfacing your transverter, it is recommended that all usable features of the transverter are tested and proven before integrating the transverter into your system. This means verifying the transverter functions correctly with the transceiver before interfacing to High Power amplifiers, mast-mount LNA's, and external TR relays. During the initial setup of the transverter, test all switching functions before applying RF. Implement one accessory at a time confirming the switching function, then RF function. Start with low RF drive levels and gradually increase to the final desired level.

It is assumed that since you have assembled this transverter to your specifications, interfacing will be easy. But—we will offer some tips that may have been over looked. Start the interfacing with good quality 50 ohm cables for the IF (28 MHz.) connections. These connections may be low level or at the 25 watt level depending on your configuration and good quality BNC type connectors with adapters to your transceiver are fine! The shielding quality is important to prevent other 28 MHz signals from "Creeping" into your transceiver.

All transverters will require a PTT (to ground or positive voltage on TX) to enable the transmit mode of the transverter. The PTT input to the transverter is a RCA connector. This cable does not need to be shielded, but extra protection in a QRO station is a good idea! Most transceivers have RCA connectors for PTT outputs but others have various connections. Be sure to have whatever cable that is required ready to go.

The DC power cable should be connected to the desired power supply. If you require a longer DC power lead, consider moving up one gauge to eliminate a voltage drop problem. Plan on 6 amp current drain and please fuse the line.

The AUX connector will contain all sequencer connections and any other special requirements or any other inputs or outputs you desire. The matching connector to the AUX connector is supplied and should be wired before final interfacing.

If using a mast mount LNA, the IP3 performance of the transverter will be limited by the LNA and total system IP3 performance will be degraded. The amount of degradation will depend on the performance characteristics of the LNA. Yes, the total system gain can be controlled by the RXIF gain control but the dynamic range of the transverter will be reduced by the amount of gain of the LNA at the minimum. Such a system should have the capability of switching the mast mount LNA out of the system. Use of an "In the Shack" LNA in front of the transverter is total nonsense! If you believe your system is lacking gain and the transverter is in spec, find the problem in your

# Q5 SIGNAL VHF/UHF TRANSVERTERS

## A Down East Microwave Product Manufactured by Q5 SIGNAL, LLC

transceiver or antenna system. If you must, you may install an IF amplifier on 28 MHz so not to degrade the transverter's "RF" performance.

Another suggestion is if you are to use a mast mount preamplifier, you may consider bypassing the transverter's LNA. It requires removing R31 and R26 from the circuit. Then move the RXRF connector cable to the C68 pad. This will utilize the diplexer and first filter in the receive chain and disable all DC power to the Q6 FET.

The national calling frequencies will be on 222.100 or 28.100 MHz on your IF transceiver. Use of the transverter outside of the Weak Signal portion of the band is possible but slightly degraded performance may be expected. The transverter is designed specifically for the weak signal portion of the band.

Setting your final output power of the transverter is recommended to be done in the CW mode. BUT—verify that if you change modes of your transceiver, the drive levels do not change or overdrive may occur in the SSB mode causing undesirable effects on the band!

The bar graph display is a relative power meter and is driven by the directional coupler and RF detector circuit found in the Low pass filter section of the board (CR11, R76,R75,C108) RF is detected and converted to DC voltage and conducted to the Bar graph display on the front panel. If you find that you operate the transverter at any other level than what it is calibrated to you may change it by adjusting VR1 on the display board. Also remember being that is a reference meter, if your VSWR should increase, it may or may not show an increase or decrease on the bar graph display.

**General Operation:** General operation of the transverter, if everything is adjusted correctly, should be transparent to the transceiver and the user. Except for the frequency read out, (if your transceiver doesn't allow its display to be adjusted for transverter operation) it will be like operating on 10 Meters. All of the functions of the transceiver (filtering, DSP, split band operation, dual VFO) will be transposed to the frequency band of the transverter.

Some cautions should be taken when operating CW or VOX. Operating the transverter in a "Full Break-in" mode is not recommended. Because of the mechanical relays in the transverter, there will be too much delay to operate "Full Break-in" effectively. AND—the relays would be abused if "Full break-in" is enabled. It is best to operate in "semi break-in" and adjust the delay of the PTT on your transceiver to match your comfortable CW operating speed in a way that the delay will hold the PTT until your transmission is complete. If you have implemented the sequencer, its delay will need to be longer to allow all components within the system (Power amplifier, LNA, relays) to complete their transition if utilized. If just the transverter is to be used alone, the transceiver PTT signal may be connected directly to the transverter's PTT input bypassing the sequencer. This will shorten up the delay but will still not allow "full break-in" without relay chatter.

# Q5 SIGNAL VHF/UHF TRANSVERTERS

## A Down East Microwave Product Manufactured by Q5 SIGNAL, LLC

### Options Setup:

**Common or Split IF Option:** The IF configuration may be changed at any time according to the type of transceiver you are utilizing. Refer to the Component placement or schematic for clarification. The component designators are also screened on the circuit board.

K3 is the common IF relay. To split the IF lines into separate RXIF and TXIF, remove the IF coax from its position on the board (junction of C93 and C94) and re-attach the center conductor between C95 and K3. You may need to scrape a little solder resist from the pad before soldering. The shield may be now soldered where it was on the ground pad marked COM. The TXIF cable can be prepped and soldered to the pad between K3 and C92. The shield can be soldered to the ground pad labeled TXIF. Install a BNC connector in the rear panel (TXIF) and attach the TXIF coax. Reverse the procedure if you want to change to or back to Common IF.

Please note that if you have a separate IF configuration, the IF drive sense option will no longer function. It is not necessary with the split IF. It is to protect the RX circuit and Mixer from being damaged with the TXIF drive power.

**TXIF Drive Level Range:** The TXIF drive level range can be changed at anytime to conform to your transceiver type. Basically, there are three configurations. For high IF drive levels, (250 mW-25 watts) the 50 Ohm load will be installed with a low value capacitor in the C91 position (10 pF or less for 25 watts). Mid level drives between 1mW and 250 mW will not have the load installed and will have a 1000 pF capacitor installed for C91. For the low drive levels (-20dBm to 0dBm or 1mW) IC7 will be installed. If you desire to change the drive level for whatever reason, just duplicate the info above. To install IC7, remove the bypass jumper before installing. Install a MAR-6 as shown on the component placement. Other MMIC's may be used if your desire but the bias resistor R34 may need to be changed. Adjust R36 to obtain desired level in all cases. The important thing to understand is the IF drive range is wide and can accommodate different drive levels between the specified ranges.

**Common or Split RF connections:** The transverter utilizes K2 as the common RF relay. It is mounted on the circuit board. The common port is marked ANT on the board. The split RF connections are labeled TX and RX on the board at each end of the relay. There is no need to remove the relay for the split connections. Simply remove C122 and C62 and solder coax directly to the marked pads. So--, depending on which way you are going, install/uninstall cables and connectors as required. Remember, if you have separate ports, they may be combined with an external coaxial relay to provide versatility.

# Q5 SIGNAL VHF/UHF TRANSVERTERS

A Down East Microwave Product Manufactured by Q5 SIGNAL, LLC

## Power Meter

BAR1 BAR GRAPH DISPLAY

IC1 LM3914

C1 1000 DISC CAP

R1 2.7K 1/4W RESISTOR

C2 100 $\mu$ F ELECTROLYTIC CAP

VR1 10K POTENTIOMETER

C3 0.1 $\mu$ F DISC CAP

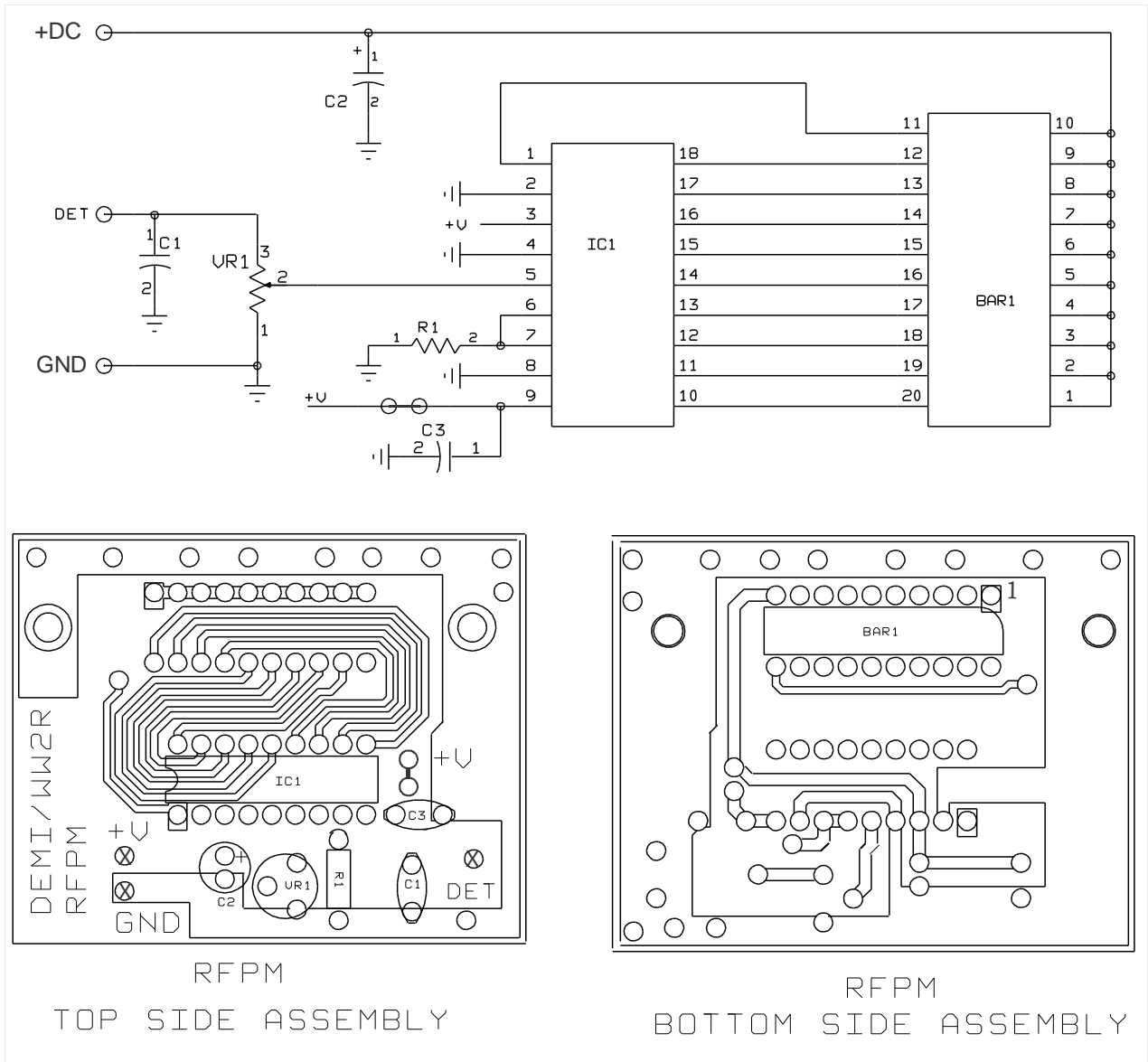

# Q5 SIGNAL VHF/UHF TRANSVERTERS

A Down East Microwave Product Manufactured by Q5 SIGNAL, LLC

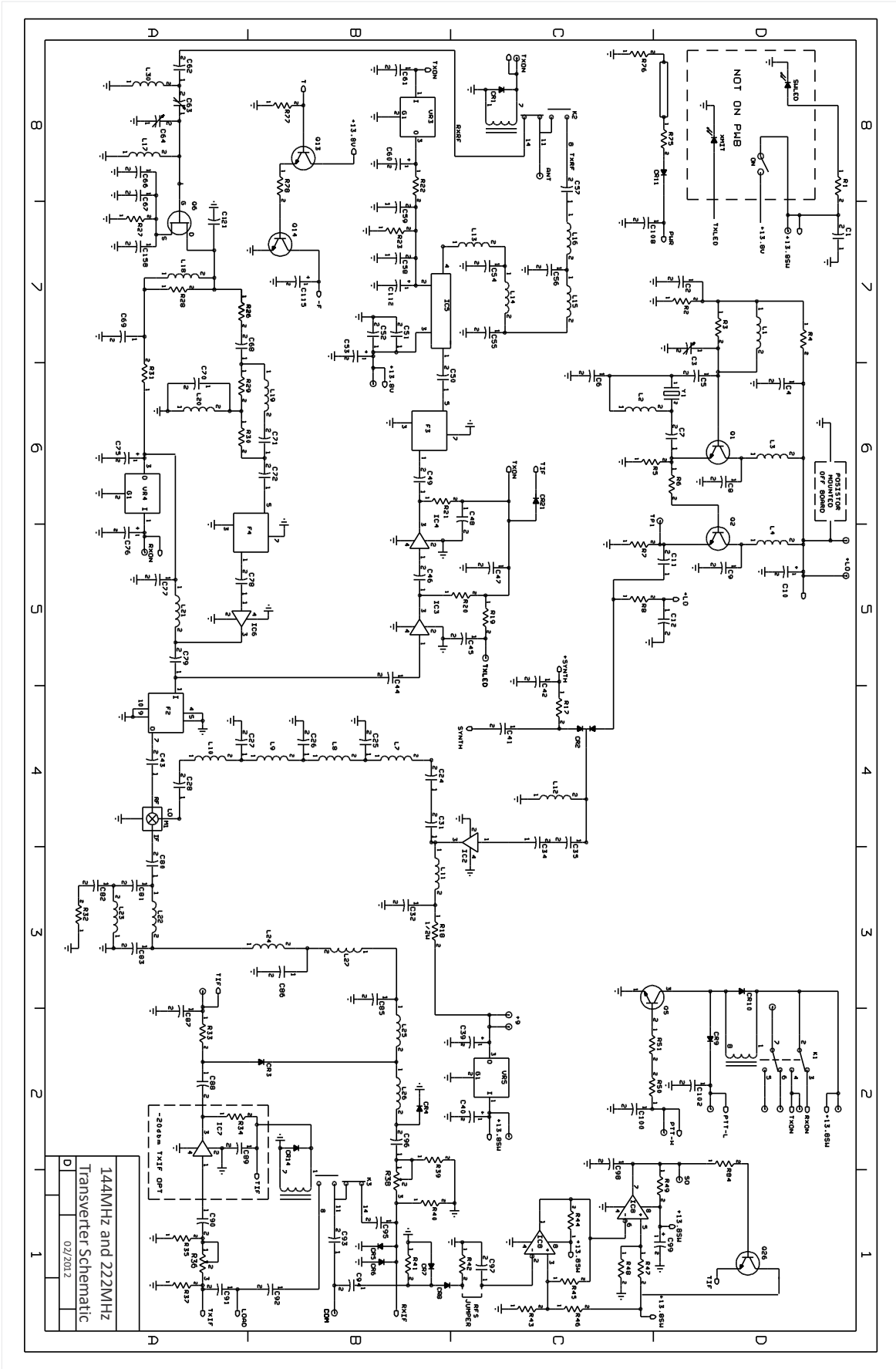

# Q5 SIGNAL VHF/UHF TRANSVERTERS

A Down East Microwave Product Manufactured by Q5 SIGNAL, LLC

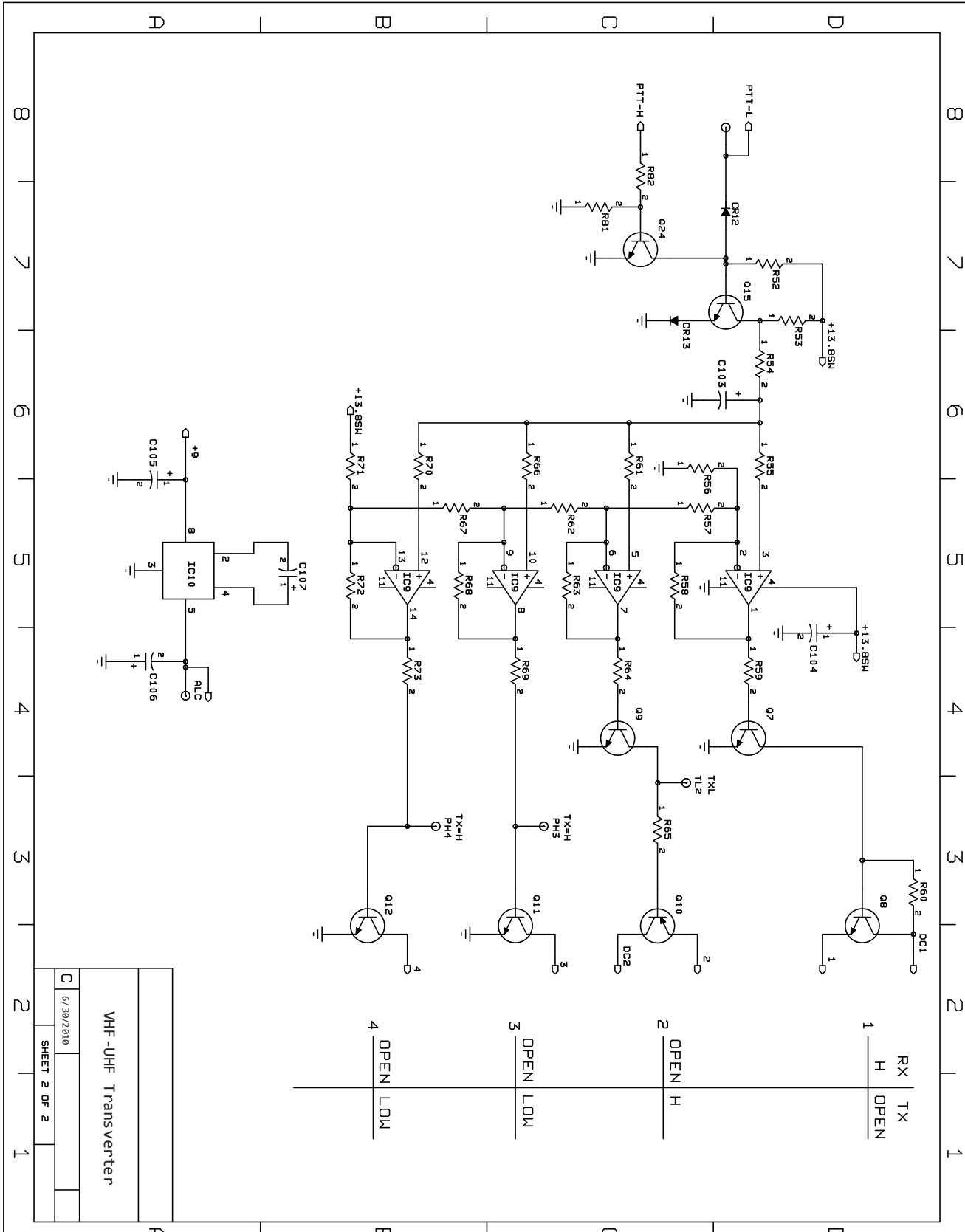

VHF -UHF Transverter	
6/30/2010	
SHEET 2 OF 2	

# Q5 SIGNAL VHF/UHF TRANSVERTERS

A Down East Microwave Product Manufactured by Q5 SIGNAL, LLC

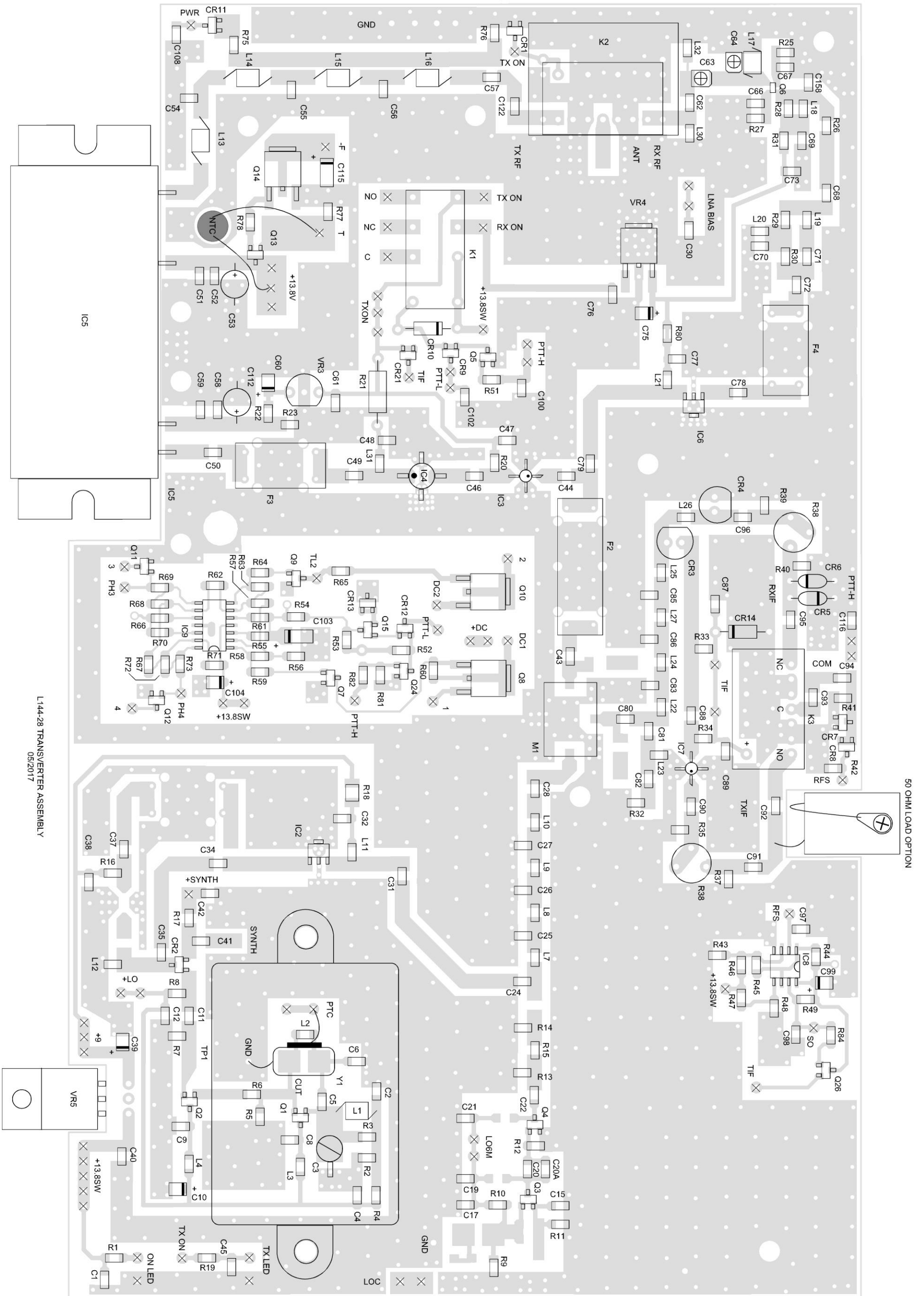

L144-28 TRANSVERTER ASSEMBLY  
05/2017



# Q5 SIGNAL VHF/UHF TRANSVERTERS

A Down East Microwave Product Manufactured by Q5 SIGNAL, LLC

## 1. Proper Filter soldering on bottom side.

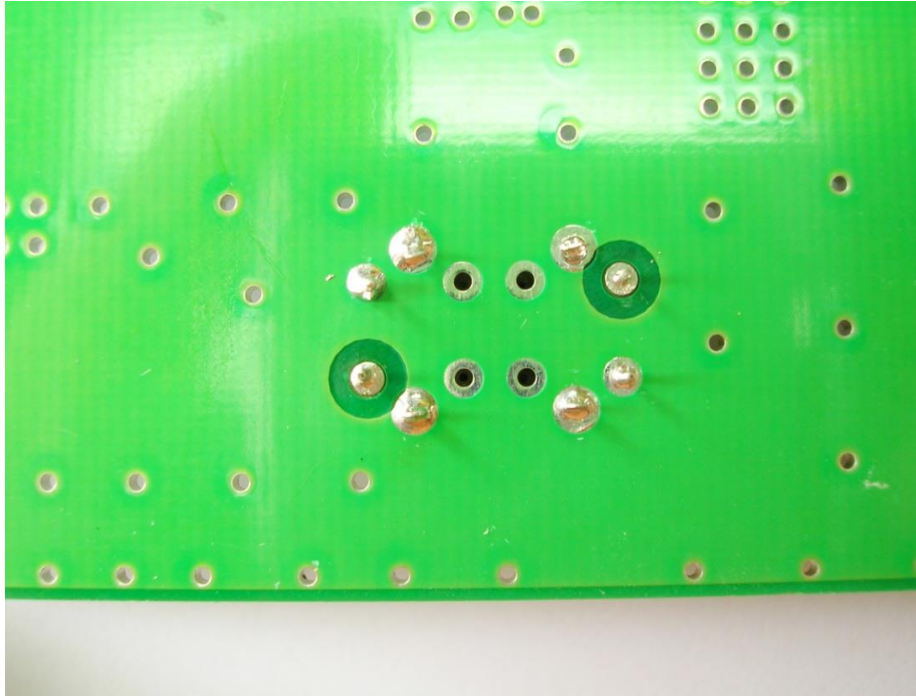

## 2. Some bottom side soldered, topside components.



# Q5 SIGNAL VHF/UHF TRANSVERTERS

A Down East Microwave Product Manufactured by Q5 SIGNAL, LLC

### 3. Correct wire soldering with solder mask.

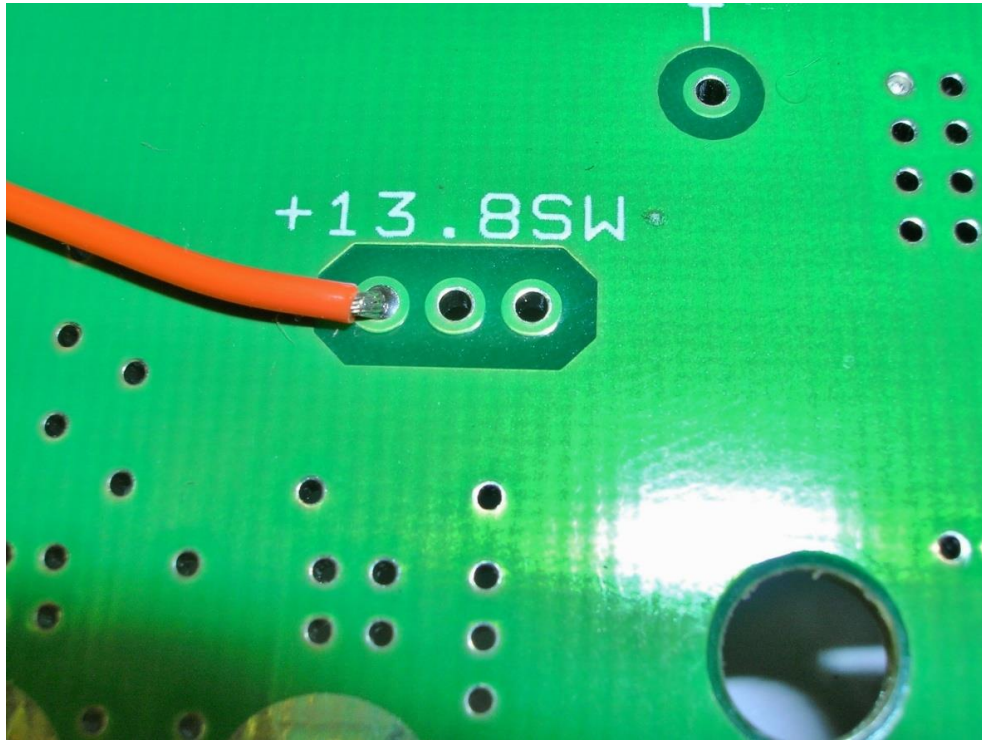

### 4. Topside board layout and labeled sections.

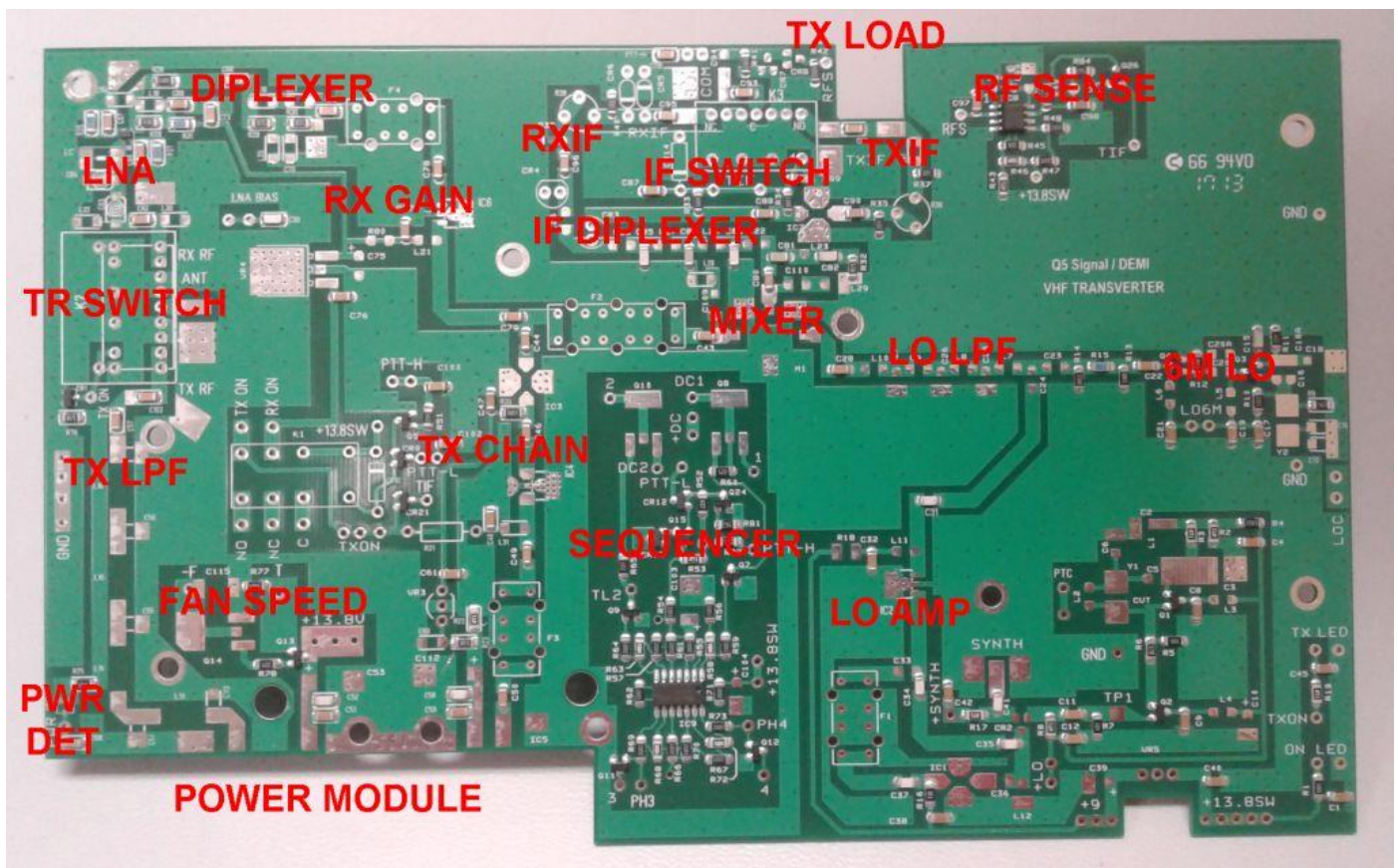

# Q5 SIGNAL VHF/UHF TRANSVERTERS

A Down East Microwave Product Manufactured by Q5 SIGNAL, LLC

## 5. Shoulder bushings and NTC hole with thermal compound.

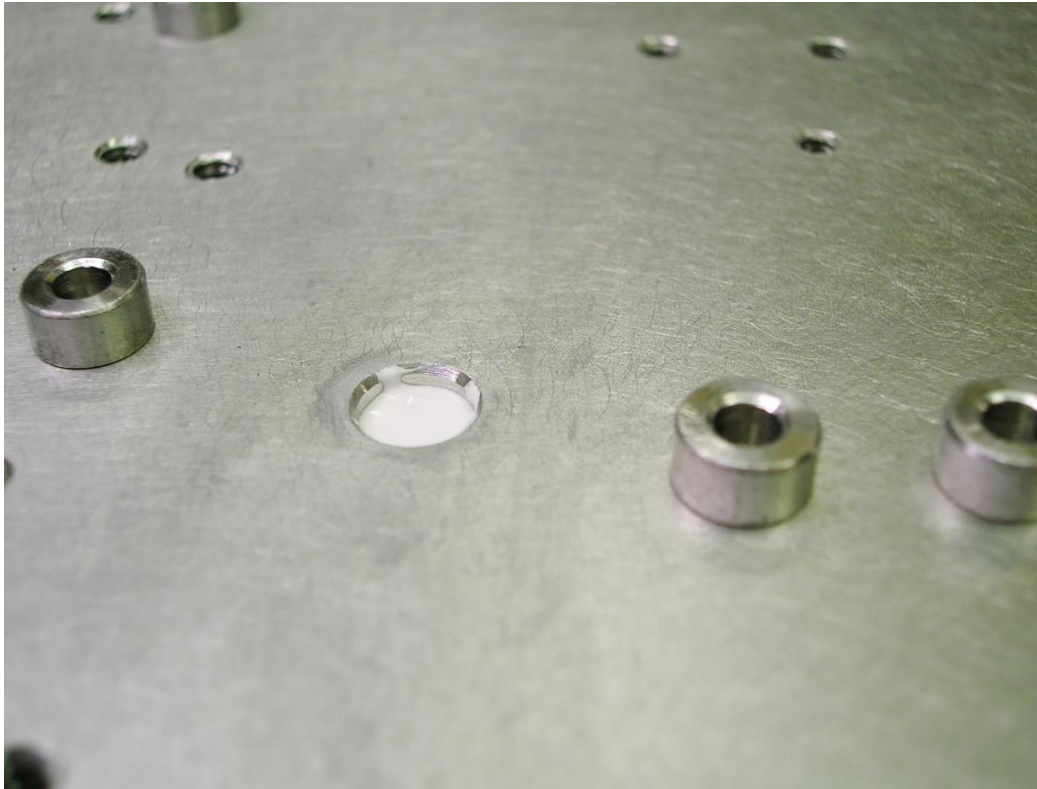

## 6. VR5 and PCB mount.

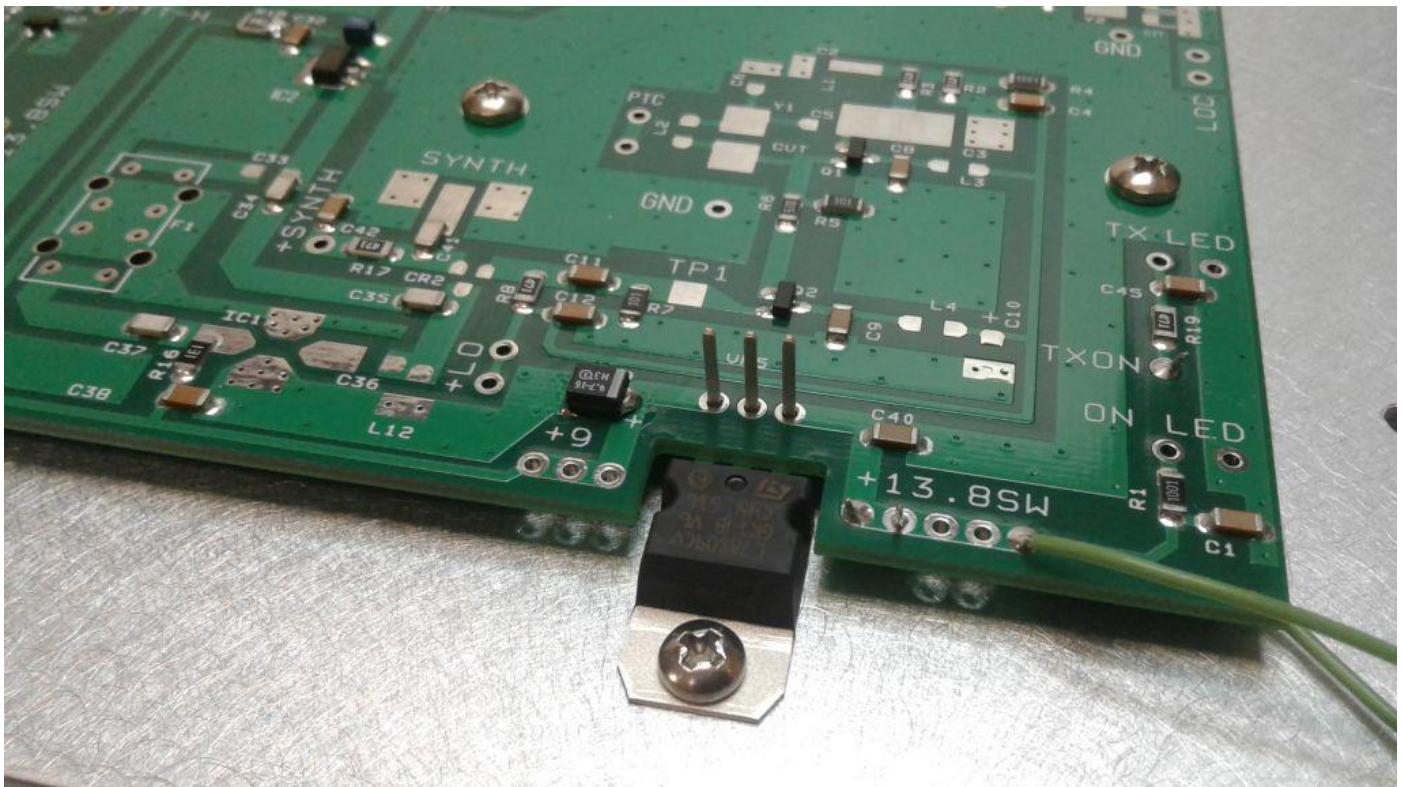

# Q5 SIGNAL VHF/UHF TRANSVERTERS

A Down East Microwave Product Manufactured by Q5 SIGNAL, LLC

## 7. PCB correctly mounted.

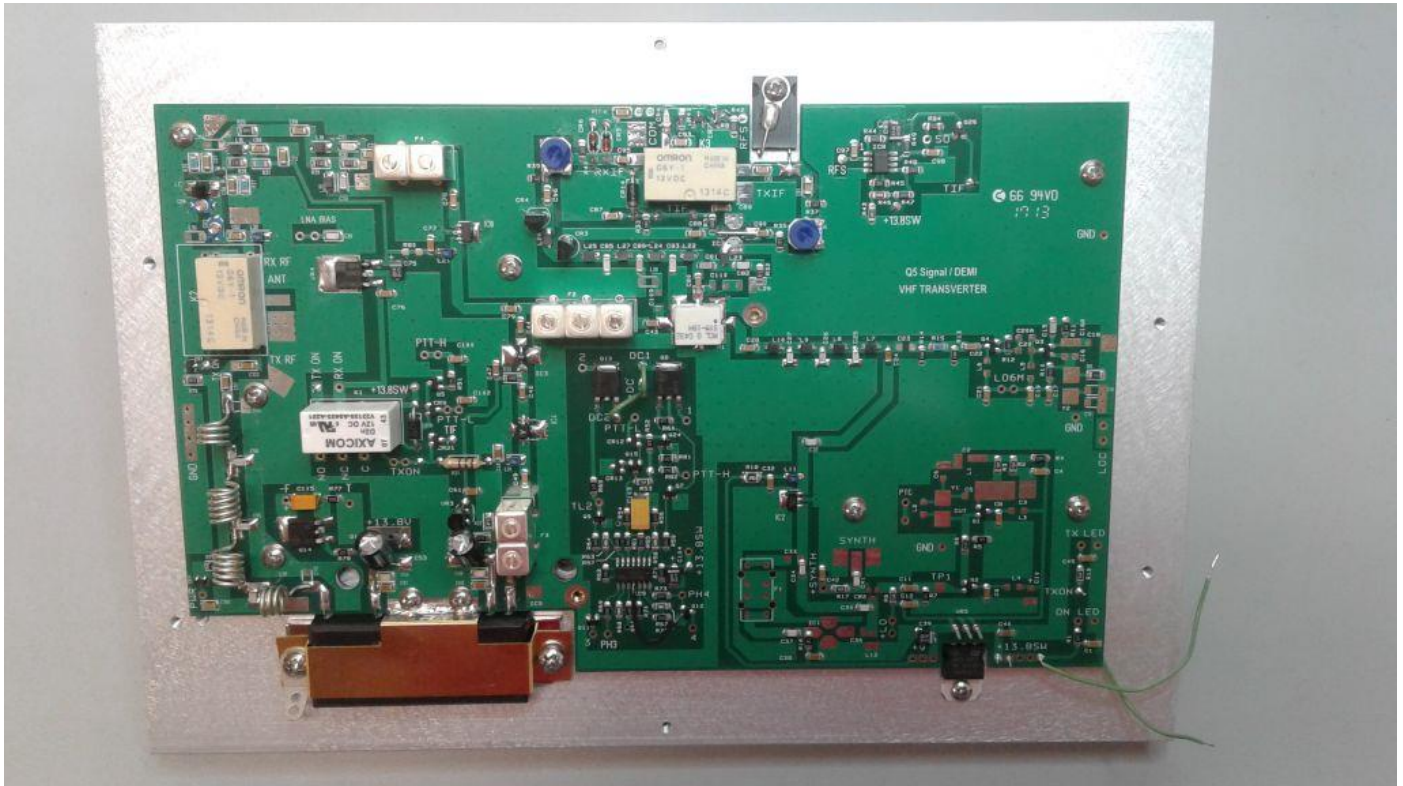

## 8. Low Pass LO filter.

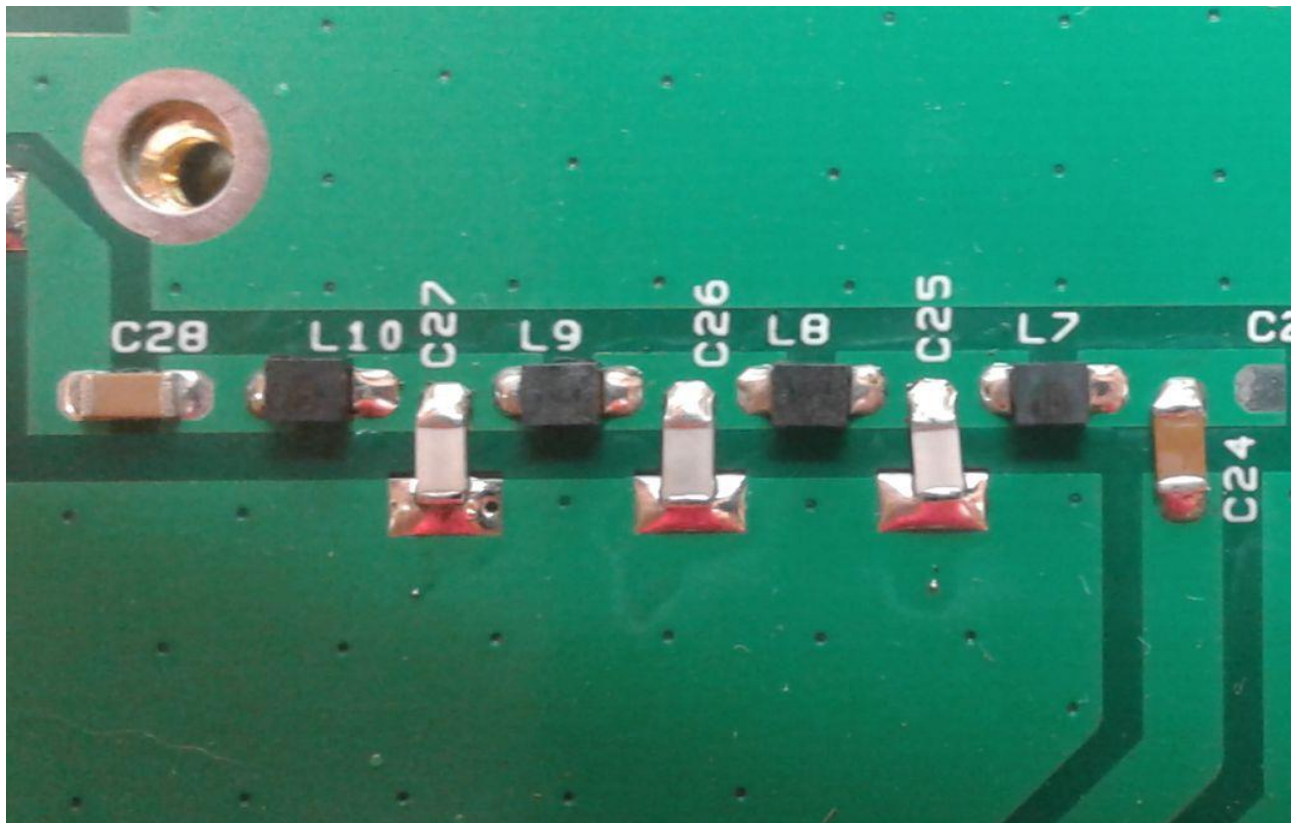



# Q5 SIGNAL VHF/UHF TRANSVERTERS

A Down East Microwave Product Manufactured by Q5 SIGNAL, LLC

## 11. TX load installation.

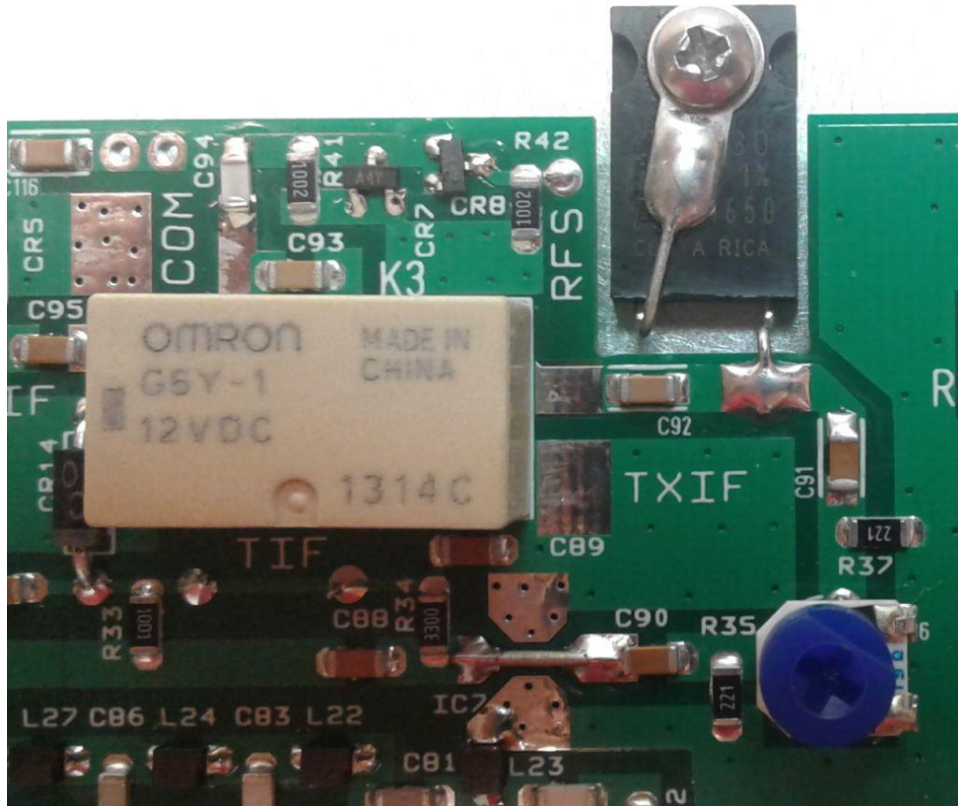

## 12. Sequencer and wiring.

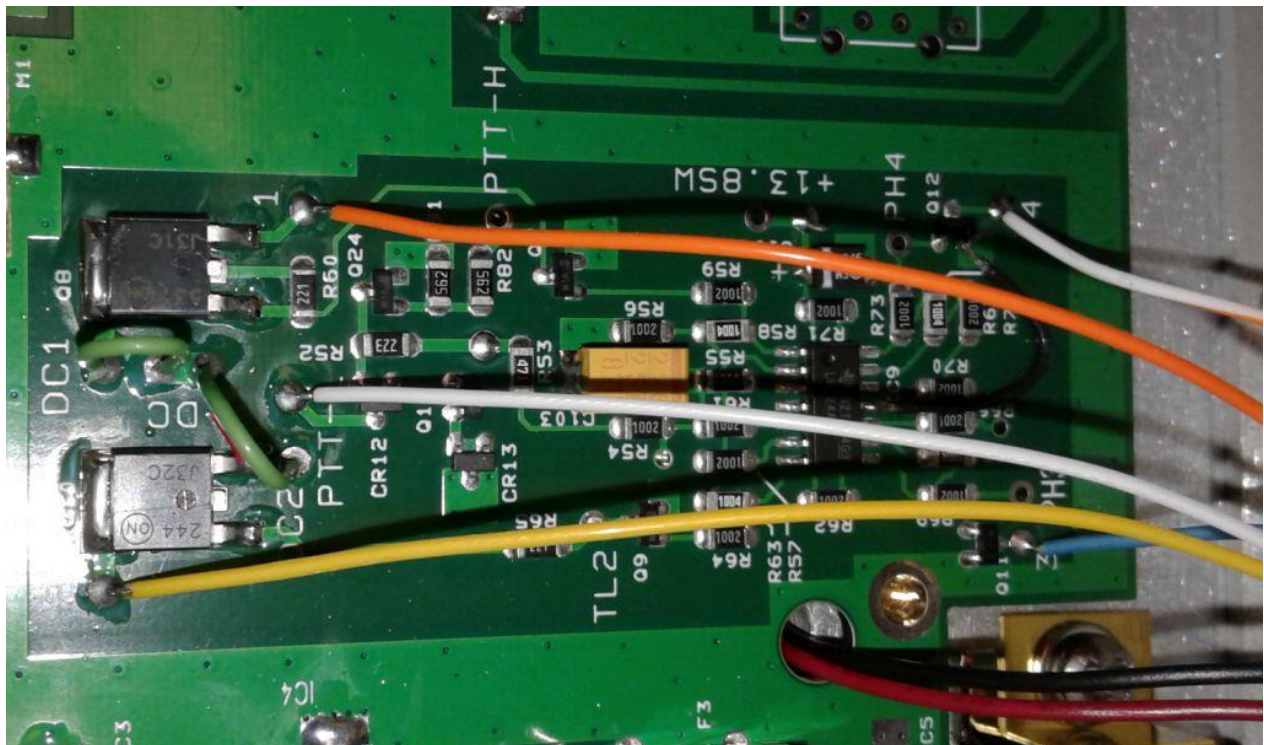

# Q5 SIGNAL VHF/UHF TRANSVERTERS

A Down East Microwave Product Manufactured by Q5 SIGNAL, LLC

## 13. NTC install, Fan and other general wiring.



## 14. TX low pass filter, fan speed and power detect circuit.

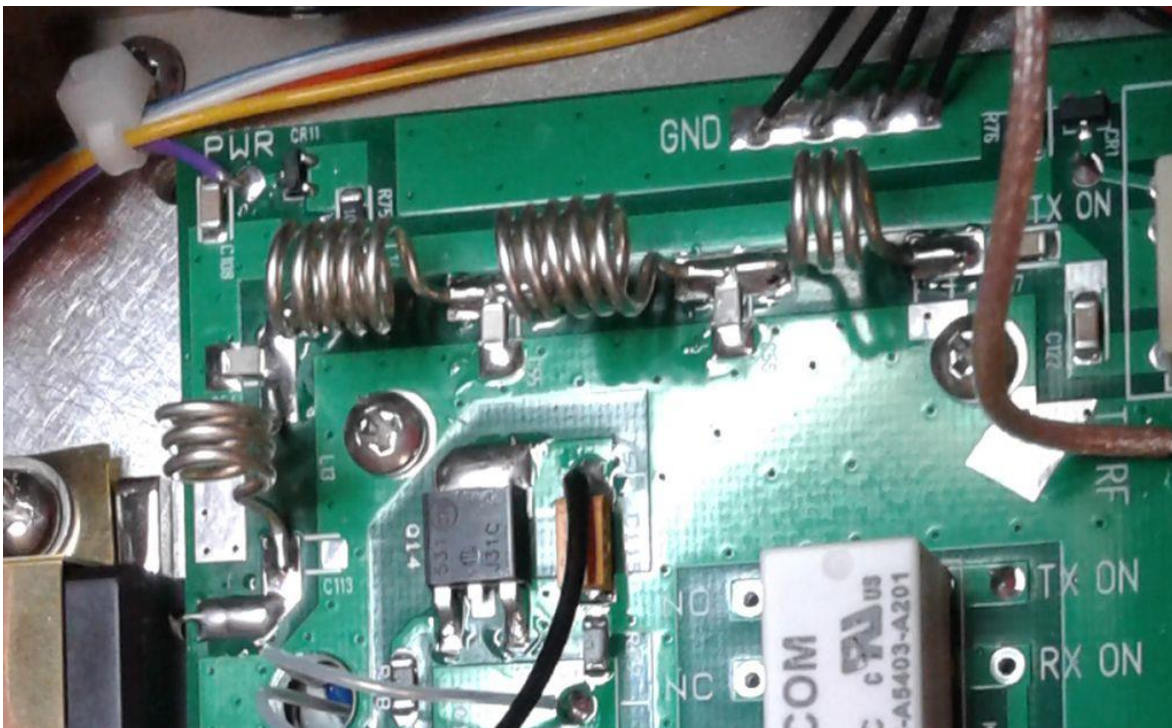

# Q5 SIGNAL VHF/UHF TRANSVERTERS

A Down East Microwave Product Manufactured by Q5 SIGNAL, LLC

## 15. Generic LNA section assembly. L17 may be different.

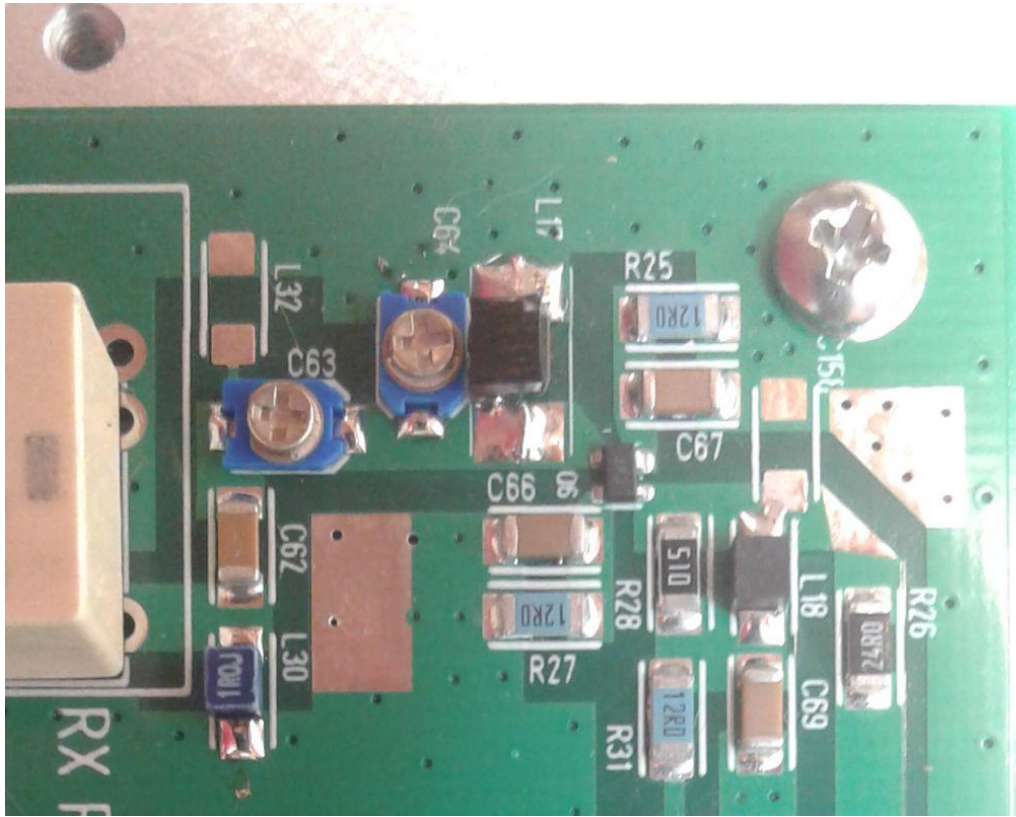

## 16. RX diplexer, gain stage and filter.

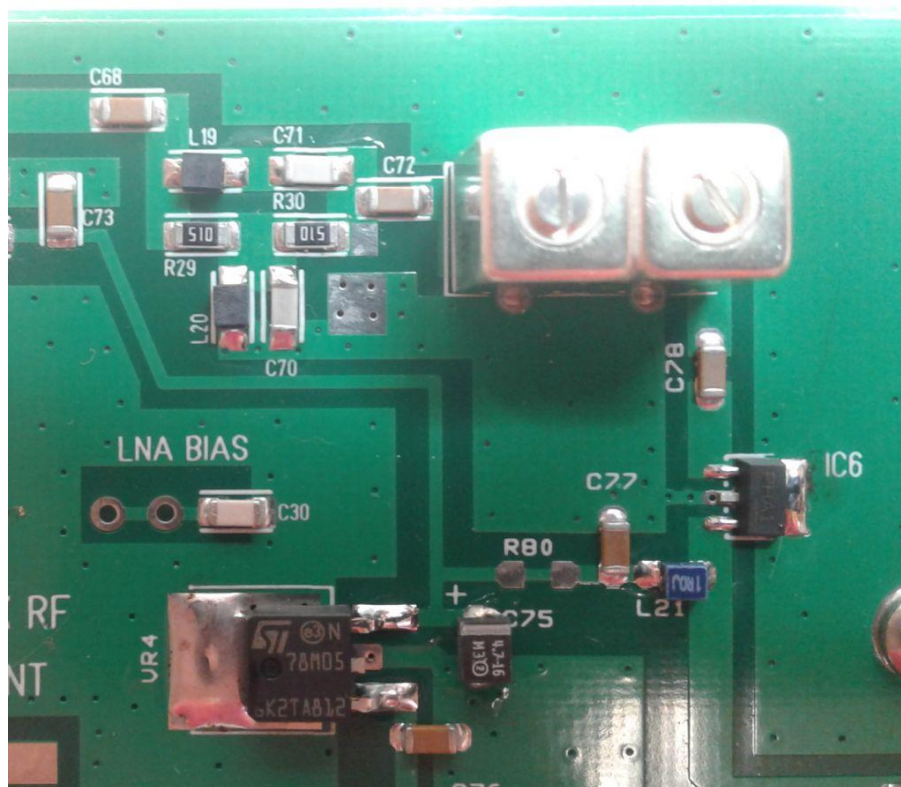



# Q5 SIGNAL VHF/UHF TRANSVERTERS

A Down East Microwave Product Manufactured by Q5 SIGNAL, LLC

## 17. Power module shield install.

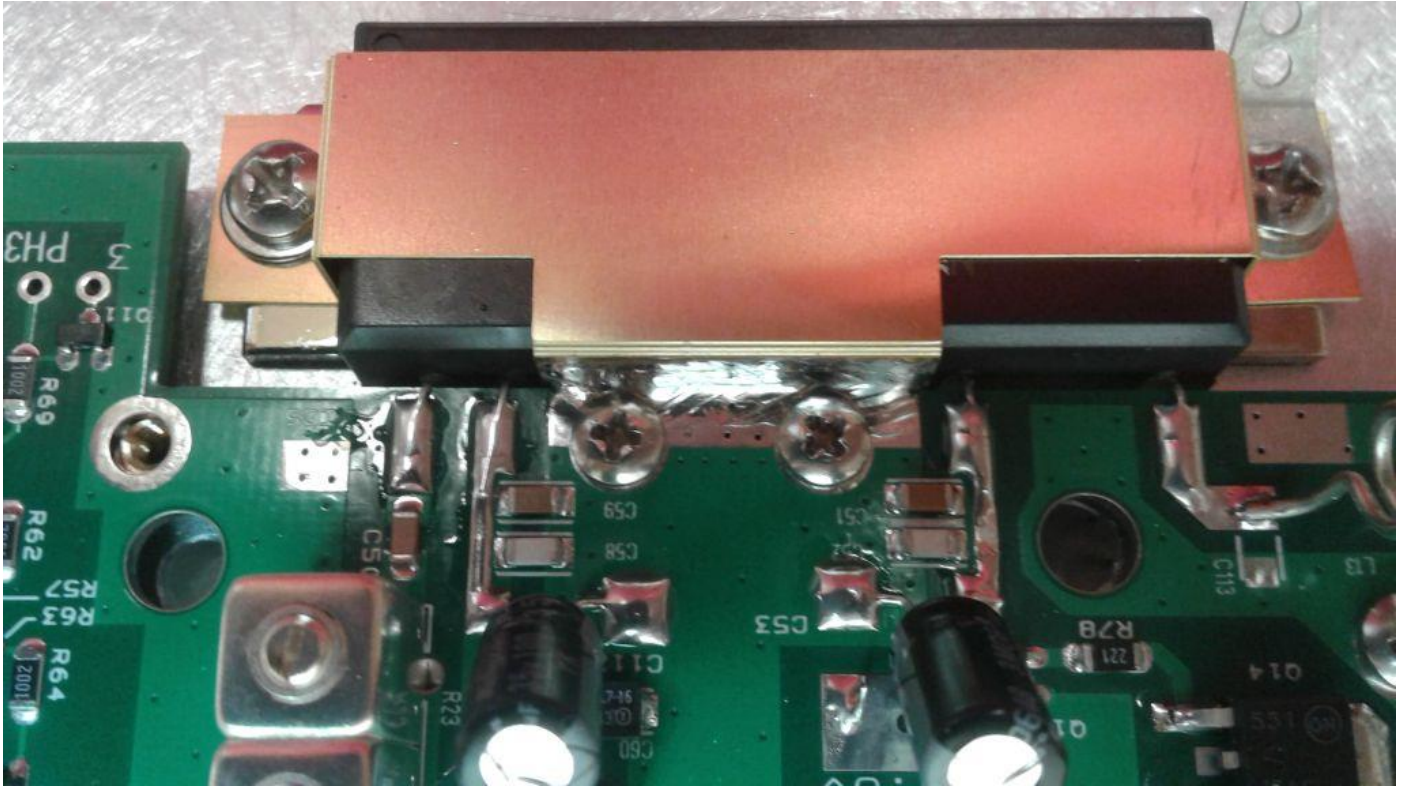

## 18. Connector panel wiring.

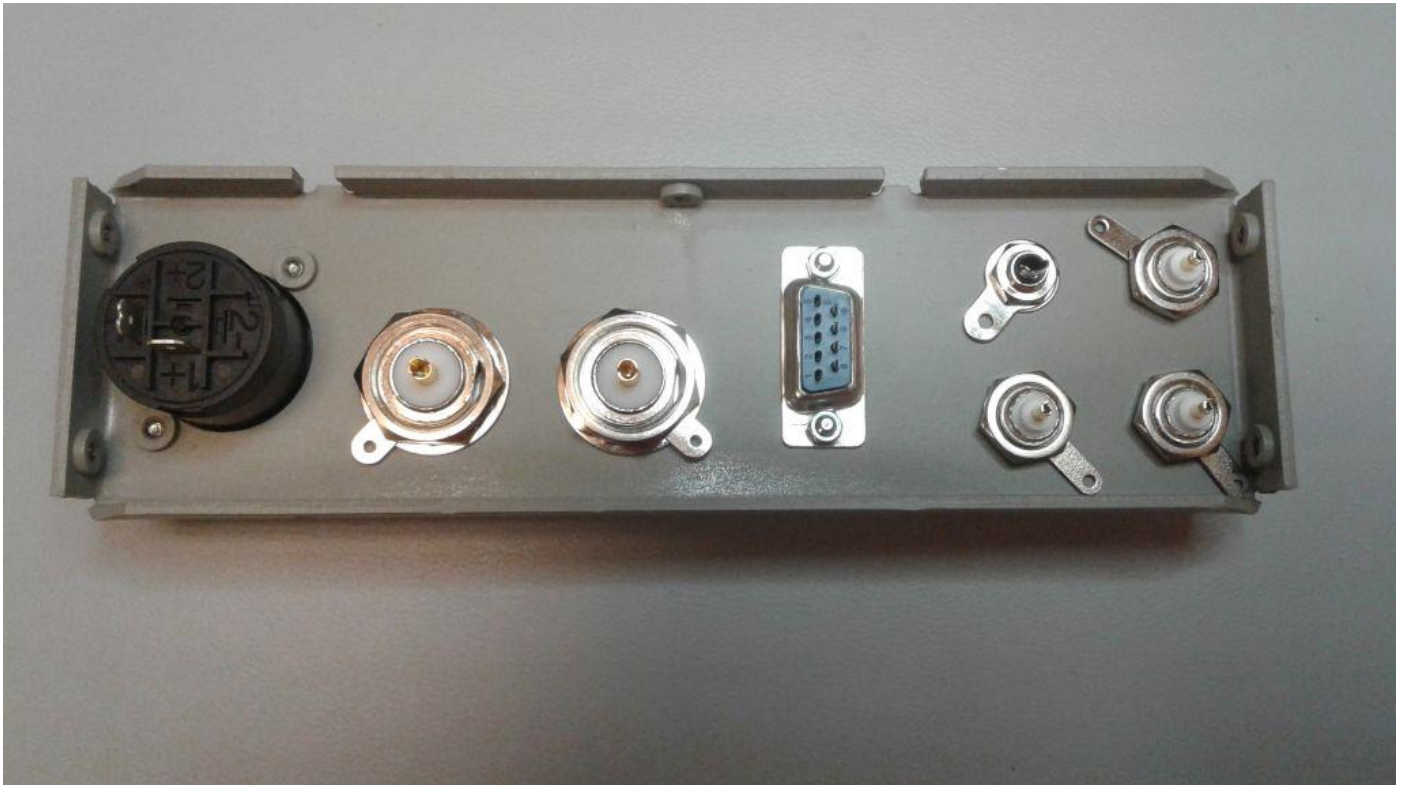

# Q5 SIGNAL VHF/UHF TRANSVERTERS

A Down East Microwave Product Manufactured by Q5 SIGNAL, LLC

## 19. AUX, PTT and ANT connector wiring

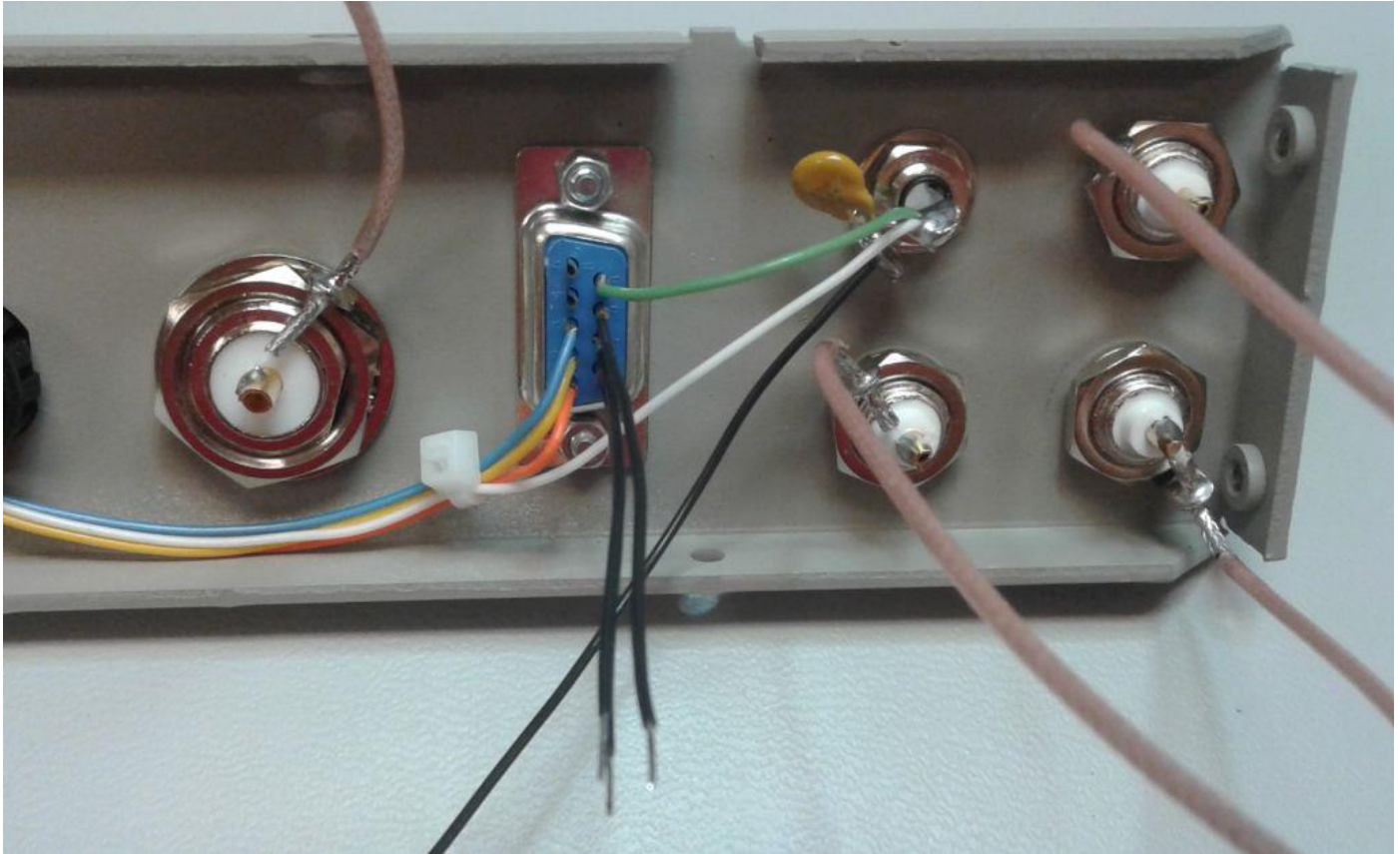

## 20. Rear Panel

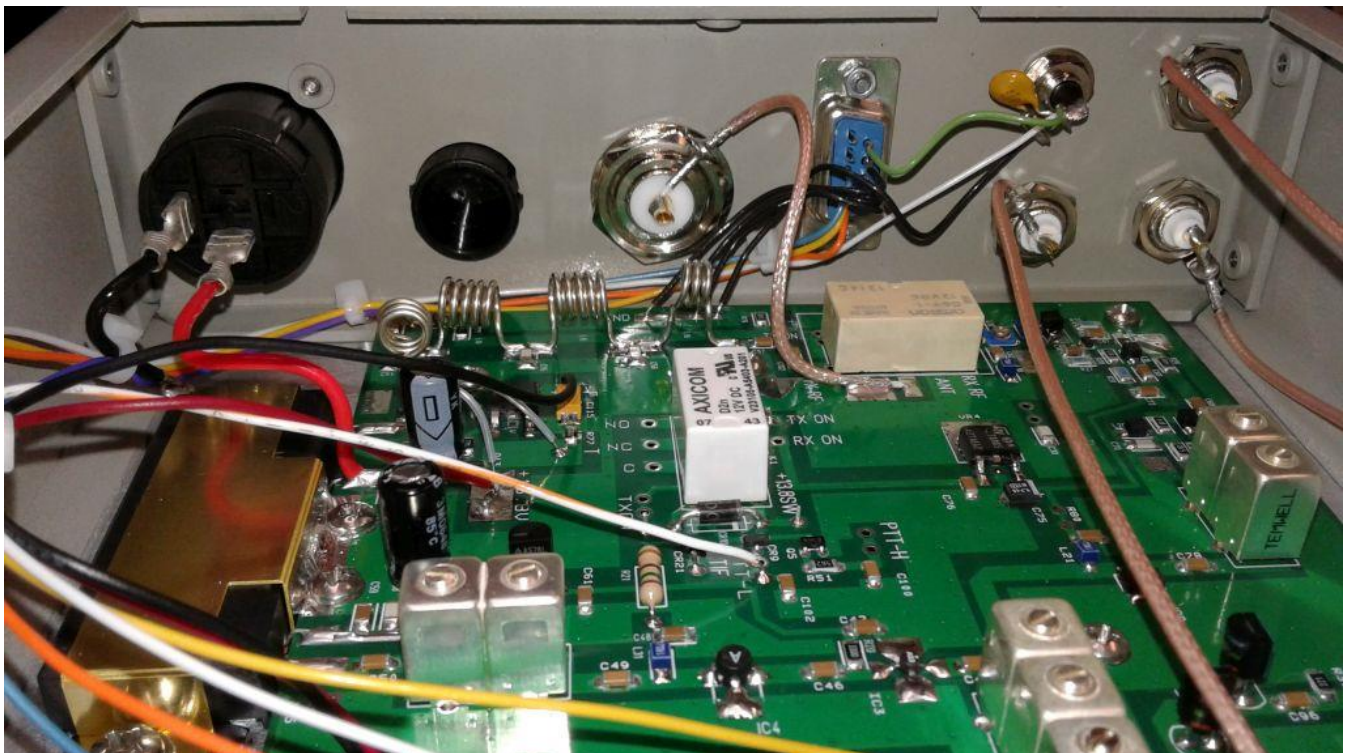

# Q5 SIGNAL VHF/UHF TRANSVERTERS

A Down East Microwave Product Manufactured by Q5 SIGNAL, LLC

## 21. Power meter install, front panel wiring and LO shield install.

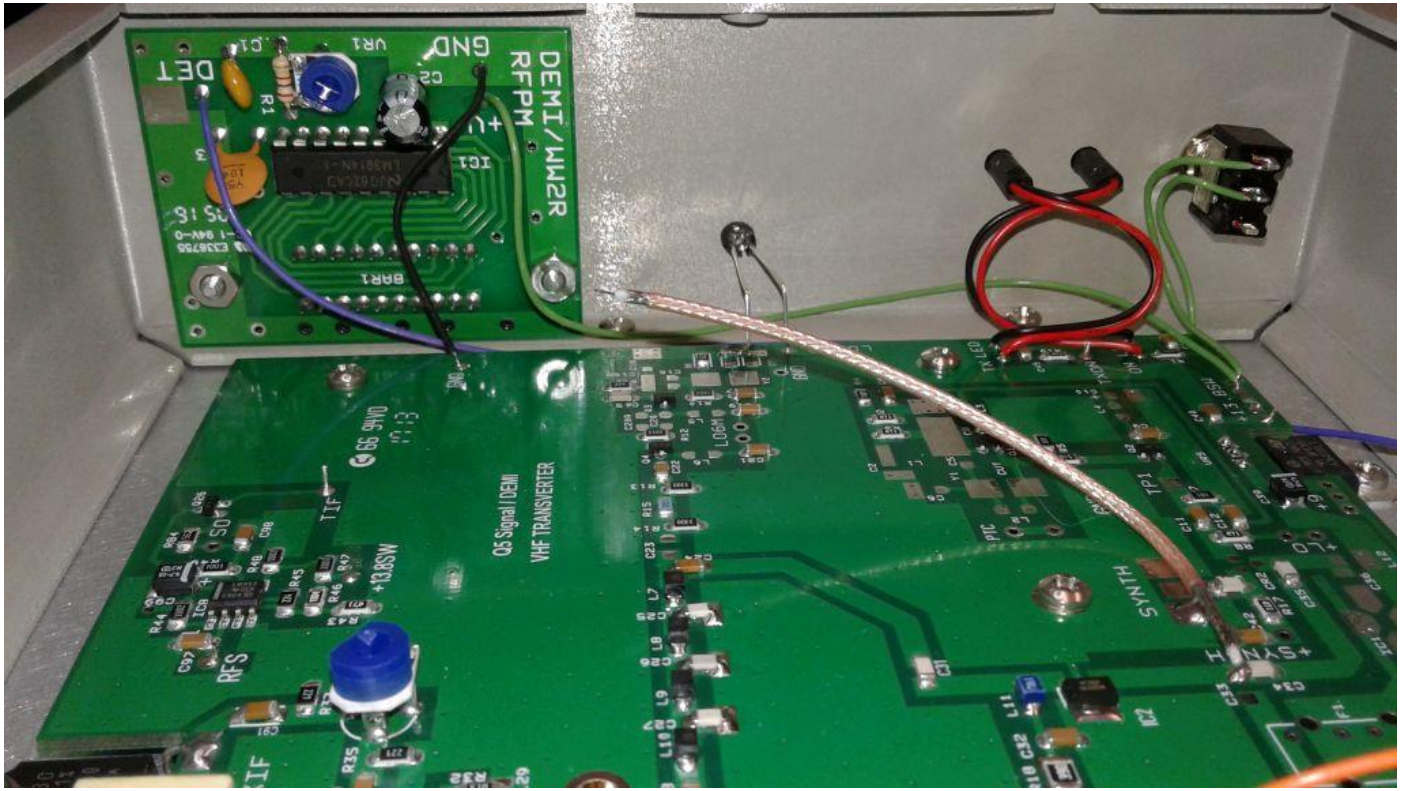

## 22. Inside view of before synth install.

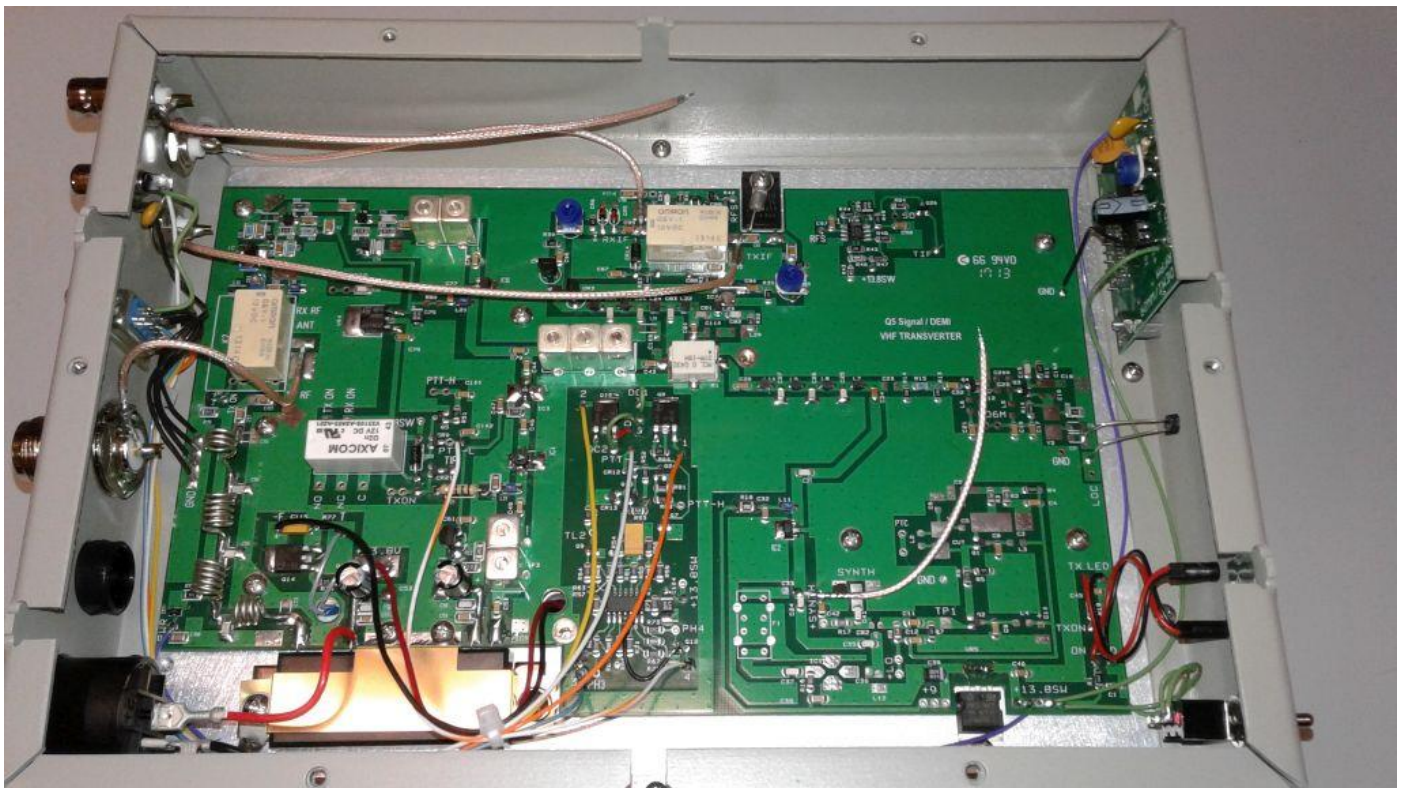



# Q5 SIGNAL VHF/UHF TRANSVERTERS

A Down East Microwave Product Manufactured by Q5 SIGNAL, LLC

## 25. Front view of transverter.

