

INSTRUCTION MANUAL

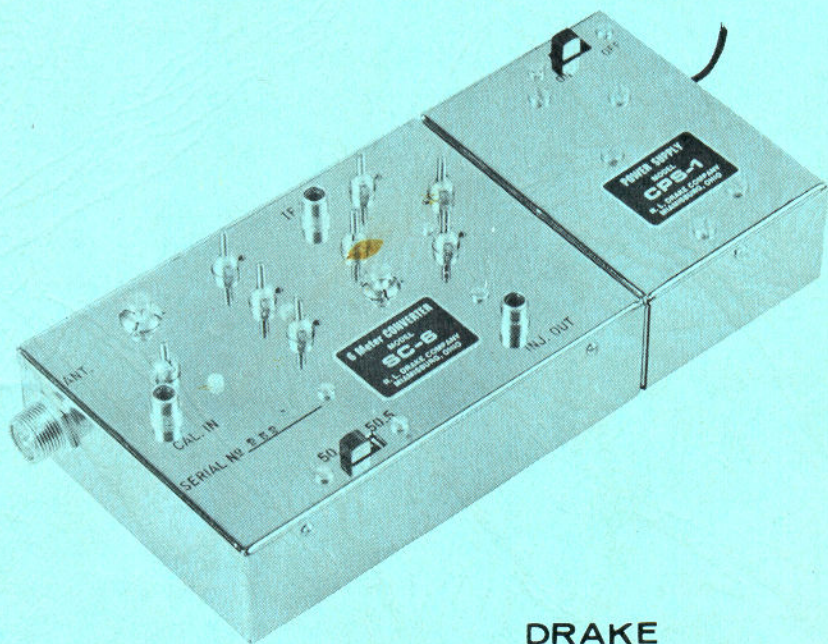

DRAKE

MODEL

SC-6

6 Meter Converter

Price of manual \$2.00

DRAKE MODEL SC-6 CONVERTER

SPECIFICATIONS

| | |
|---------------------------|--|
| FREQUENCY RANGE ----- | 49.5 - 54 MHz |
| I.F. RANGE ----- | 13.5 - 17.5 MHz |
| POWER ----- | 15 - 18 volts DC at 40 ma |
| INPUT IMPEDANCE ----- | 50 ohms |
| OUTPUT IMPEDANCE ----- | 50 ohms |
| IMAGE REJECTION ----- | 75 dB at 22.0 MHz |
| I.F. REJECTION ----- | 80 dB at 14.0 MHz |
| GAIN ----- | 20 dB Typical |
| GAIN VARIATION ----- | \pm .5 dB between 49.5 and 53.5 MHz, down 3 dB at 54 MHz. |
| NOISE FIGURE ----- | 2.5 dB Typical |
| FREQUENCY TOLERANCE ----- | .003% |

SEMI-CONDUCTOR COMPLEMENT

| | |
|------------------|------------------------------|
| 2 - TIS88 ----- | R.F. Amplifier |
| 1 - TIS88 ----- | Mixer |
| 1 - 2N3394 ----- | Oscillator |
| 1 - 1N714 ----- | Zener Regulator |
| 1 - 1N4148 ----- | Reverse Polarity Protection. |

CIRCUIT DESCRIPTION

The SC-6 Converter consists of a cascode FET radio frequency amplifier (Q2 and Q3), a grounded gate FET mixer (Q4) and a series resonant 36 MHz crystal controlled oscillator (Q1).

A signal from the antenna is matched into the gate of Q2 by a tuned circuit consisting of L2 and C6. From the RF amplifier the signal is fed through a bandpass network to the source of mixer Q4. The local oscillator signal is inductively coupled to the gate of mixer Q4.

The difference frequency (13.5 to 17.5 MHz) appearing at the drain of Q4 is matched to the 50 ohm output by the bandpass network formed by L9, C23, C27, C28, and L12.

INJECTION

Approximately 100 millivolts of 36 MHz signal is available at the INJ socket for use with a transmitting mixer. Connection of a load to the INJ socket may necessitate retuning of L6 and L8.

CALIBRATION

A signal level of approximately 5 microvolts applied to the CAL socket is adequate for calibration.

OPERATION

Connect a 6 meter antenna to the ANT connector of the SC-6. Connect the receiver antenna terminals to the IF OUT socket of the SC-6 with RG-58/U coaxial cable. Connect a source of 18 volts DC to the power plug of the SC-6. The cable between the SC-6 and the receiver must be kept as short as possible. A ground strap is provided with the Drake Model CPS-1 Power Supply to give mechanical rigidity and to minimize 14 MHz interference. Connect this strap between the SC-6 and the CPS-1.

Set the slide switch on the SC-6 to 50. The SC-6 will now receive 50 MHz signals with the receiver tuned to 14 MHz. Changing the slide switch to 50.5 selects an alternate local oscillator crystal and allows reception of 50.5 MHz signals with the receiver tuned to 14 MHz.

ALIGNMENT

Alignment of the SC-6 converter requires precision equipment and a working knowledge of bandpass alignment procedures. The minimum equipment required for alignment includes a sweep generator, a sensitive oscilloscope, a signal generator, a video detector, and 50 ohm attenuators to properly terminate the input and output circuits of the converter.

The SC-6 is factory aligned and any attempt at peaking the adjustments will result in destruction of the 4 MHz bandpass characteristic.

The converter may be returned to the factory for alignment for a fixed charge of \$5.00 (U.S. Funds) plus postage. The factory alignment procedure is available upon request.

Alignment of the local oscillator injection, L6 and L8, may be accomplished without affecting the bandpass alignment of the converter. These elements are adjusted for maximum converter gain.

ACCESSORIES

Accessories available for use with the SC-6 include a matching power supply (Model CPS-1), a 50 KHz VHF calibrator (Model SCC-1) and a converter mounting console (Model CC-1). The CC-1 has provisions for mounting the CPS-1, the SCC-1, the SC-6, the SC-2 meter converter, and an extra converter. These accessories are available from your dealer.

USING SC-6 WITH DRAKE R-4B AND 2-C RECEIVERS

Table 1, Page 5, shows the combination of receiver crystals, I.F. tuning range, and 6 meter input frequencies for use with the Drake R-4B and 2-C Receivers.

CHANNEL 2 INTERFERENCE

The SC-6 has been designed to minimize interference from channel 2 transmitters. However, the partially suppressed lower sideband of these transmitters falls inside the 6 meter amateur band and a considerable amount of power is radiated within the band. The degree of lower sideband suppression of the channel 2 transmitter may be checked by observing the signal radiated at 50.750 MHz (suppressed lower sideband sound carrier).

The SC-6 is aligned at the factory with a 4 MHz bandpass (49.5 - 53.5 MHz) and with two channel 2 traps (L1, C5 set at 55.250 MHz and L10, C26 set at 57.750 MHz). In areas with extremely strong channel 2 signals, some interference may be noted in the 50 to 50.5 MHz portion of the band. This interference is caused by high order intermodulation products generated by components of the channel 2 signal radiated near 54 MHz. This interference can usually be eliminated by adjusting the mixer trap C26, L10 to 55.250 MHz. If no signal generator is available, the trap may be adjusted by rotating C26 exactly one turn clockwise. This adjustment will reduce the converter gain within the upper 2 MHz bandpass of the converter (52 to 54) MHz. However, if the channel 2 signal is strong enough to generate this type of interference, the upper 2 MHz of the 6 meter band will not be useful anyway.

It is possible for a channel 2 transmitter with poor lower sideband suppression to radiate energy throughout the entire 6 meter band. This condition may be checked by inserting an R.L. Drake Company model TV-100-LP or TV-1000-LP low pass filter between the SC-6 converter and the antenna. If the interference is still observed, it may be assumed that it is due to channel 2 radiation in the low end of the 6 meter band.

When the SC-6 is used with an R-4B Receiver in the 14.0 to 14.5 MHz range, a CW signal will be heard at 50.2 MHz. This signal is the 2nd harmonic of the R-4B crystal oscillator, 25.1 MHz. If this signal is undesirable, an auxiliary crystal (24.6 MHz) may be installed in the R-4B so that an IF range from 13.5 to 14.0 MHz may be used to receive 50.0 MHz when the slide switch is in the 50.5 MHz position.

FOR DRAKE MODEL R-4B RECEIVER

| | | 6 METER BAND (MHz) | | | | | |
|------------------|--------------------------|--------------------------|-------------|-------------|-------------|-------------|--|
| | | 50 | 51 | 52 | 53 | 54 | |
| CONVERTER SWITCH | 50.0 | Receiver Frequency (MHz) | 14.0 - 14.5 | 15.0 - 15.5 | 16.0 - 16.5 | 17.0 - 17.5 | |
| | R-4B Crystal (MHz) | 25.1* | 26.1 | 27.1 | 28.1 | | |
| 50.5 | Receiver Frequency (MHz) | 14.0 - 14.5 | 15.0 - 15.5 | 16.0 - 16.5 | 17.0 - 17.5 | | |
| | R-4B Crystal (MHz) | 25.1* | 26.1 | 27.1 | 28.1 | | |

NOTE: * The 25.1 MHz crystal, supplied with the R-4B Receiver, covers 50 - 51 MHz. The 26.1 MHz crystal along with the 25.1 MHz crystal covers 50 - 52 MHz. Auxiliary crystals 27.1 and 28.1 MHz along with 25.1 and 26.1 MHz crystals will cover the entire 6 meter band.

FOR DRAKE MODEL 2-C RECEIVER

| | | 6 METER BAND (MHz) | | | | | |
|------------------|--------------------------|--------------------------|-------------|-------------|-------------|-------------|--|
| | | 50 | 51 | 52 | 53 | 54 | |
| CONVERTER SWITCH | 50.0 | Receiver Frequency (MHz) | 14.0 - 14.5 | 15.0 - 15.5 | 16.0 - 16.5 | 17.0 - 17.5 | |
| | 2-C Crystal (MHz) | 18.0* | 19.0 | 20.0 | 21.0 | | |
| 50.5 | Receiver Frequency (MHz) | 14.0 - 14.5 | 15.0 - 15.5 | 16.0 - 16.5 | 17.0 - 17.5 | | |
| | 2-C Crystal (MHz) | 18.0* | 19.0 | 20.0 | 21.0 | | |

NOTE: * The 18.0 MHz crystal supplied with the 2-C Receiver covers 50 - 51 MHz. The 19.0 MHz crystal, along with the 18.0 MHz crystal covers 50 - 52 MHz. Auxiliary crystals 20.0 and 21.0 MHz, along with 18.0 and 19.0 MHz crystals will cover the entire 6 meter band.

TABLE 1.

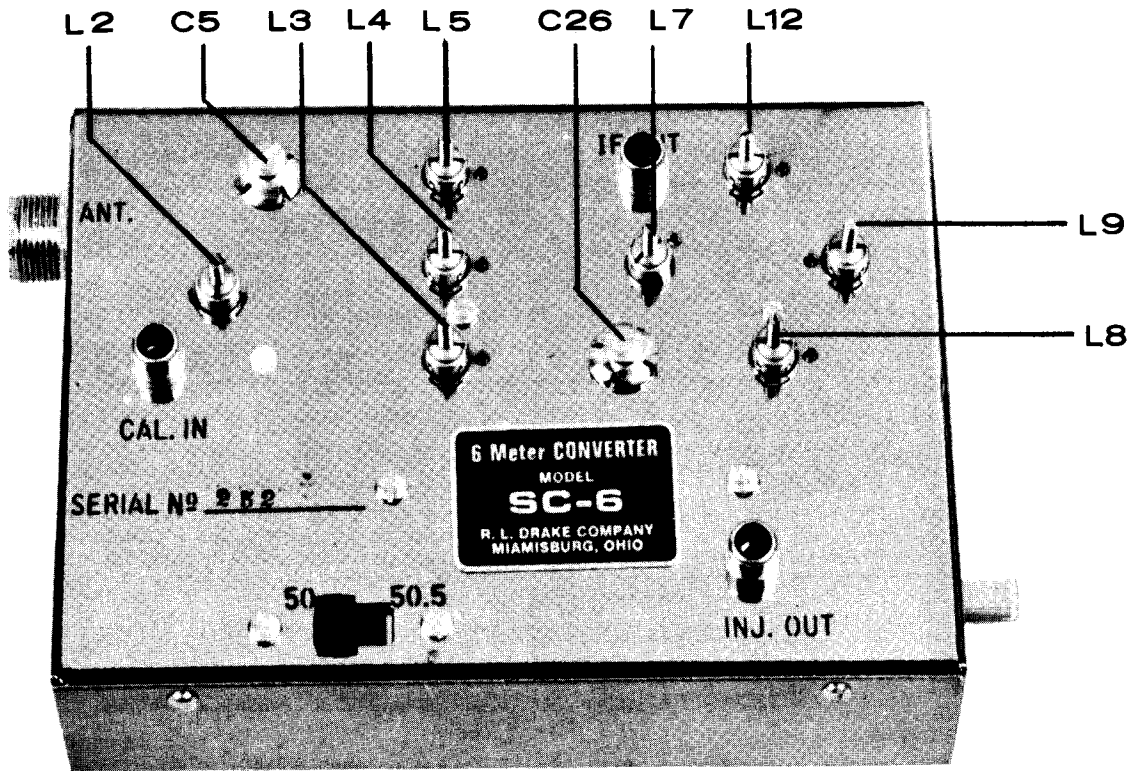
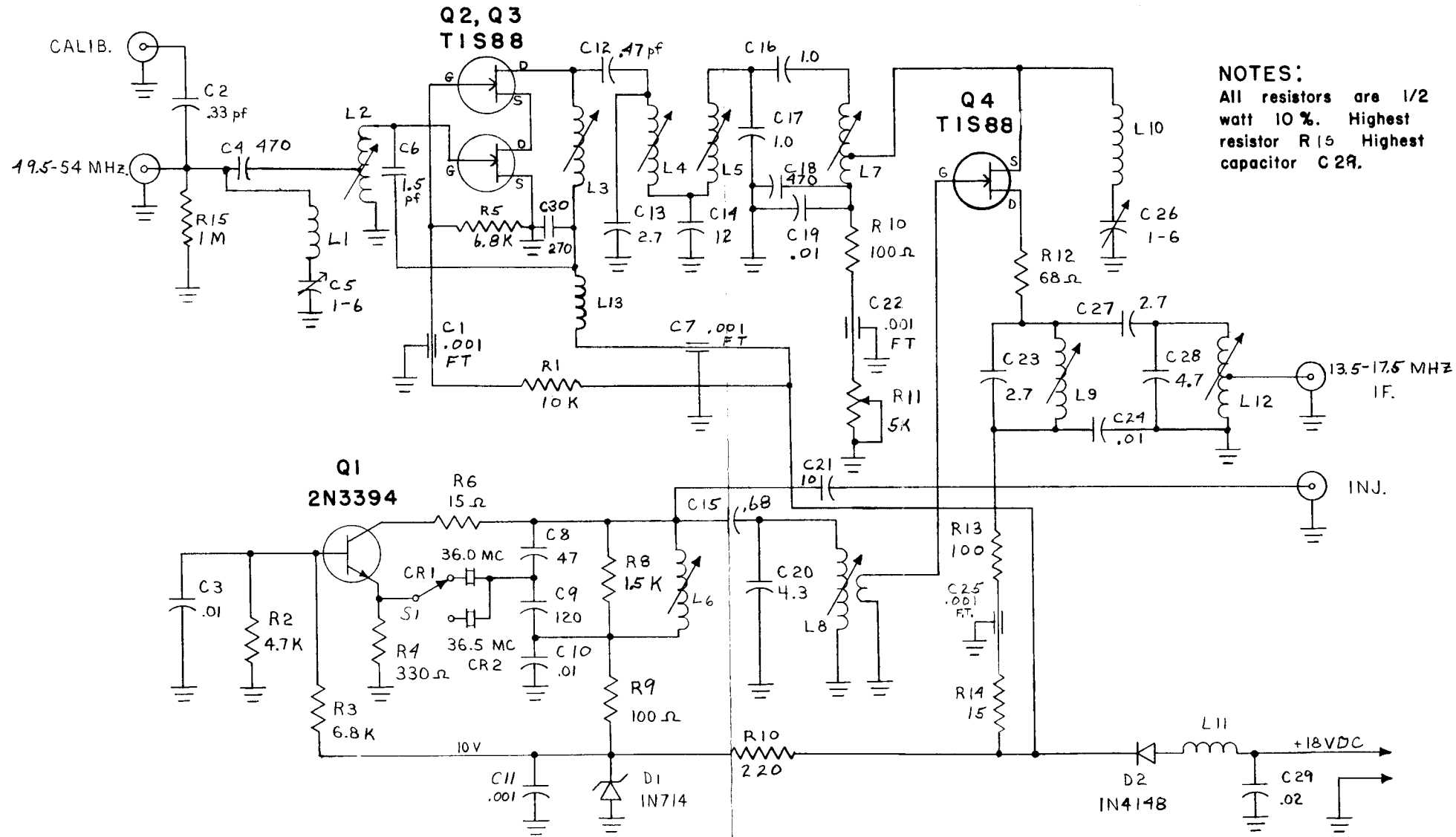

FIGURE 1 TUNING CONTROLS



NOTES:
 All resistors are 1/2 watt 10%. Highest resistor R15. Highest capacitor C29.

SCHEMATIC DIAGRAM MODEL SC-6 CONVERTER

STANDARD WARRANTY

R. L. Drake Company warrants each new radio product manufactured by it to be free from defective material and workmanship and agrees to remedy any such defect or to furnish a new part in exchange for any part of any unit of its manufacture which under normal installation, use, and service discloses such defect, provided the unit is delivered by the owner to us or to our authorized radio dealer or wholesaler from whom purchased, intact, for our examination, with all transportation charges prepaid to our factory, within ninety days from the date of sale to original purchaser and provided that such examination discloses in our judgement that it is thus defective. Should a malfunction be suspected, write in detail to our Service Department for suggestions concerning the operation, repair or return of your unit if it should prove necessary.

This warranty does not extend to any of our radio products which have been subjected to misuse, neglect, accident, incorrect wiring not our own, improper installation, or to use in violation of instructions furnished by us, nor extend to units which have been repaired or altered outside our factory, nor in cases where the serial number thereof has been removed, defaced or changed, nor to units used with accessories not manufactured or recommended by us.

Any part of a unit approved for remedy or exchange hereunder will be remedied or exchanged by the authorized radio dealer or wholesaler without charge to the owner.

This warranty is in lieu of all other warranties expressed or implied and no representative or person is authorized to assume for us any other liability in connection with the sale of our radio products.

The R. L. Drake Company reserves the right to make any improvements to its products which it may deem desirable without obligating itself to install such improvements in its previously manufactured products.