

50/28 MHz TRANSVERTER BOARD

With this Transverter board you can work on **6 meter** band using any type of the HF radio that has **10 meter** band. It would work the whole 6 meter band at **50 to 54 MHz** if your base radio has the **28 to 32 MHz** band. Most HF radios have 28 to 30 MHz band so in this case it means you would have the 50 to 52 MHz band. **It works any modes such SSB, CW or FM if its available in your radio.**

Technical specifications

- RF range - **50 ... 54 MHz**
- IF range - **28 ... 32 MHz**
- IF input power - **1 ... 50 mW (0.05 W max.) or 0 ... 17 dBm**
- LO frequency - **22 MHz**
- Output power - **10 W**
- RX gain - **typ. 20 dB**
- Noise figure - **typ. 1.0 dB**
- Image rejection - **typ. 70 dB**
- PTT control - **Contact closure to the ground**
- Supply voltage - **+13.8 VDC (+12 ... 14 VDC)**
- Current consumption - **typ. 1.3 A (TX)**

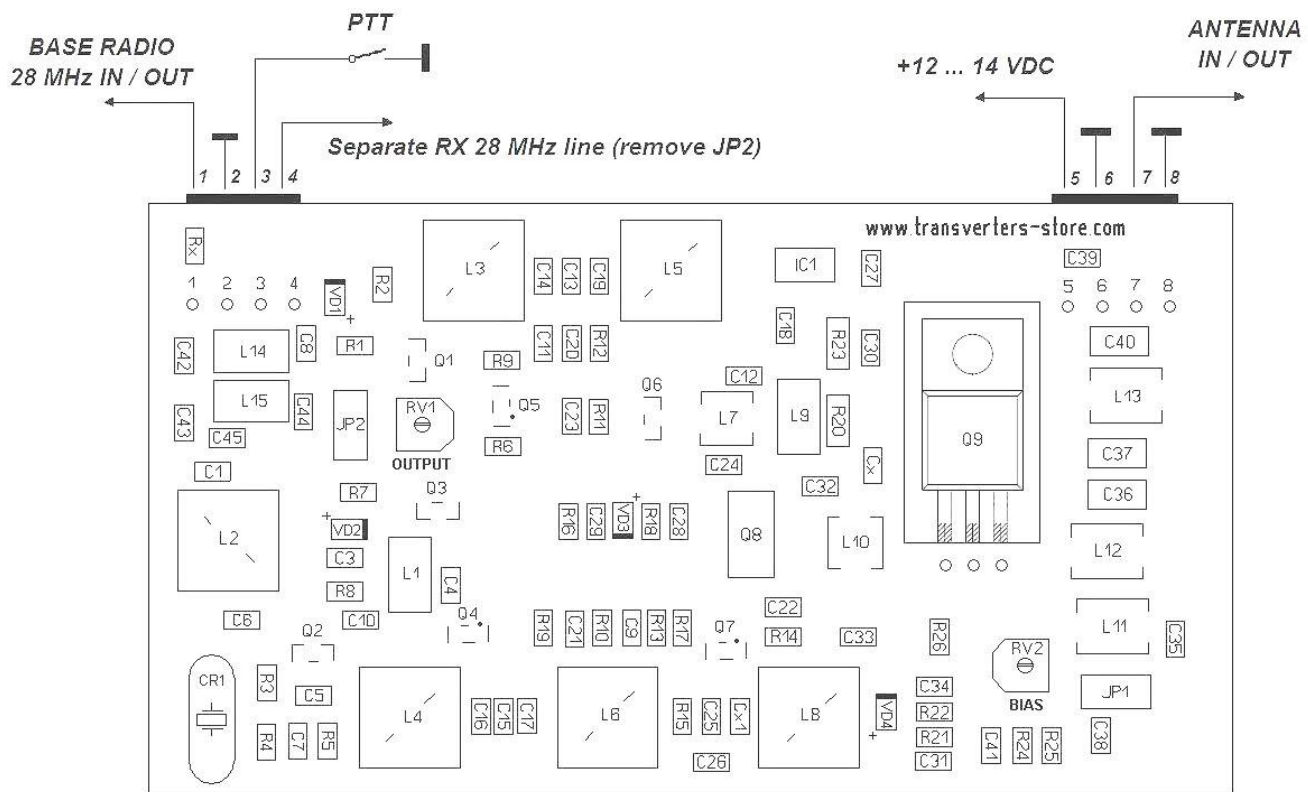

Pinout of the connectors:

1. IF 28 MHz transverter input/output line
2. Ground
3. PTT line (**ground it to switch the Transverter to the TX mode**)
4. **Separate RX 28 MHz line (remove JP2)**
5. +12 V
6. Ground
7. Antenna 50 MHz
8. Ground

To read the tips below and mount your transverter EXACTLY as it described.

1. **RF input** power to the transverter from your HF radio **should NOT be MORE** than **50 mW (0.05 W max)**. You can adjust it using **RV1** pot on the board.
2. **Initially Transverter set on the common IF 28 MHz RX/TX line on the pin 1.**
3. **Removing JP2 jumper allows you to use RX/TX lines separately (TX pin 1, RX pin 4).**
4. DC supply is **+12 ... 14 VDC**
5. To get the transverter switched to the **TX** mode close the **PTT** line to the **ground**.
6. **RV1** pot adjusts **OUTPUT POWER** of the Transverter.
7. **RV2** pot adjusts **BIAS** of the output transistor.

The transverter board suppose to be mounted onto heat sink.

Using the metal bolts screw down the transistor onto the heat sink and then put a few nuts or washers under both mounting holes between the board and the heat sink so to get the board flat mounted above the heat sink about a few millimetres. Or you can use the pieces of plastic between the board and heatsink under mounting holes drilling the holes in and get the bolts through. Both mounting bolts should have a good contact to the transverter board ground.

The stable work of the transverter depends of this!

The output transistor is mounted onto the heat sink without insulation.

To check mutual GROUND of the output transistor, heat sink and board.

All RF RX and TX lines must be done using good quality coax cable !

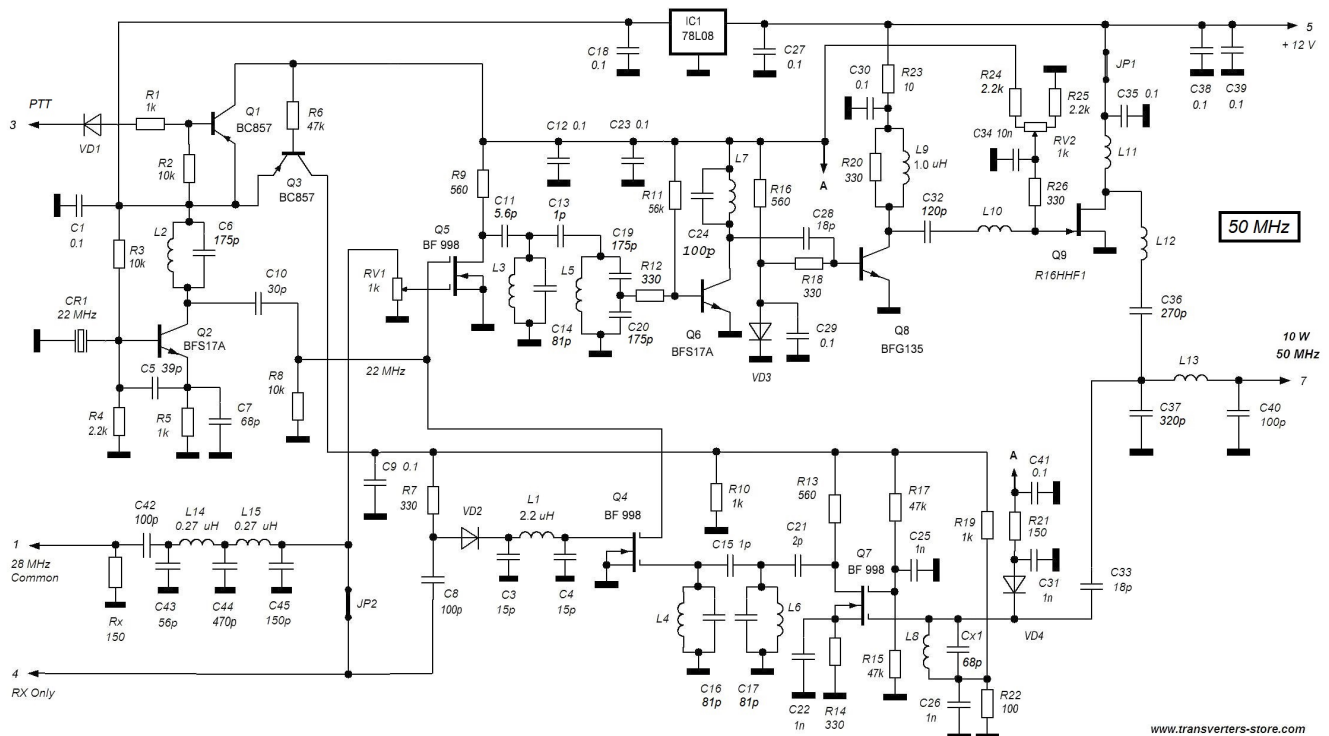

BE CAREFUL! Driving power more than 0.1 W instantly kills the Transverter !

Web Store: <http://transverters-store.com/>

E-mail: ut5jcw@usa.com

Skype: [ut5jcw](https://www.skype.com/user/ut5jcw)

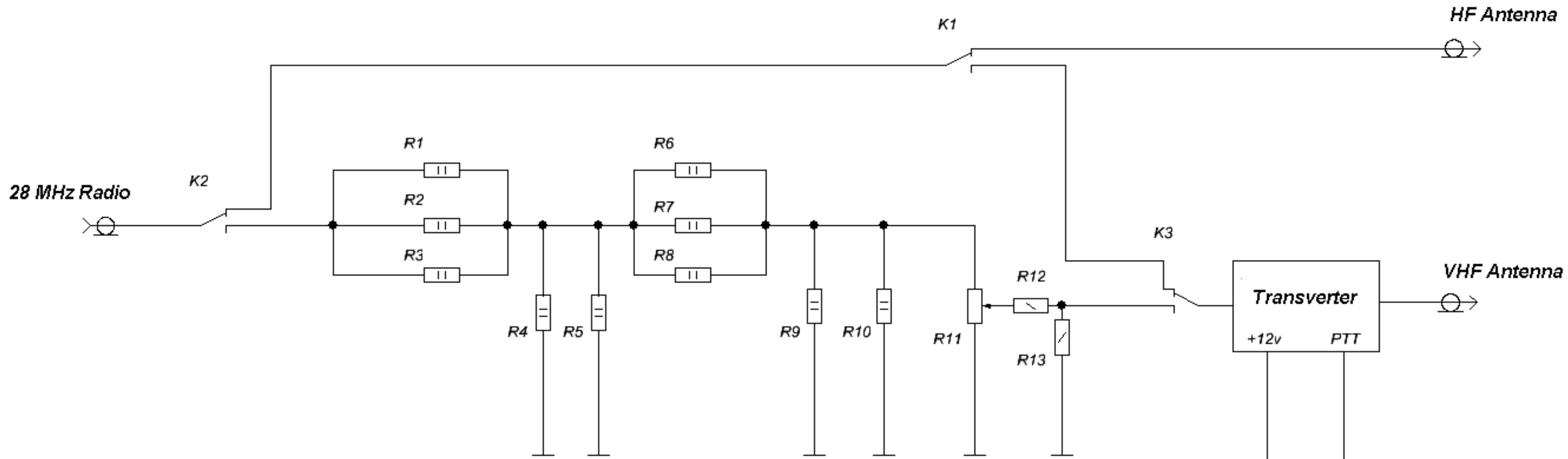

- R1-R8 - 75 ohm (2 W)
- R9, R10 - 200 ohm (2 W)
- R11 - 100 ohm Pot
- R12, R13 - 100 ohm (0.25 W)
- R14 - 1.5 K
- VD1-VD3 - 1N4148
- K1, K2, K3 - 12 V Relays

