



CI-V REFERENCE GUIDE

HF/50 MHz TRANSCEIVER

IC-7760

TABLE OF CONTENTS

REMOTE CONTROL	2
Remote control (CI-V) information.....	2
◇ CI-V connection.....	2
◇ Preparing.....	2
◇ About the data format.....	2
◇ Command table.....	3
◇ Command formats.....	16
• Operating frequency	16
• Operating mode	16
• Codes for CW message contents	16
• Band edge frequency settings	16
• Band stacking register	17
• Memory content.....	18
• Codes for character entries	18
• Keyer memory character entries	19
• Keyer memory content	19
• IF filter width settings.....	19
• AGC time constant settings	19
• RX HPF/LPF settings for each operating mode.....	19
• SSB/SSB-DATA transmission passband width settings.....	19
• Split offset frequency setting.....	20
• [VOX/BK-IN] setting.....	20
• [AUTOTUNE] setting	20
• Remote MIC Key setting.....	20
• IP address setting.....	20
• UTC Offset setting	21
• Color settings.....	21
• Bandscope edge frequency settings	21
• Antenna memory settings.....	21
• Data mode with filter width settings	21
• TX Power Limit setting.....	21
• Repeater tone/tone squelch frequency settings	22
• RIT/ Δ TX frequency settings	22
• Main or Sub band's frequency settings.....	22
• Main or Sub band's operating mode and filter settings	22
• Scope waveform data.....	23
• Spectrum scope mode settings	23
• Scope span settings (in the Center mode and SCROLL-C mode Scope)	24
• Scope Edge number settings (in the Fixed mode and SCROLL-F mode Scope)	24
• Scope Hold settings.....	24
• Scope Reference level settings	24
• Scope Sweep speed settings	24
• Scope VBW (Video Band Width) settings...	24
• Scope RBW (Resolution Band Width) settings	24
• Scope Fixed edge frequency settings	25
• Directly specify the Main or Sub band and send/read the supported command.....	25

REMOTE CONTROL

Remote control (CI-V) information

◆ CI-V connection

The transceiver's operating frequency, mode, VFO and memory selection, can be remotely controlled using a PC. The Icom Communications Interface V (CI-V) controls the transceiver. Connect the transceiver's controller to a PC with a USB cable (User supplied).

To use the USB cable between the transceiver's controller and a PC, you must first install a USB driver. The latest USB driver and installation guide can be downloaded from the Icom website. Carefully read the guide, before installing the driver.
<https://www.icomjapan.com/support/>

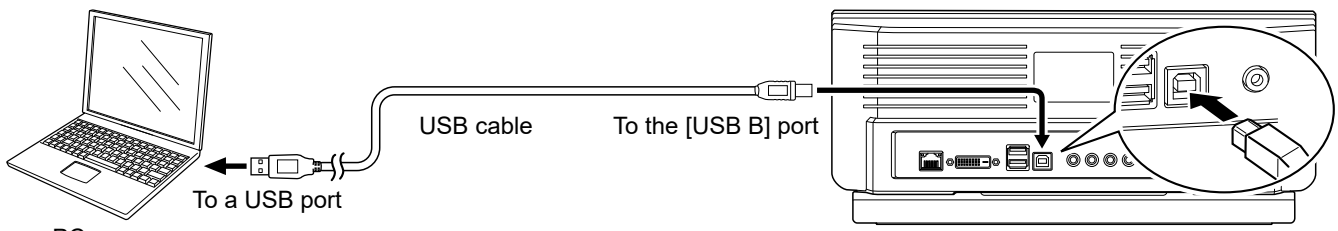

① Make the connection as short as possible. The transceiver may not be recognized by the PC, depending on the USB cable length.

◆ Preparing

The Icom Communications Interface V (CI-V) is used for remote control. To control the transceiver, first set its address, data communication speed*, and transceive function. These settings are set in the Set mode (Refer to the IC-7760 Basic manual).

* This needs to be set when the cable is connected to the [REMOTE] jack on the RF deck's rear panel.

◆ About the data format

The CI-V system can be written using the following data formats. Data formats differ according to command numbers. A data area or sub command is added for some commands.

Controller (PC) to IC-7760

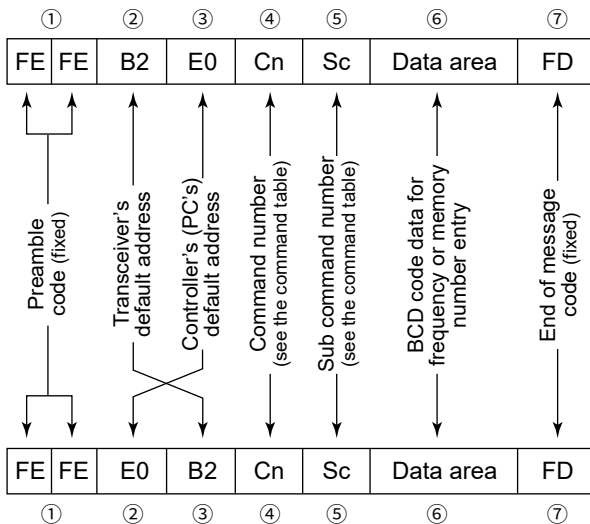

IC-7760 to controller (PC)

OK message to controller (PC)

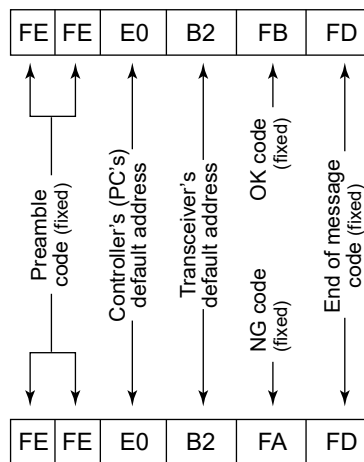

NG message to controller (PC)

REMOTE CONTROL

Remote control (CI-V) information

◇ Command table

Cmd.	Sub cmd.	Data	Description
00		See p. 16.	Send the frequency data (transceive)
01		See p. 16.	Send the mode data (transceive)
02		See p. 16.	Read the band edge frequencies
03		See p. 16.	Read the operating frequency
04		See p. 16.	Read the operating mode
05		See p. 16.	Set the operating frequency
06		See p. 16.	Set the operating mode
07	29		Select the VFO mode
	B0		Exchange Main and Sub bands
	B1		Equalize Main and Sub bands
	C0		Turn OFF Dualwatch
	C1		Turn ON Dualwatch
	C2*	00/01	Send/read the Dualwatch setting (00=OFF, 01=ON)
	D0		Select the Main band
	D1		Select the Sub band
	D2*	00	Send/read Main band selection
		01	Send/read Sub band selection
08			Select the Memory mode
		00 01 ~ 00 99	Select the Memory channel (00 01=M-CH01, 00 99=M-CH99)
		01 00	Select program scan edge channel P1
		01 01	Select program scan edge channel P2
09			Memory write
0A			Memory copy to VFO
0B			Memory clear
0E	00		Cancel the scan
	01		Start a Programmed/memory scan
	02		Start a Programmed scan
	03		Start a ΔF scan
	12		Start a Fine programmed scan
	13		Start a Fine ΔF scan
	22		Start a Memory scan
	23		Start a Select memory scan
	Ax (x=1 ~ 7)		Select ΔF scan span (x=1 (±5kHz), x=2 (±10kHz), x=3 (±20kHz), x=4 (±50kHz), x=5 (±100kHz), x=6 (±500kHz), x=7 (±1MHz))
	B0		Clear the Select channel setting
	B1		Set as select channel ① The previously set number by CI-V is set after turning the power ON, or "1" is selected if no selection is performed.
		01 ~ 03	Set the channel as a Select channel (01=SEL1, 02=SEL2, 03=SEL3)
	B2	00 ~ 03	Set the Select memory scan channel (00=ALL, 01=SEL1, 02=SEL2, 03=SEL3)
	D0		Set Scan resume OFF
D3		Set Scan resume ON (Close&Delay)	
0F		00/01	Read Split setting (00=Split OFF, 01=Split ON)

Cmd.	Sub cmd.	Data	Description
0F	00		Set Split function OFF
	01		Set Split function ON
10*		00 ~ 08	Send/read the tuning step (00=OFF (10Hz or 1Hz), 01=100Hz, 02=1kHz, 03=5kHz, 04=9kHz, 05=10kHz, 6=12.5kHz, 07=20kHz, 08=25kHz)
11*	29	00	Send/read attenuator OFF setting
		03	Send/read 3 dB attenuator setting
		06	Send/read 6 dB attenuator setting
		09	Send/read 9 dB attenuator setting
		12	Send/read 12 dB attenuator setting
		15	Send/read 15 dB attenuator setting
		18	Send/read 18 dB attenuator setting
		21	Send/read 21 dB attenuator setting
		24	Send/read 24 dB attenuator setting
		27	Send/read 27 dB attenuator setting
		30	Send/read 30 dB attenuator setting
		33	Send/read 33 dB attenuator setting
		36	Send/read 36 dB attenuator setting
		39	Send/read 39 dB attenuator setting
		42	Send/read 42 dB attenuator setting
		45	Send/read 45 dB attenuator setting
12*	29	00*2	Select/read ANT1 selection (00=RX ANT OFF, 01=RX ANT ON)
		01*2	Select/read ANT2 selection (00=RX ANT OFF, 01=RX ANT ON)
		02*2	Select/read ANT3 selection (00=RX ANT OFF, 01=RX ANT ON)
		03*2	Select/read ANT4 selection (00=RX ANT OFF, 01=RX ANT ON)
13	00		Speak all data by the voice synthesizer (S meter level, frequency, and mode)
	01		Speak the operating frequency and S meter level by voice synthesizer
	02		Speak the operating mode by voice synthesizer ① The mode is announced after the ongoing speech.
14*	01 29	00 00 ~ 02 55	Send/read the AF level (00 00=Minimum ~ 02 55=Maximum)
	02 29	00 00 ~ 02 55	Send/read the RF gain level (00 00=Minimum ~ 02 55=Maximum)
	03 29	00 00 ~ 02 55	Send/read the squelch level (00 00=Minimum ~ 02 55=Maximum)
	05 29	00 00 ~ 02 55	Send/read the APF position (10 Hz steps) (00 00=Pitch-550 Hz, 01 28=Pitch, 02 55=Pitch+550 Hz)
	06 29	00 00 ~ 02 55	Send/read the NR level (00 00=0% ~ 02 55=100%)
	07 29	00 00 ~ 02 55	Send/read [TWIN PBT] (PBT1) position (00 00=max. Counter Clockwise ~ 01 28=center ~ 02 55=max. Clockwise)
	08 29	00 00 ~ 02 55	Send/read [TWIN PBT] (PBT2) position (00 00=max. Counter Clockwise ~ 01 28=center ~ 02 55=max. Clockwise)

REMOTE CONTROL

Remote control (CI-V) information

◇ Command table

Cmd.	Sub cmd.	Data	Description
14*	09	00 00 ~ 02 55	Send/read CW pitch (5 Hz steps) (00 00=300 Hz ~ 01 28=600 Hz ~ 02 55=900 Hz)
	0A	00 00 ~ 02 55	Send/read the selected band's RF power (00 00=Minimum ~ 02 55=Maximum)
	0B	00 00 ~ 02 55	Send/read MIC gain (00 00=Minimum ~ 02 55=Maximum)
	0C	00 00 ~ 02 55	Send/read keying speed (00 00=6 WPM ~ 02 55=48 WPM)
	0D 29	00 00 ~ 02 55	Send/read Notch filter setting (00 00=max. Counter Clockwise ~ 01 28=center ~ 02 55=max. Clockwise)
	0E	00 00 ~ 02 55	Send/read the COMP level (00 00=0 ~ 02 55=10)
	0F	00 00 ~ 02 55	Send/read the Break-IN Delay setting (00 00=2.0d ~ 02 55=13.0d)
	12 29	00 00 ~ 02 55	Send/read NB level (00 00=0% ~ 02 55=100%)
	13 29	00 00 ~ 02 55	Send/read the DIGI-SEL shift amount (00 00=min. ~ 02 55=max.)
	14	00 00 ~ 02 55	Send/read DRIVE Gain (00 00=0% ~ 02 55=100%)
	15	00 00 ~ 02 55	Send/read Monitor audio [MONI] level (00 00=0% ~ 02 55=100%)
	16	00 00 ~ 02 55	Send/read the VOX gain (00 00=0% ~ 02 55=100%)
	17	00 00 ~ 02 55	Send/read the Anti VOX gain (00 00=0% ~ 02 55=100%)
	19	00 00 ~ 02 55	Send/read LCD backlight brightness (00 00=0% ~ 02 55=100%)
15	01 29	00/01	Read noise or S-meter squelch status (00=Close, 01=Open)
	02 29	00 00 ~ 02 55	Read S-meter level (00 00=S0, 01 20=S9, 02 41=S9+60 dB)
	05 29	00/01	Read various squelch (tone squelch, and so on) status (00=Close, 01=Open)
	07 29	00/01	Read the OVF status (00=OVF indicator is OFF, 01=OVF indicator is ON)
	11	00 00 ~ 02 55	Read the Po meter level (00 00=0W ~ 01 43=100W ~ 02 12=200W)
	12	00 00 ~ 02 55	Read SWR meter level (00 00=SWR1.0, 00 48=SWR1.5, 00 80=SWR2.0, 01 20=SWR3.0)
	13	00 00 ~ 02 55	Read ALC meter level (00 00=Minimum ~ 01 20=Maximum)
	14	00 00 ~ 02 55	Read COMP meter level (00 00=0 dB ~ 01 30=15 dB ~ 02 41=30 dB)
	15	00 00 ~ 02 55	Read Vd meter level (00 00=0 V ~ 01 51=44 V ~ 02 11=52 V)
	16	00 00 ~ 02 55	Read Id meter level (00 00=0 A ~ 00 77=5 A ~ 01 65=10 A ~ 02 41=15 A)

Cmd.	Sub cmd.	Data	Description
16*	02 29	00	Preamp OFF
		01	Preamp 1 ON
		02	Preamp 2 ON
	12 29	01 ~ 03	Send/read the AGC time constant (01=FAST, 02=MID, 03=SLOW)
	22 29	00/01	Send/read the Noise blanker (00=OFF, 01=ON)
	32 29	00	Audio peak filter OFF
		01	Audio peak filter WIDE ON (320 Hz is selected when SHARP APF is set)
		02	Audio peak filter MID ON (160 Hz is selected when SHARP APF is set)
		03	Audio peak filter NAR ON (80 Hz is selected when SHARP APF is set)
		40 29	00/01
	41 29	00/01	Send/read the Auto Notch function (00=OFF, 01=ON)
	42 29	00/01	Send/read the Repeater tone (00=OFF, 01=ON)
	43 29	00/01	Send/read the Tone squelch (00=OFF, 01=ON)
	44	00/01	Send/read the Speech compressor (00=OFF, 01=ON)
	45	00/01	Send/read the Monitor [MONI] function (00=OFF, 01=ON)
	46	00/01	Send/read the VOX function (00=OFF, 01=ON)
	47	00	BK-IN function OFF
		01	Semi BK-IN function ON
		02	Full BK-IN function ON
	48 29	00/01	Send/read the Manual Notch function (00=OFF, 01=ON)
4E 29	00/01	Send/read the DIGI-SEL function (00=OFF, 01=ON)	
4F 29	00/01	Send/read the Twin peak filter (00=OFF, 01=ON) (Can be turned ON only when Mark and Shift are set to 2125 Hz and 170 Hz, respectively)	
50	00/01	Send/read the Dial Lock function (00=OFF, 01=ON) ① The main dial or panel display is locked, depending on the Lock Function (1A 05 00 77).	
53*3 29	00/01	Send/read the ANT-RX I/O (00=OFF, 01=ON)	
56 29	00/01	Send/read DSP IF filter type (00=SHARP, 01=SOFT)	
57 29	00 ~ 02	Send/read the Manual Notch width (00=WIDE, 01=MID, 02=NAR)	

REMOTE CONTROL

Remote control (CI-V) information

◇ Command table

Cmd.	Sub cmd.	Data	Description		
16*	58	00 ~ 02	Send/read SSB transmit bandwidth (00=WIDE, 01=MID, 02=NAR) (One of the following values is applied, depending on the "COMP" status (ON or OFF): WIDE (Command: 1A 05 00 15), MID (Command: 1A 05 00 16), or NAR (Command: 1A 05 00 17))		
			5E	00/01	MAIN/SUB Tracking function (00=OFF, 01=ON)
			65 29	00/01	Set the IP Plus function (00=OFF, 01=ON)
			66	00/01	Send/read the TX Inhibit function (00=OFF, 01=ON)
			67	00/01	Send/read the DPD function (00=OFF, 01=ON)
17*4		See p. 16.	Send CW messages		
18	00		Turn OFF the transceiver		
	01*5		Turn ON the transceiver		
19	00		Read the transceiver ID		
1A*	00	See p. 18.	Send/read memory contents		
	01	See p. 17.	Send/read band stacking register contents		
	02	See p. 19.	Send/read memory keyer contents		
	03 29	See p. 19.	Send/read the selected IF filter width		
	04 29	See p. 19.	Send/read the selected AGC time constant		
	05	SET > Tone Control/TBW			
	00 01	See p. 19.	RX > SSB > Send/read RX HPF/LPF settings		
	00 02	00 ~ 10	RX > SSB > Send/read RX Tone (Bass) level (00=-5 ~ 10=+5)		
	00 03	00 ~ 10	RX > SSB > Send/read RX Tone (Treble) level (00=-5 ~ 10=+5)		
	00 04	See p. 19.	RX > AM > Send/read RX HPF/LPF settings		
	00 05	00 ~ 10	RX > AM > Send/read RX Tone (Bass) level (00=-5 ~ 10=+5)		
	00 06	00 ~ 10	RX > AM > Send/read RX Tone (Treble) level (00=-5 ~ 10=+5)		
	00 07	See p. 19.	RX > FM > Send/read RX HPF/LPF settings		
00 08	00 ~ 10	RX > FM > Send/read RX Tone (Bass) level (00=-5 ~ 10=+5)			
00 09	00 ~ 10	RX > FM > Send/read RX Tone (Treble) level (00=-5 ~ 10=+5)			
00 10	See p. 19.	RX > CW > Send/read RX HPF/LPF settings			
00 11	See p. 19.	RX > RTTY > Send/read RX HPF/LPF settings			
00 12	See p. 19.	RX > PSK > Send/read RX HPF/LPF settings			

Cmd.	Sub cmd.	Data	Description		
1A*	05	00 13	00 ~ 10	TX > SSB > Send/read TX Tone (Bass) level (00=-5 ~ 10=+5)	
		00 14	00 ~ 10	TX > SSB > Send/read TX Tone (Treble) level (00=-5 ~ 10=+5)	
		00 15	See p. 19.	TX > SSB > Send/read TX bandwidth for wide	
		00 16	See p. 19.	TX > SSB > Send/read TX bandwidth for mid	
		00 17	See p. 19.	TX > SSB > Send/read TX bandwidth for narrow	
		00 18	See p. 19.	TX > SSB-D > Send/read TX bandwidth	
		00 19	00 ~ 10	TX > AM > Send/read TX Tone (Bass) level (00=-5 ~ 10=+5)	
		00 20	00 ~ 10	TX > AM > Send/read TX Tone (Treble) level (00=-5 ~ 10=+5)	
		00 21	00 ~ 10	TX > FM > Send/read TX Tone (Bass) level (00=-5 ~ 10=+5)	
		00 22	00 ~ 10	TX > FM > Send/read TX Tone (Treble) level (00=-5 ~ 10=+5)	
		SET > Function			
		00 23	00 00 ~ 02 55	Send/read the Beep Level setting (00 00=Minimum ~ 02 55=Maximum)	
		00 24	00/01	Send/read the Beep Level Limit setting (00=OFF, 01=ON)	
		00 25	00/01	Send/read the Beep (Confirmation) setting (00=OFF, 01=ON)	
		00 26	00 ~ 03	Send/read the Band Edge Beep setting (00=OFF, 01=ON (Default), 02=ON (User), 03=ON (User) & TX Limit)	
		00 27	00 50 ~ 02 00	Function > Beep Sound (MAIN) (00 50=500 Hz ~ 02 00=2000 Hz)	
		00 28	00 50 ~ 02 00	Function > Beep Sound (SUB) (00 50=500 Hz ~ 02 00=2000 Hz)	
		00 29	00/01	Send/read the Speaker MAIN/SUB Mix (00=OFF, 01=ON)	
		00 30	00 ~ 02	RF/SQL Control (00=Auto, 01=SQL, 02=RF+SQL)	
		00 31	00/01	Send/read the Cancel CI-V Remote Set Levels (00=All Volume Levels, 01=Operated Volume Level)	
		00 32	00 02 ~ 02 00	TX Power Limit > 1.8M (00 02=2 W ~ 02 00=200 W)	
		00 33	00 02 ~ 02 00	TX Power Limit > 1.8M (DATA) (00 02=2 W ~ 02 00=200 W)	
00 34	00 02 ~ 02 00	TX Power Limit > 3.5M (00 02=2 W ~ 02 00=200 W)			
00 35	00 02 ~ 02 00	TX Power Limit > 3.5M (DATA) (00 02=2 W ~ 02 00=200 W)			

REMOTE CONTROL

Remote control (CI-V) information

◇ Command table

Cmd.	Sub cmd.	Data	Description
1A*	05	SET > Function	
	00 36	00 02 ~ 02 00	TX Power Limit > 5M (00 02=2 W ~ 02 00=200 W)
	00 37	00 02 ~ 02 00	TX Power Limit > 5M (DATA) (00 02=2 W ~ 02 00=200 W)
	00 38	00 02 ~ 02 00	TX Power Limit > 7M (00 02=2 W ~ 02 00=200 W)
	00 39	00 02 ~ 02 00	TX Power Limit > 7M (DATA) (00 02=2 W ~ 02 00=200 W)
	00 40	00 02 ~ 02 00	TX Power Limit > 10M (00 02=2 W ~ 02 00=200 W)
	00 41	00 02 ~ 02 00	TX Power Limit > 10M (DATA) (00 02=2 W ~ 02 00=200 W)
	00 42	00 02 ~ 02 00	TX Power Limit > 14M (00 02=2 W ~ 02 00=200 W)
	00 43	00 02 ~ 02 00	TX Power Limit > 14M (DATA) (00 02=2 W ~ 02 00=200 W)
	00 44	00 02 ~ 02 00	TX Power Limit > 18M (00 02=2 W ~ 02 00=200 W)
	00 45	00 02 ~ 02 00	TX Power Limit > 18M (DATA) (00 02=2 W ~ 02 00=200 W)
	00 46	00 02 ~ 02 00	TX Power Limit > 21M (00 02=2 W ~ 02 00=200 W)
	00 47	00 02 ~ 02 00	TX Power Limit > 21M (DATA) (00 02=2 W ~ 02 00=200 W)
	00 48	00 02 ~ 02 00	TX Power Limit > 24M (00 02=2 W ~ 02 00=200 W)
	00 49	00 02 ~ 02 00	TX Power Limit > 24M (DATA) (00 02=2 W ~ 02 00=200 W)
	00 50	00 02 ~ 02 00	TX Power Limit > 28M (00 02=2 W ~ 02 00=200 W)
	00 51	00 02 ~ 02 00	TX Power Limit > 28M (DATA) (00 02=2 W ~ 02 00=200 W)
	00 52	00 02 ~ 02 00	TX Power Limit > 50M (00 02=2 W ~ 02 00=200 W)
	00 53	00 02 ~ 02 00	TX Power Limit > 50M (DATA) (00 02=2 W ~ 02 00=200 W)
	00 54	00 ~ 05	TX Delay > HF (00=OFF, 01=10 ms, 02=15 ms, 03=20 ms, 04=25 ms, 05=30 ms)
	00 55	00 ~ 05	TX Delay > 50M (00=OFF, 01=10 ms, 02=15 ms, 03=20 ms, 04=25 ms, 05=30 ms)
	00 56	00 ~ 05	Send/read the Time-Out Timer (CI-V) setting (00=OFF, 01=3 min, 02=5 min, 03=10 min, 04=20 min, 05=30 min)
	00 57	00/01	Send/read the Quick Dualwatch (00=OFF, 01=ON)
	00 58	00/01	SPLIT > Send/read the Quick SPLIT setting (00=OFF, 01=ON)
	00 59	00/01	SPLIT > Display Keypad on Quick SPLIT (00=OFF, 01=ON)
	00 60	See p. 20.	SPLIT > FM SPLIT Offset (HF)
	00 61	See p. 20.	SPLIT > FM SPLIT Offset (50M)

Cmd.	Sub cmd.	Data	Description	
1A*	05	00 62	00/01	SPLIT > Send/read the SPLIT LOCK setting (00=OFF, 01=ON)
		00 63	00/01	Tuner > Send/read the PTT Start setting (00=OFF, 01=ON)
		00 64	00/01	Send/read the Transverter Function setting (00=Auto, 01=ON)
		00 65	See p. 20.	Send/read the Transverter Offset setting
		00 66	00/01	Send/read the IC-PW2 Dual Connection Mode setting (00=OFF, 01=ON)
		00 67	00 ~ 02	Send/read the RTTY Mark Frequency setting (00=1275 Hz, 01=1615 Hz, 02=2125 Hz)
		00 68	00 ~ 02	Send/read the RTTY Shift Width setting (00=170 Hz, 01=200 Hz, 02=425 Hz)
		00 69	00/01	Send/read the RTTY Keying Polarity setting (00=Normal, 01=Reverse)
		00 70	00 ~ 02	Send/read the PSK Tone Frequency setting (00=1000 Hz, 01=1500 Hz, 02=2000 Hz)
		00 71	00/01	SPEECH > Send/read the SPEECH Language setting (00=English, 01=Japanese)
		00 72	00/01	SPEECH > Send/read the SPEECH Speed setting (00=Slow, 01=Fast)
		00 73	00/01	SPEECH > Send/read the S-Level SPEECH setting (00=OFF, 01=ON)
		00 74	00/01	SPEECH > Send/read the MODE SPEECH setting (00=OFF, 01=ON)
		00 75	00 00 ~ 02 55	SPEECH > Send/read the SPEECH Level setting (00 00=0% ~ 02 55=100%)
		00 76	00/01	Send/read the [SPEECH/LOCK] Switch setting (00=SPEECH/LOCK, 01=LOCK/SPEECH)
		00 77	00/01	Send/read the Lock Function setting (00=MAIN DIAL, 01=PANEL)
		00 78	00/01	Send/read the Memo Pad Quantity setting (00=5 ch, 01=10 ch)
		00 79	00 ~ 02	Send/read the MAIN DIAL Auto TS setting (00=OFF, 01=Low, 02=High)
		00 80	00/01	Send/read the MAIN DIAL Select (USB DIAL-SUB Only) setting (00=Main only, 01=Main/Sub)

REMOTE CONTROL

Remote control (CI-V) information

◇ Command table

Cmd.	Sub cmd.	Data	Description	
1A*	05	SET > Function		
		00 81	00/01 Send/read the MIC Up/Down Speed setting (00=LOW, 01=HIGH)	
		00 82	00/01 Send/read the Quick RIT/ Δ TX Clear setting (00=OFF, 01=ON)	
		00 83	00 ~ 02 Send/read the [NOTCH] Switch (SSB) setting (00=Auto, 01=Manual, 02=Auto/Manual)	
		00 84	00 ~ 02 Send/read the [NOTCH] Switch (AM) setting (00=Auto, 01=Manual, 02=Auto/Manual)	
		00 85	00/01 Send/read the FILTER Screen MAIN/SUB Select setting (00=Fix, 01=Auto (by FILTER, PBT Operation))	
		00 86	00/01 Send/read the SSB/CW Synchronous Tuning setting (00=OFF, 01=ON)	
		00 87	00/01 Send/read the CW Normal Side setting (00=LSB, 01=USB)	
		SET > Function > Front Key Customize		
		00 88	See p. 20. Send/read the [VOX/BK-IN] Key setting	
		00 89	See p. 20. Send/read the [AUTOTUNE] Key setting	
		SET > Function > MIC Key Customize		
		00 90	See p. 20. Send/read the [UP] Key setting	
		00 91	See p. 20. Send/read the [DN] Key setting	
		SET > Function		
		00 92	00/01 Send/read the Screen Keyboard Type setting (00=Ten-key, 01=Full Keyboard)	
		00 93	00 ~ 02 Send/read the Screen Full Keyboard Layout setting (00=English, 01=German, 02=French)	
		00 94	00/01 Send/read the Screen Capture [POWER] Switch setting (00=OFF, 01=ON)	
		00 95	00/01 Send/read the Screen Capture Keyboard [Print Screen] setting (00=OFF, 01=ON)	
		00 96	00/01 Send/read the Screen Capture Storage Media setting (00=SD Card, 01=USB flash drive)	
		00 97	00/01 Send/read the Screen Capture File Type setting (00=PNG, 01=BMP)	
		00 98	00/01 Send/read the Calibration Marker setting (00=OFF, 01=ON)	
		00 99	00 00 ~ 05 11 Send/read the REF Adjust setting (00 00=0%, 05 11=100%)	
		SET > Connectors		
		01 00	00 ~ 30 Phones > Send/read the Level setting (00=-15 dB ~ 30=+15 dB)	

Cmd.	Sub cmd.	Data	Description
1A*	05	01 01	00/01 Phones > Send/read the L/R Mix setting (00=OFF, 01=ON)
		01 02	00 00 ~ 02 55 Phones > Send/read the Phone L/R Mix Level setting (00 00=0% ~ 02 55=100%)
		01 03	00/01 USB AF/IF Output > Send/read the Output Select setting (00=AF, 01=IF)
		01 04	00/01 USB AF/IF Output > Send/read the AF/IF XFC Output (SPLIT ON) setting (00=MAIN, 01=SUB)
		01 05	00 00 ~ 02 55 USB AF/IF Output > Send/read the AF Output Level setting (00 00=0% ~ 02 55=100%)
		01 06	00/01 USB AF/IF Output > Send/read the AF SQL setting (00=OFF (Open), 01=ON)
		01 07	00/01 USB AF/IF Output > Send/read the AF Beep/Speech... Output setting (00=OFF, 01=ON)
		01 08	00 00 ~ 02 55 USB AF/IF Output > Send/read the IF Output Level setting (00 00=0% ~ 02 55=100%)
		01 09	00/01 LINE-OUT AF/IF Output > Send/read the AF Output Select setting (00=MAIN, 01=SUB)
		01 10	00/01 LINE-OUT AF/IF Output > Send/read the Output Select setting (00=AF, 01=IF)
		01 11	00/01 LINE-OUT AF/IF Output > Send/read the AF/IF XFC Output (SPLIT ON) setting (00=MAIN, 01=SUB)
		01 12	00 00 ~ 02 55 LINE-OUT AF/IF Output > Send/read the AF Output Level setting (00 00=0% ~ 02 55=100%)
		01 13	00/01 LINE-OUT AF/IF Output > Send/read the AF SQL setting (00=OFF (Open), 01=ON)
		01 14	00/01 LINE-OUT AF/IF Output > Send/read the AF Beep/Speech... Output setting (00=OFF, 01=ON)
		01 15	00 00 ~ 02 55 LINE-OUT AF/IF Output > Send/read the IF Output Level setting (00 00=0% ~ 02 55=100%)
		01 16	00/01 ACC AF/IF Output > Send/read the AF/SQL Output Select setting (00=MAIN, 01=SUB)
		01 17	00/01 ACC AF/IF Output > Send/read the Output Select setting (00=AF, 01=IF)
		01 18	00/01 ACC AF/IF Output > Send/read the AF/IF XFC Output (SPLIT ON) setting (00=MAIN, 01=SUB)

REMOTE CONTROL

Remote control (CI-V) information

◇ Command table

Cmd.	Sub cmd.	Data	Description
1A*	05	SET > Connectors	
	01 19	00 00 ~ 02 55	ACC AF/IF Output > Send/read the AF Output Level setting (00 00=0% ~ 02 55=100%)
	01 20	00/01	ACC AF/IF Output > Send/read the AF SQL setting (00=OFF (Open), 01=ON)
	01 21	00/01	ACC AF/IF Output > Send/read the AF Beep/Speech... Output setting (00=OFF, 01=ON)
	01 22	00 00 ~ 02 55	ACC AF/IF Output > Send/read the IF Output Level setting (00 00=0% ~ 02 55=100%)
	01 23	00/01	LAN AF/IF Output > Send/read the Output Select setting (00=AF, 01=IF)
	01 24	00/01	LAN AF/IF Output > Send/read the AF SQL setting (00=OFF (Open), 01=ON)
	01 25	00 00 ~ 02 55	MOD Input > Send/read the USB MOD Level setting (00 00=0% ~ 02 55=100%)
	01 26	00 00 ~ 02 55	MOD Input > Send/read the LINE-IN MOD Level setting (00 00=0% ~ 02 55=100%)
	01 27	00 00 ~ 02 55	MOD Input > Send/read the ACC MOD Level setting (00 00=0% ~ 02 55=100%)
	01 28	00 00 ~ 02 55	MOD Input > Send/read the LAN MOD Level setting (00 00=0% ~ 02 55=100%)
	01 29	00 ~ 09	MOD Input > Send/read the DATA OFF MOD setting (00=MIC, 01=USB, 02=LINE-IN, 03=ACC, 04=MIC, USB, 05=MIC, LINE-IN, 06=MIC, ACC, 07=MIC, USB, ACC, 08=MIC, LINE-IN, ACC, 09=LAN)
	01 30	00 ~ 09	MOD Input > Send/read the DATA1 MOD setting (00=MIC, 01=USB, 02=LINE-IN, 03=ACC, 04=MIC, USB, 05=MIC, LINE-IN, 06=MIC, ACC, 07=MIC, USB, ACC, 08=MIC, LINE-IN, ACC, 09=LAN)
	01 31	00 ~ 09	MOD Input > Send/read the DATA2 MOD setting (00=MIC, 01=USB, 02=LINE-IN, 03=ACC, 04=MIC, USB, 05=MIC, LINE-IN, 06=MIC, ACC, 07=MIC, USB, ACC, 08=MIC, LINE-IN, ACC, 09=LAN)
	01 32	00 ~ 09	MOD Input > Send/read the DATA3 MOD setting (00=MIC, 01=USB, 02=LINE-IN, 03=ACC, 04=MIC, USB, 05=MIC, LINE-IN, 06=MIC, ACC, 07=MIC, USB, ACC, 08=MIC, LINE-IN, ACC, 09=LAN)

Cmd.	Sub cmd.	Data	Description
1A*	05 01 33	00 ~ 04	USB SEND/Keying > Send/read the USB SEND setting (00=OFF, 01=USB (A) DTR, 02=USB (A) RTS, 03=USB (B) DTR, 04=USB (B) RTS) ① USB (A) and USB (B) are the 2 virtual COM ports on the [USB B] port on the controller's rear panel. ② You cannot select the same setting for USB keying (CW) or USB keying (RTTY).
	01 34	00 ~ 04	USB SEND/Keying > Send/read the USB Keying (CW) setting (00=OFF, 01=USB (A) DTR, 02=USB (A) RTS, 03=USB (B) DTR, 04=USB (B) RTS) ① USB (A) and USB (B) are the 2 virtual COM ports on the [USB B] port on the controller's rear panel. ② You cannot select the same setting for USB SEND.
	01 35	00 ~ 04	USB SEND/Keying > Send/read the USB Keying (RTTY) setting (00=OFF, 01=USB (A) DTR, 02=USB (A) RTS, 03=USB (B) DTR, 04=USB (B) RTS) ① USB (A) and USB (B) are the 2 virtual COM ports on the [USB B] port on the controller's rear panel. ② You cannot select the same setting for USB SEND.
	01 36	00/01	External Keypad > Send/read the VOICE setting (00=OFF, 01=ON)
	01 37	00/01	External Keypad > Send/read the KEYSER setting (00=OFF, 01=ON)
	01 38	00/01	External Keypad > Send/read the RTTY setting (00=OFF, 01=ON)
	01 39	00/01	External Keypad > Send/read the PSK setting (00=OFF, 01=ON)
	01 40	00/01	Keyboard/Mouse > Send/read the Keyboard [F1]-[F8] (VOICE) setting (00=OFF, 01=ON)
	01 41	00/01	Keyboard/Mouse > Send/read the Keyboard [F1]-[F8] (KEYER) setting (00=OFF, 01=ON)
	01 42	00 ~ 10	Keyboard/Mouse > Send/read the Keyboard Type setting (00=English, 01=Japanese, 02=United Kingdom, 03=French, 04=French (Canadian), 05=German, 06=Portuguese, 07=Portuguese (Brazilian), 08=Spanish, 09=Spanish (Latin American), 10=Italian)

REMOTE CONTROL

Remote control (CI-V) information

◇ Command table

Cmd.	Sub cmd.	Data	Description
1A*	05	SET > Connectors	
	01 43	00 10 ~ 01 00	Keyboard/Mouse > Send/read the Keyboard Repeat Delay setting (00 10=100 msec. ~ 01 00=1000 msec. (in 50 msec. steps))
	01 44	00 ~ 31	Keyboard/Mouse > Send/read the Keyboard Repeat Rate setting (00=2.0 cps ~ 31=30.0 cps)
	01 45	00 ~ 02	Keyboard/Mouse > Send/read the Mouse Pointer Speed setting (00=Slow, 01=Mid, 02=Fast)
	01 46	00/01	Keyboard/Mouse > Send/read the Mouse Pointer Acceleration setting (00=OFF, 01=ON)
	01 47	00/01	USB DIAL > Send/read the USB DIAL Select setting (00=Only Sub, 01=Main/Sub)
	01 48	00 ~ 02	USB DIAL > Send/read the USB DIAL Auto TS setting (00=OFF, 01=Low, 02=High)
	01 49	00/01	USB DIAL > Send/read the USB DIAL [TRANSMIT] Switch setting (00=Push to toggle, 01=Hold down to transmit)
	01 50	00/01	CI-V > Send/read the CI-V Transceive Switch setting (00=OFF, 01=ON)
	01 51	00 00 ~ 02 23	CI-V > Send/read the CI-V USB/LAN→REMOTE Transceive Address setting (00 00=00h ~ 02 23=DFh) (in Hexadecimal)
	01 52	00/01	CI-V > Send/read the CI-V Output (for ANT) setting (00=OFF, 01=ON)
	01 53	00/01	CI-V > Send/read the CI-V USB (A) Echo Back setting (00=OFF, 01=ON)
	01 54	00/01	CI-V > Send/read the CI-V USB (B) Echo Back setting (00=OFF, 01=ON)
	01 55	00/01	CI-V > Send/read the USB (B) Function setting (00=RTTY/PSK Decode, 01=CI-V)
	01 56	00/01	Send/read the SEND Relay Type setting (00=Reed, 01=MOS-FET)
01 57	00 ~ 02	Send/read the ACC BAND Voltage Output setting (00=MAIN, 01=SUB, 02=TX)	

Cmd.	Sub cmd.	Data	Description	
1A*	05	01 58	00/01	Send/read the MIC Input DC Bias setting (00=OFF, 01=ON)
		01 59	00/01	Send/read the PTT Port Function setting (00=PTT Input, 01=PTT Input + SEND Output)
		01 60	00/01	Send/read the REF IN setting (00=IN, 01=OFF)
	SET > Network			
	01 61	00/01	00/01	Send/read the DHCP (valid after restart) setting (00=OFF, 01=ON)
	01 62	See p. 20.		Send/read the IP Address (LAN) (valid after restart) setting ① Valid when the DHCP (valid after restart) is set to OFF. ① You cannot set the same address as "IP Address (Controller)," "IP Address (RF Deck)," and "Default Gateway."
	01 63*1	See p. 20.		Read the IP address obtained through the DHCP (valid after restart) setting. ① When the DHCP (valid after restart) is set to OFF, the manually set IP address (LAN) is returned.
	01 64	See p. 20.		Send/read the IP Address (Controller) (valid after restart) setting ① Valid when the DHCP (valid after restart) is set to OFF. ① You cannot set the same address as "IP Address (LAN)," "IP Address (RF Deck)," and "Default Gateway."
	01 65	See p. 20.		Send/read the IP Address (RF Deck) (valid after restart) setting ① Valid when the DHCP (valid after restart) is set to OFF. ① You cannot set the same address as "IP Address (LAN)," "IP Address (Controller)," and "Default Gateway." ① When the RF deck and the controller are connected between different segments, set the address to 1A 05 01 72.
	01 66	01 ~ 30		Send/read the Subnet Mask (valid after restart) setting (01=128.0.0.0 (1 bit) ~ 30=255.255.255.252 (30 bit)) ① Valid when the DHCP (valid after restart) is set to OFF.
	01 67	See p. 20.		Send/read the Default Gateway (valid after restart) setting ① Valid when the DHCP (valid after restart) is set to OFF. ① You cannot set the same address as "IP Address (LAN)." ① When the RF deck and the controller are connected between different segments, set the address to 1A 05 01 74.

REMOTE CONTROL

Remote control (CI-V) information

◇ Command table

Cmd.	Sub cmd.	Data	Description	
1A*	05	SET > Network		
	01 68	See p. 20.	Send/read the Primary DNS Server (valid after restart) setting ① Valid when the DHCP (valid after restart) is set to OFF.	
	01 69	See p. 20.	Send/read the Secondary DNS Server (valid after restart) setting ① Valid when the DHCP (valid after restart) is set to OFF.	
	01 70	00 ~ 02	Send/read the Audio Buffer Size (via LAN) (valid after restart) setting (00=Small, 01=Mid, 02=Large) ① Valid when the controller and RF deck are connected through a network.	
	01 71	00/01	Send/read the Connection from Different Segment (valid after restart) setting (00=OFF, 01=ON)	
	SET > Network > Different Segment Settings			
	01 72	See p. 20.	Send/read the IP Address (RF Deck) (valid after restart) setting ① Valid when the Connection from Different Segment (valid after restart) is set to ON.	
	01 73	01 ~ 30	Send/read the Subnet Mask (RF Deck) (valid after restart) setting (01=128.0.0.0 (1 bit) ~ 30=255.255.255.252 (30 bit)) ① Valid when the Connection from Different Segment (valid after restart) is set to ON.	
	01 74	See p. 20.	Send/read the Default Gateway (RF Deck) (valid after restart) setting ① Valid when the Connection from Different Segment (valid after restart) is set to ON. ① You cannot set the same address as "IP Address (RF Deck)."	
	01 75	00 ~ 02	Send/read the Audio Buffer Size (valid after restart) setting (00=Small, 01=Mid, 02=Large) ① Valid when the RF deck and the controller are connected between different segments.	
	SET > Network			
	01 76	See p. 18.	Send/read the Network Name (valid after restart) setting (Up to 15 characters)	
	SET > Network > Remote Settings			
	01 77	00/01	Send/read the Network Control (valid after restart) setting (00=OFF, 01=ON)	
	01 78	00/01	Send/read the Shutdown Function setting (00=Only Shutdown, 01=Standby/Shutdown)	
	01 79	00 00 01 ~ 06 55 35	Send/read the Control Port (UDP) (valid after restart) setting (00 00 01=1 ~ 06 55 35=65535)	

Cmd.	Sub cmd.	Data	Description	
1A*	05	01 80	00 00 01 ~ 06 55 35 Send/read the Serial Port (UDP) (valid after restart) setting (00 00 01=1 ~ 06 55 35=65535)	
		01 81	00 00 01 ~ 06 55 35 Send/read the Audio Port (UDP) (valid after restart) setting (00 00 01=1 ~ 06 55 35=65535)	
		01 82	00/01 Send/read the Internet Access Line (valid after restart) setting (00=FTTH (Fiber To The Home), 01=ADSL/CATV)	
		01 83	See p. 18. Send/read the Network Radio Name setting (Up to 16 characters)	
	SET > Display			
		01 84	00 00 ~ 02 55 Send/read the LCD Backlight setting (00 00=0% ~ 02 55=100%)	
		01 85	00 00 ~ 02 55 Send/read the LED Bright setting (00 00=0% ~ 02 55=100%)	
		01 86	00/01 Send/read the Display Font setting (00=Square, 01=Round)	
		01 87	00 ~ 02 Send/read the Meter Response (Standard, Edgewise) setting (00=Slow, 01=Mid, 02=Fast)	
		01 88	00 ~ 02 Send/read the Meter Type (Normal Screen) setting (00=Standard, 01=Edgewise, 02=Bar)	
		01 89	00/01 Send/read the Meter Type (Expand Screen) setting (00=Edgewise, 01=Bar)	
		01 90	00/01 Send/read the Meter Peak Hold (Bar) setting (00=OFF, 01=ON)	
		01 91	00/01 Send/read the Memory Name setting (00=OFF, 01=ON)	
	SET > Display > Filter Effect Screen			
		01 92	00/01 Send/read the Waveform Type setting (00=Line, 01=Fill)	
		01 93	See p. 21. Send/read the Waveform Color setting	
	SET > Display			
		01 94	00 ~ 03 Send/read the Screen Saver setting (00=OFF, 01=15 minutes, 02=30 minutes, 03=60 minutes)	
		01 95	00/01 Send/read the External Display setting (00=OFF, 01=ON)	
	01 96	00/01 Send/read the External Display Resolution setting (00=800x480, 01=800x600)		
	01 97	00/01 Send/read the Opening Message setting (00=OFF, 01=ON)		
	01 98	See p. 18. Send/read the My Call setting (Up to 10 characters)		
	01 99	00/01 Send/read the Display Language setting (00=English, 01=Japanese)		

REMOTE CONTROL

Remote control (CI-V) information

◇ Command table

Cmd.	Sub cmd.	Data	Description	
1A*	05	SET > Time Set		
	02 00	20 20 01 01 ~ 20 99 12 31	Date/Time > Send/read the Date setting (20 20 01 01=2020/01/01 ~ 20 99 12 31=2099/12/31)	
	02 01	00 00 ~ 23 59	Date/Time > Send/read the Time setting (00 00=00:00 ~ 23 59=23:59)	
	02 02	00/01	Date/Time > Send/read the NTP Function setting (00=OFF, 01=ON)	
	02 03	See p. 18.	Date/Time > Send/read the NTP Server Address setting (Up to 64 characters)	
	02 04	See p. 21.	Send/read the UTC Offset setting	
	02 05	00/01	Send/read the CLOCK2 Function setting (00=OFF, 01=ON)	
	02 06	See p. 21.	Send/read the CLOCK2 UTC Offset setting	
	02 07	See p. 18.	Send/read the CLOCK2 Name setting (Up to 3 characters)	
	SCOPE SET: SCOPE > EXPD/SET (Touch for 1 second)			
	02 08	00/01	Send/read the Scope during Tx (CENTER Type) setting (00=OFF, 01=ON)	
	02 09	00 ~ 02	Send/read the Max Hold setting (00=OFF, 01=10s Hold, 02=ON)	
	02 10	00 ~ 02	Send/read the CENTER Type Display setting (00=Filter center, 01=Carrier point center, 02=Carrier point center (Abs. Freq.))	
	02 11	00/01	Send/read the Marker Position (Fix Type/ SCROLL Type) setting (00=Filter center, 01 Carrier point)	
	02 12	00 ~ 02	Send/read the Averaging setting (00=OFF, 01=2, 02=3, 03=4)	
	02 13	00/01	Send/read the Waveform Type setting (00=Fill, 01=Fill+Line)	
	02 14	See p. 21.	Send/read the Waveform Color (Current) setting	
	02 15	See p. 21.	Send/read the Waveform Color (Line) setting	
	02 16	See p. 21.	Send/read the Waveform Color (Max Hold) setting	
	02 17	00/01	Send/read the Waterfall Display setting (00=OFF, 01=ON)	
	02 18	00 ~ 02	Send/read the Waterfall Speed setting (00=Slow, 01=Mid, 02=Fast)	
02 19	00 ~ 02	Send/read the Waterfall Size (Expand Screen) setting (00=Small, 01=Mid, 02=Large)		
02 20	00 ~ 09	Send/read the Waterfall Peak Color Level setting (00=Grid 1 ~ 09=Grid 10)		
02 21	00/01	Send/read the Waterfall Marker Auto-hide setting (00=OFF, 01=ON)		

Cmd.	Sub cmd.	Data	Description	
1A*	05	02 22	00/01	Send/read the Dual Scope Type setting (00=Over/Under, 01=Side by Side)
		02 23	00/01	Send/read the Dual Scope Auto Select setting (00=OFF, 01=ON)
	SCOPE > EXPD/SET (Touch for 1 second) > Fixed Edges			
		02 24	See p. 21.	0.03 – 1.60 > Send/read the No.1 setting
		02 25	See p. 21.	0.03 – 1.60 > Send/read the No.2 setting
		02 26	See p. 21.	0.03 – 1.60 > Send/read the No.3 setting
		02 27	See p. 21.	0.03 – 1.60 > Send/read the No.4 setting
		02 28	See p. 21.	1.60 – 2.00 > Send/read the No.1 setting
		02 29	See p. 21.	1.60 – 2.00 > Send/read the No.2 setting
		02 30	See p. 21.	1.60 – 2.00 > Send/read the No.3 setting
		02 31	See p. 21.	1.60 – 2.00 > Send/read the No.4 setting
		02 32	See p. 21.	2.00 – 6.00 > Send/read the No.1 setting
		02 33	See p. 21.	2.00 – 6.00 > Send/read the No.2 setting
		02 34	See p. 21.	2.00 – 6.00 > Send/read the No.3 setting
		02 35	See p. 21.	2.00 – 6.00 > Send/read the No.4 setting
		02 36	See p. 21.	6.00 – 8.00 > Send/read the No.1 setting
		02 37	See p. 21.	6.00 – 8.00 > Send/read the No.2 setting
		02 38	See p. 21.	6.00 – 8.00 > Send/read the No.3 setting
		02 39	See p. 21.	6.00 – 8.00 > Send/read the No.4 setting
		02 40	See p. 21.	8.00 – 11.00 > Send/read the No.1 setting
		02 41	See p. 21.	8.00 – 11.00 > Send/read the No.2 setting
		02 42	See p. 21.	8.00 – 11.00 > Send/read the No.3 setting
		02 43	See p. 21.	8.00 – 11.00 > Send/read the No.4 setting
		02 44	See p. 21.	11.00 – 15.00 > Send/read the No.1 setting
		02 45	See p. 21.	11.00 – 15.00 > Send/read the No.2 setting
		02 46	See p. 21.	11.00 – 15.00 > Send/read the No.3 setting
		02 47	See p. 21.	11.00 – 15.00 > Send/read the No.4 setting
		02 48	See p. 21.	15.00 – 20.00 > Send/read the No.1 setting
		02 49	See p. 21.	15.00 – 20.00 > Send/read the No.2 setting

REMOTE CONTROL

Remote control (CI-V) information

◇ Command table

Cmd.	Sub cmd.	Data	Description		
1A*	05	SCOPE > EXPD/SET (Touch for 1 second) > Fixed Edges			
		02 50	See p. 21. 15.00 – 20.00 > Send/read the No.3 setting		
		02 51	See p. 21. 15.00 – 20.00 > Send/read the No.4 setting		
		02 52	See p. 21. 20.00 – 22.00 > Send/read the No.1 setting		
		02 53	See p. 21. 20.00 – 22.00 > Send/read the No.2 setting		
		02 54	See p. 21. 20.00 – 22.00 > Send/read the No.3 setting		
		02 55	See p. 21. 20.00 – 22.00 > Send/read the No.4 setting		
		02 56	See p. 21. 22.00 – 26.00 > Send/read the No.1 setting		
		02 57	See p. 21. 22.00 – 26.00 > Send/read the No.2 setting		
		02 58	See p. 21. 22.00 – 26.00 > Send/read the No.3 setting		
		02 59	See p. 21. 22.00 – 26.00 > Send/read the No.4 setting		
		02 60	See p. 21. 26.00 – 30.00 > Send/read the No.1 setting		
		02 61	See p. 21. 26.00 – 30.00 > Send/read the No.2 setting		
		02 62	See p. 21. 26.00 – 30.00 > Send/read the No.3 setting		
		02 63	See p. 21. 26.00 – 30.00 > Send/read the No.4 setting		
		02 64	See p. 21. 30.00 – 45.00 > Send/read the No.1 setting		
		02 65	See p. 21. 30.00 – 45.00 > Send/read the No.2 setting		
		02 66	See p. 21. 30.00 – 45.00 > Send/read the No.3 setting		
		02 67	See p. 21. 30.00 – 45.00 > Send/read the No.4 setting		
		02 68	See p. 21. 45.00 – 60.00 > Send/read the No.1 setting		
		02 69	See p. 21. 45.00 – 60.00 > Send/read the No.2 setting		
		02 70	See p. 21. 45.00 – 60.00 > Send/read the No.3 setting		
		02 71	See p. 21. 45.00 – 60.00 > Send/read the No.4 setting		
		AUDIO SCOPE SET: AUDIO > SET			
		02 72	00/01	Send/read the FFT Scope Waveform Type setting (00=Line, 01=Fill)	
		02 73	See p. 21.	Send/read the FFT Scope Waveform Color setting	
		02 74	00/01	Send/read the FFT Scope Waterfall Display setting (00=OFF, 01=ON)	
		02 75	See p. 21.	Send/read the Oscilloscope Waveform Color setting	

Cmd.	Sub cmd.	Data	Description		
1A*	05	KEYER 001: KEYER > EDIT/SET > 001 SET			
		02 76	00 ~ 04 Send/read the Number Style setting (00=Normal, 01=190→ANO, 02=190→ANT, 03=90→NO, 04=90→NT)		
		02 77	00/01 Send/read the Count Up Trigger (M1) setting (00=OFF, 01=ON)		
		02 78	00/01 Send/read the Count Up Trigger (M2) setting (00=OFF, 01=ON)		
		02 79	00/01 Send/read the Count Up Trigger (M3) setting (00=OFF, 01=ON)		
		02 80	00/01 Send/read the Count Up Trigger (M4) setting (00=OFF, 01=ON)		
		02 81	00/01 Send/read the Count Up Trigger (M5) setting (00=OFF, 01=ON)		
		02 82	00/01 Send/read the Count Up Trigger (M6) setting (00=OFF, 01=ON)		
		02 83	00/01 Send/read the Count Up Trigger (M7) setting (00=OFF, 01=ON)		
		02 84	00/01 Send/read the Count Up Trigger (M8) setting (00=OFF, 01=ON)		
		02 85	00 01 ~ 99 99 Send/read the Present Number setting (00 01=1 ~ 99 99=9999)		
		SET > CW-KEY Set			
		02 86	00 00 ~ 02 55	Send/read the Side Tone Level setting (00 00=0% ~ 02 55=100%)	
		02 87	00/01	Send/read the Side Tone Level Limit setting (00=OFF, 01=ON)	
		02 88	01 ~ 60	Send/read the Keyer Repeat time setting (01=1 sec. ~ 60=60 sec.)	
		02 89	28 ~ 45	Send/read the Dot/Dash Ratio setting (28=1:1:2.8 ~ 45=1:1:4.5; 0.1 steps)	
		02 90	00 ~ 03	Send/read the Rise Time setting (00=2 msec., 01=4 msec., 02=6 msec., 03=8 msec.)	
		02 91	00/01	Send/read the Paddle Polarity setting (00=Normal, 01=Reverse)	
		02 92	00 ~ 02	Send/read the Key Type setting (00=Straight, 01=Bug, 02=Paddle)	
		02 93	00/01	Send/read the MIC Up/Down Keyer setting (00=OFF, 01=ON)	
		RTTY DECODE SET: DECODE > <MENU1> > SET			
		02 94	00 ~ 03	Send/read the FFT Scope Averaging setting (00=OFF, 01=2, 02=3, 03=4)	
		02 95	See p. 21.	Send/read the FFT Scope Waveform Color setting	
		02 96	00/01	Send/read the Decode USOS setting (00=OFF, 01=ON)	

REMOTE CONTROL

Remote control (CI-V) information

◇ Command table

Cmd.	Sub cmd.	Data	Description
1A*	05	RTTY DECODE SET: DECODE > <MENU1> > SET	
	02 97	00/01	Send/read the Decode LineFeed Code setting (00=CR, LF, CR+LF, 01=CR+LF)
	02 98	00 ~ 02	Send/read the Diddle setting (00=OFF, 01=BLANK, 02=LTRS)
	02 99	00/01	Send/read the TX USOS setting (00=OFF, 01=ON)
	03 00	00/01	Send/read the TX Auto CR+LF by TX setting (00=OFF, 01=ON)
	03 01	00/01	Send/read the Time Stamp setting (00=OFF, 01=ON)
	03 02	00/01	Send/read the Time Stamp (Time) setting (00=Local, 01="CLOCK2 UTC Offset" setting)
	03 03	00/01	Send/read the Time Stamp (Frequency) setting (00=OFF, 01=ON)
	03 04	See p. 21.	Send/read the Font Color (Receive) setting
	03 05	See p. 21.	Send/read the Font Color (Transmit) setting
	03 06	See p. 21.	Send/read the Font Color (Time Stamp) setting
	03 07	See p. 21.	Send/read the Font Color (TX Buffer) setting
	RTTY 001: DECODE > TX MEM > EDIT/SET > 001 SET		
	03 08	00/01	Send/read the Count Up Trigger (RT1) setting (00=OFF, 01=ON)
	03 09	00/01	Send/read the Count Up Trigger (RT2) setting (00=OFF, 01=ON)
	03 10	00/01	Send/read the Count Up Trigger (RT3) setting (00=OFF, 01=ON)
	03 11	00/01	Send/read the Count Up Trigger (RT4) setting (00=OFF, 01=ON)
	03 12	00/01	Send/read the Count Up Trigger (RT5) setting (00=OFF, 01=ON)
	03 13	00/01	Send/read the Count Up Trigger (RT6) setting (00=OFF, 01=ON)
	03 14	00/01	Send/read the Count Up Trigger (RT7) setting (00=OFF, 01=ON)
	03 15	00/01	Send/read the Count Up Trigger (RT8) setting (00=OFF, 01=ON)
	03 16	00 01 ~ 99 99	Send/read the Present Number setting (00 01=1 ~ 99 99=9999)
	RTTY DECODE LOG: DECODE > <MENU1> > LOG		
	03 17	00/01	Send/read the Decode Log setting (00=OFF, 01=ON)
	03 18	00/01	Send/read the File Type setting (00=Text, 01=HTML)

Cmd.	Sub cmd.	Data	Description
1A*	05	PSK DECODE SET: DECODE > <MENU1> > SET	
	03 19	00 ~ 03	Send/read the FFT Scope Averaging setting (00=OFF, 01=2, 02=3, 03=4)
	03 20	See p. 21.	Send/read the FFT Scope Waveform Color setting
	03 21	00/01	Send/read the AFC Range setting (00=±8 Hz, 01=±15 Hz)
	03 22	00/01	Send/read the Time Stamp setting (00=OFF, 01=ON)
	03 23	00/01	Send/read the Time Stamp (Time) setting (00=Local, 01="CLOCK2 UTC Offset" setting)
	03 24	00/01	Send/read the Time Stamp (Frequency) setting (00=OFF, 01=ON)
	03 25	See p. 21.	Send/read the Font Color (Receive) setting
	03 26	See p. 21.	Send/read the Font Color (Transmit) setting
	03 27	See p. 21.	Send/read the Font Color (Time Stamp) setting
	03 28	See p. 21.	Send/read the Font Color (TX Buffer) setting
	PSK DECODE LOG: DECODE > <MENU1> > LOG		
	03 29	00/01	Send/read the Decode Log setting (00=OFF, 01=ON)
	03 30	00/01	Log Set > Send/read the File Type setting (00=Text, 01=HTML)
	SCAN SET: SCAN > SET		
	03 31	00/01	Send/read the SCAN Speed setting (00=Slow, 01=Fast)
	03 32	00/01	Send/read the SCAN Resume setting (00=OFF, 01=ON)
	VOICE TX: VOICE > TX LEVEL		
	03 33	00 00 ~ 02 55	Send/read the TX LEVEL setting (00 00=0% ~ 02 55=100%)
	VOICE TX SET: VOICE > REC/SET > SET		
	03 34	00/01	Send/read the Auto Monitor setting (00=OFF, 01=ON)
	03 35	01 ~ 15	Send/read the Repeat Time setting (01=1 sec. ~ 15=15 sec.)
	RECORD > Recorder Set		
	03 36	00/01	Send/read the TX REC Audio setting (00=Direct, 01= Monitor)
	03 37	00/01	Send/read the RX REC Condition setting (00=Always, 01=Squelch Auto)
	03 38	00/01	Send/read the File Split setting (00=OFF, 01=ON)
	03 39	00/01	Send/read the PTT Auto REC setting (00=OFF, 01=ON)
	03 40	00 ~ 03	Send/read the PRE-REC for PTT Auto REC setting (00=OFF, 01=5sec, 02=10sec, 03=15sec)

REMOTE CONTROL

Remote control (CI-V) information

◇ Command table

Cmd.	Sub cmd.	Data	Description	
1A*	05	RECORD > Player Set		
	03 41	00 ~ 03	Send/read the Skip Time setting (00=3sec, 01=5sec, 02=10sec, 03=30sec)	
	RECORD > Instant Replay Set			
	03 42	05 ~ 30	Send/read the REC Time setting (05=5 sec., ~ 30=30 sec.)	
	03 43	03 ~ 10	Send/read the Play Time setting (03=3 sec., ~ 10=10 sec.)	
	TYPE SET: ANTENNA > TYPE			
	03 44	00/01	Send/read the ANT2 Connector setting (00=OFF, 01=ON)	
	03 45	00/01	Send/read the ANT3 Connector setting (00=OFF, 01=ON)	
	03 46	00/01	Send/read the ANT4 Connector setting (00=OFF, 01=ON)	
	03 47	00/01	Send/read the RX-ANT Connectors setting (00=Connect an receive antenna, 01=Connect an external device)	
	03 48	00 ~ 03	Send/read the External Antenna Tuner Connection setting (00=ANT1 ~ 03=ANT4)	
	ANTENNA			
	03 49	See p. 21.	ANTENNA MEMORY (0.03 MHz ~ 1.60 MHz)	
	03 50	See p. 21.	ANTENNA MEMORY (1.60 MHz ~ 2.00 MHz)	
	03 51	See p. 21.	ANTENNA MEMORY (2.00 MHz ~ 6.00 MHz)	
	03 52	See p. 21.	ANTENNA MEMORY (6.00 MHz ~ 8.00 MHz)	
	03 53	See p. 21.	ANTENNA MEMORY (8.00 MHz ~ 11.00 MHz)	
	03 54	See p. 21.	ANTENNA MEMORY (11.00 MHz ~ 15.00 MHz)	
	03 55	See p. 21.	ANTENNA MEMORY (15.00 MHz ~ 20.00 MHz)	
	03 56	See p. 21.	ANTENNA MEMORY (20.00 MHz ~ 22.00 MHz)	
	03 57	See p. 21.	ANTENNA MEMORY (22.00 MHz ~ 26.00 MHz)	
	03 58	See p. 21.	ANTENNA MEMORY (26.00 MHz ~ 30.00 MHz)	
	03 59	See p. 21.	ANTENNA MEMORY (30.00 MHz ~ 45.00 MHz)	
	03 60	See p. 21.	ANTENNA MEMORY (45.00 MHz ~ 60.00 MHz)	
	03 61	00/01	Send/read the Temporary memory (TEMP-M) function setting (00=OFF, 01=ON)	
	03 62	00/01	Send/read the Antenna selection mode ([ANT] SW) setting (00=Manual, 01=Auto)	

Cmd.	Sub cmd.	Data	Description
1A*	05	NB: Function > NB (Touch for 1 second)	
	03 63	00 ~ 09	Send/read the DEPTH setting (00=1 ~ 09=10)
	03 64	00 00 ~ 02 55	Send/read the WIDTH setting (00 00=1 ~ 02 55=100)
	VOX: Function > VOX (Touch for 1 second)		
	03 65	00 ~ 20	Send/read the VOX delay setting (00=0.0 sec. ~ 20=2.0 sec.; 0.1 sec steps)
	03 66	00 ~ 03	Send/read the VOX Voice delay setting (00=OFF, 01=Short, 02=Mid, 03=Long)
	APF: Function > APF (Touch for 1 second)		
	03 67	00/01	Send/read the TYPE setting (00=SHARP, 01=SOFT)
	03 68	00 ~ 06	Send/read the AF LEVEL setting (00=0 dB ~ 06=6 dB)
	06	See p. 21.	Send/read the DATA mode setting
	07	00/01	Send/read the NTP server access (00=Terminate, 01=Initiate)
	08*1	00 ~ 02	Read the NTP server access result (00=Accessing, or have not accessed after Power ON, 01=Succeeded, 02=Failed)
	09 ㉔	00/01	Send/read the AF Mute setting (00=OFF, 01=ON)
	0A*1 ㉔	00/01	Read the OVF indicator status (00=OFF, 01=ON)
	0C	See p. 21.	Send/read the TX Power Limit setting ① You can also set in 1A 05 00 32 ~ 00 53.
	0D*1	00 ~ 04, FF	Read the External Tuner Connection (00=Not connected, 01=Connected to ANT1, 02=Connected to ANT2, 03=Connected to ANT3, 04=Connected to ANT4, FF=Getting connection status) ① Only Icom antenna tuners can be read.
	1B* ㉔	00	See p. 22.
	01	See p. 22.	Send/read the TSQL tone frequency
1C	00*	00/01	Send/read the transceiver's status (00=RX, 01=TX) ① When "CI-V Output (for ANT)" (Command: 1C 04) is set to "ON," automatically outputs when changed.
	01*	00 ~ 02	Send/read the Antenna tuner setting (00=OFF, 01=ON, 02=Tune)
	02*	00/01	Send/read the Transmit frequency monitor (XFC) (00=OFF, 01=ON)
	03	See p. 16.	Read the transmit frequency ① When "CI-V Output (for ANT)" (Command: 1C 04) is set to "ON," automatically outputs when changed.

REMOTE CONTROL

Remote control (CI-V) information

◇ Command table

Cmd.	Sub cmd.	Data	Description
1C	04*	00/01	Send/read the CI-V Output (for ANT) setting (00=OFF, 01=ON)
1E	00		Read number of available TX frequency band
	01	See p. 16.	Read TX band edge frequencies
	02		Read number of user-set TX frequency band
	03*	See p. 16.	Send/read user-set TX band edge frequencies
21*	00	See p. 22.	Send/read the RIT/ Δ TX frequency
	01	00/01	Send/read the RIT setting (00=OFF, 01=ON)
	02	00/01	Send/read the Δ TX setting (00=OFF, 01=ON)
25*		See p. 22.	Send/read the Main or Sub band frequency
26*		See p. 22.	Send/read the operating mode and filter settings (for both Main and Sub bands)
27*	00	See p. 23.	Read the Scope waveform data (Only when "Scope ON/OFF status" (Command: 27 10) and "Scope wave data output" (Command: 27 11) are set to "ON," outputs the waveform data to the controller.)
	10	00/01	Send/read the Scope ON/OFF status (00=OFF, 01=ON)
	11* ⁶	00/01	Send/read the Scope wave data output setting (00=OFF, 01=ON)
	SCOPE > MAIN/SUB		
	12	00/01	Send/read the Main or Sub scope setting (00=Main, 01=Sub)
	SCOPE > DUAL		
	13	00/01	Send/read the Single/Dual scope setting (00=Single, 01=Dual)
	SCOPE > CENT/FIX (Touch/Touch for 1 second)		
	14	See p. 23.	Scope Center mode, Fixed mode, SCROLL-C mode, or SCROLL-F mode setting
	SCOPE > SPAN (Touch/Touch for 1 second)		
	15	See p. 24.	Send/read the Span setting in the Center mode or SCROLL-C mode Scope
SCOPE > EDGE			
16	See p. 24.	Send/read the Scope Edge Number setting in the Fixed mode or SCROLL-F mode	
SCOPE > HOLD			
17	See p. 24.	Send/read the Scope Hold function ON/OFF status	
SCOPE > REF			
19	See p. 24.	Send/read the Scope Reference level setting	

Cmd.	Sub cmd.	Data	Description
27*	SCOPE > SPEED		
	1A	See p. 24.	Send/read the Scope Sweep speed setting
	SCOPE SET: SCOPE > EXPD/SET (Touch for 1 second)		
	1B	00/01	Send/read the Scope during Tx (CENTER TYPE) setting (00=OFF, 01=ON)
	1C	00 ~ 02	Send/read the CENTER Type Display setting (00=Filter Center, 01=Carrier Point Center, 02=Carrier Point Center (Abs. Freq.))
	SCOPE > VBW		
	1D	See p. 24.	Send/read the Scope VBW setting
	SCOPE > EXPD/SET (Touch for 1 second) > Fixed Edges		
	1E	See p. 25.	Send/read the Scope Fixed Edge frequencies
	SCOPE > RBW		
	1F	See p. 24.	Send/read the Scope RBW setting
	SCOPE SET: SCOPE > EXPD/SET (Touch for 1 second)		
	20	00/01	Send/read Marker Position (FIX Type/SCROLL Type) setting (00=Filter Center, 01=Carrier Point)
28	00	00 ~ 08	Transmit the Voice TX Memory (00=Stop, 01=T1 ~ 08=T8)
29		00 or 01 + Supported commands See p. 25.	Regardless of active/inactive the Main or Sub band, you can directly specify the Main or Sub band, and send/read the supported command settings. (00=MAIN, 01=SUB)

*(Asterisk) Send/read data

^② Command 29 supported.

*¹ 1A 05 01 63, 1A 08, 1A 0A, and 1A 0D cannot be sent.

*² If the Antenna Type is set to "RX-I/O," command "01 (RX ANT ON)" is invalid and "00 (RX ANT OFF)" is always returned.

*³ If the Antenna Type is set to "RX-ANT," command "01 (ON)" is invalid and "00 (OFF)" is always returned.

*⁴ In the CW mode, if the transceiver transmits or the Break-in function is ON, a message will be transmitted as CW code when you send it from your PC.

*⁵ Sending the power ON command (18 01) turns ON the transceiver when the [USB B] port on the controller's rear panel is connected to the PC and the transceiver is OFF (Standby/Shutdown).

① When the transceiver is remotely controlled through the [REMOTE] jack on the RF deck's rear panel, the transceiver is not turned ON even if the command is sent.

*⁶ Valid only when the [REMOTE] jack on the RF deck's rear panel or the [USB B] port on the controller's rear panel is connected.

Remote control (CI-V) information

◆ Command formats

• Operating frequency

Command: 00, 03, 05, 1C 03

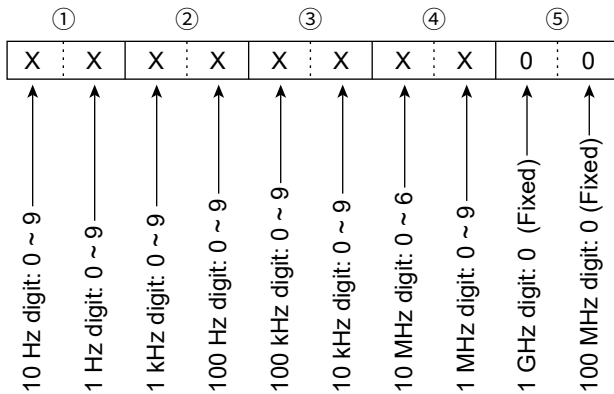

• Operating mode

Command: 01, 04, 06

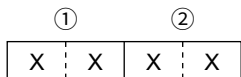

① Operating mode		② Filter setting
00:LSB	05:FM	01: FIL1
01:USB	07:CW-R	02: FIL2
02:AM	08:RTTY-R	03: FIL3
03:CW	12:PSK	—
04:RTTY	13:PSK-R	—

① Filter setting (②) can be skipped with commands 01 and 06. In that case, "FIL1" is selected with command 01 and the default filter setting of the operating mode is automatically selected with command 06.

• Codes for CW message contents

Command: 17 (Up to 30 characters)

To send CW messages, use the following character codes.

Character	ASCII code	Character	ASCII code
0 ~ 9	30 ~ 39	'	27
A ~ Z	41 ~ 5A	(28
a ~ z	61 ~ 7A)	29
/	2F	=	3D
?	3F	+	2B
.	2E	"	22
-	2D	@	40
,	2C	^	5E
:	3A	Space	20

① "FF" stops sending CW messages.

① "A" is used to transmit a string of characters with no inter-character space.

• Band edge frequency settings

Command: 02*, 1E 01, 1E 03

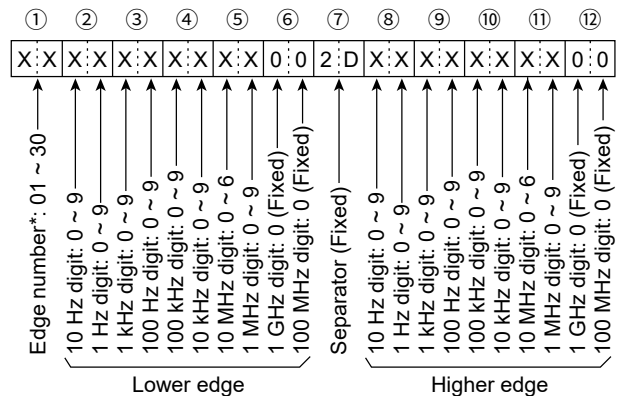

* When obtaining the edge number (by command "02"), the edge number (①) is not returned.

REMOTE CONTROL

Remote control (CI-V) information

◇ Command formats

• Band stacking register

Command: 1A 01

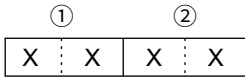

NOTE: When sending the contents, the codes, such as operating frequency and operating mode*, should be added after the frequency band code and the register code, as shown below.

* See ④ ~ ⑰ on "Memory content." (p. 18)

①: Frequency band codes

Code	Freq. band	Frequency range (unit: MHz)
01	1.8	1.800000 ~ 1.999999
02	3.5	3.400000 ~ 4.099999
03	7	6.900000 ~ 7.499999
04	10	9.900000 ~ 10.499999
05	14	13.900000 ~ 14.499999
06	18	17.900000 ~ 18.499999
07	21	20.900000 ~ 21.499999
08	24	24.400000 ~ 25.099999
09	28	28.000000 ~ 29.999999
10	50	50.000000 ~ 54.000000
11	GENE	Other than above

②: Register codes

Code	Registered number
01	1 (Display on left side)
02	2 (Display in center)
03	3 (Display on Right side)

To read the contents, the register code should be added after the frequency band code, as shown below.

Example: When reading the frequency displayed in the center of the display in the 21 MHz band, use code "07 02."

REMOTE CONTROL

Remote control (CI-V) information

◇ Command formats

• Memory content

Command: 1A 00

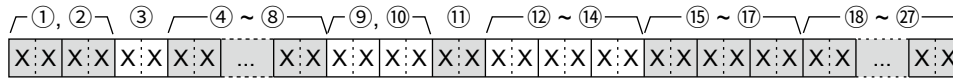

- ①, ②: Memory group number
00 01 ~ 00 99: Memory channel 01 ~ 99
- 01 00: Programmed scan edge P1
- 01 01: Programmed scan edge P2

③: Select memory setting

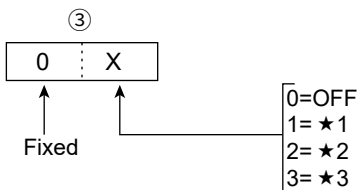

① Set 0 for P1 and P2.

④ ~ ⑧: Operating frequency setting

① See “• Operating frequency.” (p. 16)

⑨, ⑩: Operating mode setting

① See “• Operating mode.” (p. 16)

⑪: Data mode and tone type settings

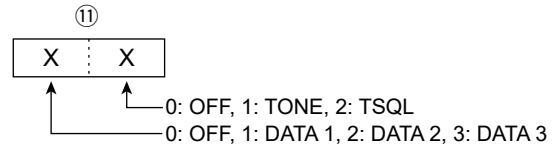

⑫ ~ ⑭: Repeater tone frequency setting

⑮ ~ ⑰: Tone squelch frequency setting

① See “• Repeater tone/tone squelch settings.” (p. 22)

⑱ ~ ⑳: Memory name settings

Up to 10 characters.

① See “• Codes for character entries.”

To clear the memory channel contents on 1A 00:

①, ②: Memory channel (00 01~00 99)

③: “FF”

④: None

• Codes for character entries

Command: 1A 00,

1A 05 01 76, 01 83, 01 98, 02 03, 02 07

- Character codes— Letters and Numbers

Character	ASCII code	Character	ASCII code
A ~ Z	41 ~ 5A	a ~ z	61 ~ 7A
0 ~ 9	30 ~ 39		

- Character codes— Symbols

Character	ASCII code	Character	ASCII code
!	21	#	23
\$	24	%	25
&	26	\	5C
?	3F	”	22
,	27	`	60
^	5E	+	2B
-	2D	*	2A
/	2F	.	2E
,	2C	:	3A
;	3B	=	3D
<	3C	>	3E
(28)	29
[5B]	5D
{	7B	}	7D
	7C	_	5F
~	7E	@	40

Cmd.	Sub cmd.	Set item/selectable characters
1A	00	Memory name*
	05 01 76	Network > Network Name (up to 15 characters) A to Z, 0 to 9, ! " # \$ % & () + , - . ; = @ [] ^
	01 83	Network > Network Radio Name* (up to 16 characters) ① Illegal characters: \ (space)
	01 98	Display > My Call (up to 10 characters) A to Z, 0 to 9, / @ - .
	02 03	Time Set > Date/Time > NTP Server Address A to Z, a to z, 0 to 9, - .
	02 07	Time Set > CLOCK2 Name* (up to 3 characters)

* Usable characters: A to Z, a to z, 0 to 9, (space), ! " # \$ % & ' () * + , - .
/ ; < = > ? @ [\] ^ _ { | } ~

REMOTE CONTROL

Remote control (CI-V) information

◇ Command formats

• Keyer memory character entries

Command: 1A 02

- Character codes

Character	ASCII code	Description
0 ~ 9	30 ~ 39	Numbers
A ~ Z	41 ~ 5A	Letters
Space	20	Word space
/	2F	Symbol
?	3F	Symbol
,	2C	Symbol
.	2E	Symbol
@	40	Symbol
^	5E	Example: to send \overline{BT} , enter "5E 42 54"
*	2A	Inserts the contest number

① Information

- Spaces after the end of the sentence are not necessary.
- To clear the Keyer memory contents, send one or more spaces.

• Keyer memory content

Command: 1A 02

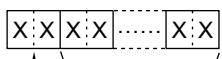

- ①: Channel data
 01=M1 05=M5
 02=M2 06=M6
 03=M3 07=M7
 04=M4 08=M8

• IF filter width settings

Command: 1A 03

Mode	Data	Steps
SSB/CW/ RTTY/PSK	00 ~ 09	50 ~ 500 Hz (50 Hz)
SSB/CW/PSK	10 ~ 40	600 Hz ~ 3.6 kHz (100 Hz)
RTTY	10 ~ 31	600 Hz ~ 2.7 kHz (100 Hz)
AM	00 ~ 49	200 Hz ~ 10.0 kHz (200 Hz)

• AGC time constant settings

Command: 1A 04

Data	AGC time constant (sec.)	
	SSB/CW/RTTY/PSK	AM
00	OFF	OFF
01	0.1	0.3
02	0.2	0.5
03	0.3	0.8
04	0.5	1.2
05	0.8	1.6
06	1.2	2.0
07	1.6	2.5
08	2.0	3.0
09	2.5	4.0
10	3.0	5.0
11	4.0	6.0
12	5.0	7.0
13	6.0	8.0

• RX HPF/LPF settings for each operating mode

Command: 1A 05 00 01, 00 04, 00 07,
 00 10, 00 11, 00 12

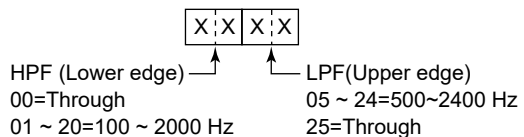

① The value of the HPF should be smaller than the LPF.

• SSB/SSB-DATA transmission passband width settings

Command: 1A 05 00 15, 00 16, 00 17, 00 18

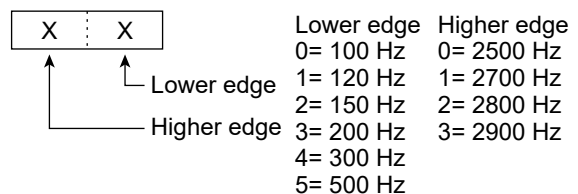

REMOTE CONTROL

Remote control (CI-V) information

◇ Command formats

• Split offset frequency setting

Command: 1A 05 00 60, 00 61, 00 65

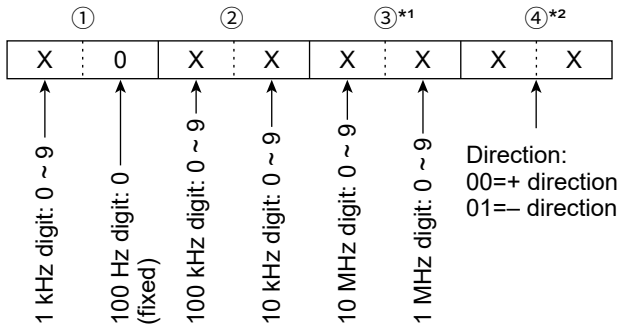

*1 Transverter offset only. Fix to '0' for split offset setting.

*2 No need to enter for the transverter offset frequency setting.

• [VOX/BK-IN] setting

Command: 1A 05 00 88

Data	Function
00	VOX/BK-IN
01	PRESET
02	Voice/Keyer/RTTY/PSK Memory 1
03	Voice/Keyer/RTTY/PSK Memory 2
04	Voice/Keyer/RTTY/PSK Memory 3
05	Voice/Keyer/RTTY/PSK Memory 4

• [AUTOTUNE] setting

Command: 1A 05 00 89

Data	Function
00	AUTOTUNE
01	PRESET
02	Voice/Keyer/RTTY/PSK Memory 1
03	Voice/Keyer/RTTY/PSK Memory 2
04	Voice/Keyer/RTTY/PSK Memory 3
05	Voice/Keyer/RTTY/PSK Memory 4

• Remote MIC Key setting

Command: 1A 05 00 90, 00 91

Data	Function
00	No function
01	UP
02	DOWN
03	UP (VFO: kHz)
04	DOWN (VFO: kHz)
05	XFC
06	VFO/MEMO
07	BAND UP
08	BAND DOWN
09	SPEECH
10	MODE
11	Voice/Keyer/RTTY/PSK Memory 1
12	Voice/Keyer/RTTY/PSK Memory 2
13	Voice/Keyer/RTTY/PSK Memory 3
14	Voice/Keyer/RTTY/PSK Memory 4
15	TS
16	MPAD
17	SPLIT
18	CHANGE
19	TUNER

• IP address setting

Command: 1A 05 01 62, 01 63, 01 64, 01 65, 01 67, 01 68, 01 69, 01 72, 01 74

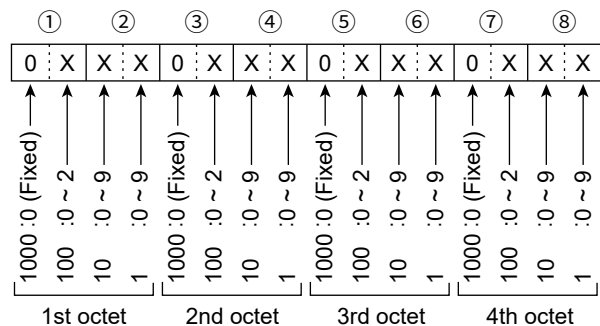

① Set each octet to 00 00 ~ 02 55.

① FF = blank in command 1A 05 01 67, 01 68, 01 69, and 01 74.

REMOTE CONTROL

Remote control (CI-V) information

◇ Command formats

• UTC Offset setting

Command: 1A 05 02 04, 02 06

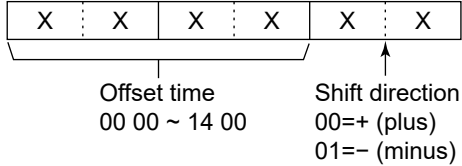

• Color settings

Command: 1A 05 01 93, 02 14, 02 15, 02 16,
02 73, 02 75, 02 95, 03 20,
03 04, 03 05, 03 06, 03 07,
03 25, 03 26, 03 27, 03 28

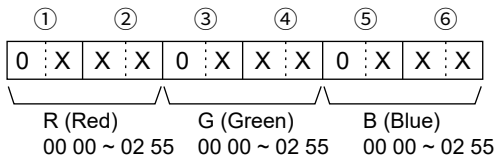

• Bandscope edge frequency settings

Command: 1A 05 02 24 ~ 02 71

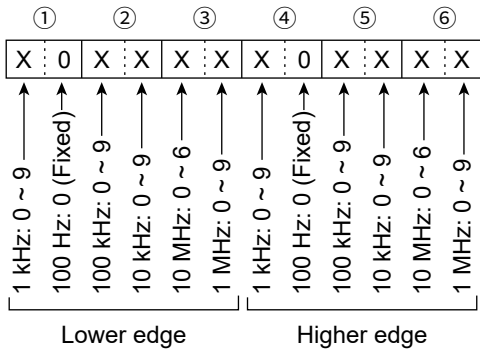

• Antenna memory settings

Command: 1A 05 03 49 ~ 03 60

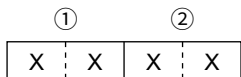

① ANT No.	② RX-ANT or RX-I/O
00: ANT 1	00: RX-ANT or RX-I/O OFF
01: ANT 2	01: RX-ANT or RX-I/O ON* *Depending on the selected antenna type.
02: ANT 3	
03: ANT 4	

• Data mode with filter width settings

Command: 1A 06

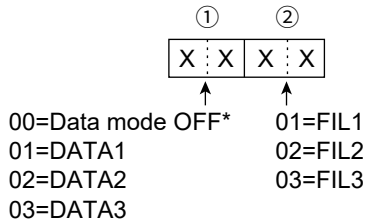

*When 00 is set, also set 00 to ②.

• TX Power Limit setting

Command: 1A 0C

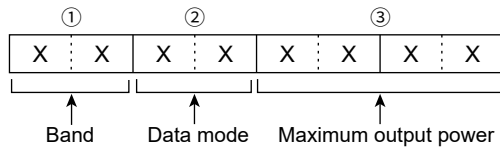

① Band	② Data mode	③ Maximum output power
01=1.8 MHz	07=18 MHz	01=OFF
02=3.5 MHz	08=21 MHz	02=ON (D1 ~ D3)
03= 5 MHz	09=24 MHz	00 02 = 2 W ~
04= 7 MHz	10=28 MHz	02 00 = 200 W
05=10 MHz	11=50 MHz	
06=14 MHz		

REMOTE CONTROL

Remote control (CI-V) information

◇ Command formats

• Repeater tone/tone squelch frequency settings

Command: 1B 00, 1B 01

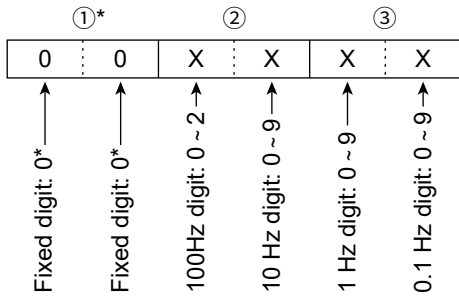

*Not necessary when setting a frequency.

• RIT/ΔTX frequency settings

Command: 21 00

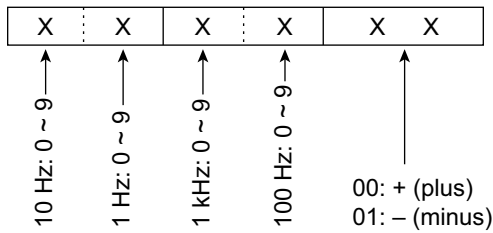

• Main or Sub band's frequency settings

Command: 25

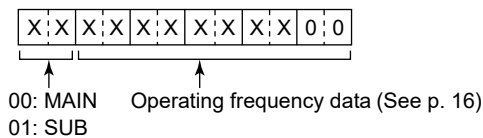

• Main or Sub band's operating mode and filter settings

Command: 26

Both data and filter settings can be skipped. In that case, "DATA OFF" and the default filter setting of the operating mode is automatically selected.

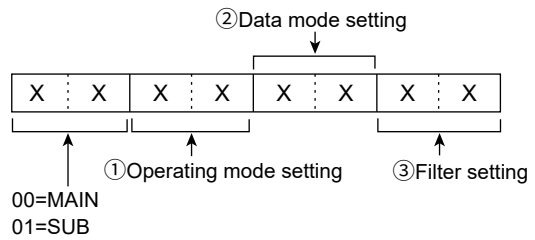

① Operating mode setting		② Data mode setting		③ Filter setting	
00:LSB	05:FM	00: Data mode OFF		01:FIL1	
01:USB	07:CW-R	01: Data mode 1 (D1)		02:FIL2	
02:AM	08:RTTY-R	02: Data mode 1 (D2)		03:FIL3	
03:CW	12:PSK	03: Data mode 1 (D3)		—	
04:RTTY	13:PSK-R	—		—	

REMOTE CONTROL

Remote control (CI-V) information

◇ Command formats

• Scope waveform data

Command: 27 00

Outputs the waveform data to the controller (PC).

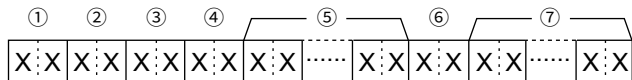

- ①: Main or Sub scope data
 - 00=Main scope, 01=Sub scope
- ②: Order of division data (Current): 01~15
- ③: Division number (Maximum): 01(LAN), 15(USB)

When data is sent to the controller (PC) using the RF deck's [LAN] port, all data is sent together. However, when the data is sent through the [USB B] port on the controller's rear panel, the data is divided by 15 and sent in sequential order.

	Division number	Data length	
LAN	01	704	
USB	15	1st data	15
		2nd or later data	53
		15th data	42

The 1st data sends only the wave information (① ~ ⑥) without the waveform data (⑦). The 2nd or later data sends the Main or Sub scope data (①), the order of division data (Current) (②), the division number (Maximum) (③), and the waveform data (⑦).

- ④: Spectrum scope mode data:
 - 00 = Center mode scope
 - 01 = Fixed mode scope
 - 02 = SCROLL-C mode scope
 - 03 = SCROLL-F mode scope

⑤: Waveform information:

The waveform information differs, depending on the Spectrum scope mode.

- In the Center mode:
 - Center frequency and span are sent.
 - See page 16 for Operating frequency data, and page 24 for the Scope span settings (② ~ ⑥).
- In the Fixed, SCROLL-C, and SCROLL-F modes:
 - Lower edge and higher edge frequencies are sent.

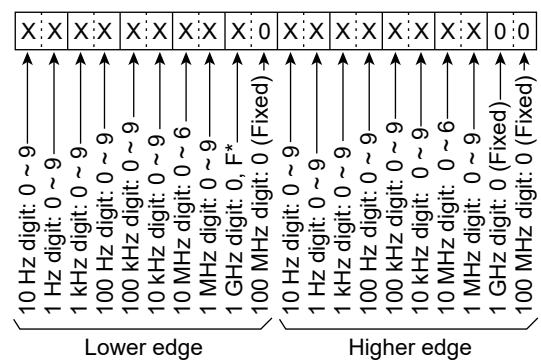

① "F" means that the Lower edge frequency is a negative value.

⑥: Out of range information:

- 00 = In range
- 01 = Out of range
- ① If the scope data is out of range, the waveform data (⑦) is omitted.

⑦: Waveform data:

The transceiver outputs the drawn waveform data. The data range or data length of the waveform data is judged by the controller (PC). (The data range is basically the same as the display size of the scope on the controller (PC).)

- Data range: 00 ~ C8 (0 ~ 200)
- Data length: 689

• Spectrum scope mode settings

Command: 27 14

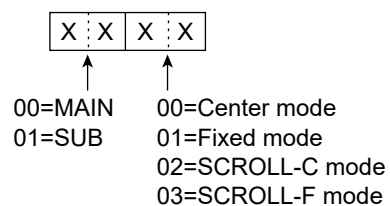

REMOTE CONTROL

Remote control (CI-V) information

◇ Command formats

• Scope span settings

(in the Center mode and SCROLL-C mode Scope)

Command: 27 15

		Span (kHz)			
①	X	②	0	2500	2.5
③	X	④	X	5000	5
⑤	0	⑥	0	10000	10
⑦	X	⑧	X	25000	25
⑨	X	⑩	X	50000	50
⑪	0	⑫	0	100000	100
⑬	X	⑭	X	250000	250
⑮	X	⑯	X	500000	500

00: MAIN
 01: SUB

10 Hz digit: 0 (Fixed)
 1 Hz digit: 0 (Fixed)
 1 kHz digit: 0, 2, 5
 100 Hz digit: 0, 5
 100 kHz digit: 0, 1, 2, 5
 10 MHz digit: 0, 1, 2, 5
 10 MHz digit: 0 (Fixed)
 1 MHz digit: 0 (Fixed)
 1 GHz digit: 0 (Fixed)
 100 MHz digit: 0 (Fixed)

• Scope Edge number settings

(in the Fixed mode and SCROLL-F mode Scope)

Command: 27 16

		Edge	
00	MAIN	01	Edge 1
01	SUB	02	Edge 2
		03	Edge 3
		04	Edge 4

• Scope Hold settings

Command: 27 17

		Hold	
00	MAIN	00	Hold OFF
01	SUB	01	Hold ON

• Scope Reference level settings

Command: 27 19

		Scope		Reference level	
00	Main scope	00	+	0	0
01	Sub scope	01	-	0	0
				10	dB
				1	dB
				0.1	dB
				0.01	dB

00=Main scope
 01=Sub scope

00= + (plus)
 01= - (minus)

10 dB digit: 0 ~ 3
 1 dB digit: 0 ~ 9
 0.1 dB digit: 0, 5
 0.01 dB digit: 0 (Fixed)

Adjustable range: -30.0 dB ~ +10.0 dB
in 0.5 dB steps.

• Scope Sweep speed settings

Command: 27 1A

		Sweep speed	
00	MAIN	00	FAST
01	SUB	01	MID
		02	SLOW

• Scope VBW (Video Band Width) settings

Command: 27 1D

		VBW	
00	MAIN	00	Narrow
01	SUB	01	Wide

• Scope RBW (Resolution Band Width) settings

Command: 27 1F

		RBW	
00	MAIN	00	WIDE
01	SUB	01	MID
		01	NAR

REMOTE CONTROL

Remote control (CI-V) information

◇ Command formats

• Scope Fixed edge frequency settings

Command: 27 1E

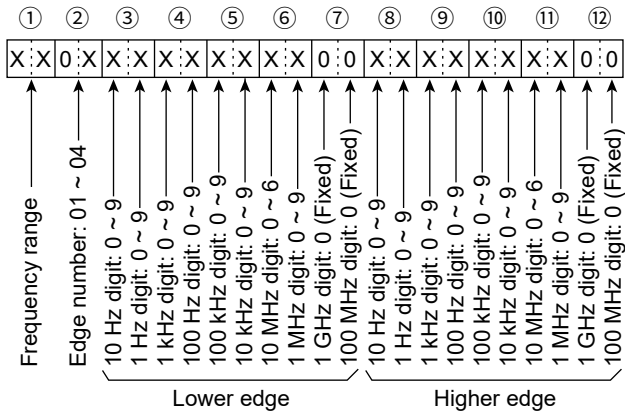

① Entry of less than 1 kHz digits are ignored.

① Selectable Frequency ranges:

Data	Frequency range (unit: MHz)
01	0.03 ~ 1.60
02	1.60 ~ 2.00
03	2.00 ~ 6.00
04	6.00 ~ 8.00
05	8.00 ~ 11.00
06	11.00 ~ 15.00
07	15.00 ~ 20.00
08	20.00 ~ 22.00
09	22.00 ~ 26.00
10	26.00 ~ 30.00
11	30.00 ~ 45.00
12	45.00 ~ 60.00

② Selectable Edge number: 01=1, 02=2, 03=3, 04=4

• Directly specify the Main or Sub band and send/read the supported command

Command: 29

Specify the Main or Sub band before entering the supported commands.

When you receive the OK code (FB), or the NG code (FA), the Command 29 and Main/Sub specify (00 or 01) is omitted.

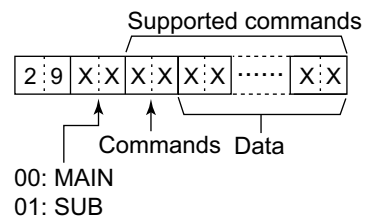

The supported commands are marked by “29” in the command table.

