

SYSTEM BASE BO-9



BO-9 PARTS LIST

BO-9 SPECIFICATIONS

Input voltage	AC120V (K) $\pm 10\%$, 50 ~ 60 Hz 220~240V(T)(W)(X)
Buck up output	DC13.8V, 1.5 mA
AC outlet output	AC120V (K) 200W (MAX) 220~240V(T)(W)(X)
Dimensions	170 (6-11/16") \times 25 (1") \times 232 (9-9/64") mm (inch)
Weights	Approx. 1.0 kg (2.2 lbs)

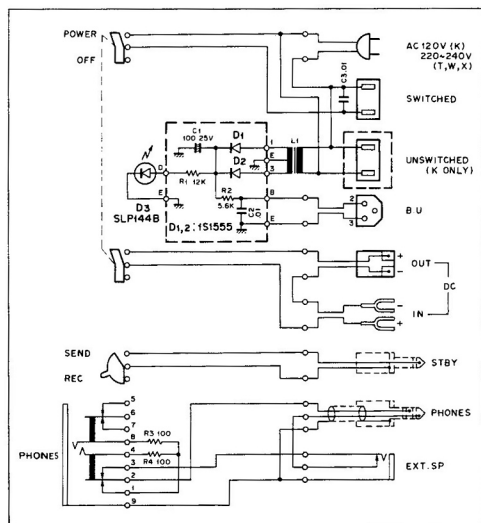

Ref. No.	Parts No.	Description	Remarks
C1	CE04W1E101Q	E 100 μ F 25V	
C2,3	CK45F1H103Z	C 0.01 μ F +80.-20%	
R3,4	RC05GF2H101J	Solid 100 Ω $\pm 5\%$ 1/2W	
D1,2	V11-0076-05	Diode 1S1555	
D3	V11-6172-56	LED SLP144B	
—	A01-0767-02	Case (upper)(K)	☆
—	A01-0768-03	Case (bottom)	☆
—	A01-0769-02	Case (upper)(W)(T)(X)	☆
—	A20-2374-05	Panel (T)	☆
—	A20-2375-05	Panel (K)(W)(X)	☆
—	B46-0058-00	Warranty card (K)	☆
—	B50-2708-00	Operating manual (K)	☆
—	B50-2709-00	Operating manual (W)(T)(X)	☆
—	E03-0153-05	AC Outlet	☆
—	E03-0154-05	AC Plug (W)(T)(X)	☆
—	E11-0404-05	Phone jack	☆
—	E11-0410-05	Phone jack	☆
—	E22-0306-05	Lug plate	☆
—	E30-0181-05	AC cord (K)	
—	E30-0185-05	AC cord (X)	
—	E30-0585-05	AC cord (W)	
—	E30-0602-05	AC cord (T)	
—	E30-1653-15	DC cord	☆
—	E30-1654-05	Cord with $\phi 2.5$ plug	☆
—	E30-1655-05	Cord with ST plug	☆
—	E30-1656-05	DC cord ass'y	☆
—	E30-1657-05	3P power cord BACK UP	☆
—	H01-2665-04	Carton (inside)(T)	☆
—	H01-2667-04	Carton (inside)(K)(W)(X)	☆
—	H10-2532-04	Cushion foam $\times 4$	☆
—	H12-0467-03	Cushion	☆
—	H25-0029-04	Protective bag (W)(T)(X)	
—	H25-0103-04	Protective bag 125 \times 250 mm	
—	H25-0106-04	Protective bag 250 \times 350 mm	
—	J02-0323-05	Foot $\times 4$	
—	J19-1325-04	Stopper plate $\times 4$	
—	J25-2732-04	PC board	☆
—	J41-0006-05	Cord bush	
—	L01-0150-05	Transformer (K)	
—	L01-8022-05	Transformer (W)(T)(X)	☆
—	N35-3004-45	Bind screw	
—	N35-3006-45	Bind screw	
—	S36-2405-05	Power switch	☆
—	S44-2404-05	STBY switch	☆