

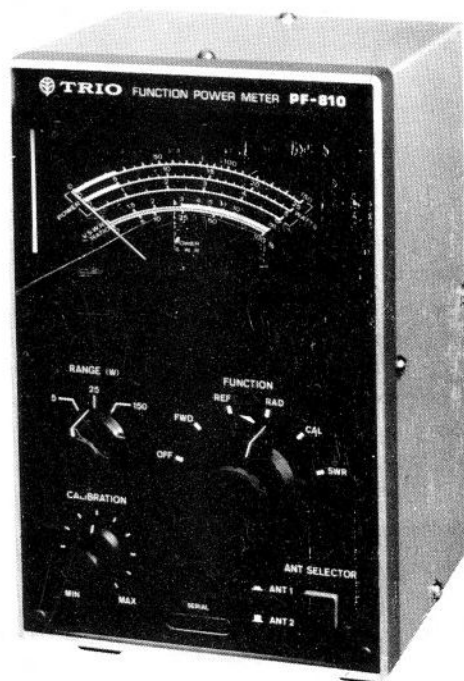

FUNCTION POWER METER
PF-810



OPERATING INSTRUCTIONS

CONTENTS

Introduction	3
Features	4
Specifications	4
Principles of operation	5
Operating parts	7
Cautions	9
Operation	9
Schematic diagram	12
Smith chart	13
Applications	14

INTRODUCTION

The Function Power Meter Model PF-810 is a passing type power/SWR meter covering a wide frequency range of 1.8MHz to 200MHz. It is a laboratory quality, professional instrument for observing and measuring forward power from transmitter to load (antenna) and reflection power from load to transmitter.

It is also capable of measuring power actually consumed in load (forward power minus reflection power) for convenience of checking the conditions of transmitter and load, in addition to measuring SWR at power greater than 1W.

Besides being used to monitor the operating conditions of transmitter or to adjust filters, matching circuit, etc., it is also used to monitor production lines and business use radio stations.

FEATURES

- * Troidal core type directional coupler assures flat frequency response, eliminating the need for calibration tables; calculations and handling knob of frequency variation.
- * Frequencies are practically flat over the range of 1.8 MHz to 200MHz in full scale of meter even in 1.9MHz or 3.5MHz band, thus permitting measurements of various functions in low bands with small power.
- * Radiant power (RAD) indicator (Pat. pending) to indicate forward power minus reflection power, is included in the instrument. This is particularly useful to prevent trouble which might occur during matching work, and facilitates monitoring and adjustments of transmitter.
- * Antenna selector switch is self-contained to select either of two antennas for quick QSY. If a dummy load is connected instead of antenna, the instrument functions as a terminal type power meter.
- * Large sized, linear scale for easy and error-free reading of SWR and power.

SPECIFICATIONS

Measurement items:	Forward power, reflection power, radiant power and SWR
Frequency range:	1.8MHz to 200MHz
Power measurement range:	1W to 150W
Range setting:	5W, 25W and 150W(3 ranges)
SWR measurement range:	1.0 to 10
Minimum power for SWR measurement:	1W
Power measurement accuracy:	Within $\pm 10\%$ of full scale
Residual SWR:	Less than 1.2
Frequency response:	Within $\pm 0.25\text{dB}$
Insertion Loss:	Less than 0.5dB
Type of connector:	"UHF" type
Input/output impedance:	50-ohm
Output terminal:	Two (selected by pushbutton switch)

PRINCIPLES of OPERATION

The Model PF-810 is composed of four major units, a directional coupler, a voltage converter, an indicator and a switching unit; all units except the antenna selector and the directional coupler, function as a DC circuit.

Directional coupler

The directional coupler is used to pick up a very small power from the coaxial cable connected between transmitter and load by separating forward wave and reflection wave components.

The directional coupler used in PF-810 consists of a wide band current transformer T1 and a voltage transformer T2, both employing toroidal cores as shown in Fig. 1.

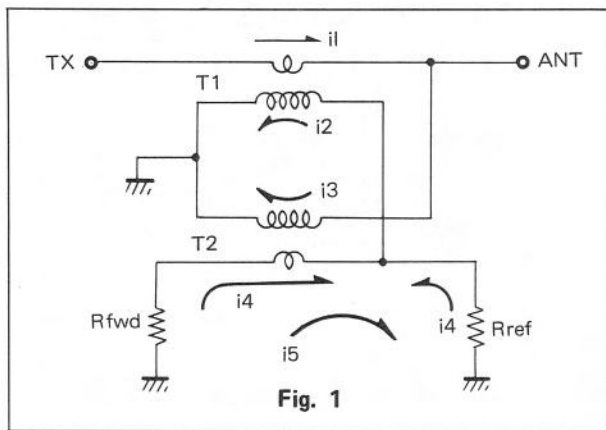

1 In Fig. 1, suppose that a current " i_1 " flows from TX to ANT, then a reverse current " i_2 " flows into the secondary of the current transformer T2. At this time, a current " i_3 " is flowing into the primary of the voltage transformer and, hence, a current " i_4 " ($=i_2/2$) developed from " i_2 " and a current " i_5 " developed from " i_3 " together flow into the secondary of the transformer.

If these two currents (i_4 and i_5) are equal, no voltage appears across "Rref" because the currents flowing into "Rref" in reverse direction each other are cancelled, however, a voltage appears across "Rfwd" because the currents flowing into "Rfwd" have the same directivity.

If power is reflected by ANT, the current " i_5 " continues to flow in the same direction, while the current " i_4 " flows in reverse direction, thus a voltage appears across "Rref", too. Such an action is independent of frequencies if T1 and T2 each have a wide frequency band.

The directional coupler of PF-810 uses wide band transformers constructed with toroidal core and newly developed windings, to pick up the diode detected voltage, proportional to forward power and reflection power, from the resistors of "Rfwd" and "Rref".

Voltage converter

The voltage converter is used to provide linear readings of power on the scale. Without this converter, the DC voltage from the directional coupler, which is proportional to forward power or reflection power, is proportioned to the square root of power, thus the

readings on the scale are crowded which causes difficulty in reading or loss of reading accuracy.

The voltage converter uses specially selected diodes, resistors and capacitors. The same type of converter is connected to both the forward power and reflection power terminals.

Indication and selection

The voltage signal from the voltage converter, which is proportional to power, is indicated on the $100\mu\text{A}$ DC ammeter through the function selector switch. The power range is selected by the range selector resistors. Two sets of voltage converter and selector of the same design are provided for forward power and reflection power. These can be used simultaneously. Being so designed, PF-810 is able to indicate radiant power (RAD). This is achieved by the differential operation of the voltage converters to which forward and reflection wave voltages applied respectively.

In PF-810, two identical circuits are connected back to back to further improve the performance of the directional coupler.

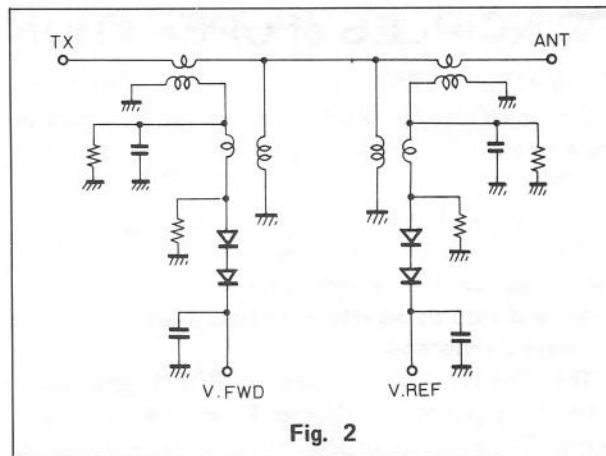

Fig. 2

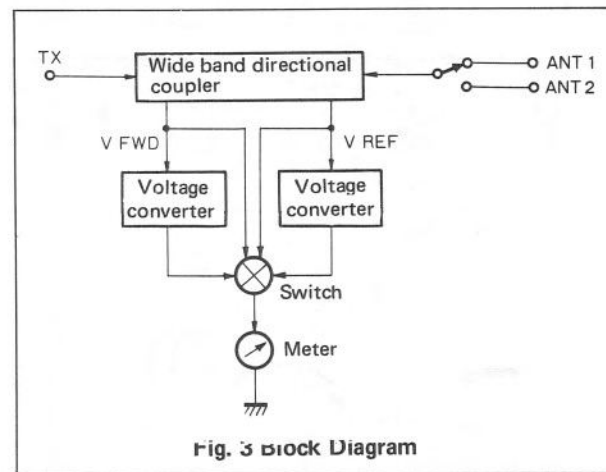

Fig. 3 Block Diagram

OPERATING PARTS

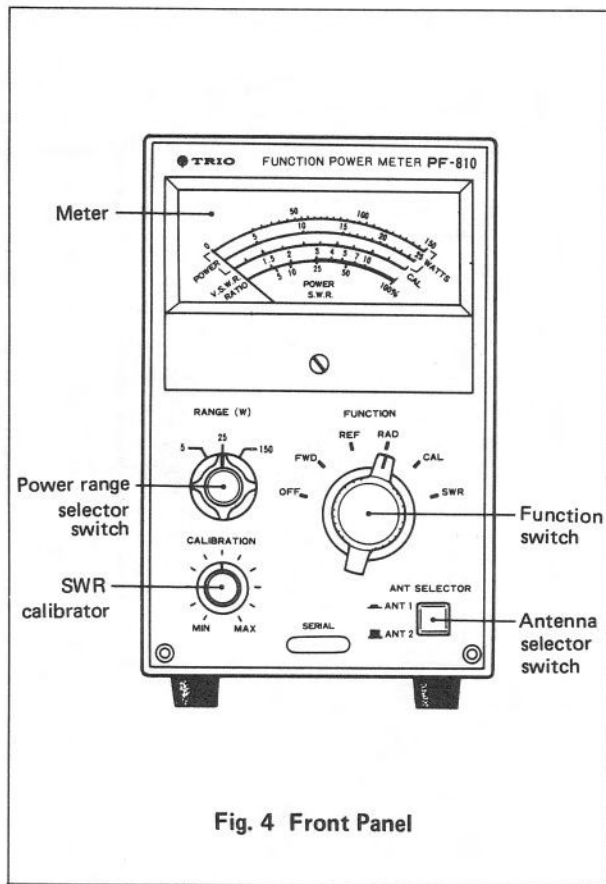

Fig. 4 Front Panel

Front panel (Fig. 4)

Function switch (FUNCTION)

The function switch is used to select the desired function to be measured. This rotary switch has 6 positions, OFF—FWD—REF—RAD—CAL—SWR.

At the OFF position, the meter circuit is disconnected and the meter becomes inoperative, but the power is still on and the antenna selector switch remains operative.

At the FWD (forward) position, forward power from transmitter to load is measured on the meter.

At the REF (refraction) position, refraction power from load to transmitter is measured on the meter.

At the RAD (radiant) position, radiant power, that is, forward power minus refraction power ($RAD = FWD - REF$), is measured on the meter. In the absence of refraction, the reading of FWD is practically equal to that of RAD.

In measuring SWR, the function switch should be set to CAL position and then to SWR position. First set the switch to the CAL position and turn the calibration knob so that the pointer indicates the CAL position on the meter, then set the switch to the SWR position and the value of SWR can be measured on the meter. A right turn of the calibration knob will swing the pointer to the right, and vice versa. Adjust the knob for accurate calibration. Do not turn this knob after the function switch is set to the SWR position.

*** Power range selector (RANGE)**

The power range selector is used to select the proper power range, 5W, 25W or 150W, according to the output of transmitter. For easy reading, set the meter pointer in approximate center position of the scale. Since refraction power is small, set the selector to a smaller range with the function switch in the REF position.

*** Antenna selector (ANT SELECTOR)**

This 2-position pushbutton switch is used to connect the transmitter to ANT1 or ANT2. Press the button until it locks and the transmitter is connected to ANT1. By releasing the button, the transmitter is connected to ANT2.

*** Rear panel (Fig. 5)**

TX: For connection of coaxial cable from transmitter.

ANT1: For connection of antenna or other load such as dummy load.

ANT2: Same as ANT1.

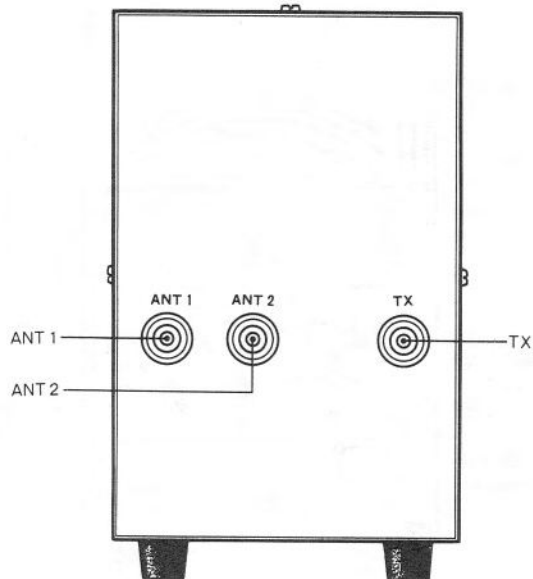

Fig. 5 Rear panel

CAUTIONS

1. Connect cables firmly to the TX and ANT connectors confirming the direction of connection.
2. PF-810 has 50-ohm of impedance and should be connected with 50-ohm cables. If it is to be connected to a device of different impedance (75-ohm, etc.), be sure to use a matching transformer or an antenna coupler.
3. Keep your hand off the internal circuit.
4. If SWR of load being used is unknown, the high frequency voltage of PF-810 may be increased excessively depending on the length of cable or the condition of load. In this case, adjust the power as small as possible for accurate impedance matching. When the impedance matching is completed, then set the transceiver for full power.
5. **Do not touch the antenna selector pushbutton while the transmitter is in operation. Be sure to turn off the power whenever the antenna selector is used.**

OPERATION

Connect a 50-ohm coaxial cable between the antenna terminal of the transceiver and the TX connector at the rear of PF-810, as shown in Fig. 6. Similarly, connect another 50-ohm coaxial cable between your antenna and the ANT1 or ANT2 connector. Two different antennas can be connected to PF-810. In either case, the antenna to be used should be selected by the antenna selector pushbutton.

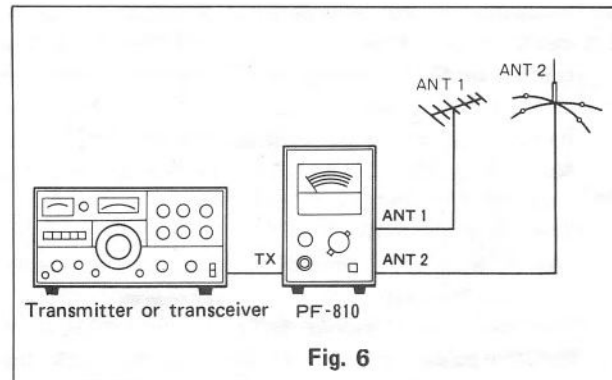

Fig. 6

1. Measurement of SWR

After the instrument has been connected as shown in Fig. 6 and the antenna has been selected, set the function switch to the CAL position and the calibration knob to the MIN position to start the transmitter in operation. If possible, adjust the power of

the transmitter to about 10W.

Turn the calibration knob clockwise until the meter pointer indicates the CAL position. Then, set the function switch to the SWR position and SWR will be indicated on the meter. Note that if the power of the transmitter is less than 1W, the meter cannot be set to the CAL position.

Also, when SWR is close to "1" during matching work, the meter pointer will deflect little, making it impossible to find the dip point of SWR. In this case, turn the calibration knob further clockwise until the meter pointer properly deflects so that the dip point can be obtained for easy matching of impedance. The reading of SWR obtained in this manner is incorrect because the calibration knob has been turned beyond its set point, so the meter should be calibrated again according to the abovementioned procedure after the completion of impedance matching.

The value of SWR measured on the meter varies slightly with the volume of power, since the detector diodes in the circuit have **non-linear characteristics**.

Normally, SWR should be calibrated at 10W of forward power. If the power is larger than 10W, the value of SWR on the meter will be a little higher than the actual value, and vice versa. Accurate SWR can be measured at 10W of forward power or by calculation after measuring forward power and refraction power as described below.

2. Measurement of forward power (FWD)

Connect the instrument as shown in Fig. 6. Set the

power range selector to the 150W position to prevent the meter pointer from scaling out. Set the function switch to the FWD position. With the transmitter operated, adjust the power range selector to the proper range and read forward power on the scale.

If a dummy load is connected to the ANT1 or ANT2, instead of connecting an antenna, the instrument functions as a terminal type power meter, allowing you to check the operating condition of the antenna being used by manipulating the antenna selector pushbutton. It is also useful for tuning the transmitter.

3. Measurement of refraction power (REF)

Set the instrument as described above except that the function switch should be positioned to REF. Refraction power will be read on the meter scale.

4. Calculation of SWR from forward power (P_f) and refraction power (P_r)

After the forward power (P_f) and refraction power (P_r) have been measured according to the procedures outlined in items 2 and 3 above, accurate SWR can be obtained from the following equation:

$$SWR = \frac{1 + \sqrt{\frac{P_r}{P_f}}}{1 - \sqrt{\frac{P_r}{P_f}}}$$

Actual SWR can also be obtained from the ratio of P_f to P_r on a graph (Fig. 7).

5. Measurement of radiant power (RAD)

In matching the impedance or monitoring the operating conditions of transmitter, both the forward power (P_f) and the reflection power (P_r) should be observed. If the reflection power (P_r) is extremely large (SWR of load is unusually high) while observing " P_f " alone, a large " P_f " is measured on the meter even when little power is consumed in the load. On the other hand, if only the " P_r " is observed, the meter indicates a smaller reflection power (P_r) when the output of transmitter is decreased due to some condition of the load being used, creating an illusion that the reflection power was very small. However, this can be eliminated by setting the function switch to

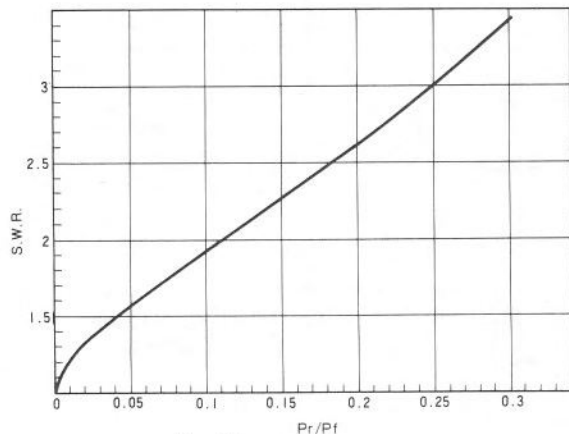

Fig. 7

the RAD position with PF-810 connected near to the load. In this way, the power ($P_f - P_r$) consumed in the load is indicated on the meter, which not only offers a convenience to impedance matching work but also allows you to monitor both the forward power and reflection power at the same time because the power measured is decreased as the reflection increases. Accordingly, when PF-810 is used as a monitor, the function switch is normally set to the RAD position. Even when PF-810 is connected near to the transmitter, the power measured on the meter can be regarded as a radiant power as long as the return loss of the transmitting system is disregarded. When the meter indicates a maximum radiant power (RAD), it means that the transmitter or the antenna coupler is properly adjusted.

6. Antenna selector

The antenna selector permits selection of antennas or dummy load. Two different antennas, such as 3.5/7-MHz 2-band dipole antenna and 14/21/28MHz 3-band Yagi antenna or HF band and 144MHz band antennas, can be connected to ANT1 and ANT2, respectively. A dummy load can also be connected to either ANT1 or ANT2, instead of connecting an antenna, for tuning or testing the transmitter.

By pressing the antenna selector pushbutton, ANT1 is connected to the instrument. By pressing the button once again, it is released and ANT2 is connected. **Note that the power of the transmitter should be turned off whenever the button is to be pressed.**

SCHEMATIC DIAGRAM

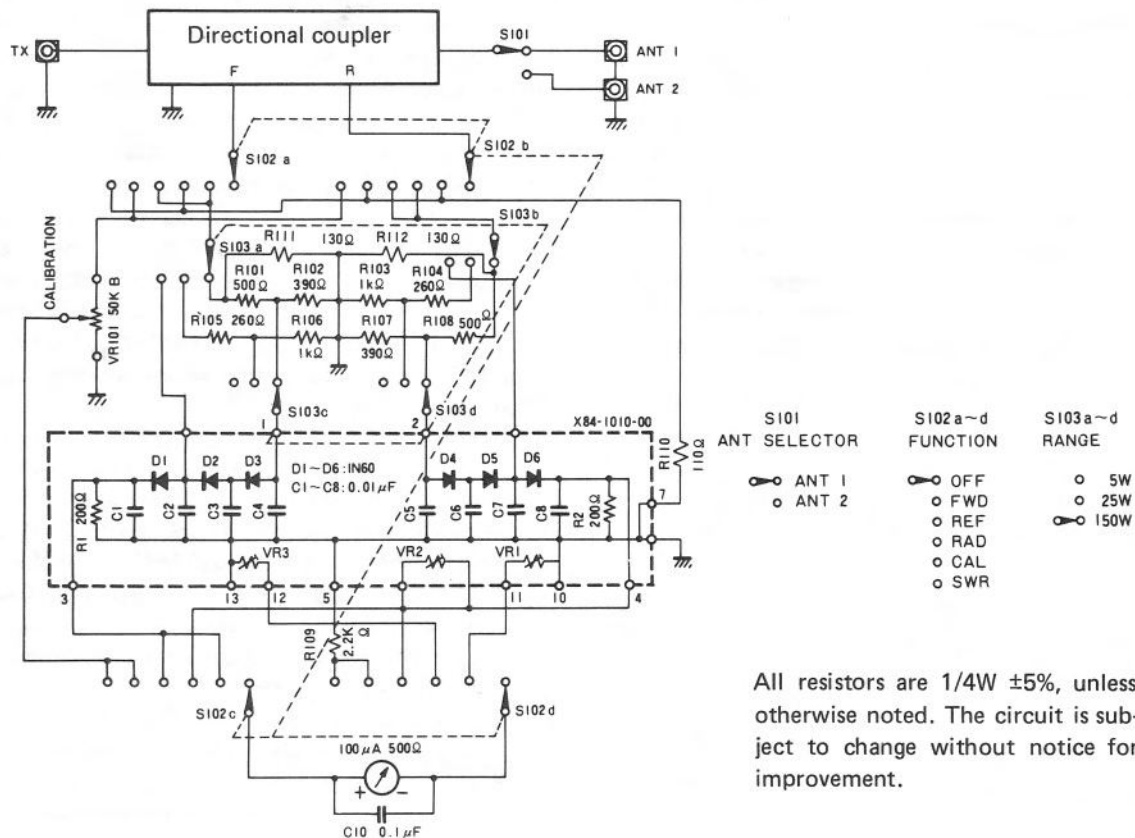

SMITH CHART

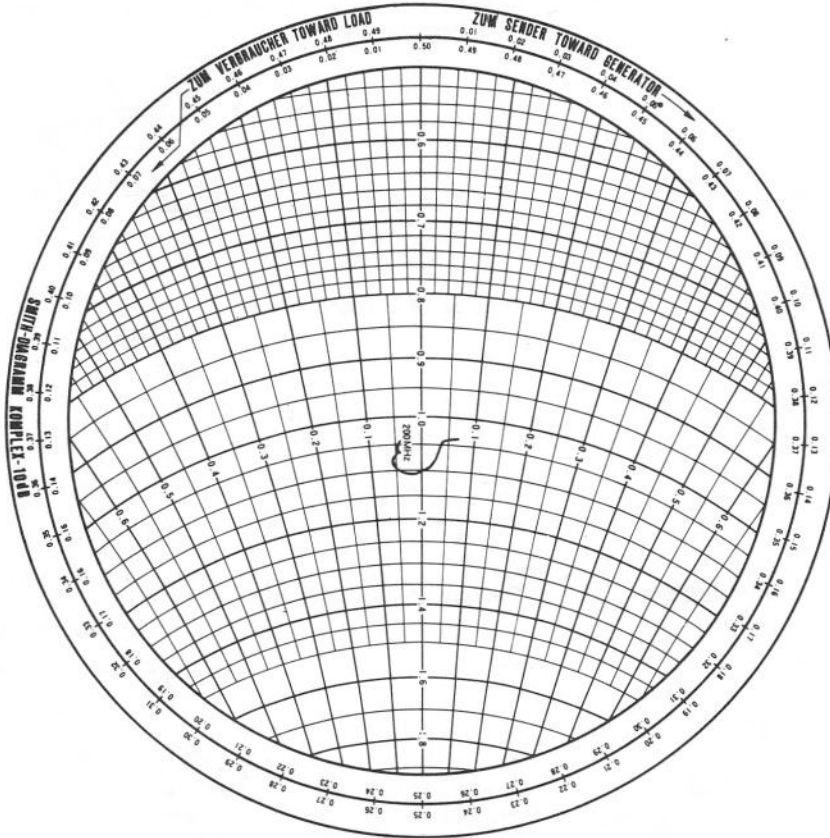

APPLICATIONS

**DX and local transmission
or quick QSY to other bands
with two antennas**

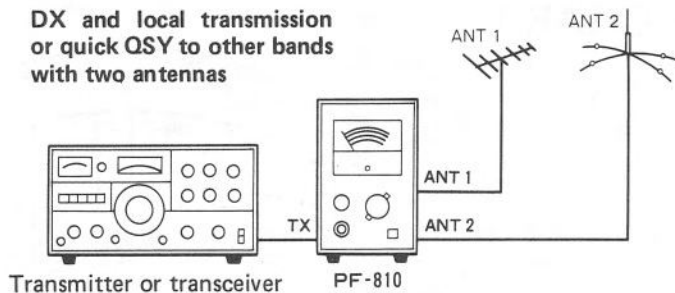

Tune-up of antenna and TX

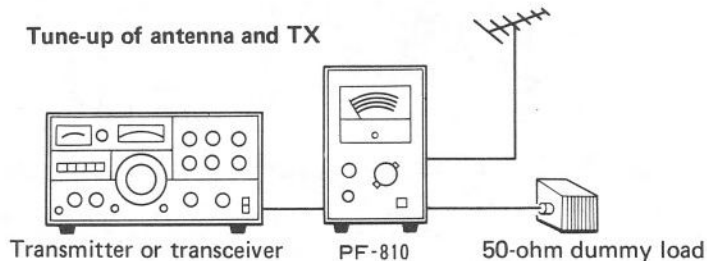

Tune-up of TX or antenna coupler

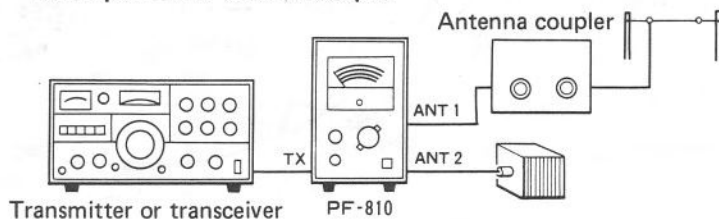

Tune-up of TX and antenna coupler

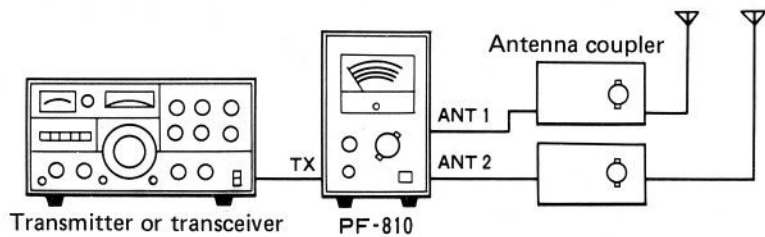

Observation and adjustment of sending waveforms with monitor-scope

