

REVISED EDITION

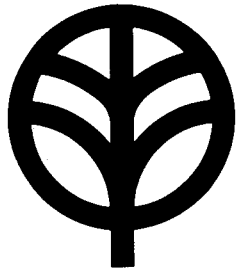

KENWOOD

SERVICE MANUAL

Model TR-9000

PS-20 BO-9



CONTENTS

BLOCK DIAGRAM	2	TX Unit (X56-1360-XX)	17
CIRCUIT DESCRIPTION	3	PARTS LIST	18
OUTSIDE VIEWS	9	PACKING	26
PC BOARD/CIRCUIT DIAGRAM		DISASSEMBLY	26
Switch Unit (X41-1290-11)	10	REFERENCE DATA	30
Final Unit (X45-1140-XX)	10	PS-20	31
Carrier Unit (X50-1630-11)	11	SYSTEM BASE BO-9	33
SIDE TONE Unit (X52-1140-10)	11	LEVEL DIAGRAM	34
MODE, MEMORY, SCAN, TX OFF SET, PC Board	11	ADJUSTMENTS	35
PLL Unit (X50-1620-XX)	12	WIRE HARNESS	42
Control Unit (X53-1160-XX)	14	SCHEMATIC DIAGRAM	43
RX Unit (X55-1260-XX)	16	SPECIFICATIONS	BACK COVER

2m ALL MODE TRANSCEIVER

BLOCK DIAGRAM (K)

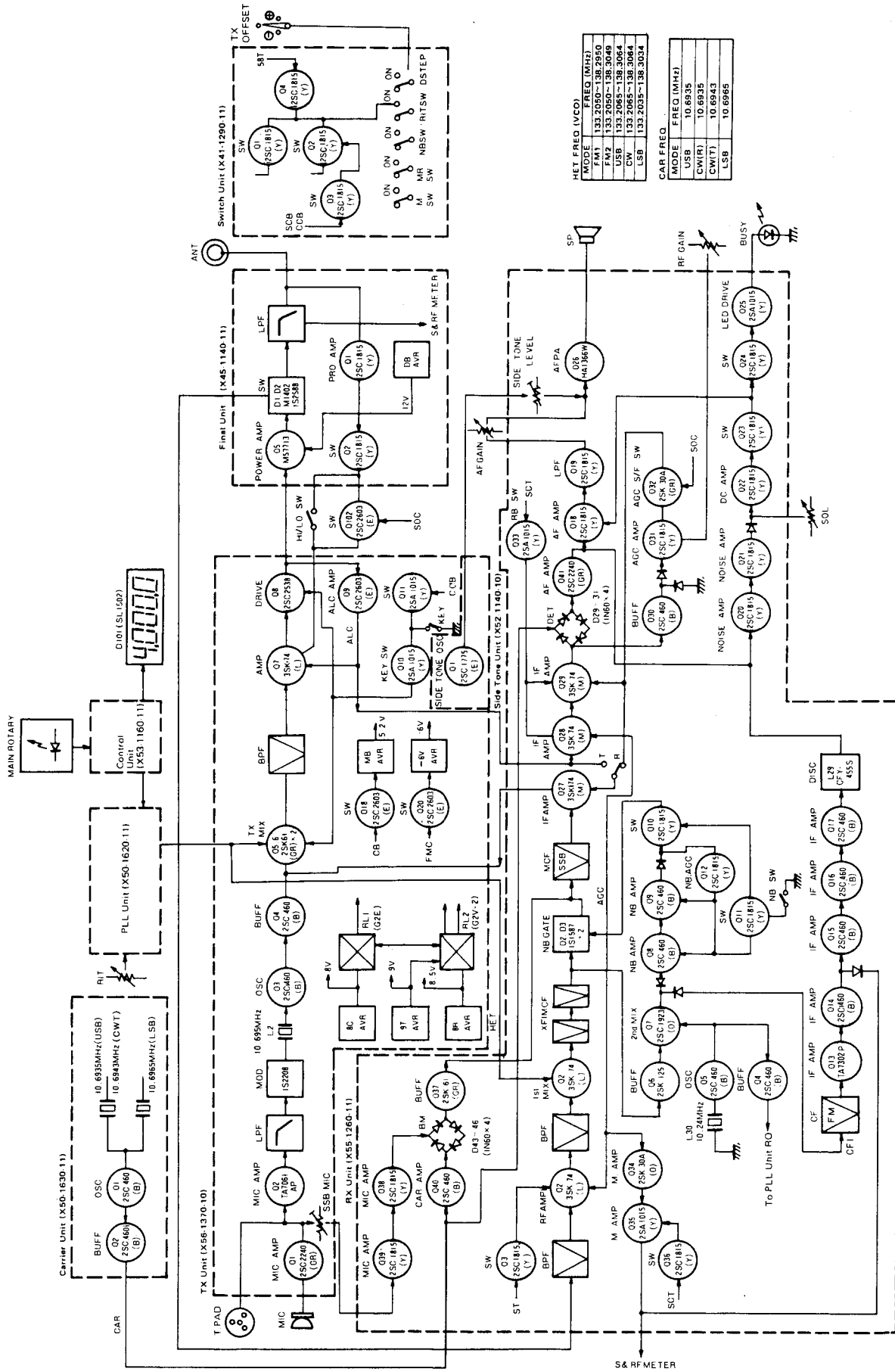

MET FREQ (VCO)	MET FREQ (MHz)
FM1	133.2050-138.2050
FM2	133.2050-138.3064
USB	133.2065-138.3064
CW	133.2065-138.3064
LSB	133.2035-138.3034

CAR FREQ	FREQ (MHz)
USB	10.6935
CW(R)	10.6935
CW(T)	10.6943
LSB	10.6965

CIRCUIT DESCRIPTION

RX Section

The front end unit is comprised of a dual gate MOS FET and helical resonator. The 2-stage MCF (Monolithic Crystal Filter) following the 1st mixer Q2 (3SK74) provides excellent 2-signal characteristic and high sensitivity.

The IF signal from the MCF is divided and applied to the SSB and FM circuits. The SSB signal passes through the NB (Noise Blanker) gate crystal filter (10H2.2SD) and is amplified by the transmit/receive IF amplifier, Q27, Q28 and 29, and is then demodulated into an audio signal by the product detector.

In the NB circuit, the signal from the MCF passes through the buffer amplifier Q6 and is fed to the 2nd mixer Q7. This signal is converted 455 kHz and the noise is amplified by two stages for switching the NB gate. The NB is front panel controlled.

In the AGC circuit, the signal from the final IF stage is detected and amplified, and the time constant is automatically select according to the mode of operation, FAST in CW mode and SLOW in SSB mode. The AGC signal is applied to the 3-stage IF amplifier, Q27, 28 and 29 (3SK74), and the RF amplifier Q1. The AGC voltage is also used for meter indication.

In the FM circuit, the signal from the ceramic filter CFW-455E is amplified by the IF amplifier Q13 (TA7302P). The auto scan stop signal is applied to the micro-computer from the squelch circuit.

The detected AF signal is amplified by the AF amplifier Q18, a 2SC1815(Y). The amplified signal passes through the LPF (Low Pass Filter) Q19, a 2SC1815(Y) and is power-amplified by Q26, (HA1366W) via the AF GAIN control to drive the speaker.

Item	Symbol	Condition (Ta = 25°C)	Rating			Unit
			MIN	TYP	MAX	
DC current with no input	I _d	V _{in} = 0	—	30.0	60.0	mA
Gain in voltage	G _v	V _{in} = -50 dB	50.0	52.5	55.0	dB
Output power	P _o	THD = 10%	4.5	5.5	—	W
Distortion	THD	P _o = 0.5W	—	—	1.5	%
Noise level	WBN	R _g = 10 kΩ, BW = 20 Hz ~ 20 kHz	—	—	2.0	mV
Hum ratio	HR	f = 500 Hz	28.0	—	—	dB
Voltage allowance with a shorted load		f = 500 Hz, V _{in} = 10 mV, t = 5 sec.	16.0	—	—	V

Rank	1	2	3
G _v (dB)	50.0 ~ 52.2	51.4 ~ 53.6	52.8 ~ 55.0

Table 1. HA1366W (RX Unit : Q26)

Item	Rating
Nominal center frequency	455 kHz
6 dB bandwidth	±7.5 kHz or more
50 dB bandwidth	±15 kHz or less
Ripple (within 455 ±5 kHz)	3 dB or less
Loss	6 dB or less
Guaranteed attenuation (within 455 ±100 kHz)	35 dB or more
Input and output impedance	1.5 kΩ

Table 2. Ceramic filter (L72-0316-05) CFW455E (RX Unit : CF1)

Item	Rating
Nominal center frequency (f _o)	10.695 MHz
Center frequency	Within f _o ±200 Hz at 6 dB
Pass bandwidth	2.2 kHz or less at 6 dB
Attenuation bandwidth	±1.5 kHz or less at 20 dB ±2.4 kHz or less at 60 dB
Ripple	Less than 2 dB
Loss	Less than 5 dB
Guaranteed attenuation	60 dB or more within ±40 kHz
Input and output impedance	600Ω ±10%/15 pF ±10%

Table 3. Crystal filter (L71-0215-05) 10H2.2SD (RX Unit : XF2)

Item	Rating
Nominal center frequency (f _o)	10.695 MHz
Pass bandwidth	±7.5 kHz or more at 3 dB
Attenuation bandwidth	±25 kHz or less at 40 dB ±45 kHz or less at 60 dB
Guaranteed attenuation	1. 70 dB or more within ±1 MHz 2. Spurious level = 40 dB or more at f _o ~ f _o + 500 kHz 3. Spurious level = 80 dB or more at f _o - (910 kHz ±10 kHz)
Ripple	1.0 dB or less
Loss	1.5 dB or less
Impedance	3 kΩ/0 pF

Table 4. MCF (L71-0216-05) (RX Unit : XF1)

TX Section

The microphone signal is amplified by the SSB/FM microphone amplifier Q1, a 2SC2240 (GR). This signal is then divided and fed to the SSB and FM circuits. SSB signal passes through the MIC GAIN control and is fed to the RX

CIRCUIT DESCRIPTION

unit where the signal is amplified by two stages and is then applied to the balanced modulator together with the carrier signal (10.695 MHz). The DSB (Double Side Band) signal from the buffer amplifier Q37, a 2SK61 (GR) is fed to the transmit/receive crystal filter to produce an SSB signal. This signal is amplified and applied to the transmit balanced mixer, Q5 and Q6, 2SK61 (GR), in the TX unit. The FM signal is limiter-amplified by Q2 (TA7061AP) and is directly modulated by a 1S2208 diode. The modulated signal is applied to the mixer through the oscillator circuit Q3 (10.695 MHz) and buffer amplifier Q4 a 2SC460 (B). The remaining circuits are common to all the operating modes. The 4-stage BPF (Band Pass Filter) next to the mixer is used to eliminate unwanted spurious signals. After filtering, the signal is amplified by Q7, a 3SK74 (L) to drive the final unit via Q8 (2SC2538).

In the ALC circuit, the drive output from Q8 is amplified by Q9, a 2SC2603 (E) and is applied to the 2nd gates of the predriver Q7 and IF amplifier Q27.

The HI/LOW selection and protection in the FM and CW modes is accomplished by changing the source voltage of Q7, the predriver. In CW mode, the keying circuit controls the transmit balanced mixer B+ line and the base circuit of the predriver Q8 by the switching action of Q10, a 2SC1015 (Y). This signal, fed to the final unit, is power-amplified by the power module (M57713), and is then output to the antenna through, the LPF (Low Pass Filter). The M57713 is designed to provide excellent power, idle current, IMD and "f" characteristics, thus insuring stabilized performance.

Item	Symbol	Tc (°C)	Rating
Operating voltage	Vcc	25	17V
DC current	Icc	25	6A
Operating case temperature	Tc (op)	—	-30 ~ +110°C
Storage temperature	Tstg	—	-40 ~ +110°C
Base bias voltage	Vbb	25	10V

Table 5. Power module (V30-1131-06) M57713 MAX Rating (Final Unit : Q5)

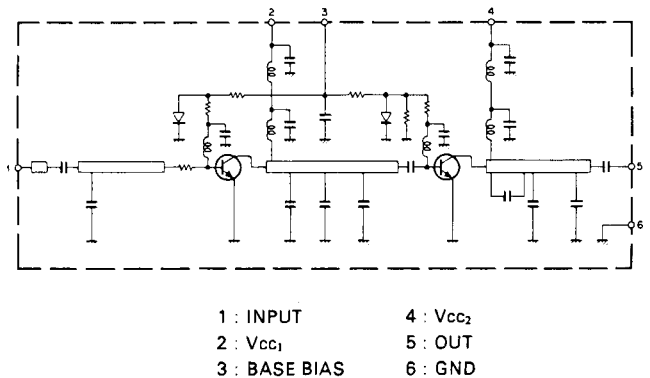
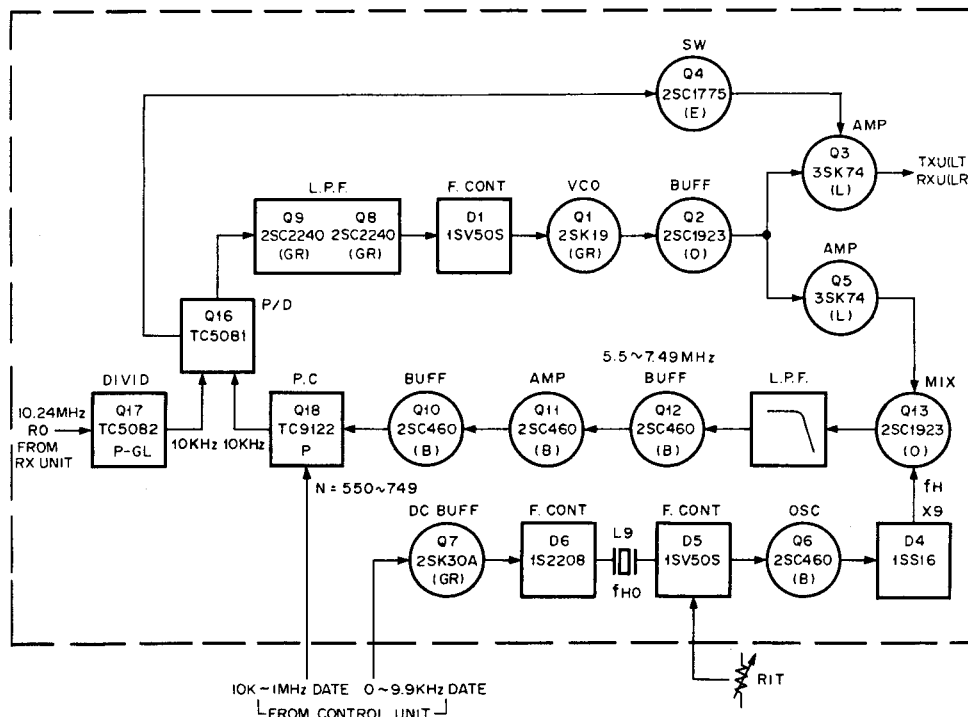

Fig. 1 Power module (V30-1131-06) Equivalent Circuit

PLL Unit (X50-1620-11)



VCO FREQ

MODE	FREQ (MHz)
FM1	133.305 ~ 135.285
FM2	133.305 ~ 135.3049
USB	133.3065
CW	~ 135.3064
LSB	133.3035 ~ 135.3034

HET OSC FREQ fH0

MODE	FREQ (MHz)
FM1	14.20055
FM2	14.20055 ~ 14.20165
USB	14.20072
CW	~ 14.20182
LSB	14.20039 ~ 14.20149

PLL HET FREQ fH

MODE	FREQ (MHz)
FM1	127.805
FM2	127.805 ~ 127.8149
USB	127.8065
CW	~ 127.8164
LSB	127.8035 ~ 127.8134

Fig. 2 PLL Unit Block Diagram

CIRCUIT DESCRIPTION

PLL Unit (X50-1620-11)

Fig. 2 shows a basic block diagram of PLL circuit. The signal from the VCO (Q1, a 2SK19 (GR)) passes through the buffer amplifier formed by Q2, a 2SC1923 (O) and Q5, a 3SK74 (L), and is then mixed with the HET (Heterodyne) signal by Q13, a 2SC1923 (O) to produce 5.5 ~ 7.49 MHz signal. This signal is amplified by Q10, 11 and Q12, 2SC460 (B) and is frequency-divided by Q18 (TC9122P) according to the BCD data (MHz, 100 kHz and 10 kHz order) from the control unit, to produce 10 kHz comparison signal. Simultaneously, the 10.24 MHz signal from the RX unit is frequency-divided to 1/1024 by Q17 (TC5082P-GL) to produce 10 kHz reference signal. These signals are phase-compared by Q16 (TC5081P) and fed to the LPF formed by Q8 and Q9, and the resulting control voltage is applied to the VCO vari-cap tuning diode.

The 14.2 MHz VCO HET signal is generated by crystal oscillator Q6, a 2SC460 (B), and is then multiplied 9 times by D4 (1SS16) to produce a 127.8 MHz signal. This signal is then applied to the mixer, Q13, a 2SC1923 (O).

The crystal oscillator circuit has two vari-cap diodes to control frequency. A DC signal, corresponding to 0 ~ 9.9 kHz produced by the control unit (X53-1160-00), is voltage converted by Q7, a 2SK30A (GR) and is fed to the vari-cap D6 (1S2208) to control the frequency. The other vari-cap D5 (1SV50S) is used to shift the frequency ($f_{USB} = f_{FM} + 1.5$ kHz, $f_{LSB} = f_{FM} - 1.5$ kHz) according to the operating mode and to afford RIT (Receive Incremental Tuning) frequency.

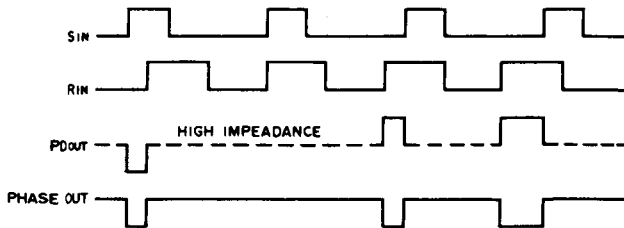

Fig. 3 TC5081P (PLL Unit : Q16)
Phase comparator timing chart

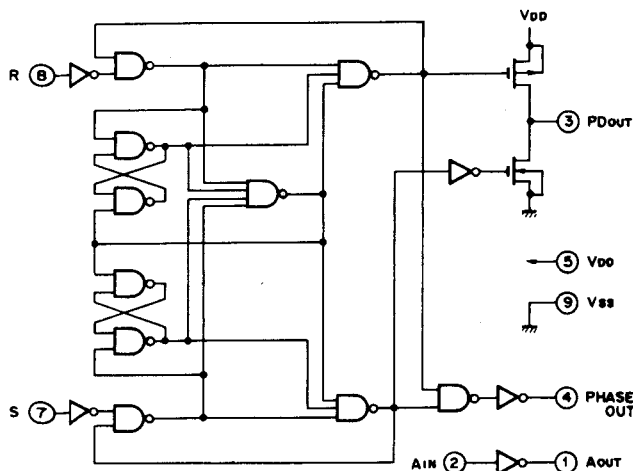

Fig. 4 TC5081P (PLL Unit : Q16)

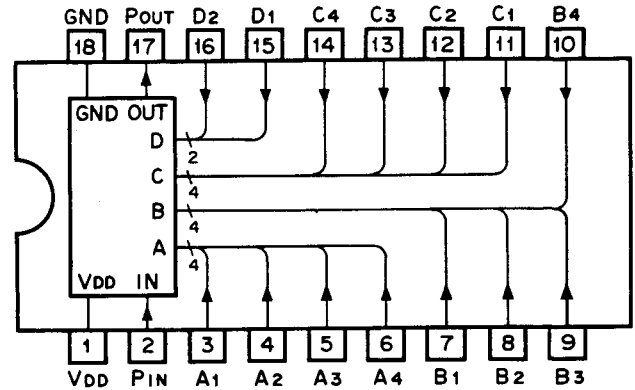

Fig. 5 TC9122P (PLL Unit : Q18)

Symbol	Name	Content and operation	Remarks																																																																																																																
Pin	Programmable counter input terminal	Programmable counter input terminal to which the signal to be divided is input.	Built-in bias circuit																																																																																																																
Pout	Programmable counter output terminal	Programmable counter output terminal. Output is 1/N of the input frequency. The output pulse width equals 5 bit of the input.																																																																																																																	
A ₁ ~A ₄ B ₁ ~B ₄ C ₁ ~C ₄ D ₁ ~D ₄	Program input terminals × 1 × 10 × 100 × 1000	Terminal to set the dividing ratio. The following input combination is prohibited.	Built-in pull-down resistor																																																																																																																
		<table border="1"> <tr> <td>A₁</td><td>A₂</td><td>A₃</td><td>A₄</td><td>B₁</td><td>B₂</td><td>B₃</td><td>B₄</td><td>C₁</td><td>C₂</td><td>C₃</td><td>C₄</td><td>D₁</td><td>D₂</td><td>D₃</td><td>D₄</td> </tr> <tr> <td>1</td><td>0</td><td>0</td><td>0</td><td>0</td><td>0</td><td>0</td><td>0</td><td>0</td><td>0</td><td>0</td><td>0</td><td>0</td><td>0</td><td>0</td><td>0</td> </tr> <tr> <td>0</td><td>1</td><td>0</td><td>0</td><td>0</td><td>0</td><td>0</td><td>0</td><td>0</td><td>0</td><td>0</td><td>0</td><td>0</td><td>0</td><td>0</td><td>0</td> </tr> <tr> <td>0</td><td>0</td><td>1</td><td>0</td><td>0</td><td>0</td><td>0</td><td>0</td><td>0</td><td>0</td><td>0</td><td>0</td><td>0</td><td>0</td><td>0</td><td>0</td> </tr> <tr> <td>1</td><td>0</td><td>1</td><td>0</td><td>0</td><td>0</td><td>0</td><td>0</td><td>0</td><td>0</td><td>0</td><td>0</td><td>0</td><td>0</td><td>0</td><td>0</td> </tr> <tr> <td>0</td><td>1</td><td>1</td><td>0</td><td>0</td><td>0</td><td>0</td><td>0</td><td>0</td><td>0</td><td>0</td><td>0</td><td>0</td><td>0</td><td>0</td><td>0</td> </tr> <tr> <td>1</td><td>1</td><td>1</td><td>0</td><td>0</td><td>0</td><td>0</td><td>0</td><td>0</td><td>0</td><td>0</td><td>0</td><td>0</td><td>0</td><td>0</td><td>0</td> </tr> </table>	A ₁	A ₂	A ₃	A ₄	B ₁	B ₂	B ₃	B ₄	C ₁	C ₂	C ₃	C ₄	D ₁	D ₂	D ₃	D ₄	1	0	0	0	0	0	0	0	0	0	0	0	0	0	0	0	0	1	0	0	0	0	0	0	0	0	0	0	0	0	0	0	0	0	1	0	0	0	0	0	0	0	0	0	0	0	0	0	1	0	1	0	0	0	0	0	0	0	0	0	0	0	0	0	0	1	1	0	0	0	0	0	0	0	0	0	0	0	0	0	1	1	1	0	0	0	0	0	0	0	0	0	0	0	0	0	
A ₁	A ₂	A ₃	A ₄	B ₁	B ₂	B ₃	B ₄	C ₁	C ₂	C ₃	C ₄	D ₁	D ₂	D ₃	D ₄																																																																																																				
1	0	0	0	0	0	0	0	0	0	0	0	0	0	0	0																																																																																																				
0	1	0	0	0	0	0	0	0	0	0	0	0	0	0	0																																																																																																				
0	0	1	0	0	0	0	0	0	0	0	0	0	0	0	0																																																																																																				
1	0	1	0	0	0	0	0	0	0	0	0	0	0	0	0																																																																																																				
0	1	1	0	0	0	0	0	0	0	0	0	0	0	0	0																																																																																																				
1	1	1	0	0	0	0	0	0	0	0	0	0	0	0	0																																																																																																				

Table 6. Functions of TC 9122P (PLL Unit : Q18)

CONTROL Unit (X53-1160-11)

Fig. 8 shows the basic configuration of control unit. Utilizing the micro-computer to its full advantage, this control circuit has been designed for a minimum of peripheral control circuits.

- Indicator

The indicator is a dynamic lighting (scanning) type, using 5-digit LED's. The BCD code data available at the micro-computer D port (pins 8-11) is converted into 7-segment data by the decoder driver Q18 (TC522BP), so that transistors Q5-9, 2SC1815 (Y) are switched (scanned) in sequence by the digit signal from the E and F ports (pins 12-16) and light the LEDs.

- PLL Data Output

The PLL MHz, 100 kHz and 10 kHz order data outputs are available directly from the BCD code at the G, H and I ports (pins 22-32). For the 1 kHz and 100 Hz order data, only the indicator data (1 kHz and 100 Hz order) are stored in the dual latch, Q16 (MN1201A) to produce the data for each digit.

This 2-digit data is converted to a corresponding DC voltage by the D/A converter, a combination of solid resistors (R6-20).

The MHz, 100 kHz and 10 kHz order data are 550 at 4.00, 650 at 5.00 and 749 at 5.99, respectively (3-digit BCD code).

- Reset Circuit

The reset circuit is a voltage detecting type. When the source voltage of the micro-computer is increased and exceeds about 3.5V, a current flows into D20, causing Q11,

CIRCUIT DESCRIPTION

a 2SC1815 (Y) to turn ON, which in turn sets the collector of Q10, a 2SC1815 (Y) high, and a reset pulse is input to the micro-computer through the CR differentiation circuit.

- Encoder and UP/DOWN Inputs

Fig. 7 shows the output signal from the encoder # (50 steps per rotation). This signal is used to discriminate UP and DOWN counts within the micro-computer. The UP count starts when U/D is H level at the down edge of the clock signal, and the DOWN count when U/D is L level.

- Tone Oscillator Circuit

When the output for the micro-computer tone oscillator is H level, Q12, a 2SC1815 (Y) is energized, allowing a current to flow into the piezo-electric buzzer oscillator, Q13, a 2SC1815 (Y), producing a tone.

- Switching Circuit

Each of the switches in the control unit are used to select the control pulses output from the micro-computer. Fig. 8 shows a block diagram of the control unit. For actual operation of this unit, the micro-computer input and output terminals must be connected. The diodes (see circuit diagram) are used to prevent control pulses from entering the wrong circuits.

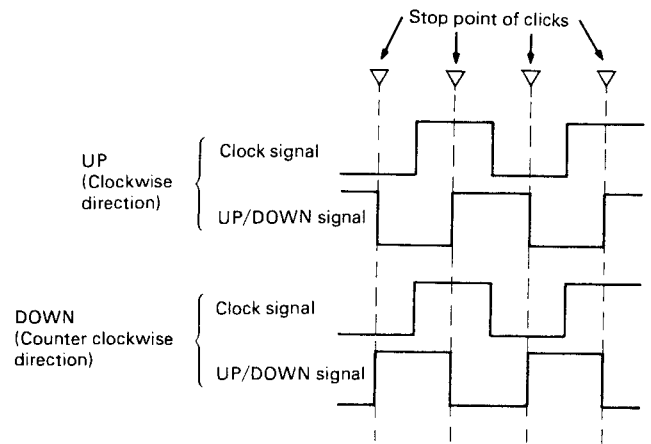

Fig. 6

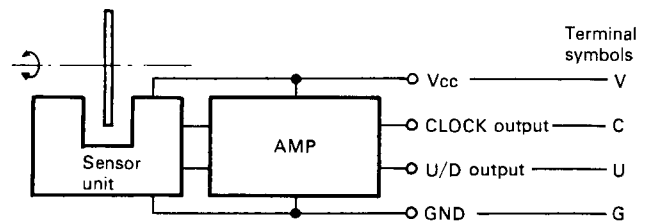

Fig. 7 Rotary encoder (W02-0308-05)

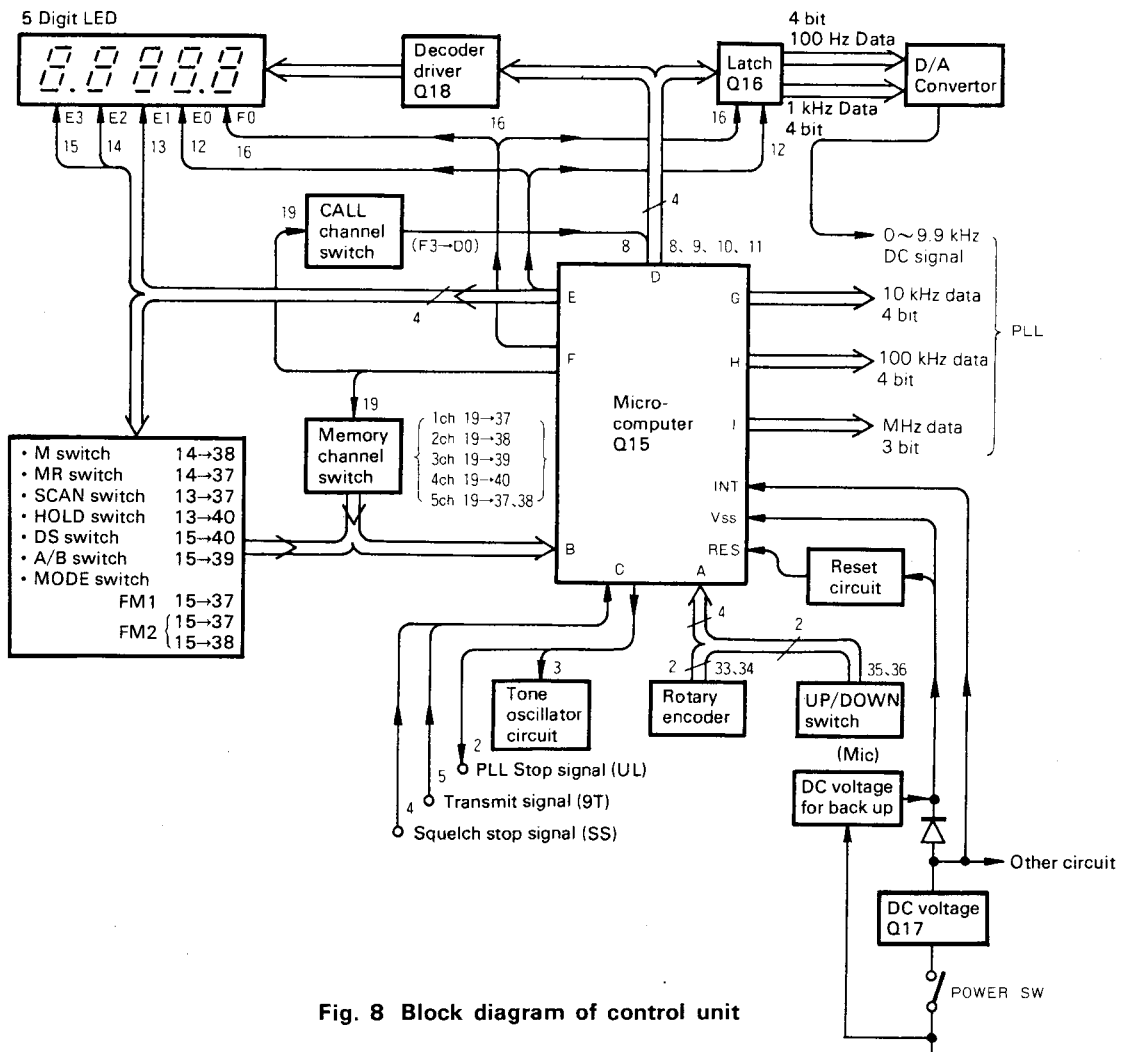

Fig. 8 Block diagram of control unit

CIRCUIT DESCRIPTION

● Scan Circuit

This circuit is active when the SCAN switch is depressed. During operation, counting and all other functions are effected within the micro-computer. The scan stops by pressing the HOLD switch or by setting the transmit signal (9T) to H level. The scan stops for a brief period of time when the squelch stop signal (SS terminal) becomes H level. This signal is used to stop the scan in 10 kHz or 20 kHz step. The changes in the 10 kHz PLL data each are differentiated as is or are inverted by Q19, 20 to obtain OR data so that pulses are output each time the data is changed. These pulses are applied to the micro-computer scan stop terminal (4) to slow down the scan operation.

● Control Power Circuit

The indicator operates on 5V available at transistor Q14, a 2SC496 (Y). The micro-computer operates on 6V supplied by the AVR (Automatic Voltage Regulator) IC, Q17 (NJM78L06K), supplied through a reverse current blocking diode, D11.

● Backup Circuit

When the POWER SW is turned OFF, the micro-computer operates from the backup power source when the micro-computer INT terminal (pin 6) is at L level. At this time, all

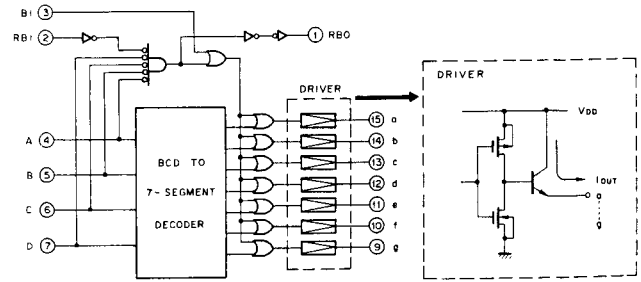

Fig. 9 TC5022BP (Control unit : Q18)

INPUT		OUTPUT												
B1	RB1	A	B	C	D	a	b	c	d	e	f	g	h	
H	*	*	*	*	*	L	L	L	L	L	L	L	L	☆
L	H	L	L	L	L	L	L	L	L	L	L	L	L	H
L	L	L	L	L	L	H	H	H	H	H	H	L	L	L
L	*	H	L	L	L	L	L	H	L	L	L	L	L	L
L	*	L	H	L	L	H	H	L	H	H	L	H	L	L
L	*	H	H	L	L	H	H	L	H	H	L	L	H	L
L	*	L	L	H	L	L	H	H	L	L	H	H	L	L
L	*	H	L	H	L	H	L	H	H	L	H	H	L	L
L	*	L	H	H	L	H	L	H	H	L	H	H	L	L
L	*	H	H	H	L	H	H	L	L	L	L	L	L	L
L	*	L	L	L	L	H	H	H	H	H	H	H	L	L
L	*	H	L	L	H	H	H	H	H	L	H	H	L	L
L	*	L	H	L	H	H	H	H	H	L	H	H	L	L
L	*	H	H	L	H	L	H	H	L	L	L	L	L	L
L	*	L	L	L	H	H	H	L	H	H	L	L	H	L
L	*	H	L	H	H	H	H	H	L	L	L	L	H	L
L	*	L	H	H	H	L	H	H	L	L	H	H	L	L
L	*	H	H	H	H	H	L	H	L	H	H	L	L	L

Table 8 Truth table of TC5022BP (Control unit : Q18)
 ☆ Undetermined * Don't Care

Pin No.	Pin	Input signal	Output signal	Description	Pulse
1	CL1			Clock signal 400 kHz	
2	PC0	○		Normally L, H at prohibited transmitting	
3	PC1	○		Normally L, H at Tone ON	
4	PC2	○		Squelch signal, H at Busy stop	
5	PC3	○		Normally L, H at transmit	
6	INT	○		Normally H	
7	RES	○		H at reset	
8	PD0	○	○	Call channel input signal. 100 Hz, 1 kHz order data output.	○
9	PD1		○		○
10	PD2		○		○
11	PD3		○		○
12	PE0		○	1 kHz order data output, latch pulse	○
13	PE1		○	10 kHz order data output SCAN, HOLD output	○
14	PE2		○	100 kHz order data output M, MR output	○
15	PE3		○	1 MHz order data output DS, A/B, MODE output	○
16	PF0		○	100 Hz order data output Latch pulse	○
17	PF1		○	Not used (open)	
18	PF2		○	Not used (open)	
19	PF3		○	CALL, MEMORY output	○
20	TEST	○		Normally H	
21	Vcc	○		5V DC supply	

Table 7. Functions of μPD650C-021 (Control Unit: Q15)

Pin No.	Pin	Input signal	Output signal	Description	Pulse	
22	PG0		○	A } 10 kHz order data output for PLL		
23	PG1		○		B } 100 kHz order data output for PLL	
24	PG2		○			C } MHz order data output for PLL
25	PG3		○		D } MHz order data output for PLL	
26	PH0		○	A } MHz order data output for PLL		
27	PH1		○		B } MHz order data output for PLL	
28	PH2		○			C } MHz order data output for PLL
29	PH3		○		D } MHz order data output for PLL	
30	PI0		○	A } MHz order data output for PLL		
31	PI1		○		B } MHz order data output for PLL	
32	PI2		○			C } MHz order data output for PLL
33	PA0	○		Encoder input, clock		
34	PA1	○		Encoder input, UP/DOWN		
35	PA2	○		Normally H, L at MIC UP operation		
36	PA3	○		Normally H, L at MIC DOWN operation		
37	PB0	○		MR, SCAN, MODE-FM1, MEMORY 1, 5CH pulse input	○	
38	PB1	○		M, MODE-FM2, MEMORY 2, 5CH pulse input	○	
39	PB2	○		VFO-B, MEMORY 3CH pulse input	○	
40	PB3	○		SEARCH, MEMORY, 4CH pulse input	○	
41	Vss			Grounded		
42	CLO			Clock signal 400 kHz		

CIRCUIT DESCRIPTION

output ports become L level, minimizing power consumption. When the POWER SW is turned ON, the INT terminal and UP/DOWN input terminal become H level, and the micro-computer resumes at its original condition. The input port B (pins 37-40) is momentarily set to L level by Q2 and Q4 to insure backup operation even when other switches remain ON. Backup operation is also assured during scan operation, since the scan is stopped by Q3 when the POWER SW is turned OFF.

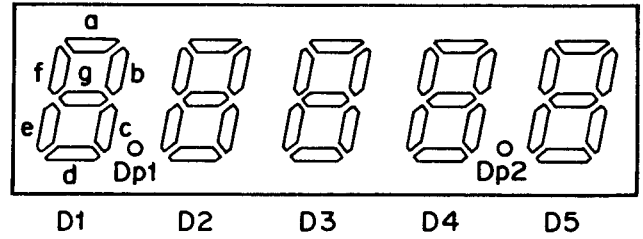

Symbol	Pin	Description
IN1 ~ IN4	Input	4-bit input terminal
AO1 ~ AO4	Output	Output terminal for data latched by clock pulse CKA
BO1 ~ BO4	Output	Output terminal for data latched by clock pulse CKB
CKA	Clock A	Clock signal terminal for latching 4-bit input signal in 4-bit flip flop A. Input signal is latched at the rising of clock signal.
CKB	Clock B	Clock signal terminal for latching 4-bit input signal in 4-bit flip flop B. Input signal is latched at the rising of clock signal.

Pin No.	Address	Pin No.	Address
1	D5, Dp2 Cathode	9	e Anode
2	D4 Cathode	10	d Anode
3	D3 Cathode	11	c Anode
4	D2 Cathode	12	g Anode
5	D1, Dp1 Cathode	13	b Anode
6	Open	14	a Anode
7	Dp1, Dp2 Anode	15	f Anode
8	Dp1, Dp2 Anode		

Table 9. Function of MN 1201A (Control Unit : Q16)

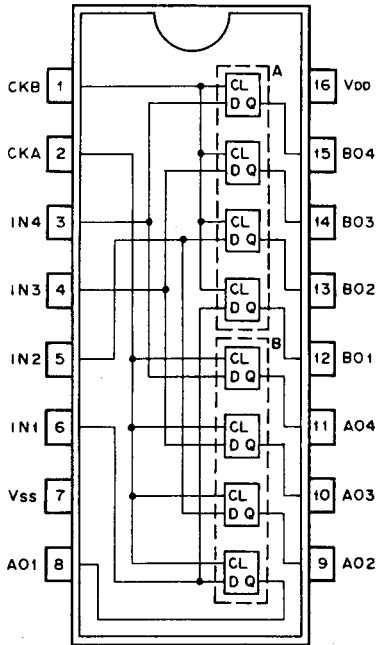

Fig. 10 MN1201A (Control unit : Q16)

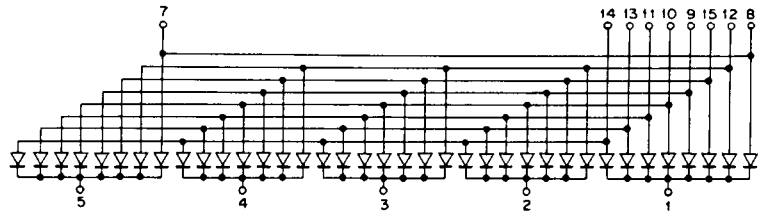
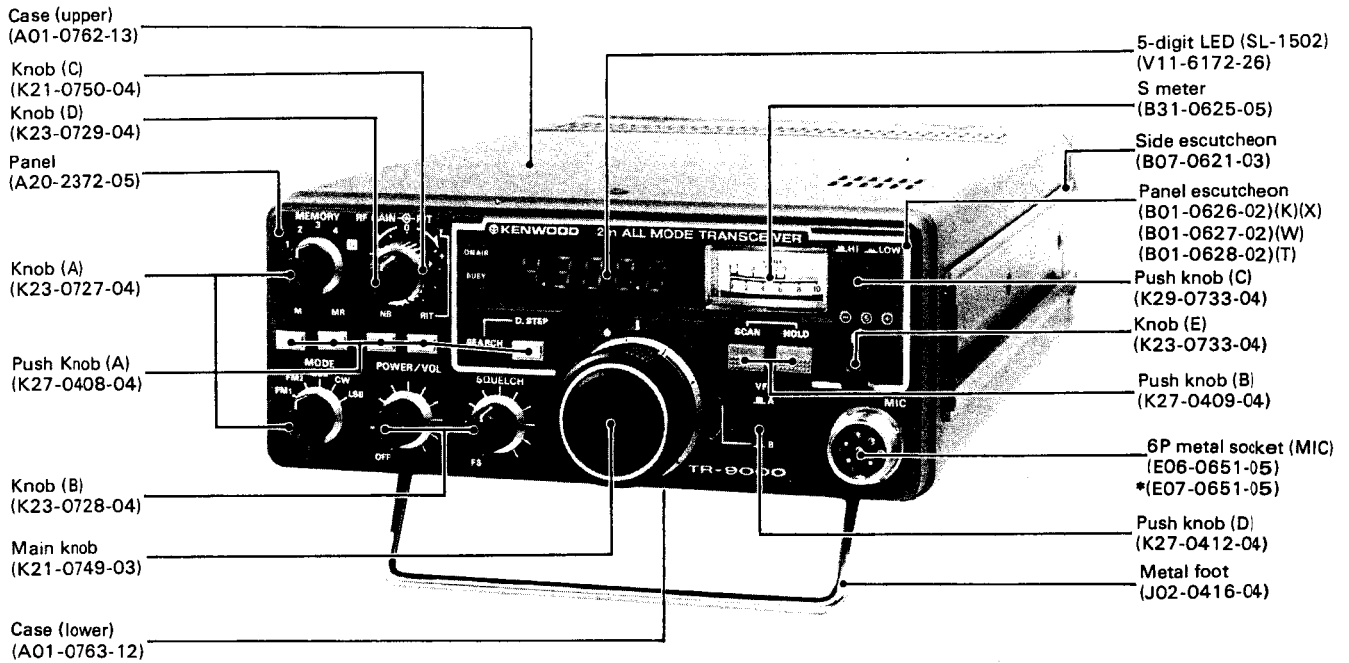

Fig. 11 5 digit LED D101 : SL1502

OUTSIDE VIEWS

< FRONT PANEL > TR-9000 (K)



* Mating connector

< REAR PANEL > TR-9000 (K)

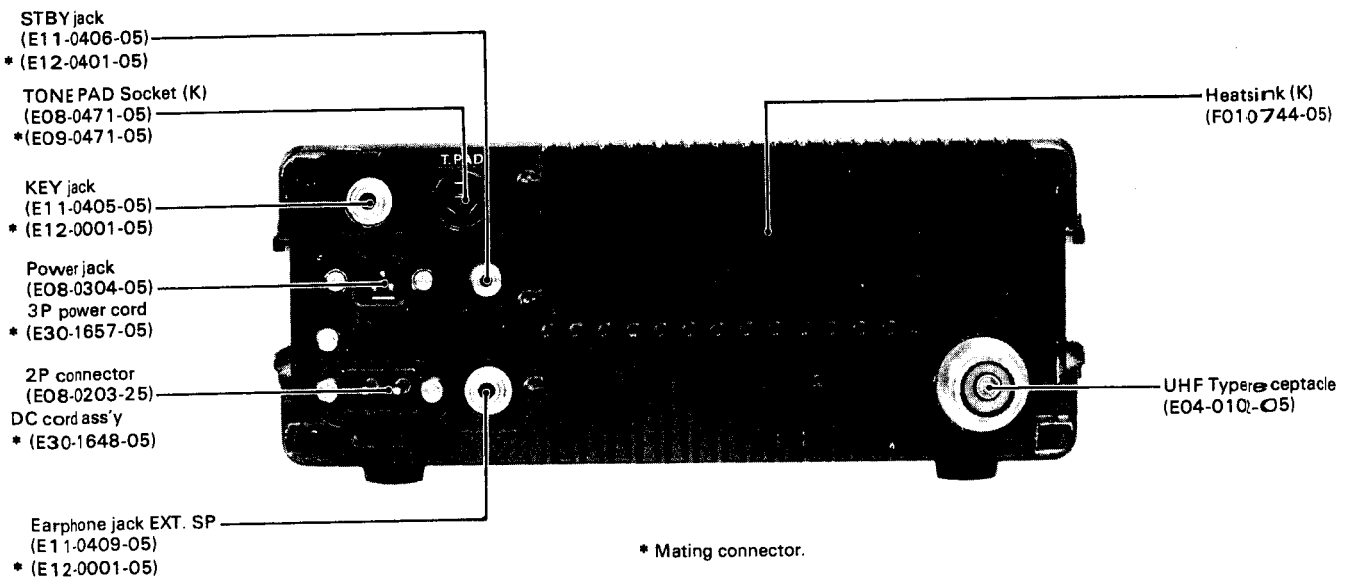

* Mating connector.

PC BOARD VIEWS

▼ SWITCH UNIT (X41-1290-11) PARTS LIST: Page 19

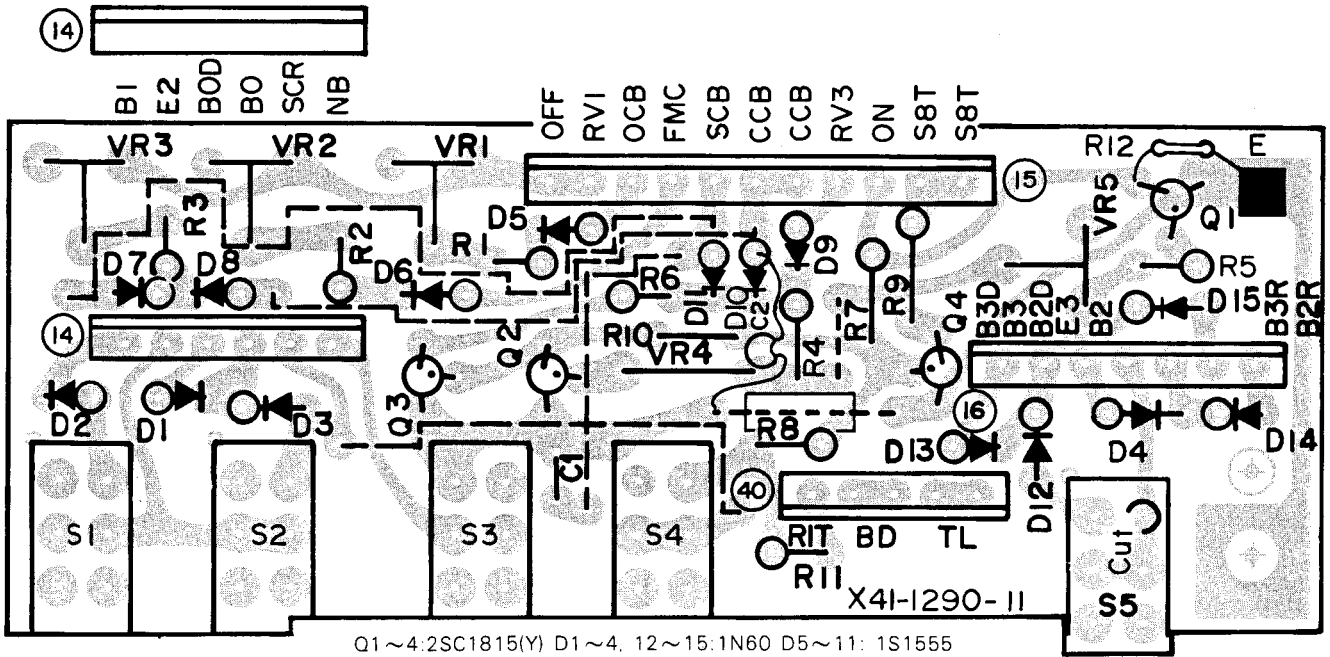

▼ FINAL UNIT (X45-1140-00) (W)(T)(X) PARTS LIST: Page 20 (X45-1140-11) (K)

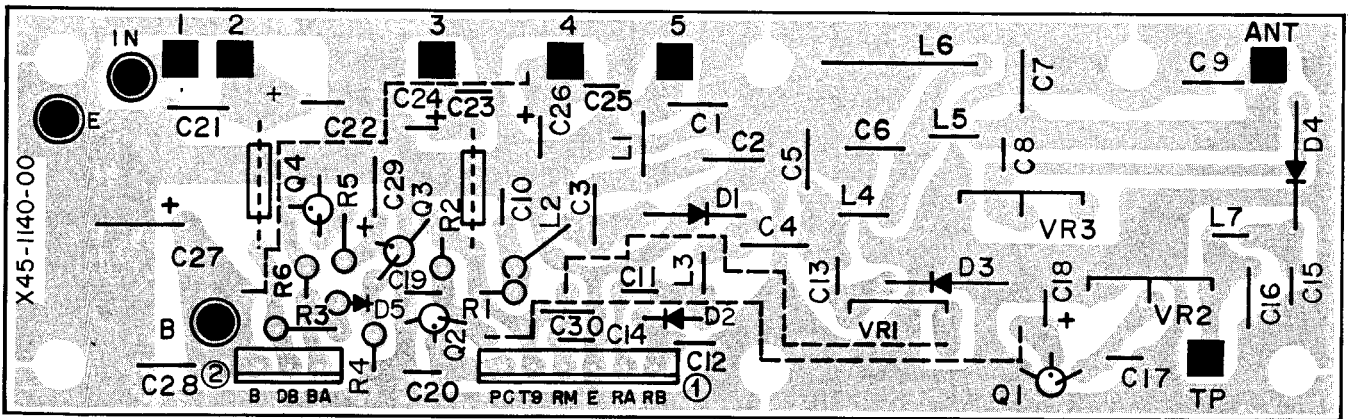

Q1,2: 4: 2SC1815(Y) Q3: 2SA1015(Y) Q5: M57713 D1: MI402 D2: 1S2588 D3: 4: 1N60 D5: 1S1555 D6: U05B

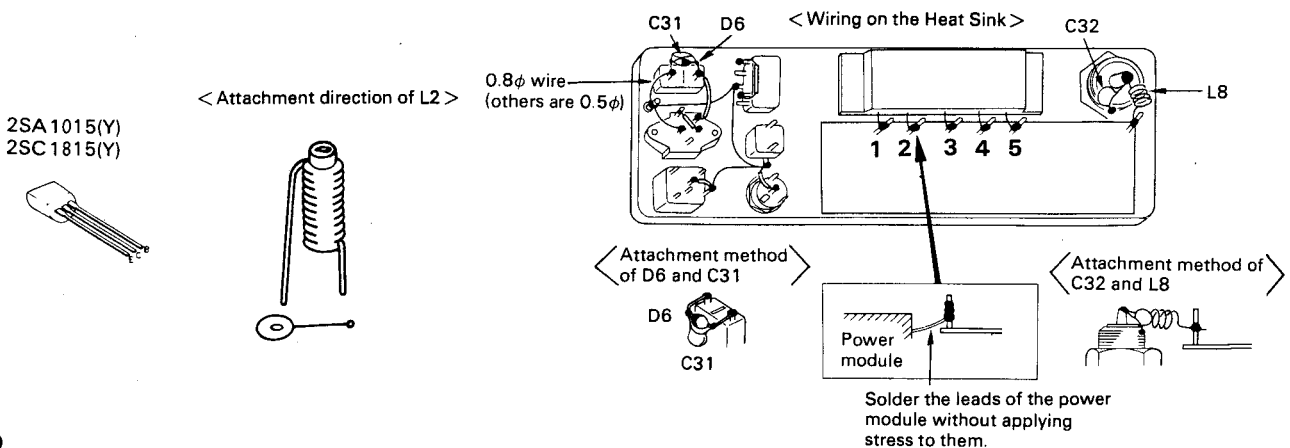

PC BOARD VIEWS

▼ MODE (J25-2714-04)

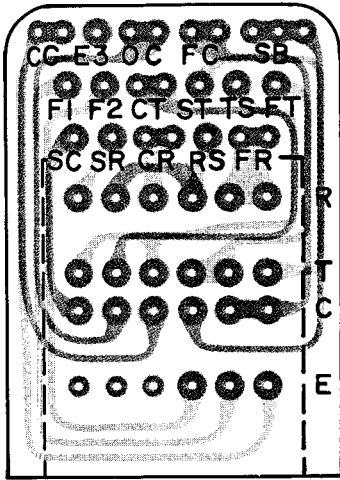

▼ TX OFF SET (J25-2744-04)

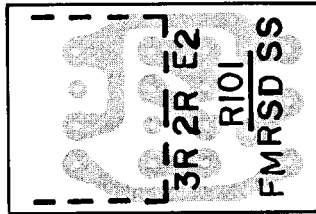

▼ MEMORY (J25-2715-04)

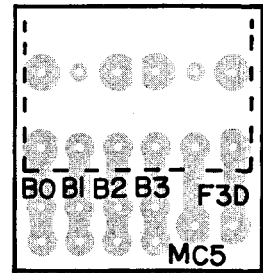

▼ SCAN (J25-2716-24)

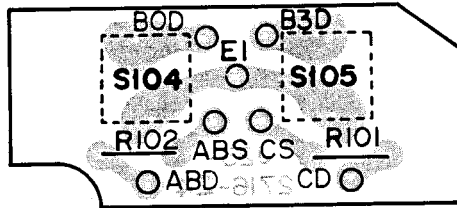

▼ SIDE TONE UNIT (X52-1140-10)
PARTS LIST: Page 21

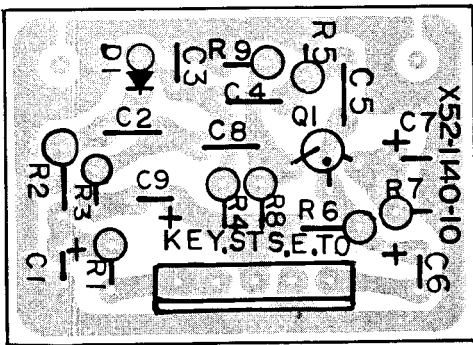

Q1: 2SC1775(E) D1: 1S1555

NOTES:

All printed circuit views are component side.

[Transistor Terminal Indication]

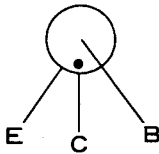

2SC460(B)

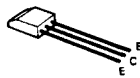

▼ CAR UNIT (X50-1630-11)
PARTS LIST: Page 21

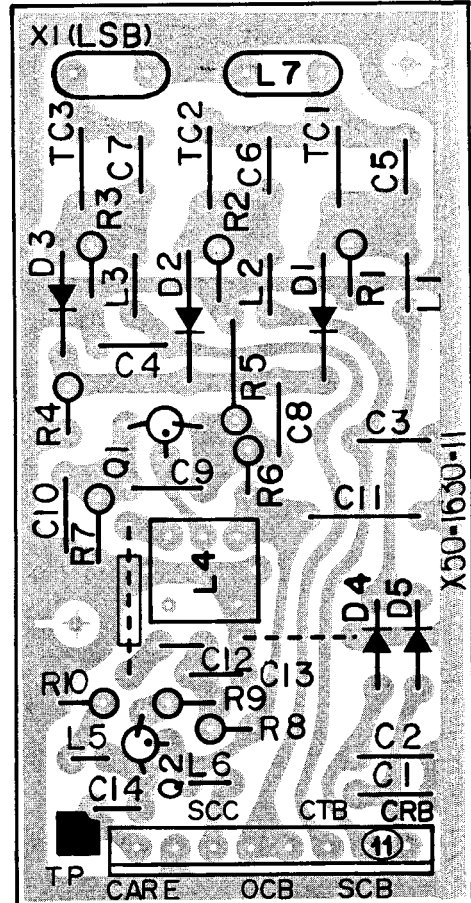

Q1,2:2SC460(B) D1~5:1S1555

PC BOARD VIEW

▲ PLL UNIT (X50-1620-00)(W)(T) (X50-1620-11)(K)(X)

- Fix this portion in place with silicone.
- Be careful not put any silicone into the core of the coil.

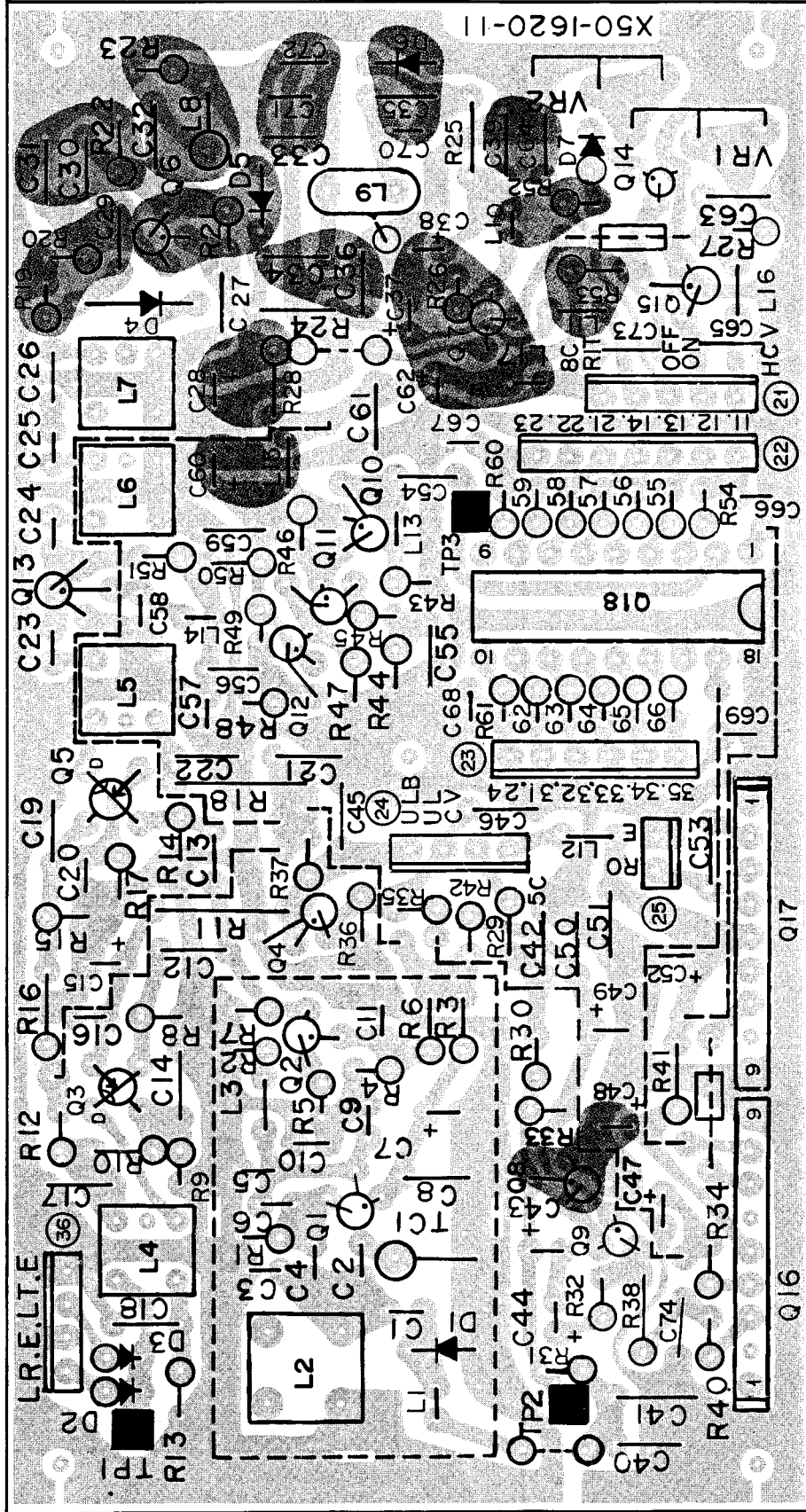

Q1:2SK19(GR) Q2:13:2SC1923(O) Q3:5:3SK74(L) Q4:2SC1775(E) Q6:10-12:2SC460(B) Q7:2SK30A(GR) Q8:9:2SC2240(GR)
 Q14:15:2SC1815(Y) Q16:TC5081P Q17:TC5082P-GL Q18:TC9122P
 D1:5:1SV50S D2:3:1S2588 D4:1S516 D6:1S2208 D7:1S1555

< Attachment direction of TC1 and L2 >

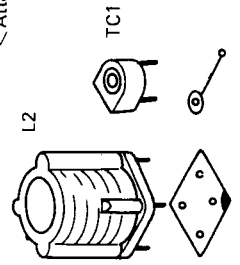

< Attachment method of L9 >

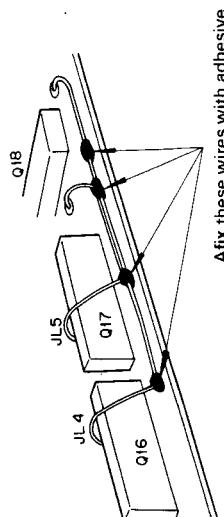
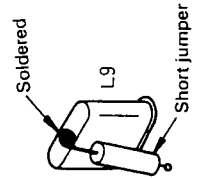

Atix these wires with adhesive

CIRCUIT DIAGRAM

▼ PLL Unit (X50-1620-00)(W)(T) (X50-1620-11)(K)(X) PARTS LIST: Page 20

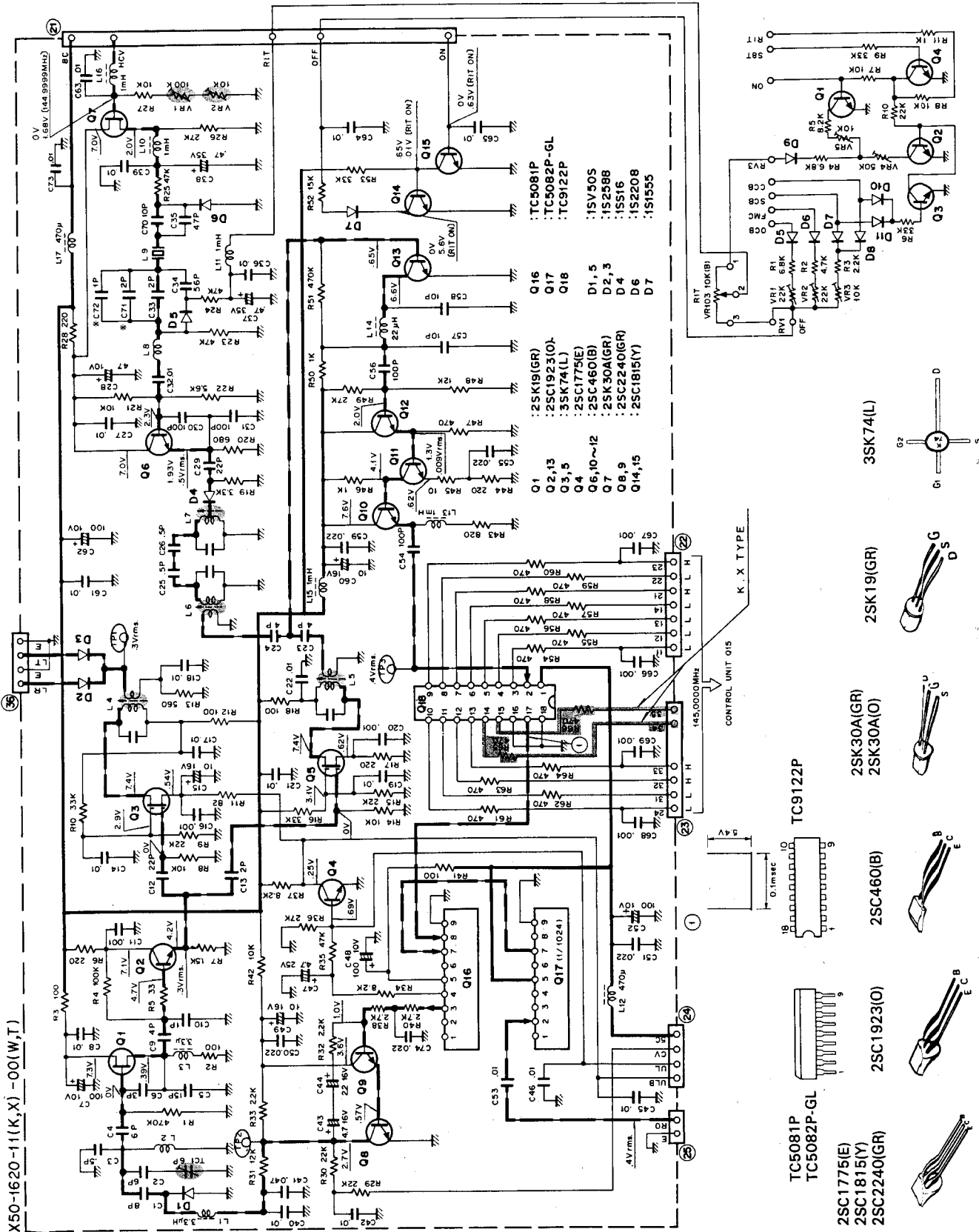

PC BOARD VIEW

▼ CONTROL UNIT (X53-1160-11) (K) (X53-1160-61 (W)(T) (X53-1160-71) (X)

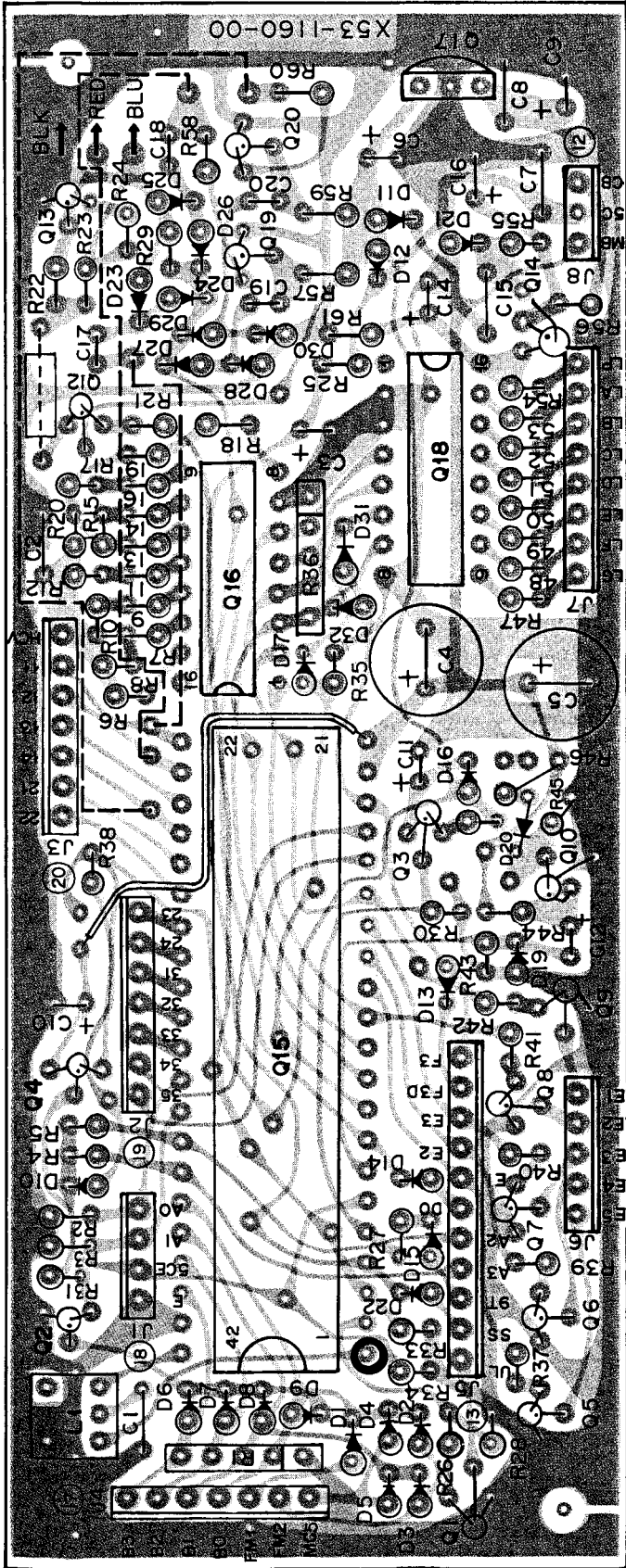

Q1:2.5~13.19.20:2SC1815(Y) Q3:4:2SA1015(Y) Q14:2SC496(Y) Q15:μPD650C-021 Q16:MN1201A
 Q17:NJM78L06K Q18:TC5022BP D1:13.14.17.22~32:1N60 D2~12.15.16.19:1S1555
 D20:MA522(Q) D21:XZ-057

< Attachment method of the shield case and Tone transducer >

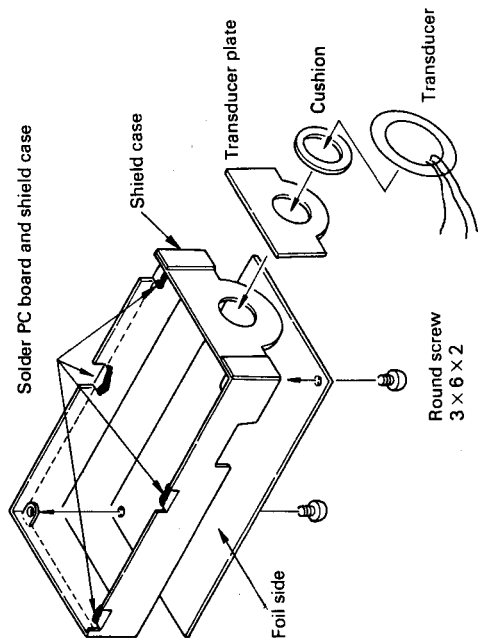

< Attachment direction of D20 >

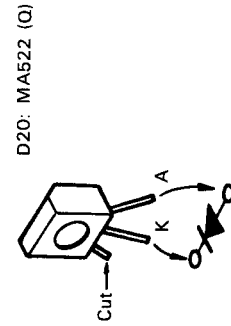

< Attachment direction of R1 and R36 >

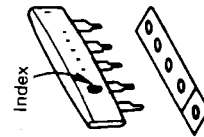

CIRCUIT DIAGRAM

▼ CONTROL UNIT (X53-1160-11) (K) (X53-1160-61) (W)(T) (X53-1160-71)(X)

PARTS LIST: Page 22

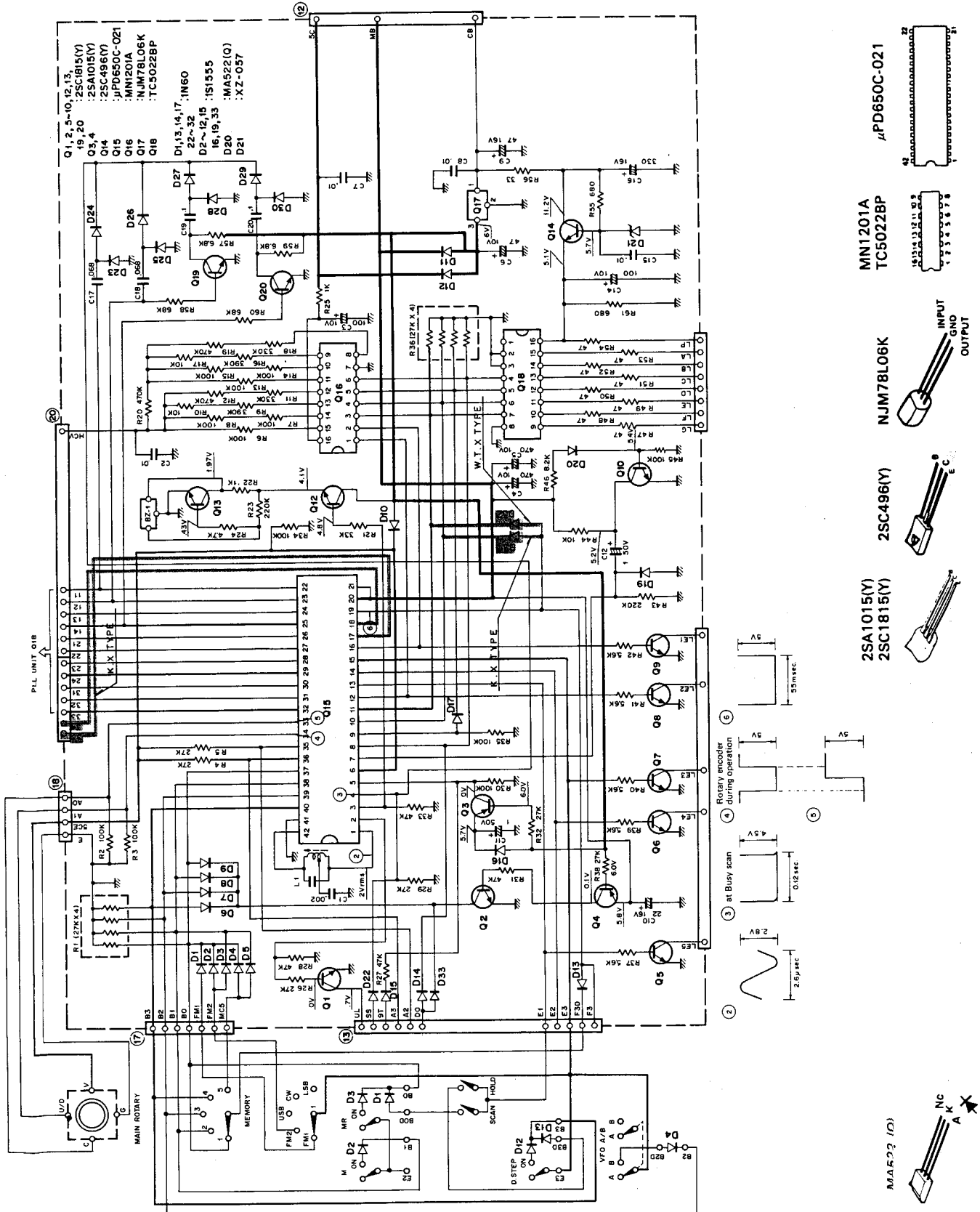

PC BOARD VIEW

▼ RX UNIT (X55-1260-11)(K)(X) (X55-1260-61)(W)(T) PARTS LIST: Page 22

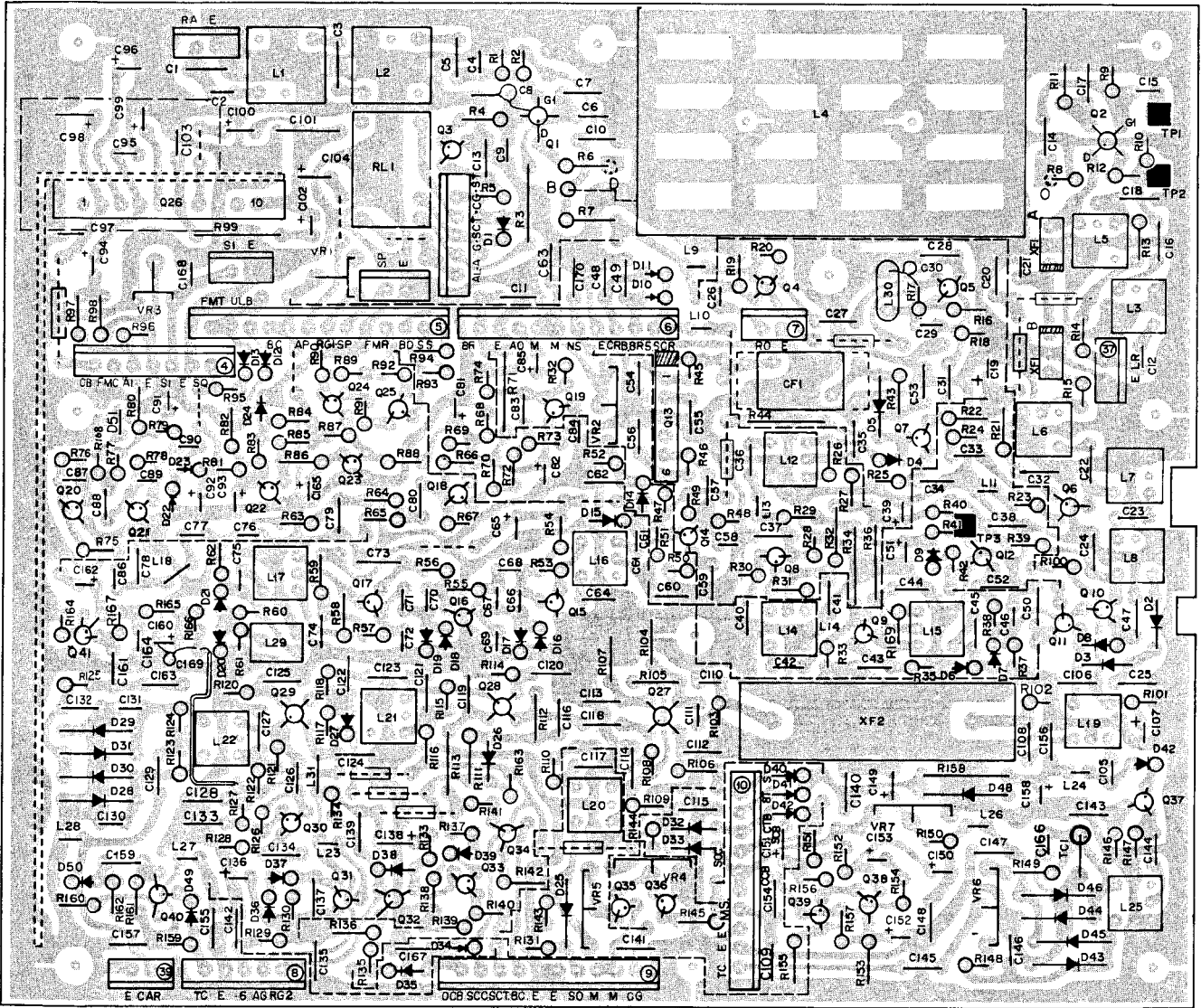

Q1:3SK74(L)(K) 3SK76(W) Q2:3SK74(L) Q3,10~12,18,19,22~24,31,36,38,39:2SC1815(Y) Q4,5,8,9,14~17,30,40:2SC460(B)
 Q6:2SK125 Q7:2SC1923(O) Q13:TA7302P Q20,21:2SC1775(E) Q25,33,35:2SA1015(Y) Q26:HA1366W Q27~29:3SK74(M)
 Q32:2SK30A(GR) Q34:2SK30A(O) Q37:2SK61(GR) Q41:2SC2240(GR)
 D1,4,5,10~13,16~19,26,27,32~35,38~41,47~50:1S1555 D2,3,42:1S1587
 D6~8,14,15,20~23,28~31,36,37,43~46:1N60 D9:WZ-032 D24:1S1212 D25:1S2588 D51:D33A

2SA1015(Y)
 2SC1815(Y)
 2SC1775(E)
 2SC2240(GR)

2SC460(B)

2SC1923(O)

3SK74(L)
 3SK74(M)

3SK76

HA1366W

TA7302P

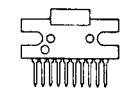
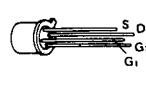
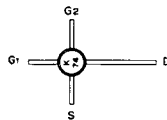
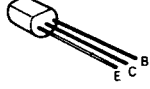
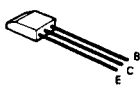
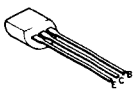

2SK125

2SK61(GR)

2SK30A(GR)
 2SK30A(O)

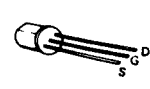
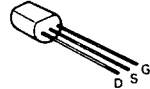
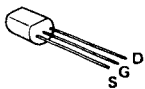

PC BOARD VIEW

▼ TXUNIT (X56-1370-10) (K)(X) (X56-1370-51) (T)
(X56-1370-61) (W)

PARTS LIST: Page 24

Q1:2SC2240 Q2:TA7061AP Q3:4.2SC460(B) Q5:6.2SK61(GR) Q7:3SK74(L) Q8:2SC2538-22-A
Q9,14,17,18,20:2SC2603(E) Q10,11,13,19:2SA1015(Y) Q12:2SA671(B) Q15:2SC496(Y) Q16:FS7808C Q21,22:2SC1815(Y)
Q23,24:2SC458(B) XZ-070
D1,4:1S2208 D2,3:1S2588 D5~7:1TT410 D8,11,15,16,19,20,22,23:1S1555 D9,10:1N60 D12:VD1223
D13,WZ-061 D14:XZ-090 D17,21:XZ-060 D18:XZ-070

32

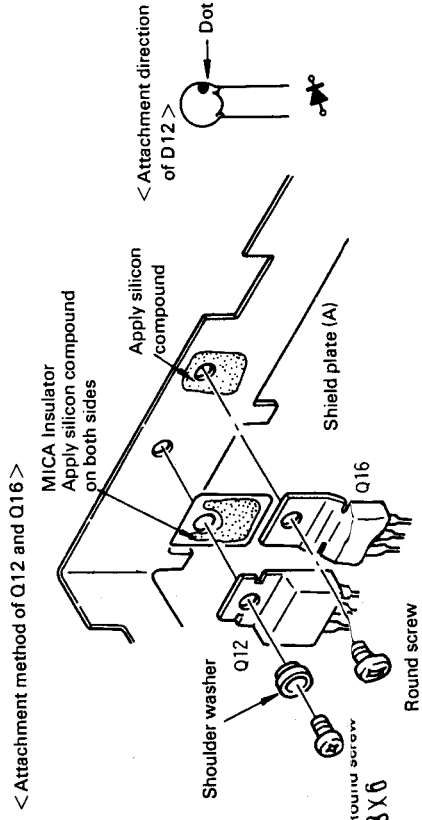
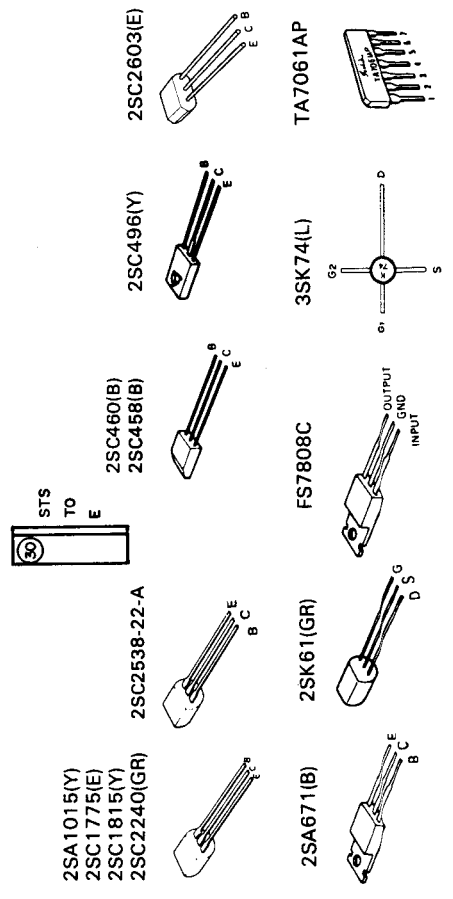
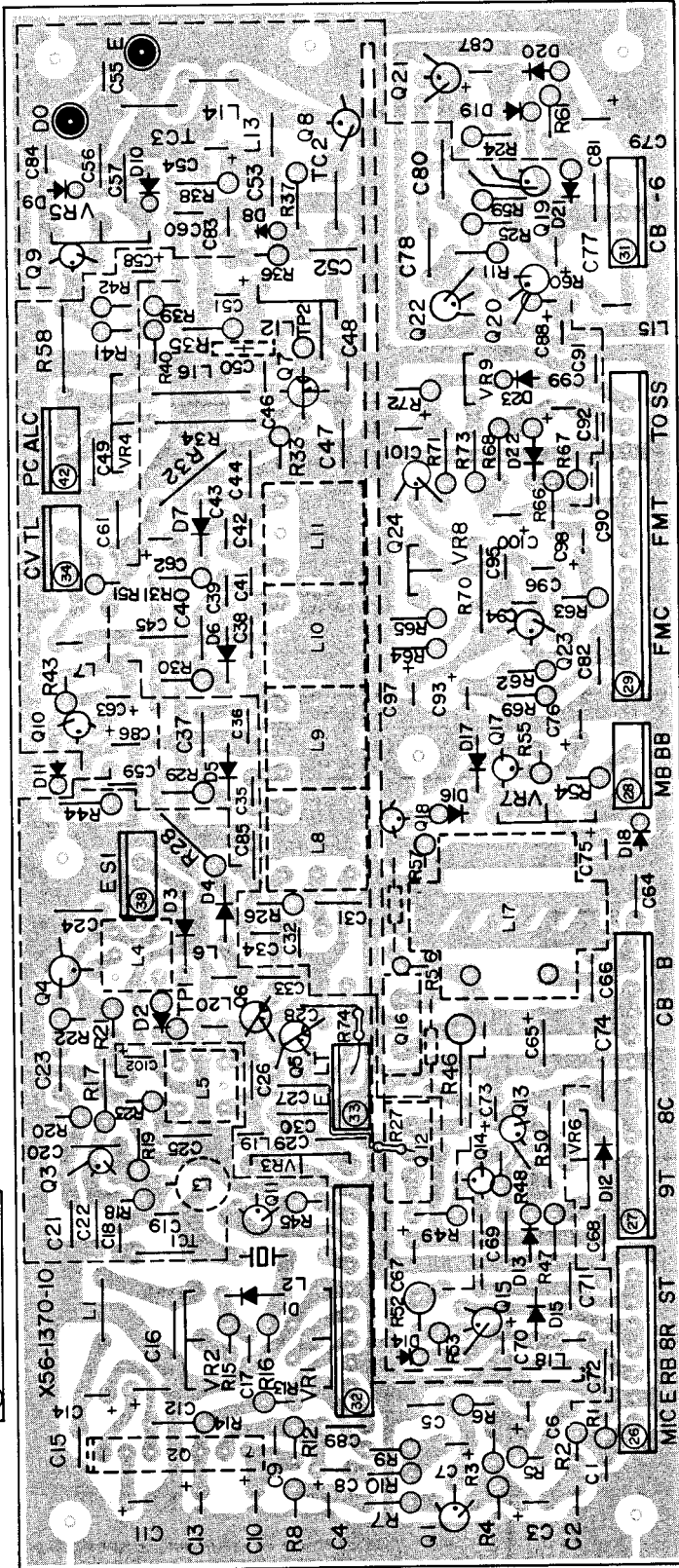

PARTS LIST

Note 1:

K: U.S.A. T: Britain W: Europe X: Australia

Note 2:

Only special type of resistors (example: cement, metal film, etc.) and capacitors (example: electrolytic, tantalum, mylar, temp. coeff. capacitors) are detailed in the PARTS LIST. For the value of all common type components, refer to the schematic diagram of the P.C. board illustration. Resistors not otherwise detailed are carbon type (1/4W or 1/8W). Order carbon resistors and capacitors according to the following example:

A carbon resistor's part number is RD14BY 2E222J.

A ceramic capacitor's number is CK45F1H103Z, CC45TH1H220J.

RESISTOR

1. Type of the carbon resistor

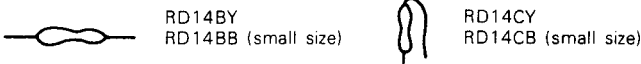

2. Wattage

1W → 3A 3W → 3F 5W → 3H
2W → 3D 4W → 3G

3' = CC45 ○ ○ ...

Ceramic capacitor (type I) temperature coeff. capacitor 1' 3'.

1st word (Color)	C (Black)	L (Red)	P (Orange)	R (Yellow)	S (Green)	T (Blue)	U (Violet)
ppm/°C	0	-80	-150	-220	-330	-470	-750

3 = CK45 ○

Ceramic capacitor (type II) 3

Cord	B	D	E	F
Operating temperature °C	-30 +85	-30 +85	-30 +85	-10 +70

6 = Tolerance

Cord	C	D	G	J	K	M	X	Z	P	No cord
(%)	±0.25	±0.5	±2	±5	±10	±20	+40 -20	+80 -20	+100 -0	More than 10 μF -10 ~ +50 Less than 4.7 μF -10 ~ +75

Less than 10 pF

Cord	B	C	D	F	G
(pF)	±0.1	±0.25	±0.5	±1	±2

Abbreviation		Abbreviation	
Cap.	Capacitor	ML	Mylar
C	Ceramic	S	Styren
E	Electrolytic	T	Tantalum
MC	Mica		

3. Resistance value

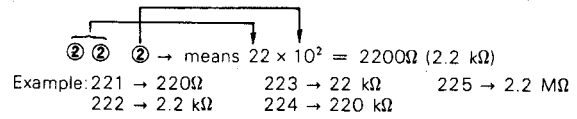

4. Tolerance

J = ±5% (Gold) K = ±10% (Silver)

CAPACITORS

Type I

Type II

CC	45	TH	1H	220	J	CK	45	F	1H	103	Z
1'	2	3'	4	5	6	1	2	3	4	5	6
1 = Type	ceramic, electrolytic, etc.	4 = Voltage rating									
2 = Shape	round, square, etc.	5 = Value									
3 = Temp range		6 = Tolerance									
3' = Temp coefficient											

Ex. CC45TH = -470 ±60 ppm/°C

2nd Word	G	H	J	K	L
ppm/°C	±30	±60	±120	±250	±500

CC45 ...

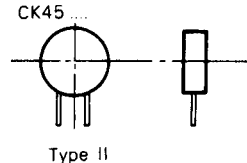
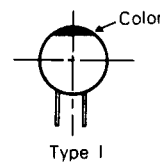

Type I

Type II

5 = Capacitor value

Example: 010 → 1. pF
100 → 10 pF
101 → 100 pF
102 → 1000 pF = 0.001μF
103 → 0.01 μF

GENERAL

☆: New Parts

Ⓐ: from S/N 008 × × × × ~ 012 × × × ×
Ⓑ: from S/N 101 × × × × ~

Ref. No.	Parts No.	Description	Re- marks
—	A01-0762-13	Case (upper)	☆
—	A01-0763-12	Case (lower)	☆
—	A13-0612-02	Angle ass'y (right)	☆
—	A13-0613-02	Angle ass'y (left)	☆
—	A13-0614-04	Angle (Top)	☆
—	A20-2372-15	Panel	☆
—	B01-0626-02	Panel escutcheon (K),(X)	☆
—	B01-0627-02	Panel escutcheon (W)	☆
—	B01-0628-02	Panel escutcheon (T)	☆
—	B03-0513-14	Switch mask (B) × 6	☆
—	B05-0701-04	SP grill cloth	☆
—	B05-0712-14	Grill cloth 148 × 27 mm	☆

Ref. No.	Parts No.	Description	Re- marks
—	B05-0713-04	Grill cloth 32 × 32 mm	☆
—	B07-0621-03	Side escutcheon × 2	☆
—	B10-0625-04	Front glass	☆
—	B31-0625-05	S meter	☆
—	B40-2490-04	Model name plate (T)	☆
—	B40-2509-04	Model name plate (K)	☆
—	B40-2510-04	Model name plate (W)(X)	☆
—	B46-0058-00	Warranty card (K)	☆
—	B50-2718-00	Operating manual (K)	☆
—	B50-2719-00	Operating manual (W)	☆
—	B50-2720-00	Operating manual (T)	☆
—	E06-0651-05	6P Metal socket (MIC jack)	☆

PARTS LIST

Ref. No.	Parts No.	Description	Re- marks
—	E07-0651-05	6P Metal consent (MIC plug)	☆
—	E09-0471-05	4P Plug TONE PAD (K)	
—	E12-0001-05	Phone plug	
—	E12-0401-05	STBY plug	☆
—	E23-0015-04	Lug terminal	
—	E29-0412-05	1P Connector (male)	☆
—	E29-0413-05	1P Connector (female)	☆
—	E30-1648-05	DC cord ass'y 4A	
—	F05-4022-05	Fuse (4A) × 2	
—	F15-0622-04	Shadow mask (meter)	
—	F15-0627-04	Shadow mask (LED)	☆
—	F20-0078-05	MICA insulator (Q101)	
—	F29-0014-05	Shoulder washer (Q101)	
—	G02-0505-05	Knob spring RIT	
—	G09-0412-04	Eeath spring	☆
—	G10-0609-04	Cushion (upper case)	☆
—	G53-0510-04	Packing × 4 upper, lower case	☆
—	H01-2676-03	Carton (inside)(K)(W)(X)	☆
—	H01-2677-03	Carton (inside)(T)	☆
—	H10-2501-03	Styrene foam cushion	
—	H10-2528-12	Packing fixture	☆
—	H25-0049-03	Protective bag	
—	H25-0079-04	Protective bag (MIC)	
—	H25-0103-04	Protective bag (cord)	
—	H25-0106-04	Protective bag	
—	J02-0069-05	Foot × 2	
—	J02-0416-04	Metal foot	☆
—	J25-2714-04	PC board MODE	☆
—	J25-2715-04	PC board Memory	☆
—	J25-2716-24	PC board SCAN	☆
—	J25-2744-04	PC board TX OFF SET	☆
—	J30-0509-04	Spacer	☆
—	J31-0514-04	Spacer collar × 2	☆
—	J32-0739-14	Round boss × 5 PLL	☆ (A)
—	J32-0739-24	Round boss × 5 PLL	☆ (B)
—	J42-0409-04	Knob bush	
—	J61-0019-05	Vinyletie × 5	
—	K21-0749-03	Main knob	☆
—	K21-0750-04	Knob (C) RF GAIN	☆
—	K23-0727-04	Knob (A) × 2 MODE. MEMORY	☆
—	K23-0728-04	Knob (B) × 2 VOL. SQL	☆
—	K23-0729-04	Knob (D) RIT	☆
—	K23-0733-04	Knob (E) TX OFF SET	☆
—	K27-0408-04	Push knob (A) × 5 M,MR,NB,RIT,D.STEP	☆
—	K27-0409-04	Push knob (B) × 2 SCAN.HOLD	☆
—	K27-0412-04	Push knob (D) VFO A/B	☆
—	K29-0733-04	Push knob (C)	☆
—	K23-0733-04	Knob (E) TX OFF SET	☆
—	N09-0008-04	Screw × 4 (angle)	
—	N14-0510-04	Flange nut × 4	
—	N14-0512-05	Speed nut × 4	☆
—	N15-1040-46	Flat washer × 4 (angle)	
—	N15-1060-46	Flat washer	
—	N16-0060-46	Spring washer × 4	
—	N33-3006-45	Round flat screw (case)	
—	N35-3006-45	Bind screw × 4 (Speaker mounting plate)	
—	N99-0304-04	Allen head bolt × 4 (angle)	

Ref. No.	Parts No.	Description	Re- marks
R103	RS14AB3A101J	Metal film 100Ω ±5% 1W	
VR101	R01-3409-05	Potentiometer 10 kΩ (A) SW VOL	☆
VR102	R01-4405-05	Potentiometer 50 kΩ (B) SW SQL	☆
VR103,104	R19-3406-05	Potentiometer 10 kΩ (B) × 2 RIT, RF GAIN	☆
S101	W02-0308-05	Rotary encoder	☆
S102	S01-2421-05	Rotary switch MODE	☆
S103	S01-1420-05	Rotary switch M.CH	☆
S104,105	S59-1405-05	Key board switch SCAN, HOLD	☆
S106	S40-2403-05	Push switch A/B (W)	
S107	S40-2403-05	Push switch H/L (K)(T)(X)	
S107	S40-2406-05	Push switch TONE (W)	
S108	S01-1421-05	Rotary switch TX OFF SET	☆
—	S50-1406-05	Tact switch (MIC)	☆
—	T03-0027-15	Speaker	
—	T91-0311-05	Microphone (T)	☆
—	T91-0313-05	Microphone (K)(W)(X)	☆
Q101	V01-0671-16	TR 2SA671 (B)	
Q102	V03-2603-06	TR 2SC2603 (E)	
D101	V11-6172-26	5 digit LED SL-1502	☆
D102	V11-7272-36	LED PR5532K ON AIR	☆
D103	V11-7272-46	LED PY5532K BUSY	☆
D104	V11-6172-56	LED SLP-144B (T)	☆
D105	V11-6172-56	LED SLP-144B	☆
D106	V11-6176-66	LED SLP-244B VFO A/B	☆
—	W01-0401-04	Allen key (angle)	
—	X41-1290-11	Switch unit	☆
—	X45-1140-00	Final unit (W)(T)(X)	☆
—	X45-1140-11	Final unit (K)	☆
—	X50-1620-00	PLL unit (W)(T)	☆
—	X50-1620-11	PLL unit (K)(X)	☆
—	X50-1630-11	CAR unit	☆
—	X52-1140-10	Side tone unit	☆
—	X53-1160-11	Control unit (K)	☆
—	X53-1160-61	Control unit (W)(T)	☆
—	X53-1160-71	Control unit (X)	☆
—	X55-1260-11	RX unit (K)(X)	☆
—	X55-1260-61	RX unit(W)(T)	☆
—	X56-1370-10	TX unit (K)(X)	☆
—	X56-1370-51	TX unit (T)	☆
—	X56-1370-61	TX unit (W)	☆

Ref. No.	Parts No.	Description	Re- marks
C1	CC45SL1H220J	C 22 pF ±5%	
VR1, 2	R12-3415-05	Semi-fixed resistor 22 kΩ	
VR3	R12-3421-05	Semi-fixed resistor 10 kΩ	☆
VR4	R12-4020-05	Semi-fixed resistor 50 kΩ (2 pΩ)	
VR5	R12-3421-05	Semi-fixed resistor 10 kΩ	☆
Q1~4	V03-1815-06	TR 2SC1815(Y)	

SWITCH UNIT (X41-1290-11)

Ref. No.	Parts No.	Description	Re- marks
C1	CC45SL1H220J	C 22 pF ±5%	
VR1, 2	R12-3415-05	Semi-fixed resistor 22 kΩ	
VR3	R12-3421-05	Semi-fixed resistor 10 kΩ	☆
VR4	R12-4020-05	Semi-fixed resistor 50 kΩ (2 pΩ)	
VR5	R12-3421-05	Semi-fixed resistor 10 kΩ	☆
Q1~4	V03-1815-06	TR 2SC1815(Y)	

PARTS LIST

Ref. No.	Parts No.	Description	Re- marks
D1~4, 12~15	V11-0051-05	Diode 1N60	
D5~11	V11-0076-05	Diode 1S1555	
S1	S40-2409-15	Push switch M	
S2	S40-2405-05	Push switch MR	
S3,4	S40-2404-05	Push switch RIT, NB	
S5	S40-2405-05	Push switch D. STEP	
—	E23-0046-04	Square terminal	

Ref. No.	Parts No.	Description	Re- marks
—	E08-0471-05	4P Socket TONE PAD (K)	
—	E11-0405-05	Key jack	☆
—	E11-0406-05	STBY Jack	☆
—	E11-0409-05	Earphone jack	☆
—	E40-0373-05	Mini connect wafer 3P	
—	E40-0673-05	Mini connect wafer 6P	
—	F01-0744-15	Heat sink (W)(T)(X)	
—	F01-0746-05	Heat sink (K)	☆

FINAL UNIT (X45-1140-00)(W)(T)(X) (X45-1140-11)(K)

PLL UNIT (X50-1620-00)(W)(T) (X50-1620-11)(K)(X)

Schematic: Page 13

Ref. No.	Parts No.	Description	Re- marks
C1,2	CC45SL2H070D	C 7pF ±0.5pF	
C3,4	CC45SL2H101J	C 100pF ±5%	
C5	CC45SL2H330J	C 33pF ±5%	
C6	CC45SL2H390J	C 39pF ±5%	
C7	CC45SL2H100D	C 10pF ±5%	
C8	CC45CH1H010C	C 1pF ±0.25pF	
C9	CC45SL2H220J	C 22pF ±5%	
C11	CC45CH1H330J	C 33pF ±5%	
C13	CC45CH1H0R5C	C 0.5pF ±0.25pF	
C18	CS15E1C010M	T 1μF 16V	
C22	CE04W1C101Q	E 100μF 16V	
C24	CE04W1C470Q	E 47μF 16V	
C26	CE04W1C101Q	E 100μF 16V	
C27	C90-0817-05	E 1000μF 16V <small>(small)</small>	
C32	CC45SL2H120J	C 12pF ±5%	
C29	CS15E1V0R1M	T 0.1μF 35V	
VR1	R12-5024-05	Semi fixed resistor 100 kΩ (2 pole)	
VR2	R12-4016-05	Semi-fixed resistor 50 kΩ	
VR3	R12-0048-05	Semi-fixed resistor 100Ω	
Q1,2	V01-1815-06	TR 2SC1815(Y)	
Q3	V01-1015-06	TR 2SA1015(Y)	
Q4	V01-1815-06	TR 2SC1815(Y)	
Q5	V30-1131-06	Power module M57713	☆
D1	V11-5260-16	Diode MI402	
D2	V11-0414-05	Diode 1S2588	
D3,4	V11-0051-05	Diode 1N60	
D5	V11-0076-05	Diode 1S1555	
D6	V11-0270-05	Diode U05B	
L1	L34-0823-05	VHF Coil 5φ3T	
L2	L34-0438-05	Coil 0.9μH	
L3	L34-0692-05	VHF Coil 5φ4T	
L4,5	L34-0817-05	VHF Coil 5φ3T	
L6	L33-0025-05	Choke coil 1μH	
L7	L40-1001-03	Ferri-inductor 10μH	
L8	L34-0887-05	VHF Coil 5φ3T	☆
—	B42-1682-04	T. Pad badge (K)	☆
—	E04-0102-05	UHF Type receptacle	
—	E08-0203-25	2P Connector	
—	E08-0304-05	Power jack BACK UP	

Ref. No.	Parts No.	Description	Re- marks
C1	CC45PG1H080D	C 8pF ±0.5pF	
C2	CC45CH1H060D	C 6pF ±0.5pF	
C3	CC45CH1H0R5C	C 0.5pF ±0.25pF	
C4	CC45CH1H060D	C 6pF ±0.5pF	
C5	CC45CH1H150J	C 15pF ±5%	
C6	CC45CH1H030C	C 3pF ±0.25pF	
C7	CE04W1A101Q	E 100μF 10V	
C9	CC45CH1H040C	C 4pF ±0.25pF	
C10	CC45CH1H010C	C 1pF ±0.25pF	
C12	CC45CH1H220J	C 22pF ±5%	
C13	CC45CH1H020C	C 2pF ±0.25pF	
C15	CE04W1C100Q	E 10μF 16V	
C23,24	CC45CH1H040C	C 4pF ±0.25pF	
C25,26	CC45CH1H0R5C	C 0.5pF ±0.25pF	
C28	CE04W1A470Q	E 47μF 10V	
C29	CC45CH1H220J	C 22pF ±5%	
C30,31	CC45CH1H101J	C 100pF ±5%	
C33	CC45TH1H020C	C 2pF ±0.25pF	
C34	CC45TH1H560J	C 56pF ±5%	
C35	CC45PG1H470J	C 47pF ±5%	
C37,38	CS15E1VR47M	T 0.47μF 35V	
C40	C91-0455-05	C 0.01μF ±10%	
C41	CQ92M1H473K	ML 0.047μF ±10%	
C43	CS15E1C4R7M	T 4.7μF 16V	
C44	CS15E1C2R2M	T 2.2μF 16V	
C47	CE04W1E4R7Q	E 4.7μF 25V	
C48	CE04W1A101Q	E 100μF 10V	
C49	CE04W1H010Q	E 1μF 50V	
C50,51	C91-0457-05	C 0.022μF ±10%	
C52	CE04W1A101Q	E 100μF 10V	
C54	CC45SL1H101J	C 100pF ±5%	
C55	CQ92M1H223K	ML 0.022μF ±10%	
C56	CC45SL1H101J	C 100pF ±5%	
C57,58	CC45CH1H100D	C 10pF ±0.5pF	
C59	C91-0457-05	C 0.022μF ±10%	
C60	CE04W1C100Q	E 10μF 16V	
C62	CE04W1A101Q	E 100μF 10V	
C70	CC45CH1H100D	C 10pF ±0.5pF	
C71	CC45TH1H020C	C 2pF ±0.25pF	
C72	CC45TH1H010C	C 1pF ±0.25pF	
C74	CQ92M1H223K	ML 0.022μF ±10%	
VR1	R12-5014-05	Semi-fixed resistor 100 kΩ	
VR2	R12-3025-05	Semi-fixed resistor 10 kΩ	
TC1	C05-0062-05	Ceramic Trimmer 6pF	

PARTS LIST

Ref. No.	Parts No.	Description	Re- marks
Q1	V09-1001-16	FET 2SK19(GR)TR10-5	
Q2	V03-1923-06	TR 2SC1923(O)	
Q3	V09-1002-56	FET 3SK74(L)	
Q4	V03-1775-06	TR 2SC1775(E)	
Q5	V09-1002-56	FET 3SK74(L)	
Q6	V03-0079-05	TR 2SC460(B)	
Q7	V09-0060-05	FET 2SK30A(GR)	
Q8,9	V03-2240-06	TR 2SC2240(GR)	
Q10~12	V03-0079-05	TR 2SC460(B)	
Q13	V03-1923-06	TR 2SC1923(O)	
Q14,15	V03-1815-06	TR 2SC1815(Y)	
Q16	V30-1132-06	IC TC5081P	☆
Q17	V30-1147-06	IC TC5082P-GL	☆
Q18	V30-1036-16	IC TC9122P	
D1	V11-1260-36	Vari-cap Diode 1SV50S	
D2,3	V11-0414-05	Diode 1S2588	
D4	V11-0374-05	Diode 1S1555	
D5	V11-1260-36	Vari cap Diode 1SV50S	
D6	V11-0317-05	Vari-cap Diode 1S2208	
D7	V11-0076-05	Diode 1S1555	
L1	L40-3391-03	Ferri-inductor 3.3μH	
L2	L32-0624-05	Oscillating coil VCO	☆
L3	L40-3391-03	Ferri-inductor 3.3μH	
L4	L34-0820-05	Tuning coil	
L5	L34-0683-05	Tuning coil	
L6,7	L34-0901-05	Tuning coil	☆
L8	L33-0631-05	Choke coil 4.7μH	☆
L9	L77-0855-05	Crystal 14.2005 MHz	☆
L10,11	L40-1021-03	Ferri-inductor 1mH	
L12	L40-4711-03	Ferri-inductor 470μH	
L13	L40-1021-03	Ferri-inductor 1mH	
L14	L40-1501-03	Ferri-inductor 15μH	
L15,16	L40-1021-03	Ferri-inductor 1mH	
L17	L40-4711-03	Ferri-inductor 470μH	
—	E40-0273-05	Mini connect wafer 2P	
—	E40-0473-05	Mini connect wafer 4P	
—	E40-0573-05	Mini connect wafer 5P	
—	E40-0673-05	Mini connect wafer 6P (K)	
—	E40-0773-05	Mini connect wafer 7P	

Ref. No.	Parts No.	Description	Re- marks
L5,6	L40-1511-03	Ferri-inductor 150μH	
L7	L77-0856-05	Crystal 10.6943 MHz	☆
X1	L77-0857-05	Crystal (LSB) 10.6965 MHz	☆
—	E23-0046-04	Square terminal	

SIDE TONE UNIT (X52-1140-10)

Ref. No.	Parts No.	Description	Re- marks
C1	CS15E1V0R1M	T 0.1μF 35V	
C2	CQ92M1H123K	ML 0.012μF ±10%	
C3	CC45SL1H101J	C 100pF ±5%	
C4,5	CQ92M1H103K	ML 0.01μF ±10%	
C6	CS15E1V0R1M	T 0.1μF 35V	
C7	CS15E1A100M	T 10μF 10V	
C8	CQ92M1H123K	ML 0.012μF ±10%	
C9	CE04W1A470Q	E 47μF 10V	
Q1	V03-1775-06	TR 2SC1775(E)	
D1	V11-0076-05	Diode 1S1555	
—	E40-0574-05	Mini connect wafer 5P	

CAR UNIT (X50-1630-11)

Ref. No.	Parts No.	Description	Re- marks
C5	CC45SL1H330J	C 33pF ±5%	
C6,7	CC45SL1H220J	C 22pF ±5%	
C9,10	CC45SL1H221J	C 220pF ±5%	
C12	CC45CH1H030C	C 3pF ±0.25pF	
C13	CC45SL1H470J	C 47pF ±5%	
TC1~3	C05-0067-05	Ceramic trimmer 25pF	
Q1,2	V03-0079-05	TR 2SC460(B)	
D1~5	V11-0076-05	Diode 1S1555	
L1~3	L40-1021-03	Ferri-inductor 1mH	
L4	L30-0281-05	IFT	

PARTS LIST

**CONTROL UNIT (X53-1160-11)(K)
(X53-1160-61)(T)
(X53-1160-71)(X)**

Schematic: Page 15

**RX UNIT (X55-1260-11)(K)(X)
(X55-1260-61)(W)(T)**

Ref. No.	Parts No.	Description	Re- marks
C1	CQ92M1H223K	ML 0.022μF	
C3	CE04W1A101Q	E 100μF 10V	
C4.5	CE04W1A471Q	E 470μF 10V	
C6	CE04W1A470Q	E 47μF 10V	
C9	CE04W1C470Q	E 47μF 16V	
C10	CE04W1C220Q	E 22μF 16V	
C11,12	CE04W1H010Q	E 1μF 50V	
C14	CE04W1A101Q	E 100μF 10V	
C16	C90-0811-05	E 330μF 16V	
C17,18	C91-0460-05	Laminated cap. 0.068μF	☆
C19,20	C91-0460-05	Laminated cap. 0.1μF	
R1	R90-0526-05	Resistor 27kΩ × 4	☆
R36	R90-0526-05	Resistor 27kΩ × 4	☆
Q1.2	V03-1815-06	TR 2SC1815(Y)	
Q3.4	V01-1015-06	TR 2SA1015(Y)	
Q5~13	V03-1815-06	TR 2SC1815(Y)	
Q14	V03-0336-05	TR 2SC496(Y)	
Q15	V30-1136-06	Micro computer μPD650C-021	☆
Q16	V30-1008-66	IC MN1201A	
Q17	V30-1067-06	IC NJM78L06K	
Q18	V30-1054-06	IC TC5022BP	
Q19,20	V30-1815-06	TR 2SC1815(Y)	
D1	V11-0051-05	Diode 1N60	
D2~12	V11-0076-05	Diode 1S1555	
D13,14	V11-0051-05	Diode 1N60	
D15,16	V11-0076-05	Diode 1S1555	
D17	V11-0051-05	Diode 1N60	
D19	V11-0076-05	Diode 1S1555	
D20	V11-1162-16	Diode MA522(Q)	
D21	V11-4176-76	Zener diode XZ-057	
D22~30	V11-0051-05	Diode 1N60	
D31	V11-0051-05	Diode 1N60 (K)(X)	
D32	V11-0051-05	Diode	
L1	L30-0503-05	IFT	
—	E40-0373-05	Mini connect wafer 3P	
—	E40-0473-05	Mini connect wafer 4P	
—	E40-0573-05	Mini connect wafer 5P	
—	E40-0773-05	Mini connect wafer 7P	
—	E40-0873-05	Mini connect wafer 8P	
—	E40-1173-05	Mini connect wafer 11P	
—	G11-0605-04	Cushion (Transducer)	☆
—	J29-0403-04	Transducer plate	☆
—	T95-0051-05	Transducer	

Ref. No.	Parts No.	Description	Re- marks
C1	CC45CH1H330J	C 33pF ±5%	
C2	CC45RH1H120J	C 12pF ±5%	
C3	CC45CH1H030C	C 3pF ±0.25pF	
C4	CC45RH1H100D	C 10pF ±0.5pF	
C5	CC45CH1H220J	C 22pF ±5%	
C7	C91-0456-05	C 0.047μF ±10%	
C12	CC45CH1H330J	C 33pF ±5%	
C14	CC45CH1H150J	C 15pF ±5%	
C15	CC45CH1H0R5C	C 0.5pF ±0.25pF	
C16	CC45CH1H020C	C 2pF ±0.25pF	
C19	CE04W1A470Q	E 47μF 10V	
C21	CC45CH1H050C	C 5pF ±0.25pF	
C22	CC45CH1H470J	C 47pF ±5%	
C23	CC45CH1H030C	C 3pF ±0.25pF	
C24	C91-0456-05	C 0.047μF ±10%	
C25	CC45CH1H470J	C 470pF ±5%	
C27	CC45CH1H220J	C 22pF ±5%	
C28	CC45SL1H451J	C 450pF ±5%	
C31	CC45CH1H180J	C 18pF ±5%	
C34	CQ92M1H393K	ML 0.039μF ±10%	
C35	CQ92M1H223K	ML 0.022μF ±10%	
C36	CQ92M1H103K	ML 0.01μF ±10%	
C37	CC45SL1H101J	C 100pF ±5%	
C39	CE04W1C100Q	E 10μF 16V	
C40	CQ92M1H393K	ML 0.039μF ±10%	
C41	CQ92M1H223K	ML 0.022μF ±10%	
C43	CQ92M1H393K	ML 0.039μF ±10%	
C44	CQ92M1H223K	ML 0.022μF ±10%	
C45	CQ92M1H222K	ML 0.0022μF ±10%	
C51	CE04W1H010Q	E 1μF 50V	
C53	CQ92M1H393K	ML 0.039μF ±10%	
C54.55	CQ92M1H473K	ML 0.047μF ±10%	
C56	CQ92M1H393K	ML 0.039μF ±10%	
C57	CQ92M1H103K	ML 0.01μF ±10%	
C59.60	CQ92M1H223K	ML 0.022μF ±10%	
C64	CQ92M1H223K	ML 0.022μF ±10%	
C65	CE04W1A101Q	E 100μF 10V	
C68	CC45SL1H470J	C 47pF ±5%	
C69	CQ92M1H222K	ML 0.0022μF ±10%	
C72	CQ92M1H222K	ML 0.0022μF ±10%	
C73	CQ92M1H473K	ML 0.047μF ±10%	
C74	CQ92M1H223K	ML 0.022μF ±10%	
C75	CQ92M1H102K	ML 0.001μF ±10%	
C76	CQ92M1H332K	ML 0.0033μF ±10%	
C77	CQ92M1H222K	ML 0.0022μF ±10%	
C78	CQ92M1H393K	ML 0.039μF ±10%	
C79	CQ92M1H223K	ML 0.022μF ±10%	
C80	CQ92M1H473K	ML 0.047μF ±10%	
C81.82	CE04W1C220Q	E 22μF 16V	
C83	CQ92M1H103K	ML 0.01μF ±10%	
C84	CQ92M1H332K	ML 0.0033μF ±10%	
C85	CS15E1V0R1M	T 0.1μF 35V	
C86	CQ92M1H222K	ML 0.0022μF ±10%	
C87	CC45SL1H220J	C 22pF ±5%	
C88	CQ92M1H103K	ML 0.01μF ±10%	
C89	CC45SL1H390J	C 39pF ±5%	
C90	CQ92M1H222K	ML 0.0022μF ±10%	
C91	CE04W1A470Q	E 47μF 10V	
C92.93	CS15E1A3R3M	T 3.3μF 10V	
C94	CE04W1H010Q	E 1μF 50V	
C95	CQ92M1H332K	ML 0.0033μF ±10%	
C96	CE04W1A101Q	E 100μF 10V	
C98	CE04W1C471Q	E 470μF 16V	
C99.100	CE04W1A470Q	E 47μF 10V	

PARTS LIST

Ref. No.	Parts No.	Description	Re- marks	Ref. No.	Parts No.	Description	Re- marks
C101	CQ92M1H104K	ML 0.1μF ±10%		Q3	V03-1815-06	TR 2SC1815(Y)	
C102	CE04W1H010Q	E 1μF 50V		Q4.5	V03-0079-05	TR 2SC460(B)	
C103	CC45SL1H101J	C 100pF ±5%		Q6	V09-0136-10	FET 2SK125	
C104	CE04W1A101Q	E 100μF 10V		Q7	V03-1923-06	TR 2SC1923(O)	
C105	CC45CH1H050C	C 5pF ±0.25pF		Q8.9	V03-0079-05	TR 2SC460(B)	
C106	C91-0455-05	C 0.01μF ±10%		Q10~12	V03-1815-06	TR 2SC1815(Y)	
C107	CE04W1C100Q	E 10μF 16V		Q13	V30-1134-06	IC TA7302P	☆
C108	C91-0455-05	C 0.01μF ±10%		Q14~17	V03-0079-05	TR 2SC460(B)	
C109	CC45SL1H101J	C 100pF ±5%		Q18,19,22	V03-1815-06	TR 2SC1815(Y)	
C110	CC45CH1H100D	C 10pF ±0.5pF		~24			
C112~114	C91-0457-05	C 0.022μF ±10%		Q20.21	V03-1175-06	TR 2SC1775(E)	
C115,116	C91-0455-05	C 0.01μF ±10%		Q25	V01-1015-06	TR 2SA1015(Y)	
C117,119	C91-0457-05	C 0.022μF ±10%		Q26	V30-1045-06	IC HA1366W	
C118	CC45CH1H470J	C 47pF ±5%		Q27~29	V09-1013-06	FET 2SK74(M)	
C120~122	C91-0457-05	C 0.022μF ±10%		Q30	V03-0079-05	TR 2SC460(B)	
C123	CC45CH1H100D	C 10pF ±0.5pF		Q31	V03-1815-06	TR 2SC1815(Y)	
C124,125	C91-0457-05	C 0.022μF ±10%		Q32	V09-0060-05	FET 2SK30A(GR)	
C126	CC45CH1H100D	C 10pF ±0.5pF		Q33	V01-1015-06	TR 2SA1015(Y)	
C127	C91-0457-05	C 0.022μF ±10%		Q34	V09-0056-05	FET 2SK30A(O)	
C128,129	C91-0455-05	C 0.01μF ±10%		Q35	V01-1015-06	TR 2SA1015(Y)	
C130	CC45CH1H180J	C 18pF ±5%		Q36	V03-1815-06	TR 2SC1815(Y)	
C131	CC45CH1H100D	C 10pF ±0.5pF		Q37	V09-1014-06	FET 2SK61(GR)	☆
C132,133	C91-0455-05	C 0.01μF ±10%		Q38,39	V03-1815-06	TR 2SC1815(Y)	
C134	CC45CH1H470J	C 47pF ±5%		Q40	V03-0079-05	TR 2SC460(B)	
C135	C91-0455-05	C 0.01μF ±10%		Q41	V03-2240-06	TR 2SC2240(GR)	
C136	CE04W1C100Q	E 10μF 16V		D1	V11-0076-05	Diode 1S1555	
C137	CC45SL1H221J	C 220pF ±5%		D2.3	V11-0370-05	Diode 1S1587	
C138	CE04W1H010Q	E 1μF 50V		D4.5	V11-0076-05	Diode 1S1555	
C143	C91-0457-05	C 0.022μF ±10%		D6~8	V11-0051-05	Diode 1N60	
C144	CC45CH1H040C	C 4pF ±0.25pF		D9	V11-4172-26	Zener diode WZ-032	
C145	C91-0455-05	C 0.01μF ±10%		D10~13	V11-0076-05	Diode 1S1555	
C146	CC45CH1H330J	C 33pF ±5%		D14,15	V11-0051-05	Diode 1N60	
C147,148	C91-0455-05	C 0.01μF ±10%		D16~19	V11-0076-05	Diode 1S1555	
C149	CE04W1H010Q	E 1μF 50V		D20~23	V11-0051-05	Diode 1N60	
C150	CE04W1H3R3Q	E 3.3μF 50V		D24	V11-1262-06	Varistor 1S1212	
C151	CE04W1A470Q	E 47μF 10V		D25	V11-0414-05	Diode 1S2588	
C152	CE04W1E4R7Q	E 4.7μF 25V		D26,27	V11-0076-05	Diode 1S1555	
C153	CE04W1H010Q	E 1μF 50V		D28~31	V11-0051-05	Diode 1N60	
C154	CQ92M1H473K	ML 0.047μF ±10%		D32~35	V11-0076-05	Diode 1S1555	
C155	C91-0455-05	C 0.01μF ±10%		D36,37	V11-0051-05	Diode 1N60	
C156,157	C91-0457-05	C 0.022μF ±10%		D38~41	V11-0076-05	Diode 1S1555	
C158	CE04W1E4R7Q	E 4.7μF 25V		D42	V11-0370-05	Diode 1S1587	
C159	CC45SL1H221J	C 220pF ±5%		D43~46	V11-0051-05	Diode 1N60	
C160	CE04W1C100Q	E 10μF 16V		D47~50	V11-0076-05	Diode 1S1555	
C161	CQ92M1H473K	ML 0.047μF ±10%		D51	V11-3161-86	Thermistor D33A	
C162	CE04W1H010Q	E 1μF 50V		L1.2	L31-0267-05	Tuning coil	
C163	C91-0455-05	C 0.01μF ±10%		L3	L34-0683-05	Tuning coil	
C164	CQ92M1H682K	ML 0.0068μF ±10%		L4	L79-0457-05	Helical block (W) (T)	☆
C165	CS15E1C4R7M	T 4.7μF 16V			L79-0460-05	Helical block (K) (X)	☆
C166	CC45CH1H120J	C 12pF ±5%		L5~8	L30-0281-05	IFT	
TC1	C05-0031-05	Ceramic trimmer 10pF		L9	L40-1511-03	Ferri-inductor 150μH	
VR1	R12-3415-05	Semi-fixed resistor 22 kΩ		L10	L40-4711-03	Ferri-inductor 470μH	
VR2	R12-4016-05	Semi-fixed resistor 50 kΩ		L11	L40-4701-03	Ferri-inductor 47μH	
VR3	R12-3416-05	Semi-fixed resistor 47 kΩ		L12	L30-0503-05	IFT	
VR4	R12-1016-05	Semi-fixed resistor 3 kΩ		L13	L40-1011-03	Ferri-inductor 100μH	
VR5	R12-7013-05	Semi-fixed resistor 500 kΩ		L14	L30-0503-05	IFT	
VR6	R12-0048-05	Semi-fixed resistor 100Ω		L15,16	L30-0504-05	IFT	
VR7	R12-4016-05	Semi-fixed resistor 50 kΩ		L17	L30-0503-05	IFT	
				L18	L40-6825-04	Ferri-inductor 6.8mH	
Q1	V09-1002-56	FET 3SK74(L) (K)(X)		L19	L30-0507-05	IFT	☆
	V09-1012-06	FET 3SK76 (W)(T)		L20~22	L30-0005-05	IFT	
Q2	V09-1002-56	FET 3SK74(L)		L23	L40-1021-03	Ferri-inductor 1mH	

PARTS LIST

Ref. No.	Parts No.	Description	Re- marks
L24	L40-1511-03	Ferri-inductor 150 μ H	
L25	L30-0005-05	IFT	
L26	L40-1021-03	Ferri-inductor 1mH	
L27	L40-4711-03	Ferri-inductor 470 μ H	
L28	L40-1511-03	Ferri-inductor 150 μ H	
L29	L79-0446-05	Ceramic discrici CFY455S	
L30	L77-0858-05	Crystal 10.24 MHz	☆
L31	L40-1021-03	Ferri-inductor 1mH	
CF1	L72-0315-05	Ceramic filter CFW455F	
XF1(A.B)	L71-0216-05	MCF 10.695 MHz	☆
XF2	L71-0215-05	Crystal filter 10.695 MHz SSB	☆
RL1	S51-1407-05	Relay G2E9V	☆
—	E40-0273-05	Mini connect wafer 2P	
—	E40-0573-05	Mini connect wafer 5P	
—	E40-0773-05	Mini connect wafer 7P	
—	E40-1073-05	Mini connect wafer 10P	
—	E40-1273-05	Mini connect wafer 12P	
—	J31-0502-04	PC Board collar	
—	J42-0404-05	PC Board bush	

Ref. No.	Parts No.	Description	Re- marks
C41	CC45CH1H0R5C	C 0.5pF \pm 0.25pF	
C42.43	CC45TH1H050C	C 5pF \pm 0.25pF	
C44	CC45CH1H220J	C 22pF \pm 5%	
C50	C90-0804-05	C 0.001 μ F	
C51	CE04W1E4R7Q	E 4.7 μ F 25V	
C54	CE04W1E4R7Q	E 4.7 μ F 25V	
C55	CC45CH1H100D	C 10pF \pm 0.5pF	
C56	CC45CH1H010C	C 1pF \pm 0.25pF	
C58	CE04W1HR47Q	E 0.47 μ F 50V	
C62.63	CE04W1C100Q	E 10 μ F 16V	
C65	C90-0820-05	E 470 μ F 16V(small)	
C67	CE04W1C100Q	E 10 μ F 16V	
C70	CE04W1C220Q	E 22 μ F 16V	
C73	CE04W1A470Q	E 47 μ F 10V	
C75	CE04W1A470Q	E 47 μ F 10V	
C76	CE04W1C470Q	E 47 μ F 16V	
C77	CE04W1C101Q	E 100 μ F 16V	
C78	CQ92M1H223K	ML 0.022 μ F \pm 10%	
C79	CE04W1C101Q	E 100 μ F 16V	
C80	CQ92M1H473K	ML 0.047 μ F \pm 10%	
C86	CS15E1A3R3M	T 3.3 μ F 10V	
C87	CE04W1C470Q	E 47 μ F 16V	
C88	CE04W1C330Q	E 33 μ F 16V	
C89	CQ92M1H472K	ML 0.0047 μ F \pm 10%	
C91.92		not used (K)	
C93	CE04W1C220Q	E 22 μ F 16V	
C94~96	C91-0433-05	Laminated cap. 0.0039 μ F \pm 5% 50V	
C94~96		not used (K)	
C97	CE04W1C220Q	E 22 μ F 16V	
C98.99	CE04W1H010Q	E 1 μ F 50V	
C100.101	CS15E1A150M	T 15 μ F 10V	
C102	CE04W1C220Q	E 22 μ F 16V	
C93.97~99		Not used (K)	
C100.101		Not used (K)(W)	
R46	RC05GF2H2R2J	Solid 2 Ω 5%.1/2W	
R52	RC05GF2H100J	Solid 10 Ω \pm 5%.1/2W	
R62	R92-0616-05	Metal film 10k Ω \pm 1%.1/4W	
R62		Not used (K)	
R63	RN14BK2E4703F	Metal film 470k Ω \pm 1%.1/4W	
R63		Not used (K)	
R64	R92-0616-05	Metal film 10k Ω \pm 1%.1/4W	
R64		Not used (K)	
R65	R92-0617-05	Metal film 7.5k Ω \pm 1%.1/4W	
R65		Not used (K)	
TC1	C05-0062-05	Ceramic trimmer 6pF	
TC2.3	C05-0030-15	Ceramic trimmer 20pF	
VR1	R12-4016-05	Semi-fixed resistor 50k Ω	
VR2	R12-2015-05	Semi-fixed resistor 5k Ω	
VR3	R12-0042-05	Semi-fixed resistor 500 Ω	
VR4	R12-1016-05	Semi-fixed resistor 3k Ω	
VR5	R12-4016-05	Semi-fixed resistor 50k Ω	
VR6.7	R12-1050-05	Semi-fixed resistor 1k Ω	
VR8	R12-2405-05	Semi-fixed resistor 5k Ω	
VR9	R12-4403-05	Semi-fixed resistor 50k Ω	
Q1	V03-2240-06	TR 2SC2240 (GR)	
Q2	V30-0039-05	IC TA7061AP	
Q3.4	V03-0079-05	TR 2SC460(B)	
Q5.6	V09-1014-06	FET 2SK61 (GR)	
Q7	V09-1002-56	FET 3SK74(L)	
Q8	V03-2538-16	TR 2SC2538-22-A	
Q9	V03-2603-06	TR 2SC2603(E)	

**TX UNIT (X56-1370-10)(K)(X)
(X56-1370-51)(T)
(X56-1370-61)(W)**

Ref. No.	Parts No.	Description	Re- marks
C1.2	CC45SL1H101J	C 100pF \pm 5%	
C3	CS15E1C010M	T 1 μ F 16V	
C4	CE04W1E4R7Q	E 4.7 μ F 25V	
C5	CQ92M1H682K	ML 0.0068 μ F \pm 10%	
C6	CE04W1A470Q	E 47 μ F 10V	
C7	CE04W1H010Q	E 1 μ F 50V	
C8	CQ92M1H472K	ML 0.0047 μ F \pm 10%	
C10	CE04W1A470Q	E 47 μ F 10V	
C11	CE04W1E4R7Q	E 4.7 μ F 25V	
C12	CE04W1A470Q	E 47 μ F 10V	
C13	CE04W1C220Q	E 22 μ F 16V	
C14	CE04W1H010Q	E 1 μ F 50V	
C15	CQ92M1H103K	ML 0.01 μ F \pm 10%	
C16	CQ92M1H393K	ML 0.039 μ F \pm 10%	
C18	CC45TH1H100D	C 10pF \pm 0.5pF	
C19	CC45UJ1H020C	C 2pF \pm 0.25pF	
C20.21	CC45SL1H221J	C 220pF \pm 5%	
C23	CC45CH1H100D	C 10pF \pm 0.5pF	
C26	CC45CH1H330J	C 33pF \pm 5%	
C27.28	CC45CH1H220J	C 22pF \pm 5%	
C32	CC45TH1H020C	C 2pF \pm 0.25pF	
C33.34	CC45TH1H080D	C 8pF \pm 0.5pF	
C35	CC45CH1H070D	C 7pF 0.5pF(W)(T)	
C35	CC45CH1H080D	C 8pF 0.5pF(K)	
C36	CC45TH1H030C	C 3pF \pm 0.25pF(K)	
C36	CC45TH1H040C	C 4pF \pm 0.25pF(W)(T)	
C37	CC45TH1H060D	C 6pF \pm 0.5pF(K)	
C37	CC45TH1H050C	C 5pF \pm 0.25pF(W)(T)	
C38	CC45CH1H0R5C	C 0.5pF \pm 0.25pF	
C39	CC45TH1H040C	C 4pF \pm 0.25pF(K)	
C39	CC45TH1H050C	C 5pF \pm 0.25pF(W)(T)	
C40	CC45TH1H050C	C 5pF \pm 0.25pF	

PARTS LIST

Ref. No.	Parts No.	Description	Re- marks
Q10,11	V01-1015-06	TR 2SA1015(Y)	
Q12	V01-0671-16	TR 2SA671(B)	
Q13	V01-1015-06	TR 2SA1015(Y)	
Q14	V03-2603-06	TR 2SC2603(E)	
Q15	V03-0336-05	TR 2SC496(Y)	
Q16	V30-1135-06	IC FS7808C	
Q17,18	V03-2603-06	TR 2SC2603(E)	
Q19	V01-1015-06	TR 2SA1015(Y)	
Q20	V03-2603-06	TR 2SC2603(E)	
Q21,22	V03-1815-06	TR 2SC1815(Y)	
Q23,24	V03-0093-05	TR 2SC458(B)	
D1	V11-0317-05	Vari-cap diode 1S2208	
D2,3	V11-0414-05	Diode 1S2588	
D4	V11-0317-05	Vari-cap diode 1S2208	
D5~7	V11-7761-86	Vari-cap diode ITT410	
D8	V11-0076-05	Vari-cap diode 1S1555	
D9,10	V11-0051-05	Diode 1N60	
D11	V11-0076-05	Diode 1S1555	
D12	V11-1262-46	Diode VD1223	
D13	V11-0243-05	Zener diode WZ-061	
D14	V11-4167-06	Zener diode XZ-090	
D15,16	V11-0076-05	Diode 1S1555	
D17	V11-4101-20	Zener diode XZ-060	
D18	V11-4161-96	Zener diode XZ-070	
D19,20	V11-0076-05	Diode 1S1555	
D21	V11-4101-20	Zener diode XZ-060	
D22	V11-0076-05	Diode 1S1555 (W)(T)	
D22		not used (K)	
D23	V11-0076-05	Diode 1S1555 (T)	
D23		not used (K)(W)	
L1	L40-1545-06	Ferri-inductor 150mH	
L2	L77-0859-05	Crystal 10.710 MHz	
L3	L33-0615-05	Choke 15 μ H	
L4	L30-0005-05	Tuning coil	
L5	L31-0313-05	Tuning coil	
L6	L40-1001-03	Ferri-inductor 10 μ H	
L7	L40-1511-03	Ferri-inductor 150 μ H	
L8	L34-0886-05	Tuning coil MIX	
L9	L31-0180-05	Tuning coil	
L10	L31-0266-05	Tuning coil	
L11	L31-0267-05	Tuning coil	
L12	L34-0885-15	VHF Coil 5 ϕ 5T	☆
L13	L34-0452-05	VHF Coil 3 ϕ 6T	
L14	L34-0691-05	VHF Coil 5 ϕ 5T	
L15	L40-6825-04	Ferri-inductor 6.8mH	
L16	L33-0026-05	Choke 1 μ H	
L17	L15-0016-05	Choke trans.	
L18	L40-1511-03	Ferri-inductor 150 μ H	
L19,20	L40-1011-03	Ferri-inductor 100 μ H	
—	E40-0273-05	Mini connect wafer 2P	
—	E40-0373-05	Mini connect wafer 3P	
—	E40-0773-05	Mini connect wafer 7P	
—	E40-0873-05	Mini connect wafer 8P	
—	E40-1173-05	Mini connect wafer 11P	
—	E40-1273-05	Mini connect wafer 12P	

PACKING/DISASSEMBLY

< PACKING >

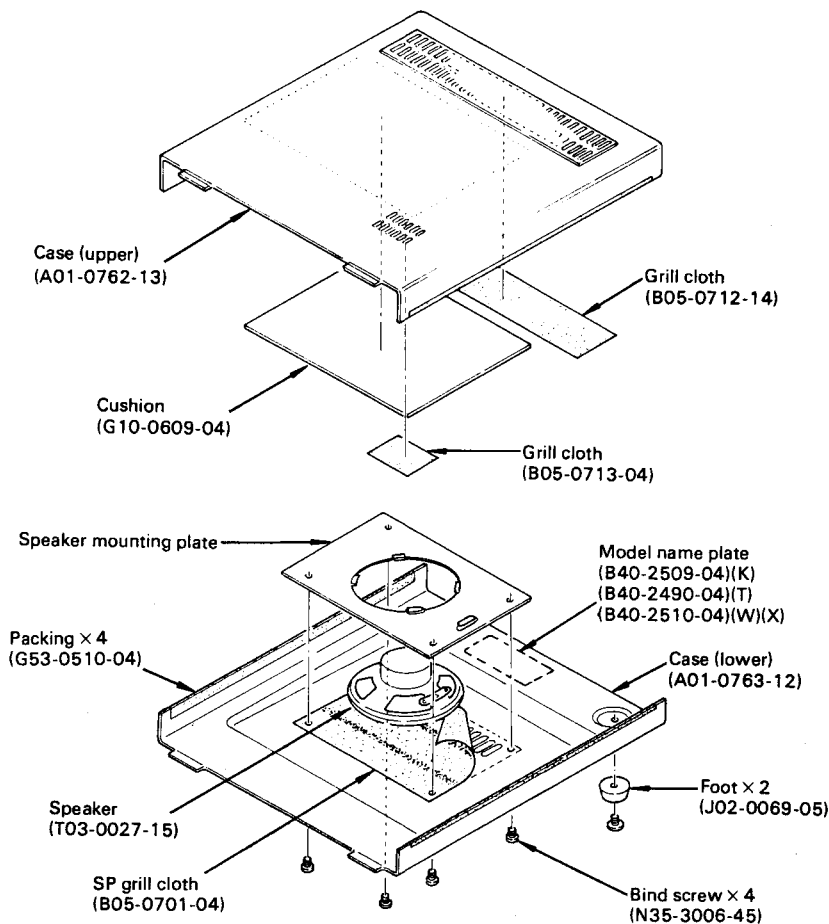
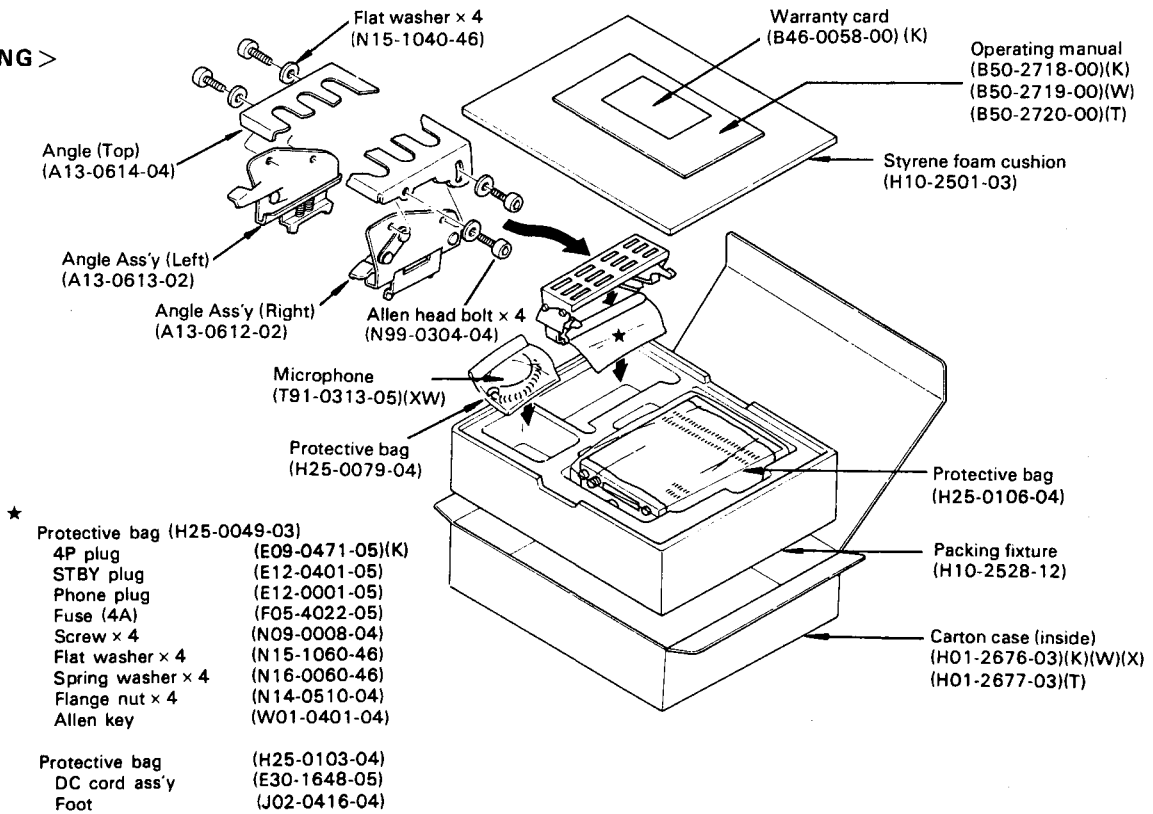
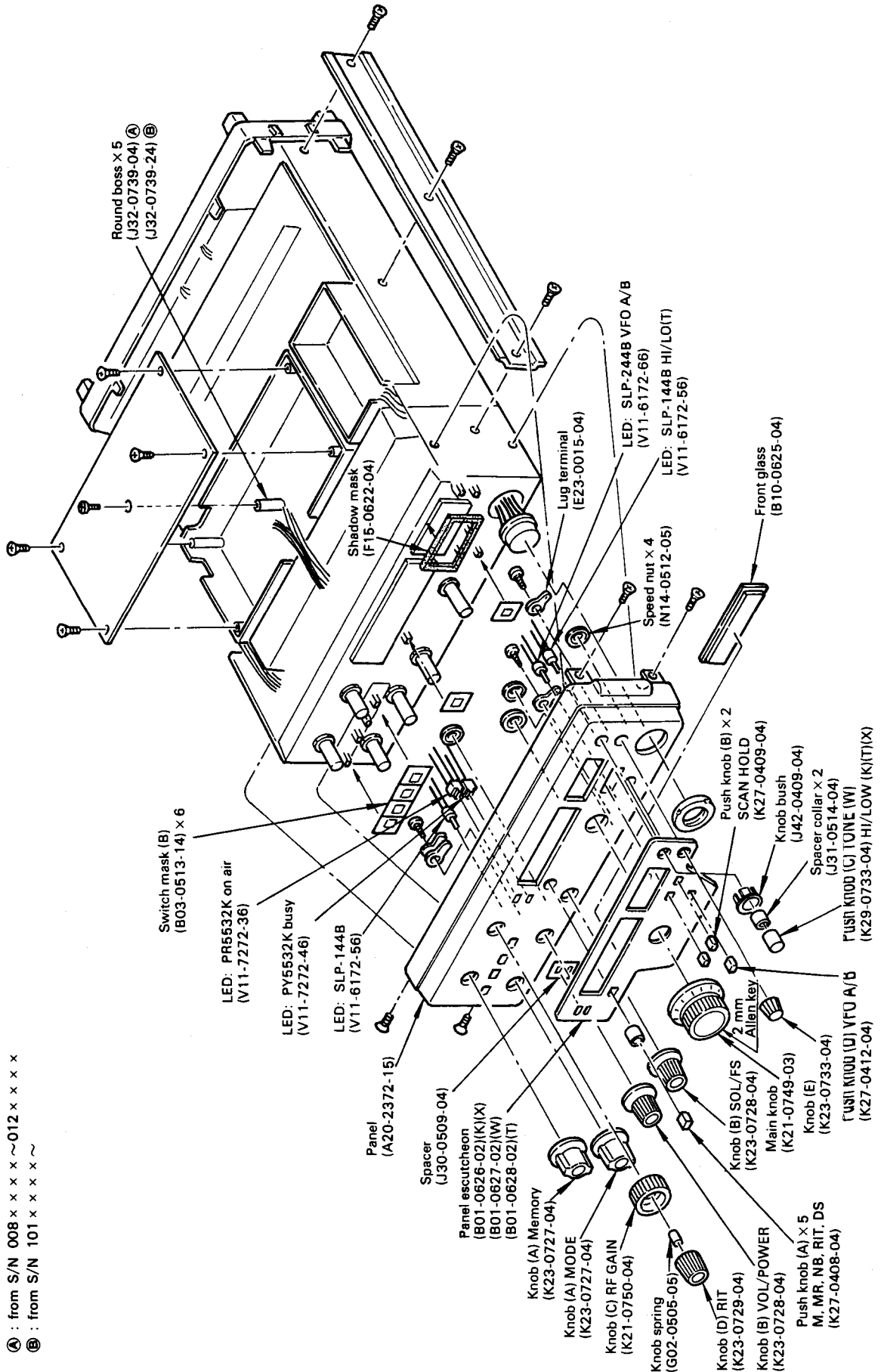

Fig. 12 Case disassembly

DISASSEMBLY



(A) : from S/N 008 x x x x ~ 012 x x x x x
 (B) : from S/N 101 x x x x x ~

Fig. 13 Front panel disassembly

DISASSEMBLY

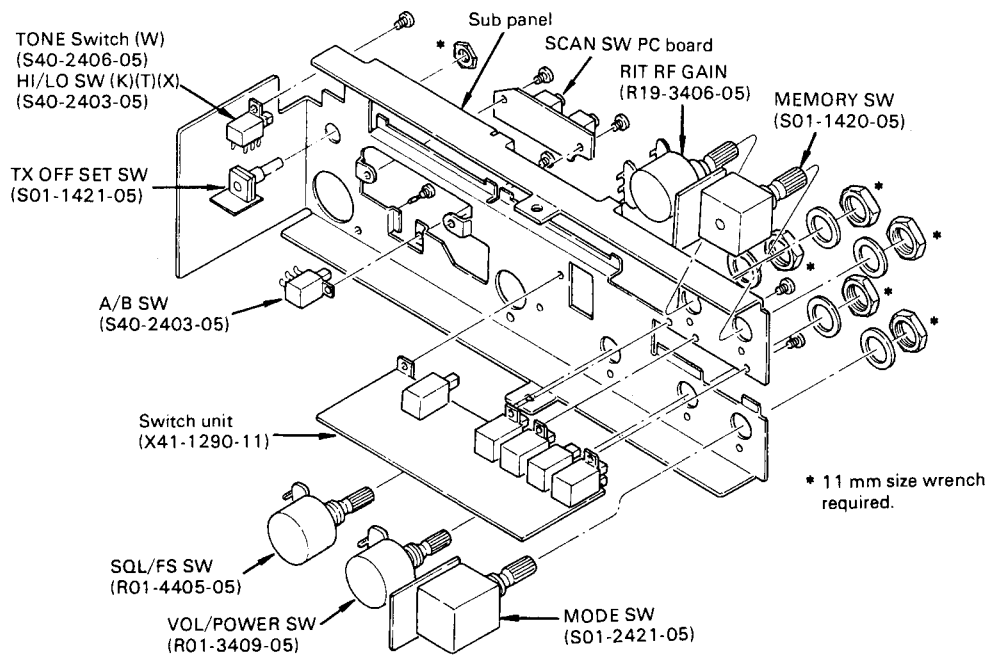

Fig. 14 Sub panel disassembly

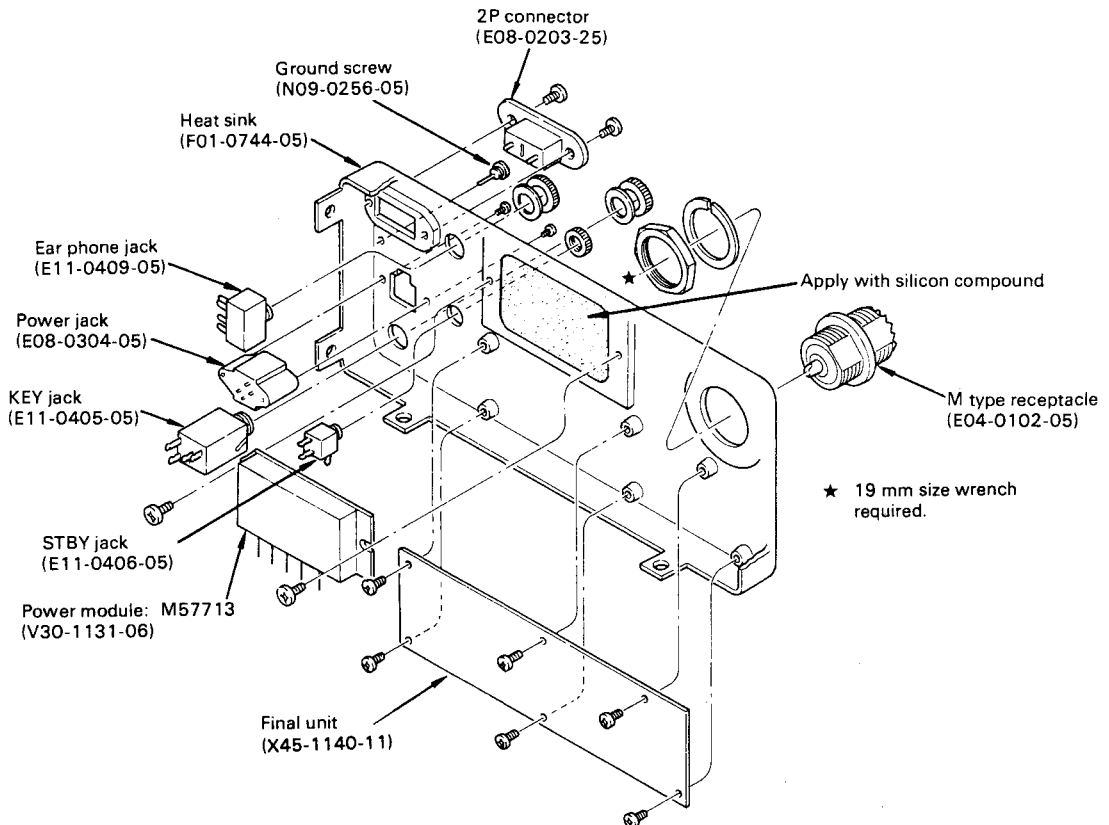

Fig. 15 Heat sink ass'y/disassembly

DISASSEMBLY

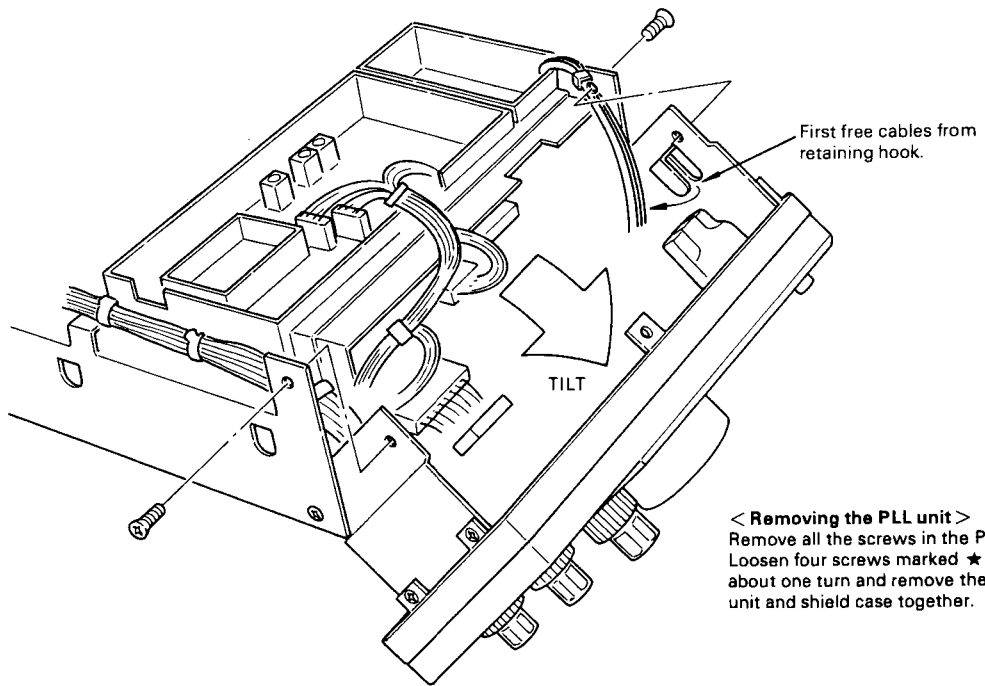

Fig. 16 Inspection of the PLL and switch unit

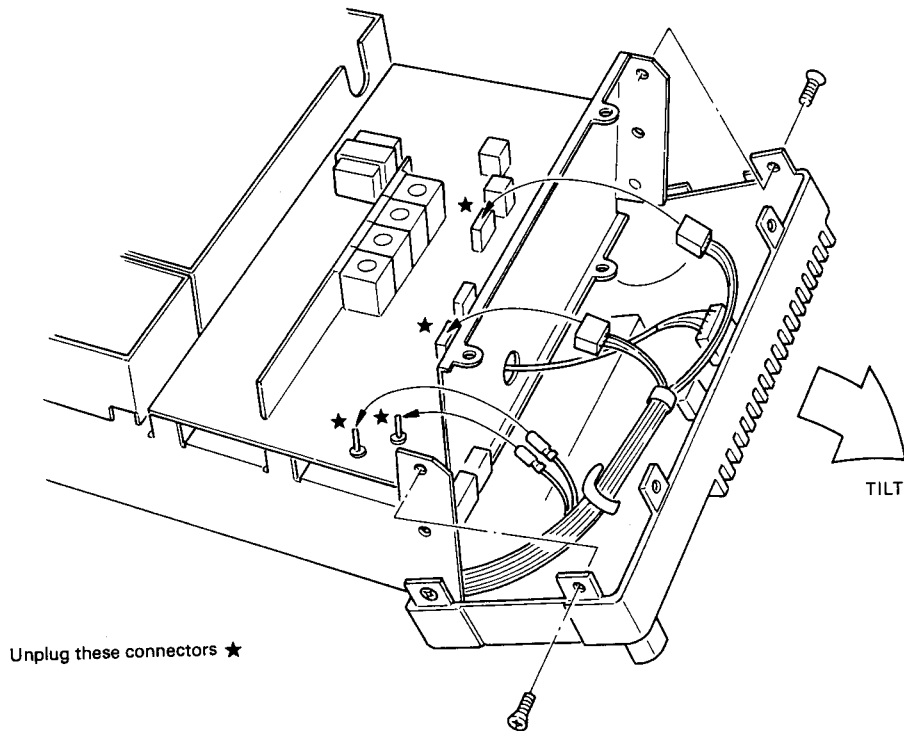
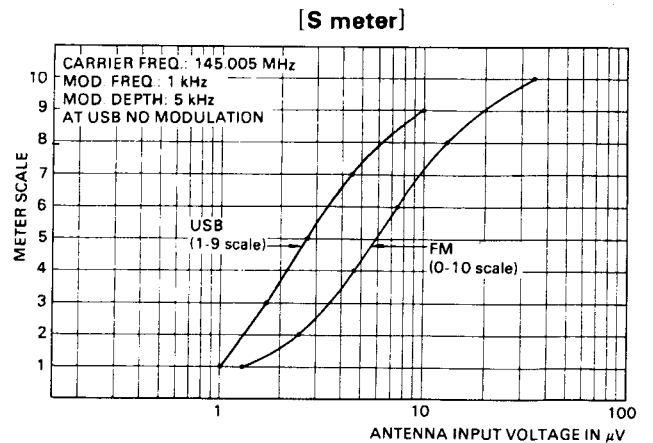
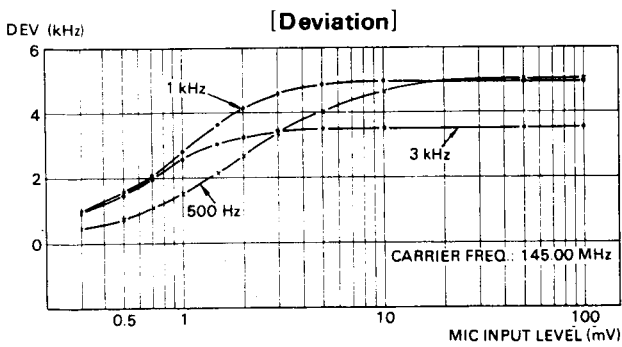
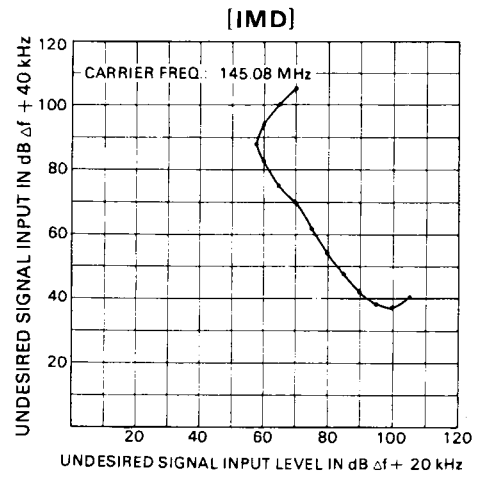
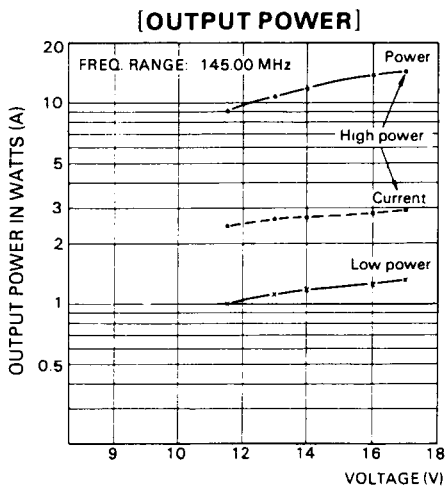
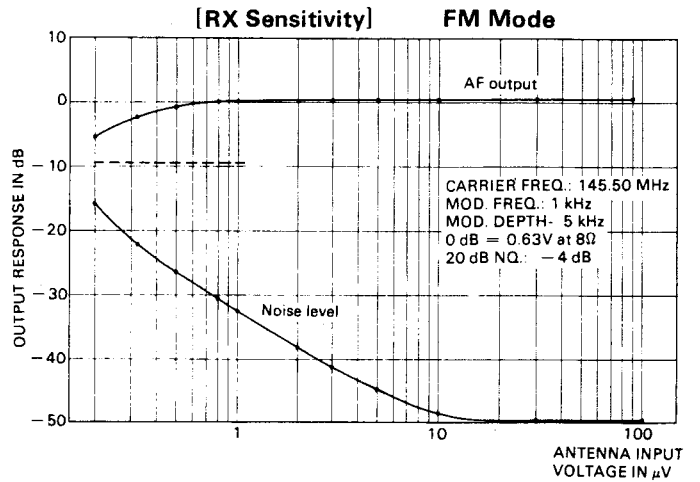
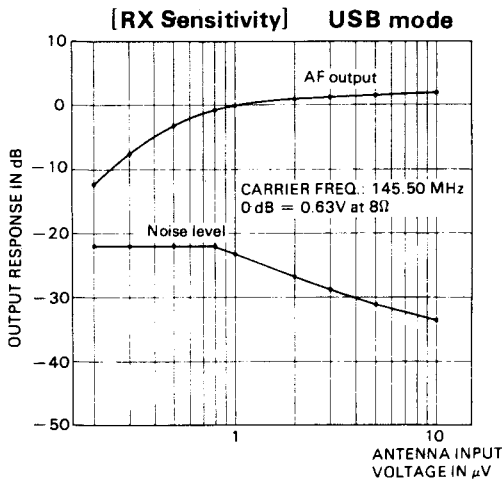
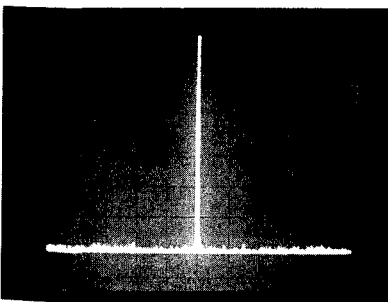

Fig. 17 Heat sink access

REFERENCE DATA



[Near spurious response]



CARRIER FREQ.: 145.02 MHz
RF POWER: 10.5W
SCAN WIDTH: 5 MHz/DIV
BAND WIDTH: 10 kHz
SCAN TIME: 0.5 sec.
VIDEO FILTER: 10 kHz
INPUT ATT: 20 dB
LOG REF LEVEL: -5 dBm
10 dB/DIV

[Harmonics spurious response]

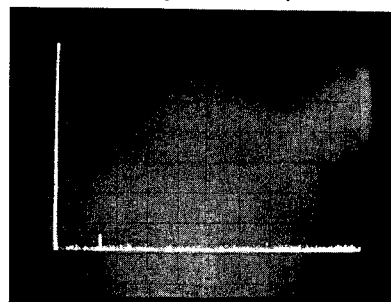

CARRIER FREQ.: 145.02 MHz
RF POWER: 10.5W
SCAN WIDTH: 100 MHz/DIV
BAND WIDTH: 30 kHz
SCAN TIME: 2 sec.
VIDEO FILTER: 10 kHz
INPUT ATT: 20 dB
LOG REF LEVEL: -5 dBm
10 dB/DIV

PS-20

PS-20 SPECIFICATIONS

[POWER SUPPLY SECTION]

Input voltage AC 120/220/240V $\pm 10\%$, 50/60 Hz
Output voltage DC 13.8V (standard voltage)
Output current 4.5A (intermittent load 50% duty cycle)
Continuous load current 4A max.
Output voltage fluctuation Within ± 50 mV at AC120/220/240V $\pm 10\%$
 (at load current 4A)
 Within 0.1V at 0~4A of load current
 (at AC 120/220/240V)
Ripple voltage Less than 5 mV at 13.8V, 4A
 (at AC 120/220/240V)
Power consumption Approx. 100W
 (at AC 120/220/240V, DC 13.8V, 4A)

[GENERAL]

Dimensions 123 (4-27/32") W \times 96 (3-25/32") H \times 235
 (9-17/64") D mm (inch)
Weight Approx. 3.8 kg (8.4 lbs)

[ACCESSORIES]

Operating manual 1
DC Power cord 1
Fuse (1A) 1
Crimp style terminal 2

NOTE: The circuit and ratings may change without notice due to development in technology.

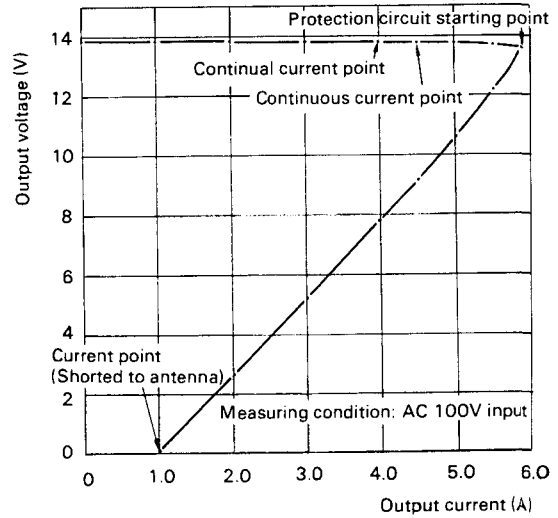

Fig. 19 Output voltage characteristic

PS-20

☆: New Parts

Ref. No.	Parts No.	Description	Re- marks
C1	C90-0808-05	E 15000 μ F 25V	☆
—	A01-0732-03	Case (A)	☆
—	A01-0733-02	Case (B)	☆
—	A20-2333-03	Panel (T)	☆
—	A20-2336-03	Panel (K)(W)	☆
—	B39-0407-04	Spacer (assistance leg)	
—	B46-0058-00	Warranty card (K)	
—	B50-2616-10	Operating manual (K)(W)	☆
—	B50-2617-10	Operating manual (T)	☆
—	E07-0252-05	2P Metal plug	
—	E20-0282-05	2P Terminal plate	☆
—	E23-0412-05	Crimp style terminal \times 2	☆
—	E30-0181-05	AC cord with plug (K)	
—	E30-0585-05	AC cord with plug (W)	
—	E30-0602-05	AC cord with plug (T)	
—	E30-1620-05	DC power cord	☆
—	F05-1023-05	Fuse (1A) \times 1 (K) \times 2(W)(T)	
—	F05-2023-05	Fuse (2A) \times 2(K)	
—	F29-0014-05	Shoulder washer \times 4	
—	H01-2592-14	Carton (inside) (K)(W)	☆
—	H01-2593-14	Carton (inside) (T)	☆
—	H10-2513-02	Styren foam cushion (front)	☆
—	H10-2514-02	Styren foam cushion (rear)	☆
—	H12-0460-04	Cushion	☆
—	H20-1407-03	Protective cover	☆
—	H25-0029-04	Accessories bag 60 \times 110 mm	
—	H25-0117-04	Accessories bag 80 \times 250 mm	
—	J02-0323-05	Foot \times 4	
—	J02-0409-04	Foot supporter	☆
—	J21-2573-04	Foot stopper \times 2	
—	J32-0133-04	Hex boss \times 4	
—	J41-0006-05	Cord bush (K)	
—	J41-0024-15	Cord bush (W)(T)	
—	L01-8056-05	Power trans.	☆

Ref. No.	Parts No.	Description	Re- marks
S1	S36-2402-05	Seesaw switch (power)	
S2	S31-2027-05	Slide switch (AC voltage)	
Q1.2	V04-0525-26	TR 2SD525(O) or (Y)	☆
D1	V11-2164-06	Rectifier stack M4B51-11	☆
—	X43-1350-00	AVR unit	☆

AVR UNIT (X43-1350-00)

Ref. No.	Parts No.	Description	Re- marks
C1.2	C91-0456-05	C 0.047 μ F 25V	
C3	CE04W1C100	E 10 μ F 16V	
C4.5	C91-0456-05	C 0.047 μ F 25V	
C6	CE04W1C222MA	E 2200 μ F 16V	☆
R14,15	R92-0618-05	Metal film 0.1 Ω	☆
VR1	R12-2015-05	Semi-fixed resistor 5k Ω	
VR2	R12-1016-05	Semi-fixed resistor 3k Ω	
Q1	V01-1015-06	TR 2SA1015(Y)	
Q2	V03-1959-06	TR 2SC1959 (Y)	
Q3	V01-0473-06	TR 2SA473(Y)	
Q4.5	V03-1815-06	TR 2SC1815(Y)	
D1	V11-4101-20	Zener diode XZ-060	
D2	V11-4161-76	Zener diode XZ-137	
D3	V11-4101-20	Zener diode XZ-060	
D4		not used	
D5	V11-0297-05	Zener diode WZ-130	
D6	V11-5160-66	LED SEL103R	☆
D7	V11-5160-76	LED SEL303G	☆
—	E23-0047-04	Square terminal \times 10	
—	J31-0503-05	Beads \times 4	

PS-20

PS-20 SCHEMATIC DIAGRAM

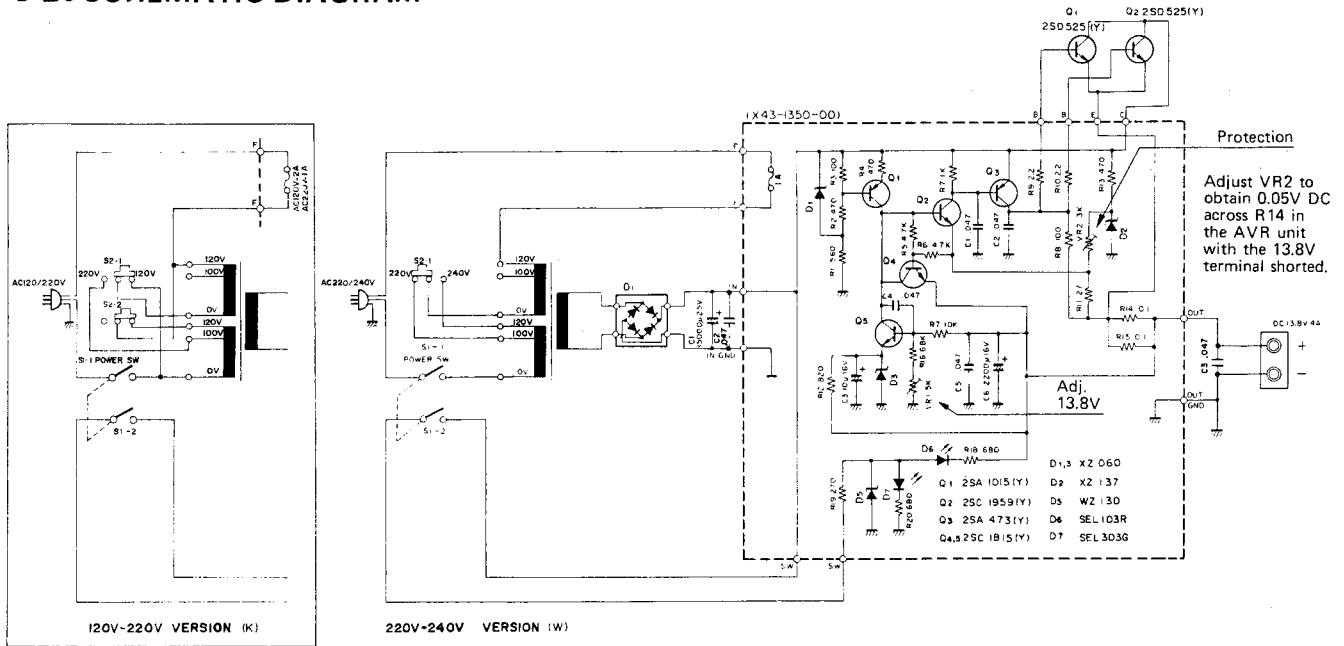

PS-20 PC BOARD ▼ AVR UNIT (X43-1350-00)

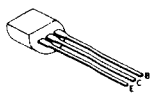
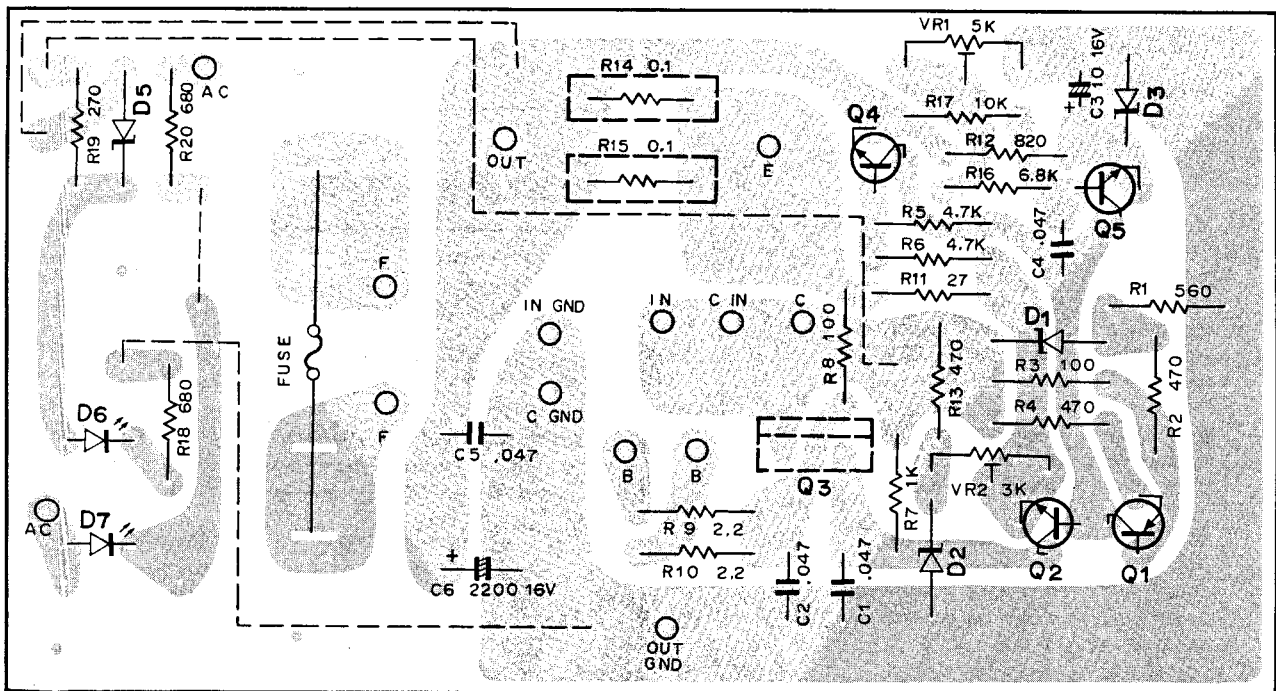

- 2SA1015(Y)
- 2SC1815(Y)
- 2SC1959(Y)

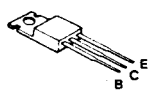

- 2SA473(Y)
- 2SD525(Y)

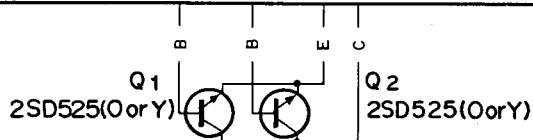

SYSTEM BASE BO-9

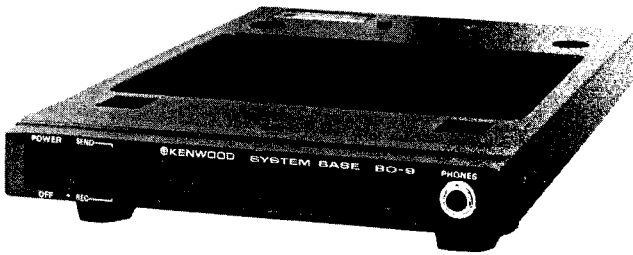

BO-9 SPECIFICATIONS

Input voltage AC120V (K) $\pm 10\%$, 50 ~ 60 Hz
 220~240V(T)(W)(X)
Buck up output DC13.8V, 1.5 mA
AC outlet output AC120V (K) 200W (MAX)
 220~240V(T)(W)(X)
Dimensions 170 (6-11/16") \times 25 (1") \times 232 (9-9/64") mm
 (inch)
Weights Approx. 1.0 kg (2.2 lbs)

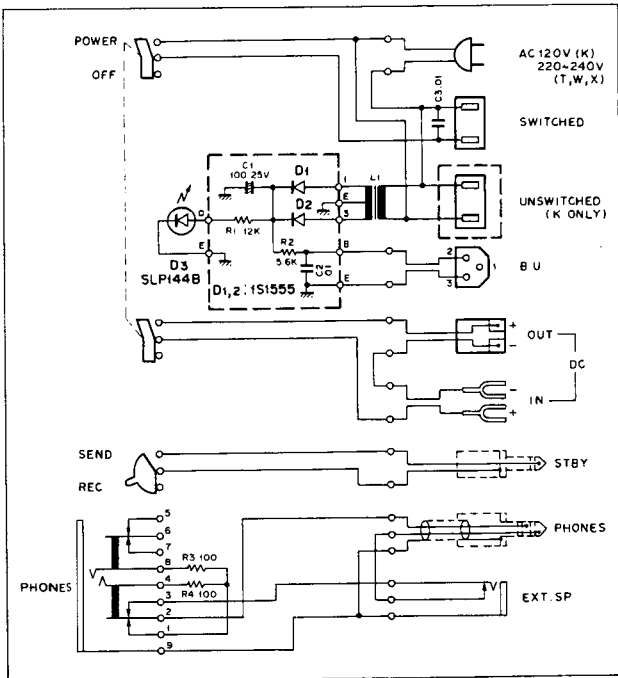

BO-9 PARTS LIST

Ref. No.	Parts No.	Description	Remarks
C1	CE04W1E101Q	E 100 μ F 25V	
C2,3	CK45F1H103Z	C 0.01 μ F +80,-20%	
R3,4	RC05GF2H101J	Solid 100 Ω $\pm 5\%$ 1/2W	
D1,2	V11-0076-05	Diode 1S1555	
D3	V11-6172-56	LED SLP144B	
—	A01-0767-02	Case (upper)(K)	☆
—	A01-0768-03	Case (bottom)	☆
—	A01-0769-02	Case (upper)(W)(T)(X)	☆
—	A20-2374-05	Panel (T)	☆
—	A20-2375-05	Panel (K)(W)(X)	☆
—	B46-0058-00	Warranty card (K)	
—	B50-2708-00	Operating manual (K)	☆
—	B50-2709-00	Operating manual (W)(T)(X)	☆
—	E03-0153-05	AC Outlet	☆
—	E03-0154-05	AC Plug (W)(T)(X)	☆
—	E11-0404-05	Phone jack	
—	E11-0410-05	Phone jack	☆
—	E22-0306-05	Lug plate	
—	E30-0181-05	AC cord (K)	
—	E30-0185-05	AC cord (X)	
—	E30-0585-05	AC cord (W)	
—	E30-0602-05	AC cord (T)	
—	E30-1653-15	DC cord	☆
—	E30-1654-05	Cord with $\phi 2.5$ plug	☆
—	E30-1655-05	Cord with ST plug	☆
—	E30-1656-05	DC cord ass'y	☆
—	E30-1657-05	3P power cord BACK UP	☆
—	H01-2665-04	Carton (inside)(T)	☆
—	H01-2667-04	Carton (inside)(K)(W)(X)	☆
—	H10-2532-04	Cushion foam $\times 4$	☆
—	H12-0467-03	Cushion	☆
—	H25-0029-04	Protective bag (W)(T)(X)	
—	H25-0103-04	Protective bag 125 \times 250 mm	
—	H25-0106-04	Protective bag 250 \times 350 mm	
—	J02-0323-05	Foot $\times 4$	
—	J19-1325-04	Stopper plate $\times 4$	
—	J25-2732-04	PC board	☆
—	J41-0006-05	Cord bush	
—	L01-0150-05	Transformer (K)	
—	L01-8022-05	Transformer (W)(T)(X)	☆
—	N35-3004-45	Bind screw	
—	N35-3006-45	Bind screw	
—	S36-2405-05	Power switch	☆
—	S44-2404-05	STBY switch	☆

LEVEL DIAGRAM

< RECEIVER SECTION >

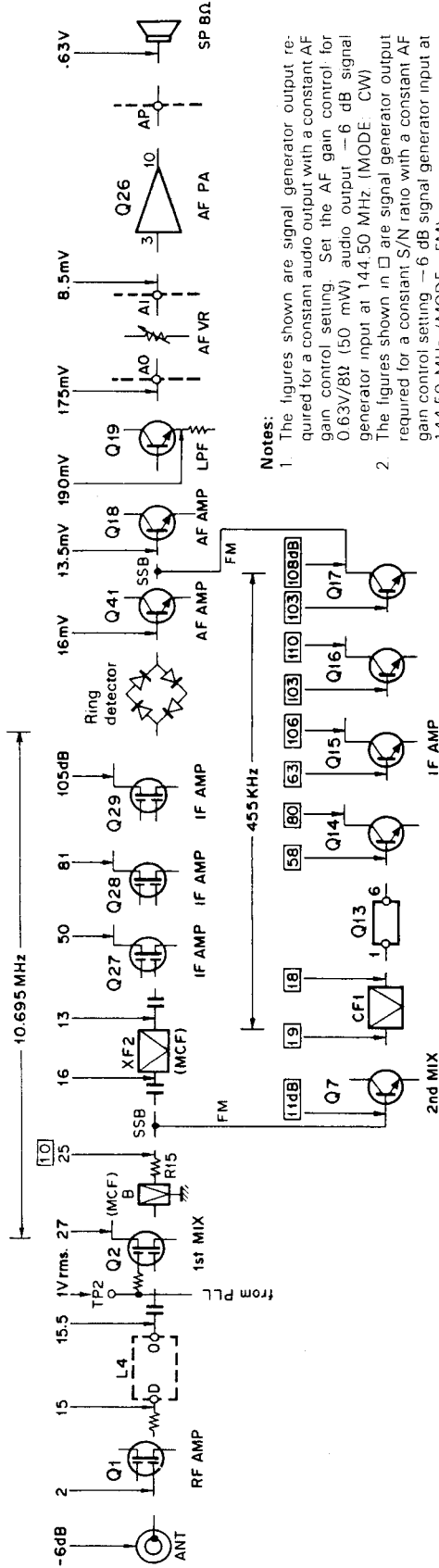

Notes:

1. The figures shown are signal generator output required for a constant audio output with a constant AF gain control setting. Set the AF gain control for 0.63V/8Ω (50 mW) audio output -6 dB signal generator input at 144.50 MHz. (MODE: CW)
2. The figures shown in □ are signal generator output required for a constant S/N ratio with a constant AF gain control setting -6 dB signal generator input at 144.50 MHz. (MODE: FM)
3. The figures shown after the ring detector are audio output levels.
4. To inject signal generator output connect a 0.01 μF 500V capacitor between the signal generator and the check point.

< TRANSMITTER SECTION >

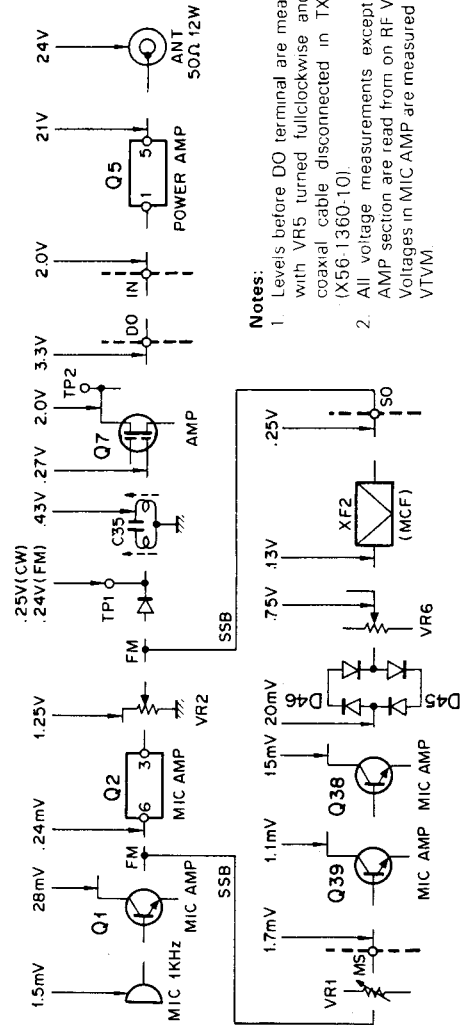

Notes:

1. Levels before DO terminal are measured with VR5 turned fullclockwise and DO coaxial cable disconnected in TX unit (X56-136Q-10).
2. All voltage measurements except MIC AMP section are read from on RF-VTVM. Voltages in MIC AMP are measured by AF-VTVM.

< REFERENCE >

Japanese "SG"	American "SG"
-6 dB	0.25 μV
0 dB	0.5 μV
6 dB	1 μV
12 dB	2 μV
24 dB	8 μV
30 dB	15.8 μV
40 dB	50 μV
50 dB	158 μV
60 dB	500 μV
70 dB	1.58 mV
80 dB	5 mV
90 dB	15.8 mV
100 dB	50 mV
120 dB	0.5V

ADJUSTMENTS

< Test Equipment >

1. Tester
 - Input: Sufficient
 2. RF VTVM (RF V.M.)
 - Input impedance: 1 M Ω and less than 2 pF
 - Voltage range: F.S. = 10 mV to 300V
 - Frequency range: 150 MHz or greater
 3. Frequency counter (F count)
 - Minimum input voltage: 50 mV
 - Frequency range: 150 MHz or greater
 4. DC power supply
 - Voltage 10V to 17V variable
 - Current: 6A min.
 5. RF Dummy Load
 - Dissipation: 20W
 - Impedance: 50 Ω
 - Frequency range: 144 MHz
 6. AF VTVM (AF V.M.)
 - Input impedance: 1 M Ω or greater
 - Voltage range: F.S = 1 mV to 30V
 - Frequency range: 50 Hz to 10 kHz
 7. AF Generator (AG)
 - Frequency range: 100 Hz to 10 kHz
 - Output: 0.5 mV to 1V
 8. Linear detector
 - Frequency range: 144 MHz
 9. Field strength tester
 - Frequency range: 144 MHz
 10. Directional coupler
 11. Oscilloscope
 - With horizontal input and high sensitivity
 12. Standard signal generator (SSG)
 - Frequency range: 144 ~ 149 MHz
 - Modulation: amplitude and frequency modulation
 - Output: -20 dB ~ 100 dB
 13. AF Dummy load
 - 8 Ω , 5W (approx.)
- Noise generator
- Must generate ignition-like noise containing harmonics beyond 144 MHz
15. Sweep generator
 - Frequency range: 144 ~ 149 MHz

< Preparation >

Unless otherwise specified, set the controls as follows.

POWER/VOL SW	ON
SEND/REC	REC
RF GAIN VOL	MAX (Full Clockwise)
SQUELCH VOL	MIN
MODE SW	USB
VFO A/B SW	A
TX OFF SET SW	S
HI/LOW SW	HI
RIT VOL	Centered
RIT SW	OFF
NB SW	OFF
SCAN SW	OFF
D.STEP/SEARCH	OFF
MR	OFF

Notes:

- When adjusting the trimmers or coils, use a non-induced adjusting rod of bakelite, etc.
- When adjusting the RX section never transmit to prevent SSG damage.
- Connect MIC connector as shown in Fig. 18.

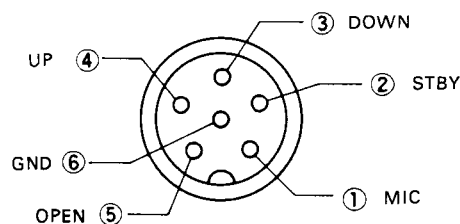

Fig. 18 MIC terminals
(view from front panel side)

ADJUSTMENTS

Item	Condition	Measurement			Adjustment			Specification	Remarks
		Test equipment	Unit	Terminal	Unit	Parts	Method		
1. Voltage check in RX mode.	1 8C	DC V.M	TX	8C				7.7~8.3V	Check
	2 8R			8R				7.9~8.9V	
	3 9T			9T				Less than 0.1V	
	4 -6 Mode SW : FM1			-6 -6				-5.8~-6.2V 0V (Voltage drops)	
	5 5C			PLL	5C				
2. Voltage check in TX mode	• Disconnect TX unit DO-E cable • Set in transmit mode.	DC V.M	TX	9T	TX	VR6	Set to 9.0±0.1V		Check
	1 9T			8R				Less than 0.5V	
	2 8R			Final	DB			11.7~12.1V	
3. Back up voltage check	1 POWER/VOL SW: OFF	DC V.M	TX	MB	TX	VR7	Set to 5.2±0.1V		
4. PLL	1 MODE SW: FM1 VFO dial: 8.99 (K.X) 5.98 (W.T)	RF V.M	PLL	TP3	PLL	L5,6,7	MAX		Reference 0.5V
	2 VFO dial: 4.00 (W.T) 8.99 (K.X)	DC V.M	PLL	TP2	PLL	TC1	2.0V (W.T) 7.0V (K.X)	±0.05V	
	3 VFO dial: 8.99 (K.X) 5.98 (W.T)	RF V.M	PLL	TP3	PLL	L5,6,7	MAX		Readjust 1
	4 VFO dial: 5.98 (W.T) 4.00 (K.X)	DC V.M	PLL	TP2				3.5~4.5V (W.T) More than 2.0V (K.X)	Check
	5 VFO dial: 5.00 Set in transmit mode MODE SW: USB	RF V.M	PLL	TP1	PLL	L4	MAX		Reference 0.2V
5. HET frequency adjustment	1 Set in receive mode. MODE SW: FM2 VFO dial: 6,000.0 (K.X) 5,000.0 (W.T)	F.counter	PLL	TP1	Switch	VR2	135,305 MHz (K.X) 134,305 MHz (W.T)	±20 Hz	
	2 MODE SW: USB VFO dial: 6,000.0 (K.X) 5,000.0 (W.T)	F. counter	PLL	TP1	Switch	VR3	135,306.5 MHz (K.X) 134,306.5 MHz (W.T)	±10 Hz	
	3 VFO dial: 5,999.9 (K.X) 4,999.9 (W.T)	F.counter	PLL	TP1	PLL	VR1,2	135,306.4 MHz (K.X) 134,306.4 MHz (W.T)	±10 Hz	VR1: Coarse VR2: Fine
	4 MODE SW: LSB VFO dial: 6,000.0 (K.X) 5,000.0 (W.T)	F.counter	PLL	TP1	Switch	VR1	135,303.5 MHz (K.X) 134,303.5 MHz (W.T)	±20 Hz	
6. RIT	1 MODE SW: LSB VFO dial: 5,000.0 RIT SW: ON	F.counter	PLL	TP1	Switch	VR4	134,303.5 MHz	±10 Hz	
	2 MODE SW: USB	F.counter	PLL	TP1	Switch	VR5	134,306.5 MHz	±10 Hz	
	3 RIT control: Full clockwise RIT control: Full counterclockwise	F.counter	PLL	TP1				More than 134,307.5 MHz Less than 134,305.5 MHz	More than ±1.0 kHz Less than -1.0 kHz
	4 RIT SW: OFF RIT control: Centered	DC V.M	PLL	RIT				5.0±0.3V	Check

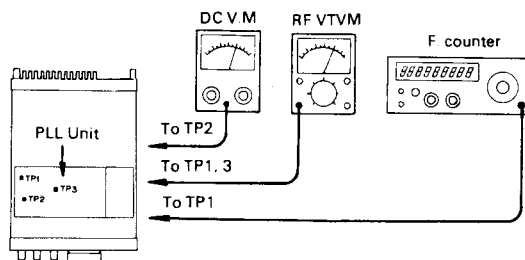

Fig. 19 4. PLL, 5. HET, 6. RIT

ADJUSTMENTS

Item	Condition	Measurement			Adjustment			Specification	Remarks
		Test equipment	Unit	Terminal	Unit	Parts	Method		
7. CAR	1 Set knobs in Table 10.	RF V.M	CAR	TP	CAR	L4	MAX		Reference 0.28V
	2	F.counter	CAR	TP	CAR	TC1	10.693.5 MHz	±50 Hz	
	3 MODE SW: CW	F.counter	CAR	TP				Same frequency as 2	Check
	4 Set in transmit mode.	F.counter	CAR	TP	CAR	TC2	10.694.3 MHz	±50 Hz	
	5 Set in receive mode. MODE SW: LSB	F.counter	CAR	TP	CAR	TC3	10.696.5 MHz	±50 Hz	

< RX SECTION >

Item	Condition	Measurement			Adjustment			Specification	Remarks
		Test equipment	Unit	Terminal	Unit	Parts	Method		
1. RG1 voltage	1 MODE SW: FM2 VFO dial: 6,000.0 (K.X) 5,000.0 (W.T)	DC V.M	RX	RG1	RX	VR1	4.0V		
2. Helical	1 VFO dial: 5,000.0 (W.T) 6,000.0 (K.X)	RF V.M	RX	TP2	RX	L3	MAX	146 MHz(K.X) 145 MHz(W.T)	Reference 1.0V
	2 ANT terminal on rear panel: Connect sweep generator. TP1 on RF unit: Connect detector. LR-E connector: Disconnect. Reconnect after adjustment.	Oscilloscope < Detector > RX To RF unit TP1 To Oscilloscope vertical			L1,2 TC101 102.103	Repeat		144MHz 148 MHz(K.X) 146 MHz(W.T)	

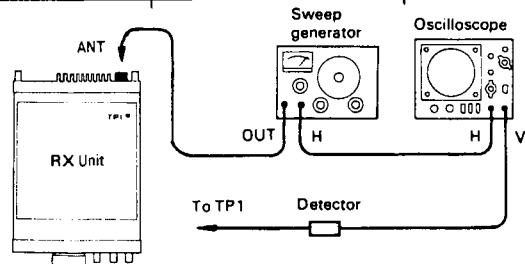

Fig. 20 RX 2. Helical

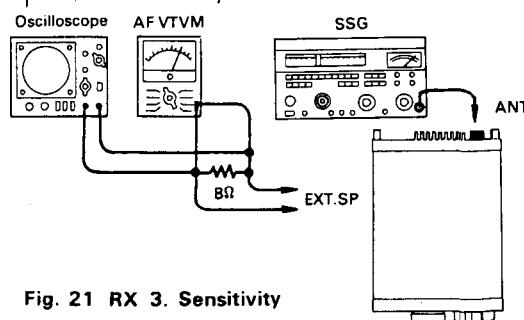

Fig. 21 RX 3. Sensitivity

3. Sensitivity adjustment	1 ANT terminal on rear panel: Connect SSG. VFO dial: 6,005.0 (K.X) 5,005.0 (W.T) Set SSG to 146.005 MHz (K.X), 145.005 MHz (W.T), 10 dBμ (unmodulated). Adjust the level so that the S meter deflects. AF GAIN: 0.63V/8Ω (50 mW)	S meter or AF V.M.	Rear panel	EXT.SP	RX	L5,6,8,19	MAX (Repeat)		Repeat this adjustment as L6, 8 and 19 interct.
	2	AF V.M.	Rear panel	EXT.SP	RX	L8	Turn core counter-clockwise to reduce AF output by 2 dB.		
	3	AF V.M.	Rear panel	EXT.SP	RX	L19,20 21,22	MAX		
	4 SSG OUT: -8 dBμ	AF V.M.	Rear panel	EXT.SP				S/N more than 10 dB	Check
	5 MODE: FM2 VFO dial: 6,005.0 (K.X) 5,005.0 (W.T) Adjust SSG signal so the S meter indicates "3"	S meter or AF V.M.	Rear panel	EXT.SP	RX	L3,5~7	MAX (Repeat)		Repeat this adjustment as L6 and 7 interct.



ADJUSTMENTS

Item	Condition	Measurement			Adjustment			Specification	Remarks
		Test equipment	Unit	Terminal	Unit	Parts	Method		
	6 SSG OUT: 50 dB μ	AF V.M.	Rear panel	EXT.SP	RX	L17	MAX		
	7 SSG OUT: -7 dB μ	AF V.M.	Rear panel	EXT.SP				S/N more than 20 dB	Check
	8 SSG OUT: 40 dB μ	AF V.M.	Rear panel	EXT.SP				S/N more than 50 dB	Check
4. S meter	1 MODE SW: FM2 SSG OUT: 30 dB μ	S meter			RX	VR2	Set RF meter to "10"		Lower scale
	2 MODE SW: USB No signal	S meter			RX	VR4	Set RF meter to "0"		Lower scale
	3 VFO dial: 4.500.0 SSG OUT: 20 dB μ	S meter			RX	VR5	Set S meter to "9"		Upper scale
	4 SSG OUT: 0 dB μ	S meter			RX	L21	After adjusting to MAX, turn the core counter-clockwise to set S meter to "1"		Upper scale
	5 Again SSG OUT: 20 dB μ	S meter			RX	VR5	Set S meter to "9"		Upper scale
5. NB	1 SSG OUT: 20 dB	DC V.M.	RX	TP3	RX	L12.14	MIN (Repeat)		When TP3 voltage is less than 5V adjust L14 counter-clockwise to get 5V.
	2 Pulse noise							Pulse noise should be reduced.	Check

< TX SECTION >

Item	Condition	Measurement			Adjustment			Specification	Remarks
		Test equipment	Unit	Terminal	Unit	Parts	Method		
1. CAR level	1 TX unit VR5: Full clockwise (ALC OFF) DO terminal: Disconnect coaxial cable. VFO dial: 5.005.0 Set in transmit mode.	RF V.M.	RX	SO	RX	L25	MAX		
					RX	VR7	0.25V		
2. FM 10.695 MHz	1 Follow the above procedures.	RF V.M.	TX	TP1	TX	L5	MAX		Reference 0.25V
	2 MODE SW: FM1	RF V.M.	TX	TP1	TX	L4	MAX		Reference 0.25V
	3	F.counter	TX	TP1	TX	TC1	10.695 MHz	± 200 Hz	
3. Drive adjustment.	1 Follow the above procedures.	RF V.M.	TX	TP2	TX	L8~11	MAX (Repeat)		Reference 2.3V
4. Power adjustment.	1 ANT terminal on rear panel: Connect power meter. DO terminal: Connect coaxial cable. Set in transmit mode.	Power meter or DC A.M.			TX	L11 TC2	MAX (Repeat)		
		Power meter			TX	TC3	MAX		More than 15W

ADJUSTMENTS

Item	Condition	Measurement			Adjustment			Specification	Remarks
		Test equipment	Unit	Terminal	Unit	Parts	Method		
	2	DC V.M	Final	TP	Final	VR3	MIN		Reference 0.3V
	3	Power meter			TX	VR5	Set to 11W		
5. RF meter	1 Follow the above procedures.	RF meter			Final	VR1	Set RF meter to "8"		Lower scale
6. LOW power	1 Follow the above procedures. HI/LOW SW: LOW MODE SW: FM1-FM2-CW	Power meter			TX	VR4	Set to 1.2W		
7. Protection	1 MODE SW: FM1 HI/LOW SW: HI ANT terminal on rear panel: open	DC V.M	TX	PC	Final	VR2	1.25V	Current less than 1.8A	RF meter deflection should be below that at 50 ohm termination.
	2 Current above 1.8A.				Final	VR2	Set to 1.8A.		
8. FM deviation	1 MODE SW: FM1 MIC terminal: Connect AG signal of 1 kHz, 15mV.	Linear detector			TX	VR2	Set to 5 kHz		
	2 AG: Adjust AG output to obtain 3.5 kHz deviation.	AF.V.M.						AG output: less than 3 mV	Check

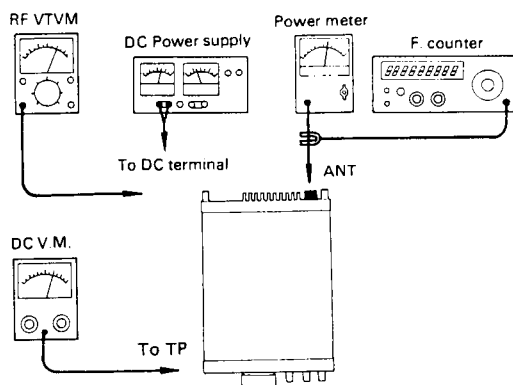

Fig. 22 TX 4. Power adjustment

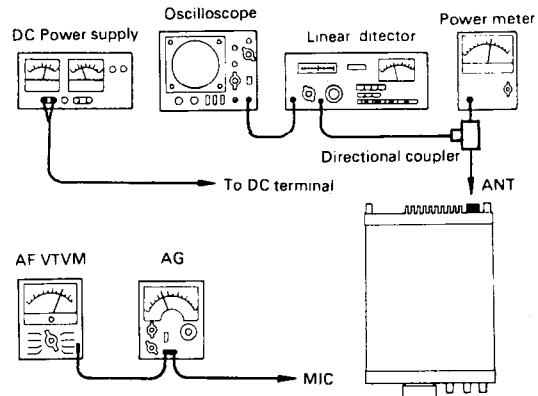

Fig. 23 TX 8. FM deviation

9. SSB MIC gain	1 MODE SW: USB VFO dial: 4,500.0 AG: 1.5 kHz, 1.5 mV	Power meter			TX	VR1	10W	$\pm 0.5W$	
10. Carrier point	1 Adjust AUDIO output level for 5W of transmit output	Power meter							
	2 AG: 400 Hz or 2,600 Hz	Power meter			CAR	TC1	400/2,600 Hz alternate	Same output	
	3 MODE SW: LSB	Power			CAR	TC3	400/2,600 Hz alternate	Same output	
11. CAR Suppression	1 MODE SW: USB MIC terminal: Terminated with 470 ohm	Field strength meter			RX	TC1 VR6	Adjust alternately to minimize the field strength meter deflection.	Less than -40 dB	
12. Side tone level	1 MODE SW: CW AF VOL: Centered Key jack: Connect key and depress.	AF V.M		EXT.SP	RX	VR3	50 mW (0.63V/8 Ω)		
Check of operating frequency.	1 MODE SW: FM2 VFO dial: 6,000.0 (K.X) 5,000.0 (W.T)	F.counter	PLL	TP1				135,305.0 MHz ± 20 Hz (K.X) 134,305.0 MHz ± 20 Hz (W.T)	Check

ADJUSTMENTS

Item	Condition	Measurement			Adjustment			Specification	Remarks
		Test equipment	Unit	Terminal	Unit	Parts	Method		
Check of operating frequency	2 MODE SW: USB VFO dial: 6,000.0 (K.X) 5,000.0 (W.T)	F.counter	PLL	TP1				135,306.5 MHz ±10 Hz (K.X) 134,306.5 MHz ±10 Hz (W.T)	Check
	3 MODE SW: LSB VFO dial: 6,000.0 (K.X) 5,000.0 (W.T)	F.counter	PLL	TP1				135,303.5 MHz ±10 Hz (K.X) 134,303.5 MHz ±10 Hz (W.T)	Check
	4 VFO dial: 5,999.9 (K.X) 4,999.9 (W.T)	F.counter	PLL	TP1				135,303.4 MHz ±10 Hz (K.X) 134,303.4 MHz ±10 Hz (W.T)	Check
	5 Set in receive mode								

< Micro-computer operational check >

Control functions	Micro-computer functions																				
1. VFO A/B 1 Disconnect power plug and re-connect after a 20 second delay. 2 VFO A/B SW: B 3 MR SW: ON MEMORY: 1 ~ 5 4 VFO A/B SW: A MR SW: OFF 2. Dial step and indicator digits <table border="1" style="width: 100%; border-collapse: collapse; margin-top: 5px;"> <thead> <tr> <th style="text-align: center;">Destination Display, dial step</th> <th style="text-align: center;">K</th> <th style="text-align: center;">X</th> <th style="text-align: center;">W</th> <th style="text-align: center;">T</th> </tr> </thead> <tbody> <tr> <td>MODE SW: USB-CW-LSB-FM2 Turn VFO dial</td> <td style="text-align: center;">5 digits indication Indication changes in 100 Hz steps.</td> <td style="text-align: center;">←</td> <td style="text-align: center;">←</td> <td style="text-align: center;">←</td> </tr> <tr> <td>MODE SW: FM2 D. STEP SW: ON Turn VFO dial.</td> <td style="text-align: center;">4 digits indication Indication changes in 5 kHz steps.</td> <td style="text-align: center;">←</td> <td style="text-align: center;">4 digits indication Indication changes in 12.5 kHz steps</td> <td style="text-align: center;">←</td> </tr> <tr> <td>MODE SW: FM1 D. STEP SW: ON, OFF Turn VFO dial.</td> <td style="text-align: center;">3 digits indication Indication changes in 10 kHz steps.</td> <td style="text-align: center;">4 digits indication Indication changes in 25 kHz steps.</td> <td style="text-align: center;">←</td> <td style="text-align: center;">←</td> </tr> </tbody> </table>	Destination Display, dial step	K	X	W	T	MODE SW: USB-CW-LSB-FM2 Turn VFO dial	5 digits indication Indication changes in 100 Hz steps.	←	←	←	MODE SW: FM2 D. STEP SW: ON Turn VFO dial.	4 digits indication Indication changes in 5 kHz steps.	←	4 digits indication Indication changes in 12.5 kHz steps	←	MODE SW: FM1 D. STEP SW: ON, OFF Turn VFO dial.	3 digits indication Indication changes in 10 kHz steps.	4 digits indication Indication changes in 25 kHz steps.	←	←	Indicates 6,000.0 (K.X) Indicates 5,000.0 (W.T) Indicates 4,000.0. VFO B indicator lights. Indicates 4,000.0.
Destination Display, dial step	K	X	W	T																	
MODE SW: USB-CW-LSB-FM2 Turn VFO dial	5 digits indication Indication changes in 100 Hz steps.	←	←	←																	
MODE SW: FM2 D. STEP SW: ON Turn VFO dial.	4 digits indication Indication changes in 5 kHz steps.	←	4 digits indication Indication changes in 12.5 kHz steps	←																	
MODE SW: FM1 D. STEP SW: ON, OFF Turn VFO dial.	3 digits indication Indication changes in 10 kHz steps.	4 digits indication Indication changes in 25 kHz steps.	←	←																	
3. Memory 1 Write Set the controls as in Table 10. MEMORY SW: 1 ~ 5 2 Call MEMORY SW: 1 ~ 5 3 MEMORY SW: 5	By pressing M SW, tone should be heard and the 5-digit data indicated should be stored in memory. By pressing MR SW, the 5-digit frequency should be displayed. Transmit and receive frequencies should be stored and called individually.																				
4. UP/DOWN 1 Set the controls as in Table 10.	Press the MIC UP/DOWN switch once, the tone should be heard and the frequency will shift up or down step by step. Press and hold the switch, and the frequency will change rapidly with continuous tone.																				
5. Search 1 MODE SW: USB-CW-LSB D. STEP SW: ON (SEARCH) 2 Turn VFO dial. 3 Set in transmit mode. 4 D. STEP SW: OFF Set in receive mode.	The frequency is searched between 0 and 9.9 kHz in 100 Hz steps. The frequency is shifted up or down in 10 kHz steps (quick shift). The search function stops.																				
6. Scan 1 MODE SW: FM2 Squelch control: ON SCAN SW: ON 2 D. STEP SW: ON (SEARCH) 3 Squelch control: Turn counterclockwise. 4 Squelch control: F.S. 5 Set in transmit mode. 6 Set in receive mode.	The frequency is shifted up in 100 Hz steps. The frequency is shifted up in 5 kHz (K.X), 12.5 kHz (W.T) steps. BUSY indicator lights. Scan stops. Scan restarts. Scan stops.																				

ADJUSTMENTS

< TOP INTERNAL VIEW >

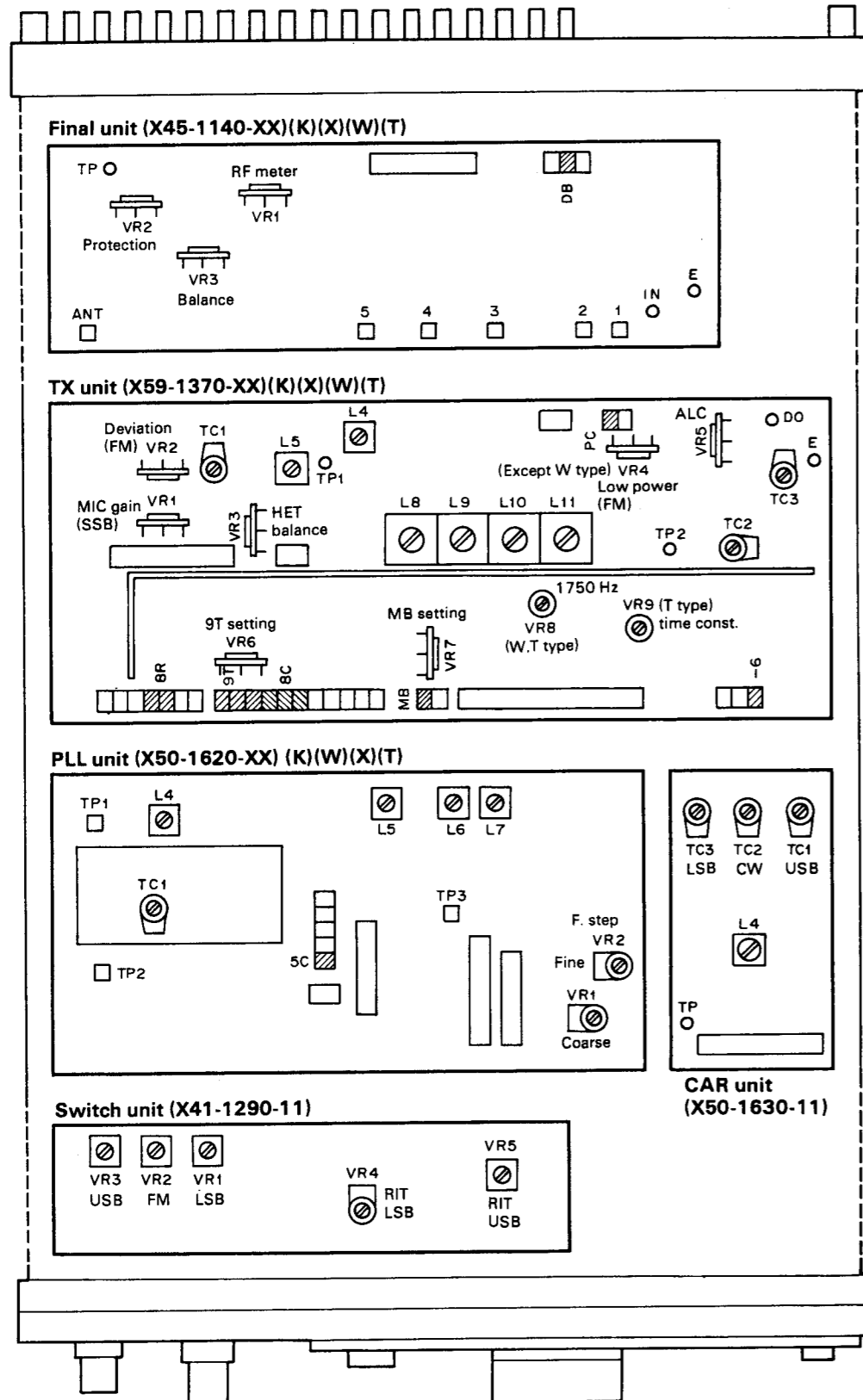

ADJUSTMENTS

RX unit (X55-1260-XX)(K)(X)(W)(T)

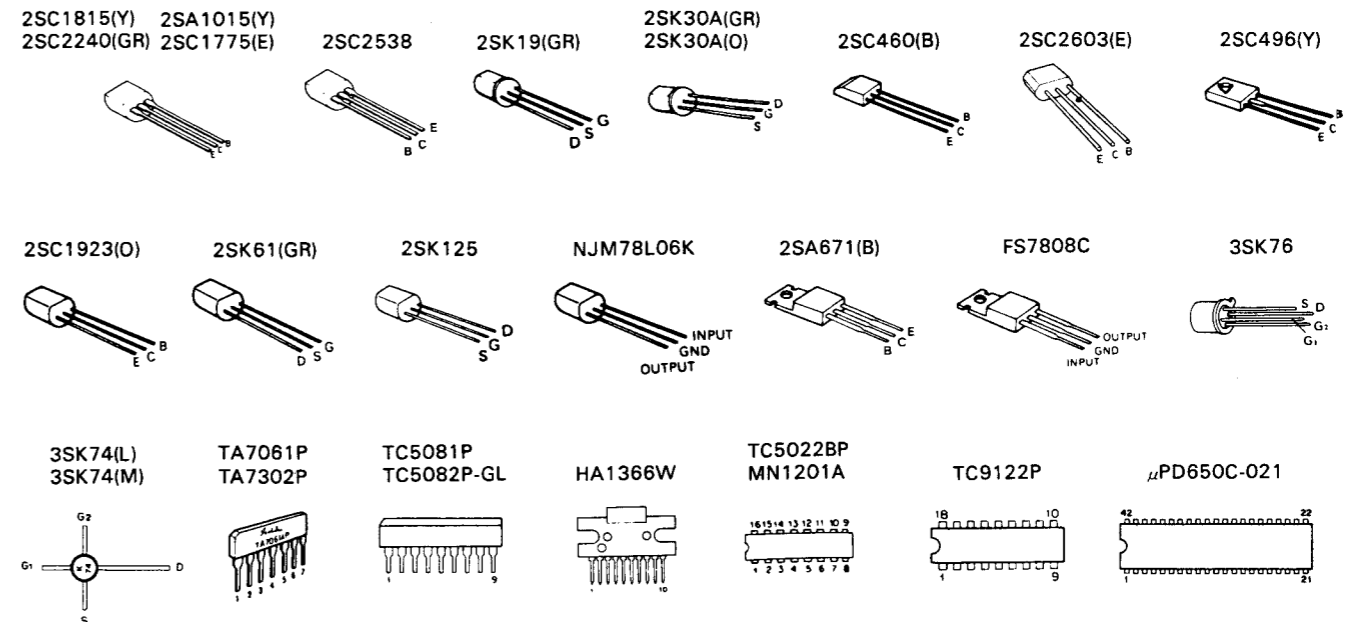
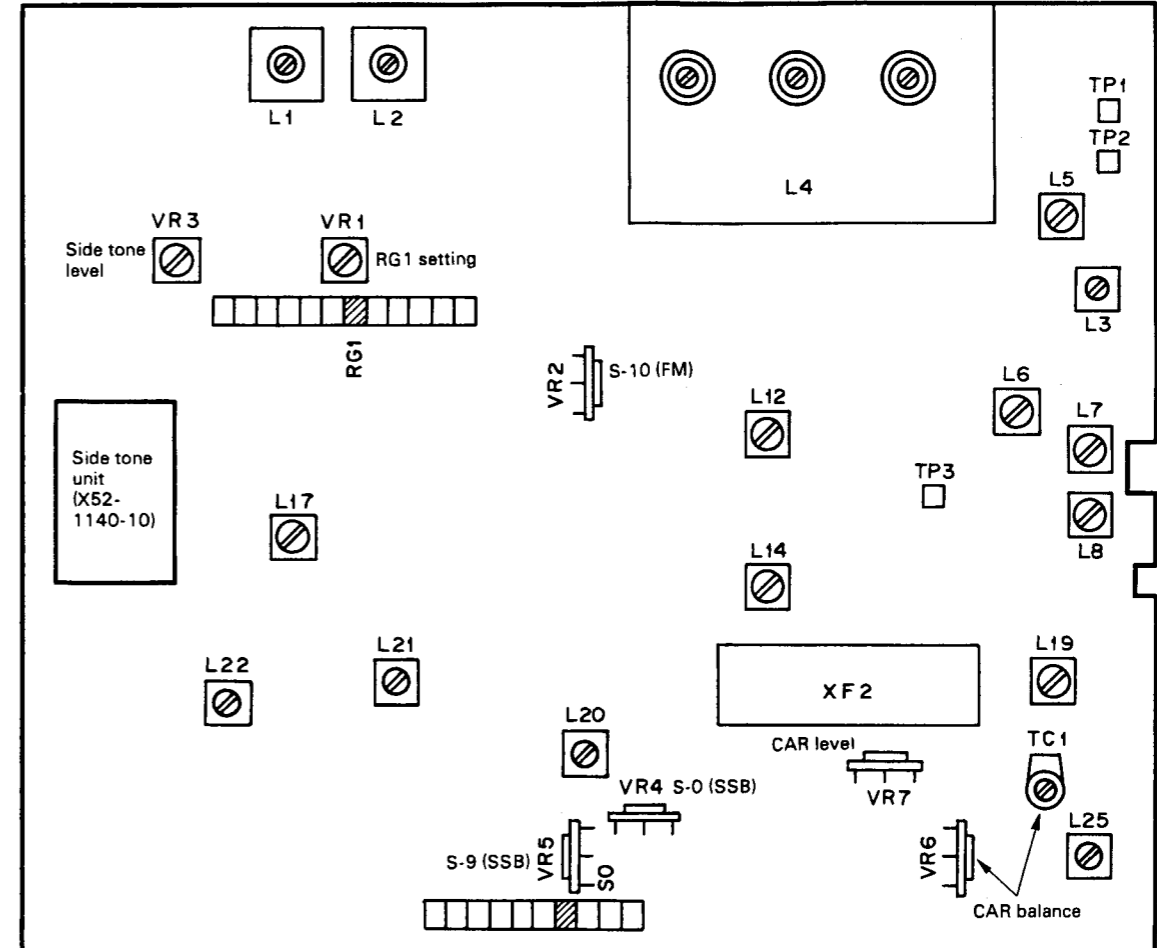

WIRE HARNESS (K) TYPE

Symbol color
BLU Blue GRY Gray WHT White
BRN Brown ORA Orange YLW Yellow
GRN Green VLT Violet

Table with columns: Connector No., Terminal No., Destination Connector, Terminal, Color, Remarks, and multiple rows of wiring data.

WIRE HARNESS (K) TYPE

Table with columns: Connector No., Terminal No., Destination Connector, Terminal, Color, Remarks, and multiple rows of wiring data.

Table with columns: Connector No., PC Bound/Parts, listing various components like FINAL UNIT, RX UNIT, CONTROL UNIT, etc.

< Wireharness Parts >

Table with columns: Parts No., Parts, listing components like Mini connect wafer, Mini connect pin, Mini connect housing, etc.