



## 'Phoenix' Crystal Set Mk2

Back in the 1920's the first radios that the general public had access to were simple unpowered receivers. With only one or two receivable stations selectivity was not really a problem. Over the years many designs have been used some simple and easy to reproduce and others complicated but offering higher performance levels.

For many these radios have lost favour as we use modern sensitive receivers that offer room filling volume with a wide choice of different stations that would be impossible to hear with the simplest crystal radio and its headphones.

Many people despite the short comings of these early radios still enjoy building and using crystal radios, it's a magical feeling listening to a radio that never needs batteries and just pulls its power directly from the signal in the sky.

The Crystal radio kit here winds back time to give you the experience that early radio pioneers felt but uses modern quality parts that give good levels of performance more suited to todays crowded medium wave band.

The kit here is complete with a 'Vintage' looking enclosure and front panel in the style of radios by companies such as heathkit, this style was typical for radios of the 1950's but the technology used was still 1920's!

Typical Crystal Radio Circuit from the 20's

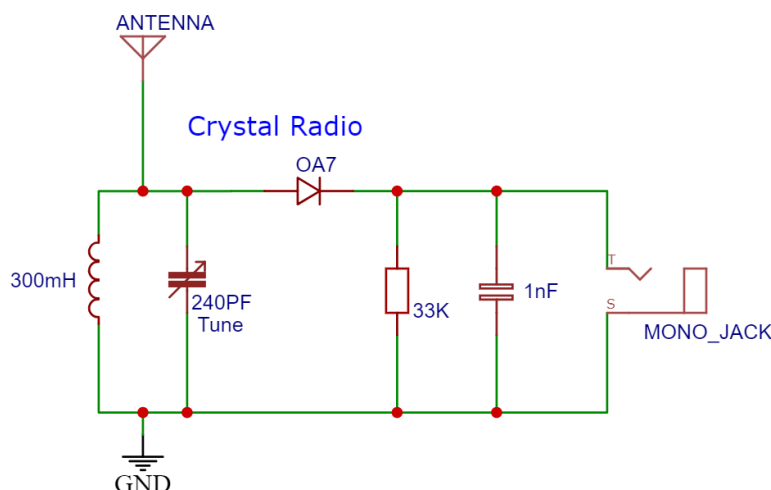

This was a popular circuit that still is used today in many Crystal radio Kits, it does have some problems. With the antenna connected directly to the top of the coil the selectivity is low and the set may only pick up one or two stations, often the same stations can be heard at all points of the tuning control at the same time. This circuit

was fine in the early days of radio when there was only one local station to hear anyway.

With good quality parts the circuit here is still usable today despite its short comings.

This design was improved upon by 'tapping' the coil so that the diode could be connected at some point further down the coil than the top, the purpose of doing this was to reduce



# KANGA PRODUCTS

Electronic Kits For The Radio Amateur

the loading that the detector put on to the coil, this improved the selectivity and made the radio much more suitable for use on the now busy MW band . The problem with adding taps is that it makes the coil more difficult to build and often a number of taps are needed to find the best match.

The circuit we have used allows the use of a simple coil. Rather than tap the coil to reduce the load from the detector we are using a small low value capacitor to connect the detector, this allows good signal transfer from the coil but still gives higher selectivity, a winner on both accounts.

The next important part of the circuit is the diode, not any diode can be used for this, most modern day diodes are silicon and have a relatively high forward volt drop (typically 0.7 volt) that means the signal would need to be really strong just to get the diode to conduct and so the radio would be very insensitive, to the point I doubt if you would hear anything at all. A better choice is the germanium diode, these diodes have a forward volt drop of less than half of a silicon diode and so much weaker signals will be heard. The selectivity and sensitivity of this circuit is very good but is still low cost and easy to build.

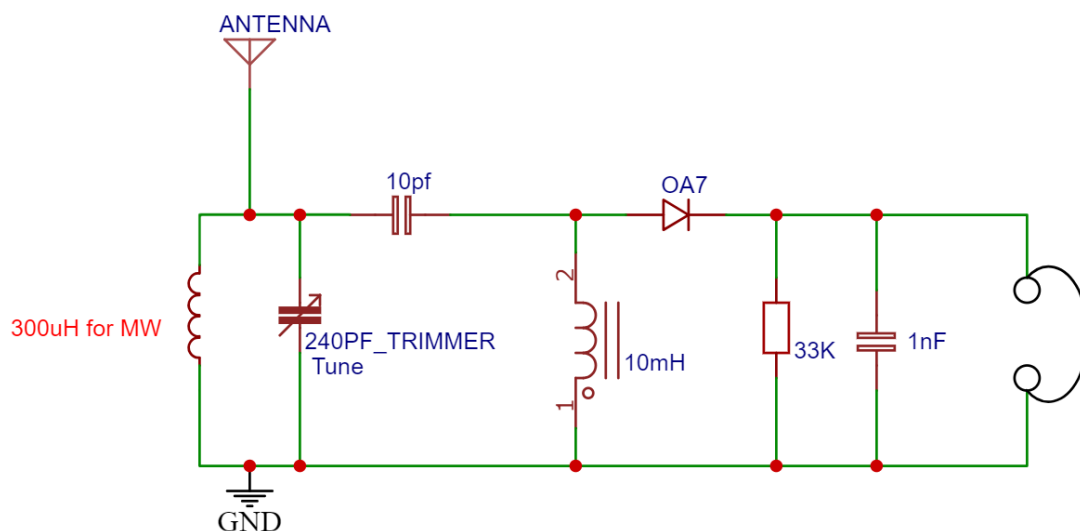

We have now altered the circuit more to allow the antenna to be inductively coupled to the tuning coil to improve the performance from the circuit above. A small two switch will let you change from 'S' for a short antenna, no earth, direct connection to the tuned circuit, or 'L' for long wire with a earth fed to the coupling coil.

To make the circuit easier to build we have supplied a small printed circuit board that the parts fit onto.

Please read **ALL** the instructions **BEFORE** you build it!



# KANGA PRODUCTS

Electronic Kits For The Radio Amateur

Let's check the parts that come with the kit.

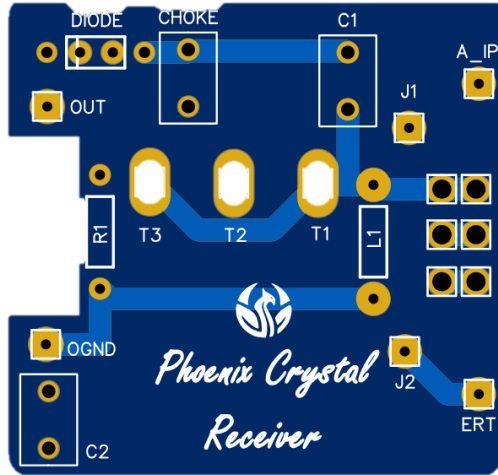

1 x PCB (this is the main part of the radio kit)

L1 Antenna Coil (See Instructions)

1N34 Point Contact Diode (or equivalent)

Choke 10mH

C1 10pF Disk

C2 1nF (Green)

Antenna type Switch

R1 33K or 36K  $\frac{1}{4}$  watt Resistor

4 x Sockets

1 x Front Panel

1 x Case

1 x Tuning Knob

Foam Tape

Mounting screw set

Headphone Socket

Socket wires

## Important note.

Remember this radio gets all its power from the radio signal and so it's important to give it a good antenna and earth so it can catch as much signal as it can.

The output is designed for use with high impedance headphones for best results, the next in choice would be the Crystal earphone, these are troublesome at best and often stop working, but they are easy to get going again, just needing a flick or a tap on the desk to get them going. At a push I have used standard earbuds or headphones if the signals are very strong, but if you have to do this try and use sensitive headphones for the best volume and do remember that these are not the right type of phones for a crystal set and so result may vary depending on how strong the signals are and the quality of the headphones, I have some rather expensive communications headphones that seem to work ok on strong signals but high impedance phones are much better.

If you do try standard modern headphones wire the two elements of the headphones in series with each other for best results (That's the way the instructions show you to wire the kits headphone socket). Please give it ago and let me know if it works for you, I have a reasonable antenna, a 60ft endfed long wire up at about 25-30ft and I get reasonable volume and selectivity from a number of stations using normal headphones with such an antenna and earth.



# KANGA PRODUCTS

Electronic Kits For The Radio Amateur

Lets Build the radio

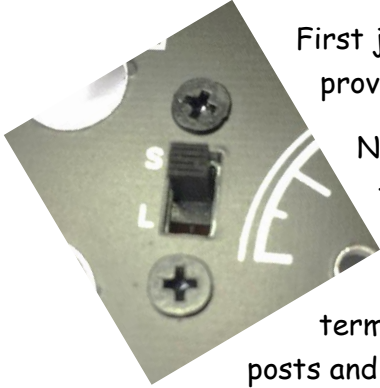

First job is to fit the small switch. Use the two small black screws provide to secure it as shown here.

Next Looking at the front panel you can see that there are four holes for the terminal posts. Fit the posts and use a

spanner/pliers to tighten the posts to the front panel, I use a thin screwdriver in the hole in the posts to stop the post from rotating while you do this, don't go mad. It's not a test of strength!



Next let's move to the PCB

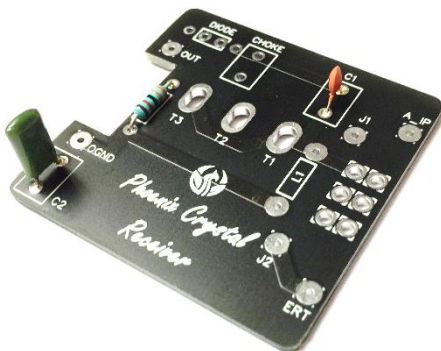

The PCB is designed to make building the crystal radio very easy and trouble free. Larger wide spaced pad have been used so it's suitable for beginners to build (With care!).

Let's start by fitting the two capacitors C1 and C2. Their positions are on the silk screening on the board.

Next lets fit the resistor, its value is not very critical and any value around 30-40K will be fine. I tend to use either 33 or 36K ohms in my radios. You will be supplied with a resistor in that range for R1,



# KANGA PRODUCTS

Electronic Kits For The Radio Amateur

Next fit the supplied 10mH choke, fold it over when you fit it as shown here, (this stops it touching the bottom of the case later.

Now fit the last part the diode, the diode supplied is a Germanium point contact diode. Do not try and use a silicon signal diode like the 1N4148 if you lose or break it as although they look the same, they will not work.

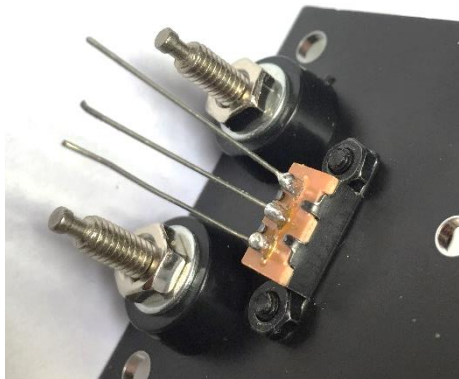
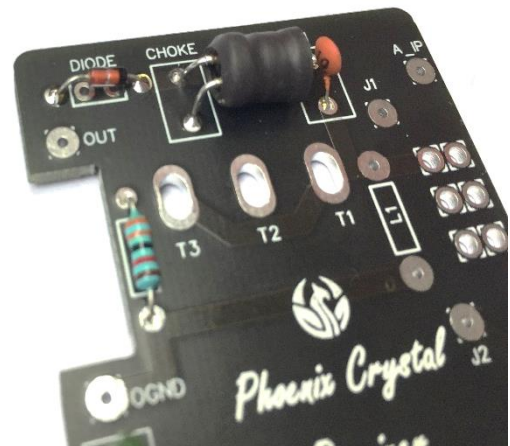

Now back to the front plate, using the off cuts from the other parts already fitted solder 3 straight leads to the contacts on the switch as shown here.

Now we need to prepare the variable capacitor.

We need to fit the shaft extender, Find the 10mm black plastic extender and the 12mm x m2.5 screw. Now hold the two flat sections on the brass short shaft and tighten the screw. This way you do not risk damage to the capacitor due to excessive force while doing this job.

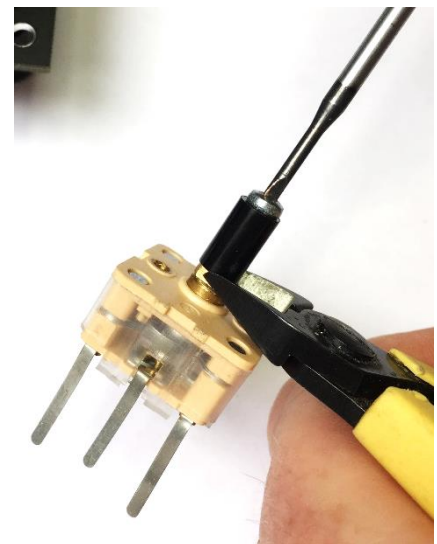

On the back of the capacitor you will see two adjustable trimmers set these to be fully open. Make sure you fit it the way shown here, you will be provided with two short flat head steel screws to fit the capacitor to the front panel.

We are going to start putting things together now but before we do I suggest attaching two lengths of foam tape as shown in the picture below, you can fit them later but I think you will find it easier to fit it BEFORE you attach the PCB to the front plate.

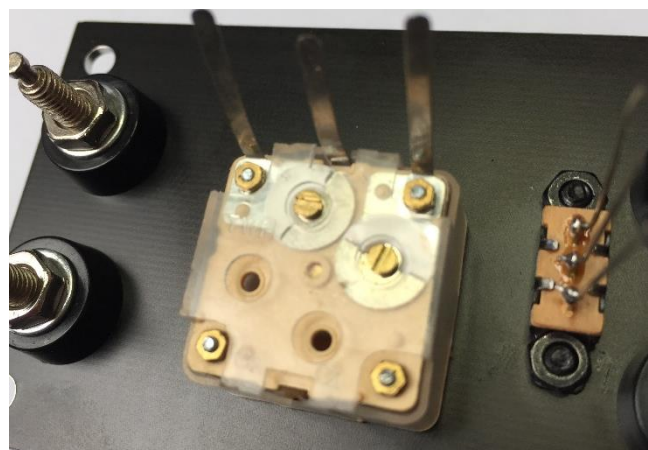



# KANGA PRODUCTS

Electronic Kits For The Radio Amateur



These foam strips help hold the coil in place later.

Ok now we can fit the PCB to the front panel.

The 3 legs of the capacitor must go through the board as in this photo and so must the 3 wires from the switch, the switch wires can go through either set of the two rows of holes, which ever works out best for you.



Solder and trim the wires.

Not much work to do now, but care is going to be needed now. The coil uses very thin wires so we must not snap these. Position the coil now so the end with 3 wires is nearest to the side with the small switch.





# KANGA PRODUCTS

Electronic Kits For The Radio Amateur

Notice that the coil has 2 wires that are white (ish) and 2 wires that are black.

The white wires are one pair and the black another.

Carefully push the coil in place as shown

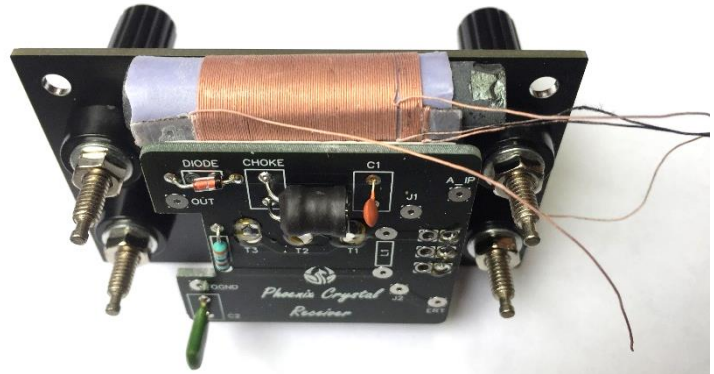

We now will connect the coil to the PCB.



The two white wires need to be trimmed and soldered to the position marked 'L1' on the board, these wires have a very thin insulation on them that will burn off when you solder them in place.

These wires are the main tuning coil for the radio. The other pair of Black wires are an aerial coupling coil.

We will now wire these two black wires to the J1 and J2 pads.



In the picture above it can be hard to see these black wires so I have shown the positions that they must be soldered to.



# KANGA PRODUCTS

Electronic Kits For The Radio Amateur

Now we need to make the connections to the 4 terminal posts. Use the resistor/Choke or diode lead offcuts for this. If you're looking at a paper copy of the instructions again these maybe hard to see, why not look on our website and read the full colour instructions there. ([Kanga-products.co.uk](http://Kanga-products.co.uk))

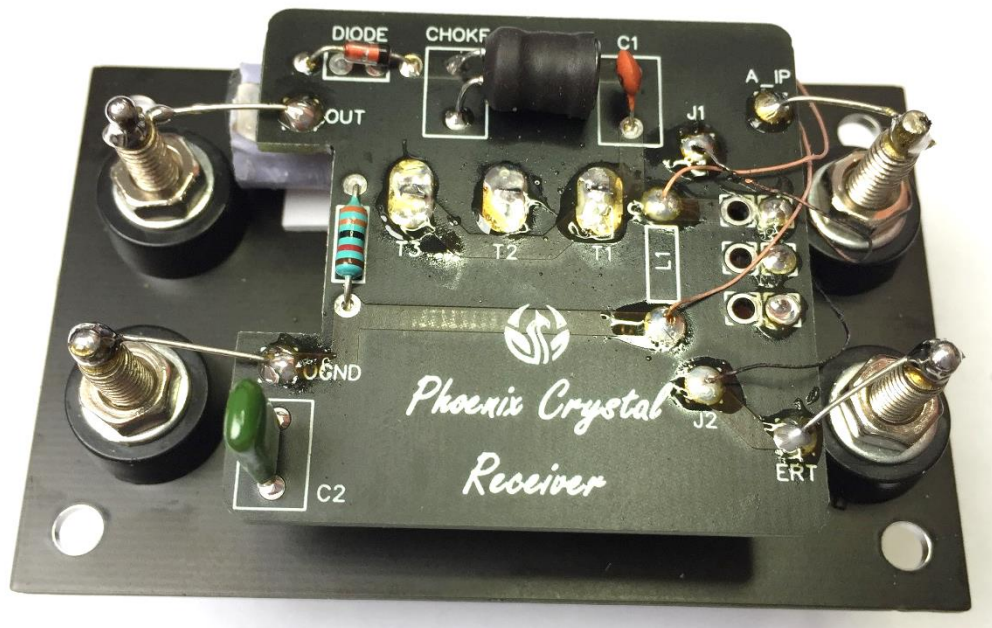

Next we can prepare the headphone socket.

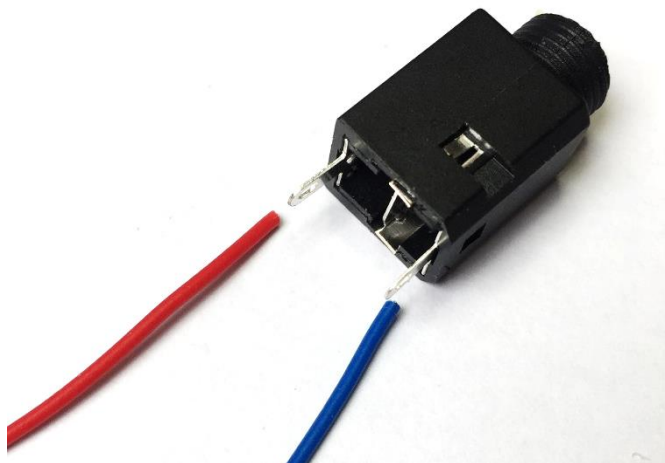

There are two lengths of coloured wire in the kit, the colour doesn't make any difference so don't worry if your wires are not the same colour as the ones here.

Strip and tin the one end of each wire and solder them to the two lugs on the headphone socket.

You will also have a small amount of heat shrink that you can use to

cover the soldering if you wish.

I now twist the two wires together just to make a neat job of it.





# KANGA PRODUCTS

Electronic Kits For The Radio Amateur

Now fit the socket to the side of the case as shown here. Then attach the wires to the output terminal posts.

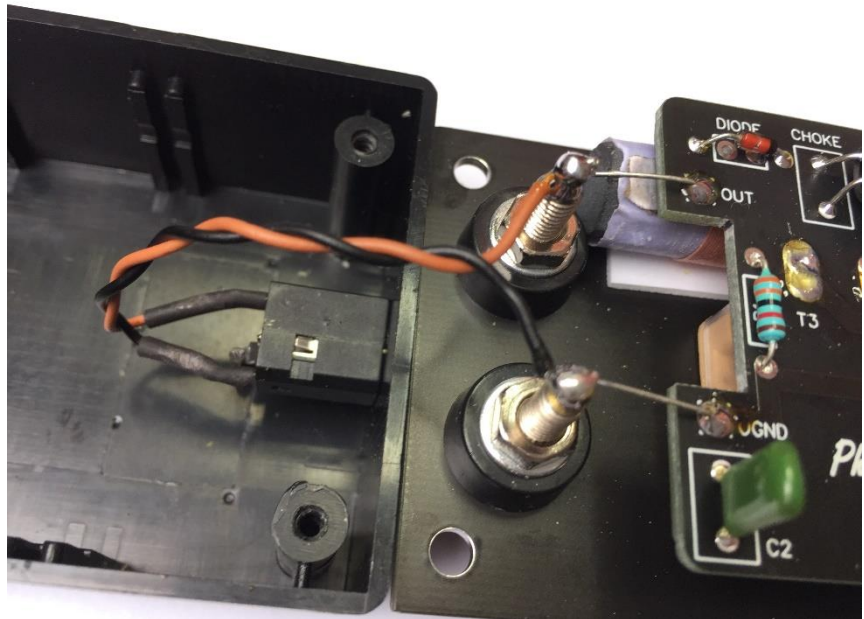

We are nearly done now.

Now drop the front assembly onto the box and secure with the four black screws supplied.



Fit the tuning knob. I just tighten the knob a little at first, just so it grips very slightly, then turn the tuning control and set it so it points correctly. Once you have it set correctly set the control to point upwards and then you can get easy access to the fixing screw, tight then screw to secure the knob.

The finished radio should look like this. (yours will also have a switch)

Turn over the radio and fit the four small stick on feet.

We done you have completed the radio. This is not the end, now the fun begins.....





# KANGA PRODUCTS

Electronic Kits For The Radio Amateur

Connect your headphones /earphone to the two terminal posts labels 'PHONES' or plug them into the socket on the side. Connect your antenna and earth wires.

The switch on the front is labelled S and L, more on that below.

Right the BIG topic, many books have been written on this subject, it's a bit of a black art.

## **Antennas,**

Most books I have read tell you that for a crystal radio to work you need to provide it with a very good antenna and earth. I can understand why. The 'Power' to the radio is just from the amount of signal that the antenna (and earth) can feed to the radio, the more signal the louder the volume. Books tell you to get a 50 to 100ft wire up in the sky as high as you can. Drive copper rods into the ground to act as an earth connection. Books say it's not going to be worthwhile without these. Well that would be great if you can do that but I do understand that this can be difficult to do. Back in the 30's when crystal sets offered the only form of 'radio' entertainment people accepted this as normal but now with our modern portable radios, digital TV etc you may be tempted to expect some performance without such this but despite us living in 2020's, we are using technology from a 100 years ago here and the rules haven't changed. The better the antenna and earth the better your signals will be with the set, you can try connecting a wire to a metal water pipe (Central heating pipes can be a good way to go) for the earth and a 30ft plus (Longer is better) wire as high as you can for the antenna will provide reasonable signals for this set.

It's as I said antennas can be bit of a black art, and something that you can play with for hours/days to try and find the best arrangement for you and your location.

## **Why the switch?**

Ok if you have a good long wire antenna and a good earth great, put the switch to the 'L' (Long) position and you will have better selectivity when you tune the radio. If like many of us you want to try the radio with a random short length of wire and no earth at all try the switch in the 'S' (short) position. This will allow the radio to work with much shorter wires and no earth but the performance may not be so good. Try the switch both ways with either antenna, you're not going to break anything!

I hope you enjoyed building the crystal radio and that you enjoy using a bit of 1920's technology.

The crystal radio will never compare to the modern receiver but it will work as long as there are radio signals still in the air and never need a battery.



# KANGA PRODUCTS

Electronic Kits For The Radio Amateur

## Possible modifications

- i) The one problem I always find with crystal sets today is the earphone itself. All Crystal earphones have a common problem. Due to such low demand worldwide for them only one factory builds them, unfortunately they are not well built. They suffer from a problem of either sticking or just randomly stop working, it's an easy fix, just a tap on the desk will get them going again. Against all the rules of crystal sets, try standard headphones, the type that come with mobile phones. Due to the unusual circuit of this crystal set I find with a strong signal level they work!
- ii) Try anything (that's not connected to power cables !!! (be safe!) ) metallic as an antenna, I know people have used the old fashion metal beds in the past, You may even find connecting to the metal water pipe of a radiator will work with the radio switch set to 'S'
- iii) Fed up with listening to MW? I have swapped out the coil connections (marked L1) and put a 4.7mH inductor (the small cheap ones that look like a resistor) in its place, I can now listen to Radio 4 Longwave at decent volume.

We Wish you Good Reception and have fun

73 Paul MOBMAN