

RigExpert® Fobos SDR

Wideband general purpose Software Defined Radio receiver

Applications

- SIGINT/COMINT
- Spectrum survey
- Wideband waveform digitizing
- HAM radio (HF + VHF/UHF)
- Test and measurement
- Wireless, Cellular, IoT, Media streaming
- Radio astronomy
- High Performance VHF/UHF Telemetry

Main Features

- Double frequency conversion heterodyne
- Two HF direct sampling channels
- Fully continuous Rx data stream
- 14 bit ADC
- USB 3.0 interface

Features

- Primary receiving signal path with double frequency conversion heterodyne UHF/VHF with switchable preselector and intermediate frequency filters
- Auxiliary two coherent direct sampling Rx channels for HF band
- Precise 14 bit analog to digital conversion
- 8-50 MHz IQ sample rate
- Fully continuous IQ data stream
- RF SMA connectors
- Cypress CYUSB3014-BZXC USB 3.0 interface controller
- Robust USB3.0 TYPE B socket
- Clock-in and clock-out options



1

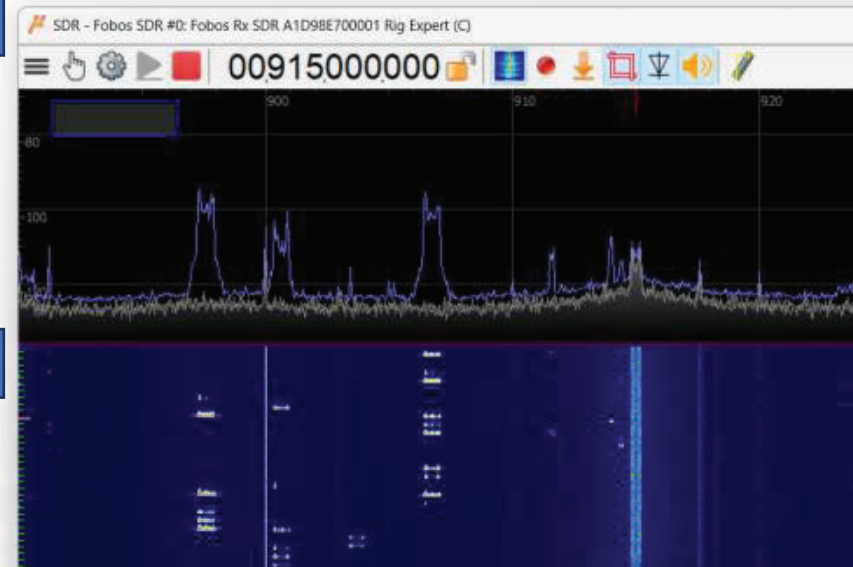

- 8 lines of user defined low speed general purpose digital output
- Compact PCB design, no ponderous parts
- No switching power regulators, no onboard noise supplies
- Low power consumption, no auxiliary external power supply needed, no cooling facility needed
- EMI Shielded RF part
- Power switch option, no unplug/replug needed
- Lightweight API library for Windows and Linux
- SDRSharp, SDR++, SoapySDR, GNURadio, HDSDR ExtIO, uSDR software support

Block Diagram

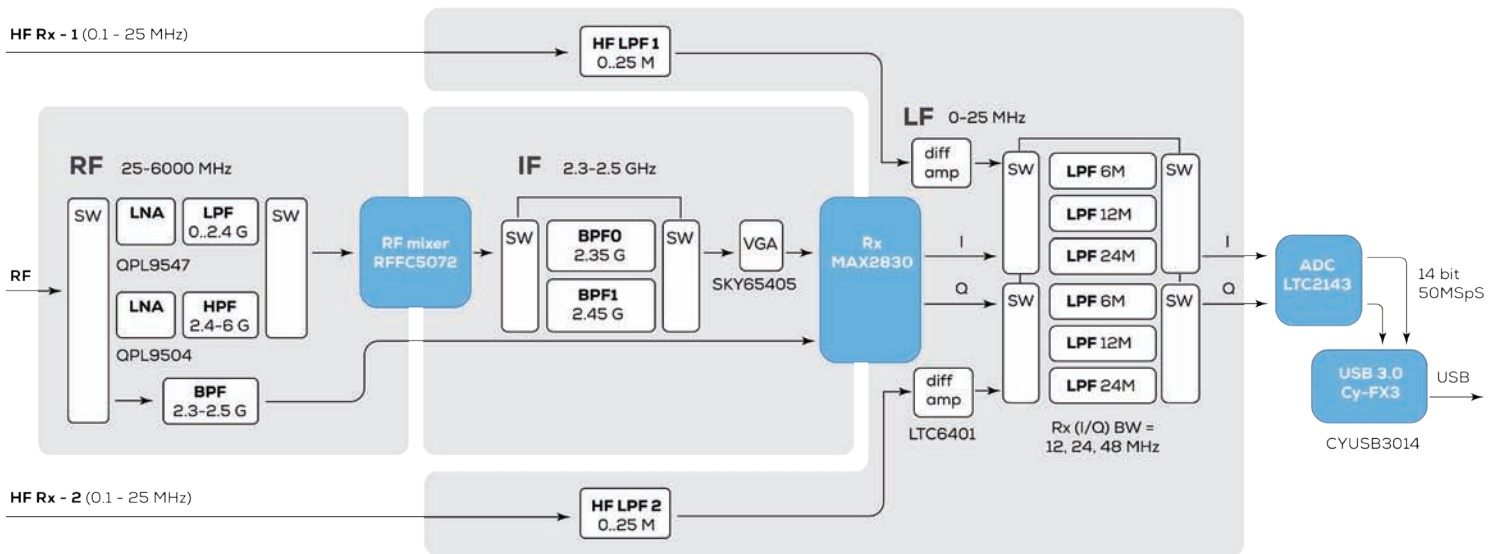

Specifications

Frequency range:	RF input: 50-6000 MHz tuning range, 25-6025 MHz coverage HF inputs: no tuning, 0.1 - 25 MHz coverage
Operation modes	primary: double conversion heterodyne for VHF/UHF range (RF input) auxiliary: two-channel direct sampling for HF range (HF inputs)
IQ sample rate (bandwidth):	8 - 50 MHz
ADC resolution:	14 bits
Frequency stability:	±0.5 ppm
Blocking Dynamic Range	82 dB UHF/VHF 86 dB in HF
Selectivity	-110 dBm combined selectivity
IQ Image rejection	52 dB (software)
Maximum RF input	+10 dBm
Power source	USB Plug, 3.8 - 5.5 V nominal
Current consumption	450 mA in idle state 670 mA in direct sampling mode 850 mA in full band operating mode
Clock source	- internal - external, selectable within API
External clock input	10 MHz, high impedance
Clock output	10 MHz, 50ohm, 3.0 V p2p, permanent
Operating Temperature	0..+60° C
PCB type	6-layer impedance controlled, HASL finished
PCB dimensions:	110 mm x 60 mm
Outline dimensions	130 mm x 60 mm x 16 mm
Weight	143 g

Connectivity

- USB 3.0 Type-B plug for power, control and data streaming
- Power control jumper
- 1x RF Input, RF primary Rx path, 25 MHz – 6 GHz (SMA female)
- 2x RF Input, (HF1, HF2) auxiliary Rx path, 100 kHz – 25 MHz (SMA female)
- 1x Clock input (SMA female)
- 1x Clock output (SMA female)

Software

- libusb/WinUSB driver for Windows
- Native libusb support for Linux
- Lightweight open source multi-platform API library for Windows and Linux
- Easy to compile and run, no external dependencies, no heavy libraries and service packs needed
- Application examples for basic user cases: setup and tuning, IQ data acquisition, TCP streaming, recording
- SDRSharp plugin C# implementation source code examples and binaries
- ExtIO plugin interface C/C++ implementation source code examples and binaries
- Compatibility plugins for state of art software SDRSharp, SDR++, SoapySDR, GNURadio, HDSDR ExtIO provided
- Native supported by μ SDR software v.1.7 and later, see <https://sourceforge.net/projects/u-sdr/>
- For latest software releases (drivers, API library and demos) visit <https://rigexpert.com> web site