

## CIRCUIT DESCRIPTION

### GENERAL INFORMATION

UB305Z

#### 1. Tuning Range (MHz)

25.0000	-	27.9950
28.0000	-	53.9950
54.0000	-	71.9950
72.0000	-	75.9950
76.0000	-	87.9950
88.0000	-	107.9950
108.0000	-	136.9950
137.0000	-	173.9950
174.0000	-	215.9950
216.0000	-	224.9950
225.0000	-	399.9950
400.0000	-	512.0000
806.0000	-	823.9875
849.0125	-	868.9875
894.0125	-	956.0000
1240.0000	-	1300.0000

#### 2. Frequency Range of the Local Oscillators

##### 1st Local Oscillation Frequencies:

405.7 MHz	-	596.6 MHz
555.0 MHz	-	755.9 MHz
859.3 MHz	-	919.3 MHz

##### 2nd Local Oscillation Frequency:

254.6500 MHz	-	254.7000 MHz
288.9050 MHz	-	289.0000 MHz
335.6050 MHz	-	335.7950 MHz
369.9500 MHz	-	370.0000 MHz

3rd Local Oscillation Frequency:

44.5500 MHz

### 3. Intermediate Frequencies

1st IF:

25.0000	-	310.9950 MHz	IF: 380.6050	-	380.7000 MHz
311.0000	-	512.0000 MHz	IF: 243.9050	-	244.0000 MHz
806.0000	-	1300.0000 MHz	IF: 380.7000	-	380.7950 MHz

2nd IF:

WFM Mode	IF: 10.7000 MHz
FM/NFM/AM Mode	IF: 45.0000 MHz

3rd IF:

FM/AM Mode	IF: 450 kHz (BW: ±10kHz)
NFM Mode	IF: 450 kHz (BW: ±6kHz)

## CIRCUIT DESCRIPTION

### 1. ANT. Filter and RF Amp. Stage

Incoming RF signal is selected by specified filter (VLO~1300). Filtered signal is amplified by wide band amplifier, Q4 and Q5.

### 2. First Mixer and PLL Circuit Stage

Amplified RF signal is converted into the first IF signal at the first Mixer stage (First IF : Around 380.7MHz or 244.0MHz). This first local oscillator signal(vco1,vco2 or vco3) is delivered from PLL synthesizer(IC10).

The VCO frequency(vco1,vco2 or vco3) is divided by a programmable

counter which is preset from memory and compared to reference frequency. Any frequency or phase difference produces a correction signal to change the VCO tuning voltage. This tuning voltage then forces the VCO to oscillate at the frequency required for the counter to produce a output that is in phase with change the frequency. Thus, changing the modules of the counter will change the frequency of the VCO.

### 3. Second Mixer and WFM demodulator Stage

The first IF signal of each tuning range is mixed down with either the second local oscillator(vco4 or vco5) around 254.7MHz, 289.0MHz, 335.7MHz or 370.0MHz to obtain the common second IF signal of 45.0MHz or 10.7MHz. Second local signal(vco4 or vco5) is delivered from a PLL synthesizer(IC10). The second IF signal of 10.7MHz is delivered to WFM demodulated IC (IC1). The demodulated audio signal is delivered to audio AMP.(IC5)

### 4. Third Mixer and FM/NFM/AM demodulator Stage

The second IF signal of 45.0MHz is converted to the third IF signal of 450kHz at the inside of FM detector IC.(IC6). Also AM signal that divided from third IF signal is delivered to AM demodulated IC (IC8). The demodulated audio signal is delivered to audio AMP.(IC5)

The frequency program is entered from a decimal keyboard into a microprocessor(IC18) where it is multiplexed to driver the LCD display and decoded to enter the proper binary code in memory to control the PLL synthesizer.

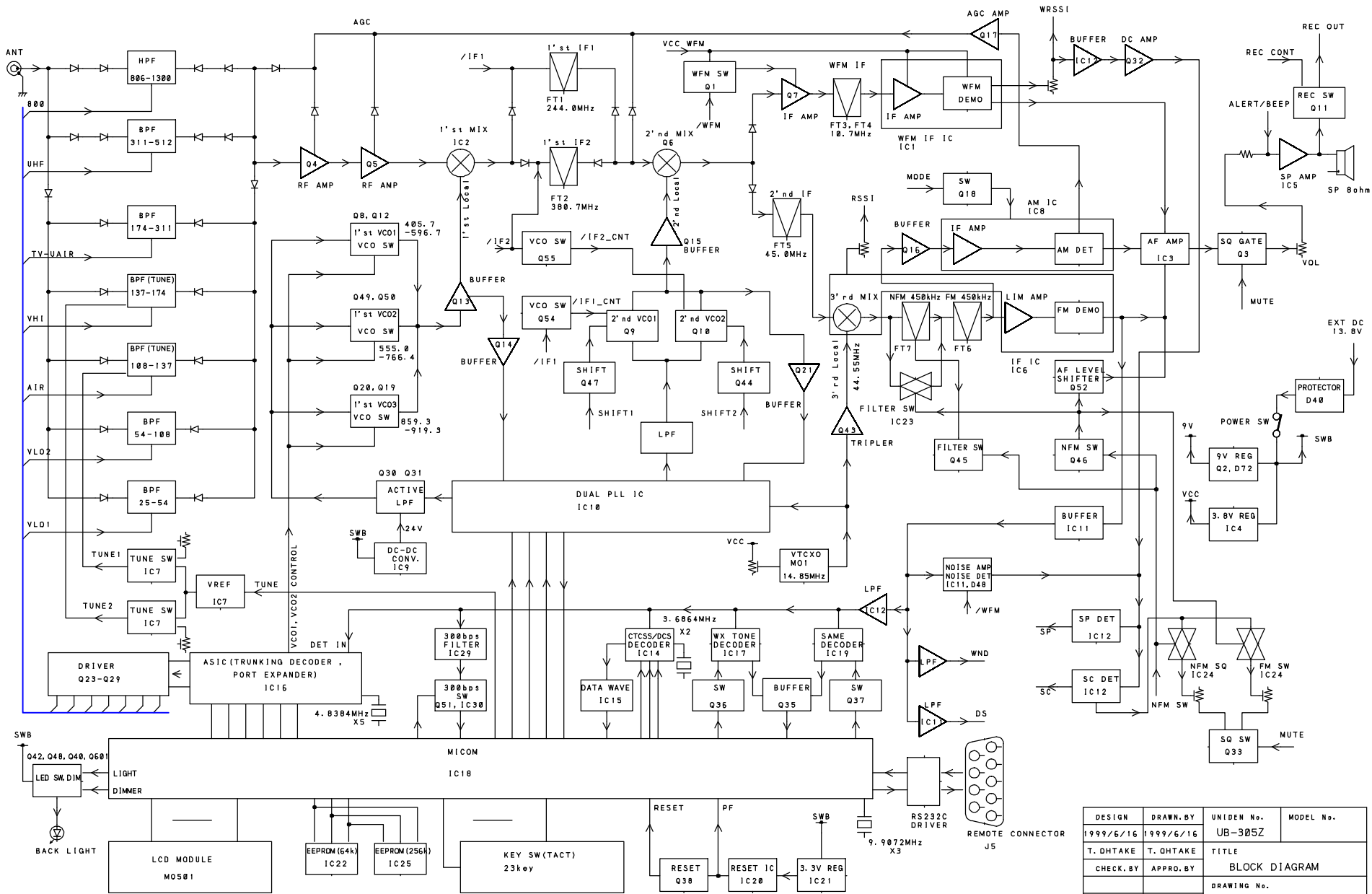

DESIGN	DRAWN BY	UNIDEN No.	MODEL No.
1999/6/16	1999/6/16	UB-305Z	
T. DHTAKE	T. OHTAKE	TITLE	
		BLOCK DIAGRAM	
CHECK BY		APPRO. BY	
		DRAWING No.	
REV. No		UNIDEN CORP.	

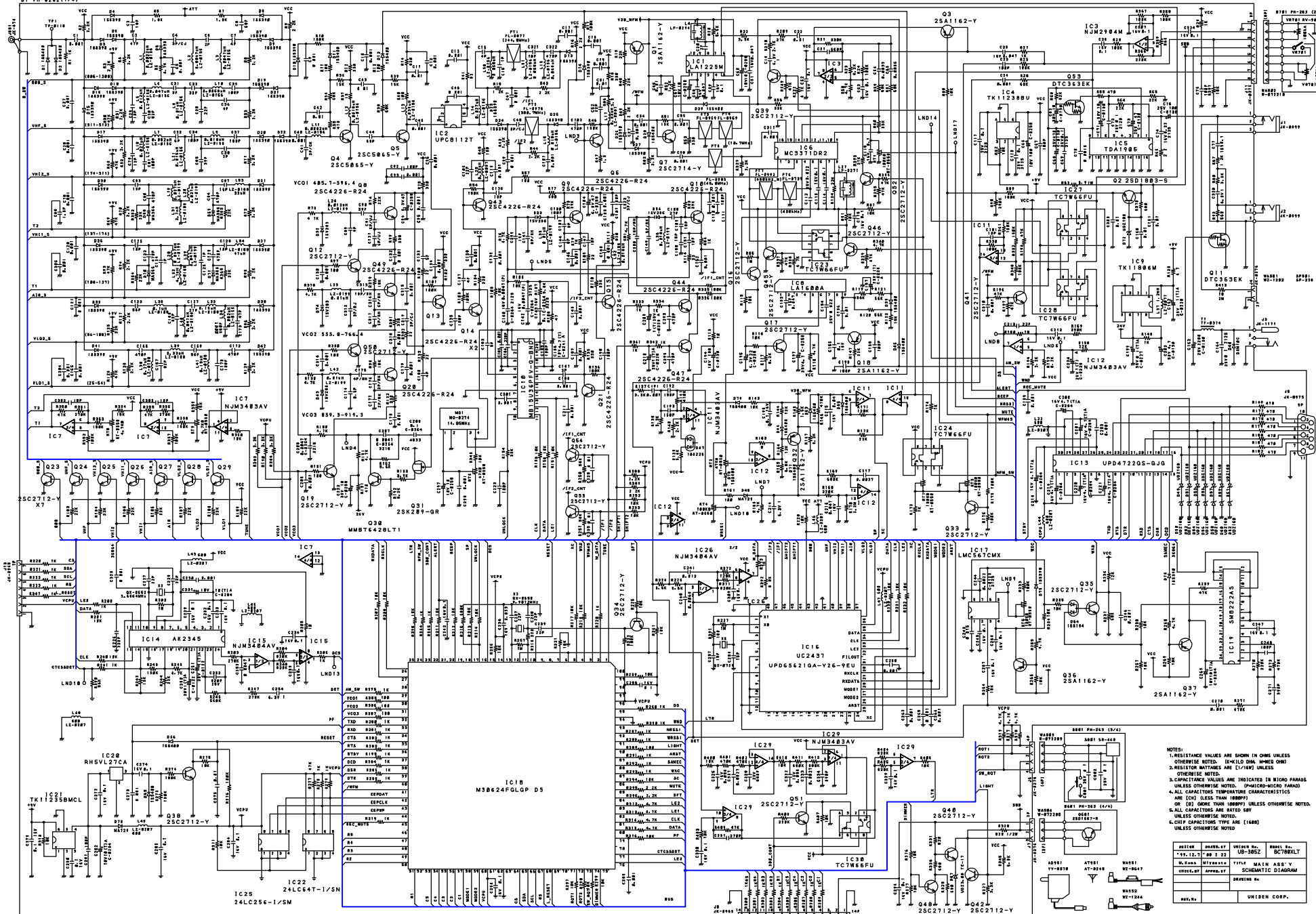

NOTES:  
 1. RESISTANCE VALUES ARE SHOWN IN OHMS UNLESS OTHERWISE NOTED. (E=100 OHMS, M=1000 OHMS)  
 2. RESISTOR INTERTYPES ARE (E=100 OHMS) UNLESS OTHERWISE NOTED.  
 3. CAPACITANCE VALUES ARE INDICATED IN MICRO FARADS UNLESS OTHERWISE NOTED. (P=PICTO-FARAD)  
 4. ALL CAPACITORS TEMPERATURE CHARACTERISTICS ARE (C=1) UNLESS THAN (J=50PPM) OR (E) (MORE THAN 100PPM) UNLESS OTHERWISE NOTED.  
 5. ALL CAPACITORS ARE RATED 50V UNLESS OTHERWISE NOTED.  
 6. CHIP CAPACITORS TYPE ARE (1488) UNLESS OTHERWISE NOTED.

DESIGN	DESIGNED BY	DESIGNED NO.	REVISED BY
81-123	PH-22	18-1862	ICT/VALT
W. S. HARRIS	INTERVAL	TYPE	MAIN ASSY
CHECKED BY	APPROVAL	DATE	SCHEMATIC DIAGRAM
REVISED	DESIGNED BY		
REV. NO.	WRITTEN CORP.		

WA502  
W-072210

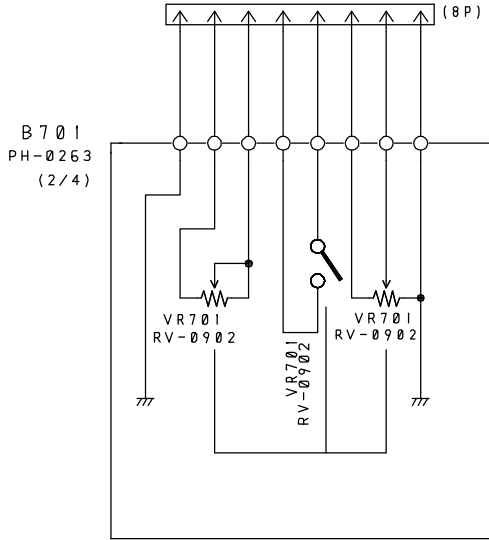

WA503  
W-072209

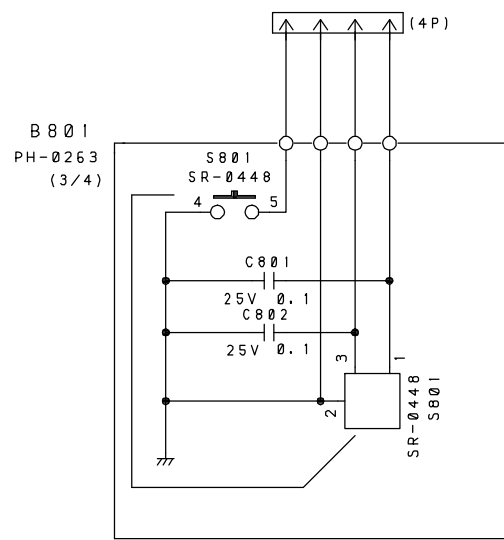

WA504  
W-072208

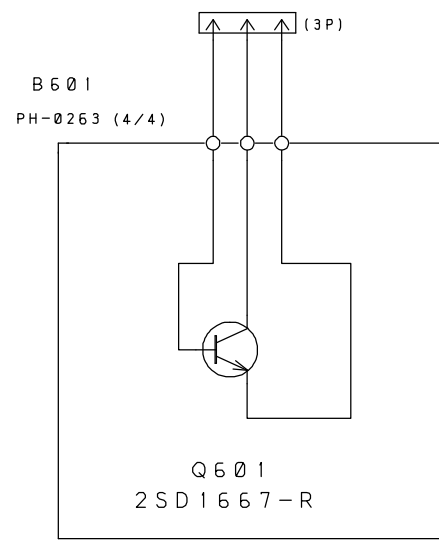

DESIGN	DRAWN BY	UNIDEN No.	MODEL No.
	Feb, 10, 2000	UB-305Z	BC780XLT
	Miyamoto	TITLE	
CHECK BY	APPRO BY	SCHEMATIC DIAGRAM	
		DRAWING No.	
REV. No		UNIDEN CORP.	

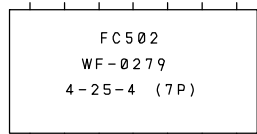
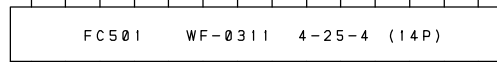
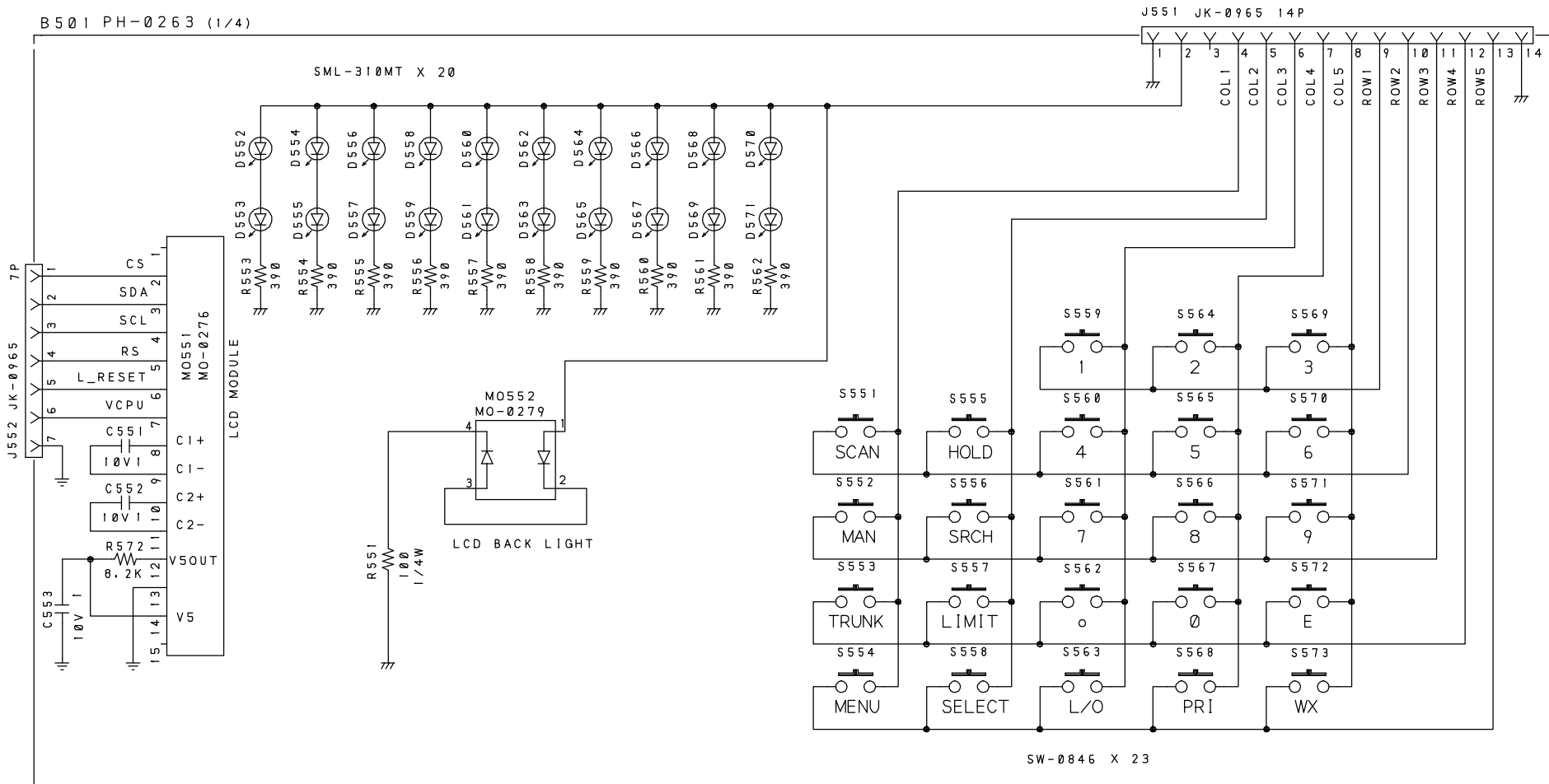

NOTES :

1. RESISTANCE VALUES ARE SHOWN IN OHMS UNLESS OTHERWISE NOTED. (K=KILO OHM, M=MEG OHM)
2. RESISTOR WATTAGES ARE [1/10W] UNLESS OTHERWISE NOTED.
3. CAPACITANCE VALUES ARE INDICATED IN MICRO FARADS UNLESS OTHERWISE NOTED. (P=MICRO-MICRO FARAD)
4. ALL CAPACITORS TEMPERATURE CHARACTERISTICS ARE [CH] (LESS THAN 1000PF) OR [B] (MORE THAN 1000PF) UNLESS OTHERWISE NOTED.
5. CHIP CAPACITORS TYPE ARE [2125] 50V UNLESS OTHERWISE NOTED.

DESIGN	DRAWN BY	UNIDEN No.	MODEL No.
'99.11.12	'99.11.12	UB-305Z	BC780XLT
Miyamoto	M. Koma	TITLE KEY PCB	
CHECK BY	APPRO BY	SCHEMATIC DIAGRAM	
		DRAWING No.	
REV.No		UNIDEN CORP.	