

101.11:  
-2646 A

# TM 11-2646A

DEPARTMENT OF THE ARMY TECHNICAL MANUAL

UNIVERSITY OF VIRGINIA  
ALDERMAN LIBRARY

NOV 28 1990

GOVERNMENT DOCUMENTS

## CAPACITANCE- INDUCTANCE- RESISTANCE TEST SET AN/URM-90

This copy is a reprint which includes current pages from Changes 1 through 5.

UNIVERSITY OF VIRGINIA LIBRARY



X004881012

DEPARTMENT OF THE ARMY  APRIL 1956

CHANGE }  
No. 5 }

HEADQUARTERS  
DEPARTMENT OF THE ARMY  
WASHINGTON, D.C., 30 September 1975

## CAPACITANCE-INDUCTANCE-RESISTANCE TEST SET AN/URM-90

TM 11-2646A, 25 April 1956, is changed as follows:

Page 1. Paragraph 1.1 is superseded as follows:

### 1-1. Indexes of Publications

a. *DA Pam 310-4.* Refer to the latest issue of DA Pam 310-4 to determine whether there are new editions, changes, or additional publications pertaining to the equipment.

b. *DA Pam 310-7.* Refer to DA Pam 310-7 to determine whether there are modification work orders (MWO's) pertaining to the equipment.

Paragraph 2 is superseded as follows:

### 2. Forms and Records

a. *Reports of Maintenance and Unsatisfactory Equipment.* Maintenance forms, records, and reports which are to be used by maintenance personnel at all maintenance levels are listed in and prescribed by TM 38-750.

b. *Report of Packaging and Handling Deficiencies.* Fill out and forward DD Form 6 (Packaging Improvement Report) as prescribed in AR 700-58/NAVSUPINST 4030.29/AFR 71-13/MCO P4030.29A, and DSAR 4145.8.

c. *Discrepancy in Shipment Report (DISREP) (SF 361).* Fill out and forward Discrepancy in Shipment Report (DISREP) (SF 361) as prescribed in AR 55-38/NAVSUPINST 4610.33A/AFR 75-18/MCO P4610.19B, and DSAR 4500.15.

*Paragraphs 2.1, 2.2, and 2.3 are added after paragraph 2.*

#### 2.1. Reporting of Equipment Publication Improvements

The reporting of errors, omissions, and recommendations for improving this publication is authorized and encouraged. Reports should be submitted on DA Form 2028 (Recommended Changes to Publications and Blank Forms) direct to Commander, US Army Electronics Command, ATTN: AMSEL-MA-Q, Fort Monmouth, NJ 07703.

## 2.2. Administrative Storage

For procedures, forms and records, and inspections required during administrative storage of this equipment, refer to TM 740-90-1.

## 2.3. Destruction of Army Materiel

Demolition and destruction of electronic equipment will be under the direction of the commander and in accordance with TM 750-244-2.

*Page 48.* Paragraphs 51.1 and 51.2 are superseded as follows:

### 51.1. Cleaning

Inspect the exterior of the equipment. The exterior should be clean, and free of dust, dirt, grease and fungus.

- a. Remove dust and loose dirt with a clean lint-free cloth.

#### WARNING

The fumes of trichloroethane are toxic. Provide thorough ventilation whenever used. DO NOT use near an open flame. Trichloroethane is not flammable, but exposure of the fumes to an open flame converts the fumes to highly toxic, dangerous gases.

- b. Remove grease, fungus, and ground-in dirt from the cases; use a cloth dampened (not wet) with trichloroethane. After cleaning, wipe dry with a clean, lint-free cloth.
- c. Remove dust or dirt from plugs and jacks with a soft-bristled brush.

#### CAUTION

DO NOT press on the meter face (glass) when cleaning; the meter may become damaged.

- d. Clean the front panel, meters, and control knobs; use a soft clean lint-free cloth. If necessary, dampen the cloth with water; mild soap may be used for more effective cleaning. Wipe dry with a clean lint-free cloth.

### 51.2. Touchup Painting Instruction

- a. When the AN/URM-90 requires repainting, refinishing, or touchup painting, refer to Federal Standard No. 595a for a matching color. SB 11-573 lists painting tools and miscellaneous supplies required for painting.

- b. Refer to TB 746-10 for instructions on painting and preserving Electronics Command equipment. In touchup painting a perfect match with the exact shade of the original paint sur-

face may not be possible. There are many reasons for this, such as a change in the original pigment because of oxidation and differences as a result of manufacture. The prevention of corrosion and deterioration is the most important consideration in touchup painting; appearance is secondary. This, however, should not be construed to mean that appearance of the equipment is not important. Touchup paint should be accomplished neatly and in good workmanshiplike manner. Inspection personnel in the field should make allowances for slight color mismatch where minor touchup has been done, but not for neglect, poor workmanship, or in cases where the need for refinishing is obvious.

c. Remove rust and corrosion from metal surfaces by lightly sanding then with fine sandpaper. Brush two thin coats of paint on the bare metal to protect it from further corrosion.

*Page 94, paragraph 90d.* The last sentence is changed to read "Resistance must be  $66 \pm 1$  ohm."

*Page 99.* Paragraph 98.6 is superseded as follows:

#### **98.6. Q and D-Q Dial Calibration and Test**

To test the calibration of the Q and D-Q dials, perform the procedures in paragraphs 89, 90, and 91.

*Page 100, chapter 7.* The title is changed to read "SHIPMENT AND LIMITED STORAGE."

Section I title is deleted.

*Page 102.* Section II is deleted in its entirety.

Appendix is superseded as follows:

### **APPENDIX**

#### **REFERENCES**

The following publications are available to the maintenance man for the AN/URM-90:

DA Pam 310-4	Index of Technical Manuals, Technical Bulletins, Supply Manuals (types 7, 8, and 9), Supply Bulletins, and Lubrication Orders.
DA Pam 310-7 SB 11-573	Index of Modification Work Orders. Painting and Preservation Supplies Available for Field Use for Electronics Command Equipment.
TB 746-10	Field Instructions for: Painting and Preserving Electronics Command Equipment.

- TM 11-6625-317-20P Organizational Maintenance Repair Parts and Special Tools Lists: Test Set, Capacitance-Inductive, Resistance AN/URM-90, FSN 6625-534-7458.
- TM 11-6625-317-34P Direct Support and General Support Repair Parts and Special Tools Lists (Including Depot Maintenance Repair Parts and Special Tools): Test Set, Capacitance-Inductive-Resistance AN/URM-90, FSN 6625-534-7458.
- TM 38-750 The Army Maintenance Management System (TAMMS).
- TM 740-90-1 Administrative Storage of Equipment.
- TM 750-244-2 Procedure for Destruction of Equipment to Prevent Enemy Use (Electronics Command).

By Order of the Secretary of the Army:

**FRED C. WEYAND**  
*General, United States Army*  
*Chief of Staff*

Official:

**PAUL T. SMITH**  
*Major General, United States Army*  
*The Adjutant General*

**Distribution:**

*Active Army:*

USASA (2)  
Dir of Trans (1)  
COE (1)  
TSG (1)  
USAARENBD (1)  
AMC (1)  
TRADOC (2)  
ARADCOM (2)  
ARADCOM Rgn (2)  
OS Maj Comd (4)  
LOGCOMDS (3)  
MICOM (2)  
TECOM (2)  
APG (2)  
USAREUR (2)  
USARJ (2)  
USACC-EUR (2)  
USACC (4)  
MDW (1)  
Armies (2)  
Corps (2)  
HISA (Ft Monmouth) (43)  
Svc Colleges (1)  
USASESS (5)  
USAADS (2)  
USAFAS (2)  
USAARMS (2)  
USAIS (2)  
USAES (2)  
USAINTCS (3)  
WRAMC (1)  
ATS (1)  
USAEPG (2)  
JPG (2)

Fort Gordon (10)  
Fort Huachuca (10)  
WSMR (1)  
Fort Gillem (10)  
Fort Carson (5)  
Ft Richardson (ECOM Ofc) (2)  
Army Dep (1) except  
    LBAD (14)  
    SAAD (30)  
    TOAD (14)  
    SHAD (3)  
USA Dep (2)  
Sig Sec USA Dep (2)  
Sig Dep (2)  
SigFLDMS (1)  
USAERDAW (1)  
USAERDAW (1)  
MAAG (1)  
USARMIS (1)  
Units org under fol TOE:  
    (1) copy each unit  
    11-97  
    11-98  
    11-117  
    11-127  
    11-500 (AA-AC)  
    29-41  
    32-56  
    32-57  
    32-67  
    32-500  
    47  
    55-405  
    55-406

*NG:* None

*USAR:* None

For explanation of abbreviations used, see AR 310-50.



Changes in force: C 1, C 2, C 3, and C 4

TM 11-2646A  
C 4

CHANGE }  
No. 4 }

HEADQUARTERS  
DEPARTMENT OF THE ARMY  
WASHINGTON, D.C., 15 September 1966

## CAPACITANCE-INDUCTANCE-RESISTANCE TEST SET AN/URM-90

TM 11-2646A, 25 April 1956, is changed as follows:

Page 91. Add chapter 6.1 after chapter 6:

### CHAPTER 6.1

## DEPOT OVERHAUL STANDARDS

### 98.1. Applicability of Depot Overhaul Standards

The tests outlined in this chapter are designed to measure the performance capability of a repaired equipment. Equipment that is to be returned to stock should meet the standards given in these tests.

### 98.2. Applicable References

*a. Repair Standards.* Applicable procedures of the depots performing these tests and the general standard for repaired electronic equipment given in TB SIG 355-1, TB SIG 355-2, and TB SIG 355-3.

*b. Modification Work Orders.* Perform all modification work orders applicable to this equipment before making the tests specified. DA Pam 310-4 lists all available MWO's.

### 98.3. Test Facilities Required

The following items are required for depot testing:

Item	Common name
Decade Resistor ZM-16/U.....	Decade resistor.
Multimeter ME-26/U.....	Multimeter.
Frequency Meter AN/TSM-16.....	Frequency meter.
Laboratory Standards AN/URM-2.....	Laboratory Standard.
Resistance Bridge ZM-4.....	Resistance bridge.
Audio Oscillator TS-421/U.....	Audio Oscillator.

### 98.4. Oscillator Check

*a.* To check the oscillator output voltage, set the multimeter to measure ac volts on the 10-volt scale. Connect the multimeter to the EXTERNAL DETECTOR binding posts of the AN/URM-90( ). Set the D-Q multiplier dial to R, the LRC multiplier dial to 10 ohms, and the LRC dial at 0. The multimeter will read a minimum of 4.5 volts.



b. To measure the output frequency of the oscillator, leave the controls of the AN/URM-90( ) as indicated in *a* above and connect the frequency meter to the EXTERNAL DETECTOR binding posts in place of the multimeter. Adjust the frequency meter to read 1,000 cps. The frequency reading shall be 1,000 cps  $\pm$  50.

### 98.5. Bridge Circuit Test

To test the bridge circuit, use the laboratory standard or decade resistor as appropriate. Connect the components, from the laboratory standard or decade resistor one at a time, across the appropriate connectors on the AN/URM-90( ). Set the LRC MULT and LRC dials as indicated in the chart below and measure the capacitance, inductance, and resistance as appropriate. The values shall be as indicated in the chart below.

Standard	Range		Bridge reading limits
	LRC MULT	LRC dial	
200 $\mu$ f	100 $\mu$ f	2	198 to 202 $\mu$ f.
5000 $\mu$ f	1 $\mu$ f	5	4900 to 5100.
1 $\mu$ f	1 $\mu$ f	1	0.98 to 1.02 $\mu$ f.
100 $\mu$ h	100 mh	1	97 to 103 $\mu$ f.
1 mh	1 mh	1	0.97 to 1.03 mh.
100 mh	100 mh	1	98 to 102 mh.
1 ohm	0.1 ohm	10	0.98 to 1.02 ohms.
7 ohms	1 ohm	7	6.86 to 7.14 ohms.
50 ohms	10 ohms	5	49.0 to 51.0 ohms.
300 ohms	100 ohms	3	294 to 306 ohms.
2K ohms	1K ohms	2	1.96 to 2.04K ohms.
10K ohms	10K ohms	1	9.8 to 10.2K ohms.
100K ohms	100K ohms	1	98 to 102K ohms.

### 98.6. D, D-Q, and Q Dials Test

To test the D, D-Q, and Q rheostats, set the D-Q multiplier switch to R. Connect the resistance bridge across each rheostat as indicated in *a*, *b*, and *c* below, and measure the resistance.

a. Set the D dial to 2.5. The resistance bridge will read between 397.0 to 399.0 ohms.

b. Set the D-Q dial to 2.5. The resistance bridge will read between 397.0 to 399.0 ohms.

c. Set the Q dial to 0.5. The resistance bridge will read between 31.6 to 32.1 ohms.

By Order of the Secretary of the Army:

HAROLD K. JOHNSON,  
*General, United States Army,*  
*Chief of Staff.*

Official:

KENNETH G. WICKHAM,  
*Major General, United States Army,*  
*The Adjutant General.*

Distribution:

*Active Army:*

USASA (2)	318th USASA Bn (5)
CNGB (1)	319th USASA Bn (5)
CC-E (7)	320th USASA Bn (5)
Dir of Trans (1)	1st USASA Fld Sta (5)
CofEngrs (1)	2nd USASA Fld Sta (5)
TSG (1)	5th USASA Fld Sta (5)
CofSptS (1)	9th USASA Fld Sta (5)
USAAESWBD (5)	15th USASA Fld Sta (5)
USACDCEA (1)	Svc Colleges (2)
USACDCCBRA (1)	USAAMS (5)
USACDCCEA (1)	USMA (5)
USACDCCEA:	USAADS (5)
Ft Huachuca (1)	USATSCH (5)
USACDCOA (1)	USAOC&S (60)
USACDCQMA (1)	AFIP (5)
USACDCTA (1)	Instl (2) except
USACDCADA (1)	Ft Monmouth (70)
USACDCARMA (1)	Ft Gordon (10)
USACDCAVNA (1)	Ft Huachuca (10)
USACDCARTYA (1)	Ft Carson (25)
USACDCSWA (1)	Ft Knox (12)
USAMC (5)	Ft Belvoir (5)
USCONARC (5)	Ft Devens (5)
ARADCOM (5)	JCA, Ft Ritchie (5)
ARADCOM Rgn (2)	WSMR (5)
OS Maj Comd (4)	USAEPG (5)
USAREUR (5)	JPG (5)
USARJ (5)	APG (5)
LOGCOMD (2)	USASTC (2)
USAMICOM (4)	USATC Armor (2)
USASTRATCOM (4)	USATC Engr (2)
USASTRATCOM-EUR (5)	USATC Inf (2)
MDW (1)	WRAMC (1)
Armies (2)	Army Pic Cen (2)
Corps (2)	USACDCEC (10)
USAC (3)	Gen Dep (2)
100th USASA Co (5)	Sig Sec Gen Dep (5)
280th USASA Co (5)	Sig Dep (12)
507th USASA Gp (5)	

<b>A Dep (2) except</b>	<b>8-14</b>
<b>LBAD (14)</b>	<b>11-51</b>
<b>SAAD (30)</b>	<b>11-54</b>
<b>TOAD (14)</b>	<b>11-57</b>
<b>LEAD (10)</b>	<b>11-97</b>
<b>SHAD (3)</b>	<b>11-98</b>
<b>NAAD (5)</b>	<b>11-117</b>
<b>SVAD (5)</b>	<b>11-127</b>
<b>CHAD (3)</b>	<b>11-155</b>
<b>ATAD (10)</b>	<b>11-157</b>
<b>ANAD (5)</b>	<b>11-158</b>
<b>ERAD (5)</b>	<b>11-407</b>
<b>PUAD (5)</b>	<b>11-500 (AA-AC, RR)</b>
<b>RRAD (5)</b>	<b>11-587</b>
<b>Sig FLDMS (2)</b>	<b>11-592</b>
<b>AMS (1)</b>	<b>11-597</b>
<b>USAERDAA (2)</b>	<b>29-41</b>
<b>USAERDAW (13)</b>	<b>32-56</b>
<b>USACRREL (2)</b>	<b>32-57</b>
<b>USABIOLABS (5)</b>	<b>32-67</b>
<b>MM-Sig-Spt Fac (5)</b>	<b>32-68</b>
<b>Edgewood Arsenal (5)</b>	<b>32-500 (EL, TM)</b>
<b>Units organized under following</b>	<b>47</b>
<b>TOE's (2 copies each):</b>	<b>55-405</b>
<b>5-10</b>	<b>55-406</b>

**NG: State AG (3).**

**USAR: None.**

**For explanation of abbreviations used, see AR 320-50.**

Changes in force: C 1, C 2, and C 3

TM 11-2646A  
C 3

**CAPACITANCE-INDUCTANCE-RESISTANCE  
TEST SET AN/URM-90**

CHANGE }  
No. 8 }

**HEADQUARTERS  
DEPARTMENT OF THE ARMY  
WASHINGTON, D.C., 25 October 1963**

TM 11-2646A, 25 April 1956, is changed as follows:

*Page 1, paragraph 1.* Make the following changes:

Line 1. Delete the designation "a."

Delete subparagraph b.

Add paragraph 1.1.

**1.1. Index of Publications**

Refer to the latest issue of DA Pam 310-4 to determine whether there are new editions, changes, or additional publications pertaining to your equipment. DA Pam 310-4 is an index of current technical manuals, technical bulletins, supply bulletins, lubrication orders, and modification work orders available through publications supply channels. The index lists the individual parts (-10, -20, -35P, etc.) and the latest changes to and revisions of each equipment publication.

Delete paragraph 2 and substitute:

**2. Forms and Records**

*a. Reports of Maintenance and Unsatisfactory Equipment.* Use equipment forms and records in accordance with instructions in TM 38-750.

*b. Report of Damaged or Improper Shipment.* Fill out and forward DD Form 6 (Report of Damaged or Improper Shipment) as prescribed in AR 700-58 (Army), NAVSANDA Publication 378 (Navy), and AFR 71-4 (Air Force).

*c. Reporting of Equipment Manual Improvements.* The direct reporting by the individual user of errors, omissions, and recommendations for improving this manual is authorized and encour-

aged. DA Form 2028 (Recommended changes to DA technical manual parts lists or supply manual 7, 8, or 9) will be used for reporting these improvements. This form will be completed in triplicate using pencil, pen, or typewriter. The original and one copy will be forwarded direct to — Commanding Officer, U. S. Army Electronics Materiel Support Agency, ATTN: SELMS-MP, Fort Monmouth, N. J. 07703. One information copy will be furnished to the individual's immediate supervisor (officer, noncommissioned officer, supervisor, etc.).

*Page 43*, chapter 4. Make the following changes:

Delete the note under the chapter heading.

Delete section I and substitute:

#### **45. Scope of Maintenance**

The maintenance duties assigned to the operator and organizational repairman of the equipment are listed below together with a reference to the paragraphs covering the specific maintenance functions.

- a. Daily preventive maintenance checks and services (par. 48).
- b. Weekly preventive maintenance checks and services (par. 49).
- c. Monthly preventive maintenance checks and services (par. 50).
- d. Quarterly preventive maintenance checks and services (par. 51).
- e. Cleaning (par. 51.1).
- f. Touchup painting (par. 51.2).
- g. Troubleshooting (pars. 52-55).
- h. Equipment performance check (par. 56).
- i. Replacing pilot lamp (par. 57).
- j. Fuse replacement and location (par. 58).

#### **46. Preventive Maintenance**

Preventive maintenance is the systematic care, servicing, and inspection of equipment to prevent the occurrence of trouble, to reduce downtime, and to assure that the equipment is serviceable.

- a. *Systematic Care.* The procedures given in paragraphs 48

through 51.2 cover routine systematic care and cleaning essential to proper upkeep and operation of the equipment.

*b. Preventive Maintenance Checks and Services.* The preventive maintenance checks and services charts (pars. 48-51) outline functions to be performed at specific intervals. These checks and services are to maintain Army electronic equipment in a combat-serviceable condition; that is, in good general (physical) condition and in good operating condition. To assist operators in maintaining combat serviceability, the charts indicate what to check, how to check, and what the normal conditions are; the *References* column lists the illustrations, paragraphs, or manuals that contain detailed repair or replacement procedures. If the defect cannot be remedied by performing the corrective actions listed, higher echelon maintenance or repair is required. Records and reports of these checks and services must be made in accordance with the requirements set forth in TM 38-750.

#### 47. Preventive Maintenance Checks and Services Periods

Preventive maintenance checks and services of the equipment are required daily, weekly, monthly, and quarterly.

*a.* Paragraph 48 specifies the checks and services that must be accomplished daily (or at least once each week if the equipment is maintained in standby condition).

*b.* Paragraphs 49, 50, and 51 specify *additional* checks and services that must be performed on a weekly, monthly, and quarterly basis, respectively.

*Page 44.* Delete figure 13.

*Page 45,* section II. Delete the section heading and paragraphs 48 through 51 and substitute:

#### 48. Daily Preventive Maintenance Checks and Services Chart

Sequence No.	Item	Procedure	References
1	Completeness .....	See that the equipment is complete (TM 11-6625-317-12P)	
2	Exterior surfaces ..	Clean the exterior surfaces, including the panel and meter glass (par. 51.1). Check meter glass and indicator lens for cracks.	
3	Connectors .....	Check the tightness of all connectors.	

#### 48. Daily Preventive Maintenance Checks and Services Chart —Continued

Sequence No.	Item	Procedure	References
4	Controls and indicators.	While making the operating checks (item 5), observe that the mechanical action of each knob, dial, and switch is smooth and free of external or internal binding, and that there is no excessive looseness. Also, check the meter for sticking or bent pointer.	
5	Operation .....	Operate the equipment according to paragraph 56.	Par. 56.

#### 49. Weekly Preventive Maintenance Checks and Services Chart

Sequence No.	Item	Procedure	References
1	Cables .....	Inspect power cable and test leads for chafed, cracked, or frayed insulation. Replace connectors that are broken, arced, stripped, or worn excessively.	
2	Handles and latches.	Inspect handles, latches, and hinges for looseness. Replace or tighten as necessary.	
3	Metal surfaces	Inspect exposed metal surfaces for rust and corrosion. Touchup paint as required (par. 51.2).	

#### 50. Monthly Preventive Maintenance Checks and Services Chart

Sequence No.	Item	Procedure	References
1	Pluckout items	Inspect seating of pluckout items. Make certain that tube clamps grip tube bases tightly.	
2	Jacks .....	Inspect jacks for snug fit and good contact.	
3	Transformer terminals.	Inspect the terminals on the power transformer. All nuts must be tight. There should be no evidence of dirt or corrosion.	

**50. Monthly Preventive Maintenance Checks and Services Chart—Continued**

Sequence No.	Item	Procedure	References
4	Terminal blocks ....	Inspect terminal blocks for loose connections and cracked or broken insulation.	
5	Resistors and capacitors.	Inspect the resistors and capacitors for cracks, blistering, or other detrimental defects.	
6	Gasket and insulators.	Inspect gaskets, insulators, bushings, and sleeves for cracks, chipping, and excessive wear.	
7	Interior .....	Clean interior of chassis and cabinet.	

**51. Quarterly Preventive Maintenance Checks and Services Chart**

Sequence No.	Item	Procedure	References
1	Publications .....	See that all publications are complete, serviceable, and current.	DA Pam 310-4.
2	Modifications .....	Check DA Pam 310-4 to determine if new applicable MWO's have been published. All URGENT MWO's must be applied immediately. All NORMAL MWO's must be scheduled.	TM 38-750 and DA Pam 310-4.
3	Spare parts .....	Check all spare parts (operator and organizational) for general condition and method of storage. There should be no evidence of overstock, and all shortages must be on valid requisitions.	TM 11-6625-317-12P

Add paragraphs 51.1 and 51.2.

**51.1. Cleaning**

Inspect the exterior of the equipment. The exterior surfaces should be clean, and free of dust, dirt, grease, and fungus.

a. Remove dust and loose dirt with a clean soft cloth.

**Warning:** Cleaning compound is flammable and its fumes are toxic. Provide adequate ventilation. *Do not* use near a flame.



b. Remove grease, fungus, and ground-in dirt from the cases ; use a cloth dampened (not wet) with Cleaning Compound (Federal stock No. 7980-395-9542).

c. Remove dust or dirt from plugs and jacks with a brush.

**Caution:** Do not press on the meter face (glass) when cleaning ; the meter may become damaged

d. Clean the front panel, meter, and control knobs ; use a soft clean cloth. If necessary, dampen the cloth with water and mild soap.

## 51.2. Touch Painting Instructions

Remove rust and corrosion from metal surfaces by lightly sanding them with fine sandpaper. Brush two thin coats of paint on the bare metal to protect it from further corrosion. Refer to the applicable cleaning and refinishing practices specified in TM 9-218.

*Page 47.* Delete figure 14.

*Page 102.* Add the following appendix after chapter 7.

## APPENDIX REFERENCES

---

DA Pam 310-4	Index of Technical Manuals, Technical Bulletins, Supply Bulletins, Lubrication Orders, and Modification Work Orders.
TM 9-218	Painting Instructions for Field Use.
TM 11-6625-317-12P	Operator's Organizational Maintenance Repair Parts and Special Tools List and Maintenance Allocation Chart: Test Set, Capacitance-Inductance-Resistance AN/URM-90.
TM 11-6625-317-35P	Field and Depot Maintenance Repair Parts and Special Tools List: Test Set, Capacitance-Inductance-Resistance AN/URM-90.
TM 38-750	The Army Equipment Record System and Procedures.

**BY ORDER OF THE SECRETARY OF THE ARMY:**

**EARLE G. WHEELER,**  
*General, United States Army,*  
*Chief of Staff.*

**Official:**

**J. C. LAMBERT,**  
*Major General, United States Army,*  
*The Adjutant General.*

**Distribution:**

**Active Army:**

DASA (6)  
USASA (2)  
CNGB (1)  
CSigO (7)  
CofT (1)  
CofEngrs (1)  
TSG (1)  
CofSpt Svcs (1)  
USAMC (5)  
USCONARC (5)  
ARADCOM (2)  
ARADCOM Rgn (2)  
USASMCOM (1)  
USAECOM (7)  
USAMICOM (4)  
OS Maj Comd (3)  
OS Base Comd (2)  
LOGCOMD (2)  
MDW (1)  
Armies (2)  
Corps (2)  
USA Corps (3)  
USAAESBD (2)  
Instl (2) except  
    Ft Monmouth (65)  
    Ft Hancock (4)  
Svc Colleges (2)  
Br Svc Sch (2)  
USAECDA (1)  
USACBECDA (1)  
USACECDA (1)  
USAMSCDA (1)  
USAOEDA (1)  
USAQMCDA (1)  
USATCDA (1)  
USAADCDA (1)  
USAARMCDA (1)

**USAAVNCDA (1)**  
**USAAARTYCDA (1)**  
**USASWCDA (1)**  
**AFIP (1)**  
**AMS (1)**  
**Chicago Proc Dist (1)**  
**USASCC (4)**  
**GENDEP (OS) (2)**  
**Sig Sec, GENDEP (OS) (5)**  
**Sig Dep (OS) (12)**  
**Yuma PG (2)**  
**USMA (5)**  
**USATC FA (2)**  
**USATC AD (2)**  
**USATC Armor (2)**  
**USATC Engr (2)**  
**USATC Inf (2)**  
**USASTC (2)**  
**WRAMC (1)**  
**Army Pic Cen (2)**  
**USA Mbl Spt Cen (1)**  
**USA Trans Tml Comd (1)**  
**USA Elct Mat Agcy (12)**  
**USA Comm Elct CD Agcy (Ft Monmouth) (1)**  
**USARSOUTHCOM Sig Agcy (1)**  
**Army Dep (2) except**  
    **Lexington (12)**  
    **Sacramento (28)**  
    **Tobyhanna (12)**  
    **Ft Worth (5)**  
    **Anniston (5)**  
    **Erie (5)**  
    **Pueblo (5)**  
**Army Tml (1)**  
**POE (1)**  
**Sig Fld Maint Shops (8)**  
**USA Elct Rsch & Dev Acty (Ft Huachuca) (2)**  
**USA Elct RD Acty (White Sands) (13)**  
**WSMR (5)**  
**APG (5)**  
**Units org under fol TOE: (2 copies**  
    **each except as indicated)**  
    11-7  
    11-16  
    11-57  
    11-97  
    11-98  
    11-117  
    11-155  
    11-157  
    11-500 (AA-AE) (4)  
    11-557  
    11-587  
    11-592

**11-597**  
**32-56**  
**32-57**  
**32-68**

**NG: State AG (3).**

**USAE: None.**

**For explanation of abbreviations used, see AR 320-50.**



TECHNICAL MANUAL  
CAPACITANCE-INDUCTANCE-RESISTANCE  
TEST SET AN/URM-90

TM 11-2646A

CHANGES No. 2

HEADQUARTERS  
DEPARTMENT OF THE ARMY  
WASHINGTON 25, D.C., 28 December 1961

TM 11-2646A, 25 April 1956, is changed as indicated so that the manual also applies to the following equipment:

<i>Nomenclature</i>	<i>Order No.</i>	<i>Serial No.</i>
Capacitance-Inductance-Resistance Test Set AN/URM-90.	4430-PP-61-A3-A3	1-596

*Note:* The parenthetical reference to previous Changes (example: "page 8 of C 1") indicates that pertinent material was published in that Changes.

*Page 3.* Add paragraph 4.1 after paragraph 4.

#### 4.1. Differences in Circuitry (Added)

The following changes have been made on Order No. 4430-PP-61-A3-A3.

a. Capacitance-Inductance-Resistance Test Set AN/URM-90 has been changed to include resistors R10, R67, and R68 at section 2 of circuit selector switch S6. Resistor R10 at terminal 1 of LRC dial multiplier switch S5 has been removed and the values of R7, R8, and R9 have been changed. The above changes were made in the following circuits to improve the accuracy:

- (1) Wheatstone resistance bridge circuit (chart, fig. 20).
- (2) Modified De Santy capacitance bridge circuit (chart, fig. 21).
- (3) Maxwell inductance bridge circuit (chart, fig. 22).
- (4) Hay inductance bridge circuit (chart, fig. 23).

b. The resistor reference designations at LRC dial switches S4 and S8 and the terminal numbers at circuit selector switch S6 have been changed, but the circuitry and functions remain the same.

*Page 65,* paragraph 61a, line 4. Add the following after the second sentence:

On Order No. 4430-PP-61-A3-A3, section 2 of S6 also selects R10, R67, or R68 (fig. 37.1) as part of the ratio A arm. Resistor R10 (1 ohm) at terminal 1 of S5 has been removed and a short-

ing wire is used in its place since R10, R67, and R68 (added at section 2 of S6) are approximately 1 ohm.

Figure 20. Add the following below the existing chart:

Order No. 4430-PP-61-A3-A3		
SWITCH POSITION	R <sub>A</sub>	Total R
0.1Ω	R67	1.0
1Ω	R67, R9	10
10Ω	R67, R8	100
100Ω	R67, R7	1,000
1KΩ	R67, R6	10K
10KΩ	R67, R5	100K
100KΩ	R67, R5, R4	1 MEG

Page 67, figure 21. Add the following below the existing chart:

Order No. 4430-PP-61-A3-A3		
SWITCH POSITION	R <sub>A</sub>	Total R
100μF	R68	1.0
10μF	R68, R9	10
1μF	R68, R8	100
0.1μF	R68, R7	1,000
.01μF	R68, R6	10K
.001μF	R68, R5	100K
.0001μF	R68, R5, R4	1 MEG

Page 68, figure 22. Delete "R<sub>b</sub> 0-1,670." Add the following below the existing chart:

Order No. 4430-PP-61-A3-A3		
SWITCH POSITION	R <sub>A</sub>	Total R
0.1MH	R10	1.0
1MH	R10, R9	10
10MH	R10, R8	100
100MH	R10, R7	1,000
1H	R10, R6	10K
10H	R10, R5	100K
100H	R10, R5, R4	1 MEG

Page 69, figure 23. Add the following below the existing chart.

Order No. 4430-PP-61-A3-A3		
SWITCH POSITION	R <sub>A</sub>	Total R
0.1MH	R10	1.0
1MH	R10, R9	10
10MH	R10, R8	100
100MH	R10, R7	1,000
1H	R10, R6	10K
10H	R10, R5	100K
100H	R10, R5, R4	1 MEG

Page 85, figure 32. after "R4 through R10" Add: (NOTE).  
Add the following note to figure 32:

NOTE

R4 THROUGH R9 (ON ORDER NO. 4430-PP-61-A3-A3).

Page 94, paragraph 88.2 (page 16 of C 1). Add paragraph 88.2.1 after paragraph 88.2.

### **88.2.1 Replacing LRC Dial Multiplier, Switch S5, Circuit Selector Switch S6, and Switch S7 (Order No. 4430-PP-61-A3-A3)**

a. *Removing Switches S5, S6, and S7* (figs. 30 and 32).

*Note:* The bus wires may be slightly bent or displaced for parts removal. If bending is necessary, be very careful to avoid extreme bends. Attach tags to all bus wire lugs as they are removed from terminals. On the tags, note the part and terminal from which the lug was removed. Note the positions of all knobs and wiper arms to aid in reassembly.

- (1) Remove the bridge chassis from the carrying case (par. 51b(2)).
- (2) Remove capacitor C2 (par. 72a).
- (3) Remove the black plastic mounting board for capacitor C2 (par. 88.1a(3)).
- (4) Use the No. 10 Allen wrench and loosen the two setscrews in the side of the knob and pointer (1, A, fig. 33.4). Remove the knob and pointer (1) from the inner shaft and bushing assembly (16).
- (5) Turn the circuit selector lever (2) to the extreme counterclockwise position and, with the No. 10 Allen wrench, loosen the two setscrews in the side of the circuit selector lever (2). The setscrews are located on the part of the circuit selector lever that protrudes through the front panel (6). These setscrews must be completely removed and set aside. The circuit selector lever (2) is loose but cannot be removed until the calibrated indicator disk (4) is removed ((6) below).
- (6) Remove the two machine screws (3) that attach the calibrated indicator disk (4) to the front panel (6). Simultaneously remove the calibrated indicator disk (4) from the panel and the circuit selector lever (2) from the outer shaft and bushing assembly (29).
- (7) Disconnect one end of bus wire A (B, fig. 33.4) from the rear of binding post C (red, high) (fig. 5) by removing the hexagonal nut from the rear of binding post C (red, high). When the nut is removed, pull the bind-



ing post stud forward until the bus wire and its soldering lug may be displaced slightly to one side. Replace the binding post and replace the hexagonal nut.

*Note:* The bus wires may be slightly bent or displaced for replacement purposes. If bending is necessary, be very careful. Avoid extreme bends. Attach tags to all bus wire lugs removed from the terminals or binding post studs for identification purposes. On the tags, identify the terminal from which the individual lug was removed.

- (8) Unsolder the flexible pigtail lead located at the approximate center of the horizontal portion of bus wire A (B, fig. 33.4).
- (9) Disconnect one end of bus wire B from the binding posts on the front panel (6). Bus wire B is secured at the disconnect end by binding posts C LO and LR LO. Remove the hexagonal nuts from these binding posts and pull the two binding post studs forward until bus wire B and its soldering lugs can be displaced slightly downward. Replace the binding posts and replace the hexagonal nuts. A black lead wire is soldered to the bus wire B soldering lug which is anchored to binding post LR LO. Unsolder and tag this black lead.
- (10) Disconnect one end of bus wire C. Bus wire C may be unsoldered at either the switchboard and resistor assembly (38, A, fig. 33.4) or the switchboard and resistor assembly (28).
- (11) Bus wire D (B, fig. 33.4) is terminated at the disconnect end by a soldering lug connected to a terminal stud on capacitor C2, and is disconnected when capacitor C2 is removed ((2) above). Unsolder and disconnect the end of bus wire F at the point where the wire loops over bus wire E.
- (12) Unsolder and disconnect the end of bus wire E that terminates at the switchboard and resistor assembly (38, A, fig. 33.4).
- (13) Disconnect one end of bus wire G (B, fig. 33.4) from the rear of binding post EXT. D-Q (red, high) (fig. 5) by removing the hexagonal nut from this post and pulling the binding post stud forward until the bus wire and its soldering lug can be displaced slightly to one side. Replace the binding post and the hexagonal nut.

- (14) Unsolder and disconnect bus wire H (B, fig. 33.4) at microswitch S7 (34, A, fig. 33.4).
- (15) Unsolder and disconnect the ends of bus wires J, K, L, and M (B, fig. 33.4) which terminate at the switchboard and resistor assembly (28, A, fig. 33.4).

**Caution:** Be extremely careful when using a soldering iron near resistors R4 through R10, R22, R23, R67, and R68. These are precision resistors, and prolonged exposure to the heat generated by the soldering iron may affect the accuracy of the parts.

- (16) Remove the three machine screws (5). Carefully remove the LRC dial multiplier, the circuit selector switch, and the microswitch S7 assembly from the rear of the front panel (6). Be sure that all bus wires and associated lugs have been displaced sufficiently to prevent damage.
- (17) Remove the four machine screws (39), lockwashers (8) and plain washers (9) from the switchboard and resistor assembly (38).

**Caution:** Be extremely careful when using a soldering iron near resistors R4 through R10, R22, R23, R67, and R68. These are precision resistors, and prolonged exposure to the heat generated by the soldering iron may affect the accuracy of the parts.

- (18) Unsolder one end of the three precision resistors which terminate at switchboard and resistor assembly (38).
- (19) Use a screwdriver to prevent the machine screws (35) from turning, and remove the four hexagonal spacers (7), lockwashers (8), and plain washers (9) from the machine screws (35).
- (20) Unsolder one end of flexible pigtail lead N (B, fig. 33.4) at the contact ring assembly for S5 (13, A, fig. 33.4). Use the No. 10 Allen wrench to loosen the two setscrews in the side of the contact ring assembly for S5 (13). Remove the assembled switchboard and resistor assembly (15) and the contact ring assembly for S5 (13) from the four machine screws (35).
- (21) Disassemble the contact ring assembly for S5 (13) from the switchboard and resistor assembly (15) by removing the two machine screws (12), hexagonal nuts

- (10), and lockwashers (11). The lockwasher (14) will fall free when the assemblies are detached.
- (22) Remove the inner shaft and bushing assembly (16) from the outer shaft and bushing assembly (29) and set it aside.
- (23) Use the No. 10 Allen wrench to loosen the two set-screws in the side of the contact and bushing assembly (17), and remove the bushing assembly from the outer shaft and bushing assembly (29).
- (24) Remove the two spacers (18), mounting brackets (19), and spacers (20) from the two left-side machine screws (35), and the two spacers (21) from the two right-side machine screws (35).
- (25) Use the No. 10 Allen wrench and loosen the two set-screws in the side of the contact and bushing assembly (22); remove the assembly from the outer shaft and bushing assembly (29).
- (26) Use the No. 10 Allen wrench and loosen the two set-screws in the side of the contact ring assembly (26). Remove the outer shaft and bushing assembly (29) and set it aside. Remove the assembled switchboard and resistor assembly (28) and the contact ring assembly (26) from the four machine screws (35).
- (27) Unsolder one end of the flexible lead (37) at the contact ring assembly (26).
- (28) Disassemble the contact ring assembly (26) from the switchboard and resistor assembly (28) by removing the two machine screws (25), hexagonal nuts (23), and lockwashers (24). The lockwasher (27) will fall free when the contact ring assembly (26) is removed.
- (29) Remove the four spacers (30) from the four machine screws (35). Remove the four machine screws (35) from the mounting plate (36).
- (30) Remove microswitch S7 (34) from the mounting plate (36) by unscrewing and removing the two machine screws (33), hexagonal nuts (31), and lockwashers (32).

*b. Reassembling Switches S5, S6, and S7.*

*Note:* During assembly, carefully follow the instructions that were recorded on the tags in the disassembly procedure.

- (1) Attach the microswitch (34, A, fig. 33.4) to the mount-

- ing plate (36) with the two machine screws (33), hexagonal nuts (31), and lockwashers (32).
- (2) Insert the four machine screws (35) in the four corner holes of the mounting plate (36) and replace the four spacers (30) on the threaded ends of the four machine screws (35).
  - (3) Mount the contact ring assembly (26) and aline with the detent in switchboard assembly (28). Place the lockwasher (27) on the switchboard and resistor assembly (28). Secure the assemblies with the two machine screws (25), hexagonal nuts (23), and lockwashers (24). Resolder the end of the flexible lead (37) to the contact ring assembly (26).
  - (4) Replace the assembled switchboard and resistor assembly (28) and the contact ring assembly (26) on the four machine screws (35) adjacent to the four spacers (30).
  - (5) Insert the outer shaft and bushing assembly (29) through the center openings of the contact ring assembly (26) and the switchboard and resistor assembly (28). Adjust the outer shaft and bushing assembly (29) until approximately  $1\frac{1}{4}$  inches is measured between the forward end of the outer shaft and bushing assembly (29) and the forward face of the contact ring assembly (26).
  - (6) Use the No. 10 Allen wrench to tighten the two setscrews in the side of the contact ring assembly (26).
  - (7) Slide the contact and bushing assembly (22) on the outer shaft and bushing assembly (29). The wiper arm of the contact and bushing assembly (22) functions with the contact ring assembly (26) which is located in its proper operating position through the detent in the switchboard and resistor assembly (28); both bushing and ring assemblies are controlled through the knob and pointer (1). The wiper arm of the contact and bushing assembly (22) and the contact ring assembly (26) must be on the same contact position in respect to each other on both sides of the switchboard and resistor assembly (28). Be sure that the wiper arm of the contact and bushing assembly (22) maintains sufficient pressure against the switch contacts on the switchboard and resistor assembly (28). Use a No. 10 Allen wrench to

- tighten the two setscrews in the side of the contact and bushing assembly (22).
- (8) Replace the two spacers (21) on the two right-side machine screws (35) and the two spacers (20), mounting brackets (19), and spacers (18) on the two left-side machine screws (35).
  - (9) Slide the contact and bushing assembly (17) on the outer shaft and bushing assembly (29). Do not tighten the setscrews in the side of the bushing.
  - (10) Replace the contact ring assembly (13) and align it with the detent in switchboard and resistor assembly (15). Place the lock washer (14) on the switchboard and resistor assembly (15) and secure it with the two machine screws (12), lockwashers (11), and hexagonal nuts (10).
  - (11) Insert the inner shaft and bushing assembly (16) into the outer shaft and bushing assembly (29) through the contact and bushing assembly (17).
  - (12) Carefully replace the assembled switchboard and resistor assembly (15) and the contact ring assembly (13) on the four machine screws (35) so that the inner diameter of the contact ring assembly (13) rests on the large diameter part of the inner shaft and bushing assembly (16).
  - (13) Replace the four plain washers (9), lockwashers (8), and hexagonal spacers (7) on the threaded ends of the four machine screws (35). If necessary, use a screwdriver to keep the machine screws from turning while the four hexagonal spacers (7) are being tightened.
  - (14) Position the contact and bushing assembly (17) on the outer shaft and bushing assembly (29) so that the wiper arms of the contact and bushing assembly (17) and the contact ring assembly (13) are on the same contact position in respect to each other on both sides of the switchboard and resistor assembly (15). Both the contact ring assembly (13) and the contact and bushing assembly (17) are controlled by the circuit selector lever (2). Be sure that the wiper arm of the contact and bushing assembly (17) maintains sufficient pressure against the switch contacts on the switchboard and resistor assembly (15). Use a No. 10 Allen wrench to tighten the

two setscrews in the side of the contact and bushing assembly (17).

- (15) Use the No. 10 Allen wrench and tighten the two setscrews in the side of the contact ring assembly (13).
- (16) Place the LRC dial multiplier circuit selector switch and the microswitch S7 assembly in position against the back of the front panel (6). Aline the tapped holes in the mounting plate (36) with the matching holes in the front panel (6), and replace the three machine screws (5).
- (17) Carefully work the bushing end of the circuit selector level (2) through from the front of the calibrated indicator disk (4). Carefully aline the raised detent of the circuit selector lever (2) with the notched cutout in the front panel, and replace the circuit selector lever (2) on the outer shaft and bushing assembly (29).
- (18) Replace the two setscrews in the bushing of the circuit selector lever (2), and tighten them with the No. 10 Allen wrench.
- (19) Position the calibrated indicator disk (4) against the front panel (6) so that the two mounting holes of the calibrated indicator disk (4) are alined with the tapped holes in the front panel (6). Replace the two machine screws (3).
- (20) Replace the knob and pointer (1) on the inner shaft and bushing assembly (16) and tighten the two setscrews in the side of the knob and pointer (1) with a No. 10 Allen wrench.
- (21) Resolder the ends of bus wires J, K, L, and M (B, fig. 33.4) to their respective terminals on the switchboard and resistor assembly (28, A, fig. 33.4).

**Caution:** Be extremely careful when using a soldering iron near resistors R4 through R10, R22, R23, R67, and R68. These are precision resistors, and prolonged exposure to the heat generated by the soldering iron may affect the accuracy of the parts.

- (22) Connect and solder the end of bus wire H (B, fig. 33.4) to microswitch S7 (34, A, fig. 33.4).
- (23) Reconnect the end of bus wire G (B, fig. 33.4) to binding post EXT. D-Q (red, high) (fig. 5). Remove as follows:

the hexagonal nut from the rear of the post and pull the binding post stud forward until the bus wire and the attached soldering lug can be maneuvered into alignment with the binding post stud. Insert the binding post stud into the soldering lug. Replace the hexagonal nut and tighten it.

- (24) Replace the switchboard and resistor assembly (38). Do not tighten the machine screw (39).

**Caution:** Be extremely careful when using a soldering iron near resistors R4 through R10, R22, R23, R67, and R68. These are precision resistors, and prolonged exposure to the heat generated by the soldering iron may affect the accuracy of the parts.

- (25) Reconnect and solder the ends of three precision resistors R10, R67, and R68 to the proper points on the switchboard and resistor assembly (38).
- (26) Tighten the four machine screws (39).
- (27) Reconnect and solder the end of bus wire E to its terminal on the switchboard and resistor assembly (38 A, fig. 33.4). Reconnect and solder bus wire F (B, fig. 33.4) to bus wire E at the point shown in B, figure 33.4.
- (28) Reconnect and solder the disconnected end of bus wire C (B, fig. 33.4), depending on the point of disconnection (a(10) above).
- (29) Remove the hexagonal nuts from binding posts C LO and LR LO, and pull the binding post studs forward. Aline the two soldering lugs attached to bus wire B, with their respective studs. Replace the studs so that they pass through the soldering lugs. Resolder the black lead wire to the bus wire B soldering lug that is attached to binding post LR LO. Replace and tighten the two hexagonal nuts on the binding posts.
- (30) Resolder the flexible pigtail lead that connects to the approximate center of the horizontal portion of bus wire A.
- (31) Reconnect the end of bus wire A to binding post C (red, high) (fig. 5) by removing the hexagonal nut from the rear of this post. Pull the binding post stud forward until the bus wire and the soldering lug can be maneuvered into alignment with the binding post stud. Insert

the stud through the soldering lug. Replace and tighten the hexagonal nut on the binding post.

- (32) Replace and solder the end of flexible lead N to the contact ring assembly (13, A, fig. 33.4).
- (33) Replace the black plastic mounting board for capacitor C2 by reassembling the four machine screws, hexagonal nuts, and lockwashers that secure the mounting board to the four capacitor mounting brackets.
- (34) Replace capacitor C2 (par. 72b).
- (35) Replace the bridge chassis in the carrying case (par. 51b(11)).

BY ORDER OF THE SECRETARY OF THE ARMY:

G. H. DECKER,  
*General, United States Army,*  
*Chief of Staff.*

Official:

J. C. LAMBERT,  
*Major General, United States Army,*  
*The Adjutant General.*

Distribution:

*Active Army:*

DASA (6)  
USASA (2)  
CNGB (1)  
Tech Stf, DA (1) except  
CSigO (18)  
Tech Stf Bd (1)  
USCONARC (5)  
USAARTYBD (1)  
USAARMBD (2)  
USAIB (1)  
USARADB (2)  
USAABELCTBD (1)  
USAAVNBD (1)  
USAAATBD (1)  
ARADCOM (2)  
ARADCOM, Rgn (2)  
OS Maj Comd (3)  
OS Base Comd (2)  
LOGCOMD (2)  
MDW (1)  
Armies (2)  
Corps (2)

Instl (2)  
Fort Monmouth (63)  
USATC AD (2)  
USATC Armor (2)  
USATC Engr (2)  
USATC FA (2)  
USATC Inf (2)  
USAOMC (3)  
Svc Colleges (2)  
Br Svc Sch (2)  
GENDEP (2) except  
Atlanta GENDEP (none)  
Sig Sec, GENDEP (5)  
Sig Dep (12)  
WRAMC (1)  
USA Trans Tml Comd (1)  
Army Tml (1)  
POE (1)  
OSA (1)  
USAEPG (2)  
AFIP (1)  
AMS (1)



**TM 11-2646A**  
**C 2**

	Units org under fol TOE:
Army Pictorial Cen (2)	11-7 (2)
EMC (1)	11-16 (2)
Yuma Test Sta (2)	11-57 (2)
USACA (3)	11-97 (2)
USASSA (20)	11-117 (2)
USASSAMRO (1)	11-155 (2)
USASEA (1)	11-157 (2)
USA Caribbean Sig Agcy (1)	11-500 (AA-A-E) (4)
USA Sig Msl Spt Agcy (13)	11-557 (2)
Sig Fld Maint Shops (3)	11-587 (2)
USA Corps (3)	11-592 (2)
JBUSMC (2)	11-597 (2)
AFSSC (1)	32-57 (2)
APG (5)	

*NG*: State AG (3).

*USAR*: None.

For explanation of abbreviations used, see AR 320-50.

☆ U. S. GOVERNMENT PRINTING OFFICE: 1962—610324/2636B



**TM 11-2646A****C 2**

- 1 Knob and pointer
- 2 Circuit selector lever
- 3 Machine screw, No. 4-40 by 5/32 inch long, brass, nickel plated, binding head
- 4 Calibrated indicator disk
- 5 Machine screw, No. 8-32 by 3/8 inch long, brass, nickel plated, flathead
- 6 Front panel
- 7 Hexagonal spacer No. 10-24
- 8 Lockwasher, No. 10, split
- 9 Plain washer, .438 inch OD by .203 inch ID by .032 inch thick
- 10 Hexagonal nut, No. 6-32
- 11 Lockwasher, No. 6, split
- 12 Machine screw, No. 6-32 by 1/2 inch long, brass, cadmium plated, flathead
- 13 Contact ring assembly for S5
- 14 Lockwasher, No. 6, internal tooth
- 15 Switchboard and resistor assembly (part of S5 and S6 and includes R4-R10)
- 16 Inner shaft and bushing assembly
- 17 Contact and bushing assembly (part of S6)
- 18 Spacer, .313 inch OD by .215 inch ID by 7/16 inches long
- 19 Mounting bracket
- 20 Spacer, .313 inch OD by .215 inch ID by 1 15/16 inches long, aluminum
- 21 Spacer, .313 inch OD by .215 inch ID by 2 7/16 inches long, aluminum
- 22 Contact and bushing assembly (part of S6)
- 23 Hexagonal nut, No. 6-32
- 24 Lockwasher, No. 6, split
- 25 Machine screw, No. 6-32 by 1/2 inch long, brass, cadmium plated, flathead
- 26 Contact ring assembly (part of S5)
- 27 Lockwasher, No. 6, internal tooth
- 28 Switchboard and resistor assembly (part of S6 and includes R22 and R23)
- 29 Outer shaft and bushing assembly
- 30 Spacer, .313 inch OD by .215 inch ID by 1 5/16 inch long, aluminum
- 31 Hexagonal nut, No. 2-56
- 32 Lockwasher, No. 2, split
- 33 Machine screw, No. 2-56 by 3/4 inch long, brass, nickel plated, flathead
- 34 Microswitch (S7)
- 35 Machine screw, No. 10-24 by 4 1/2 inches long, steel, nickel plated, flathead
- 36 Mounting plate
- 37 Flexible lead
- 38 Switchboard and resistor assembly
- 39 Machine screw No. 10-24 by 3/8 inch long, brass, nickel-plated binding head.

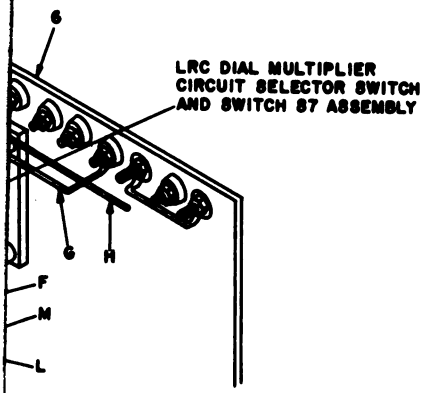
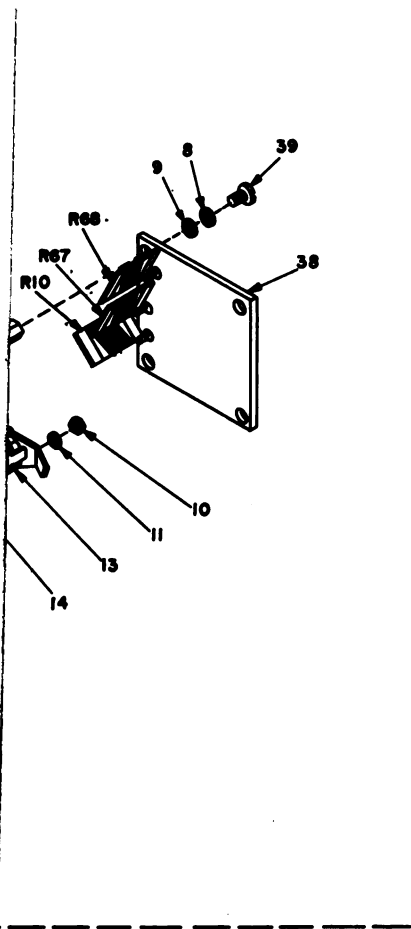

WHICH MUST BE

TN2646A-C2-2

Figure 33.4



NOTES:

UNLESS OTHERWISE SHOWN, RESISTANCES ARE IN OHMS, CAPACITANCES ARE IN UUF

▭ INDICATES EQUIPMENT MARKING

SWITCH S5 IS VIEWED FROM THE REAR

SECTION I OF SWITCH S6 IS NEAREST TO CONTROL KNOB

SWITCHES S4 AND S8, AND VARIABLE RESISTOR R36 COMPRISE THE **LRC** DIAL

**DETECTOR** SWITCH S1 AND **GENERATOR** SWITCH S12 ARE VIEWED FROM REAR. SECTION I OF SWITCH S12 IS NEAREST TO CONTROL KNOB

**DETECTOR** IS SHOWN IN METER POSITION

**GENERATOR** SWITCH IS SHOWN IN **DC HI** POSITION

CONTACTS MADE IN EACH POSITION OF SWITCH S5 AS FOLLOWS

SWITCH POSITION			CONTACT
L	R	C	
0.1MH	0.1	100UF	1
1MH	1	10UF	2
10MH	10	1UF	3
100MH	100	0.1UF	4
1H	1K	0.01UF	5
10H	10K	0.001UF	6
100 H	100 K	0.0001UF	7

SWITCH S7 CLOSSES WHEN S6 IS IN THE **L**, **D-EXT** POSITION

DASHED LINE INDICATES JUMPER PLACED BETWEEN **EXT. D-G** BINDING POSTS WHEN EXTERNAL DECADE RESISTOR IS NOT CONNECTED

TM2646A-C2-4

Figure 37.1



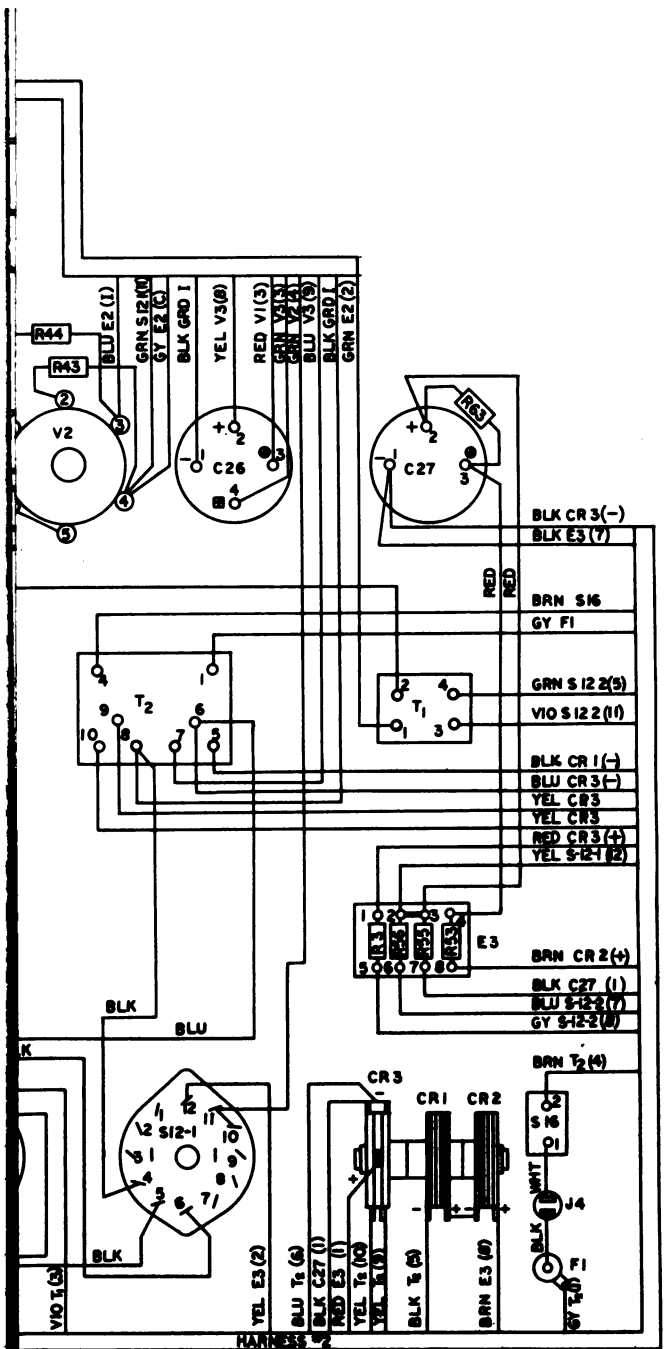

TN2646A-C2-3

Inductance-Resistance Test  
 P. 4430-PP-61-A3-A3),  
 gram.

Figure 38.1





TECHNICAL MANUAL  
CAPACITANCE-INDUCTANCE-RESISTANCE  
TEST SET AN/URM-90

TM 11-2646A }  
CHANGES No. 1 }

DEPARTMENT OF THE ARMY  
WASHINGTON 25, D. C., 20 November 1956

TM 11-2646A, 25 April 1956, is changed as follows:

Page 12, paragraph 14c. Make the following changes:

In the last sentence, change "tens" to read: **units**.

Table, column 1, item 1. Change "Tens (outer dial)" to read:  
**Units (outer dial)**.

**88.1. Replacing Variable Resistors R21, R24, and R25 on Q and D-Q Dial Assembly**  
(Added)

a. *Removing Variable Resistors R21, R24, and R25 (fig. 30).*

- (1) Remove the bridge chassis from the carrying case (par. 51b(2)).
- (2) Remove capacitor C2 (par. 72a).
- (3) Remove the black plastic mounting board for capacitor C2 by removing the four machine screws, hexagonal nuts, and lockwashers that attach the mounting board to the four capacitor mounting supports. For reassembly purposes, note the positions of the two wire clips on the right side of the mounting board, facing the front panel of the bridge.
- (4) Carefully note the dial and pointer settings (par. 71c). Remove the two machine screws (A, 1, fig. 33.1), the dial alinement guide (2), and the two spacers (3).
- (5) Use the No. 10 Allen wrench and loosen the two setscrews that secure the Q and D-Q dial plate (4). Pull the dial plate (4) from the shaft and bushing assembly (36). The fine adjustment knob assembly (5) will pull free from its sleeve as the dial plate is being removed.

*Note.* Bus wires may be slightly bent or displaced for parts removal. If bending is necessary, be very careful and avoid extreme bends. Tags must be attached to all bus wire lugs as they are removed from terminals. On the tags, note the part and terminal from which the lug was removed.

- (6) Disconnect one end of bus wire A (B, fig. 33.1) from variable resistor R25 (A, 31, fig. 33.1) by removing the terminal retaining nut and lifting the bus wire and its attached lug from the terminal.
- (7) Disconnect one of the ends of bus wire B (B, fig. 33.1) by removing the two terminal retaining nuts on variable resistor R25 (A, 31, fig. 33.1) and lifting the bus wire and the two attached lugs from the terminals. To complete disconnecting one end of bus wire B (B, fig. 33.1), remove the middle terminal retaining nut on the bottom of variable resistor R24 (A, 24, fig. 33.1) and the right-hand terminal retaining nut on the bottom of variable resistor R21 (15). Remove the bus wire ends and attached lugs from the terminals.
- (8) Disconnect one end of bus wire C (B, fig. 33.1) from variable resistor R24 (A, 24, fig. 33.1) by removing the right-hand terminal retaining nut and disconnecting the bus wire and its attached lug from the terminal.
- (9) Disconnect one end of bus wire D (B, fig. 33.1) from variable resistor R24 (A, 24, fig. 33.1) by removing the left-hand terminal retaining nut and disconnecting the bus wire and its attached lug from the terminal.
- (10) Disconnect one end of bus wire E (B, fig. 33.1) from variable resistor R21 (A, 15, fig. 33.1) by removing the left-hand and middle terminal retaining nuts and disconnecting the bus wire and its attached lugs from the terminals.
- (11) Remove the three machine screws (6) and carefully remove the Q and D-Q dial assembly from the rear of the front panel (7). Be sure that all bus wires and associated lugs are sufficiently displaced so they will not be damaged while the assembly is being removed.
- (12) Use the No. 10 Allen wrench and loosen the two setscrews in the side of the contact and collar assembly for R21 (8); remove it and the spring washer (9) from the shaft and bushing assembly (36).
- (13) Use a screwdriver to prevent the machine screws (33) from turning, and remove the four hexagonal nuts (10), lockwashers (11), and plain washers (12) from the machine screws (33).
- (14) Remove the assembled R21 mounting board (16) and variable resistor R21 (15) from the machine screws (33).

- (15) Unscrew the three machine screws (13) from the hexagonal nuts (14) to remove variable resistor R21 (15) from the R21 mounting board (16).
- (16) Remove the two left side spacers (17), two mounting brackets (18), and two right side spacers (19) from the machine screws (33).

*Note.* The left side spacer (17) is slightly longer than the right side spacer (19). These spacers are not interchangeable.

- (17) Use the No. 10 Allen wrench and loosen the two setscrews in the side of the contact and collar assembly for R24 (20); remove it and the spring washer (21) from the shaft and bushing assembly (36).
- (18) Remove the assembled R24 mounting board (25) and variable resistor R24 (24) from the machine screws (33).
- (19) Unscrew the three machine screws (22) from the three hexagonal nuts (23) to remove variable resistor R24 (24) from the R24 mounting board (25).
- (20) Remove the four spacers (26) from the machine screws (33).
- (21) Use the No. 10 Allen wrench and loosen the two setscrews in the side of the contact and collar assembly for R25 (27); pull it and the spring washer (28) from the shaft and bushing assembly (36).
- (22) Remove the shaft and bushing assembly (36), the spring washer (35), and the attached collar (34) from the front of the assembled R25 mounting board (32) and variable resistor R25 (31).
- (23) Remove the four machine screws (33) from the R25 mounting board (32) and variable resistor R25 (31).
- (24) Unscrew the three machine screws (29) from the three hexagonal nuts (30) to remove variable resistor R25 (31) from the R25 mounting board (32). Remove the four machine screws (33) from the mounting board (32).
- (25) Use the No. 10 Allen wrench and loosen the two setscrews in the side of the collar (34); remove it and the spring washer (35) from the shaft and bushing assembly (36).

*b. Reassembling Variable Resistors R21, R24, and R25.*

- (1) Slide the collar (A, 34, fig. 33.1) onto the shaft and bushing assembly (36) from the knob end. Position the collar (34) on the shaft so that the collar face nearest the knob end is approximately three-fourths of an inch from the knob end. Use a No. 10 Allen wrench to tighten

- the two setscrews on the side of the collar (34). Slide the spring washer (35) on the shaft and bushing assembly (36) from the end opposite the knob end.
- (2) Insert the four machine screws (33) in the four corner holes of the R25 mounting board (32).
  - (3) Secure variable resistor R25 (31) to the R25 mounting board (32) with the three machine screws (29) and hexagonal nuts (30).
  - (4) Insert the assembled shaft and bushing assembly (36), the collar (34), and spring washer (35) through the center hole of the assembled R25 mounting board (32) and variable resistor R25 (31).
  - (5) Slide the spring washer (28) on the shaft and bushing assembly (36). Slide the contact and collar assembly for R25 (27) on the shaft and bushing assembly (36). Position the contact and collar assembly for R25 (27) on the shaft so that the contact arm makes good mechanical contact with the windings of variable resistor R25 (31). Use the No. 10 Allen wrench and tighten the two setscrews in the side of the contact and collar assembly for R25 (27).
  - (6) Replace the four spacers (26) on the four machine screws (33).
  - (7) Secure variable resistor R24 (24) to the R24 mounting board (25) with the three machine screws (22) and hexagonal nuts (23).
  - (8) Replace the assembled R24 mounting board (25) and variable resistor R24 (24) on the four machine screws (33).
  - (9) Slide the spring washer (21) and the contact and collar assembly for R24 (20) on the shaft and bushing assembly (36). Position the contact and collar assembly for R24 (20) on the shaft so that the contact arm makes a good mechanical contact with the windings of variable resistor R24 (24). Use the No. 10 Allen wrench and tighten the two setscrews in the side of the contact and collar assembly R24 (20).
  - (10) Replace the two left side spacers (17), two right side spacers (19), and two mounting brackets (18) on the four machine screws (33).
  - (11) Secure variable resistor R21 (15) to the R21 mounting board (16) with the three machine screws (13) and hexagonal nuts (14).

- (12) Replace the assembled R21 mounting board (16) and variable resistor R21 (15) on the four machine screws (33).
- (13) Slide the spring washer (9) and the contact and collar assembly for R21 (8) on the shaft and bushing assembly (36). Position the contact and collar assembly for R21 (8) on the shaft so that the contact arm makes good mechanical contact with the windings of variable resistor R21 (15). Use the No. 10 Allen wrench and tighten the two setscrews in the side of the contact and collar assembly for R21 (8).
- (14) Replace the four plain washers (12), four lockwashers (11), and four hexagonal nuts (10) on the threaded ends of the four machine screws (33). Use a screwdriver to prevent the machine screws from turning as the four hexagonal nuts (10) are tightened.
- (15) Carefully place the Q and D-Q dial assembly in position against the back of the front panel (7). Check the alignment of the tapped holes in the R25 mounting board (32) with the matching holes in the front panel (7).
- (16) Secure the reassembled unit to the front panel (7) with the machine screws (6).
- (17) Replace bus wires A, B, C, D, and E (B, fig. 33.1) by reversing the disassembly procedure outlined in a(6) through (10) above. Be very careful when straightening bus wires so that each bus wire occupies the same relative position as it did before it was displaced and removed (par. 71b).
- (18) Mesh the thin plate located behind the Q and D-Q dial plate (A, 4, fig. 33.1) between the two plates on the fine adjustment knob assembly (5). Simultaneously, push the Q and D-Q dial plate (4) onto the shaft and bushing assembly (36) and the shaft of the fine adjustment knob assembly (5) into the front panel (7). Do not tighten the setscrews that secure the Q and D-Q dial plate.
- (19) Lay the bridge so that the front panel is facing upward. Aline the two spacers (3) with the tapped holes in the front panel (7) above the DETECTOR switch. Attach the dial alinement guide (2) with the two machine screws (1).
- (20) Use the notes made during disassembly of the reading of the Q and D-Q dial plate (a(4) above), and turn the dial so that its reading coincides with the reading noted

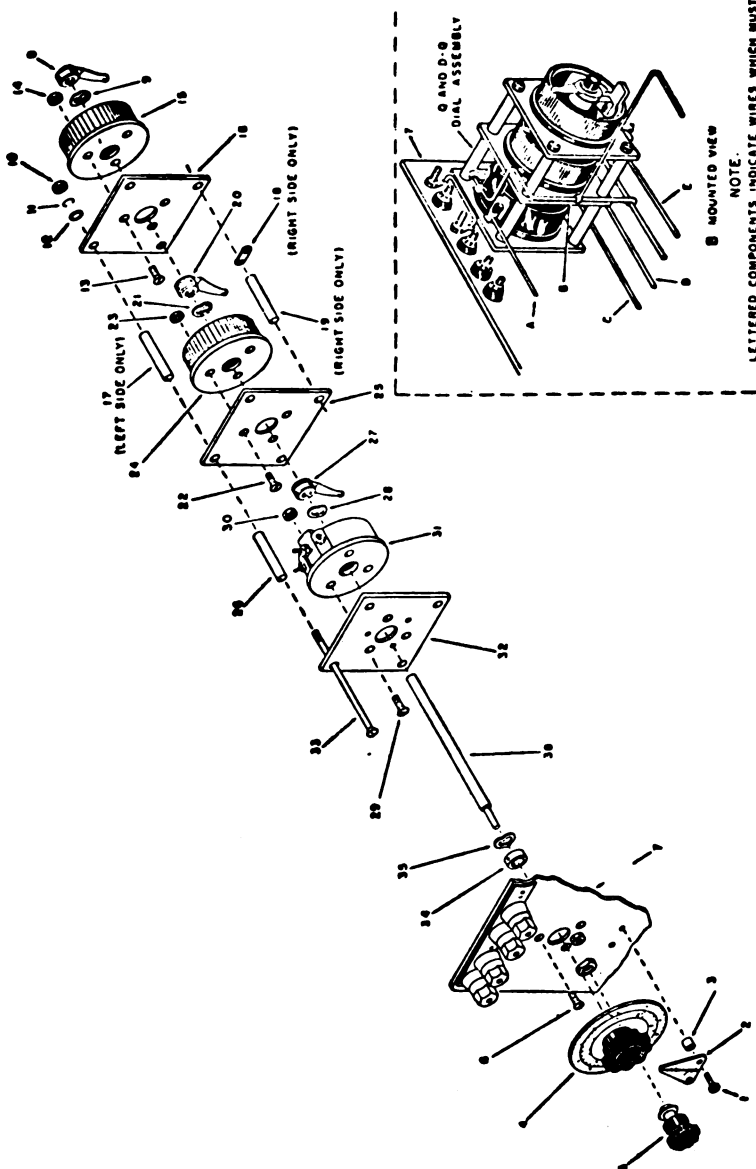

Figure 39.1. (Added) Q and D-Q assembly.

- 1 Machine screw, No. 6-32 by .500 inch long, brass, nickel plated, binding head
- 2 Dial alinement guide
- 3 Spacer, .250 inch OD by .148 inch ID by  $\frac{1}{4}$  inch long brass, nickel plated
- 4 Q and D-Q dial plate
- 5 Fine adjustment knob assembly
- 6 Machine screw, No. 8-32 by  $\frac{3}{8}$  inch long, brass, nickel plated, binding head
- 7 Front panel
- 8 Contact and collar assembly for R21
- 9 Spring washer,  $\frac{3}{8}$  inch OD by  $\frac{3}{8}$  inch ID
- 10 Hexagonal nut, No. 10-24
- 11 Lock washer, No. 10, split
- 12 Plain washer, .438 inch OD by .203 inch ID by .032 inch thick
- 13 Machine screw, No. 8-32 by  $\frac{1}{2}$  inch long, brass, nickel plated, flathead
- 14 Hexagonal nut, No. 8-32
- 15 Variable resistor R21
- 16 R21 mounting board
- 17 Left side spacer, .313 inch OD by .215 inch ID by  $1\frac{1}{16}$  inch long, aluminum
- 18 Mounting bracket
- 19 Right side spacer, .313 inch OD by .215 inch ID by  $1\frac{1}{8}$  inch long, aluminum
- 20 Contact and collar assembly for R24
- 21 Spring washer,  $\frac{3}{8}$  inch OD by  $\frac{3}{8}$  inch ID
- 22 Machine screw, No. 8-32 by  $\frac{1}{2}$  inch long, brass, nickel plated, flathead
- 23 Hexagonal nut, No. 8-32
- 24 Variable resistor R24
- 25 R24 mounting board
- 26 Spacer, .313 inch OD by .215 inch ID by  $1\frac{1}{16}$  inch long, aluminum
- 27 Contact and collar assembly for R25
- 28 Spring washer,  $\frac{3}{8}$  inch OD by  $\frac{3}{8}$  inch ID
- 29 Machine screw, No. 8-32 by  $\frac{1}{2}$  inch long, brass, nickel plated, flathead
- 30 Hexagonal nut, No. 8-32
- 31 Variable resistor R25
- 32 R25 mounting board
- 33 Machine screw, No. 10-24 by 4 inches long, steel, nickel plated, flathead
- 34 Collar
- 35 Spring washer,  $\frac{3}{8}$  inch OD by  $\frac{3}{8}$  inch ID
- 36 Shaft and bushing assembly

*Figure 33.1.—Continued.*

prior to disassembly. Use a No. 10 Allen wrench and tighten the two setscrews in the side of the Q and D-Q dial plate (4).

- (21) Use the notes describing the relative angular positioning of the contact and collar assemblies (8, 20, and 27) relative to each other, position each contact (8, 20, and 27) so that the proper angular relationship is restored. If repositioning of the contact and collar assemblies (8, 20, and 27) is necessary, loosen the two set screws in the side of the affected part with a No. 10 Allen wrench, and rotate the contact and collar assembly as necessary to effect the correct positioning. Follow this adjustment to retighten the setscrews.



- (22) Replace the black plastic mounting board for capacitor C2 by positioning it so that the holes are alined with the four mounting brackets. Replace the four machine screws, hexagonal nuts, lockwashers, and two wire clips associated with the replacement of the mounting board.
- (23) Replace capacitor C2 (par. 72b).
- (24) Check the calibration and recalibrate as necessary (par. 89, 90, and 91).
- (25) Replace the bridge chassis in the carrying case (par. 51b(11)).

## **88.2. Replacing LRC Dial Multiplier Switch S5, Circuit Selector Switch S6, and Switch S7**

(Added)

### **a. Removing Switches S5, S6 and S7 (figs. 30 and 32).**

- (1) Remove the bridge chassis from the carrying case (par. 51b(2)).
- (2) Remove capacitor C2 (par. 72a).
- (3) Remove the black plastic mounting board for capacitor C2 (par. 88.1a(3)).
- (4) Use the No. 10 Allen wrench and loosen the two setscrews in the side of the knob and pointer (A, 1, fig. 33.2). Remove the knob and pointer (1) from the inner shaft and bushing assembly (16).
- (5) Turn the circuit selector lever (2) to the extreme counterclockwise position and, with the No. 10 Allen wrench, loosen the two setscrews in the side of the circuit selector lever (2). The setscrews are located on the part of the circuit selector lever that protrudes behind the front panel (6). These setscrews must be completely removed and set aside. The circuit selector lever (2) is loose but cannot be removed until the calibrated indicator disk (4) is removed ((6), below).
- (6) Remove the two machine screws (3) that attach the calibrated indicator disk (4) to the front panel (6). Simultaneously, remove the calibrated indicator disk (4) from the panel and the circuit selector lever (2) from the outer shaft and bushing assembly (29).
- (7) Disconnect one end of bus wire A (B, fig. 33.2) from the rear of the C (high) binding post (fig. 6) by removing the hexagonal nut from the rear of the C (high) binding post. When the nut is removed, pull the binding post stud

forward until the bus wire and its soldering lug may be displaced slightly to one side. Replace the binding post and replace the hexagonal nut.

*Note.* Bus wires may be slightly bent or displaced for replacement purposes. If bending is necessary, be very careful. Extreme bends must be avoided. Tags should be attached to all bus wire lugs removed from terminals or binding post studs for identification purposes. On the tags, identify the terminal from which the individual lug was removed.

- (8) Unsolder the flexible *pigtail* lead located at the approximate center of the horizontal portion of bus wire A (B, fig. 33.2).
- (9) Disconnect one end of bus wire B from the binding posts on the front panel (6). Bus wire B is secured at the disconnect end by the C LO and LR LO binding posts. Remove the hexagonal nuts from these binding posts and pull the two binding post studs forward until bus wire B and its soldering lugs can be displaced slightly downward. Replace the binding posts and replace the hexagonal nuts. A black lead wire is soldered to the bus wire B soldering lug which is anchored to the LR LO binding post. Unsolder and tag this black lead.
- (10) Disconnect one end of bus wire C. Bus wire C may be unsoldered at either switchboard and resistor assembly (A, 15, fig. 33.2) or switchboard and resistor assembly (28).
- (11) Bus wire D (B, fig. 33.2) is terminated at the disconnect end by a soldering lug connected to a terminal stud on capacitor C2 and is disconnected when capacitor C2 is removed (a(2), above). Unsolder and disconnect the end of bus wire F at the point where the wire loops over bus wire E.
- (12) Unsolder and disconnect the end of bus wire E that terminates at the switchboard and resistor assembly (A, 15, fig. 33.2).
- (13) Disconnect one end of bus wire G (B, fig. 33.2) from the rear of the EXT. D-Q (high) binding post (fig. 6) by removing the hexagonal nut from this post and pulling the binding post stud forward until the bus wire and its soldering lug can be displaced slightly to one side. Replace the binding post and hexagonal nut.
- (14) Unsolder and disconnect bus wire H (B, fig. 33.2) at microswitch S7 (A, 34, fig. 33.2).

- (15) Unsolder and disconnect the ends of bus wires J, K, L, and M (B, fig. 33.2) which terminate at the switchboard and resistor assembly (A, 28, fig. 33.2).**

**Caution:** Be extremely careful when using a soldering iron in the vicinity of resistors R4 through R10, R22, and R23. These are precision resistors and prolonged exposure to the heat generated by the soldering iron may affect the accuracy of the parts.

- (16) Remove the three machine screws (5). Carefully remove the LRC dial multiplier, circuit selector switch, and microswitch S7 assembly from the rear of the front panel (6). Be sure all bus wires and associated lugs have been displaced sufficiently to prevent damage.**
- (17) Use a screwdriver to prevent the machine screws (35) from turning, and remove the four hexagonal nuts (7), lockwashers (8), and plain washers (9) from the machine screws (35).**
- (18) Unsolder one end of flexible pigtail lead N (B, fig. 33.2) at the contact ring assembly for S5 (A, 13, fig. 33.2). Use the No. 10 Allen wrench to loosen the two setscrews in the side of the contact ring assembly for S5 (13). Remove the assembled switchboard and resistor assembly (15) and contact ring assembly for S5 (13) from the four machine screws (35).**
- (19) Disassemble the contact ring assembly for S5 (13) from the switchboard and resistor assembly (15) by removing the two machine screws (12), hexagonal nuts (10), and lockwashers (11). The lockwasher (14) will fall free when the assemblies are detached.**
- (20) Remove the inner shaft and bushing assembly (16) from the outer shaft and bushing assembly (29) and set it aside.**
- (21) Use the No. 10 Allen wrench to loosen the two setscrews in the side of the contact and bushing assembly (17) and remove it from the outer shaft and bushing assembly (29).**
- (22) Remove the two spacers (18), mounting brackets (19), and spacers (20) from the two left side machine screws (35) and two spacers (21) from the two right side machine screws (35).**
- (23) Use the No. 10 Allen wrench and loosen the two setscrews in the side of the contact and bushing assembly (22); remove it from the outer shaft and bushing assembly (29).**

- (24) Use the No. 10 Allen wrench and loosen the two setscrews in the side of the contact ring assembly (26). Remove the outer shaft and bushing assembly (29) and set it aside. Remove the assembled switchboard and resistor assembly (28) and contact ring assembly (26) from the four machine screws (35).
- (25) Unsolder one end of the flexible lead (37) at the contact ring assembly (26).
- (26) Disassemble the contact ring assembly (26) from the switchboard and resistor assembly (28) by removing the two machine screws (25), hexagonal nuts (23), and lockwashers (24). The lockwasher (27) will fall free when the contact ring assembly (26) is removed.
- (27) Remove the four spacers (30) from the four machine screws (35). Remove the four machine screws (35) from the mounting plate (36).
- (28) Remove microswitch S7 (34) from the mounting plate (36) by unscrewing and removing the two machine screws (33), hexagonal nuts (31), and lockwashers (32).

**b. Reassembling Switches S5, S6, and S7.**

- (1) Attach the microswitch (A, 34, fig. 33.2) to the mounting plate (36) with the two machine screws (33), hexagonal nuts (31), and lockwashers (32).
- (2) Insert the four machine screws (35) in the four corner holes of the mounting plate (36) and replace the four spacers (30) on the threaded ends of the four machine screws (35).
- (3) Mount the contact ring assembly (26) and lockwasher (27) on the switchboard and resistor assembly (28). Secure them with the two machine screws (25), hexagonal nuts (23), and lockwashers (24). Resolder the end of the flexible lead (37) to the contact ring assembly (26).
- (4) Replace the assembled switchboard and resistor assembly (28) and contact ring assembly (26) on the four machine screws (35) adjacent to the four spacers (30).
- (5) Insert the outer shaft and bushing assembly (29) through the center openings of the contact ring assembly (26) and switchboard and resistor assembly (28). Adjust the outer shaft and bushing assembly (29) until approximately  $1\frac{1}{4}$  inches is measured between the forward end of the outer shaft and bushing assembly (29) and the forward face of the contact ring assembly (26).

- (6) Use the No. 10 Allen wrench to tighten the two setscrews in the side of the contact ring assembly (26).
- (7) Slide the contact and bushing assembly (22) on the outer shaft and bushing assembly (29). Be sure that the wiper arm of the contact and bushing assembly (22) maintains sufficient pressure against the switch contacts on the switchboard and resistor assembly (28). Use a No. 10 Allen wrench to tighten the two setscrews in the side of the contact and bushing assembly (22).
- (8) Replace the two spacers (21) on the two right side machine screws (35) and the two spacers (20), mounting brackets (19), and spacers (18) on the two left side machine screws (35).
- (9) Slide the contact and bushing assembly (17) on the outer shaft and bushing assembly (29). Do not tighten the setscrews in the side of the bushing.
- (10) Replace the contact ring assembly (13), and lockwasher (14) on the switchboard and resistor assembly (15) and secure it with the two machine screws (12), lockwashers (11), and hexagonal nuts (10).
- (11) Insert the inner shaft and bushing assembly (16) into the outer shaft and bushing assembly (29) through the contact and bushing assembly (17).
- (12) Carefully replace the assembled switchboard and resistor assembly (15) and contact ring assembly (13) on the four machine screws (35) so that the inner diameter of the contact ring assembly (13) rests on the large diameter part of the inner shaft and bushing assembly (16).
- (13) Replace the four plain washers (9), lockwashers (8), and hexagonal nuts (7) on the threaded ends of the four machine screws (35). A screwdriver may be used to keep the machine screws from turning as the four hexagonal nuts (7) are tightened.
- (14) Position the contact and bushing assembly (17) on the outer shaft and bushing assembly (29) so that the wiper arm maintains sufficient pressure against the switch contacts on the switchboard and resistor assembly (15). Use the No. 10 Allen wrench to tighten the two setscrews in the side of the contact and bushing assembly (17).
- (15) Use the No. 10 Allen wrench and tighten the two setscrews in the side of the contact ring assembly (13).
- (16) Place the LRC Dial multiplier, circuit selector switch and microswitch S7 assembly in position against the back of the front panel (16). Aline the tapped holes in

the mounting plate (36) with the matching holes in the front panel (6) and replace the three machine screws (5).

- (17) Carefully work the bushing end of the circuit selector lever (2) through from the front of the calibrated indicator disk (4). Carefully align the raised detent of the circuit selector lever (2) with the notched cutout in the front panel and replace the circuit selector lever (2) on the outer shaft and bushing assembly (29).
- (18) Replace the two setscrews in the bushing of the circuit selector lever (2) and tighten them with the No. 10 Allen wrench.
- (19) Position the calibrated indicator disk (4) against the front panel (6) so that the two mounting holes of the calibrated indicator disk (4) are aligned with the tapped holes in the front panel (6). Replace the two machine screws (3).
- (20) Replace the knob and pointer (1) on the inner shaft and bushing assembly (16) and, using a No. 10 Allen wrench, tighten the two setscrews in the side of the knob and pointer (1).
- (21) Resolder the ends of bus wires J, K, L, and M (B, fig. 33.2) to their respective terminals on the switchboard and resistor assembly (A, 28, fig. 33.2).

*Caution:* Be extremely careful when using a soldering iron in the vicinity of resistors R4 through R10, R22, and R23. These are precision resistors and prolonged exposure to the heat generated by the soldering iron may affect the accuracy of the parts.

- (22) Connect and solder the end of bus wire H (B, fig. 33.2) to microswitch S7 (A, 34, fig. 33.2).
- (23) Reconnect the end of bus wire G (B, fig. 33.2) to the EXT. D-Q (high) binding post (fig. 6) by removing the hexagonal nut from the rear of the post and pulling the binding post stud forward until the bus wire and attached soldering lug can be maneuvered into alignment with the binding post stud. Insert the binding post stud into the soldering lug. Replace the hexagonal nut and tighten it.
- (24) Reconnect and solder the end of bus wire E to its terminal on the switchboard and resistor assembly (A, 15, fig. 33.2). Reconnect and solder bus wire F (B, fig. 33.2) to bus wire E at the point shown in B, figure 33.2.

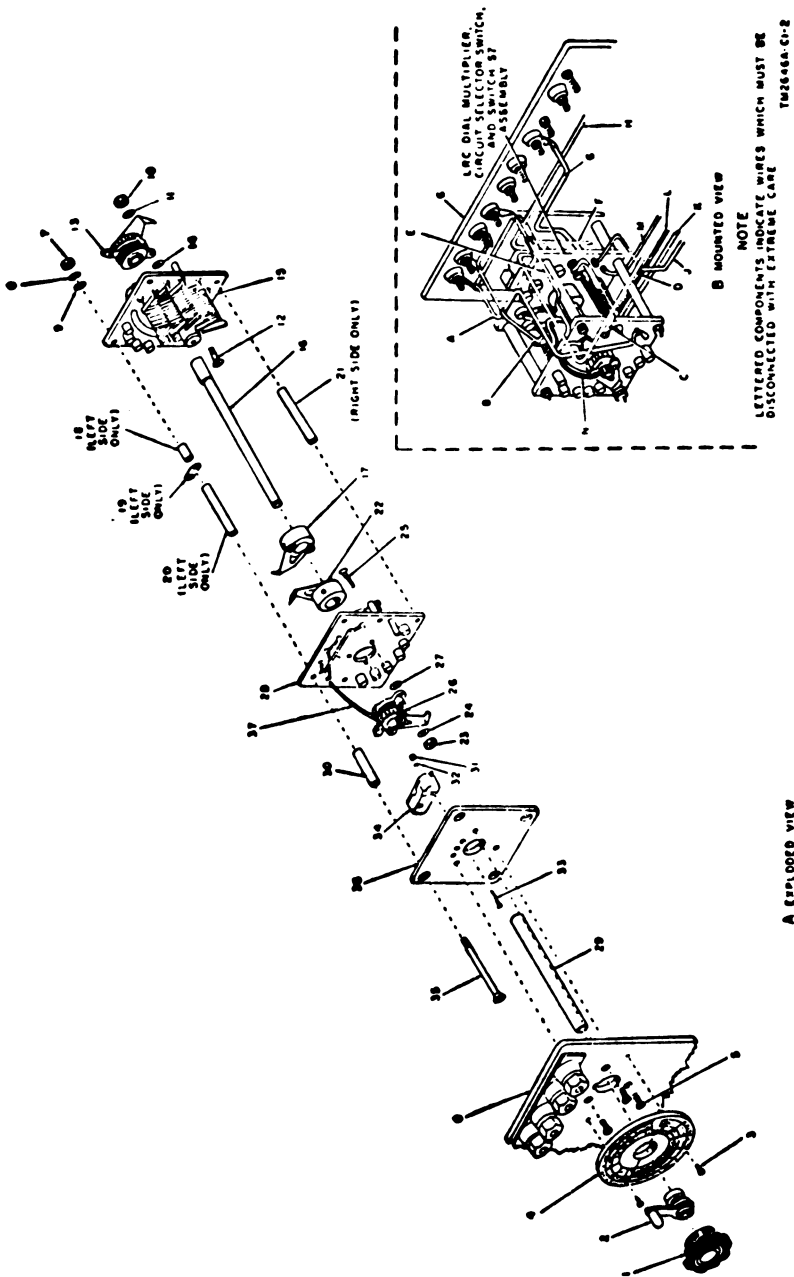

Figure 33.f. (Added) LRC Dial Multiplier, circuit selector switch, and microswitch S7 assembly.

- 1 Knob and pointer
- 2 Circuit selector lever
- 3 Machine screw, No. 4-40 by  $\frac{3}{32}$  inch long, brass, nickel plated, binding head
- 4 Calibrated indicator disk
- 5 Machine screw, No. 8-32 by  $\frac{3}{8}$  inch long, brass, nickel plated, flathead
- 6 Front panel
- 7 Hexagonal nut, No. 10-24
- 8 Lock washer, No. 10, split
- 9 Plain washer, .438 inch OD by .203 inch ID by .032 inch thick
- 10 Hexagonal nut, No. 6-32
- 11 Lock washer, No. 6, split
- 12 Machine screw, No. 6-32 by  $\frac{1}{2}$  inch long, brass, cadmium plated, flathead
- 13 Contact ring assembly for S5
- 14 Lock washer, No. 6, internal tooth
- 15 Switchboard and resistor assembly (part of S5 and S6 and includes R4-R10)
- 16 Inner shaft and bushing assembly
- 17 Contact and bushing assembly (part of S6)
- 18 Spacer, .313 inch OD by .215 inch ID by  $\frac{1}{16}$  inches long
- 19 Mounting bracket
- 20 Spacer, .313 inch OD by .215 inch ID by  $1\frac{1}{16}$  inches long, aluminum
- 21 Spacer, .313 inch OD by .215 inch ID by  $2\frac{1}{16}$  inches long, aluminum
- 22 Contact and bushing assembly (part of S6)
- 23 Hexagonal nut, No. 6-32
- 24 Lockwasher, No. 6, split
- 25 Machine screw, No. 6-32 by  $\frac{1}{2}$  inch long, brass, cadmium plated, flathead
- 26 Contact ring assembly (part of S5)
- 27 Lockwasher, No. 6, internal tooth
- 28 Switchboard and resistor assembly (part of S6 and includes R22 and R23)
- 29 Outer shaft and bushing assembly
- 30 Spacer, .313 inch OD by .215 inch ID by  $1\frac{1}{16}$  inch long, aluminum
- 31 Hexagonal nut, No. 2-56
- 32 Lockwasher, No. 2, split
- 33 Machine screw, No. 2-56 by  $\frac{3}{4}$  inch long, brass, nickel plated, flathead
- 34 Microswitch (S7)
- 35 Machine screw, No. 10-24 by  $4\frac{1}{2}$  inches long, steel, nickel plated, flathead
- 36 Mounting plate
- 37 Flexible lead

Figure 33.2.—Continued.

- 
- (25) Reconnect and solder the disconnected end of bus wire C (B, fig. 33.2) depending on the point of disconnection (a(10) above).
  - (26) Remove the hexagonal nuts from C LO and LR LO binding posts and pull the binding post studs forward. Aline the two soldering lugs attached to bus wire B, with their respective studs. Replace the studs so that they pass through the soldering lugs. Resolder the black lead wire to the bus wire B soldering lug that is attached to the LR LO binding post. Replace and tighten the two hexagonal nuts on the binding posts.
  - (27) Resolder the flexible *pigtail* lead that connects to the approximate center of the horizontal portion of bus wire A.



- (28) Reconnect the end of bus wire A to the C (high) binding post (fig. 6) by removing the hexagonal nut from the rear of this post. Pull the binding post stud forward until the bus wire and soldering lug can be maneuvered into alignment with the binding post stud. Insert the stud through the soldering lug. Replace and tighten the hexagonal nut on the binding post.
- (29) Replace and solder the end of flexible lead N to the contact ring assembly (A, 13, fig. 33.2).
- (30) Replace the black plastic mounting board for capacitor C2 by reassembling the four machine screws, hexagonal nuts, and lockwashers that secure the mounting board to the four capacitor mounting brackets.
- (31) Replace capacitor C2 (par. 72b).
- (32) Replace the bridge chassis in the carrying case (par. 51b(11)).

### **88.3. Replacing LRC Dial Variable Resistor R36**

(Added)

#### *a. Removing Variable Resistor R36.*

- (1) Remove the bridge chassis from the carrying case (par. 51b(2)).
- (2) Disconnect one end of bus wire A (B, fig. 33.3) from variable resistor R36 (A, 16, fig. 33.3) by removing the terminal mounting nut from the left-hand terminal and lifting the bus wire and its attached lug from the terminal.
- (3) Disconnect one end of bus wire B (B, fig. 33.3) by removing the two terminal retaining nuts from the middle and right-hand terminals on variable resistor R36 (A, 16, fig. 33.3) and lifting the bus wire and two attached soldering lugs from the terminals. Note the position of the two soldering lugs on bus wire B (B, fig. 33.3) then unsolder and remove the two lugs from the bus wire. Remove all the excess solder.
- (4) Note the dial and pointer settings of the inner dial and knob assembly (A, 4, fig. 33.3) (par. 71c). Loosen the setscrews in the side of the contact and collar assembly for R36 (9). Remove the contact and collar assembly for R36 (9) and spring washer (10) from the end of the bushing and shaft assembly (20).

- (5) Remove the four hexagonal nuts (11), four lockwashers (12), and plain washers (13) from the threaded ends of the four machine screws (42).
- (6) Carefully remove the assembled R36 mounting board (17) and variable resistor R36 (16) from the four machine screws (42). Removal of this assembly will require straightening of the 90° bends in bus wire B (B, fig. 33.3). Do not straighten the bends beyond the point necessary to facilitate passage of bus wire B through hole C as the assembly is removed.  
*Caution:* When removing variable resistor R36 be careful to avoid striking the windings of variable resistor R36 (A, 16, fig. 33.3) with the end of the oscillator filter assembly Z3 attaching screw which protrudes through the chassis.
- (7) Remove variable resistor R36 (16) from the R36 mounting board (17) by removing the three machine screws (14) and hexagonal nuts (15).

*b. Replacing Variable Resistor R36.*

- (1) Replace variable resistor R36 (A, 16, fig. 33.3) on the R36 mounting board (17); use the three machine screws (14) and hexagonal nuts (15).
- (2) Carefully replace the assembled mounting board (17) and variable resistor R36 (16) on the four machine screws (42). Simultaneously pass bus wire B (B, fig. 33.3) through hole C in the R36 mounting board (A, 17, fig. 33.3). Reform bus wire B (B, fig. 33.3) to its original shape (a(6), above).
- (3) Replace and tighten the four hexagonal nuts (11), lockwashers (12), and plain washers (13) on the threaded ends of the four machine screws (42).
- (4) Set the LRC dial on the front panel to precisely 0.00. Place the contact and collar assembly (9) and spring washer (10) on the bushing and shaft assembly (20). Carefully position the contact on the contact and collar assembly (9) on the first turn of resistance wire next to the terminal mounting screw for bus wire A (B, fig. 33.3) on variable resistor R36 (A, 16, fig. 33.3). Tighten the setscrews in the side of the contact and collar assembly (A, 9, fig. 33.3).
- (5) Resolder the two soldering lugs to bus wire B (B, fig. 33.3) in the position previously noted (a(3), above). Replace the two soldering lugs on the middle and right-

- hand terminals of variable resistor R36 (A, 16, fig. 33.3) and replace and tighten the two terminal retaining nuts.
- (6) Reconnect the end of bus wire A (B, fig. 33.3) to the remaining terminal on variable resistor R36. Replace and tighten the terminal retaining nut.
  - (7) Replace the bridge chassis in the carrying case (par. 51b(11)).

#### **88.4. Replacing LRC Dial Switches S4 and S8**

(fig. 32)

(Added)

##### *a. Replacing Switches S4 and S8.*

- (1) Remove the bridge chassis from the carrying case (par. 51b(2)).
- (2) Remove LRC dial multiplier switch S5, circuit selector switch S6, and switch S7 assembly (pars. 88.2a(2)–(16)).
- (3) Set the LRC dial at precisely 0.00 and then note the following:
  - (a) The exact position of the wiper of the contact and collar assembly for R36 (A, 9, fig. 33.3) on the windings of variable resistor R36 (16).
  - (b) The position of the wiper of the contact ring assembly for S8 (27) on the contacts of the switchboard and resistor assembly (30).
  - (c) The position of the wiper of the contact ring assembly for S4 (38) on the contacts of the switchboard and resistor assembly (40).
- (4) Detach the dial alignment guide (2) by removing the two machine screws (1) and spacers (3).
- (5) Use the No. 8 Allen wrench to loosen the two setscrews in the side of the inner dial and knob assembly (4) and remove it from the bushing and shaft assembly (20).
- (6) Use the No. 10 Allen wrench to loosen the two setscrews in the side of the contact ring assembly for S8 (27). Withdraw the middle dial and bushing assembly (5) from the front panel (8).
- (7) Use the No. 10 Allen wrench to loosen the two setscrews in the side of the contact ring assembly for S4 (38). Withdraw the outer LRC dial assembly (6) from the front panel (8).

- (8) Unsolder the end of red lead D (B, fig. 33.3) and bus wire E at their junction terminal on switchboard and resistor assembly (A, 40, fig. 33.3).
  - (9) Remove LRC dial variable resistor R36 (par. 88.3a(2)-(6)).
  - (10) Unsolder bus wire B (B, fig. 33.3) at solder junction H. Remove all solder from bus wire B and pull the bus wire from the assembly through holes F and G.
  - (11) Remove the three machine screws (A, 7, fig. 33.3) and pull the assembly consisting of assembled switches S4 and S8 from the front panel (8).
  - (12) Remove the four spacers (21) from the four machine screws (42).
  - (13) Use the No. 10 Allen wrench to loosen the two setscrews in the side of the collar (18); remove it and the spring washer (19) from the bushing and shaft assembly (20).
  - (14) Unsolder bus wire I (B, fig. 33.3) at its soldered terminal on the rear of switchboard and resistor assembly (A, 30, fig. 33.3).
  - (15) Remove the assembled switchboard and resistor assembly (30) and the contact ring assembly for S8 (27) from the four machine screws (42).
  - (16) Detach the contact ring assembly for S8 (27) from the switchboard and resistor assembly (30) by removing the machine screws (24 and 26) and hexagonal nuts (22 and 25). The lockwashers (23, 29, and 44) will fall free. Remove the insulator (28) from the contact ring assembly for S8 (27).
  - (17) Remove the four spacers (31) from the four machine screws (42).
  - (18) Remove the assembled switchboard and resistor assembly (40) and the contact ring assembly for S4 (38) from the four machine screws (42).
  - (19) Detach the contact ring assembly for S4 (38) from the switchboard and resistor assembly (40) by removing the machine screws (34 and 37), nuts (35 and 32), and lockwashers (36, 33, and 39).
  - (20) Remove the four spacers (41) and four machine screws (42) from the switch mounting plate (43).
- b. Reassembling Switches S4 and S8.*
- (1) Replace the four machine screws (A, 42, fig. 33.3) in the switch mounting plate (43). Replace the four spacers (41) on the four machine screws (42).

- (2) Attach the contact ring assembly for S4 (38) to the switchboard and resistor assembly (40) with the machine screws (34 and 37), nuts (35 and 32), lockwashers (36, 33 and 39).
- (3) Replace the assembled switchboard and resistor assembly (40) and the contact ring assembly for S4 (38) on the four machine screws (42).
- (4) Replace the four spacers (31) on the four machine screws (42).
- (5) Attach the contact ring assembly for S8 (27) to the switchboard and resistor assembly (30); use the machine screws (24 and 26), hexagonal nuts (22 and 25), and lockwashers (23, 29, and 44). Insert the insulator (28) into the contact ring assembly for S8 (27).
- (6) Replace the assembled switchboard and resistor assembly (30) and the contact ring assembly for S8 (27) on the four machine screws (42).
- (7) Resolder bus wire I (B, fig. 33.3) to its terminal on the rear of the switchboard and resistor assembly (A, 30, fig. 33.3).
- (8) Replace the bushing and shaft assembly (20) and replace the spring washer (19) and the collar (18) on the bushing and shaft assembly (20). Tighten the two set-screws in the side of the collar (18) with the No. 10 Allen wrench.
- (9) Replace the four spacers (21) on the four machine screws (42).
- (10) Attach assembled switches S4 and S8 to the front panel (8) with the three machine screws (7).
- (11) Insert bus wire B (B, fig. 33.3) through holes F and G and solder bus wire B to solder junction H.
- (12) Replace LRC dial variable resistor R36 (pars. 88.3a (2)-(6)).
- (13) Resolder the loose end of red lead D (B, fig. 33.3) and bus wire E at their junction terminal on switchboard and resistor assembly (A, 40, fig. 33.3).
- (14) Insert the outer LRC dial assembly (6) through the front panel (8) and into the contact ring assembly for S4 (38). Use the No. 10 Allen wrench to tighten the two set-screws in the contact ring assembly for S4 (38) when the calibrated dial and wiper arm are in their previously noted positions (*a*(3) (*a*) above).

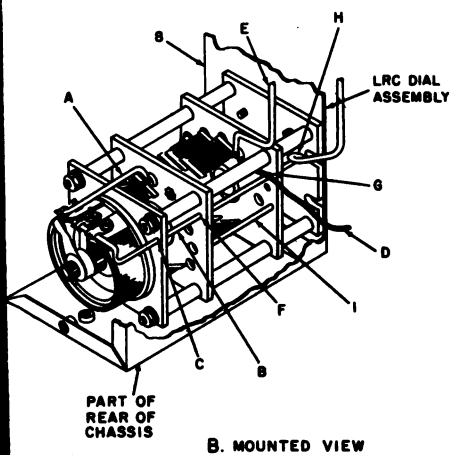
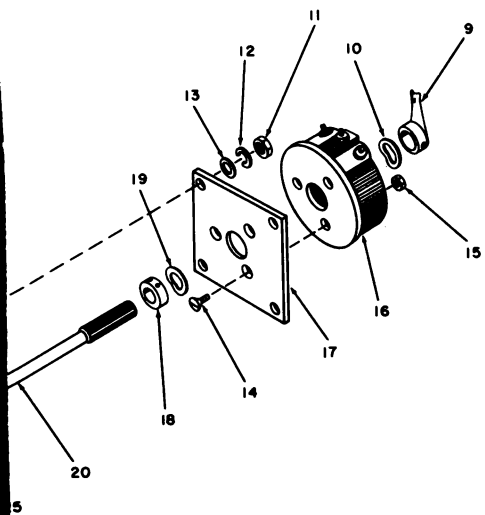

**NOTE:**  
WIRES INDICATED BY LETTERS MUST  
BE DISCONNECTED WITH EXTREME CARE.

TM2646A-CI-3



J2  
S  
J3

**NOTES:**

1. UNLESS OTHERWISE SHOWN, RESISTANCES ARE IN OHMS, CAPACITANCES ARE IN UUF.
2.  INDICATES EQUIPMENT MARKING.
3. SWITCH S5 IS VIEWED FROM REAR.
4. SECTION 1 OF SWITCH S6 IS NEAREST TO CONTROL KNOB.
5. SWITCHES S4 AND S6 AND VARIABLE RESISTOR R36 COMPRISE THE LRC DIAL.
6. DETECTOR SWITCH S1 AND GENERATOR SWITCH S12 ARE VIEWED FROM REAR. SECTION 1 OF SWITCH S12 IS NEAREST TO CONTROL KNOB.
7. DETECTOR SWITCH IS SHOWN IN METER POSITION.
8. GENERATOR SWITCH IS SHOWN IN DC HI POSITION.
9. CONTACTS MADE IN EACH POSITION OF SWITCH S5 AS FOLLOWS.

SWITCH POSITION			CONTACT
L	R	C	
0.1mh	0.1 $\Omega$	100uf	1
1mh	1 $\Omega$	1uf	2
10mh	10 $\Omega$	1uf	3
100mh	100 $\Omega$	0.1uf	4
1h	1k $\Omega$	.01uf	5
10h	10k $\Omega$	.001uf	6
100h	100 $\Omega$	100uf	7

10. SWITCH S7 CLOSES WHEN S6 IS IN THE L AND D-OXI POSITION.
11. DASHED LINE INDICATES JUMPER PLACED BETWEEN EXT. D-O BINDING POSTS, WHEN EXTERNAL DECADE RESISTOR IS NOT CONNECTED.

BE





- 1 Machine screw, No. 6-32 by .750 inch long, brass, nickel plated, binding head
- 2 Dial alinement guide
- 3 Spacer, .250 inch OD by .148 inch ID by  $\frac{1}{16}$  inch long, brass, nickel plated
- 4 Inner dial and knob assembly
- 5 Middle dial and bushing assembly
- 6 Outer LRC dial assembly
- 7 Machine screw, No. 8-32 by  $\frac{1}{2}$  inch long, brass, nickel plated, binding head
- 8 Front panel
- 9 Contact and collar assembly for R36
- 10 Spring washer,  $\frac{3}{8}$  inch OD by  $\frac{1}{2}$  inch ID
- 11 Hexagonal nut, No. 10-24
- 12 Lockwasher, No. 10, split
- 13 Plain washer, .438 inch OD by .203 inch ID by .032 inch thick
- 14 Machine screw, No. 8-32 by  $\frac{1}{2}$  inch long, brass, nickel plated, flathead
- 15 Hexagonal nut, No. 8-32
- 16 Variable resistor R36
- 17 R36 mounting board
- 18 Collar
- 19 Spring washer,  $\frac{3}{8}$  inch OD by  $\frac{1}{2}$  inch ID
- 20 Bushing and shaft assembly
- 21 Spacer, .313 inch OD by .215 inch ID by  $1\frac{1}{2}$  inch long, aluminum
- 22 Hexagonal nut, No. 6-32
- 23 Lockwasher, No. 6, split
- 24 Machine screw, No. 6-32 by  $\frac{1}{2}$  inch long, brass, cadmium plated, flathead
- 25 Hexagonal nut, No. 6-32
- 26 Machine screw, No. 6-32 by  $\frac{1}{2}$  inch long, brass, cadmium plated, flathead
- 27 Contact ring assembly for S8
- 28 Insulator, .500 inch OD by .312 inch ID by .750 inch long, black, phenolic
- 29 Lockwasher, No. 6, internal tooth
- 30 Switchboard and resistor assembly (part of S8 and includes R27-R35)
- 31 Spacer, .313 inch OD by .215 inch ID by  $2\frac{1}{4}$  inches long, aluminum
- 32 Hexagonal nut, No. 6-32
- 33 Lockwasher, No. 6, split
- 34 Machine screw, No. 6-32 by  $\frac{1}{2}$  inch long, brass, cadmium plated, flathead
- 35 Hexagonal nut, No. 6-32
- 36 Lockwasher, No. 6, split
- 37 Machine screw, No. 6-32 by  $\frac{1}{2}$  inch long, brass, cadmium plated, flathead
- 38 Contact ring assembly for S4
- 39 Lockwasher, No. 6, internal tooth
- 40 Switchboard and resistor assembly (part of S4 and includes R11-R20)
- 41 Spacer, .313 inch OD by .215 inch ID by  $1\frac{1}{2}$  inches long, aluminum
- 42 Machine screw, No. 10-24 by  $5\frac{1}{4}$  inches long, brass, nickel plated, flathead
- 43 Switch mounting plate
- 44 Lockwasher, No. 6, split

Figure 33.3.—Continued.

- (15) Insert the middle dial and bushing assembly (5) through the front panel (8) and into the contact ring assembly for S8 (27). Use the No. 10 Allen wrench to tighten the two setscrews in the contact ring assembly for S8 (27) when the calibrated dial and wiper arm are in their previously noted positions (a (3) (b) above).
- (16) Replace the inner dial and knob assembly (4) on the bushing and shaft assembly (20). Use the No. 8 Allen wrench to tighten the two setscrews in the side of the inner dial and knob assembly (4) when the calibrated dial and wiper arm are in their previously noted positions (a (3) (c) above).

- (17) Attach the dial alinement guide (2) with the two machine screws (1) and spacers (3).
- (18) Replace the LRC dial multiplier switch S5, circuit selector switch S6, and switch S7 (par. 88.2b(16)-(31)).
- (19) Replace the bridge chassis in its carrying case (par. 51b(11)).

[AG 413.6 (5 Nov 56)]

By Order of *Wilber M. Brucker*, Secretary of the Army:

**MAXWELL D. TAYLOR**,  
*General, United States Army,*  
*Chief of Staff.*

Official:

**JOHN A. KLEIN**,  
*Major General, United States Army,*  
*The Adjutant General.*

Distribution:

*Active Army:*

CNGB (1)  
 ASA (3)  
 Tec Svc, DA (1) except  
   CSIGO (30)  
 Tec Svc Bd (1)  
 Hq CONARC (5)  
 CONARC Bd (Incl ea Test  
   Sec) (1)  
 Army AA Comd (2)  
 OS Maj Comd (5)  
 OS Base Comd (5)  
 Log Comd (5)  
 MDW (1)  
 Armies (5)  
 Corps (2)  
 Ft & Cp (2)  
 Sp Wpn Comd (2)  
 Army Cml Cen (4)  
 Gen & Br Svc Sch (5)  
   except Sig Sch (25)  
 Gen Depots (2) except  
   Atlanta Gen Depot (None)  
 Sig Sec, Gen Depots (10)  
 Sig Depots (17)

US Army Tng Cen (2)  
 POE (OS) (2)  
 Trans Terminal Comd (2)  
 Army Terminals (2)  
 OS Sup Agencies (2)  
 Army Elet PG (1)  
 Sig Fld Maint Shops (3)  
 Sig Lab (5)  
 ACS (3)  
 Mil Dist (1)  
 Units org under fol TOE:  
   11-7C, Sig Co, Inf Div (2)  
   11-16C, Hq & Hq Co, Sig Bn,  
     Corps or Abn Corps (2)  
   11-57C, Armd Sig Co (2)  
   11-127R, Sig Rep Co (2)  
   11-128C, Sig Depot Co (2)  
   11-500R, Sig Svc Org (2)  
   11-557C, Abn Sig Co (2)  
   11-587R, Sig Base Maint Co (2)  
   11-592R, Hq & Hq Co, Sig Base  
     Depot (2)  
   11-597R, Sig Base Depot Co (2)

NG: State AG (6); units—same as Active Army except allowance is one copy to each unit.

USAR: None.

For explanation of abbreviations used, see SR 320-50-1.

## **W A R N I N G**

### **DANGEROUS VOLTAGES EXIST IN THIS EQUIPMENT**

Be careful when working on the 250-volt plate connections of electron tubes V1, V2, and V3 and the 115-volt ac line connections. Discharge all high-voltage capacitors by short-circuiting them after the power has been turned off, before making any test connections or working inside the equipment.

**DON'T TAKE CHANCES!**



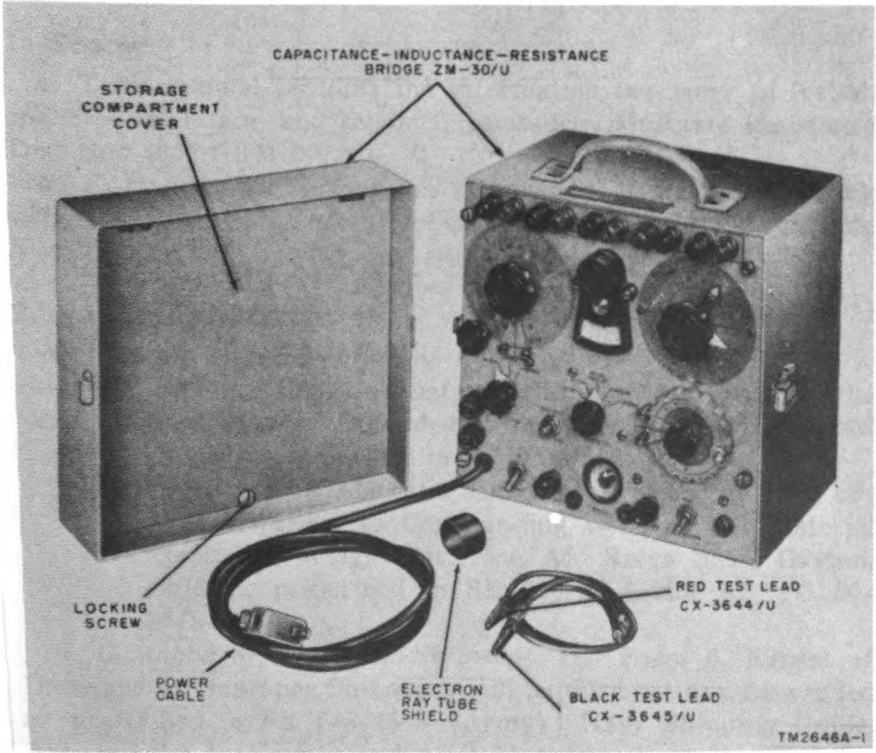

**Figure 1. Major components of Capacitance-Inductance-Resistance Test Set AN/URM-90.**



# CHAPTER 1

## INTRODUCTION

---

### Section I. GENERAL

#### 1. Scope

*a.* This manual contains the information necessary to install, operate, maintain, and repair Capacitance-Inductance-Resistance Test Set AN URM-90.

*b.* Forward all comments on this manual to the Commanding Officer, The Signal Corps Publications Agency, Fort Monmouth, New Jersey.

#### 2. Forms and Records

*a. Unsatisfactory Equipment Reports.*

- (1) DA Form 468, Unsatisfactory Equipment Report, will be filled out and forwarded to the Office of the Chief Signal Officer, as prescribed in SR 700-45-5.
- (2) DD Form 535, Unsatisfactory Report, will be filled out and forwarded to Commanding General, Air Materiel Command, Wright-Patterson Air Force Base, Dayton, Ohio, as prescribed in SR 700-45-5 and AF TO 00-35D-54.

*b. Damaged or Improper Shipment.* DD Form 6, Report of Damaged or Improper Shipment, will be filled out and forwarded as prescribed in SR 745-45-5 (Army); Navy Shipping Guide, Article 1850-4 (Navy); and AFR 71-4 (Air Force).

*c. Preventive Maintenance Forms.*

- (1) DA Form 11-238, Operator First Echelon Maintenance Check List for Signal Corps Equipment (Radio Communication, Direction Finding, Carrier, Radar), will be prepared in accordance with instructions on the back of the form (fig. 13).
- (2) DA Form 11-239, Second and Third Echelon Maintenance Check List for Signal Corps Equipment (Radio Communication, Direction Finding, Carrier, Radar), will be prepared in accordance with instructions on the back of the form (fig. 14).



## Section II. DESCRIPTION AND DATA

### 3. Purpose and Use

Capacitance-Inductance-Resistance Test Set AN/URM-90 is a self-contained instrument used in electrical and electronic work where the values and characteristics of resistors, capacitors, and inductors must be accurately measured. The test set is used to make direct measurements of resistance, capacitance, inductance, dissipation factors of capacitors, and the storage factors of inductors.

### 4. Technical Characteristics

Input voltage .....	115 volts ac.
Input frequency .....	50 to 1,000 cps.
Phase .....	Single.
Power consumed .....	18 watts.
Fuse rating .....	3 amperes.
Tubes (number and function)	One 12AT7 oscillator-amplifier (V1). One 6U5 electron ray tube (V2). One 12AX7 amplifier (V3).
Internal oscillator frequency	1,000, $\pm 10$ cps.
Operating frequency range..	100 to 10,000 cps.
Internal detectors:	
Ac measurements .....	Type 6U5 electron ray tube (V2).
Dc measurements .....	Galvanometer.
Galvanometer data:	
Range .....	7.5 to 0 to 7.5 microamperes.
Accuracy (full-scale) .....	20%.
Internal resistance .....	1,000 ohms.
Ranges:	
Resistance .....	0.1 milliohm to 11 megohms.
Capacitance .....	0.1 uuf to 1,100 uf.
Inductance .....	0.1 microhenry to 1,100 henrys.
Dissipation factor (R/X, or D) .....	0.001 to 1.05.
Storage factor (X/R, or Q) .....	0.02 to 1,000.
Accuracy: (effective only for normal conditions of operation, heat, and humidity).	
Resistance .....	$\pm (.15\% + 1 \text{ division on the LRC inner dial}).$

- Capacitance .....  $\pm (5\% + 1 \text{ division on the LRC inner dial})$ .
- Inductance .....  $\pm (1\% + 1 \text{ division on the LRC inner dial})$ .
- Dissipation factor (D) ... Expressed in terms of its reciprocal Q,  $\pm (5\% + .0025)$  for capacitance values greater than .01 uf.
- Storage factor ..... Expressed in terms of its reciprocal D,  $\pm (5\% + .0025)$ .

## 5. Common Names

The following common names have been assigned to nomenclatured items to simplify test material.

<i>Nomenclature</i>	<i>Common name</i>
Capacitance-Inductance-Resistance Test Set AN/URM-90	Test set
Capacitance-Inductance-Resistance Bridge ZM-30/U	Bridge
Red Test Lead CX-3644/U	Red test lead
Black Test Lead CX-3645/U	Black test lead
Electron ray tube shield	Tube shield

## 6. Components

(fig. 1 and 2)

The components listed below are supplied as part of Capacitance-Inductance-Resistance Test Set AN/URM-90. This list is for general information only. Refer to appropriate supply publications for information pertaining to requisition of spare parts.

Component	Required No.	Height (in.)	Width (in.)	Depth (in.)	Weight (lb)
Capacitance-Inductance-Resistance Bridge ZM-30/U	1	10½	11½	11	20%
Red Test Lead CX-3644/U	1	(elliptical)	19 lg		
Black Test Lead CX-3645/U	1		19 lg		
Electron ray tube shield	1				
Allen set screw wrenches No. 8	2				
Allen set screw wrenches No. 10	2				
Set of spare parts consisting of:	1				
Electron tube, 12AX7	1				
Electron tube, 12AT7	1				
Electron ray tube, 6U5	1				
Fuses (3-ampere)	4				
Pilot Lamps LM-52	3				

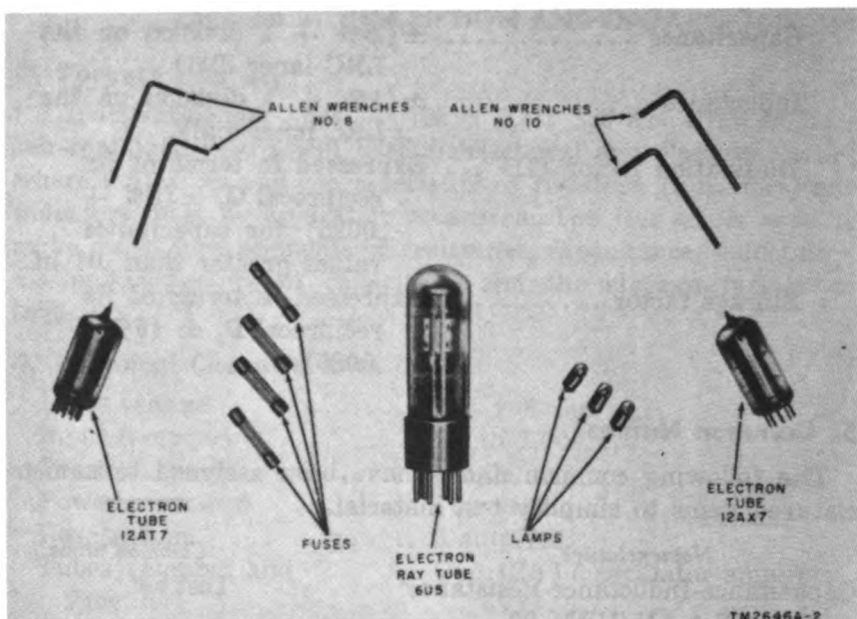

**Figure 2.** Tools and spare parts of Capacitance-Inductance-Resistance Test Set AN/URM-90.

## 7. Description of Test Set

(fig. 1)

*a. Bridge.* Capacitance-Inductance-Resistance Bridge ZM-30/U is housed in an aluminum case which has a detachable case cover. All controls are located and identified on the front panel. A carrying handle is mounted on the top of the case. The detachable cover, which protects the operating controls when the test set is not in use, contains a storage compartment for the spare parts, tools, and minor components supplied with the test set.

*b. Test Leads.* There are two test leads, 19 inches long; one colored red the other colored black, for identification purposes. One end of each test lead is terminated with a pin incased in a colored (red or black) plastic case. The other ends are provided with alligator clips partially incased in a protective plastic case.

*c. Tube Shield.* The tube shield is round and made of black anodized aluminum. One end is angled slightly to provide a more effective shield against outside light when making measurements. The relatively short over-all length ( $1\frac{1}{8}$  inches) allows the tube shield to remain in place, around the electron ray tube, when the case cover is attached.

*d. Tools.* Special tools (fig. 2), two No. 8 and two No. 10 Allen wrenches, are supplied with the test set for disassembly purposes.

## 8. Additional Equipment Required

The following equipments are *not* supplied with the test set, but are required to perform some of the tests listed in chapter 3.

Additional equipment	Use	Technical manual
Audio Oscillator TS-382/U	External generator for frequencies other than 1,000 cycles per second.	TM 11-2684
Headset (Navy type head-set CW-49507, Signal Corps stock No. 2B955)	Audio detector for ac measurements.	
Voltmeter ME-30A/U	Meter detector for ac measurements.	
Multimeter TS-297/U	Milliammeter for current measurements.	TM 11-5500
Laboratory Standard AN/URM-2	Standard precision capacitors and inductors for ac measurements.	
Decade Resistor TS-679A/U	Calibrated decade resistor for extending $D-Q$ range of bridge and for use when measuring paralleled capacitance and resistance of a capacitor.	TM 11-5520

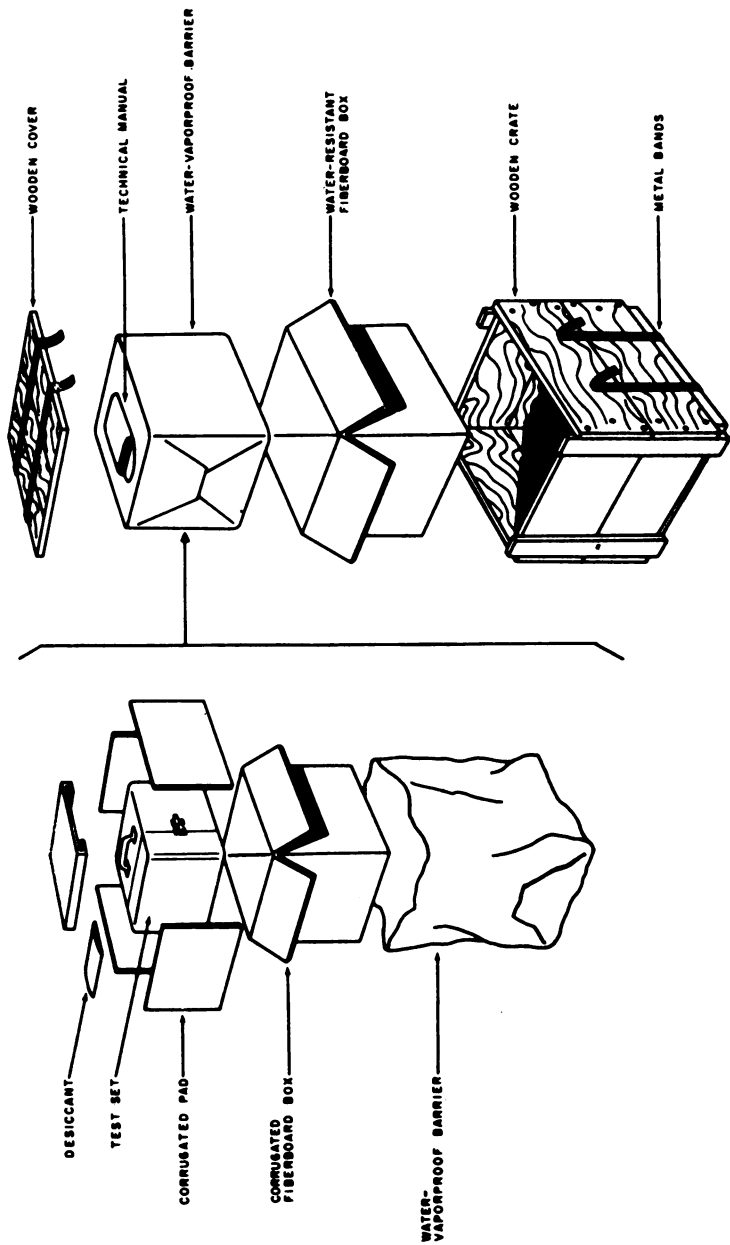

TM2646A-3

Figure 3. Capacitance-Inductance-Resistance Test Set AN/URM-90, packaging diagram.

## CHAPTER 2

### INSTALLATION

---

#### 9. Uncrating and Unpacking New Equipment

*a. Packaging Data* (fig. 3). The tools, spare parts, and accessories furnished with each test set are wrapped and packed in the compartment on the inside of the test set cover. The test set is packed in a sealed corrugated fiberboard carton, wrapped in water-vaporproof barrier material and packed in a second water-resistant fiberboard carton. The sealed package is then packed in a nailed wooden crate. Test sets packed for export shipment are strapped with metal bands; test sets packed for domestic shipment are not strapped. The shipping package, before it is unpacked, is 22 inches high, 14 inches wide, 10 inches deep; has a volume of 1.8 cubic feet; and weighs 57 pounds.

*b. Removing Contents.*

**Caution:** Be extremely careful when unpacking the test set. Do not thrust tools into the container. Damage may result. The test set is a precision instrument and mishandling can easily cause damage to the equipment.

- (1) Cut the metal bands at a point just below the wooden crate cover.
- (2) Use a nail puller and remove the nails from the crate cover.
- (3) Remove the wooden cover and take out the water-resistant fiberboard box. Cut through its three upper edges. The uncut edge will act as a hinge.
- (4) Remove the set inclosed in the water-vaporproofed barrier from the fiberboard box. Loosen the water-vaporproofed barrier by cutting as close to the seal as possible.
- (5) Carefully remove the barrier and open the inner carton by cutting its three upper edges.
- (6) Take the corrugated pads and desiccant from around the test set and remove the test set from the corrugated fiberboard box.

## **10. Checking**

- a.* Place the test set on a work bench and inspect its case for external damage.
- b.* Unlatch the two spring catches on the side of the test set and remove the case cover (fig. 1).
- c.* Examine the front panel for possible damage to controls, knobs, and galvanometer.
- d.* Open the storage compartment cover by loosening the locking screw and raising the cover.
- e.* Check the bridge and contents of the storage compartment with the master packing slip.

## **11. Installation of Equipment**

- a.* Place the test set on a firm support, such as a bench or table, so that the controls on the front panel are convenient to the operator.
- b.* Connect the power cable to a power source of 115 volts alternating current (ac), 50 to 1,000 cycles per second, (CPS).
- c.* If the test leads are to be used, connect them to the appropriate pair of binding posts for the type of measurement to be made (fig. 1). (Regardless of the pair of binding posts used, connect the red test lead to the red binding post and the black test lead to the black binding post.)
- d.* Push the flat edge of the tube shield into the panel cut out around the electron ray tube.

## **12. Service Upon Receipt of Used or Reconditioned Equipment**

- a.* Follow the instructions in paragraphs 9 and 10 for uncrating, unpacking, and checking the equipment.
- b.* Check the used or reconditioned equipment tags or other indications pertaining to changes in the wiring of the equipment. If any changes in wiring have been made, note the change in this manual, preferably on the schematic and wiring diagrams.
- c.* Perform the installation and connection procedures given in paragraph 11.

## CHAPTER 3

### OPERATION

---

#### Section I. CONTROLS AND INSTRUMENTS

*Note.* Haphazard operation or improper setting of the switches and controls can damage the bridge. For this reason, it is important to know the function of every control. Detailed operation of the bridge is discussed in paragraphs 17 through 44.

#### 13. General

The controls of the test set (fig. 4) are listed and described in paragraphs 14 and 15 below. The functions of the bridge ratio dials and switches (CIRCUIT SELECTOR and Q, D-Q, & R DIAL MULTIPLIER, LRC DIAL MULTIPLIER, LRC dial, and the D and D-Q dial) are outlined in paragraph 14. The remaining controls and instruments are listed in paragraph 15. Binding posts and their uses are described in paragraph 16.

#### 14. Bridge Ratio Dials and Switches and Their Uses

(fig. 4)

*a. Circuit Selector Switch.* The CIRCUIT SELECTOR AND Q, D-Q, & R DIAL MULTIPLIER (circuit selector switch) is a three-section, six-position switch of make-before-break type. The switch provides a method of altering the bridge circuitry for selection of the specific type bridge (Wheatstone, Maxwell, Hay, or capacitance) required for the measurement to be made. In addition, the circuit selector switch selects the proper test range for a particular bridge arm, consistent with the approximate value of the unknown component. A table of the circuit selector switch positions and their uses follows:



Circuit selector switch		Resultant bridge circuit	Electrical measurement	Read
Circuit Indication (ckt)	Dial setting			
L	D-Q x 1	Maxwell inductance bridge.	Measures inductance of inductors having storage factors (Q) between .2 and 10.5. Measures inductance of inductors having storage factors (Q) between 9.5 and 1,000.	Read inductance in henries from LRC dial and L reading on LRC DIAL MULTIPLIER.
L	Q x 100	Hay inductance bridge.	Measures resistance from 1 milliohm to 1.1 megohm.	Read resistance from LRC dial and R reading on LRC DIAL MULTIPLIER.
E	R x 1	Wheatstone resistance bridge.	Measures resistance from 1 megohm to 11 megohms.	Read LRC dial and C reading on LRC DIAL MULTIPLIER.
E	R x 10	Wheatstone resistance bridge.	Measures capacitance of capacitors having dissipation factors (D) between .001 and .105.	
C	D-Q x .01	Capacitance bridge.	Measures capacitance of capacitors having dissipation factors (D) between .1 and 1.05.	
C	D-Q x 0.1	Capacitance bridge.		

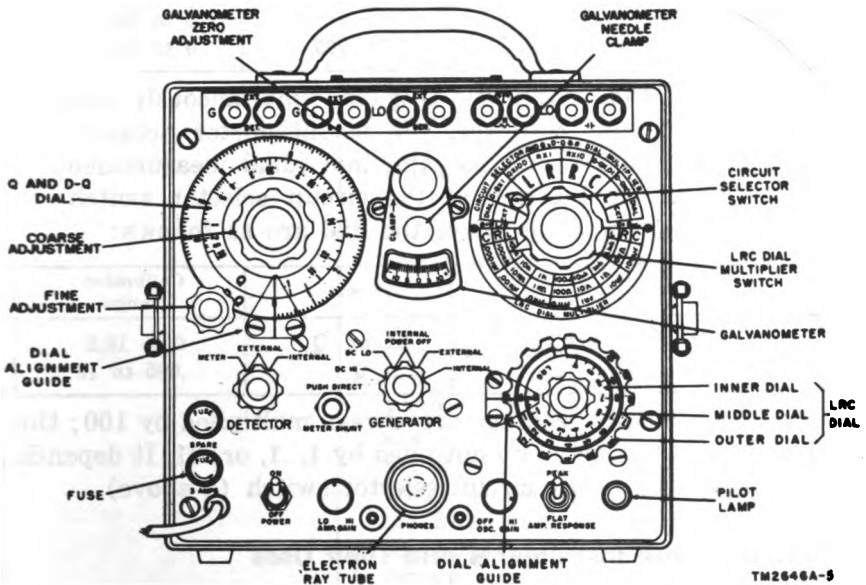

Figure 4 Bridge, showing front panel controls.

b. **LRC DIAL MULTIPLIER.** The LRC DIAL MULTIPLIER is a seven-position switch that provides a means of selecting the proper ratio factor to achieve bridge balance for component measurements. The switch indication, therefore, operates as the multiplying factor for the LRC dial (c below). The following table lists the proper scale when measuring resistance, capacitance, and inductance:

Type measurement	Scale	Multiplier range
Resistance	Middle scale marked R	0.1 $\Omega$ to 100k
Capacitance	Outer scale marked C	.0001 uf to 100 uf
Inductance	Inner scale marked L	0.1 mh to 100 h

c. **LRC Dial.** The LRC dial is a three-section switch that controls the bridge arm decade resistors and a series potentiometer. The resistance controlled by the dial forms one of the bridge arms and is proportionally indicated on the face of the dial by three

concentric calibrated scales. The scales are marked in <sup>c1</sup> tens, tenths, and hundredths as follows :

Dial scale	Calibrated range	Resistance range (ohms)
<u>Tens</u> (outer dial)	0 to 10	0 to 10,000
Tenths (middle dial)	0 to .9	0 to 900
Hundredths (inner dial)	0 to .105	0 to 105

d. *Q and D-Q Dial.* The Q and D-Q dial simultaneously controls three potentiometers. However, the potentiometer actually included in the bridge circuit for any individual measurement is dependent upon the position of the circuit selector switch (*a* above). The scales and ranges of the dial are as follows :

Scale	Read	Calibrated range
D-Q (outer black scale)	D or Q	0 to 10.5
Q (inner red scale)	Q	.095 to 10

*Note.* The red scale readings are always multiplied by 100; the black scale readings may be multiplied by 1, .1, or .01. It depends on the dial setting of the circuit selector switch (*a* above).

## 15. Controls and Instruments and Their Uses

The following chart lists the switches, controls, and instruments of the test set, except those listed in paragraph 14, and indicates their functions.

Controls and instruments	Description and function
POWER switch	A two-position toggle switch. ON position: Connects power to the bridge. OFF position: Disconnects power from the bridge.
DETECTOR switch .	A three-position rotary switch that selects the proper detection circuit depending upon the measurement being made as follows:  METER position: Connects the bridge detection circuits directly to the galvanometer (M1).  EXTERNAL position: Connects the bridge detection circuits directly to the EXT. DET. binding posts for use of external detector.  INTERNAL position: Connects the bridge detection circuits directly to the test set amplifier and electron ray tube.

Controls and instruments	Description and function
<b>METER SHUNT switch</b>	A two-position push-type switch which when depressed to <b>PUSH DIRECT</b> position, connects galvanometer M1 for increased meter sensitivity.
<b>GENERATOR switch</b>	<p>A five-position rotary switch that controls the voltage distribution in the test set as follows:</p> <p><b>DC HI position:</b> Connects approximately 250 volts dc from the high-voltage power supply to the bridge network excitation circuit.</p> <p><b>DC LO position:</b> Connects approximately 10 volts dc from the low-voltage power supply to the bridge network excitation circuit.</p> <p><b>INTERNAL POWER OFF position:</b> Disconnects all operating voltages from the test set operating circuits.</p> <p><b>EXTERNAL position:</b> Permits plate voltage to be applied to electron tubes V1, V2, and V3; the excitation circuit of the bridge network is connected directly to the <b>EXT. GEN.</b> binding posts to permit use of an external power source.</p> <p><b>INTERNAL position:</b> Connects plate voltage to electron tubes V1, V2, and V3 and the 1,000-cycle excitation voltage from transformer T1 directly across the bridge network excitation circuit.</p>
<b>AMP. GAIN control</b>	A potentiometer used to increase or decrease the amplitude of the detection signal.
<b>OSC. GAIN control and switch</b>	<p>A potentiometer incorporating a two-position switch is used to increase or decrease the amplitude of oscillator voltage.</p> <p><b>OFF position:</b> The switch opens the plate voltage circuit of the oscillator-amplifier circuit thereby disconnecting oscillator-amplifier (V1).</p>
<b>AMP. RESPONSE switch</b>	<p>A two-position toggle switch that functions as follows:</p> <p><b>FLAT position:</b> Disconnects the filter network from the amplifier circuit.</p> <p><b>PEAK position:</b> Connects the filter network to the amplifier circuit to sharpen null indication.</p>

Controls and instruments	Description and function
<b>GALVANOMETER</b>	Used to indicate the degree of balance of the test set when making dc resistance measurements. A zero adjustment knob cap provides a means of mechanically centering the needle. The needle clamp in the center of the galvanometer provides a means of locking the meter needle in the centered position, when operated in the direction of the arrow molded in the case.
Electron ray tube	Indicates an ac null in the bridge when the DETECTOR switch is in the INTERNAL position and inductance and capacitance are being measured.
Pilot lamp	A red lamp that lights when power is applied to the test set power supply and extinguishes when power is disconnected.

## 16. Binding Posts, Jacks, and Their Uses

(fig. 5)

The following chart describes the binding posts and jacks of the test set and indicates their functions:

Binding posts or jacks	Description and function
PHONES (jacks)	The two jacks provide means for connecting Navy type Headset CW-49507 for aural detection purposes.
EXT. DET.	The two posts provide means for connecting external detecting devices such as Voltmeter ME-30A/U.
EXT. D-Q	The two posts are provided to allow the extension of D-Q range (par. 38b). (During normal test set operation, the binding posts must be shorted with a busbar.)
EXT. GEN.	The two posts are used to connect an external dc voltage source or Audio Oscillator TS-382/U to the bridge.
L and R	The two posts are used to connect an unknown inductor or resistor to the bridge for measurement.
C	The two posts are used to connect an unknown capacitor to the bridge for measurement.

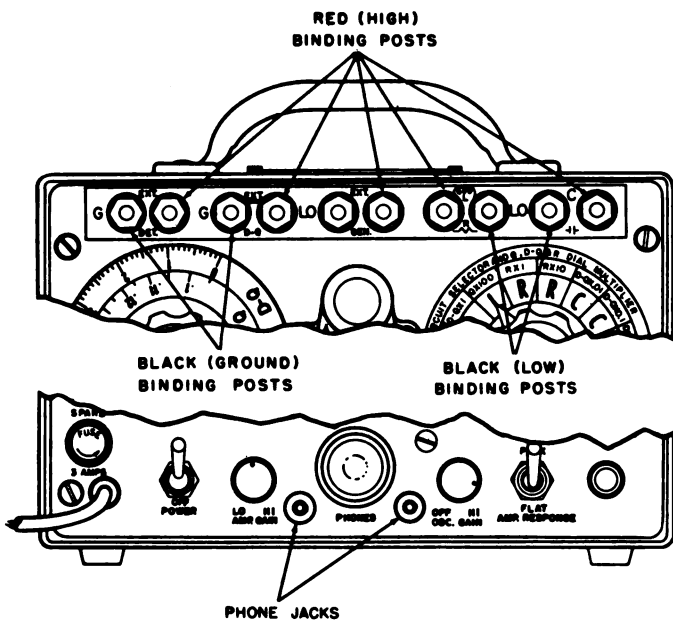

TM2646A-6

Figure 5. Bridge, showing binding posts and jacks.

## Section II. OPERATION UNDER USUAL CONDITIONS

*Note.* Capacitance-Inductance-Resistance Test Set AN/URM-90 is a precision instrument designed for use under laboratory conditions. If the test set is used in areas of high humidity the accuracy of the instrument will be affected.

### 17. Starting Procedure

- a. Push the POWER switch (fig. 4) to the ON position. The pilot lamp should light.
- b. Turn the GENERATOR switch to the INTERNAL POWER OFF position.
- c. Connect the particular component to be measured to the pair of binding posts, indicated by the test being performed (par. 18 through 44).

### 18. Dc Resistance Measurements

- a. Lay the bridge on its back with the panel facing upwards and connect the unknown resistance ( $R_u$ ) to the binding posts marked L and R (fig. 6). Release the galvanometer movement by moving the clamp in the direction opposite to that indicated by

the arrow (fig. 4). If the galvanometer needle does not center, adjust it to zero as follows:

- (1) Loosen the screw on the right-hand side of the galvanometer zero adjustment knob 1 full turn.
- (2) Adjust the galvanometer zero adjustment knob until the needle indicates 0.
- (3) Tighten the screw ((1) above).

b. Operate the circuit selector switch to the R and R x 1 position (fig. 6).

c. Operate the DETECTOR switch to the METER position.

d. Operate the GENERATOR switch to the DC LO position.

e. Adjust the LRC DIAL MULTIPLIER until the galvanometer needle is on scale with the least amount of deflection.

f. If the galvanometer needle cannot be adjusted to zero, place the circuit selector switch in the R and R x 10 position (fig. 7) and repeat the operation described in e above.

*Note.* If it is necessary to perform the procedure outlined in f above, the accuracy of the resistance measurement will be improved by operating the GENERATOR switch to the DC HI position before making the adjustments outlined in e above.

g. Beginning with the LRC dial set at 1.00 (outer dial set at 1., middle dial and inner dial each set on 0), adjust the outer dial until the galvanometer needle is as close to zero as possible. Adjust the middle dial until the galvanometer needle is closer to zero.

h. To make the final adjustment of the LRC dial, push in and hold the METER SHUNT switch and then adjust the inner dial until a zero reading is obtained on the galvanometer.

i. To obtain the value of the unknown resistor, multiply the LRC dial reading by the LRC DIAL MULTIPLIER setting and, if the circuit selector switch has been set at R and R x 10, multiply the product by 10. Refer to examples 1 and 2 below for the proper method of calculating measured resistance in each position of circuit selector switch.

**Caution:** Do not remove the resistor under measurement until the GENERATOR switch is turned to the INTERNAL POWER OFF position because damage may result to the galvanometer and internal resistors.

*Example 1:* Settings of controls in figure 6 are for the final balance positions of a dc resistance of .556 ohm. Observe and interpret the control readings as follows:

Circuit selector switch reads ..... R and R x 1.  
LRC DIAL MULTIPLIER reads ..... 0.1Ω.  
LRC dial reads ..... 5.560.

**Formula :**

$$R_a = \text{Circuit selector switch reading} \times \text{LRC DIAL MULTIPLIER reading} \times \text{LRC dial reading}$$

**Substituting :**

$$R_a = (1) \times (.1) \times (5.56)$$

**Therefore :**

$$R_a = .556$$

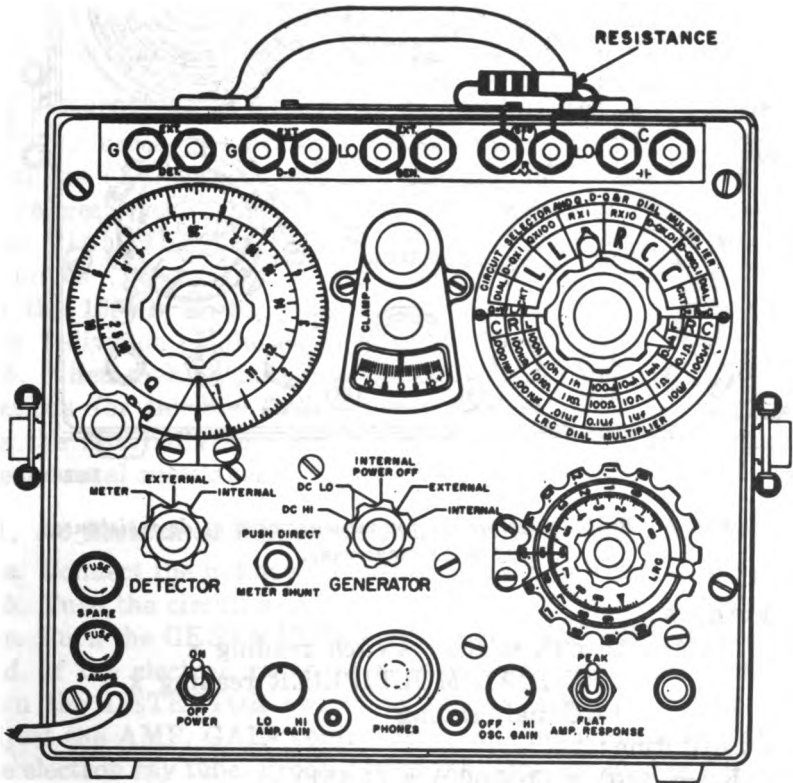

TM2646A-7

*Figure 6. Bridge controls set for measurement of dc resistance (.001 ohm to 1 ohm).*

**Example 2:** Settings of controls in figure 7 are for the final balance position of a dc resistance of 1.151 megohms. Observe and interpret the control readings as follows :

- Circuit selector switch reads ..... R and R x 10.
- LRC DIAL MULTIPLIER reads ..... 100k $\Omega$ .
- LRC dial reads ..... 1.151.



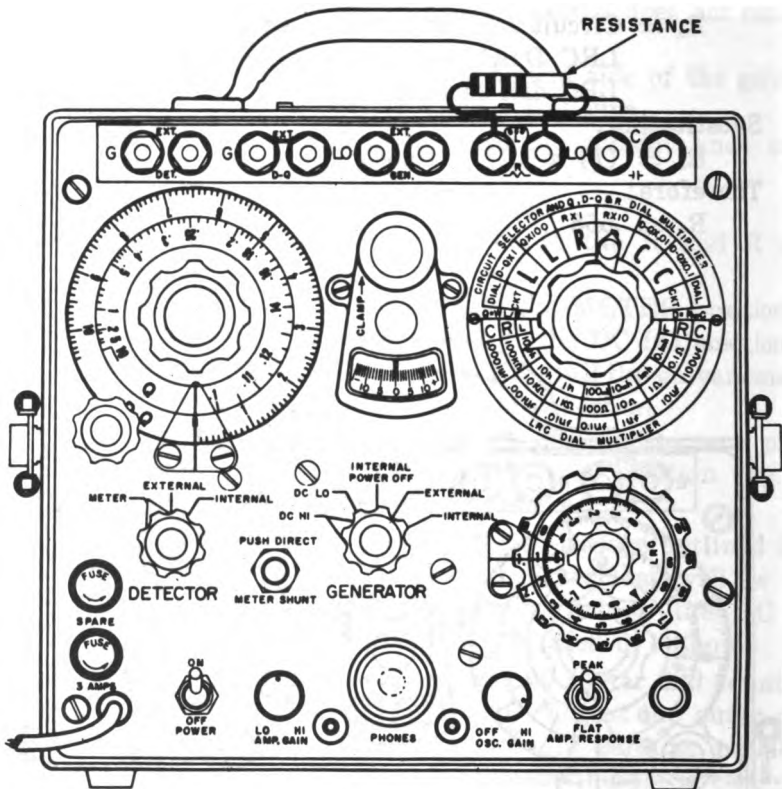

Figure 7. Bridge controls set for measurement of dc resistance (1 to 11 megohms).

Formula:

$$R_u = \text{Circuit selector switch reading} \times \text{LRC DIAL MULTIPLIER reading} \times \text{LRC dial reading}$$

Substituting:

$$R_u = (10) \times (100,000) \times (1.151)$$

Therefore:

$$R_u = 1,151,000 \text{ ohms or } 1.151 \text{ megohms}$$

## 19. Corrections for Internal Resistance of Bridge

Correction for internal resistance of the bridge are made when the bridge is used to measure resistances so low that the LRC DIAL MULTIPLIER is set at 0.1 on the R scale and the circuit selector switch is set at R and R x 1 as shown in figure 6 (resistances of less than 1 ohm). To make corrections for internal resistance of the bridge, proceed as follows:

a. If the test leads are connected to the L and R binding posts, short the alligator clips together.

b. If the test leads are not used, connect a short, heavy copper conductor (at least a #12 AWG, bare, copper wire) securely between the L and R binding posts of the bridge. These connections are made in the same way as those for the resistance shown in figure 6.

c. Measure and calculate the resistance as described in paragraph 18. This measured resistance is the internal resistance of the bridge.

d. To obtain the accurate resistance of the unknown resistance, subtract the measured internal resistance (c above) from that of any resistance of less than 1 ohm.

## 20. Accuracy of Dc Resistance Measurements

a. The error in resistance measurements will not exceed plus or minus (.15 per cent plus 1 division of the inner LRC dial) on all ranges; except the 0.1 $\Omega$  and 100K $\Omega$  ranges, indicated by the LRC DIAL MULTIPLIER. On the 0.1 $\Omega$  range, the error is plus or minus (.35 per cent plus 1 division on the inner LRC dial). On the 100K $\Omega$  range, the error is plus or minus (.2 per cent plus 1 division on the inner LRC dial).

b. When making measurements on the 0.1 $\Omega$  range, make corrections for the zero resistance of the test leads, if used, and for the internal resistance of the test set (par. 19). Normally, the internal resistance is approximately .002 ohm.

## 21. Ac Resistance Measurements at 1,000 Cps

a. Connect the unknown resistor to the L and R binding posts.

b. Turn the circuit selector switch to the R and R x 1 position.

c. Turn the GENERATOR switch to the INTERNAL position.

d. If the electron ray tube is to be used as the null detector, turn the DETECTOR switch to the INTERNAL position and adjust the AMP. GAIN control for a minimum shadow width on the electron ray tube. Proceed with the steps outlined in f through j below.

e. If either the headset (Navy type headset CW-49507) or Voltmeter ME-30A/U is to be used as a null detector, omit the step outlined in d above and proceed as follows, before continuing with the operating procedure outlined in f through j below:

- (1) When the headset is used, turn the DETECTOR switch to the INTERNAL position. Place the headset cord connectors in the PHONES jacks (fig. 5) at the bottom of the front panel. A null is indicated by minimum sound in the headset.

(2) When Voltmeter ME-30A/U is used, turn the DETECTOR switch to the EXTERNAL position and proceed as follows:

- (a) Use the voltmeter test leads; connect one lead between the EXT. DET. G binding post on the bridge and the INPUT G terminal of ME-30A/U. Connect the second test lead between the EXT. DET. (high) binding post of the bridge and the unmarked INPUT terminal of the voltmeter.
- (b) Move the ON-OFF switch of the voltmeter to the ON position.
- (c) Set the voltmeter range switch to the 10 position. If the null signal (a minimum reading on the meter scale) cannot be readily detected at the 10 setting, adjust the voltmeter range switch gradually to lower ranges.

f. Turn the OSC. GAIN control clockwise from the OFF position. Adjust the OSC. GAIN control toward the HI position to increase the sensitivity of the null indication.

g. Turn the LRC dial to read approximately 1.00.

h. Adjust the LRC DIAL MULTIPLIER for minimum signal (widest shadow) on the electron ray tube.

i. Adjust the LRC dial (first outer dial, then middle dial and finally, inner dial) for the best null indication in *e* or *h* above. If a satisfactory minimum cannot be obtained with the LRC dial, readjust the position of the LRC DIAL MULTIPLIER, and again turn the LRC dial for minimum signal.

j. Calculate the ac resistance of the unknown resistor ( $R_u$ ) by multiplying the LRC dial reading by the indicated resistance (R) value on the LRC DIAL MULTIPLIER; multiply the product of  $R_u$  and R by the multiplier indicated by the setting of the circuit selector switch. Refer to the example below.

*Example:* Settings of controls in figure 8 are for the final balance position of an ac resistance of 8,501 ohms. Observe and interpret the control readings as follows:

Circuit selector switch reads ..... R and R x 1.  
LRC DIAL MULTIPLIER reads ..... 1k $\Omega$ .  
LRC dial reads ..... 8.501.

Formula:

$$R_u = \text{Circuit selector switch reading} \times \text{LRC DIAL MULTIPLIER reading} \times \text{LRC dial reading}$$

Substituting:

$$R_u = (1) \times (1,000) \times (8.501)$$

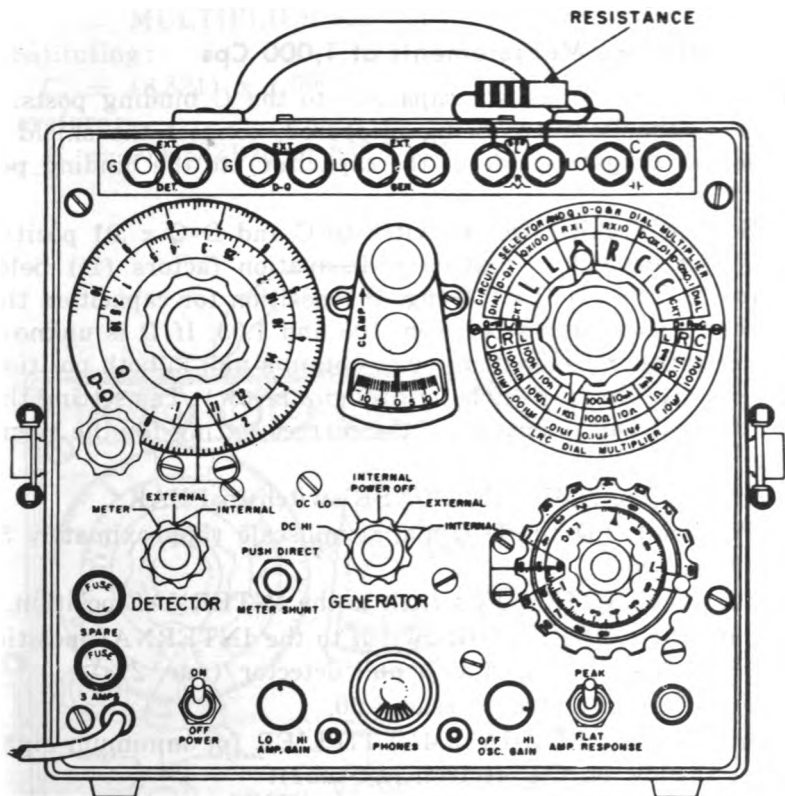

TM2648A-9

Figure 8. Bridge controls settings for measurement of ac resistance.

Therefore:

$$R_u = 8,501 \text{ ohms}$$

## 22. Accuracy of Ac Resistance Measurements

The error of ac resistance measurements is within plus or minus (.5 per cent plus 1 division on the inner LRC dial) from 1 to 100,000 ohms. The error may increase to plus or minus (1 per cent plus 1 division on the LRC inner dial) for values of resistance lower than 1 ohm (par. 19) and greater than 100,000 ohms.

*Note.* If a null cannot be obtained or is not sharply defined, it is probable that the resistance under measurement contains considerable reactance. A good balance can be obtained only when the unknown resistor has a small reactance comparable to that of

the resistors which make up the bridge circuit. To measure resistors with appreciable reactance, refer to paragraph 32.

### 23. Capacitance Measurements at 1,000 Cps

a. Connect the unknown capacitor to the C binding posts. If polarized capacitors are being measured, connect the shield or outside foil (negative side of the capacitor) to the binding post marked LO.

b. Set the circuit selector switch to C and D-Q x .01 position (fig. 9) for capacitors that have dissipation factors (D) below .105 and to C and D-Q x 0.1 (fig. 10) position for capacitors that have dissipation factors between .105 and 1.05. If D is unknown and cannot be approximated, try to obtain a null in both positions of the circuit selector switch (c through i below). The setting that gives the best null indication is the correct setting for the circuit selector switch.

c. Operate the AMP. RESPONSE switch to PEAK.

d. Position the Q and D-Q dial at midscale (approximately 5.2 on the D-Q scale).

e. Turn the DETECTOR switch to the INTERNAL position.

f. Turn the GENERATOR switch to the INTERNAL position unless ME-30A/U is used as a null detector (par. 21e).

g. Turn the LRC dial to read 1.00.

h. Adjust the LRC DIAL MULTIPLIER for minimum signal (widest shadow on the electron ray tube).

i. Adjust the LRC dial and the Q and D-Q dial alternately until the best null indication is obtained. If a sharp null cannot be obtained, operate alternately in small increments, the AMP. GAIN and OSC. GAIN controls toward their HI positions until a sharp null is defined on the electron ray tube. If further operation of the Q and D-Q dial does not increase the shadow width on the electron ray tube, use Decade Resistor TS-679A/U to extend the D-Q range (par. 38b).

j. To determine the series capacitance ( $C_s$ ) of the unknown capacitor, multiply the LRC dial reading by the reading on the LRC DIAL MULTIPLIER. Refer to examples 1 and 2 below.

*Example 1:* The controls as pictured in figure 9 are for the final balance positions of a capacitor with a capacitance of 832.1 uuf. Observe and interpret the control readings as follows:

Circuit selector switch reads ..... C and D-Q x .01.

Q and D-Q dial (D-Q scale) reads ..... 1.10.

LRC DIAL MULTIPLIER reads ..... .0001 uf.

LRC dial reads ..... 832.1.

Formula:

$$C_s = \text{LRC dial reading} \times \text{LRC DIAL MULTIPLIER reading}$$

Substituting:

$$C_s = (8.321) \times (.0001)$$

Therefore:

$$C_s = .0008321 \text{ uf or } 832.1 \text{ uuf.}$$

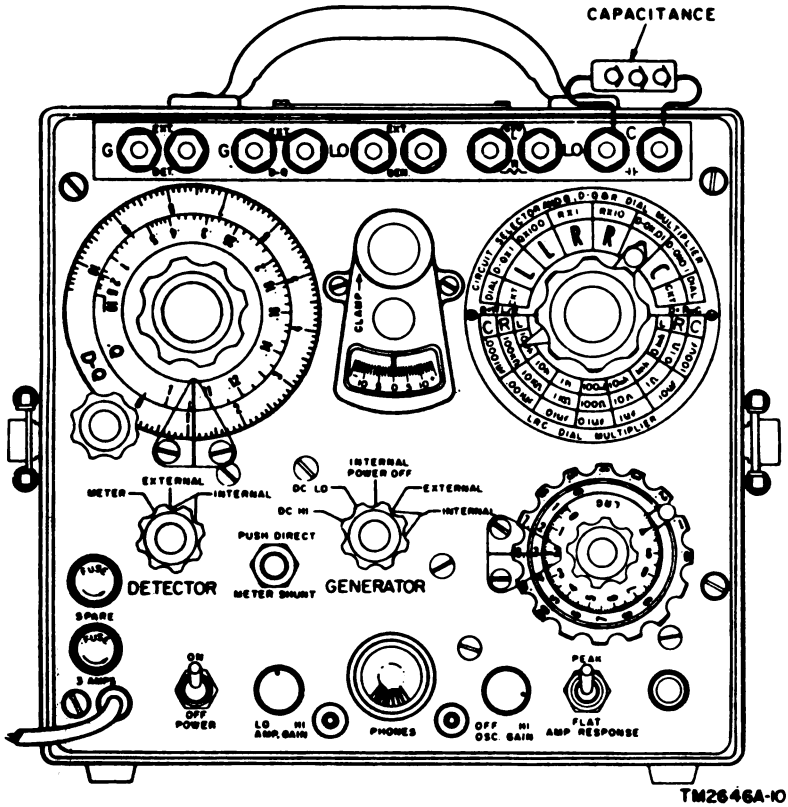

Figure 9. Bridge controls set for measurement of capacitors with dissipation factors (.001 to .105).

Example 2: The controls as pictured in figure 10 are for the final balance positions of a capacitor with a capacitance of 109.3 uf. Observe and interpret the control readings as follows:

- Circuit selector switch reads ..... C and D-Q x 0.1.
- Q and D-Q dial (D-Q scale) reads ..... 9.10.
- LRC DIAL MULTIPLIER reads ..... 10 uf.
- LRC dial reads ..... 10.930.

Formula:

$$C_s = \text{LRC dial reading} \times \text{LRC DIAL MULTIPLIER reading}$$

Substituting:

$$C_s = (10.93) \times (10)$$

Therefore:

$$C_s = 109.3 \text{ uf}$$

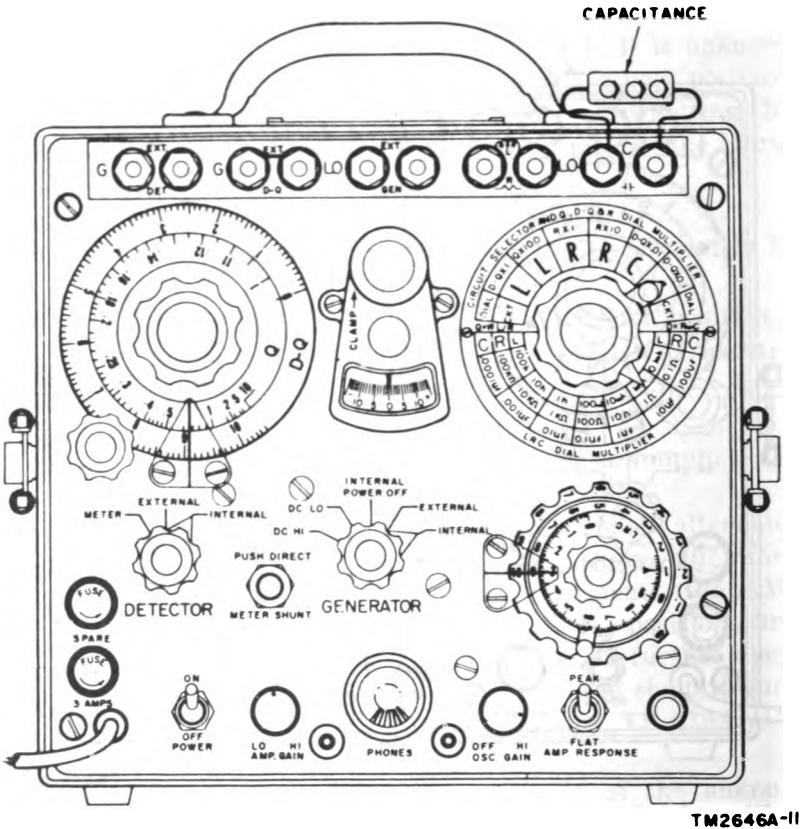

Figure 10. Bridge controls set for measurement of capacitors with dissipation factors of .1 to 1.05.

k. To find the dissipation factor ( $D = R/X = R \cdot \omega C_s$ ; where  $R_s$  is the series resistance,  $\omega$  is equal to  $2\pi f$  (or  $6.2832 \times$  frequency),  $X$  is the reactance, and  $C_s$  is the capacitance) of the unknown capacitor, multiply the reading on the Q and D-Q dial by the multiplication factor indicated on the circuit selector switch. Refer to examples 3 and 4 below.

**Example 3:** The controls that are shown in figure 9 are for the final balance positions of a capacitor with a dissipation factor (D) of .0110. The control readings are observed as in example 1 above.

Formula:

$$D = \text{Circuit selector switch reading} \times Q \text{ and D-Q dial reading}$$

Substituting:

$$D = (.01) \times (1.10)$$

Therefore:

$$D = .0110$$

**Example 4:** The controls that are shown in figure 10 are for the final balance positions of a capacitor with a dissipation factor (D) of .910. The control readings are observed as in example 2 above.

Formula:

$$D = \text{Circuit selector switch reading} \times Q \text{ and D-Q dial reading}$$

Substituting:

$$D = (9.10) \times (.1)$$

Therefore:

$$D = .910$$

i. Parallel capacitance ( $C_p$ ), series ac resistance ( $R_s$ ), and parallel ac resistance ( $R_p$ ) may be computed by use of the following formulas:

$$(1) \text{ Parallel capacitance, } C_p = \frac{C_s}{1 + D^2}$$

$$(2) \text{ Series ac resistance, } R_s = \frac{D\omega}{C_s}$$

$$(3) \text{ Parallel ac resistance, } R_p = \frac{1 + D^2}{D^2} R_s \text{ or } \frac{1 + D^2}{D\omega C_s}$$

## 24. Accuracy of Capacitance Measurements at 1,000 Cps

a. The capacitance error is plus or minus (.5 per cent plus 1 division on the inner LRC dial) between 100 uuf (micromicrofarad) and 100 uf (microfarad), and may increase to plus or minus 2 per cent at values of capacitance above 100 uf. For smaller values of capacitance below 100 uuf, the error will be within 2 uuf if corrections are made for the internal capacitance of the bridge and test leads.

b. To measure the internal capacitance of the bridge only (approximately 2.5 uuf), open the C binding posts and follow the procedure outlined in paragraph 23.



c. To determine the capacitance of the bridge plus the test leads, disconnect the lead that is connected between the C (high) binding post and the capacitor under test at the capacitor terminal and measure the capacitance of the bridge and test leads (par. 23). Do not *disturb the relative position of the test leads*; improper capacitance readings will result.

## 25. Accuracy of Dissipation Factor Measurements

a. *General.* The accuracy of the dissipation factor measurements is dependent upon several factors. The most important of these factors are the value of the capacitor that is being measured, the capacitance characteristics of the particular test set, and the capacitance of the test leads, used for the measurements.

b. *Capacitors Above .01 Uf.* Dissipation factor error for capacitors above .01 uf is  $\pm (5\% + .0025)$ .

c. *Capacitors Above .001 Uf and Below .01 Uf.* To determine the dissipation factor error for capacitors above .001 uf and below .01 uf, proceed as follows:

- (1) Measure and note the dissipation factor (par. 23); use the .0001 uf position on the C scale of the LRC DIAL MULTIPLIER.
- (2) Repeat the step in (1) above using the .001 uf position on the C scale of the LRC DIAL MULTIPLIER.
- (3) Arithmetically subtract the reading on the Q and D-Q dial noted in (2) above from the reading noted in (1) above. The difference that results represents the dissipation factor error.
- (4) Make all measurements of capacitors above .001 uf and below .01 uf using the .001 uf position on the C scale of the LRC DIAL MULTIPLIER and subtract the error computed in (3) above.

d. *Capacitors Below .001 Uf.* To determine the dissipation factor error for capacitors below .001 uf, proceed as follows:

- (1) Measure and note the dissipation factor (par. 23); use the .0001 uf position on the C scale of the LRC DIAL MULTIPLIER.
- (2) Repeat the step in (1) above by using the .001 uf range.
- (3) Arithmetically subtract the reading on the Q and D-Q dial noted in (2) above from the reading noted in (1) above. The difference that results represents the dissipation factor error.
- (4) Make all measurements of capacitors below .001 uf by using the .0001 uf position on the C scale of the LRC

DIAL MULTIPLIER and subtract the error computed in (3) above.

## 26. Inductance Measurements at 1,000 Cps

a. Connect the unknown inductor to the binding posts marked L and R (fig. 11 and 12). Connect the shield, if any, to the binding post marked LO.

b. Set the circuit selector switch to L and D-Q x 1 for an inductor that has a storage factor (Q) of less than 10.5, and to L and Q x 100 for an inductor that has a storage factor between 9.5 and 1,000. If the approximate storage factor is not known, or cannot be determined, select either position of the circuit selector switch and try to obtain a null indication. If a null cannot be obtained in the position selected, the other position of the circuit selector switch is then the correct setting.

c. Position the Q and D-Q dial at midscale.

d. Turn the DETECTOR switch to the INTERNAL position unless an external detector (ME-30A/U) is used (par. 21e).

e. Turn the OSC. GAIN control clockwise from the OFF position approximately  $\frac{1}{4}$  turn.

f. Turn the GENERATOR switch to the INTERNAL position.

g. Move the AMP. RESPONSE switch to the PEAK position.

h. Turn the LRC dial to approximately 1.00.

i. Adjust the LRC DIAL MULTIPLIER for minimum signal on the electron ray tube (widest shadow). Make alternate adjustments of the LRC dial and the Q and Q-D dial for best null indication. If a sharp null indication cannot be obtained, alternately adjust the OSC. GAIN control and the AMP. GAIN control until a sharp null is obtained. (Adjustment of the OSC. GAIN control, when a null is noted, will narrow the shadow width on the electron ray tube and permit finer adjustment of the inner dial on the LRC dial and the Q and D-Q dial.) If further adjustment of the Q and D-Q dial fails to increase the shadow width on the electron ray tube, use Decade Resistor TS-679A/U to increase the range of the Q and D-Q dial (par. 38b).

j. To find the inductance of the unknown inductor, multiply the LRC dial reading by the reading of the LRC DIAL MULTIPLIER. This inductance is series inductance ( $L_s$ ) when the circuit selector switch is in the L and D-Q x 1 position, and parallel inductance ( $L_p$ ) when the circuit selector switch is in the L and Q x 100 position. Refer to examples 1 and 2 below for sample inductance calculations.

*Example 1:* The settings of the controls in figure 11 are for the final balance positions of an inductor that has an inductance of

.561 mh (millihenrys). Read and interpret the control readings as follows:

Circuit selector switch reads ..... L and D-Q x 1.  
 Q and D-Q dial (D-Q scale) reads ..... 2.30.  
 LRC DIAL MULTIPLIER reads ..... 1 mh.  
 LRC dial reads ..... 0.561.

*Note.* Read the D-Q (black) scale of the Q and D-Q dial when the circuit selector switch is in the L and D-Q x 1 position.

Formula:

$$L_s = \text{LRC dial reading} \times \text{LRC DIAL MULTIPLIER reading}$$

Substituting:

$$L_s = (0.561) \times (1)$$

Therefore:

$$L_s = 0.561 \text{ mh}$$

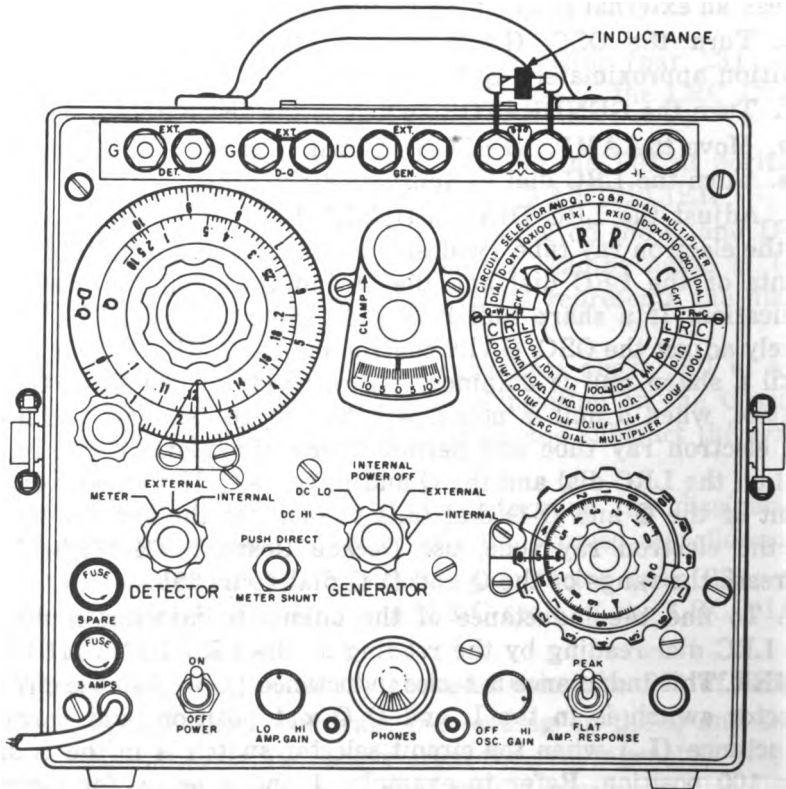

TM2646A-12

Figure 11. Bridge controls set for measurement of inductors with  
 saturation factors (.02 to 10.5).

**Example 2:** The settings of the controls in figure 12 are for the final balance positions of an inductor that has an inductance of 9.99 henrys. Read and interpret the control readings as follows:

- Circuit selector switch reads . . . . . L and Q x 100.
- Q and D-Q dial (Q scale) reads . . . . . .32.
- LRC DIAL MULTIPLIER reads . . . . . 1 h.
- LRC dial reads . . . . . .9.99.

**Note.** Read the Q (red) scale of the Q and D-Q dial when the circuit selector switch is in the L and Q x 100 position.

**Formula:**

$$L_p = \text{LRC dial reading} \times \text{LRC DIAL MULTIPLIER reading}$$

**Substituting:**

$$L_p = (9.99) \times (1)$$

**Therefore:**

$$L_p = 9.99 \text{ h}$$

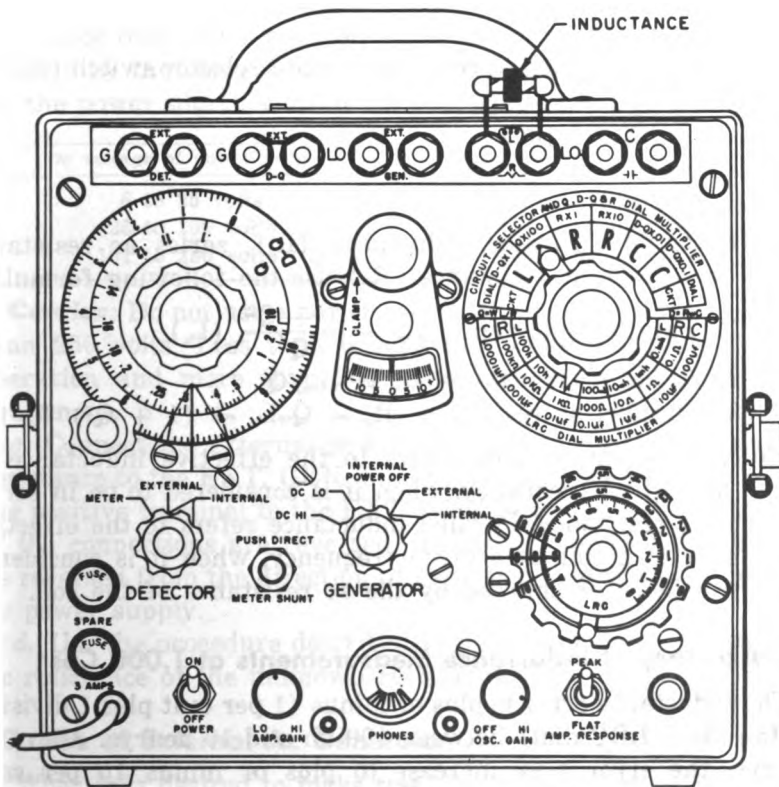

TM2646A-13

**Figure 12.** Bridge controls set for measurement of inductors with storage factors (9.5 to 1,000).

k. To find the storage factor ( $Q = X_s/R_s = \omega L_s/R_s$ ) of the unknown inductor, multiply the Q and D-Q dial reading by the factor that is indicated on the circuit selector switch. Refer to examples 3 and 4 below for sample calculations of Q.

*Example 3:* The settings of the controls that are shown in figure 11 are for the final balance positions of an inductor that has a storage factor (Q) of 2.30. The controls read as indicated in example 1 of j above.

Formula:

$$Q = Q \text{ and D-Q dial reading } \times \text{ circuit selector switch reading}$$

Substituting:

$$Q = (2.30) \times (1)$$

Therefore:

$$Q = 2.3$$

*Example 4:* The settings of the controls that are shown in figure 12 are for the final balance positions of an inductor that has a storage factor (Q) of 32. The controls read as in example 2 above.

Formula:

$$Q = Q \text{ and D-Q dial reading } \times \text{ circuit selector switch reading}$$

Substituting:

$$Q = (.32) \times (100)$$

Therefore:

$$Q = 32$$

l. To compute parallel inductance ( $L_p$ ), series ac resistance ( $R_s$ ), or parallel ac resistance ( $R_p$ ) use the following formulas:

$$(1) \text{ Parallel inductance, } L_p = \frac{1 + Q^2}{Q^2} (L_s)$$

$$(2) \text{ Series ac resistance, } R_s = \omega L_s / Q$$

$$(3) \text{ Parallel ac resistance, } R_p = Q \omega L_p = (1 + Q^2) R_s$$

*Note.* Series inductance refers to the effective inductance of a coil, at a given frequency, when it is considered to be in series with its ac resistance. Parallel inductance refers to the effective inductance of a coil, at a given frequency, when it is considered to be paralleled or shunted by the ac resistance of the coil.

## 27. Accuracy of Inductance Measurements at 1,000 Cps

The inductance error is plus or minus (1 per cent plus 1 division on the inner LRC dial) between 100 uh and 10 henrys. Above 10 henrys, the error may increase to plus or minus 10 per cent because of the increasing effect of the capacitances to ground associated with the inductor and the bridge arms. Below 100 uh, the error will be within plus or minus 2 uh.

## 28. Accuracy of Storage Factor Measurements

Storage factor error is always expressed in terms of its reciprocal (D) and is plus or minus (5 per cent plus .0025) for inductances up to 10 henrys. This error increases to plus or minus (5 per cent plus .015) at 100 henrys and to plus or minus (5 per cent plus .055) at 1,000 henrys. The increasing error appears with the increasing inductance. This is caused primarily by the small residual capacitances across the high impedance ratio arms.

## Section III. MISCELLANEOUS TEST SET APPLICATIONS

### 29. Use of External Dc Power Source

Under certain conditions, it may be necessary to measure dc (direct-current) resistance by using an external source of dc power. This is accomplished as follows:

- a. Turn the GENERATOR switch to the EXTERNAL position.
- b. Connect the external dc power source in series with a resistance that will adequately limit the current to a value safely handled by the test set. To obtain the proper value of resistance for the power source, consult the following table:

Dc voltage of power source	Proper value of series resistance
6 to 25 volts	10 ohms per volt
26 to 100 volts	30 ohms per volt
101 to 250 volts	100 ohms per volt

**Caution:** Do not use a power source of less than 6 volts or more than 250 volts. Less than 6 volts may cause improper test set operation and more than 250 volts may cause damage to the equipment.

c. Connect the external power source with its series-connected resistance to the EXT. GEN. binding posts of the bridge. Connect the positive terminal to the EXT. GEN. binding post marked LO. If the connections are reversed, the galvanometer deflection will be reversed from the direction of deflection caused by the internal dc power supply.

d. Use the procedure described in paragraph 18 to measure the dc resistance of the unknown resistance.

### 30. Use of External Ac Generator

When it is desired to make tests for capacitance or inductance at frequencies other than the internally supplied 1,000 cps (from 100 to 10,000 cps), Audio Oscillator TS-382/U is connected to

the bridge. To use the TS-382/U with the bridge, proceed as follows:

a. Electrically isolate the two units by placing each on a surface that is a nonconductor of electricity (an insulated surface).

**Caution:** If the metal cases, and consequently the chassis, of the bridge and the TS-382/U become connected to a common ground, improper readings on the bridge will result.

b. Connect the OUTPUT ground terminal of the TS-382/U to the EXT. GEN. binding post marked LO. Connect the red EXT. GEN. binding post to the other OUTPUT terminal of the TS-382/U.

c. Turn the GENERATOR switch to the INTERNAL POWER OFF position; operate the AMP. RESPONSE switch to the FLAT position, and apply power to the TS-382/U.

d. Select the desired frequency on the TS-382/U and proceed with the desired ac measurement (par. 23, 26, or 31).

### **31. Measurement of Ac Resistance at Frequencies Other than 1 Kc**

a. Connect Audio Oscillator TS-382/U (par. 30) to the EXT. GEN. binding posts.

b. Set the GENERATOR switch to the EXTERNAL position.

c. Turn the DETECTOR switch to the INTERNAL position.

d. Measure the ac resistance as outlined in paragraph 21. If a good null balance cannot be obtained, proceed as outlined in paragraph 32.

### **32. Measurement of Ac Resistance with Reactance**

To obtain a sharp null when measuring resistances that have appreciable reactance, connect a Standard Variable Capacitance, General Radio Type 722-D, (a component of Laboratory Standard AN/URM-2) across the appropriate bridge arm, or bridge component.

a. To measure resistances that have a considerable amount of associated capacitance, such as electrolytic capacitors, connect the standard variable capacitance across either the A or N arm of the bridge network as indicated in *d* below (fig. 20).

b. To measure resistances that have appreciable inductive reactance, such as some types of layer wound resistors, connect the standard variable capacitance across the B bridge arm as indicated in *d* below (fig. 20). The storage factor of the unknown impedance is of the form  $R\omega C$  where  $R$  is the resistance of the

bridge arm across which the standard variable capacitance is connected.

c. Unknown resistances that have appreciable associated inductive reactance also can be measured by connecting the standard variable capacitance in the U bridge arm either across the unknown resistance to make a parallel resonant bridge, or in series with the unknown resistance to make a series-resonant bridge (*d* below). The parallel or series inductance is calculated from the formula  $L = 1/\omega^2C$ , where *C* is the capacitance read from the standard variable capacitance at the conclusion of the test.

*d*. A table showing proper placement of the standard variable capacitance for determining the reactive component of an ac resistance follows:

Bridge arm (as indicated) in fig. 20)	Terminal connections for standard variable capacitor	Type of resistance	Type of reactance
A	C (high) and $C_{L_0}$	Parallel	Capacitive
N	L R (high) and G	Parallel	Capacitive
B	C (high) and G	Series	Inductive
U	L R (high) and L $R_{L_0}$	Parallel	Inductive
U	In series with unknown resistance $R_u$	Series	Inductive

*e*. Measurements of ac resistance with reactance are made as follows:

- (1) Connect the unknown resistor to the L and R binding posts. Connect the variable standard capacitance to the appropriate binding posts as indicated in *d* above.
- (2) Make the following switch settings:
  - (a) Turn DETECTOR switch to INTERNAL position.
  - (b) Turn GENERATOR switch to INTERNAL position.
  - (c) Turn LRC dial to approximately 1.00.
  - (d) Turn circuit selector switch to R and R x 1 position.
- (3) Adjust the LRC DIAL MULTIPLIER for minimum signal (widest shadow).
- (4) Alternately turn the LRC dial and the standard variable capacitance until a minimum signal (par. 21*e* or *h*) is obtained. If a balance cannot be obtained by using the LRC dial and variable capacitor, readjust the LRC DIAL MULTIPLIER ((3) above) and again adjust the LRC dial and standard variable capacitance for balance.
- (5) To find the value of the unknown resistor, multiply the LRC dial reading by the indicated resistance value on the LRC DIAL MULTIPLIER.



### 33. Measurement of Parallel Capacitance and Resistance of Capacitor

- a. Connect the unknown capacitor to the C binding posts with the shield or outside foil connected to the binding post marked LO.
- b. Connect Decade Resistor TS-679A/U between the C (high) binding post and any binding post marked G.
- c. Turn the circuit selector switch to C and D-Q x .01 or C and D-Q x 0.1.
- d. Turn the DETECTOR switch to the INTERNAL position.
- e. Turn the GENERATOR switch to the INTERNAL position.
- f. Set the LRC dial to read approximately 1.00.
- g. Adjust the LRC DIAL MULTIPLIER to obtain the widest shadow on the electron ray tube and adjust the LRC dial and the TS-679A/U alternately until the best null indication is obtained (par. 21e).
- h. To find the parallel capacitance ( $C_p$ ) of the unknown capacitor, multiply the LRC dial reading by the reading on the LRC DIAL MULTIPLIER. Read the capacitor resistance from the TS-679A/U.
- i. Compute parallel resistance ( $R_p$ ) from the following formula:

$$R_p = \frac{R_e \times R_a}{R_n}$$

where:  $R_e$  — the resistance of Decade Resistor TS-679A/U.

$R_a$  — the resistance of ratio arm A (fig. 20) as read from the LRC DIAL MULTIPLIER when the test set is balanced.

$R_n$  — the reading of the LRC dial multiplied by 1,000.

### 34. Measuring Capacitance of Three-terminal Capacitors

a. Connect the common terminal to any binding post marked G; connect the other two terminals of the capacitor to the C binding posts of the bridge.

*Note.* This places one section of the capacitance (the section connected between the C binding post marked LO and a binding post marked G) across the detector, and the second section of the capacitance (the section connected between the C (high) and G binding posts) across the standard .1 uf capacitor. The capacitance across the detection circuit will not disturb the measurement, while the capacitance across the standard capacitor will cause the test set to read low. The bridge will read low by the ratio of the added capacitance to the capacitance of the standard capacitor. For example, if the second section of the capacitance

across the .1 uf standard capacitor is .0001 uf, the bridge will read .1 per cent low.

b. Measure the capacitance of the unknown capacitor (par. 23).

### **35. Measuring Capacitance of Electrolytic Capacitors**

When measuring the capacitance of an electrolytic capacitor, apply a stabilizing (forming) voltage to the capacitor to obtain an accurate balance of the bridge. Place a dc polarizing battery, not greater than 200 volts, in series with the electrolytic capacitor being measured.

a. Connect the positive terminal of the battery to the C binding post marked LO. Connect the negative terminal of the battery to the negative terminal of the electrolytic capacitor.

b. Connect the positive terminal of the electrolytic capacitor to be measured to the red C (high) binding post of the test set.

c. Measure the capacitance of the unknown electrolytic capacitor (par. 23).

d. If the value of the leakage current is desired, set Multimeter TS-297/U to measure current in milliamperes (ma). Connect the TS-297/U in series with the positive battery terminal and the C binding post marked LO. The leakage current will be indicated on the TS-297/U.

### **36. Measuring Terminal Capacitance of Shielded Inductors**

a. Connect the terminal of the inductor, the capacitance of which is to be measured, to the C binding post marked LO; connect the shield of the inductor to the C (high) binding post.

b. Connect the remaining terminal of the inductor to any binding post marked G.

c. Measure the unknown capacitance (par. 23).

d. Measure the capacitance of the other terminal by reversing the two inductor connections. Leave the shield connected to the C (high) binding post, and follow the operating procedure described in paragraph 23.

*Note.* The terminal capacitance of an inductor is measured across the standard .1 uf capacitor in the bridge. The error introduced is usually negligible (approximately .5 per cent) because terminal capacitance of shielded transformers rarely exceed 500 uuf.

### **37. Determining Resonant Frequency of Inductor or Tuned Circuit**

a. Connect the unknown inductor or tuned circuit to the L and R binding posts, with the shield, if any, connected to the binding post marked LO.

b. Connect Audio Oscillator TS-382/U to the EXT. GEN. binding posts (par. 30).

c. Turn the circuit selector switch to the R and R x 1 position.

d. Operate the GENERATOR switch in the EXTERNAL position.

e. Adjust the LRC dial to read 1.00.

f. Adjust the LRC DIAL MULTIPLIER for minimum signal (widest shadow) on the electron ray tube. Alternately adjust the LRC dial and the audio oscillator frequency for the best null.

g. Read the resonant frequency of the tuned circuit or inductor from the TS-382/U.

### **38. Measurement of Dissipation Factor and Storage Factor at Frequencies Other than 1,000 Cps**

a. *General.* The calibration of the LRC dial is independent of the frequency used in making measurements. Dissipation factor and storage factor depend on frequency. *The Q and D-Q scales can be read directly only at 1,000 cps* (the frequency of the internal oscillator); therefore, all dissipation or storage factor readings on the black D-Q scale (par. 26j, example 1) must be multiplied by the test frequency, in kc (kilocycles), to obtain the correct values of Q or D. Storage factor readings on the red Q scale (par. 26j, example 2) must be divided by the frequency, in kc (1,000 cps equals 1 kc), to obtain the correct values. At frequencies lower than 1 kc, the Q and D-Q scales do not overlap and the D and Q range must be extended (b below). At frequencies higher than 1 kc, the ranges of the variable resistors are more than sufficient to overlap.

b. *Extending D and Q Range of Q and D-Q Dial.*

(1) Connect Decade Resistor TS-679A/U to the EXT. D-Q binding posts (par. 16) to extend the range of the bridge resistors and provide sufficient resistance for the overlapping of ranges on the D-Q and Q scales when dissipation factor and storage factor are measured at frequencies below 10 kc.

(2) For storage factors below 10, connect the external resistance between the C (high) binding post and any binding post marked G. Short the EXT. D-Q binding posts. Set the Q and D-Q dial at 0, and set the circuit selector switch to L and Q x 100 position.

*Note.* The resistance values required for given values of dissipation factor and storage factor at typical frequencies are given in the table below. The values shown are the total resistance in series or series-parallel

with standard capacitor C2 in bridge arm B (fig. 21, 22 and 23).

Typical measuring frequencies (kc)	Resistance (k $\Omega$ /a)			
	When D=1 C and D-Q x .01)	When D=1 C and D-Q x 0.1)	When Q=10 or more (L and Q x 100)	When Q=10 or less (L and Q x 100)
.10	1.592	15.920	1.592	159.20 <sup>b</sup>
.20	.796	7.960	.796	79.60
.50	.318	3.184	.318	31.840
2.00	.080	.796	.080	7.960
5.00	.032	.318	.032	3.184
10.00	.016	.160	.016	1.592

\*The formula for calculating the proper resistance value when measuring Q is:  $R (k\Omega) = 1.592/Qf (kc)$ .

<sup>b</sup>The formula for calculating the proper resistance value when measuring D is:  $R (k\Omega) = 1.592 D/f (kc)$ . This resistance is not available in the TS-679A/U.

*c. Measuring Dissipation Factor at Frequencies Below 1 Kc.*  
Although the ranges of the Q and D-Q dial do not overlap below 1 kc, the dissipation factor of the unknown capacitor often will lie within the limited range of the bridge resistors. If a null can be obtained, multiply the black D-Q scale reading by the frequency, in kc, to obtain the correct dissipation factor (0). If a null cannot be obtained, proceed as follows:

- (1) Connect Audio Oscillator TS-382/U to the EXT. GEN. binding posts (par. 30). Remove the shorting bar and connect Decade Resistor TS-679A/U to the EXT. D-Q binding posts. Refer to the applicable column of the table in *b* above to determine the necessary maximum resistance for the setting of the TS-679A/U. Connect the unknown capacitor to the C binding posts with the shield or outside foil connected to the LO binding post.
- (2) Make the following switch settings:
  - (a) Turn the circuit selector switch to C and D-Q x .01 or C and D-Q x 0.1 position.
  - (b) Adjust the Q and D-Q dial to 0 on the black scale.
  - (c) Turn the GENERATOR switch to the EXTERNAL position.
  - (d) Turn the DETECTOR switch to INTERNAL position.
  - (e) Adjust the LRC dial to approximately 1.00.
- (3) Adjust the LRC DIAL MULTIPLIER for a minimum signal on the electron ray tube, and alternately adjust the LRC dial (par. 21*i*) and the TS-679A/U for the best null indication.

- (4) To find the series capacitance ( $C_s$ ) of the unknown capacitor, multiply the LRC dial reading by the reading on the LRC DIAL MULTIPLIER. Read and note the resistance of the TS-679A/U.
- (5) Compute the dissipation factor of the unknown capacitor by the following formula:

$$D = .628fR.$$

where:  $f$  = the frequency in kc.

$R$  = the resistance of the TS-679A/U in kilohms (1,000 ohms equals 1 kilohm).

**Caution:** Be sure to reconnect the shorting bar across the EXT. D-Q binding posts after removing the TS-679A/U.

*d. Measuring Storage Factor at Frequencies Below 1 Kc.*

Although the ranges of the Q and D-Q dial do not overlap below 1 kc, the storage factor of the unknown inductor often will lie within the limited range of the bridge resistors. Try to secure a null with the bridge resistors. If a null can be obtained, multiply the Q reading of the black D-Q scale by the frequency, in kc, to obtain the correct value if the circuit selector switch is in the L and D-Q x 1 positions. Divide the Q reading on the red Q scale by the frequency, in kc, to obtain the correct value if the circuit selector switch is in the L and Q x 100 position. If a null cannot be obtained on either scale, proceed as follows:

- (1) Connect Audio Oscillator TS-382/U to the EXT. GEN. binding posts (par. 30). Remove the shorting bar and connect Decade Resistor TS-679A/U to the EXT. D-Q binding posts. Refer to the applicable column of the table in *b* above to determine the maximum resistance necessary for the Maxwell inductance bridge (fig. 22). This bridge circuit is used for inductors that have a storage factor below 10. Connect the unknown inductor to the L and R binding posts with the shield (if any) connected to the LO binding post.
- (2) Make the following switch settings:
  - (a) Turn the circuit selector switch to the L and Q x 100 position.
  - (b) Adjust the Q and D-Q dial to 10.5 on the black side.
  - (c) Turn the GENERATOR switch to the EXTERNAL position.
- (d) Turn the DETECTOR switch to the INTERNAL position.
- (e) Adjust the LRC dial to approximately 1.00.

- (3) Adjust the LRC DIAL MULTIPLIER for a minimum signal on the electron ray tube, and alternately adjust the LRC dial (par. 21*i*) and the TS-679A/U for the best null indication.
- (4) Find the inductance of the unknown inductor by multiplying the LRC dial reading by the reading of the LRC DIAL MULTIPLIER. This inductance is parallel inductance ( $L_p$ ) when the TS-679A/U is connected to the EXT. D-Q binding posts.

*Note.* Series inductance ( $L_s$ ) can be measured by connecting the TS-679A/U between the red C (high) binding post and any G binding post. EXT. D-Q binding posts must be shorted.

- (5) Read and note the resistance of the external variable resistor.
- (6) Compute the storage factor of the unknown inductor by using one of the following formulas:

If the external variable resistor is connected between the EXT. D-Q binding posts:

$$Q = 1.592/fR$$

If the external variable resistor is connected between the C (high) and G binding posts:

$$Q = .628fR$$

where:  $f$  = the frequency in kc.

$R$  = the resistance of the TS-679A/U in kilohms (1,000 ohms equals 1 kilohm).

*e. Measuring Dissipation Factor or Storage Factor at Frequencies Above 1 Kc.* Dissipation factor and storage factor balances above 1 kc can be obtained through the normal operating procedure (par. 23 and 26) by using the Q and D-Q dial. The range is more than sufficient to overlap at frequencies above 1 kc. All dissipation factor and storage factor readings from the black D-Q scale must be multiplied by the frequency, in kc, to obtain the correct values (par. 26*j*, example 1). All storage factor readings from the red Q scale must be divided by the frequency in kc to obtain the correct values (par. 26*j*, example 2).

### 39. Using LRC Dial as Calibrated Resistor

- a.* Operate the circuit selector switch to any L or R setting.
- b.* Remove all connections from the binding posts.
- c.* Turn the DETECTOR switch to the EXTERNAL position.
- d.* Turn the GENERATOR switch to the INTERNAL POWER OFF position.

e. Connect the test leads to the red L and R binding post and any binding post marked G. (Figures 20, 22, and 23 show that the LRC dial is available as a calibrated resistor.)

f. Multiply the LRC dial calibrations by 1,000 to read their resistance in ohms.

**Caution:** When using the LRC dial as a calibrated resistor, do not allow more than 23 ma to flow through it. Higher currents will damage the resistors and rheostat.

#### 40. Using Resistors of Ratio Arm A as Precision Resistors

a. Turn the circuit selector switch to L and Q x 100 position.

b. Turn the GENERATOR switch to INTERNAL POWER OFF position.

c. Turn the DETECTOR switch to the EXTERNAL position.

d. Make connections to ratio arm A at the C binding posts.

e. Read the resistance from the R scale of the LRC DIAL MULTIPLIER. Seven values of resistance are available for use. Determine the resistance in ohms by multiplying the reading of the R scale of the LRC DIAL MULTIPLIER by 10. The circuit diagram, figure 23, shows the relationship of the C binding posts to ratio arm A.

#### 41. Using Bridge Capacitor as Secondary Capacitance Standard

a. Operate the circuit selector switch to either the C and D-Q x .01 or C and D-Q x 0.1 positions.

b. Turn the GENERATOR switch to the INTERNAL POWER OFF position.

c. Turn the DETECTOR switch to the EXTERNAL position.

d. Adjust the Q and D-Q dial to 0 on the black (D-Q) scale.

e. Connect the test leads to the red C (high) binding post and to any binding post marked G. (Figure 21 shows that the .1 uf capacitor is available as a standard capacitor.) The capacitance between the red C binding post and any G binding post is .1000 uf, plus or minus .25 per cent at 1,000 cps and 25° C. The temperature coefficient of the capacitor is less than plus .01 per cent per degree centigrade between 15° and 60° C. With the Q and D-Q dial set at 0, the dissipation factor of the .1 uf capacitor is approximately .0005.

f. If desired, known dissipation factors can be introduced in the bridge capacitor when the circuit selector is set in the C and D-Q x .01 position by turning the Q and D-Q dial and reading the dissipation factor from the black scale.

**Caution:** Do not apply more than 350 volts to the capacitor at frequencies up to 20 kc. Above 20 kc, the allowable voltage decreases and is inversely proportional to the square root of the frequency.

#### 42. Using Internal Oscillator as External 1,000 Cps Signal Generator

- a. Turn the circuit selector switch to either the C and D-Q x .01 or C and D-Q x 0.1 position.
- b. Turn the LRC DIAL MULTIPLIER to the 0.1 uf position on the C scale.
- c. Turn the GENERATOR switch to the INTERNAL position.
- d. Turn the DETECTOR switch to the EXTERNAL position.
- e. Move the OSC. GAIN control to the ON position.
- f. Remove shorting bar from the EXT. D-Q binding posts.
- g. The output of the internal 1,000 cps, excitation voltage is available at the red L and R (high) and red C (high) binding posts. The frequency is 1,000 cps, plus or minus 1 per cent. The power available is approximately .48 watt across 300 ohms, at 12 volts.

#### 43. Use of Bridge Galvanometer for Measurement of Small Dc Currents

- a. Turn the circuit selector switch to L and Q x 100 position.
- b. Turn the GENERATOR switch to INTERNAL POWER OFF position.
- c. Turn the DETECTOR switch to the METER position.
- d. The galvanometer is now available at any binding post marked G and either the L or C binding posts marked LO. With the DETECTOR switch in the METER position, the sensitivity of the meter is approximately 125 to 0 to 125 microamperes dc. With the METER SHUNT switch depressed and held, the sensitivity of the meter is approximately 7.5 to 0 to 7.5 microamperes dc.

**Caution:** Make sure that the current through the galvanometer does not exceed 125 microamperes dc before connecting the meter to the external circuit. If the current is unknown, connect the external test circuit between the C (high) binding post and any binding post marked G. Set the LRC DIAL MULTIPLIER to the 100k $\Omega$  position on the R scale. This places the 1-megohm resistor in series with the galvanometer as a protective resistor. Turn the LRC DIAL MULTIPLIER counterclockwise one step at a time to place lower values of resistance in series with the galvanometer if the meter needle does not deflect off scale.



#### **44. Stopping Procedure**

- a.* Turn the **GENERATOR** switch to the **INTERNAL POWER OFF** position.
- b.* Turn the **DETECTOR** switch to the **EXTERNAL** position.
- c.* Move the **OSC. GAIN** control to the **OFF** position.
- d.* Move the **POWER** switch to the **OFF** position.
- e.* Remove any exterior connections from the test set such as test leads, headset, or components that have been used to make measurements.
- f.* Move galvanometer clamp in the direction of the arrow.

## CHAPTER 4

### ORGANIZATIONAL MAINTENANCE

*Organizational maintenance is defined as those maintenance procedures performed at first and second echelon. First echelon maintenance is operator's maintenance; second echelon maintenance is repairman's maintenance.*

---

#### Section I. OPERATOR'S MAINTENANCE

##### 45. Scope of First Echelon Maintenance

Operator's maintenance of the AN/URM-90 consists only of performing the preventive maintenance procedures given in paragraph 47. Do not remove any parts of, or make any repairs to the test set.

##### 46. Materials Required

No tools or test equipment are required for operator's maintenance. However, a clean lint-free cloth is required for cleaning the test set.

##### 47. Operator's Preventive Maintenance

*a. Use of DA Form 11-238 (fig. 13).* DA Form 11-238 is a preventive maintenance check list to be used by the operator as directed by his commander. Items not applicable to the test set are lined out. References in the ITEM block in figure 13 are to paragraphs in this manual that contain additional maintenance information pertinent to the particular item.

*b. Daily Preventive Maintenance.*

- (1) Remove dirt and moisture from the external surfaces of the test set, such as the case, case cover, and front panel. On the front panel, clean the galvanometer glass, pilot lamp jewel, electron ray tube, control knobs, switches, and dials. Use a clean, dry, lint-free cloth for dusting and removing moisture. When dirt cannot be easily removed by dusting, moisten the cloth, clean, and then wipe dry with a dry cloth.

**OPERATOR FIRST ECHELON MAINTENANCE CHECK LIST FOR SIGNAL CORPS EQUIPMENT**  
 RADIO COMMUNICATION, DIRECTION FINDING, CARRIER, RADAR

INSTRUCTIONS: See also form 1148

EQUIPMENT IDENTIFICATION <b>AN/URM-90</b>	EQUIPMENT SERIAL NO.
LABOUR FOR MAINTENANCE CONDITIONS: <input checked="" type="checkbox"/> Satisfactory; <input type="checkbox"/> Adjustment, repair or replacement required; <input type="checkbox"/> Defect corrected. NOTE: Strike out items not applicable.	

DAILY		CONDITION						
NO.	ITEM	S	M	T	W	T	F	
1	COMPLETENESS AND GENERAL CONDITION OF EQUIPMENT (connections, connections, carrying cases, wire and cable, accessories, tubes, spare parts, technical manuals and accessories). PAR 10B	<input checked="" type="checkbox"/>						
2	CLEAN AND UNOBTAINED - SUITABLE FOR NORMAL OPERATION							
3	CLEAN BIRT AND MOISTURE FROM METERS, SWITCHES, REARERS, SUBSTANCES, KEYS, JACKS, PLUGS, HEADPHONES, MICROPHONES, SPEAKERS, AND COMPONENT PARTS. PAR 47D(1)	<input checked="" type="checkbox"/>						
4	INSPECT CONTROLS FOR BINDING, SCRAPING, EXCESSIVE LOOSENESS, MISALIGNMENT, POSITIVE ACTION. PAR 47D(2)	<input checked="" type="checkbox"/>						
5	CHECK FOR NORMAL OPERATION. PAR 47D(3)	<input checked="" type="checkbox"/>						

WEEKLY		NO.	ITEM	NO.	ITEM
1	INSPECT CASES, METERS AND EXPOSED METAL SURFACES, FOR RUST, CORROSION, AND MOISTURE. PAR 47C(1)	17	INSPECT CORDS, SWITCHES AND CABLES FOR CUTS, BREAKS, FRAYING, DETERIORATION, KINKS, AND STRAINS. PAR 47C(2)	18	INSPECT METERS FOR DAMAGED GLASS AND CASES. PAR 47C(3)
2	INSPECT CORDS, SWITCHES AND CABLES FOR CUTS, BREAKS, FRAYING, DETERIORATION, KINKS, AND STRAINS. PAR 47C(2)	19	INSPECT FOR LOOSENESS OF ACCESSIBLE ITEMS, SWITCHES, KEYS, JACKS, MICROPHONES, SPEAKERS, HEADPHONES, EARPLUGS, AND PILOT LIGHT ASSEMBLIES. PAR 47D(4)	20	IF DEFICIENCIES NOTED ARE NOT CORRECTED DURING INSPECTION, INDICATE ACTION TAKEN FOR CORRECTION.

DA FORM 11-238  
 1 MAY 51

REPLACES DA AGO FORM 419, 1 DEC 50, WHICH IS OBSOLETE.

TM2646A-14

Figure 13. DA Form 11-238, prepared for use with Capacitance-Inductance-Resistance Test Set AN/URM-90.

- (2) Carefully inspect controls, dials, and switches for binding, scraping, excessive looseness, and for positive action.
  - (3) Check the test set for normal operation (par. 18, 23, and 26).
  - (4) Report any troubles to a higher maintenance authority.
- c. *Weekly Preventive Maintenance.* Perform the daily preven-

tive maintenance procedures (*b* above) and also perform the following weekly inspections:

- (1) Inspect exposed metal surfaces of the case for moisture and evidences of rust and corrosion.
- (2) Inspect the power cable and the red and black test leads for breaks, deterioration, and loose connectors.
- (3) Inspect the galvanometer for damaged case and broken glass.

## **Section II. REPAIRMAN'S MAINTENANCE**

### **48. Scope of Repairman's Maintenance**

*a.* Following is a list of maintenance duties performed by the unit repairman. The scope of these duties has been determined by the normally available tools, materials, test equipment, and parts and by the Military Occupational Specialty of the repairman (field radio repairman).

*b.* Repairman's maintenance for the test set consists of the following:

- (1) Repairman's preventive maintenance (par. 51).
- (2) Repair of defective test leads, power cords, and resoldering disconnected wiring if reconnection is obvious.
- (3) Replacement and testing of defective tubes (par. 54).
- (4) Replacement of defective fuses and pilot lamp (par. 57 and 58).
- (5) Trouble shooting using equipment performance check list (par. 55 and 56).

*Note.* No lubrication of the test set is required.

### **49. Additional Tools, Test Equipment, and Materials Required**

The following tools, test equipment, and materials are not supplied as a part of the test set but are required for organizational maintenance.

*a. Tools.* Tool Equipment TK-21/G contains all the necessary equipment for repairing the AN/URM-90 at an organizational level.

*b. Test Equipment.*

Electron Tube Test Set TV-7/U (TM 11-5083)

Multimeter TS-297/U (TM 11-5500)

*c. Materials.*

Lint-free cloth

Cleaning solvent (4-ounce can, Federal stock No. 6G236.1)

## 50. Special Tools Supplied with Equipment

Two Allen set screw wrenches No. 8 and two Allen set screw wrenches No. 10 are supplied with the test set for tightening and loosening the set screws in the control knobs on the front panel. The wrenches are also used to remove and replace the set screws from the Q and D-Q dial assembly, LRC DIAL MULTIPLIER assembly, and circuit selector switch assembly.

## 51. Repairman's Preventive Maintenance

*a. Use of DA Form 11-239* (fig. 14). DA Form 11-239 is a preventive maintenance check list to be used by the repairman. Items not applicable to the test set are lined out. References in the ITEM block are to paragraphs in this manual that contain additional maintenance information pertinent to the particular item.

### *b. Monthly Checks.*

- (1) Perform the checks listed in paragraph 47c.
- (2) Remove the bridge chassis from the case by loosening the four captive screws that hold the bridge chassis to the case (fig. 15). Pull out the bridge chassis by grasping two of the captive screws, located diagonally across the panel in opposite corners of the bridge, and pulling the bridge chassis out of the case.
- (3) Clean switches, terminal boards, and interior of chassis not readily accessible. Use a clean, dry, lint-free cloth. Use cleaning solvent to clean contacts or dirt not easily removed.
- (4) Inspect internal electrical components for cracks, chipping, blistering, discoloration and moisture.
- (5) Inspect fixed capacitors for leaks, bulges, and discoloration.
- (6) Check terminals of large fixed capacitors and resistors for corrosion, dirt, and loose connections.
- (7) Inspect connections to transformers, rheostats, and potentiometers for loose connections.
- (8) Inspect seating, mounting, and set screws of all components for looseness. Tighten any loose screws or reseal loose tubes or fuses.
- (9) Check all connections for moisture-fungiproofing.
- (10) Check the wipers of all rheostats and potentiometers for good contact. If any wiper is not making good contact, do not attempt repairs. Turn in the equipment to a higher maintenance authority.

**SECOND AND THIRD ECHELON MAINTENANCE CHECK LIST FOR SIGNAL CORPS EQUIPMENT**  
**RADIO COMMUNICATION, DIRECTION FINDING, CARRIER, RADAR**

INSTRUCTIONS: See other side			
EQUIPMENT NOMENCLATURE <b>AN/URM-90</b>	EQUIPMENT SERIAL NO.		
LOOKUP FOR MARKING CONDITIONS: <input checked="" type="checkbox"/> Satisfactory; <input type="checkbox"/> Adjustment, repair or replacement required; <input type="checkbox"/> Defect corrected. NOTE: Strike out items not applicable.			
NO.	ITEM	NO.	ITEM
1	COMPLETENESS AND GENERAL CONDITION OF EQUIPMENT (connections, connections, carrying case, wire and cable, adaptability, tubes, spare parts, technical manuals and accessories). <b>PAR. 100</b>	19	ELECTRON TUBES - INSPECT FOR LOOSE ENVELOPES, CAP CONNECTIONS, CRACKED SOCKETS; INSUFFICIENT SOCKET SPRING TENSION; CLEAN DIRT AND DIRT CAREFULLY; CHECK CONDITION OF RECEIVER TUBE TUBES. <b>PAR. 91 AND 94</b>
2	<del>COMPLETELY CLEAN AND DRY; INSPECT FOR CORROSION AND DISCOLORATION.</del>	20	<del>INSPECT FOR CORROSION AND DISCOLORATION.</del>
3	CLEAN DIRT AND MOISTURE FROM SURFACES (connections, connections, JACS, PLUGS, ROADWAYS, CONNECTIONS, COMPONENT PANELS). <b>PAR. 51 B (1)</b>	21	INSPECT FIXED CAPACITORS FOR LEADS, BOLTS, AND DISCOLORATION. <b>PAR. 51 B (2)</b>
4	INSPECT SEATING OF READILY ACCESSIBLE "PLUG-OUT" ITEMS: TUBES, LIGHT, SWITCHES, FUSES, COMPONENTS. <b>PAR. 51 B (3)</b>	22	<del>INSPECT FOR CORROSION AND DISCOLORATION.</del>
5	INSPECT CONTROLS FOR BINDING, SCRAPPING, EXCESSIVE LOOSENESS, MISALIGNMENT, POSITIVE ACTION. <b>PAR. 47 B (2)</b>	23	<del>INSPECT FOR CORROSION AND DISCOLORATION.</del>
6	CHECK FOR NORMAL OPERATION. <b>PAR. 47 B (3)</b>	24	INSPECT RESISTORS, BUSHINGS, AND INSULATORS, FOR CRACKS, CHIPPING, BLISTERING, DISCOLORATION AND MOISTURE. <b>PAR. 51 B (4)</b>
7	<del>INSPECT FOR CORROSION AND DISCOLORATION.</del>	25	INSPECT TERMINALS OF LARGE FIXED CAPACITORS AND RESISTORS FOR CORROSION, DIRT AND LOOSE CONTACTS. <b>PAR. 51 B (5)</b>
8	INSPECT CASES, CONNECTIONS, AND EXPOSED METAL SURFACES, FOR RUST, CORROSION, AND MOISTURE. <b>PAR. 47 C (1)</b>	26	CLEAN AND TIGHTEN SWITCHES, TERMINAL BLOCKS, PLUGS, CONNECTIONS, AND INTERIORS OF CHASSIS AND CABINETS NOT READILY ACCESSIBLE. <b>PAR. 51 B (6) AND (10)</b>
9	INSPECT CORD, CABLE, WIRE, AND CABLE-BINDING FOR CUTS, BREAMS, FRAYING, DETRIORATION, KINKS, AND STRAINS. <b>PAR. 47 C (2)</b>	27	INSPECT TERMINAL BLOCKS FOR LOOSE CONNECTIONS, CRACKS AND BREAKS. <b>PAR. 51 B (7)</b>
10	<del>INSPECT FOR CORROSION AND DISCOLORATION.</del>	28	<del>INSPECT FOR CORROSION AND DISCOLORATION.</del>
11	<del>INSPECT FOR CORROSION AND DISCOLORATION.</del>	29	<del>INSPECT FOR CORROSION AND DISCOLORATION.</del>
12	INSPECT FOR LOOSENESS OF ACCESSIBLE ITEMS: SWITCHES, HOOPS, JACKS, CONNECTORS, ELECTRICAL TRANSFORMERS, CAPACITORS, AND FLIGHT ASSEMBLIES. <b>PAR. 51 B (8)</b>	30	<del>INSPECT FOR CORROSION AND DISCOLORATION.</del>
13	<del>INSPECT FOR CORROSION AND DISCOLORATION.</del>	31	CLEAN AND TIGHTEN CONNECTIONS AND MOUNTINGS FOR TRANSFORMERS, COILS, POTENTIOMETERS, AND RHEOSTATS. <b>PAR. 51 B (7) AND (10)</b>
14	<del>INSPECT FOR CORROSION AND DISCOLORATION.</del>	32	<del>INSPECT FOR CORROSION AND DISCOLORATION.</del>
15	INSPECT METERS FOR DAMAGED GLASS AND CASES. <b>PAR. 47 C (3)</b>	33	<del>INSPECT FOR CORROSION AND DISCOLORATION.</del>
16	<del>INSPECT FOR CORROSION AND DISCOLORATION.</del>	34	<del>INSPECT FOR CORROSION AND DISCOLORATION.</del>
17	<del>INSPECT FOR CORROSION AND DISCOLORATION.</del>	35	<del>INSPECT FOR CORROSION AND DISCOLORATION.</del>
18	<del>INSPECT FOR CORROSION AND DISCOLORATION.</del>	36	<del>INSPECT FOR CORROSION AND DISCOLORATION.</del>
19	<del>INSPECT FOR CORROSION AND DISCOLORATION.</del>	37	MOISTURE AND FUNGUSPROOF. <b>PAR. 51 B (9)</b>
IF DEFICIENCIES NOTED ARE NOT CORRECTED DURING INSPECTION, INDICATE ACTION TAKEN FOR CORRECTION.			

**DA FORM 11-239**

REPLACES DA AGO FORM 119, 1 DEC 50, WHICH IS OBSOLETE.

16-55000-1

TM2646A-15

Figure 14. DA Form 11-239, prepared for use with Capacitance-Inductance-Resistance Test Set AN/URM-90.

- (11) Replace the bridge chassis in the case and tighten the four captive screws (figure 15).
- (12) Perform an operational check as outlined in paragraph 56. Note any abnormal indications and apply the recommended *corrective measures* when required to restore normal operation.

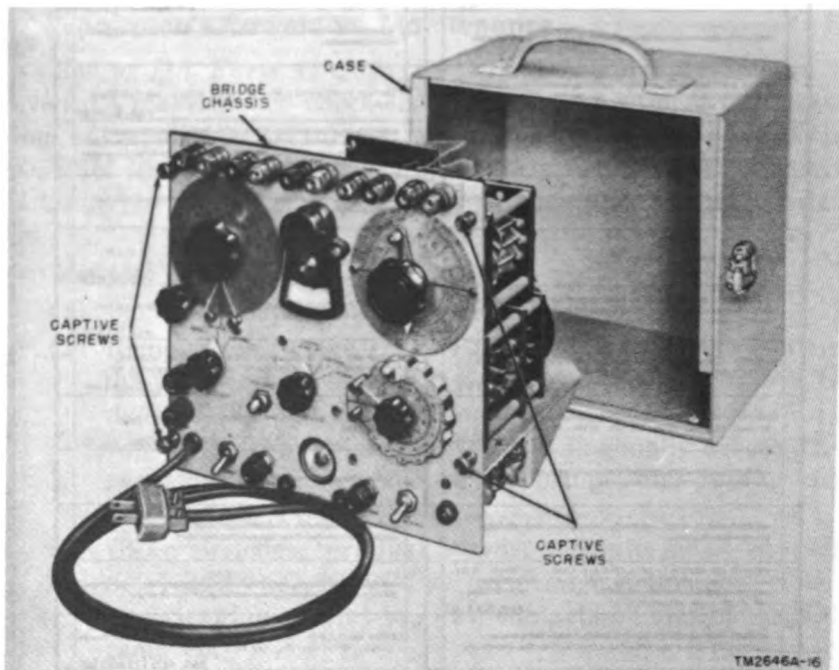

Figure 15. Bridge chassis, removed from case.

## 52. Repairman's Trouble-shooting Techniques

The trouble shooting and repair work that can be performed by the repairman is necessarily limited by the tools, test equipment, and replaceable parts issued, and by the existing tactical situation. Accordingly, trouble shooting is based on operational checks and the use of the senses in determining troubles, such as burned-out fuses, broken cords, defective tubes, cracked insulators, internal grounding, and short circuits. Multimeter TS-297/U is also used to check continuity of conductors suspected of being broken and to measure voltages that are suspected of being more or less than the prescribed input value of approximately 115 volts ac. Electron Tube Test Set TV-7/U is used by the repairman to test tubes suspected of being faulty. The procedures outlined are to assist

the repairman in locating the fault and determining whether repair at organizational level is possible or repair at field maintenance level is indicated. If the fault cannot be determined through the procedures outlined in paragraphs 53 through 56, trouble shooting at field maintenance level is required.

### **53. Visual Inspection**

*a.* When failure is encountered and the cause is not immediately apparent, check as many of the items listed in *b* below as is practicable before starting a systematic operational check of the equipment. Do not, however, remove the chassis from the case and begin this check without some knowledge of the operational symptoms. If possible, obtain information from the operator of the equipment regarding performance at the time trouble occurred.

*b.* Complete or partial failure of the test set may be caused by one or more of the following faults, which can be checked by visual inspection:

- (1) Check for worn, broken, or disconnected cords or plugs. If a fault is suspected, check for continuity with the TS-297/U.
- (2) Fuses can be checked for continuity with the TS-297/U.
- (3) Check for broken or loose wires in the bridge chassis.
- (4) All tubes should be lighted when the POWER switch is turned ON and the GENERATOR switch is in the INTERNAL position. Test suspected faulty tubes (par. 54).
- (5) Overheated capacitors can be detected by sight and smell.
- (6) Burned resistors and insulation will be discolored and may indicate a possible short or ground.
- (7) Improper positioning of controls during operation will provide erratic test set operation.

### **54. Trouble-shooting and Replacing Faulty Tubes**

*a.* Many tubes are discarded before their effective life expires. The effective life of tubes can be prolonged by observing the following precautions:

- (1) Inspect all wiring and general condition of the test set before removing tubes.
- (2) Isolate the trouble, if possible, to a particular section of the test set circuit.
- (3) If Electron Tube Test Set TV-7/U is available, remove and test one tube at a time. Substitute new tubes only for those that are defective.



(4) If a tube tester is not available, trouble shoot by the following tube substitution method.

(a) Replace the suspected tubes (fig. 16), one at a time, with new tubes. Note the sockets from which the original tubes were removed. If the equipment becomes operative, discard the last tube removed.

(b) Reinsert the remaining original tubes, one at a time, in the original sockets. If equipment failure occurs during this step, discard the last original tube. *Do not leave a new tube in a socket if the equipment operates with the original tube.*

*Note.* If a replacement for a bad tube soon becomes defective, check condition of component parts of the tube circuit. Otherwise, continued tube replacement will effect only temporary repair and more serious troubles may result.

b. If tube substitution does not correct the trouble, *reinsert the original tubes in their original sockets* before forwarding the defective equipment for higher echelon repair.

c. Discard tubes when tube testers show that the tubes are defective. Tubes may be discarded when the tube defect is obvious; for example, a broken envelope or a broken filament.

(1) Do not discard tubes merely because they have been used for a specified length of time. Satisfactory operation in a circuit is the final proof of tube quality. The tube in use may work better than a new one.

(2) Do not discard tubes merely because they fall on or slightly above the minimum acceptable value when checked in the tube tester (TV-7/U). A certain percentage of new tubes fall near the low end of their acceptable range of tube specification and therefore start their operational life at a value close to the tube tester retention limit. These tubes may provide satisfactory performance throughout a long period of operational life at this *near limit* value.

d. Be careful when withdrawing miniature tubes (V1 and V3) from their sockets. Do not rock or rotate the top of a miniature tube when removing it. Pull the tube straight out. The external pin and the wire lead sealed in the glass base are two different metals that are butt-welded together where the pin appears to enter the glass. Rocking or rotating the tube causes bending, which may break this weld or cause a resistance or intermittent joint to develop.

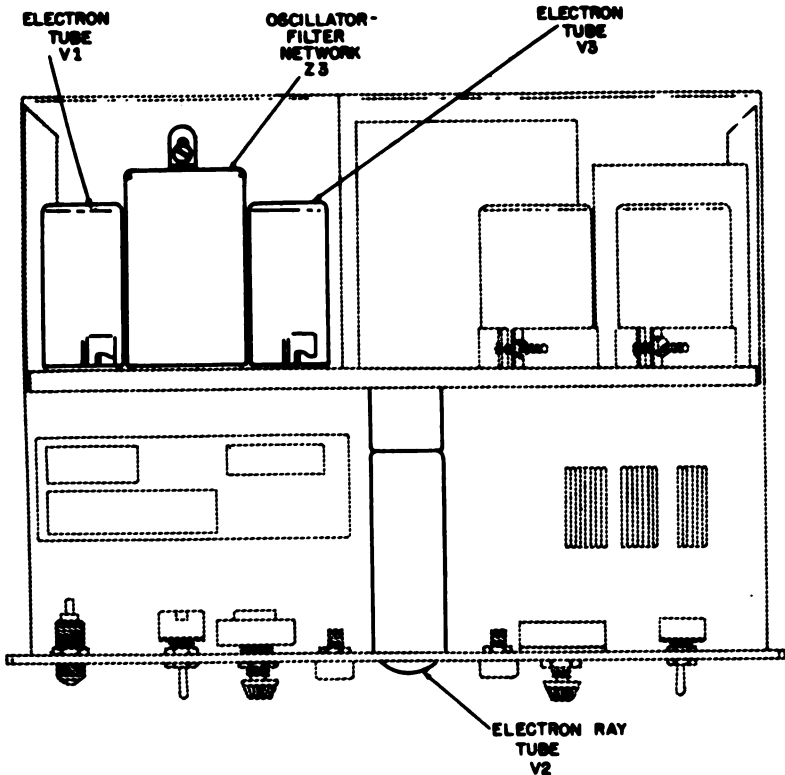

TME846A-17

Figure 16. Bridge chassis, showing tube location.

## 55. Trouble shooting Using Equipment Performance Check List

*a. General.* The equipment performance check list (par. 56) will assist the repairman in locating trouble in the test set. These lists are provided in three parts, because the three primary measurements have different trouble indications. When trouble shooting by using the equipment performance check list, ask the operator of the equipment whether he was testing for inductance, capacitance, or resistance and use the proper operational test (par. 56a, b, or c). These check lists provide the item to be checked, the conditions under which the item is checked, the normal indications and tolerances or correct operation, and the corrective measures the operator can take. *To use these lists, follow the items in numerical sequence.*

*b. Action or Condition.* For some items, the information given in the *Action or condition* column consists of various switch and

control settings under which the item is to be checked. For other items it represents an action that must be taken to check the normal indication given in the *Normal indications* column.

*c. Normal Indications.* The normal indications listed include the visible and audible signs that the operator should perceive when he checks the items. If the indications are not normal, the repairman should apply the recommended corrective measures.

*d. Corrective Measures.* This column indicates the action to be taken by the unit repairman if the normal indication is not obtained. Second echelon maintenance personnel are restricted to performing only the maintenance for which they are provided tools, test equipment, and replacement parts. References to paragraphs in this chapter indicate repairs to be made by the unit repairman. References to paragraphs in chapter 6 are for use by field maintenance personnel *only*.

## 56. Equipment Performance Check List

### a. Resistance Measurements.

Item No.	Item	Action or condition	Normal indications	Corrective measures
1	POWER switch	Move to OFF position.		
2	Line cord	Connect to 115-volt, single-phase, 50- to 1,000-cps power source.		
3	DETECTOR switch	Turn to METER position.		
4	GENERATOR switch	Turn to INTERNAL POWER OFF position.		
5	EXT. D-Q binding posts	Short with shorting bar.		
6	Circuit selector switch	Turn to R and R x 1 position.		
7	LRC DIAL MULTIPLIER	Turn to .01 position on the R scale.		
8	LRC dial	Turn to 1.00 position.		
9	L and R binding posts	Connect resistor to be measured to L and R binding posts.		
10	Galvanometer	Move clamp toward meter scale.	Meter needle should be centered at zero.	Adjust needle with galvanometer zero adjustment knob (par. 18a).

P R E P A R A T O R Y

Item No.	Item	Action or condition	Normal indications	Corrective measures
11	POWER switch	Move to ON position.	Pilot lamp lights.	Check power cord and plug (par. 53b(1)). Check ac power source. Check fuse F1 (par. 52b(2)). Check pilot lamp (par. 56). Turn in equipment for repair (par. 69, item 1).
12	GENERATOR switch	Turn to DC LO position.		
13	LRC DIAL MULTIPLIER	Turn slowly clockwise.	Galvanometer needle should be on scale with least amount of deflection.	Check galvanometer M1 for bent needle (par. 69, item 4). Check connections to L and R binding posts. Clean switch contacts (par. 50b(3)). Turn in equipment for repair (par. 69, item 8).
14	Circuit selector switch	Turn to R and R x 10 position, if necessary (par. 18f).	Galvanometer needle should be on scale with least amount of deflection.	Clean switch contacts (par. 51b(3)). Turn in equipment for repair (par. 69, item 4).
15	GENERATOR switch	Turn to DC HI position, if necessary (par. 18f).	Galvanometer needle should be on scale with least amount of deflection.	Turn in equipment for repair (par. 69, item 4).
16	METER SHUNT switch	Push and hold switch.	Galvanometer needle deflection should increase.	Turn in equipment for repair (par. 69, item 9).

S  
T  
A  
R  
TE  
Q  
U  
I  
P  
M  
E  
N  
T  
P  
E  
R  
F  
O  
R  
M  
A  
N  
C  
E

17	LRC dial	Turn LRC outer dial, next the middle dial, and last the inner dial.	Zero reading on galvanometer.	Clean switch contacts (par. 51b(3)). Turn in equipment for repair (par. 69, item 7).
18	GENERATOR switch Galvanometer	Turn to INTERNAL POWER OFF position. Move clamp in direction of arrow.	Meter needle will center and hold.	
19	POWER switch	Move to OFF position.	Pilot lamp goes out.	
20	L and R binding posts	Remove resistor under measurements.		
21				

*b. Capacitance Measurements.*

Item No.	Item	Action or condition	Normal indications	Corrective measures
1	Perform steps 1 and 2 of <i>a</i> above.			
2	DETECTOR switch	Turn to INTERNAL position.		
3	GENERATOR switch	Turn to INTERNAL position.		
4	EXT. D-Q binding posts	Short with shorting bar.		
5	Circuit selector switch	Turn to C and D-Q x .01 position.		
6	LRC DIAL MULTIPLIER	Turn to .0001 uf position on C scale.		

	Item No.	Item	Action or condition	Normal indications	Corrective measures
P R E P A R A T O R Y	7	LRC dial	Adjust for reading of 1.00.		
	8	Q and D-Q dial	Turn to midscale.		
	9	C binding posts	Connect capacitor to be measured to C binding posts.		
S T A R T	10	Perform step 11 of <i>a</i> above.			
	11	LRC DIAL MULTIPLIER	Turn slowly counterclockwise (par. 23 <i>h</i> ).	Minimum signal (widest shadow) on electron ray tube.	Check tubes V1, V2, and V3 (par. 53). Clean switch contacts (par. 50 <i>b</i> (3)).
E Q U I P M E N T	12	LRC dial	Turn LRC outer dial, next the middle dial, and last the inner dial (par. 23 <i>h</i> ).	Minimum signal (widest shadow) on electron ray tube.	Turn in equipment for repair (par. 69, item 8). Check tubes V1, V2, and V3 (par. 54). Clean switch contacts (par. 51 <i>b</i> (3)).
	13	Q and D-Q dial	Turn as required (par. 23 <i>h</i> ) in conjunction with LRC dial.	Minimum signal (widest shadow) on electron ray tube.	Turn in equipment for repair (par. 69, item 7). Check tubes V1, V2, and V3 (par. 54). Turn in equipment for repair (par. 69, item 11).
P E R F O R M A N C E					

S	14	Perform steps 18 and 20 in <i>a</i> above	Remove capacitor under measurement.
T O P	15	C binding posts	

*c. Inductance Measurements.*

	Item No.	Item	Action or condition	Normal indications	Corrective measures
P R E P A R A T O R Y	1	Perform steps 1, 2, 3, and 4 of <i>b</i> above	Turn to L and Q x 1 or L and Q x 100 as required (par. 26b).		
	2	Circuit selector switch	Turn to 0.1 mh position on L scale.		
	3	LRC DIAL MULTIPLIER			
	4	Perform steps 7 and 8 of <i>b</i> above			
	5	OSC. GAIN control	Turn clockwise from OFF position.		
	6	AMP. RESPONSE switch	Move to PEAK position.		
	7	L and R binding posts	Connect inductor to be measured to L and R binding posts.		



	Item No.	Item	Action or condition	Normal indications	Corrective measures
S T A R T	8	Perform step 11 of $\alpha$ above			
	9	LRC DIAL MULTIPLIER	Turn slowly clockwise (par. 26i).	Minimum signal (widest shadow) on electron ray tube.	Check tubes V1, V2, and V3 (par. 54). Clean switch contacts (par. 51b(3)). Turn in equipment for repair (par. 69, item 8).
	10	LRC dial	Turn LRC (outer) dial, next the middle dial, and last the inner dial (par. 26i).	Minimum signal (widest shadow) on electron ray tube.	Check tubes V1, V2, and V3 (par. 54). Clean switch contacts (par. 51b(3)). Turn in equipment for repair (par. 69, item 7).
P E R F O R M A N C E	11	Q and D-Q dial	Turn as required (par. 26i).	Minimum signal (widest shadow) on electron ray tube.	Check tubes V1, V2, and V3 (par. 54). Turn in equipment for repair (par. 69, item 11).
	12	Perform steps 18 and 20 in $\alpha$ above			
S T O P	13	L and R binding posts	Remove inductor under measurement.		

## **57. Replacing Pilot Lamp**

*a.* Remove the pilot lamp (fig. 4) by turning the jeweled lamp cover counterclockwise and unscrewing it from the front panel of the bridge. The lamp is located inside the lamp cover.

*b.* Slide the lamp from the lamp cover and replace it with a new one.

*c.* Screw the lamp cover that contains the new lamp into the panel of the bridge by turning it clockwise until the lamp cover is fingertight.

## **58. Fuse Replacement and Location**

*a.* The bridge contains a protective fuse and a spare fuse. The fuses are located on the front panel of the bridge (fig. 4). The protective fuse is marked FUSE, 3 AMPS and the spare fuse is marked FUSE, SPARE. These fuses are 3-ampere, cartridge-type fuses and are mounted in extractor, post-type holders.

*b.* Remove either fuse by rotating the fuse cap  $\frac{1}{4}$ -turn in the direction of the arrow until the fuse cap springs up. Lift up the fuse cap; one end of the fuse will be wedged in the fuse cap.

*c.* Pull the fuse from the fuse cap and replace it with a new 3-ampere, cartridge-type fuse.

*d.* Replace the fuse cap that contains the new fuse in position on the front panel, push down, and twist in a clockwise direction until the fuse cap locks in position.

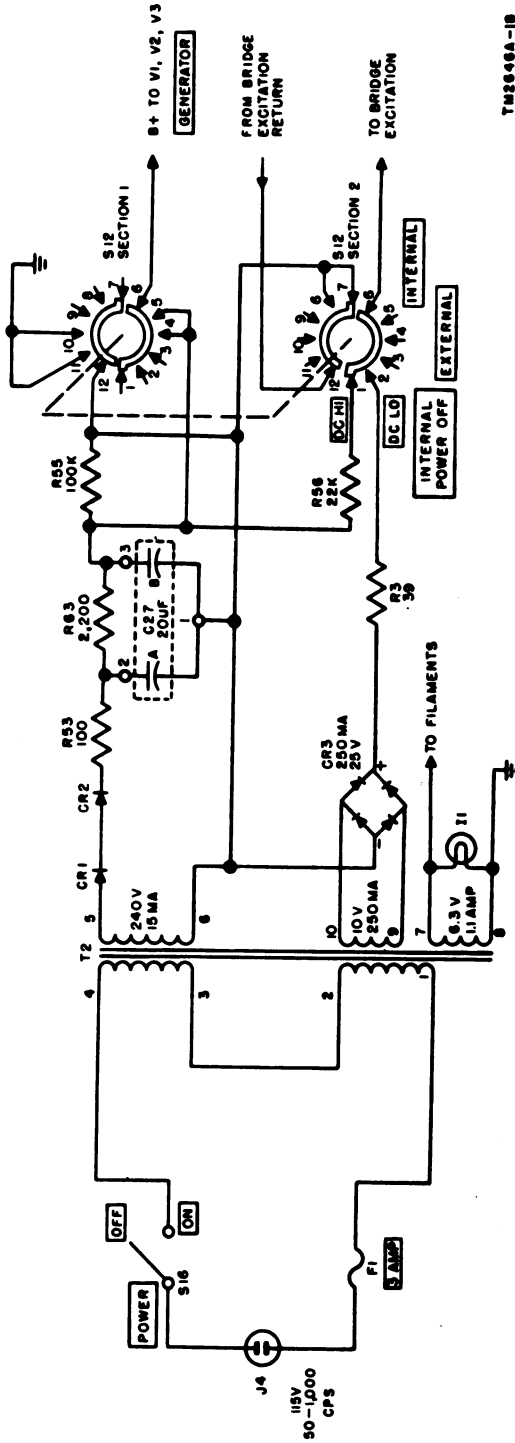

TM2649A-1B

Figure 17. Power supply, simplified schematic diagram.

## CHAPTER 5

### THEORY

*Note.* A thorough knowledge of the operation of this equipment is necessary to understand the theory of the bridge.

---

#### 59. Power Supply Circuit

(fig. 17)

a. The 115-volt ac input voltage is applied from receptacle J4 to the primary (1-4) winding of power transformer T2 through POWER switch S16 and protective fuse F1. Power transformer T2 operates over a frequency range of 50 to 1,000 cps at 115 volts.

b. The high-voltage secondary (5-6) winding of power transformer T2 steps up the line voltage to approximately 240 volts. Half-wave rectification is obtained through series connected selenium rectifiers CR1 and CR2, and filtered by the filter circuit consisting of resistors R53 and R63 and two-section electrolytic capacitor C27. Resistor R55 is the bleeder resistor for the filter network.

c. The low-voltage secondary (9-10) winding of power transformer T2 steps down the line voltage to approximately 10 volts. Full-wave rectification is obtained through bridge rectifier CR3. No filtering is used in the low-voltage power supply.

d. The secondary (7-8) filament winding of power transformer T2 steps down the line voltage to 6.3 volts. The current drain of the filament winding is approximately 1.1 amperes. Terminal 8 of the filament winding is grounded. Terminal 7 is connected directly to the filaments of tubes V1, V2, and V3 (fig. 37). Pilot lamp I 1 is connected directly across the filament winding (fig. 17) and lights when POWER switch S16 is turned to ON. The lamp is covered by a red lens.

e. Section 1 of GENERATOR switch S12 controls the application of B+ plate voltages to tubes V1, V2, and V3. Plate voltage is applied to the three tubes when GENERATOR switch S12 is in either the EXTERNAL or INTERNAL positions through terminals 4 and 5 respectively of section 1. Simultaneously, with the application of plate voltage in these positions, the negative

side of the high-voltage power supply is grounded at contact 10 or 11 on switch S12, section 1.

f. Section 2 of GENERATOR switch S12, in part, controls the distribution of dc high and dc low excitation voltages across the bridge network when measuring resistors. Resistor R56 is a current-limiting resistor, which is switched in series with the bridge when S12 is in the DC HI position. Resistor R3 is a voltage-limiting resistor, which is switched in series with the bridge when S12 is in the DC LO position. Section 2 of GENERATOR switch S12 also functions in the oscillator-amplifier circuit (par. 60d).

## **60. Oscillator-amplifier Circuit**

(fig. 18)

a. Oscillator V1A develops the  $1,000 \pm 10$  cps voltage for bridge excitation when the bridge is used to measure inductors and capacitors. The oscillator frequency is determined by its RC feed-back network (contained in oscillator filter assembly, Z3), which serves as the tuned circuit.

b. During operation, oscillator V1A produces a phase shift of approximately  $180^\circ$  across the RC circuit, and couples this out-of-phase voltage to the grid. This voltage causes oscillations to appear across plate-load resistor R64. These oscillations are sustained at a constant 1,000-cps rate when the tube is conducting normally. Cathode bias for oscillator V1A is obtained through resistor R48 and the C section of three-section bypass capacitor C26.

c. The oscillator output is coupled to oscillator-amplifier V1B through capacitor C24 and resistor R47 and across OSC. GAIN control R66. Cathode bias is provided by cathode-biasing resistor R50. The OSC. GAIN control provides a continuous adjustment for the amplitude of the 1,000-cps voltage. The output of the amplifier from the plate (pin 6) is impressed across the primary of isolation transformer T1. Switch S15 is an integral part of the OSC. GAIN control and, when in the OFF (extreme counter-clockwise) position, disconnects B+ plate voltage from the oscillator-amplifier circuit. If an external oscillator is used, the OSC. GAIN control should be moved to the OFF position to remove any possibility of the extraneous oscillations being developed in the bridge.

d. The oscillator voltage appearing at the secondary of T1 is directly coupled to section 2 of GENERATOR switch S12 across contacts 11 and 5. In the INTERNAL position, the oscillator output is switched directly across the input of the bridge network.

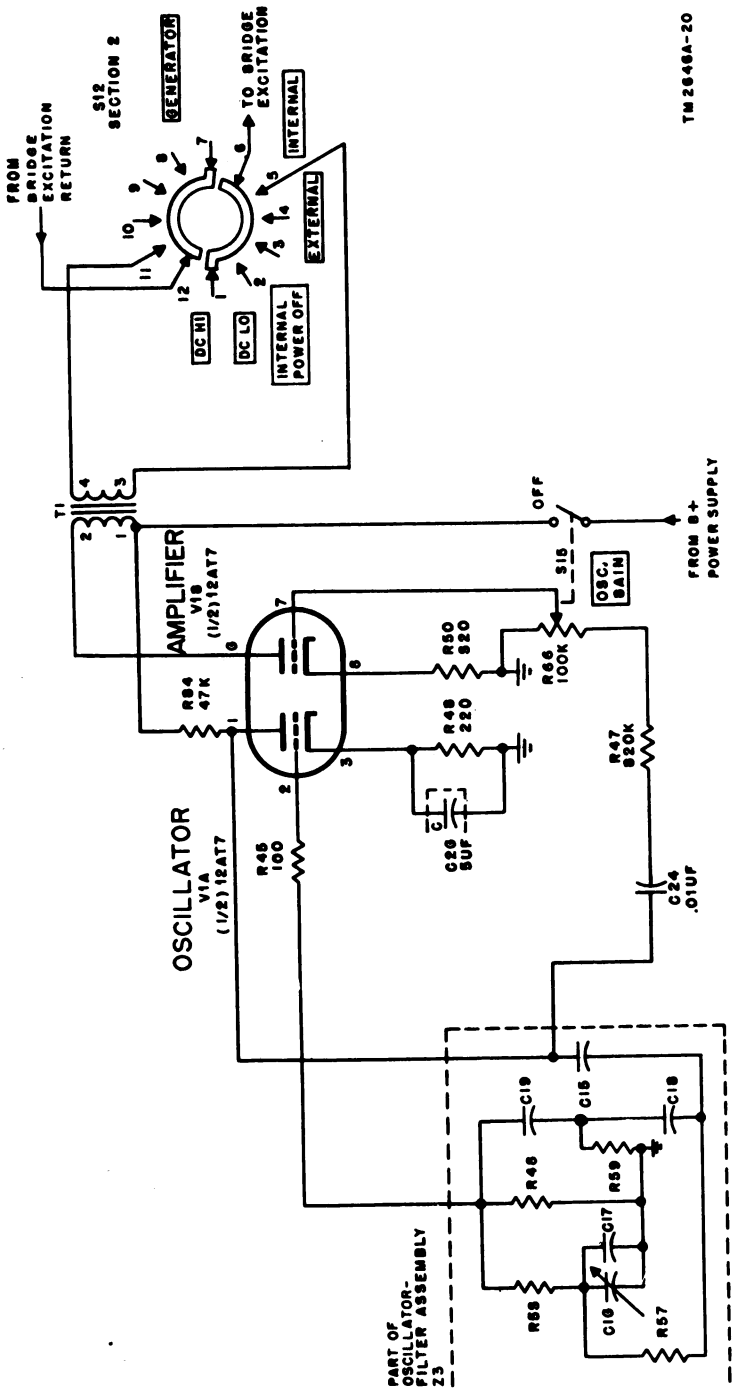

TM 2648A-20

Figure 18. Oscillator-amplifier circuit, simplified schematic diagram.

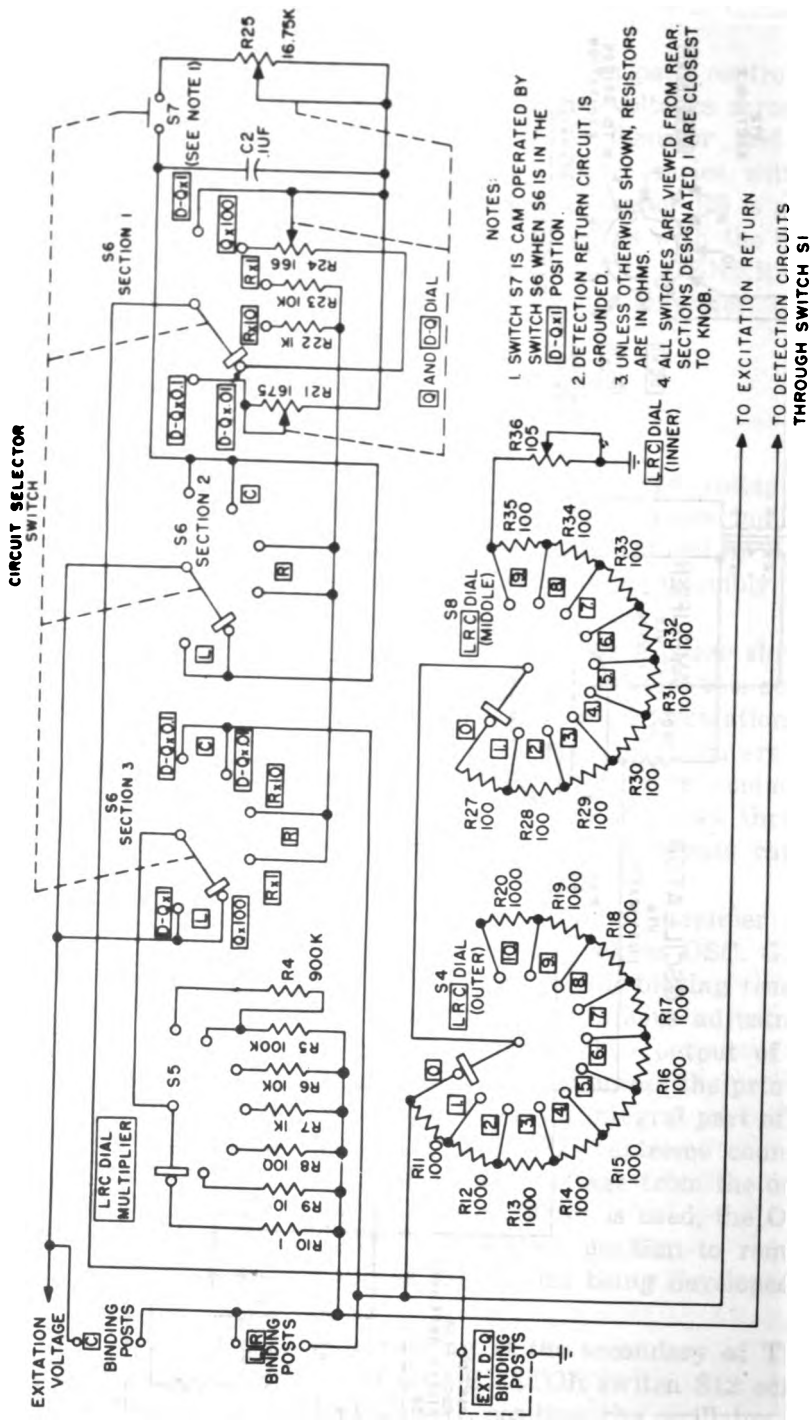

TM2646A-21

Figure 19. Bridge network circuit, simplified schematic diagram.

## 61. Bridge Network Circuit

a. *General.* The bridge network circuitry used for the various test set measurements is shown in figure 19. LRC DIAL MULTIPLIER S5 selects one of the ratio A arm (fig. 20) resistors R4 through R10 (fig. 19) to obtain a null balance. Resistors R21 through R25 in the ratio B arm (fig. 20) are selected by circuit selector switch S6, section 1. The Q and D-Q dial, consisting of rheostats R21, R24, and R25, controls these components in the ratio B arm. The circuit selector switch, with the connections to the binding posts, also alters the bridge network arrangement to the basic circuits shown in figures 20 through 23. Switch S7, actuated by a cam on the circuit selector switch, alters the bridge when measuring inductances when the circuit selector switch is in the L and D-Q x 1 position. Capacitor C2 is a precision component with a tolerance of  $\pm .25$  per cent and serves as the standard when measuring capacitors and inductors. The standard calibrated resistance against which components under measurement are compared is composed of resistors R11 through R20 (ratio arm N, fig. 21), selected by LRC outer dial switch S4; resistors R27 through R35, selected by LRC middle dial switch S8; and LRC inner dial potentiometer R36.

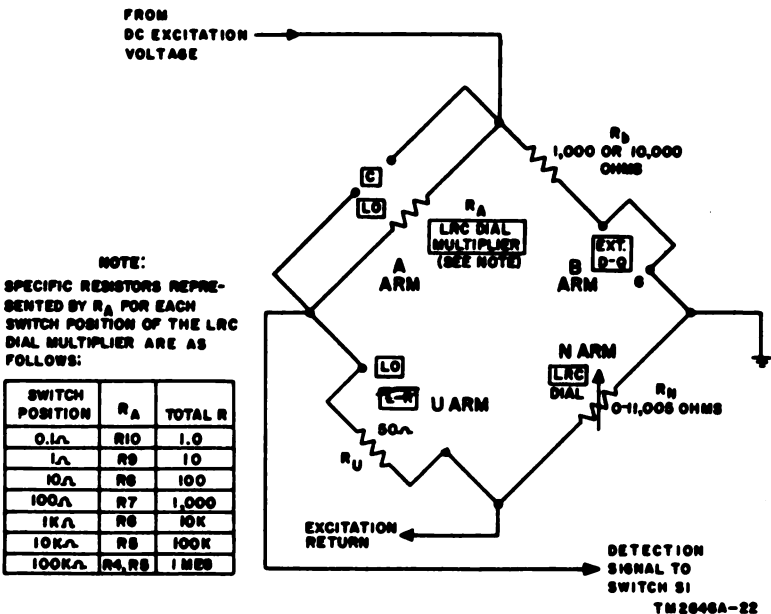

Figure 20. Wheatstone resistance bridge circuit, simplified schematic diagram.



b. *Wheatstone Resistance Bridge Circuit* (fig. 20). When measuring resistors, the bridge controls are adjusted as explained in paragraph 18. The network circuitry, when these adjustments are made, becomes a basic Wheatstone bridge composed of resistance arms  $R_u$ ,  $R_a$ ,  $R_n$ , and  $R_b$ .  $R_u$  represents the unknown resistor under measurement. When the voltage drop across resistance arm  $R_b$  equals the voltage drop across arm  $R_n$  and the voltage drop across resistance arm  $R_a$  equals the voltage drop across resistance arm  $R_u$ , no current flows in the detection circuit, and the bridge is considered to be balanced. The condition of balance may be expressed by the formula:

$$\frac{R_a}{R_b} = \frac{R_u}{R_n}$$

Evaluating for  $R_u$ , the formula becomes:

$$R_u = \frac{R_a R_n}{R_b}$$

When resistance arms  $R_x$  and  $R_z$  and resistor  $R_y$  are calibrated on the respective external dials by an operator to obtain a null indication, the value of unknown resistor  $R_u$  may be read directly from the LRC dial.

c. *Capacitance Bridge Circuit* (fig. 21). When measuring capacitors, the test set controls are manipulated as explained in paragraph 23. When the controls are adjusted, the network circuitry becomes a modified De Santy capacitance bridge of the unequal ratio arm type and uses standard capacitor C2 for measurement. The impedances for the two capacitance arms can be shown to be:

$$Z_u = R_u - jX_u \text{ and } Z_b = R_b - jX_{c_b}$$

where:  $Z_u$  is impedance of the U ratio arm (fig. 21).

$Z_b$  is impedance of the B ratio arm.

$X_u$  is reactance of the U ratio arm.

$X_{c_b}$  is reactance of the B ratio arm.

When a null exists in the detection circuits, the impedance arm ratios become:

$$\frac{Z_u}{Z_b} = \frac{R_a}{R_n} \text{ or } Z_u = \frac{R_a Z_b}{R_n}$$

Evaluating for the reactive parts of the represented impedances, the ratios are:

$$X_u = \frac{R_a X_b}{R_n} \text{ or } \frac{1}{\omega C_u} = \frac{R \left( \frac{1}{\omega C_b} \right)}{R_n}$$

Solving for  $C_u$ , the ratio becomes:

$$C_u = \frac{R_n C_b}{R_a}$$

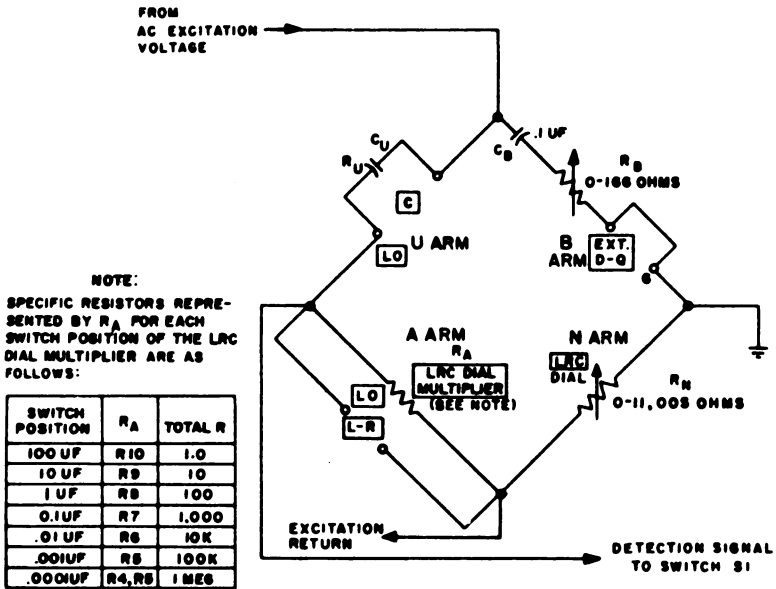

TM2646A-23

Figure 21. Modified De Santy capacitance bridge circuit, simplified schematic diagram.

As the bridge arms  $R_a$  and  $R_n$  are calibrated and because the capacitance  $C_b$  ( $C_2$ ) is a standard fixed value, the measurement of the unknown capacitor may be read directly.

d. *Maxwell Inductance Bridge Circuit* (fig. 22). For measurement of inductors having a storage factor ( $Q$ ) less than 10.5, the circuit selector switch is set at L and D-Q x 1 position and the rest of the controls are adjusted as explained in paragraph 26. The basic Maxwell bridge resulting compares the unknown inductance ( $L_u$ ) with standard capacitor  $C_2$  ( $C_b$ ). When a null exists in the detection circuits, the basic equation for the Maxwell bridge is:

$$L_u = R_a R_n C_b$$

and is comparatively independent of frequency. Further, as the bridge ratio arms A and N are set by the operator, and because capacitor  $C_2$  is a standard fixed value, the measurement of the unknown inductor is made by taking the readings and making the calculations indicated in paragraph 26j, example 1.

e. *Hay Inductance Bridge Circuit* (fig. 23). For measurement of inductors having a storage factor ( $Q$ ) between 9.5 and 1,000, the circuit selector switch is set in the L and Q x 100 position and the rest of the bridge controls are adjusted as explained in para-

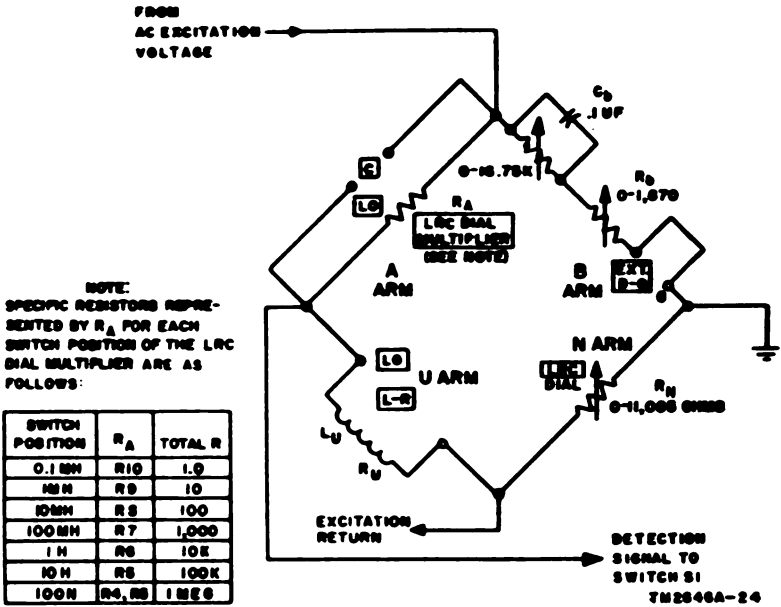

Figure 22. Maxwell inductance bridge circuit, simplified schematic diagram.

graph 26. The resulting Hay inductance bridge compares unknown inductance  $L_u$  with standard capacitor  $C_2$  ( $C_s$ ). Unlike the Maxwell bridge (*d* above), the Hay bridge depends on frequency, particularly when the inductance has a relatively low  $Q$  (a  $Q$  of 10 or less). For this reason the Hay bridge is not used to measure inductance having a  $Q$  below 10. As the  $Q$  of the inductance increases, the considered losses due to frequency become more negligible. For storage factors of approximately 10, or greater, as measured with the Hay bridge circuit, the equation for the Hay bridge circuit is:

$$L_u = R_a R_b C_b$$

Since the bridge arms  $R_a$  and  $R_b$  are set by the operator, and because standard capacitor  $C_2$  has a fixed value, the readings for unknown inductor  $L_u$  may be taken and the calculations made (par. 26j, example 1).

## 62. Detection Signal Amplifier Circuit (fig. 24)

a. The ac detection signal from the bridge circuit is capacitively coupled to the amplifier circuit when DETECTOR switch S1 is in the INTERNAL position by coupling capacitor C28. AMP.

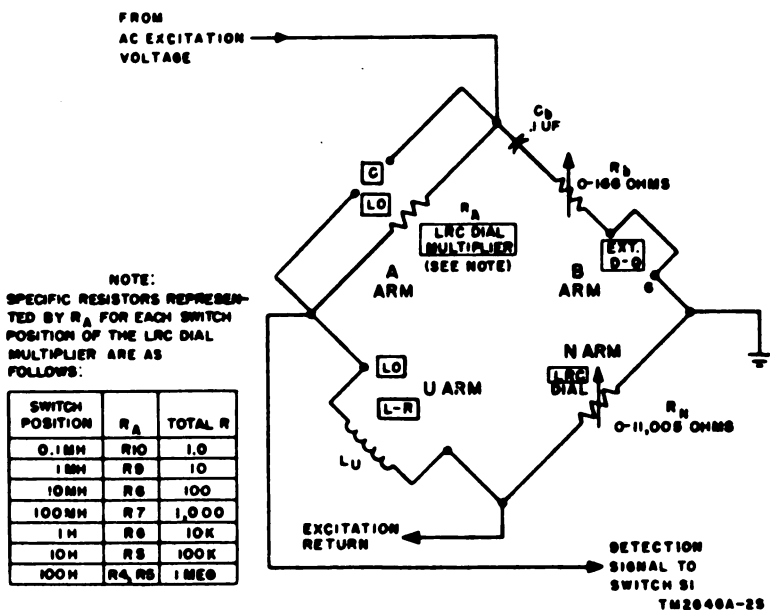

Figure 23. Hay inductance bridge circuit, simplified schematic diagram.

GAIN control R65 serves as both the signal level adjustment and the grid return for first stage amplifier V3A.

b. Amplifier V3A uses cathode bias through cathode-biasing resistor R39 and bypass capacitor C25, section A. Resistor R38 is the plate load for the first stage, and capacitor C23 couples the output signal to the grid of second stage amplifier V3B. Cathode-biasing resistor R40 and bypass capacitor C26, section B provide bias for second stage amplifier V3B. Resistor R41 is the grid return and resistor R42 as the plate load for second stage amplifier V3B.

c. Filtering of the output of second stage amplifier V3B is provided by part of oscillator-filter assembly Z3. When the AMP. RESPONSE switch is in the PEAK position, the filter is coupled between the output plate load and grid circuits of second stage amplifier V3B. This filter provides a high gain at the oscillator excitation frequency of 1,000 cycles, and a high relative attenuation to signals above and below that frequency. The response curve for the filter at various frequencies is shown in figure 25.

d. Resistor R52 and capacitor C25 form a decoupling network. The amplified detection signal passes from the plate of second stage amplifier V3B directly to the null detector located in the detection circuits.

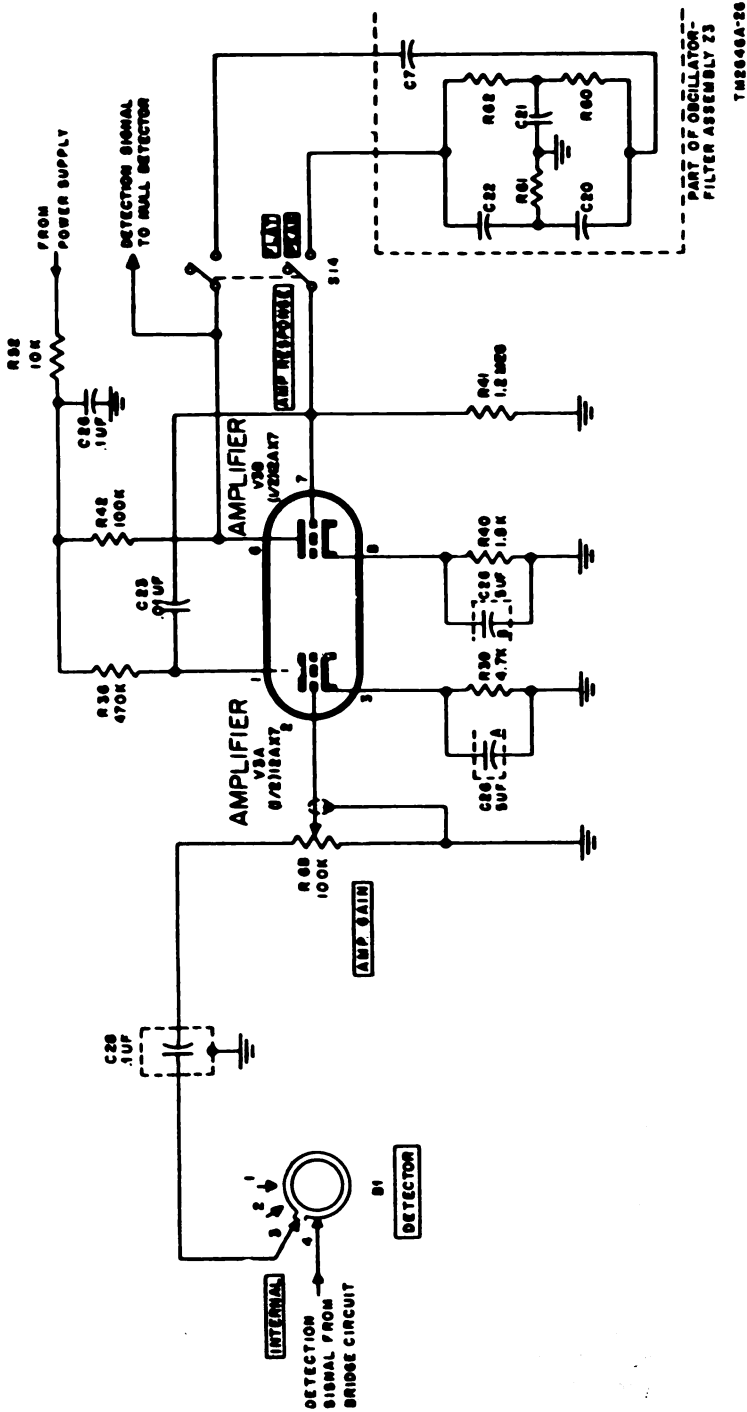

Figure 24. Amplifier circuit, simplified schematic diagram.

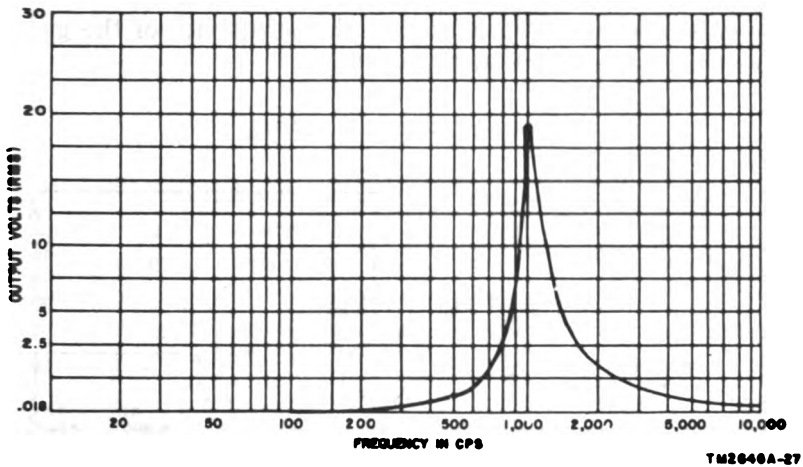

Figure 25. Amplifier circuit filter response curve.

### 63. Detection Circuits

a. The detection signals to the detection circuits are controlled by DETECTOR switch S1 (fig. 37) and are directly coupled to the detector except for the INTERNAL position (par. 61), which controls the input to the amplifier circuit. When the DETECTOR switch is in the INTERNAL position, the detector signal from the amplifier circuit is coupled, through capacitor C9 to the grid (pin 3) of null detector V2 (B, fig. 26). The plate (pin 4) of tube V2 is connected directly to the B+ power supply and the deflector plate (pin 2) is connected to B+ through plate voltage-dropping resistor R43. Resistor R44 is the grid-leak resistor. The PHONES jacks are connected across the grid of null detector V2 to ground, and are provided for audio null detection purposes.

b. When DETECTOR switch S1 is in the EXTERNAL position, the detection signal from the bridge circuit is channeled directly to the EXT. DET. binding posts on the front panel (A, fig. 26) through contacts 4 and 2 of S1. Provision is thus available for connecting other detection devices, such as oscilloscopes, output voltmeters, etc. However when S1 is in the EXTERNAL position, the detection signal amplifier (par. 61) is switched out of the circuit (fig. 37).

c. When in the METER position, the DETECTOR switch connects the detection signal directly to galvanometer M1 (A, fig. 26). The galvanometer is a conventional D'Arsonval type meter, with 7.5 microamperes sensitivity in either direction from center 0

position. Resistor R1 is the damping resistor and resistor R2 is the shunt for the galvanometer. When operated, push-to-operate METER SHUNT switch S13 connects the detector signal directly to the galvanometer. This increases the sensitivity of the galvanometer for fine adjustments.

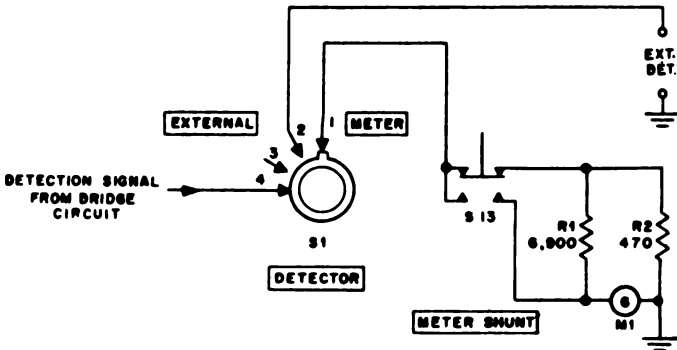

A. DC DETECTOR

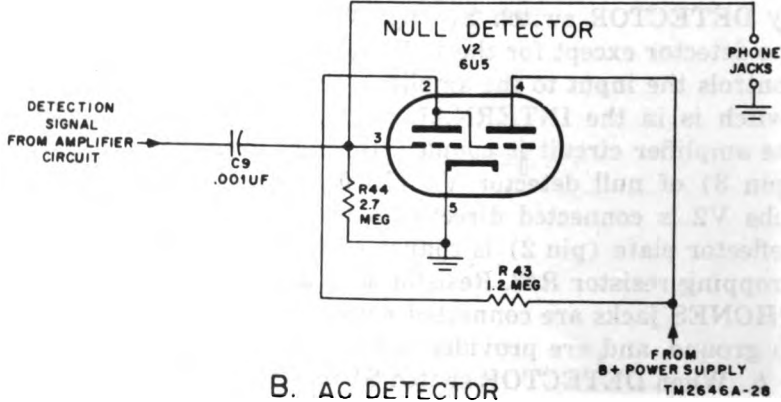

B. AC DETECTOR

Figure 26. Detection circuits, simplified schematic diagram.

## CHAPTER 6

### FIELD MAINTENANCE

*Note.* This chapter contains information for field maintenance repairmen having the minimum training of an electronic instrument repairman. The amount of repair that can be performed by units having field maintenance responsibility is limited only by the tools and test equipment available and by the skill of the repairman.

---

#### Section I. TROUBLE SHOOTING AT FIELD MAINTENANCE LEVEL

**Warning:** Certain points located throughout the chassis of the test set operate at voltages above 310 volts (fig. 28 and 29). Do not touch these points while power is applied to the test set.

#### 64. Trouble-shooting Procedures

*a. General.* The first step in servicing a defective bridge is to sectionalize the fault. Sectionalization means tracing the fault to the circuit responsible for the abnormal operation of the test set. The second step is to localize the fault. Localization means tracing the fault to the defective part responsible for the abnormal condition. Some faults, such as burned-out resistors, arcing, shorted transformers, leaky capacitors, or broken wires, often can be located by sight, smell, and hearing (par. 53). The majority of faults, however, must be localized by checking voltages and resistances (fig. 28 and 29).

*b. Component Sectionalization and Localization.* Listed below are a group of tests arranged to simplify and reduce unnecessary work and to aid in tracing a trouble to a specific part. Follow the procedures carefully in the sequence given.

- (1) *Visual inspection.* Visual inspection (par. 53) is to locate any visible trouble. Through this inspection alone, the repairman frequently may discover the trouble or determine the circuit in which the trouble exists. This inspection is valuable in avoiding additional damage, which



might occur through improper servicing methods, and in forestalling future failures.

- (2) *Checking for shorts.* The B+ and filament supply circuits should be checked (par. 68) for possible shorts before the equipment is tested with the power applied. These measurements prevent further damage to the equipment from possible short circuits.
- (3) *Operational test.* Operational tests frequently indicate the general location of trouble. In many instances, the information gained will determine the exact nature of the fault. All symptoms must be interpreted in relation to one another. To perform an operational test on the bridge use the equipment performance check list (par. 56).
- (4) *Trouble-shooting chart.* The trouble symptoms listed in this chart (par. 69) will aid greatly in localizing trouble.
- (5) *Intermittent troubles.* In all these tests, the possibility of intermittent conditions should not be overlooked. If present, this type of trouble often may appear by tapping or jarring the equipment. It is possible that some external conditions may cause the trouble. Check wiring for loose connections and carefully apply a small amount of pressure to wires and components with an insulated tool. This will show where a faulty connection or component is located.

## 65. Trouble-shooting Data

The material supplied in this manual will aid in the rapid location of faults. Consult the following trouble-shooting data:

Fig. or par. No.	Title
Fig. 17	Power supply, simplified schematic diagram.
Fig. 18	Oscillator-amplifier circuit, simplified schematic diagram.
Fig. 19	Bridge network circuit, simplified schematic diagram.
Fig. 24	Amplifier circuit, simplified schematic diagram.
Fig. 26	Detection circuits, simplified schematic diagram.
Fig. 27	Test set, voltage distribution.
Fig. 28	Test set, tube socket voltage and resistance diagram.
Fig. 29	Test set, terminal board voltage and resistance diagram.
Fig. 30	Capacitance-Inductance-Resistance Test Set AN/URM-90, top view of chassis, location of parts.
Fig. 31	Capacitance-Inductance-Resistance Test Set AN/URM-90, bottom view of chassis, location of parts.
Fig. 32	Capacitance-Inductance-Resistance Test Set AN/URM-90, right side view of chassis, location of parts.

Fig. or par. No.	Title
Fig. 33	Terminal board assembly E2, bottom view, showing location of resistors.
Fig. 35	MIL STD capacitor color codes.
Fig. 36	MIL STD resistor color codes.
Fig. 37	Test set, schematic diagram.
Fig. 38	Test set, wiring diagram.
Par. 53	Trouble shooting by visual inspection.
Par. 54	Trouble shooting and replacing faulty tubes.
Par. 56	Equipment performance check list.
Par. 64	Trouble-shooting procedures.
Par. 68	Checking filament and B+ circuits for shorts.
Par. 69	Trouble-shooting chart.
Par. 70	Dc resistances of transformers.

## 66. Test Equipment Required for Trouble Shooting

The test equipment required for trouble shooting the test set is listed in the table below. Technical manuals associated with each item also are listed.

Test equipment	Technical manual
Electron Tube Test Set TV-2/U	TM 11-2661
Multimeter TS-352/U	TM 11-5527
Resistance Bridge ZM-4A/U	TM 11-2019
Frequency Meter FR-67/U	TM 11-2698

## 67. General Precautions

Observe the following precautions carefully when servicing the test set:

a. Be careful when servicing the bridge when removed from its case; dangerous voltages are exposed.

b. If the test set has been operating for some time, prevent burns on the hand or fingers by using a cloth when removing the hot metal tube shields and a tube puller to remove the tubes.

c. When moving the test set during servicing operations, check to be sure the galvanometer needle is secured by moving the galvanometer needle clamp to the CLAMP position.

d. Do not overtighten screws when assembling mechanical couplings.

e. When changing a component that is secured with screws, be sure to replace the lock washers.

f. Careless replacement of parts often makes new faults inevitable. Note the following points:

- (1) Before a part is unsoldered, note the position of the leads. If the part, such as a wafer switch or transformer, has a number of connections, tag each lead before removing it.

- (2) Be careful not to damage other leads by pushing or pulling them out of the way.
- (3) Be careful when using a soldering iron near decade resistors R4 through R20 and R27 through R35 (fig. 32). These decade resistors are precision parts and exposure to excessive heat may materially change their resistance, thus affecting the over-all accuracy of the bridge.
- (4) Do not attempt to replace the individual decade resistors. Replace the entire decade unit when tests indicate faulty individual decade resistor.
- (5) Do not allow drops of solder to fall into parts of the chassis. They may cause short circuits.
- (6) A carelessly soldered connection may create new faults. It is important to make well-soldered joints because a poorly soldered joint is one of the most difficult faults to find.
- (7) The bridge contains a number of precision electrical components, which must be replaced by identical replacement parts. Give particular attention to proper grounding when replacing a part; use the same ground as in the original wiring. Failure to observe these precautions may result in improper bridge operation or instability.

## 68. Checking Filament and B+ Circuits for Shorts

*a. General.* Short circuits in either the B+ or filament circuits of the bridge may disable the unit. If the bridge is operated with a short circuit, the increased current that results may permanently damage the tubes and other circuit components. Figure 27 shows schematically the components of the B+ circuit.

*b. Short Circuit Indications.* Short circuits may be suspected because of any one of the following symptoms:

- (1) Abnormally short tube life.
- (2) Evidences of discoloration caused by overheating.
- (3) Burned-out fuse F1.
- (4) Melted or charred insulation on bridge wiring.
- (5) Improper bridge operation, particularly when making capacitance and inductance measurements.

*c. Short Circuit Checks.* To check for short circuits without causing additional damage to the bridge, proceed as follows:

- (1) Disconnect all power to the bridge.
- (2) Remove the bridge chassis from the case (par. 51b(2)).

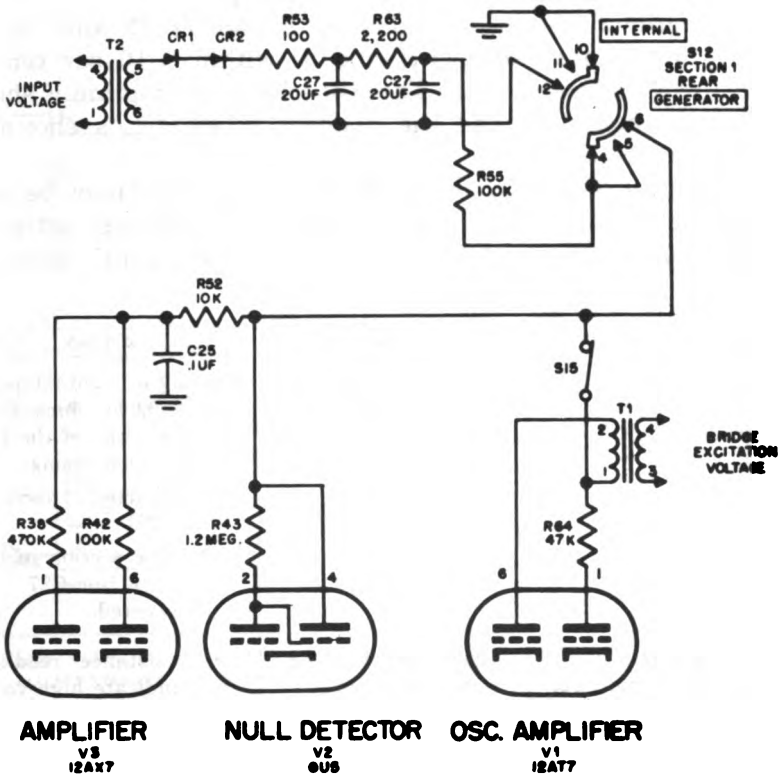

TM2646A-29

Figure 27. Test set, B+ voltage distribution.

**NULL DETECTOR**  
XV2  
6U8

**AMPLIFIER**  
XV3  
12AX7

**OSCILLATOR-AMPLIFIER**  
XV1  
12AT7

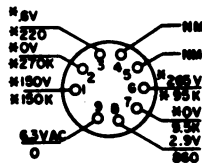
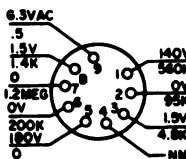
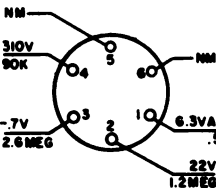

- NOTES:
1. LINE VOLTAGE 115 VOLTS.
  2. ALL RESISTANCES ARE IN OHMS, EXCEPT WHERE OTHERWISE SPECIFIED.
  3. NM MEANS NOT TO BE MEASURED.
  4. MAKE ALL MEASUREMENTS WITH 20,000 OHM-PER-VOLT METER.

5. [GENERATOR] SWITCH IN [INTERNAL] POSITION.
6. ALL MEASUREMENTS ARE MADE FROM TUBE SOCKET PIN TO CHASSIS GROUND. VOLTAGE READINGS ARE SHOWN ABOVE THE LINE AND RESISTANCE READINGS BELOW THE LINE.

7. [OSC. GAIN] SWITCH IN [OFF] POSITION EXCEPT FOR MEASUREMENTS WITH ASTERISK (\*). THESE MEASUREMENTS MADE WITH [OSC. GAIN] SWITCH IN HI POSITION.

TM2646A-34

Figure 28. Test set, tube socket voltage and resistance diagram.

(3) Use Multimeter TS-352/U and perform resistance to ground checks as indicated in figures 29 and 30. All resistance readings should be within  $\pm 10$  per cent of the indicated value. The B+ schematic diagram is shown in figure 27 and the filament schematic is shown in figure 37.

*d. Isolating Short Circuits.* The following chart may be used in conjunction with the check readings performed as instructed in *c*(3) above to isolate the probable causes of abnormal resistance readings :

Points of measurements	Normal indication ( $\pm 10\%$ )	Isolation
Between pin 6 of tube socket X7 (V3) and ground.	Resistance reading of 200,000 ohms.	Reading of approximately 100,000 ohms may indicate one of the following conditions: (1) Shorted capacitor C25. (2) One section of capacitor C27 shorted.
Between pins 5 and 6 of transformer T2.	Resistance reading of 414 ohms.	Low resistance reading will indicate high-voltage winding of transformer T2 shorted.
Between pin 9 of tube socket X6 (VI and ground.	Resistance reading of .5 ohm.	Zero resistance reading may indicate one of the following conditions: (1) Shorted filament winding of transformer T2. (1) Short across filament of V1, V2, or V3.

\*All readings shall be made with the GENERATOR switch in the INTERNAL position.

## 69. Trouble-shooting Chart

The following chart is supplied as an aid in locating trouble in the test set. It lists the symptoms the repairman observes, either visual or audible, while making tests. The chart also indicates how to localize trouble quickly to a particular stage or circuit. After the trouble has been localized to a stage or circuit, a tube check and voltage and resistance measurements of the circuit (fig. 28 and 29), ordinarily should be sufficient to isolate the defective part.

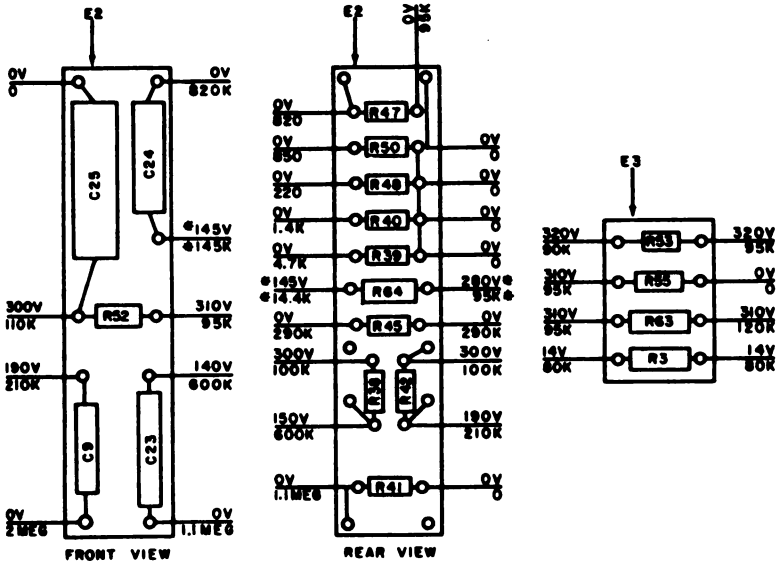

NOTES:

1. LINE VOLTAGE IS 115 VOLTS.
2. ALL RESISTANCES ARE IN OHMS.
3. VOLTAGES MEASURED WITH 20,000 OHMS-PER-VOLT METER.
4. GENERATOR SWITCH IN INTERNAL POSITION.

5. OSC. GAIN CONTROL IN OFF POSITION EXCEPT WHERE INDICATED WITH ASTERISK (\*), THESE MEASUREMENTS ARE MADE WITH SWITCH IN ON POSITION.
6. VOLTAGE READINGS ABOVE LINE, AND RESISTANCE TO GROUND BELOW LINE.

TM2646A-35

Figure 29. Test set, terminal board voltage and resistance diagram.

Symptom	Probable cause	Correction
1. Pilot lamp I 1 does not light when POWER switch is moved to ON.	<ol style="list-style-type: none"> <li>a. Burned-out fuse F1.</li> <li>b. Defective POWER switch S16.</li> <li>c. Burned-out pilot lamp I 1.</li> </ol>	<ol style="list-style-type: none"> <li>a. Replace defective fuse (par. 58).</li> <li>b. Replace defective switch (par. 81).</li> <li>c. Replace pilot lamp (par. 57).</li> </ol>
2. Electron ray tube V2 does not light when GENERATOR switch S12 is turned to EXTERNAL or INTERNAL position.	<ol style="list-style-type: none"> <li>a. Defective transformer T1.</li> <li>b. Defective or dirty GENERATOR switch S12.</li> <li>c. Defective electron ray tube V2.</li> </ol>	<ol style="list-style-type: none"> <li>a. Replace transformer (par. 86).</li> <li>b. Clean or replace switch (par. 83).</li> <li>c. Replace electron ray tube (par. 54).</li> </ol>
3. Rotation of OSC. GAIN control does not affect shadow width on electron ray tube V2.	<ol style="list-style-type: none"> <li>a. Defective OSC. GAIN control (R66 and S15).</li> </ol>	<ol style="list-style-type: none"> <li>a. Replace control (par. 75).</li> </ol>

Symptom	Probable cause	Correction
4. Erratic or inoperative galvanometer operation.	<ul style="list-style-type: none"> <li>a. Defective galvanometer M1.</li> <li>b. Defective transformer T2.</li> <li>c. Defective or dirty DETECTOR switch S1.</li> <li>d. Defective METER SHUNT switch S13.</li> <li>e. Defective resistor R1 or R2.</li> </ul>	<ul style="list-style-type: none"> <li>a. Replace galvanometer (par. 74).</li> <li>b. Replace transformer T2 (par. 86).</li> <li>c. Clean or replace switch S1 (par. 84).</li> <li>d. Replace switch S13 (par. 78).</li> <li>e. Replace defective resistor R1 or R2 (par. 78).</li> </ul>
5. No audible tone signal in headset when detecting aurally.	<ul style="list-style-type: none"> <li>a. Defective oscillator-filter Z3.</li> <li>b. Defective electron ray tube V1.</li> <li>c. Defective PHONES jack J2 or J3.</li> <li>d. Defective or dirty DETECTOR switch S1.</li> </ul>	<ul style="list-style-type: none"> <li>a. Replace oscillator-filter Z3 (par. 77).</li> <li>b. Replace tube V1 (par. 54).</li> <li>c. Replace defective jack J2 or J3 (par. 88).</li> <li>d. Clean or replace switch S1 (par. 84).</li> </ul>
6. Bridge operates satisfactorily, except when using external generator.	<ul style="list-style-type: none"> <li>a. Defective or dirty GENERATOR switch S12.</li> </ul>	<ul style="list-style-type: none"> <li>a. Clean or replace switch S12 (par. 83).</li> </ul>
7. Bridge operation erratic and inaccurate on all ranges when LRC dial is adjusted.	<ul style="list-style-type: none"> <li>a. Defective or dirty variable resistor R36.</li> <li>b. EXT. D-Q binding posts not shorted.</li> <li>c. Dirty or defective switch S4 or S8.</li> </ul>	<ul style="list-style-type: none"> <li>a. Clean or replace variable resistor R36.</li> <li>b. Insert shorting bar between binding posts.</li> <li>c. Clean or replace switches.</li> </ul>
8. Bridge operation erratic or inaccurate only on certain ranges of the LRC DIAL MULTIPLIER and circuit selector switch.	<ul style="list-style-type: none"> <li>a. Defective decade resistors R11 through R20, or R27 through R35 (one or more).</li> <li>b. Dirty or defective switch S4 or S8.</li> <li>c. Defective resistor R22 or R23.</li> </ul>	<ul style="list-style-type: none"> <li>a. Replace defective switch assembly.</li> <li>b. Clean if found dirty. Replace defective switch.</li> <li>c. Replace defective resistor.</li> </ul>
9. Operation of METER SHUNT switch does not increase galvanometer sensitivity.	<ul style="list-style-type: none"> <li>a. Defective METER SHUNT switch S13.</li> <li>b. Defective resistor R1 or R2.</li> </ul>	<ul style="list-style-type: none"> <li>a. Replace switch S13 (par. 78).</li> <li>b. Replace defective resistor.</li> </ul>

Symptom	Probable cause	Correction
10. Bridge inoperative for dc resistance measurements.	<p><i>a.</i> Burned-out fuse F1.</p> <p><i>b.</i> Defective POWER switch S16.</p> <p><i>c.</i> Defective transformer T2.</p> <p><i>d.</i> Defective GENERATOR switch S12.</p> <p><i>e.</i> Faulty wiring if galvanometer will not center at 0.</p> <p><i>f.</i> EXT. D-Q binding posts not shorted.</p> <p><i>g.</i> Defective or dirty switch S5 or S6.</p> <p><i>h.</i> Open or defective variable resistor R36.</p> <p><i>i.</i> Defective DETECTOR switch S1.</p> <p><i>j.</i> Defective galvanometer M1.</p>	<p><i>a.</i> Replace defective fuse (par. 58).</p> <p><i>b.</i> Replace switch S16 (par. 81).</p> <p><i>c.</i> Replace transformer (par. 86).</p> <p><i>d.</i> Replace switch S12 (par. 83).</p> <p><i>e.</i> Check wiring for short circuits. Check exposed wiring for shorts to metal cabinet (par. 68).</p> <p><i>f.</i> Insert shorting bar between EXT. D-Q binding posts.</p> <p><i>g.</i> Clean contacts or replace affected switch.</p> <p><i>h.</i> Adjust or replace variable resistor R36.</p> <p><i>i.</i> Replace or repair switch S1 (par. 84).</p> <p><i>j.</i> Replace galvanometer M1 (par. 74).</p>
11. Bridge inoperative for capacitance or inductance measurements (ac measurements).	<p><i>a.</i> Defective tube V1, V2, V3.</p> <p><i>b.</i> Open in AMP. GAIN control R65. (Control grid of tube V1 to ground should measure 100K when AMP. GAIN control is in H1 position.)</p> <p><i>c.</i> Shorted section (A, B, or C) capacitor C26.</p> <p><i>d.</i> Faulty oscillator-filter assembly Z3.</p> <p><i>e.</i> Defective transformer T1.</p> <p><i>f.</i> Shorted or defective capacitor C2.</p> <p><i>g.</i> Burned-out fuse F1.</p>	<p><i>a.</i> Check tubes, replace defective tube or tubes (par. 54).</p> <p><i>b.</i> Replace AMP. GAIN control R65 (par. 82).</p> <p><i>c.</i> Replace capacitor C26 (par. 73).</p> <p><i>d.</i> Replace oscillator-filter assembly Z3 (par. 77).</p> <p><i>e.</i> Replace transformer T1 (par. 86).</p> <p><i>f.</i> Replace capacitor C2 (par. 72).</p> <p><i>g.</i> Replace defective fuse F1 (par. 58).</p>



Symptom	Probable cause	Correction
	<i>h.</i> Defective POWER switch S16. <i>i.</i> Defective transformer T2. <i>j.</i> Defective GENERATOR switch S12. <i>k.</i> EXT. D-Q binding posts not shorted.  <i>l.</i> Defective or dirty switch S5 or S6. <i>m.</i> Open or defective variable resistor R21.  <i>n.</i> Open or defective variable resistor R36.  <i>o.</i> Defective DETECTOR switch S1.	<i>h.</i> Replace switch S16 (par. 81). <i>i.</i> Replace transformer T2 (par. 86). <i>j.</i> Replace or repair switch (par. 83). <i>k.</i> Insert shorting bar between binding posts.  <i>l.</i> Clean or replace affected switch. <i>m.</i> Replace or repair resistor R21.  <i>n.</i> Replace faulty variable resistor R36.  <i>o.</i> Replace or repair switch S1 (par. 84).

## 70. Dc Resistances of Transformers

The dc resistances of transformers T1 and T2 in the test set are listed below :

Transformer	Terminals	Ohms
T1	1-2	2,512
	3-4	222
T2	1-4	19.5
	5-6	413.5
	7-8	.257
	9-10	3.5

## Section II. REPAIRS

### 71. Replacement of Parts

*Note.* Sometimes dissimilar components on the bridge are provided with common mountings. For example, the resistor and switch assembly consists of switch S5, part of switch S6, and decade resistors R4 through R10.

*a.* Before replacing any component part of the bridge not explained in paragraphs 72 through 91, refer to paragraph 67.

b. Before replacing or repairing any parts, such as capacitors, variable resistors, terminal boards, or switches, refer to paragraph 67f(1). The bridge contains a number of bus wire type interconnections; therefore, before removing any bus wire connection, carefully note the exact routing and all connecting techniques used. Improper replacement of these wires may affect the design characteristics of the bridge. Use the wiring diagram (fig. 38) as a guide in connecting wires between terminals; use the old lead, if possible, as a guide in forming the new lead.

c. Carefully note the dial and pointer settings of each switch and variable resistor relative to the actual physical position of the component wiper or contact prior to disassembly. Use these notes to insure correct reassembly.

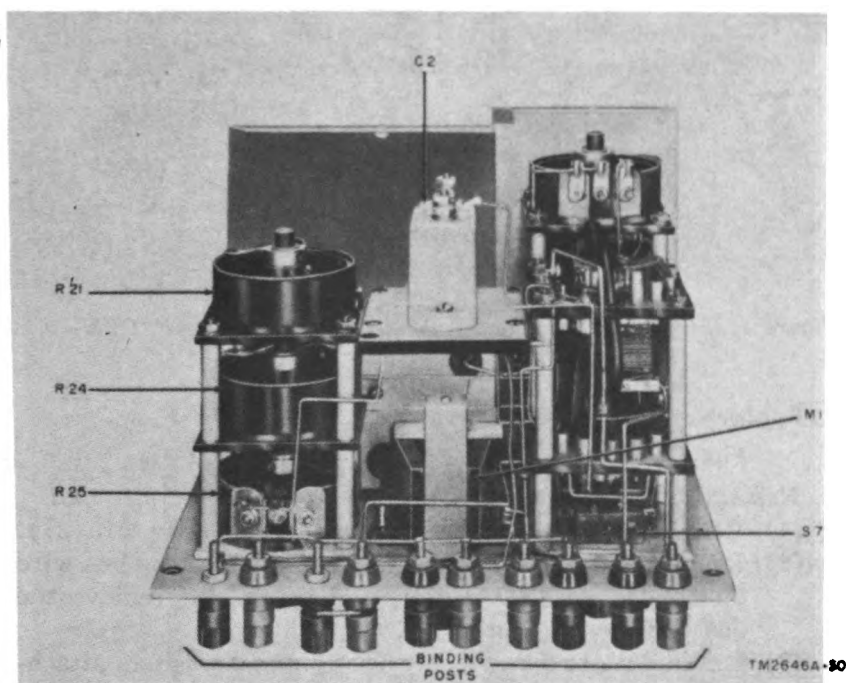
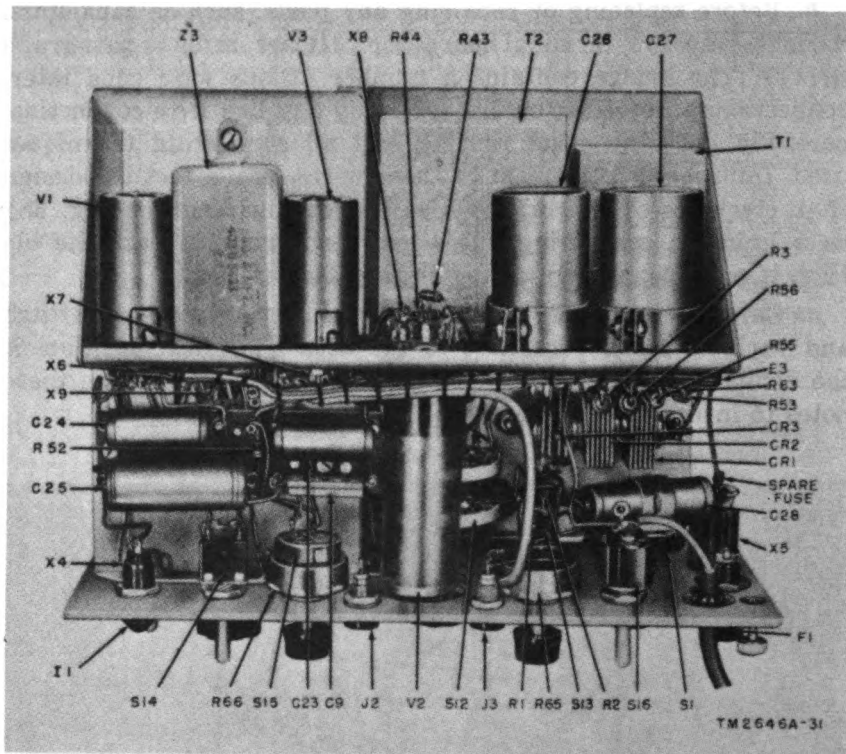

Figure 30. Capacitance-Inductance-Resistance Test Set AN/URM-90, top view of chassis, location of parts.

d. To remove the bridge chassis from the case, refer to paragraph 51b(2). For servicing, the chassis should be placed on a work bench so that the part of chassis to be serviced is closest to the repair personnel.

**Warning:** Discharge capacitor C2 (fig. 30) by shorting the capacitor terminals before making any repairs to the set.



**Figure 31.** *Capacitance-Inductance-Resistance Test Set AN/URM-90, bottom view of chassis, location of parts.*

## **72. Replacing Capacitor C2** (fig. 30)

### **a. Removing Capacitor C2.**

- (1) Remove the bridge chassis from the case (par. 51b(2)).
- (2) Remove the two hexagonal nuts that attach the bus wire terminals to the capacitor studs. Tag and remove the bus wire connections (par. 67f).
- (3) Remove the two binder head screws and washers attaching the capacitor to the mounting board.

### **b. Reassembling Capacitor C2.**

- (1) Mount the capacitor on the mounting board with the binder head screws and washers.
- (2) Replace the bus wire terminals on the proper capacitor studs.
- (3) Secure the bus wire terminals by replacing the two hexagonal nuts on the capacitor studs.
- (4) Replace the bridge chassis in the carrying case (par. 51b(11)).

### 73. Replacing Capacitors C26 and C27

(fig. 31)

#### a. Removing Capacitors C26 and C27.

- (1) Remove the bridge chassis from the carrying case (par. 51b(2)).
- (2) Unsolder the leads from the bottom of the faulty capacitor. Refer to paragraph 67f before unsoldering any of the leads.
- (3) Note the index marks on the bottom of the faulty capacitor, and mark the location of these index marks on the mounting plate so that the new capacitor can be positioned exactly as the faulty capacitor.
- (4) Loosen the retaining screw on the capacitor mounting bracket. Carefully slide the faulty capacitor out of the mounting bracket.

#### b. Reassembling Capacitors C26 and C27.

- (1) Check the index markings on the bottom of the new capacitor.

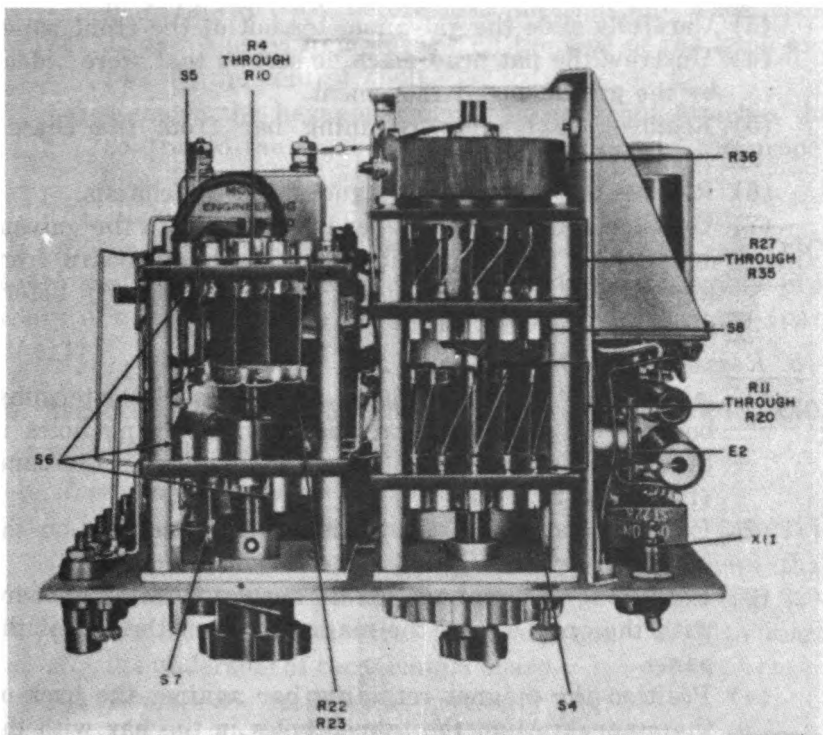

TM 55-000-32

Figure 32. Capacitance-Inductance-Resistance Test Set AN/URM-90, right side view of chassis, location of parts

- (2) Slide the new capacitor into the capacitor mounting bracket. Turn the new capacitor so that it is positioned exactly as the faulty capacitor was positioned.
- (3) Tighten the retaining screw on the capacitor mounting bracket.
- (4) Connect the leads to the terminals on the bottom of the new capacitor (fig. 38). Do not bend or twist the terminals on the capacitor.
- (5) Solder the connections on the bottom of the new capacitor.
- (6) Replace the bridge chassis in the carrying case (par. 51b(11)).

## **74. Replacing Galvanometer M1**

### *a. Removing Galvanometer M1.*

- (1) Remove the bridge chassis from the carrying case (par. 51b(2)).
- (2) Unscrew the two fillister head screws that secure the galvanometer into the front panel (fig. 4).
- (3) Carefully slide the galvanometer out of the front panel.
- (4) Unscrew the flat head machine screws that were hidden by the galvanometer movement.
- (5) Remove the magnet retaining bar from the chassis (fig. 30).
- (6) Remove the permanent magnet from the chassis.
- (7) Unsolder and remove the leads connected to the galvanometer and remove the insulating terminal board from the rear of the panel. Refer to paragraph 67f before disconnecting any leads.

### *b. Reassembling Galvanometer M1.*

- (1) Align the two tapped holes in the insulator-terminal board with the upper galvanometer mounting holes in the panel and slide the studs into the holes in the panel (fig. 4 and 30).
- (2) Connect and solder the leads to the terminals on the insulator-terminal board.
- (3) Position the magnet against the insulator-terminal board with the open end of the magnet toward the top of the panel.
- (4) Position the magnet retaining bar against the back of the magnet. Align the tapped holes in the bar with the lower mounting holes in the front panel.
- (5) Replace the flat head screws. Do not tighten beyond the point necessary to retain the mounted parts.

- (6) Temporarily insert the meter movement in the hole in the panel to check meter clearance.
- (7) Remove the meter movement and loosen the flat headed screws. Align the open end of the magnet so that the meter movement is positioned exactly in the center of the opening and the end of the magnet is flush with the top of the meter movement.
- (8) Replace the meter movement in the front panel.
- (9) Replace and tighten the fillister head screws that retain the meter movement.
- (10) Replace the bridge chassis in the carrying case (par. 51b(11)).

## **75. Replacing OSC. GAIN Control (R66 and S15)** (fig. 31)

### *a. Removing OSC. GAIN Control.*

- (1) Remove the bridge chassis from the case (par. 51b(2)).
- (2) Unsolder the leads from the back of the switch. Refer to paragraph 67f before disconnecting any leads.
- (3) Loosen the retaining screw on the side of the knob and remove the control knob.
- (4) Remove the hexagonal mounting nut that attaches the control to the front panel with a wrench of the proper size. Be careful not to scratch the front panel.
- (5) Slide the control from the rear of the front panel

*b. Reassembling OSC. GAIN Control.* Install the new OSC. GAIN control on the bridge by reversing the disassembly procedure in *a* above. Replace the chassis in the carrying case (par. 51b(11)).

## **76. Replacing Resistors R38 Through R42, R45, R47, R48, R50, and R64 on Terminal Board E2**

### *a. Removing Resistors.*

- (1) Remove the bridge chassis from the case (par. 51b(2)).
- (2) Remove the two retaining screws and washers that attach terminal board E2 to the bridge chassis (fig. 32).
- (3) Unsolder all lead wires necessary (par. 67f) to reach the underside of the terminal board.
- (4) Replace the resistors as necessary (fig. 33).

*Note.* To replace terminal board E2, unsolder all resistors (from the bottom) and capacitors (from the top, fig. 32) and resolder these components on the replacement board.

*b. Reassembling Terminal Board.*

- (1) Resolder all resistor lead wires to the terminal board (fig. 33).
- (2) Position the terminal board on the standoff mounting spacers.
- (3) Replace the two screws and washers that attach the terminal board.
- (4) Replace the bridge chassis in the carrying case (par. 51b(11)).

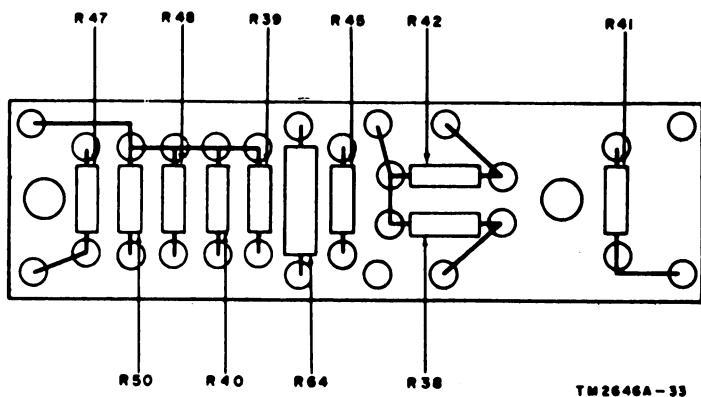

Figure 33. Terminal board assembly E2, bottom view, showing location of resistors.

## 77. Replacing Oscillator-filter Control Assembly Z3

(fig. 16 and 31)

*Note.* Do not attempt any repair operations or replacement of resistors or capacitors within sealed oscillator-filter assembly Z3 (fig. 31). If in doubt as to the condition of the internal components, replace the entire assembly.

*a. Removing Oscillator-filter Assembly Z3.*

- (1) Remove the bridge chassis from the carrying case (par. 51b(2)).
- (2) Unscrew the retaining screw from the bracket on the top of the filter control assembly (fig. 16).
- (3) Pull the filter control assembly out of the socket. Be careful not to twist the assembly so the socket is damaged.

**b. Installing Oscillator-filter Assembly Z3.**

- (1) Slide the new filter assembly into the socket. Be sure it is positioned correctly.
- (2) Replace the retaining screw in the bracket on the top of the filter assembly.
- (3) Replace the bridge chassis in the carrying case (par. 51b(11)).

**78. Replacing METER SHUNT Switch S13**

(fig. 31)

**a. Removing METER SHUNT Switch S13.**

- (1) Remove the bridge chassis from the carrying case (par. 51b(2)).
- (2) Unscrew the retaining nut on the front panel and slide the METER SHUNT switch out of the front panel.
- (3) Unsolder the leads connected to the switch. Refer to paragraph 67f before disconnecting any leads.
- (4) Unsolder the resistors (R1 and R2) connected to the switch. Save the resistors so they can be used on the new switch.

**b. Installing METER SHUNT Switch S13.**

- (1) Connect the resistors to the new switch. Be sure the resistors are connected to the correct terminals. (fig. 38).
- (2) Connect the leads to the switch and solder the connection. Be sure the leads are connected to the correct terminals.
- (3) Slide the switch into the front panel, and replace the retaining nut.
- (4) Dress the leads connected to the switch into their original positions.
- (5) Replace the bridge chassis in the carrying case (par. 51b(11)).

**79. Replacing Terminal Board E3**

(fig. 31)

**a. Removing Terminal Board E3.**

- (1) Remove the bridge chassis from the carrying case (par. 51b(2)).
- (2) Unsolder the leads connected to the terminals (par. 67f).
- (3) Remove the two retaining screws located on the opposite side of the mounting plate, behind capacitor C27.



*Note.* The resistors mounted on the terminal board can be replaced without removing the terminal board.

*b. Installing Terminal Board E3.* Replace the terminal board by reversing the instruction in *a* above.

## **80. Replacing Rectifiers CR1, CR2, and CR3**

(fig. 31)

### *a. Removing Rectifiers.*

- (1) Remove the bridge chassis from the case (par. 51b(2)).
- (2) Unsolder rectifier wiring (par. 67f).
- (3) Remove the two screws, nuts, and washers that attach the brackets at either end of the assembled rectifiers.
- (4) Disassemble the desired rectifier by removing the mounting screw, nut, and washer that attach the rectifiers to the brackets.

*b. Installing Rectifiers.* To reassemble and replace the rectifiers, reverse the disassembly procedure given in *a* above.

## **81. Replacing POWER Switch S14 and AMP. RESPONSE Switch S16**

(fig. 31)

### *a. Removing Switches S14 and S16.*

- (1) Remove the bridge chassis from the case (par. 51b(2)).
- (2) Unsolder the switch wiring (par. 67f).
- (3) Remove the retaining nuts at the front panel; be careful not to mar the finish of the panel.
- (4) Extract the switches from the rear of the panel.

*b. Installing Switches.* To install the switches, reverse the disassembly procedure given in *a* above.

## **82. Replacing AMP. GAIN Control R65**

(fig. 31)

### *a. Removing AMP. GAIN Control.*

- (1) Remove the bridge chassis from the case (par. 51b(2)).
- (2) Unsolder the lead wires to the control (par. 67f).
- (3) Loosen the retaining screw on the side of the control knob and remove the knob.
- (4) Remove the retaining nut at the front panel; be careful not to mar the finish of the panel.
- (5) Extract the control from the rear of the panel.

*b. Installing AMP. GAIN Control.* To replace R65, reverse the disassembly procedure given in *a* above.

### **83. Replacing GENERATOR Switch S12**

(fig. 31)

#### *a. Removing GENERATOR Switch S12.*

- (1) Remove the bridge chassis from the case (par. 51b(2)).
- (2) Remove the entire rectifier assembly (par. 80).
- (3) Remove electron ray tube V2.
- (4) Loosen the two set screws on the side of the control knob with a No. 8 Allen wrench. Remove the knob.
- (5) Remove the retaining nut at the front panel. Be careful not to mar the finish of the panel.
- (6) Carefully slide the switch from the rear of the panel. Be careful not to place any undue strain on the lead wires connected to the switch.
- (7) Unsolder the lead wires to the switch (par. 67f).

#### *b. Reassembling GENERATOR Switch S12.*

- (1) Resolder the lead wires to the switch.
- (2) Replace the switch in its mounting position on the rear of the front panel.
- (3) Replace the retaining nut at the front panel. Be careful not to mar the finish of the panel.
- (4) Place the control knob on the switch shaft. Tighten one of the set screws on the side of the knob with the No. 8 Allen wrench.
- (5) Rotate the switch to the extreme counterclockwise position.
- (6) Check the position of the knob pointer. It should be positioned opposite the DC HI marking on the front panel. If necessary, loosen the knob set screw and index the pointer.
- (7) Tighten the two set screws on the side of the knob by using the No. 8 Allen wrench.
- (8) Replace the electron ray tube in its socket.
- (9) Reassemble the rectifier assembly (par. 86b).
- (10) Replace the bridge chassis in the carrying case (par. 51b(11)).

### **84. Replacing DETECTOR Switch S1**

(fig. 31)

#### *a. Removing Switch S1.*

- (1) Remove the bridge chassis from the case (par. 31b(2)).
- (2) Loosen the two set screws on the side of the control knob with the No. 8 Allen wrench and remove the knob.
- (3) Remove the entire rectifier assembly (par. 80).

- (4) Unsolder all switch wiring and the wiring to capacitor C28.
- (5) Remove the switch retaining nut at the front panel; be careful not to mar the finish of the panel.
- (6) Extract the switch from the rear of the panel.
- (7) Remove capacitor C28 from the switch (par. 85).

*b. Installing Switch S1.*

- (1) Reconnect capacitor C28 to the switch (par. 85).
- (2) Replace the switch in its mounting position at the rear of the front panel.
- (3) Replace and tighten the switch retaining nut at the front panel; be careful not to mar the finish of the panel.
- (4) Resolder the lead wires to the switch and to capacitor C28.
- (5) Replace the rectifier assembly (par. 80).
- (6) Place the control knob on the switch shaft. Tighten one of the set screws on the side of the knob with the No. 8 Allen wrench.
- (7) Rotate the switch to the extreme counterclockwise position.
- (8) Check the position of the knob pointer. It should be positioned opposite the METER marking on the front panel. If necessary, loosen the knob set screw and index the pointer.
- (9) Tighten the two set screws on the side of the knob with the No. 8 Allen wrench.

## **85. Replacing Capacitor C28**

(fig. 31)

*a. Removing Capacitor C28.*

- (1) Remove the bridge chassis from the case (par. 51b(2)).
- (2) Remove DETECTOR switch S1 (par. 84).
- (3) Remove the retaining nut and washer attaching the capacitor bracket to the switch.

*b. Installing Capacitor C28.* To install capacitor C28 in the bridge, reverse the procedure in *a* above.

## **86. Replacing Transformers T1 and T2**

(fig. 31)

*a. Removing Transformers T1 and T2.*

- (1) Remove the bridge chassis from the case (par. 51b(2)).
- (2) Unsolder the transformer lead wires (par. 67).
- (3) Remove the four nuts and lock washers that attach each transformer to the chassis.

(4) Carefully remove each transformer by pulling it straight up from the chassis.

*b. Installing Transformers T1 and T2.* To install the transformers, reverse the disassembly procedure given in *a* above.

## **87. Replacing Binding Posts**

(fig. 30)

### *a. Removing Binding Posts.*

(1) Remove the bridge chassis from the case (par. 51b(2)).

*Note.* Before replacing any or all binding posts, carefully note the color and type of binding post attached at each of the identification markings. Also note the exact location and arrangement of all grounding lugs and terminals installed with the binding posts.

(2) Unsolder the wiring to the binding posts (par. 67f).

(3) Remove the mounting nuts and lock washers from the binding posts. To keep the binding posts from turning when loosening the retaining nuts, insert a punch or similar object into the vertical holes located in the front panel side of the binding posts.

(4) Remove the identification plates after all binding posts have been removed.

*b. Installing Binding Posts.* To install a binding post, reverse the disassembly procedure given in *a* above.

## **88. Replacing PHONES Jacks J2 and J3**

(fig. 31)

### *a. Removing Phone Jacks.*

(1) Remove the bridge chassis from the case (par. 51b(2)).

(2) Unsolder the lead wires to the jacks.

(3) Remove the mounting nuts that secure the phone jacks to the front panel. Jack J2 has two insulating washers that prevent the jack from grounding to the panel. Remove and save these washers.

### *b. Installing Phone Jacks.*

(1) Replace the jacks in their respective mounting holes in the front panel. Jack J2 has an insulating washer on each side of the panel to prevent the jack from grounding. Replace these washers. Jack J3 is grounded, and has no insulating washers.

(2) Replace and tighten the mounting nuts at the rear of the panel.

(3) Connect the lead wires to the jacks.

### Section III. CALIBRATION

*Note.* Capacitance-Inductance-Resistance Test Set AN/URM-90 is calibrated during manufacture. After calibration, the controls are locked in place and recalibration is not required unless parts replacement has been necessary, or it has been definitely established that adjustments must be made. If it is impossible to obtain the recommended reading for variable resistor R25, R24, or R21, by the following adjustments, replace the affected resistor.

#### 89. Calibrating Variable Resistor R25

To check the calibration of variable resistor R25, proceed as follows:

- a. Operate the POWER switch to the OFF position.
- b. Set the circuit selector switch to L and D-Q x 1 position.
- c. Turn the Q and D-Q dial to 6.3 on the black scale.
- d. Measure the resistance from any G (ground) binding post and the C (high) binding post with Laboratory Standard AN/URM-2. Resistance should be  $10,030 \pm 100$  ohms.
- e. If adjustment is required, remove the bridge chassis from the case (par. 53c) and proceed as follows:
  - (1) Loosen the two set screws in the collar of the contact and collar assembly for R25 with the No. 10 Allen wrench.
  - (2) Rotate the contact arm along the resistance winding until the calibration is correct.
  - (3) Tighten the two set screws in the contact and collar assembly at the correct calibration point with the No. 10 Allen wrench.

#### 90. Calibrating Variable Resistor R24

To check the calibration of variable resistor R24, proceed as follows:

- a. Check to be sure the POWER switch is in OFF position.
- b. Set the circuit selector switch to the L and Q x 100 position.
- c. Turn the Q and D-Q dial to 6.3 on black scale.
- d. Measure the resistance from the center terminal of variable resistor R24 (fig. 30) to the wiper arm of switch S6 (fig. 32) that is immediately behind the front panel. Use a Laboratory Standard AN/URM-2. Resistance must be  $68 \pm 1$  ohms.
- e. If adjustment is required, remove the bridge chassis from the case (par. 51b(2)), and proceed as follows:

- (1) Loosen the two set screws in the collar of the contact and collar assembly for R24 with a No. 10 Allen wrench.
  - (2) Rotate the contact arm along the resistance winding until the calibration is correct.
  - (3) Tighten the two set screws in the contact and collar assembly at the correct calibration point with a No. 10 Allen wrench.
- f. Turn the circuit selector switch to C and D-Q x .01 position.
- g. Repeat the resistance measurement described in *d* above. Resistance must be  $100.3 \pm 1$  ohms.

### **91. Calibrating Variable Resistor R21**

To check the calibration of variable resistor R21, proceed as follows:

- a. Check to see that the POWER switch is in the OFF position.
- b. Set the circuit selector switch to the C and D-Q x 0.1 position.
- c. Turn the Q and D-Q dial to 6.3 on the black scale.
- d. Measure between the center terminals of R24 and R21 (fig. 30) with a Laboratory Standard AN/URM-2. Resistance must be  $1003 \pm 10$  ohms.
- e. If adjustment is required, remove the bridge chassis from the case (par. 51b(2)), and proceed as follows:
  - (1) Loosen the two set screws in the collar of the contact and collar assembly for R21 with a No. 10 Allen wrench.
  - (2) Rotate the contact arm along the resistance winding until the calibration is correct.
  - (3) Tighten the two set screws in the contact and collar assembly at the correct calibration point with a No. 10 Allen wrench.

## **Section IV. FINAL TESTING**

### **92. General**

This section is to be used as a reference in determining the quality of a repaired Capacitance-Inductance-Resistance Test Set AN/URM-90. The minimum test requirements outlined in paragraphs 94 through 98 should be performed by maintenance personnel with the proper test equipment (par. 93) and the necessary skills. Repaired equipment meeting these requirements should furnish uniformly satisfactory operation.

### 93. Test Equipment Required for Final Testing

The following test equipment is required for final testing the test set:

Test equipment	Technical manual
Multimeter TS-352/U	TM 11-5527
Resistance Bridge ZM-4 A/U	TM 11-2019
Frequency Meter FR-67/U	TM 11-2698
Laboratory Standard AN/URM-2	
Voltmeter ME-30A/U	

### 94. Testing 1,000 Cps Oscillator Frequency

- a. Turn the circuit selector switch to L and D-Q x 1 position.
- b. Set the LRC DIAL MULTIPLIER to the 100h position on the L scale.
- c. Turn the Q and D-Q dial to 10 on the black scale.
- d. Adjust the LRC dial to 10.00.
- e. Turn the DETECTOR switch to the INTERNAL position.
- f. Turn the GENERATOR switch to the INTERNAL position.
- g. Connect the test cable of Frequency Meter FR-67/U between the L and R (high) binding posts and the C (high) binding post (fig. 5).
- h. Move the POWER switch to the ON position. Allow at least 5 minutes for warm-up before proceeding with the measurement.
- i. Measure the oscillator frequency with the FR-67/U, which should indicate  $1,000 \pm 10$  cps.
- j. Move the POWER switch to the OFF position and disconnect the frequency meter.

### 95. Testing Oscillator Output Voltage

- a. Adjust the bridge controls as described in paragraph 94a through f.
- b. Connect the red and black test leads to Voltmeter ME-30A/U (fig. 34) as follows:
  - (1) Connect the INPUT (high) binding post of Voltmeter ME-30A/U to the C (high) binding post (fig. 5) of the bridge.
  - (2) Connect the INPUT G binding post of the voltmeter to the L and R (high) binding posts of the bridge.
- c. Turn the ME-30A/U meter range switch (fig. 34) to 30. Move the ON-OFF switch on the ME-30A/U to ON. The pilot lamp should light.
- d. Move the bridge POWER switch to ON. Allow at least 5 minutes for the equipment to warm up.

e. After the 5-minute warm-up period, the ME-30A/U should indicate a minimum of 12 volts. Reading should be made on the lower meter scale; use 10 as the multiplication factor.

f. Upon completion of the test, move both the ON-OFF switch of the ME-30A/U and bridge POWER switch to their OFF positions. Disconnect the test leads.

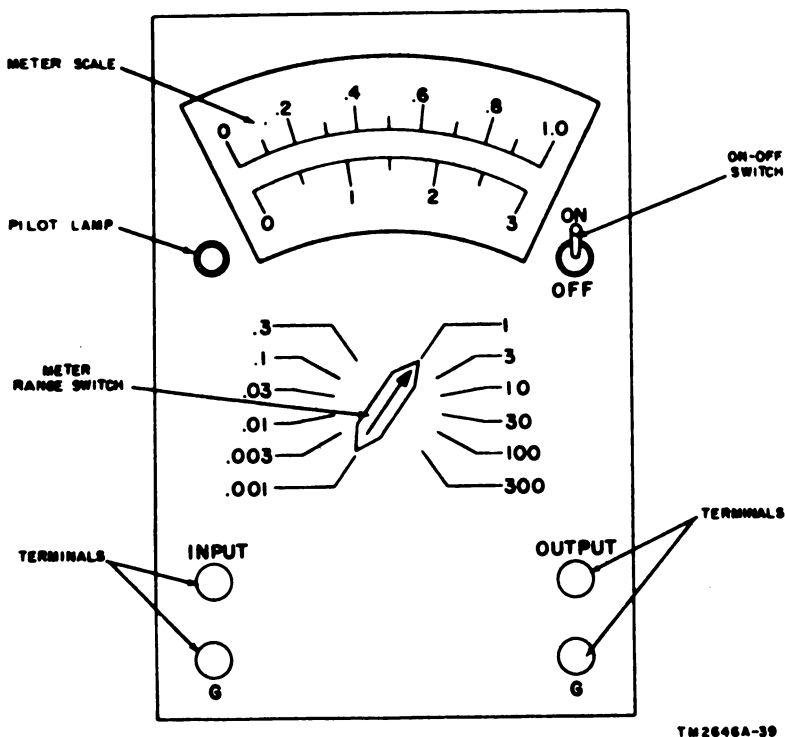

Figure 34. Voltmeter ME-30A/U, front panel view showing controls.

## 96. Testing High-voltage Dc Bridge Excitation

- a. Remove the bridge chassis from the case (par. 51b(2)).
- b. Turn the circuit selector switch to R and R x 10 position.
- c. Turn the LRC DIAL MULTIPLIER to the 100k $\Omega$  position on the R scale.
- d. Turn the DETECTOR switch to the EXTERNAL position.
- e. Turn the GENERATOR switch to the DC HI position.
- f. Turn the LRC dial to 10.00
- g. Connect the test leads from Multimeter TS-352/U to the L and R (high) and C (high) binding posts (fig. 5). Adjust the TS-352/U to measure currents of 50 milliamperes.



**Caution:** Observe the TS-352/U carefully for a reversed polarity indication, when the bridge POWER switch is turned to ON.

*h.* Connect a second Multimeter TS-352/U or equivalent across resistor R56 (fig. 31). Set the TS-352/U to read a minimum of 500 volts dc.

*i.* Watch the meter scale to insure correct polarity of connections and move the bridge POWER switch to ON. Allow 5 minutes warm-up time.

*j.* Note the reading of the first meter, (*g* above). The reading should be a minimum of 10 milliamperes.

*k.* Note the reading of the second meter connected as described in *h* above. Reading should be a minimum of 200 volts dc.

*l.* After measurements have been taken, move the bridge POWER switch to OFF. Disconnect both Multimeters TS-352/U from the bridge.

*m.* Replace the bridge chassis in the case (par. 51*b* (11)).

## 97. Testing Low-voltage Dc Bridge Excitation

*a.* Remove the bridge chassis from the case (par. 51*b*(2)).

*b.* Turn the circuit selector switch to the R and R x 10 position.

*c.* Turn the LRC DIAL MULTIPLIER to the 100k $\Omega$  position on the R scale.

*d.* Turn the DETECTOR switch to the EXTERNAL position.

*e.* Turn the GENERATOR switch to the DC LO position.

*f.* Turn the LRC dial to 10.00.

*g.* Connect Multimeter TS-352/U or equivalent test leads to the L and R (high) and C (high) binding posts. Adjust the TS-352/U to measure currents of 500 milliamperes.

**Caution:** Observe the TS-352/U carefully for reversed polarity indication when the bridge POWER switch is turned ON.

*h.* Connect a second Multimeter TS-352/U or equivalent across resistor R3 (fig. 31). Set the TS-352/U to read a minimum of 50 volts dc.

*i.* Watch the meter scale to insure correct polarity of connection and move the bridge POWER switch on the test set to ON. Allow 5 minutes warm-up time.

*j.* Note the reading of the first meter (*g* above). The reading should be a minimum of 250 milliamperes.

*k.* Note the reading of the second meter connected as described in *h* above. Reading should be a minimum of 10 volts dc.

*l.* After measurements have been taken, move the bridge POWER switch to OFF. Disconnect both Multimeters TS-352/U from the bridge.

*m.* Replace the bridge chassis in the case (par. 52*b*(11)).

## 98. Testing Bridge Accuracy

a. Testing the accuracy of the bridge requires the use of certain standard resistors, capacitors, and inductors (*c* below). The standard capacitors and inductors are included in Laboratory Standard AN/URM-2, which must be used in conjunction with these tests. The standard resistor is Resistance Bridge ZM-4A/U.

b. Test the test set for accuracy by connecting the calibration standards (*c* below) to the test set and obtaining a bridge balance through the applicable operating procedure (par. 18, 23, or 26). When testing for capacitance and inductance accuracy, operate the GENERATOR and DETECTOR switches to their INTERNAL positions. Each test reading lists two balance readings for the LRC dial. Check each balance position. Refer to paragraph 17 for starting procedure and paragraph 44 for stopping procedure.

c. The following chart lists the calibration standards used to test the accuracy of the bridge at various settings of the circuit selector switch and LRC DIAL MULTIPLIER.

Calibration standard	Switch position		Normal balance positions of LRC dial			Allowable error in percentage
	Circuit selector	LRC DIAL MULTIPLIER	Outer dial ring	Middle dial ring	Inner dial ring	
.1 ohm	R x 1	0.1	1.	0	0	±.35
			0.	9	10	
10. ohms	R x 1	1	10.	0	0	±.15
			9.	9	10	
100. ohms	R x 10	1	10.	0	0	±.15
			9.	9	10	
1,000. ohms	R x 10	10	10.	0	0	±.15
			9.	9	10	
10,000. ohms	R x 10	100	10.	0	0	±.15
			9.	9	10	
100,000. ohms	R x 10	1k	10.	0	0	±.15
			9.	9	10	
100,000. ohms	R x 1	10k	10.	0	0	±.15
			9.	9	10	
100,000. ohms	R x 1	100k	1.	0	0	±.15
			0.	9	10	
1,000. uuf	D-Q x .1	.01 uf	1.	0	0	±.5
			0.	9	10	
100. mh	D-Q x 1	10 mh	10.	0	0	±.1
			9.	9	10	

## CHAPTER 7

# SHIPMENT AND LIMITED STORAGE AND DEMOLITION TO PREVENT ENEMY USE

---

### Section I. SHIPMENT AND LIMITED STORAGE

#### 99. Disassembly

The following instructions are recommended as a guide for preparing the test set for transportation and storage:

- a. Remove the power plug from the ac outlet.
- b. Disconnect any external attachments to the binding posts of the test set.
- c. Wind the power cable around the control knobs on the panel.
- d. Remove the tube shield and stow it in the storage compartment located in the cover of the test set. Check the contents of the storage compartment for completeness (par. 10). Close the storage compartment cover and secure it with the locking screw.
- e. Place the cover on the bridge and close the spring-type latches.

#### 100. Repacking for Shipment or Limited Storage

The exact procedure for repacking depends on the material available and the conditions under which the equipment is to be shipped or stored. Use the procedures outlined below whenever possible. The information covering the original packaging (par. 9 and fig. 3) will also be helpful.

a. *Limited Storage.* The AN/URM-90 requires no further repacking for limited storage except for placing a package of desiccant inside the cover before closing it.

b. *Shipment.*

- (1) *Material requirements.* The following materials are required for packaging the AN/URM-90:

Material	Quantity
<b>Barrier, waterproof material</b>	17 sq ft
<b>Tape, pressure-sensitive</b>	3 ft
<b>Paper, corrugated, single-faced, flexible</b>	20 sq ft
<b>Tape, gummed paper</b>	12 ft
<b>Strapping, flat steel</b>	10 ft
<b>Wooden shipping box</b>	1 ea

- (2) *Box size.* The box is 10 inches high, 22 inches wide, and 14 inches deep. Eleven board feet of lumber is used to construct the box. The packed weight is 57 pounds and the volume is 1.8 cubic feet.
- (3) *Packaging and stowing tubes, spare parts and tools.* Wrap the tubes individually in flexible, single-faced, corrugated paper. Secure the wrapping with gummed paper tape. Stow the tubes, spare parts, and tools within the compartment located inside the cover of the AN/URM-90. Fill all voids with flexible, single-faced, corrugated paper to prevent shifting during transport. Close the cover and secure the fasteners.
- (4) *Packaging AN/URM-90.* Cushion the closed AN/URM-90 on all sides with pads made from flexible, single-faced, corrugated paper so that shock normally encountered in handling and transit will be absorbed. Secure the cushioning with gummed paper tape. Inclose the cushioned case within a wrap of flexible, single-faced, corrugated paper and seal all closures with gummed paper tape. Make a snug conforming wrap.
- (5) *Repackaging technical manual.* Put the technical manual in a close-fitting bag made of waterproof barrier material. Use the pressure-sensitive tape to completely seal all joints, seams, and openings.
- (6) *Packing.* Pack the packaged AN/URM-90 in the nailed wooden box. Fabricate the wooden box to fit the contents snugly and line it with a waterproof case liner made from the waterproof barrier material. Place the packaged AN/URM-90 inside the nailed wooden box and waterproof case liner. Fill all voids with pads of flexible, single-faced, corrugated paper. Place the packaged technical manuals on top of the packaged unit. Close the waterproof case liner and seal it with the pressure-sensitive tape. Nail the top on the wooden box. Use the flat steel strapping around boxes intended for intertheater shipment.

## Section II. DEMOLITION OF MATERIEL TO PREVENT ENEMY USE

### 101. General

The demolition procedures outlined in paragraph 102 will be used to prevent the enemy from using or salvaging this equipment. Demolition of the equipment will be accomplished only upon order of the proper authority.

### 102. Methods of Destruction

*a. Smash.* Smash the panel controls, tubes, coils, switches, capacitors, resistors, and meter; use sledges, axes, handaxes, pickaxes, hammers, crowbars, or heavy tools.

*b. Cut.* Cut power cord, test leads, and wiring; use axes, handaxes, or machetes.

*c. Burn.* Burn cords and manuals; use gasoline, kerosene, oil, flame throwers, or incendiary grenades.

*d. Bend.* Bend panel and chassis.

*e. Explosives.* If explosives are necessary, use firearms, grenades, or TNT.

*f. Disposal.* Bury or scatter the destroyed parts in slit trenches, foxholes, or other holes, or throw them into streams.

**CAPACITOR COLOR CODE MARKING  
(MIL-STD CAPACITORS)**

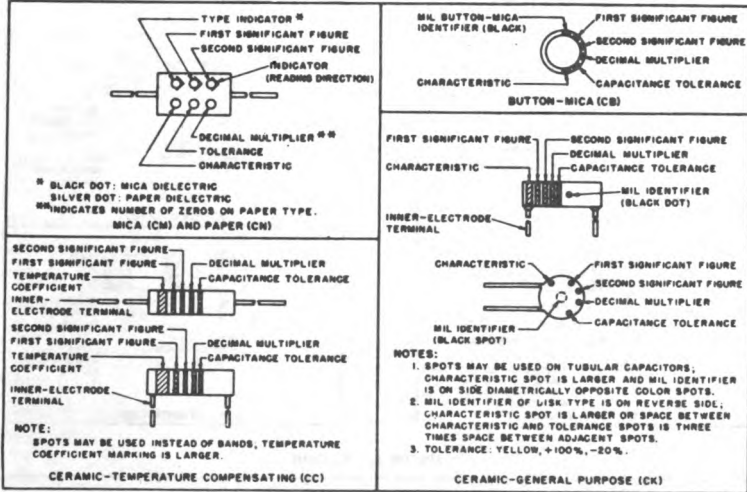

**CAPACITOR COLOR CODE**

COLOR	SIG FIG.	MULTIPLIER		CHARACTERISTIC				TOLERANCE $\pm$				TEMPERATURE COEFFICIENT (UUF/UF/°C)	
		DECIMAL	NUMBER OF ZEROS	CM	CN	CB	CK	CM	CN	CB	CC		
BLACK	0	1	NONE		A			20	20	20	20	2	ZERO
BROWN	1	10	1	B	E	B	W					1	-30
RED	2	100	2	C	H	X	Z					2	-80
ORANGE	3	1,000	3	D	J	D			30				-180
YELLOW	4	10,000	4	E	P								-280
GREEN	5		5	F	R						5	0.5	-330
BLUE	6		6	S									-470
PURPLE (VIOLET)	7		7	T	W								-790
GRAY	8		8	X									+30
WHITE	9		9								10	1	-330 ( $\pm 900$ ) <sup>3</sup>
GOLD		0.1						5		5			+100
SILVER		0.01						10	10	10			

1. LETTERS ARE IN TYPE DESIGNATIONS GIVEN IN MIL-C SPECIFICATIONS.  
 2. IN PERCENT, EXCEPT IN UUF FOR CC-TYPE CAPACITORS OF 10 UUF OR LESS.  
 3. INTENDED FOR USE IN CIRCUITS NOT REQUIRING COMPENSATION.

STD-C1

*Figure 35. MIL-STD capacitor color codes.*

**RESISTOR COLOR CODE MARKING  
(MIL-STD RESISTORS)**

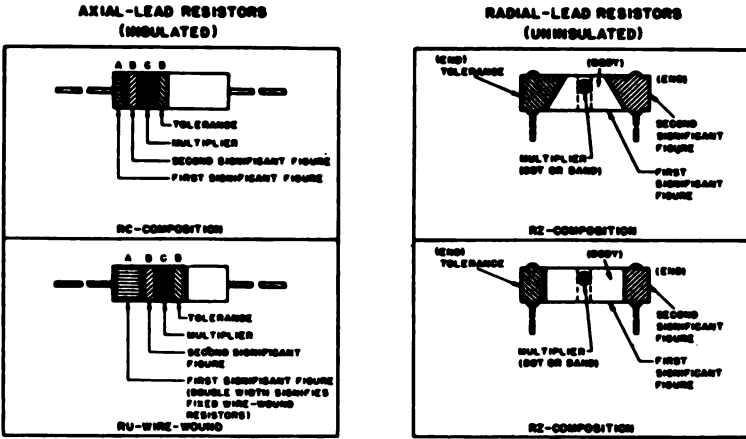

**RESISTOR COLOR CODE**

BAND A OR BODY <sup>a</sup>		BAND B OR END <sup>a</sup>		BAND C OR DOT OR BAND <sup>a</sup>		BAND D OR END <sup>a</sup>	
COLOR	FIRST SIGNIFICANT FIGURE	COLOR	SECOND SIGNIFICANT FIGURE	COLOR	MULTIPLIER	COLOR	RESISTANCE TOLERANCE (PERCENT)
BLACK	0	BLACK	0	BLACK	1	BODY	± 20
BROWN	1	BROWN	1	BROWN	10	SILVER	± 10
RED	2	RED	2	RED	100	GOLD	± 5
ORANGE	3	ORANGE	3	ORANGE	1,000		
YELLOW	4	YELLOW	4	YELLOW	10,000		
GREEN	5	GREEN	5	GREEN	100,000		
BLUE	6	BLUE	6	BLUE	1,000,000		
PURPLE (VIOLET)	7	PURPLE (VIOLET)	7		*		
GRAY	8	GRAY	8	GOLD	0.1		
WHITE	9	WHITE	9	SILVER	0.01		

<sup>a</sup> FOR WIRE-WOUND-TYPE RESISTORS, BAND A SHALL BE DOUBLE-WIDTH. WHEN BODY COLOR IS THE SAME AS THE BODY (OR BANDS) OR END COLOR, THE COLORS ARE DIFFERENTIATED BY SHADE, GLOSS, OR OTHER MEANS.

**EXAMPLES (BAND MARKINGS):**

10 OHMS ± 20 PERCENT: BROWN BAND A; BLACK BAND D; BLACK BAND C; NO BAND B.  
 4.7 OHMS ± 5 PERCENT: YELLOW BAND A; PURPLE BAND B; GOLD BAND C; GOLD BAND D.

**EXAMPLES (BODY MARKINGS):**

10 OHMS ± 20 PERCENT: BROWN BODY; BLACK END; BLACK BODY OR BAND; BODY COLOR OR TOLERANCE END.  
 1,000 OHMS ± 10 PERCENT: ORANGE BODY; BLACK END; RED DOT OR BAND; SILVER END.

STD-81

*Figure 36. MIL-STD resistor color codes.*

# INDEX

	<i>Paragraph</i>	<i>Page</i>
<b>A</b>		
<b>Ac resistance measurements:</b>		
At 1,000 cps .....	21	19-21
Frequencies other than 1 kc .....	31	32
With reactance .....	32	32-33
<b>Accuracy:</b>		
Ac resistance measurements .....	22	21-22
Capacitance measurements at 1,000 cps .....	24	25-26
Dc resistance measurements .....	20	19
Dissipation factor measurements at 1,000 cps .....	25	26-27
Inductance measurements at 1,000 cps .....	27	30
Storage factor measurements at 1,000 cps .....	28	31
Additional equipment required .....	8	5
AMP. GAIN control, replacing .....	82	90
AMP. RESPONSE switch, replacing .....	81	90
<b>Amplifier:</b>		
Detection signal .....	62	68-69
Oscillator .....	60c	62
<b>B</b>		
<b>Binding posts:</b>		
Replacing .....	87	93
Use .....	16	14
<b>Bridge:</b>		
Description .....	7a	4
Network circuit .....	61	65-68
Ratio dials, function .....	14	9-12
Testing accuracy .....	98	99
<b>C</b>		
<b>Calculating:</b>		
Ac resistance .....	21j	20
Capacitance at 1,000 cps .....	23j	22
Dc resistance .....	18i	16
Dissipation factor at 1,000 cps .....	23k	24
Inductance at 1,000 cps .....	26j	27
Parallel capacitance of capacitors .....	33h	34
Parallel resistance of capacitors .....	33i	34
Storage factor at 1,000 cps .....	26k	30
<b>Calibrating variable resistor:</b>		
R21 .....	91	95
R24 .....	90	94-95
R25 .....	89	94



	<i>Paragraph</i>	<i>Page</i>
<b>Capacitance:</b>		
Bridge circuits .....	61c	66
Measurements at 1,000 cps .....	23	22-25
Standard, use as .....	41	40
C2, replacing .....	72	84
C26 and C27, replacing .....	73	85-86
C28, replacing .....	85	92
Using bridge as standard .....	41	40
Characteristics, technical .....	4	2-3
Chart, trouble-shooting .....	69	78-82
Checking equipment .....	10	8
Checking for shorts .....	68	76-78
Check list, equipment performance .....	56	53-58
<b>Circuit:</b>		
Bridge network .....	61	65-68
Detection .....	63	71-72
Detection signal amplifier .....	62	68-69
Oscillator-amplifier .....	60	62
Power supply .....	59	61-62
Selector switch, use .....	14a	9
Common names .....	5	3
Components .....	6	3
Controls and instruments, use of .....	15	12-14
Corrections for internal resistance .....	19	18-19

## D

<b>DA Form:</b>		
11-238, use of .....	47b	43
11-239, use of .....	51a	46
Daily preventive maintenance .....	47b	43
Data, trouble-shooting .....	65	74-75
Dc generator, external, use with .....	30	31-32
Dc resistance measurements .....	18	15-18
Description of test set .....	7	4
Destruction, methods of .....	102	102
Detection circuits .....	63	71-72
DETECTOR switch, replacing .....	84	91-92
Disassembly .....	99	100

## E

Electrolytic capacitors, measuring .....	35	35
Electron ray tube detector circuit .....	63a	71
<b>Equipment:</b>		
Additional required .....	8	5
Checking .....	10	8
Common names .....	5	3
Installing .....	11	8
Performance check list .....	56	53-58
Uncrating and unpacking .....	9	7
Extending range of Q and D-Q dial .....	38b	36
<b>External:</b>		
Dc generator, use with .....	30	31-32

	<i>Paragraph</i>	<i>Page</i>
<b>External—Continued</b>		
Dc power source, use with .....	29	31
Detector, use with .....	21e	19

## F

Final testing, test equipment .....	93	96
First echelon maintenance:		
Materials required .....	46	43
Scope of .....	45	43
Forms and records .....	2	1
Fuse replacement and location .....	58	59

## G

<b>Galvanometer:</b>		
Detector circuit .....	63c	71
Replacing .....	74	86-87
Use, measuring small direct currents .....	43	41
General precautions .....	67	75-76
GENERATOR switch, replacing .....	83	91

## H

Headset, use as detector .....	21e	19
--------------------------------	-----	----

## I

Indications, short circuit .....	68b	76
Inductance:		
Bridge circuit:		
Hay .....	61e	67-68
Maxwell .....	61d	67
Measurements at 1,000 cps .....	26	27-30
Inductors, resonant frequency of .....	37	35-36
Inspection, visual .....	53	49
Installing equipment .....	11	8
Instruments, controls and .....	15	12-14
Internal resistance, correction for .....	19	18-19
Isolating shorts .....	68d	78

## J

Jacks, binding posts, use .....	16	14
---------------------------------	----	----

## L

<b>LRC dial:</b>		
Normal use .....	14c	11
Use as calibrated resistor .....	39	39-40
LRC DIAL MULTIPLIER, use .....	14b	11
Lubrication .....	48	45

## M

<b>Measurements:</b>		
Ac resistance with reactance .....	32	32-33

	<i>Paragraph</i>	<i>Page</i>
<b>Measurements—Continued</b>		
Dc resistance .....	18	15-18
Frequencies of 1,000 cps:		
Ac resistance .....	21	19-21
Capacitance .....	24	25-26
Dissipation factor .....	25	26
Inductance .....	26	27-30
Storage factor .....	26 <i>k</i>	30
Frequencies other than 1,000 cps:		
Ac resistance .....	31	32
Capacitance and inductance .....	30	31-32
Dissipation and storage factors .....	38	36-39
Parallel capacitance and resistance of capacitors .....	33	34
Measuring:		
Electrolytic capacitors .....	35	35
Terminal capacitance of shielded inductors .....	36	35
Three-terminal capacitors .....	34	34-35
METER SHUNT switch, replacing .....	78	89
Methods of destruction .....	102	102
Monthly preventive maintenance .....	51 <i>b</i>	46

O

OSC. GAIN control, replacing .....	75	87
Oscillator:		
External generator, use as .....	42	41
Testing frequency .....	94	96
Oscillator-amplifier circuit .....	60	62
Oscillator-filter assembly, replacing .....	77	88-89
Operator's preventive maintenance .....	47	43-45

P

Packaging data .....	9 <i>a</i>	7
Panel controls, common names .....	5	3
Parts, replacement of .....	71	82-84
Parts replacement, precautions .....	67 <i>f</i>	75
PHONES jacks, replacing .....	88	93
Pilot lamp, replacing .....	57	59
Power source, external dc, use of .....	29	31
Power supply circuit .....	59	61-62
POWER switch, replacing .....	81	90
Precautions, general .....	67	75-76
Preventive maintenance:		
Operator's .....	47	43-45
Organizational repairman's .....	51	46-48
Purpose and use .....	3	2

Q

Q and D-Q dial:		
Extending range .....	38 <i>b</i>	36
Use .....	14 <i>d</i>	12

R

<b>Ratio dials, bridge, use of</b> .....	14	9-12
<b>Records, forms and</b> .....	2	1
<b>Rectifiers, replacing</b> .....	80	90
<b>Repacking</b> .....	100	100-101
<b>Repairman's:</b>		
<b>Maintenance:</b>		
Scope .....	48	45
Tools, materials, and test equipment .....	49	45
Preventive maintenance .....	51	46-48
Trouble-shooting techniques .....	52	48-49
<b>Replacement of parts</b> .....	71	82-83
<b>Replacing:</b>		
AMP. GAIN control .....	82	90
AMP. RESPONSE switch .....	81	90
Binding posts .....	87	93
Capacitor C2 .....	72	84
Capacitor C28 .....	85	92
Capacitors C26 and C27 .....	73	85-86
DETECTOR switch .....	84	91-92
Fuse .....	58	59
Galvanometer .....	74	86-87
GENERATOR switch .....	83	91
METER SHUNT switch .....	78	89
OSC. GAIN control .....	75	87
Oscillator-filter assembly .....	77	88-89
PHONES jacks .....	88	93
Pilot lamp .....	57	59
POWER switch .....	81	90
Rectifiers .....	80	90
Resistors on terminal board E2 .....	76	87-88
Terminal board E3 .....	79	89-90
Transformers .....	86	92-93
Tubes .....	54	49-50
<b>Resistance:</b>		
Bridge circuit .....	61b	66
<b>Measurements:</b>		
Ac .....	20	19
Dc .....	18	15-18
Transformers .....	70	82
<b>Resistors, replacing</b> .....	76	87-88
<b>Resonant frequency, determining</b> .....	37	35-36

S

<b>Scope</b> .....	1	1
<b>Scope of:</b>		
First echelon maintenance .....	45	43
Repairman's maintenance .....	48	45
<b>Shipment, repacking for</b> .....	100	100-101
<b>Shorts, B+ and filament circuits</b> .....	68	76-78

	<i>Paragraph</i>	<i>Page</i>
<b>Special tools:</b>		
Description .....	7d	4
Supplied with test set .....	50	46
Service upon receipt of used equipment .....	12	8
Starting procedure .....	17	15
Stopping procedure .....	44	42

## T

Technical characteristics .....	4	2-3
Terminal board E3, replacing .....	79	89-90
<b>Test equipment:</b>		
Final testing .....	93	96
Trouble shooting .....	66	75
Test leads, description .....	7b	4
Test set, description .....	7	4
<b>Testing:</b>		
Bridge accuracy .....	98	99
Bridge excitation:		
High voltage .....	96	97-98
Low voltage .....	97	98
Oscillator frequency .....	94	96
Three-terminal capacitors, measuring .....	34	34-35
<b>Transformers:</b>		
Replacing .....	86	92-93
Resistance .....	70	82
<b>Trouble shooting:</b>		
Chart .....	69	78-82
Data .....	65	74-75
Equipment performance check list, using .....	55	51-52
Precautions .....	67	75-76
Procedures .....	64	73-74
Repairman's techniques .....	52	48-49
Test equipment required .....	66	75
Tubes .....	54	49-50
Tube shield, description of .....	7c	4
Tubes, trouble shooting and replacing .....	54	49-50

## U

Use, purpose and .....	3	2
Used equipment, service upon receipt .....	12	8

## V

<b>Variable resistor, calibration of:</b>		
R21 .....	91	95
R24 .....	90	94-95
R25 .....	89	94
Visual inspection .....	53	49
Voltmeter ME-30A/U, use as detector .....	21e	19

## W

Weekly preventive maintenance .....	47c	44-45
-------------------------------------	-----	-------

DEPARTMENT OF THE ARMY  
Washington 25, D. C., 25 April 1956

TM 2646A is published for the use of all concerned.

[AG113.6 (25 Apr 56)]

By Order of *Wilber M. Brucker*, Secretary of the Army:

MAXWELL D. TAYLOR  
*General, United States Army,*  
*Chief of Staff.*

Official:

JOHN A. KLEIN,  
*Major General, United States Army,*  
*The Adjutant General.*

DISTRIBUTION:

Active Army:

NSA (1)  
CNGB (1)  
ASA (3)  
Tec Svc, DA (1) except  
CSIGO (30)  
Tec Svc Bd (1)  
Hq CONARC (5)  
CONARC Bd (Incl ea Test  
Sec) (1)  
Army AA Comd (2)  
OS Maj Comd (5)  
OS Base Comd (5)  
Log Comd (5)  
MDW (1)  
Armies (5)  
Corps (2)  
Tng Div (2)  
Ft & Cp (2)  
Gen & Br Svc Sch (5)  
except Sig Sch (25)  
Gen Depots (2) except  
Atlanta Gen Depot (None)  
Sig Sec, Gen Depots (10)  
Sig Depots (20)  
POE (OS) (2)

Army Terminals (2)  
Trans Terminal Comd (2)  
OS Sup Agencies (2)  
Sp Wpn Comd (2)  
Sig Fld Maint Shops (3)  
ACS (3)  
Sig Lab (5)  
Army Elct PG (1)  
Mil Dist (1)

Units organized under following  
TOE:

11-7C, Sig Co, Inf Div (2)  
11-16C, Hq & Hq Co, Sig Bn,  
Corps or Abn Corps (2)  
11-57R, Armd Sig Co (2)  
11-127R, Sig Rep Co (2)  
11-128R, Sig Depot Co (2)  
11-500R (AA-AE), Sig Svc  
Org (2)  
11-557C, Abn Sig Co (2)  
11-587R, Sig Base Maint Co (2)  
11-592R, Hq & Hq Co, Sig Base  
Depot (2)  
11-579R, Sig Base Depot Co (2)

NG: State AG (6); Units — same as Active Army except allowance is one copy to each unit.

USAR: None.

For explanation of abbreviations used, see SR 320-50-1.



**NOTES:**

RESISTANCES ARE IN OHMS, CAPACITANCES ARE IN UF.

☐ INDICATES EQUIPMENT MARKING.

SECTION S5 IS VIEWED FROM REAR.

SECTION 1 OF SWITCH S6 IS CLOSEST TO CONTROL

RESISTORS S4 AND S8, AND VARIABLE RESISTOR COMPRISE THE [LRC] DIAL.

[GENERATOR] SWITCH S1 AND [GENERATOR] SWITCH ARE VIEWED FROM REAR. SECTION 1 OF SECTION S12 IS CLOSEST CONTROL KNOB.

[GENERATOR] SWITCH IS SHOWN IN [METER] POSITION.

[GENERATOR] SWITCH IS SHOWN IN [DC HI] POSITION.

CONTACTS MADE IN EACH POSITION OF SWITCH S5 ARE ALLOWED.

SWITCH POSITION			CONTACT
L	R	C	
0.1mh	0.1Ω	100uf	1
1mh	1Ω	10uf	2
10mh	10Ω	1uf	3
100mh	100Ω	0.1uf	4
1h	1kΩ	0.01uf	5
10h	10kΩ	0.001uf	6
100h	100kΩ	0.0001uf	7

SECTION S7 CLOSES WHEN S6 IS IN THE [L] AND [KI] POSITION.

SOLD LINE INDICATES JUMPER PLACED BETWEEN [D-0] BINDING POSTS, WHEN EXTERNAL DECADE RESISTOR IS NOT CONNECTED.

TN2648A-1E





**ES:**

**THOSE OF T1 AND T2 ARE  
RENCE ONLY AND DO NOT**

**NAL TO WHICH THE LEAD**

**SECTION AND IS NUMBERED THE SAME AS ADJACENT STATION.  
IAL.**

**GAGE SOLID WIRE. ALL OTHER  
BUSS WIRE.**

**RU I) ON TERMINAL BOARD E2 (STATIONS 21 AND 12)  
AND BEAR THE SAME IDENTIFICATION LETTER ON**

**TM2646A-43**





PIN : 029215-000

Digitized by Google