



JUL 29 1993

Mobile Communications

**MVS™
SYNTHESIZED MOBILE RADIO
136-174 MHz, 40 WATT MOBILE
COMBINATION**

TABLE OF CONTENTS

RF BOARD	LBI-31920
PA BOARD	LBI-31921
AUDIO BOARD	LBI-31922
LOGIC BOARD	LBI-38899
SYSTEM BOARD	LBI-31924
FRONT CAP ASSEMBLY	LBI-38387
SERVICE SECTION	LBI-31926

TABLE OF CONTENTS

SPECIFICATIONS	3
SYSTEM	3
TRANSMITTER	4
RECEIVER	4
COMBINATION NOMENCLATURE	5
GENERAL DESCRIPTION	6
EQUIPMENT AND FEATURES	7
AVAILABLE OPTIONS	9
OPERATION	10
TWO CHANNEL OPERATION	10
16/128 CHANNEL OPERATION	11
SCAN OPERATION	12
RECEIVER SCAN RATE	12
TO PROGRAM SCAN CHANNELS & SELECT PRIORITY	13
USING RADIO WITH SCAN	14
PC PROGRAMMING SCAN OPTIONS	16
DETAILED SCAN OPERATION	17
PUBLIC ADDRESS OPTION OPERATION	19
TYPE 99 OPTION OPERATION	19
DETAILED TYPE 99 OPERATION	19
PROGRAMMING CONNECTION	23
MECHANICAL PARTS BREAKDOWN	24
PARTS LIST	25
INTERCONNECTION DIAGRAM	27

SPECIFICATIONS*

SYSTEM

RADIO TYPE	MVS
FREQUENCY RANGE: Transmit and Receive	136.0 to 153.0 MHz (Lo Split) 150.0 to 174.0 MHz (Hi Split)
Frequency Separation Transmit and Receive	17 MHz (Lo Split) 24 MHz (Hi Split)
Voltage	13.8 Vdc ±20%
Battery Drain: Receiver (13.8 Vdc) Off Squelched Unsquelched Transmitter (13.6 Vdc)	0.01 Amperes (maximum) 0.65 Amperes (maximum) 1.00 Amperes (maximum at 3 Watts audio) 9.5 Amperes (maximum at 40 Watts RF)
Frequency Stability	±5 ppm (±2.5 ppm optional)
Channel Spacing	30 kHz
Frequency Capacity	2, 16, or 128 channels
Temperature Range	-30°C (-22°F) to +60°C (+140°F)
Duty Cycle	100% Receive, 20% Transmit (EIA Duty Cycle)
Dimensions (Less Accessories) Height Width Depth	(Fits a DIN size dash opening) 54.5 mm (2.15 inches) (body)/62.5 mm (2.46 inches) (nose) 181.5 mm (7.15 inches) 216 mm (8.5 inches)
Weight (Less Accessories)	20.4 kg (4.5 pounds)
Military Specifications	

STANDARD	METHODS/PROCEDURES	
	MIL-STD-810-C	MIL-STD-810-D
Low Pressure	500.1/Procedure 1	500.2/Procedure 1
High Temperature	501.1/Procedure 1, 2	501.2/Procedure 1, 2
Low Temperature	502.1/Procedure 1	502.2/Procedure 1, 2
Temperature Shock	503.1/Procedure 1	503.2/Procedure 1
Solar Radiation	505.1/Procedure 1	505.2/Procedure 1
Humidity	507.1/Procedure 2	507.2/Procedure 2
Vibration	514.2/Procedure 8, 10	514.3/Procedure 1
Shock	516.2/Procedure 1, 2, 3, 5	516.3/Procedure 1, 3, 4, 5, 6

TRANSMITTER

Power Output	40 Watts typical (35 Watts minimum)
Conducted Spurious	75 dB Below Carrier (typical)
Modulation	±5.0 kHz (maximum)
Audio Sensitivity	40 millivolts (typical)
Audio Frequency Characteristics (Per RS-152B)	Within +1 dB to -3 dB of 6 dB/octave pre-emphasis from 300 Hz to 3000 Hz per EIA standards. Post limiter filter per FCC and EIA.
FM Noise	-53 dB (typical, companion receiver method)
Power Adjust Range	20 to 40 Watts
Distortion	2% (typical)
Deviation Symmetry	0.1 kHz (typical)
RF Output Impedance	50 ohms
Carrier Attack Time	50 milliseconds (maximum)
Audio Attack Time	50 milliseconds (maximum)

RECEIVER

Audio Ampl Output (4-ohm speaker)	3 Watts (less than 5% distortion) EIA
Sensitivity: 12 dB SINAD (EIA method)	-118 dBm (0.28 microvolts) (typical)
Selectivity: (EIA two-signal method)	-84 dB ±30 kHz (typical)
Spurious Response	-80 dB (maximum)
Intermodulation	-80 dB typical (12 dB SINAD)
Hum and Noise: Squelched	-80 dB (typical)
Unsquelched	-53 dB (typical)
Modulation Acceptance	±7 kHz
Frequency Response	Within +2.0 dB and -8 dB of a standard 6 dB/octave de-emphasis curve from 300 to 3000 Hz EIA
RF Input Impedance	50 ohms
Receiver Attack Time	40 milliseconds, typical @ 8 dB SINAD 100 milliseconds, maximum
Receiver Recovery Time	100 milliseconds, typical @ 8 dB SINAD 250 milliseconds, maximum

* Refer to the appropriate Specification Sheet for the complete specifications.

COMBINATION NOMENCLATURE

Digits 1 & 2	Digit 3	Digit 4	Digit 5	Digit 6	Digit 7	Digit 8
Product Code	Radio Package	Frequency Band	Frequency Split	Control Panel	Channel Spacing	RF Power Output
NP	F Front Mount	H High Band	1 Low Split, High Band (136-153 MHz)	O None	S Standard	S Standard Power
			3 High Split, High Band (150-174 MHz)			

GENERAL DESCRIPTION

The Ericsson GE mobile radio is a synthesized, wideband radio, utilizing microcomputer technology to provide high reliability, high quality, and high performance in two-way, FM, mobile communications. The 150-174 MHz MVS radio provides 40 Watts RF output power with allowable channel separation of 24 MHz transmit and 24 MHz receive. The 136-153 MHz MVS provides 40 Watts with 17 MHz channel separation.

The MVS radio is easy to operate with large buttons for function selection and an easily viewed liquid crystal display (LCD). The control panel and the LCD are back-lighted for night operation.

All radio functions are stored in a programmable electrically erasable PROM (EEPROM). Channel selection, volume setting, scan channels, and scan on-off function are all permanently remembered even when the 12V battery is disconnected.

Seven interchangeable control panels are available for upgrading and adding options to the radio. The plug in control panel modules can provide 2 channels, 16 or 128 channels with scan, Type 99 decoding, and Public Address.

The radio is normally mounted in a conventional configuration with the entire unit under the dash or in a DIN size opening inside the dash. A remote mount option allows controlling the main radio assembly remotely from the Front Cap Assembly.

The receiver is able to scan on both noise squelch operation and Channel Guard (tone or digital). The scan rate is fast, requiring only 15ms per channel (66 channels/second). A 16 channel radio will scan the priority channels every 90ms (11 times/sec) and the non-priority channels every 330ms (3 times/sec). The scan time will be faster when fewer channels are programmed into the scan memory.

The microphone is equipped with a Channel Guard hookswitch which disables Channel Guard whenever the microphone is removed from its holder.

The radio is programmed using an IBM compatible personal computer equipped with a RS-232 serial interface connector. A GE supplied RS-232 interface box and cable are also required. The computer can program or reprogram the customer frequencies, Channel Guard, carrier control timer, and other programmable customer options. Programming is done through the microphone jack without opening the radio.

A temperature compensated oscillator module provides $\pm 0.0005\%$ (5 PPM) oscillator stability. An optional $\pm 0.00025\%$ (2.5 PPM) high stability oscillator is available.

The MVS radio consists of the following assemblies:

- RF Board
- PA Board
- Audio Board
- Logic Board
- System Board
- Front Cap Assembly

The boards are all mounted onto a main casting assembly with easy access to each for servicing. Interconnect plugs and ribbon cables are used to interconnect the boards eliminating problems with pinched wires when replacing covers.

RF BOARD

The RF Board includes the synthesizer, the transmitter, and the receiver circuits.

Synthesizer Circuit

The synthesizer generates all transmit and receive RF frequencies. The synthesizer frequency is controlled by the microprocessor located on the Logic Board. Frequency stability is maintained by a temperature compensated reference oscillator module. Transmit audio, which is processed on the Audio Board, feeds the synthesizer to modulate the VCO. The buffered VCO output drives both the transmitter exciter and the receiver mixer.

Transmitter Circuit

The transmitter consists of a fixed-tuned exciter module, a PA module, a power control circuit, a PIN diode antenna switch, and a low pass filter.

The PA module is capable of 10 Watts output to drive the PA Board. The power control circuit controls the PA module by sampling the PA Board output to maintain constant output power across the band.

The RF output level is internally adjustable for rated power. A thermistor in the control protects the PA from overheating.

Receiver Circuit

The dual conversion receiver circuit consists of a front end section, 45 MHz first IF, a 455 kHz second IF,

and a FM detector. All audio processing and squelch functions are accomplished on the Audio Board.

PA BOARD

The PA Board amplifies the RF Board PA module output to the rated output of 40 Watts. The 40 Watt output is fed back to the RF Board where the power control circuit, the antenna switch, and the low pass filter are located.

AUDIO BOARD

The Audio Board provides all audio and tone processing for the receiver and transmitter, except the receiver volume control and 3 watt audio PA. The board also contains the internally adjustable receiver squelch circuit. The Audio Board obtains all control signals from the Logic Board.

LOGIC BOARD

The Logic Board contains the microprocessor and associated memory circuits which include an EPROM for controlling the processor and a programmable "personality" electrically erasable PROM (EEPROM) to store customer frequencies, tones, and options. The microprocessor provides tone generation and detection, frequency data to the synthesizer, and sends and receives data to another microprocessor in the front cap assembly for the LCD display and the control panel commands.

SYSTEM BOARD

The System Board controls the main input power to the radio. The front panel POWER switch and the IGNITION SENSE input lead provide the necessary signals to the MOSFET switching circuit.

The board also interfaces all option connections from the internal boards in the radio with the optional items outside of the radio. All options that apply to the radio, interconnect to the System Board through the back of the radio using an optional cable.

FRONT CAP ASSEMBLY

The Front Cap Assembly contains the Control Board, Control Panel, LCD Assembly, and houses the internal speaker.

The Control Board contains a microprocessor which interfaces the control panel keyboard and a LCD module to two serial data lines for communication with the main radio microprocessor on the Logic Board. The Control

Board also contains a digital volume control and a 3 watt audio power amplifier.

EQUIPMENT AND FEATURES

MICROPHONE

The standard mobile combinations use a transistorized dynamic microphone with an internal Channel Guard hookswitch. The microphone is housed in a sturdy case, and the extendable coiled cord plugs onto a jack on the bottom of the radio. The microphone is secured to the radio by a cable clamp. A magnetic microphone hanger is supplied with the microphone. The Channel Guard is disabled when the microphone is removed from the magnetic hanger allowing the operator to monitor the channel before sending a message. Optional DTMF and desk microphones are available.

CARRIER CONTROL TIMER (CCT)

The Carrier Control Timer turns off the transmitter after the microphone push-to-talk (PTT) switch has been keyed for a pre-programmed time period. A pulsing alert tone will warn the operator to unkey and then rekey the PTT to continue the transmission. The timer can be programmed to time out for 30 seconds to 7.5 minutes in 30 second increments. The timer can be enabled or disabled for each channel.

CHANNEL GUARD

Channel Guard provides a means of restricting calls to specific radios through the use of a continuous tone coded squelch system (CTCSS) or a continuous digital coded squelch system (CDCSS). Tone frequencies range from 67.0 Hz to 210.7 Hz in 0.1 Hz steps. There are 83 standard programmable digital codes. The Channel Guard tone frequencies and codes are software programmable. Both tone frequencies and digital codes may be mixed on each channel. These codes and frequencies are listed in Table 1.

SQUELCH TAIL ELIMINATION (STE)

STE is used with tone and digital Channel Guard to eliminate squelch tails. The STE burst is transmitted when the microphone PTT is released. The receiving radio decodes the burst and mutes the receiver audio for 250ms. This mute time allows the transmission to end and to mute the squelch tail. The radio looks for STE on the received signal when the microphone is either on or off hook. The STE is enabled for transmit and/or receive by PC programming the radio's personality.

Table 1 - Tone & Digital Channel Guard

TONE CG	DIG. CG	DIG. CG	DIG. CG
No. CG	023	261	654
67.0	025	263	662
71.9	026	265	664
74.4	031	271	703
77.0	032	306	712
79.7	043	311	723
82.5	047	315	731
85.4	051	331	732
88.5	054	343	734
91.5	065	346	743
94.8	071	351	754
97.4	072	364	036*
100.0	073	365	053*
103.5	074	371	122*
107.2	114	411	145*
110.9	115	412	
114.8	116	413	212*
118.8	125	423	225*
123.0	131	431	246*
127.3	132	432	252*
131.8	134	445	255*
136.5	143	464	266*
141.3	152	465	274*
146.2	155	466	325*
151.4	156	503	332*
156.7	162	506	356*
162.2	165	516	446*
167.9	172	532	452*
173.8	174	546	454*
179.9	205	565	455*
186.2	223	606	462*
192.8	226	612	523*
203.5	243	624	526*
210.7	244	627	
	245	631	
	251	632	

* Codes Unique to General Electric

NOTE

To reverse the polarity of the digital Channel Guard codes, type I ("inverted") before the code number, i.e. I023.

AVAILABLE OPTIONS

CONTROL PANELS

The Control Panel plugs into the Front Cap Assembly and determines the number of channels (2 without scan, 16 or 128 with scan), the Type 99 decode option, or the Public Address option.

The panel is made of highly durable plastic with rounded corners and recessed controls for passenger safety requirements.

There are 7 different optional interchangeable control panels available:

- Option CP01 2 Channel (19B801450P1)
- Option CP02 2 Channel with Type 99 decode (19B801450P2)
- Option CP03 16 Channel with scan (19B801450P3)
- Option CP04 16 Channel with scan and Public Address (19B801450P4)
- Option CP05 128 Channel with scan (19B801450P5)
- Option CP06 2 Channel with Public Address (19B801450P6)
- Option CP07 16 Channel with scan and Type 99 decode (19B801450P7)

The Public Address Control Panels include a relay (19C851585P6) for automatic switching of the public address audio to an external speaker. The 128 channel Control Panel includes a larger memory EEPROM to replace U704 on the Logic Board. Refer to the Installation Manual.

PC PROGRAMMING OPTIONS

The radio is programmed using an IBM compatible personal computer equipped with a RS-232 connector. Option TQ3310 provides the RS-232 serial interface unit and the cable between the PC and the unit. (An auxiliary power supply for the unit is also included which is not needed to program the MVS.) Option TQ3315 provides the MVS programming cable between the PC interface unit and the MVS microphone jack. Option TQ3318 provides the MVS programming software to run on the PC.

NOISE SUPPRESSION KIT OPTION

Noise Suppression Kit Option PD01 (19A148539G1) is available for installations where excessive alternator or electrical noises present on the power cable do not permit the radio to operate properly. Refer to the interconnect diagram.

AC POWER SUPPLY OPTIONS

To use the radio as a base station, Option PS01 (19A704647P2) 121 Volt AC, 60 Hertz, 13A power supply is available. The standard nine foot power cable supplied with the radio is connected to the mating connector on the power supply. In addition, Option PS02 (19A704647P3) 120/240 Volt AC, 50/60 Hz, 13A supply is also available where its use is dictated. DC remote control may be provided with either supply.

OPTION CABLE

Option Cable Option CC01 (19C851585P3) is used to bring all option connections from the System Board through the back of the radio to the outside. This cable is required with all external options.

UNIVERSAL TONE CABLE

Universal Tone Cable Option CC02 (19C851585P5) equipped with a 9-pin Winchester connector is required when an external tone encoder or decoder is used. The tone cable interconnects the tone encoder/decoder with the radio through the option cable Option CC01. Refer to the installation diagrams in this manual for jumper modifications. A second "Y" cable is required when both encode and decode functions are used (Option CC04).

POWER CABLE

20 foot power cable Option CC03 (19B801358P4) is available for installations requiring more than the standard 9 foot cable.

EXTERNAL SPEAKER OPTIONS

The external speaker options provide a five inch speaker in a LEXAN housing. Option LS01 (19C850550G10) provides a dash mount and Option LS02 (19C850550G11) provides a window mount. The radio's 3 watt amplifier drives the speaker's 3.2 ohm impedance. The speaker leads are connected to pins 2 and 9 of option cable Option CC01. When the External Speaker is used, refer to the Installation Instructions and Interconnection diagram for jumper modifications.

EXTERNAL ALARM FOR T-99

External Alarm Relay Option SU01 (19A705499P1) is used with the Type 99 Control Panel options. The relay requires External Alarm ON/OFF switch Option SU02

(19C851585P7) and connects to pin 13 of option cable Option CC01. The relay can sound the vehicle horn when a Type 99 call is received. The alarm switch is used to turn the horn relay on or off.

PUBLIC ADDRESS RELAY

The Public Address Relay switch (19C851585P6) is supplied with the Public Address Control Panel Option and requires an external speaker and option cable Option CC01. The relay provides automatic switching of the public address audio to an external speaker when the microphone is keyed. Also, a switch on the relay allows selecting the receiver audio to feed either the internal speaker or the external speaker. The relay may be ordered separately from the PA Control Panels as Option SU03 for use as an internal/external speaker switch. The public address relay connects to P2 of the option cable.

REMOTE MOUNT

Remote mount Option CB01 (19A705306G1 & G2) allows controlling the main radio assembly remotely from the Front Cap Assembly. The Front Cap is removed from the main radio assembly and mounted to a rear housing containing an interface board (supplied with the option). A new front cap (without any controls or displays) containing an interface board is mounted to the radio assembly. A system cable (normally 18 feet supplied) is used between the two units. A 20 foot power cable is also supplied for the radio assembly.

DC REMOTE CONTROL OPTION

The DC Remote Control Board Option CY01 (19A704686P7) is used to interface with a remote control console and mounts inside the AC Power Supply Option. The board provides remote single frequency transmit and receive and Channel Guard disable control. The board connects to P2 of the option cable Option CC01.

SERVICE OPTIONS

Test Point Adapter box Option TQ2370 (19B801494P1) allows receive audio monitoring and transmit audio injection without opening the radio. The adapter connects between the microphone and the radio, providing test points for all 10 pins of the microphone connector.

Service Cable 19A704875P1 provides an extension between the Audio Board and the Logic Board. Both sides of the Audio Board are available for servicing using the cable.

Service cable 19B801348P4 provides a 2 foot extension between the 9 pin "D" connectors (J701 and P701) on the Logic Board and Control Board. The Front Cap Assembly may be serviced using this cable.

To allow easier servicing of the Front Cap Assembly, service cable 19A705235P2 provides a longer ribbon cable (2 feet) between the System Board and the Control Board connectors J902 and J901. This longer cable is not required for most serving. The radio's ribbon cable is usually adequate in length if the cable is not looped through the front of the radio's assembly.

OPERATION

This section provides a description of the Control and Indicator functions. The section is divided into two subsections: 2 Channel Operation, and 16/128 Channel Operation. Complete operating instructions for the radio are provided in the Operator's Manual.

TWO CHANNEL OPERATION

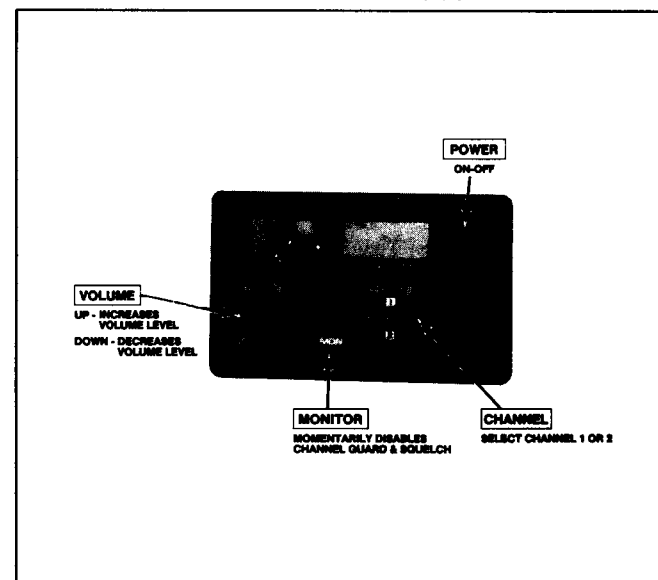

CONTROLS

POWER

A momentary type switch to turn the radio on or off. Press once to turn the radio on; press again to turn the radio off. Power ON is indicated by all indicators on the LCD being activated momentarily, and then a channel number being displayed.

VOLUME

Momentary type switches to adjust the volume. Press and hold the (up arrow) to increase the volume. Press and hold the (down arrow) to decrease the volume. While on an inactive channel, beeps are heard while adjusting

the volume. No beeps are heard while listening to an active channel.

MONITOR (MON)

A momentary type switch to allow monitoring of the selected channel before transmitting a message. It disables Channel Guard and squelch and will allow audio noise if the channel is not busy. This may be convenient when setting the volume to the desired level.

CHANNEL

Two push type switches. Press Channel 1 to select channel 1; press Channel 2 to select channel 2. The channel number will be shown on the display.

INDICATORS

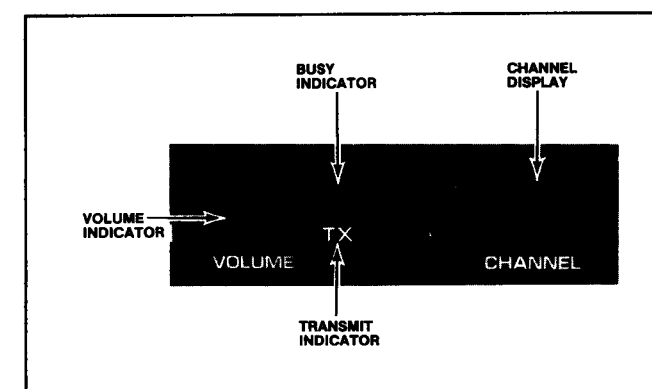

CHANNEL DISPLAY

Displays the current operating channel.

BUSY (BSY)

Illuminates if the channel displayed is in use.

TRANSMIT TX

Illuminates whenever the Push-To-Talk (PTT) button is pressed. Goes out when it is released.

VOLUME INDICATOR

Functions as a bar graph to indicate relative volume level. As the volume is increased, more segments are illuminated.

OPTION (OPT)

Illuminates whenever an option is turned on.

16/128 CHANNEL OPERATION

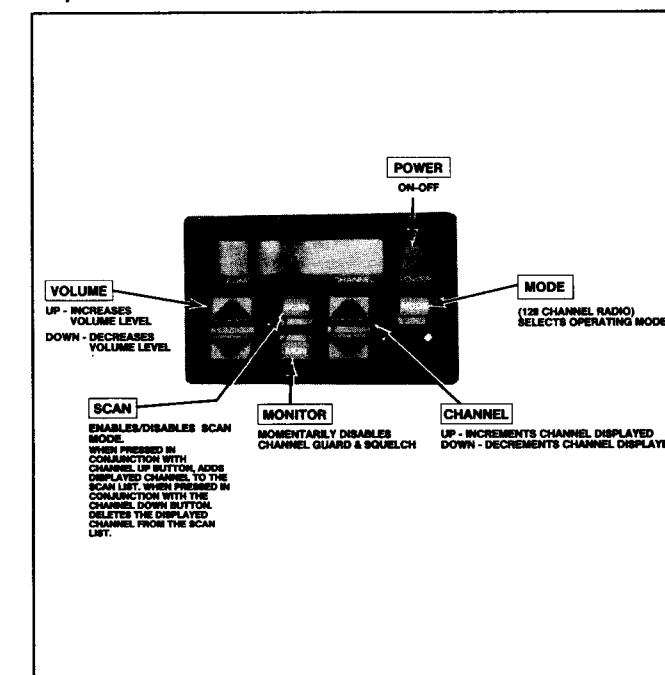

CONTROLS

POWER

A momentary type switch to turn the radio on or off. Press once to turn the radio on; press again to turn the radio off. Power ON is indicated by all indicators on the LCD being activated momentarily and then a channel number being displayed.

VOLUME

Momentary type switches to adjust the volume. Press and hold the (up arrow) to increase the volume. Press and hold the (down arrow) to decrease the volume. While on an inactive channel, beeps are heard while adjusting the volume. No beeps are heard while listening to an active channel.

MONITOR (MON)

A momentary type switch to allow monitoring of the displayed channel before transmitting a message. It disables Channel Guard and squelch and will allow audio noise if the channel is busy. This may be convenient when setting the volume to the desired level.

CHANNEL

Two push type switches. Press CHANNEL (up arrow) to increase the channel number; press CHANNEL (down arrow) to decrease the channel number. The channel

number will be shown on the display. Unprogrammed channels will be skipped.

SCAN

A momentary type switch to turn the scan function on or off when used in conjunction with the CHANNEL switch it enables the ADD/DELETE Function to allow the scan list to be modified. When turned on, the display will show "SCN" in the lower center portion of the display.

MODE

A momentary type switch used in the 128 channel models only. These models can contain up to 8 modes with each mode containing up to 16 channels. When the switch is pressed once, the operating mode will increment one mode. If continuous pressure is applied, the mode will increment to mode 8 then back to mode 1. Unprogrammed modes will be skipped.

INDICATORS

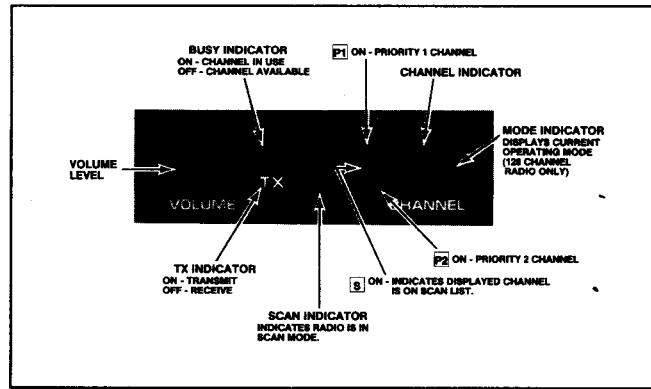

CHANNEL DISPLAY

Displays the current operating channel. In scan operation when a carrier is detected on a channel, that channel is displayed.

PRIORITY 1 (P1)

Illuminates when the channel displayed is a Priority 1 scan channel.

PRIORITY 2 (P2)

Illuminates when the channel displayed is a Priority 2 scan channel.

(S)

Illuminates when the channel displayed is a non-priority scan channel.

SCAN (SCN)

Illuminates when the scan function is activated. Blinks when the microphone is off-hook to indicate the radio has stopped scanning.

BUSY (BSY)

Illuminates if the channel displayed is in use.

TRANSMIT TX

Illuminates whenever the Push-To-Talk PTT button is pressed. Goes out when it is released.

VOLUME INDICATOR

Functions as a bar graph to indicate relative volume level. As the volume is increased, more segments are illuminated.

MODE DISPLAY

Displays the current mode in a 128 channel radio.

OPTION (OPT)

Illuminates whenever an option is turned on.

SCAN OPERATION

The SCAN functions allows monitoring of up to 16 receive channels. The scanned channels may be any frequency within the frequency band limits of the radio and may be Channel Guard protected (tone or digital). All scan functions are retained in memory, even if the 12 Volt battery is disconnected.

Any channel may be scanned with or without a priority level. One channel may be programmed for Priority 1 (P1) and another for Priority 2 (P2) with any or all remaining channels programmed as non-priorities.

When using the scan function with a 128 channel radio, the scan function works on a per mode basis. Only the current operating mode will be scanned. Scan must be turned off before changing modes.

RECEIVER SCAN RATE

The scan rate for the radio will vary depending upon the number of channels programmed into the scan list and whether or not Channel Guard is programmed. When scanning 16 inactive channels, the priority channels are sampled 11 times/second and the non-priority

channels 3 times/second. The scan rate will be faster when fewer channels are programmed into scan memory.

Scan operation will be determined by the following conditions:

- **PRIORITY 1, PRIORITY 2 AND NON-PRIORITY PROGRAMMED**

The Priority 1, Priority 2 and up to 14 remaining channels will be scanned. Once a carrier is detected (and if programmed the correct Channel Guard is decoded), the LCD display will indicate that channel. Sampling of the Priority 1 and Priority 2 channels continues while receiving a message. Should a Priority 1 or 2 channel carrier (and correct Channel Guard) be detected while a non-priority channel is being received, the applicable indicator, P1 or P2 lights, and the channel is switched to the Priority 1 or 2 channel regardless of what is being received on the non-priority channel.

- **NON-PRIORITY PROGRAMMED**

Up to 16 non-priority channels may be scanned. Once a carrier is detected (or correct Channel Guard is decoded) the digital display will indicate the channel. Scan will stop and remain on the channel until the carrier disappears; after a few seconds scanning resumes. The channels are scanned in descending order.

TO PROGRAM SCAN CHANNELS AND SELECT PRIORITY

The selection of scan channels and priority is front panel programmable using the SCAN switch in conjunction with the CHANNEL UP and DOWN switches.

NON-PRIORITY (S)

1. Confirm that the radio is turned on. If not press the POWER switch.
2. If SCAN indicator is lit, press and release the SCAN switch to disable scan function.
3. Select the desired channel using the CHANNEL UP and DOWN switch.
4. Press and hold the SCAN switch, then press the CHANNEL UP switch once to add the channel to the scan list. The S indicator will be shown in the display to indicate that the channel is now in the scan program.
5. Release SCAN switch.

6. Repeat steps 2 through 5 for each channel (up to 16) to be added to the scan list.

PRIORITY 2 (P2)

1. With scan off, select the desired P2 channel.
2. Press and hold SCAN switch; then press the CHANNEL UP switch twice. The displayed channel will now become the Priority 2 channel and the P2 indicator will light to indicate that the channel is now in the scan list as priority 2.
3. Release the SCAN switch.

NOTE

A previous channel with priority will become a non-priority scan channel when a new priority channel is programmed.

PRIORITY 1 (P1)

The Priority 1 channel may be added to the scan list by one of three methods by PC programming the radio's personality. Normally P1 is added using the front control panel (Method 1).

- **Method 1: FRONT PROGRAMMABLE**

1. With scan off, select the desired P1 channel.
2. Press and hold SCAN switch; then press the CHANNEL UP switch three times. The displayed channel will now become the Priority 1 channel and the P1 indicator will light to indicate that the channel is now in the scan list as priority 1.
3. Release the SCAN switch.

- **Method 2: FIXED P1 OPTION**

The P1 channel is PC programmed into the radio's personality.

- **Method 3: SELECTED CHANNEL OPTION**

This option is PC programmed into the radio's personality. Each time the scan function is turned on by pushing the SCAN switch, the P1 channel becomes the channel in the display (the SELECTED channel).

DELETE SCAN CHANNEL (S,P1,P2)

1. Confirm that the radio is on. If not, press the power switch.

2. If SCN indicator is lit, press and release SCAN switch to disable scan function.
3. Select the desired channel to be removed from the scan list using the CHANNEL UP or DOWN switches.
4. Press and hold SCAN switch; then press the CHANNEL DOWN switch once. This removes the selected channel from the scan list. All scan indicator (S,P1,P2 and SCN) will be off.
5. Release SCAN switch.
6. Repeat preceding Steps 2 thru 5 for each channel to be removed from the scan list.

REVIEWING THE SCAN LIST

1. Confirm that the radio is turned on. If not, press the POWER switch.
2. If SCAN indicator is lit, press and release SCAN switch to disable scan function.
3. Select each channel (one at a time) using the CHANNEL UP or DOWN switch and confirm channels included on the scan list. The scan indicators (S, P1, P2) will light for each channel programmed.

USING THE RADIO WITH SCAN

THE SELECTED CHANNEL

The SELECTED channel is the channel in the display when scan is turned on by pushing the SCAN switch. When a signal is not being received, the radio reverts to this channel for transmitting. When a signal is being received, the radio can be PC programmed to either revert to the SELECTED channel or remain on the received channel.

The SELECTED channel does not necessarily have to be a channel in the scan list. The SELECTED channel will be temporarily entered into the scan list and scanned until the SELECTED channel is changed.

When scan is turned off by pushing the SCAN switch, the radio will return to the SELECTED channel.

DISPLAY

Channel Indicator

While no signal is being received, the channel indicator will always show the SELECTED channel. When an active channel is received, the channel indicator will show the received channel.

SCN Indicator

When the SCAN button is pushed, the radio will light the SCN indicator and begin scanning. The SCN indicator will flash when the microphone is placed off-hook to show the radio is no longer scanning (only if the radio is PC programmed not to scan off-hook).

TRANSMITTING WHILE IN SCAN

Transmitter operation in scan is determined by the PC programming of the radio's personality. A flow chart is provided in this section to summarize the scan operation described below.

Off-Hook Scan Not Enabled (default):

With off-hook scan not enabled (normal default condition), all scanning will stop when the microphone is placed off-hook. The SCN indicator will flash to show all scanning has stopped. If a signal is not being received when the mic is placed off-hook, the radio will transmit on the SELECTED channel. If a signal is being received when the mic is placed off-hook, the radio can be PC programmed (using the "scan transmit option") to either stay on the receive channel or revert to the SELECTED channel. When the mic is placed back on-hook, the radio will immediately start scanning, even if the received channel was still active.

Off-Hook Scan Enabled:

With off-hook scan enabled, moving the microphone off-hook will not affect scan operation. The radio will continue scanning. If a signal is not being received, the radio will transmit on the SELECTED channel. If a signal is being received, the radio can be PC programmed (using the "scan transmit channel" option) to either stay on the receive channel or revert to the SELECTED channel when the mic PTT is keyed.

MONITOR SWITCH OPERATION IN SCAN

The MON switch does not operate while scanning inactive channels. When a channel becomes active, the MON switch operates only during the scan hang time after the channel activity disappears.

CHANNEL CHANGES IN SCAN

Pushing the channel switches (UP or DOWN) while scan is turned on will change the SELECTED channel assignment. If a signal is being received and the channel switches are pushed, the radio will revert to the new SELECTED channel assignment. The channel indicator display will show the new assignment. After 2 seconds, if no activity appears on the new SELECTED channel, scanning will resume. If the SELECTED channel is changed to a channel not in the scan list, the new channel will be

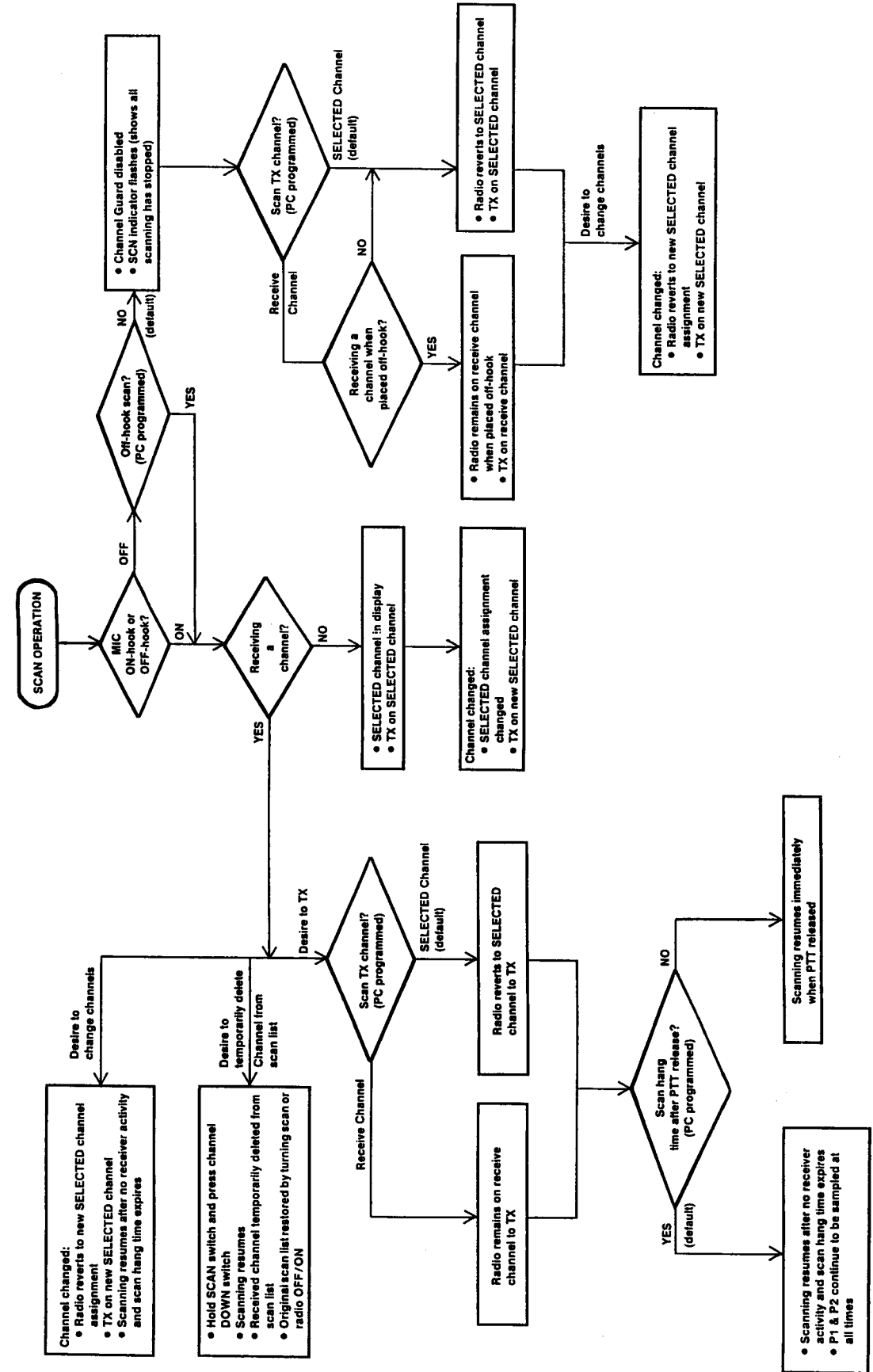

temporarily added to the scan list until the SELECTED channel is changed again.

Temporary Channel Deletions

The SCAN function must be turned off to make any permanent changes (additions, deletions, re-prioritizations) to the scan list. While in scan, temporary channel deletions may be made to the scan list. The original scan list will be back in effect by either turning scan off (by pushing the SCAN switch) or by turning the radio power off and back on.

When the radio stops scanning on an active channel, the channel may be temporarily deleted by holding the SCAN switch and then pressing the CHANNEL DOWN switch. The radio will immediately resume scanning while skipping over the temporarily deleted channel.

Temporary deletions cannot be made until the radio stops on an active channel. P1 and P2 channels cannot be temporarily deleted.

PC PROGRAMMING SCAN OPTIONS

1. Scan Hang Time:

A scan hang time is applied after the carrier on an active channel disappears and after releasing the transmitter PTT. The hang time prevents momentary signal fades from resuming scan (which would cause big gaps in the receive audio) and allows time to respond to a received call. The hang time also prevents the radio from immediately leaving the channel and resuming scan when the PTT is released to allow time for a return call. The scan hang time is normally 2 seconds in length and PC programmable from 0.3 to 5 seconds on 0.1 second steps. If no other channel activity occurs during this time, scanning will then resume. The priority channels are still being sampled during the hang time.

2. Hang After PTT Release:

YES (default): If off-hook scan is enabled, after the PTT is released, the radio will stay on channel for the length of the scan hang time (if no signal is received).

NO: if off-hook scan is enabled, when the PTT is released, the radio will not stay on channel but will immediately resume scanning. The scan hang time will still be applied after a received carrier disappears.

3. Scan For Channel Guard:

YES: The radio will stop scanning only on active channels with the correct Channel Guard. If a scan channel has no Channel Guard programmed, the radio will scan only on noise squelch operation for that channel.

NO: The radio will ignore Channel Guard and scan only on noise squelch operation.

4. Scan Transmit Channel:

SELECTED channel (default): The radio will always revert to the SELECTED channel when the mic PTT is keyed or when the mic is placed off-hook (if off-hook scan is disabled).

Receive channel: If a signal is being received, the radio will remain on the channel when the mic PTT is keyed or when the mic is placed off-hook (if off-hook scan is disabled). If signal is **not** being received, the radio will transmit on the SELECTED channel.

5. Off-Hook Scan Enable:

NO (default): The radio will stop scanning and flash the SCN indicator when the mic is off-hook. See the "scan transmit channel" description above to program where the radio will transmit.

YES: The radio will continue scanning with the mic off-hook. See the "scan transmit channel" description above to program where the radio will transmit.

6. Priority 1 Channel Programming:

The P1 channel may be added to the scan list by one of three methods:

- **Method 1 - Front programmable (default):**
P1 is added to the scan list using the front Control Panel.
- **Method 2 - Fixed P1 Option:**
The P1 channel is PC programmed into the radio's personality.
- **Method 3 - SELECTED channel option:**
The P1 channel follows the SELECTED channel. Each time the scan function is turned on by pushing the SCAN switch, the P1 channel will then follow any changes in the SELECTED channel assignment when the channel switches are pushed.

DETAILED SCAN OPERATION

The scan operation is controlled by the Logic Board, and provides for scanning any or all of up to 16 channels. The scanned channels may be located anywhere within the frequency band of the radio, and can include two priority channels (P1 and P2).

If desired, all 16 channels can be scanned with or without priority level. When SCAN is enabled, scanning of the selected channels starts immediately. Scan time is approximately 15 to 160 milliseconds per channel, depending upon whether Channel Guard has been programmed for a particular scan channel. If a carrier is not detected, the scan time is 15 milliseconds. If a carrier is detected and Channel guard is programmed for the channel, time is 75-175 milliseconds, depending upon how close the Channel Guard tone is to the desired tone. Typical value is less than 175 milliseconds.

Priority 1 (P1) and Priority 2 (P2) channels, if present, are not part of the non-priority channel scan list (S1, S2, S3, ...) and are treated separately. If there is no activity on any of the scanned channels, then the scan sequence is as shown in the following examples.

Example 1: (More than four Non-Priority channels, i.e., six channels)
P1-P2-S6-S5-S4-S3-P1-P2-S2-S1-S6-S5-P1-P2-S4-S3-S2-S1-P1-P2-...

Example 2: (Four or less Non-Priority channels, i.e., three channels)
P1-P2-S3-S2-S1-P1-P2-S3-S2-S1-P1-P2-S3-S2-S1-P1-P2-S3-S2-S1-...

Therefore, the scan sequence is: Scan P1 and P2 if programmed. Then scan up to four non-priority channels before scanning P1 and P2 again. If more than 4 non-priority channels exist, then scan will wrap around, continuously scanning four channels of the non-priority list between each P1, P2 scan sequence. If the number of non-priority channels is less than or equal to four, then all non-priority channels will be scanned between each P1, P2 scan.

As an added example, consider channels 1-8 to be the scanned channels, with P1 being Channel 1 and P2 being Channel 8. The scanning order then would be:

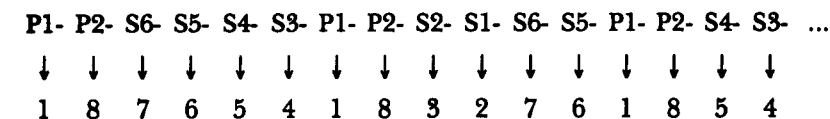

Since it takes approximately 15 to 160 milliseconds to scan each channel, then each Priority channel is sampled every 0.09 to 0.96 seconds and the Non-Priority channels are sampled at least once every 0.12 to 1.28 seconds. If Channel Guard is programmed for a channel but no carrier is detected, the scan time for that channel is 15 milliseconds.

SCANNING (Stopped On A Valid SCAN Channel):

Once a carrier is detected, the Channel display will indicate that channel. If the channel is a Non-Priority channel, and there are no Priority channels, then scanning is halted. If only a Priority 2 (P2) channel is present, then it is scanned every 5 seconds if it has Channel Guard programmed and carrier is detected, and every second otherwise. If there is only a Priority 1 (P1) channel, then it is sampled every 2.5 seconds if it has Channel Guard and carrier is detected, and every 500 milliseconds otherwise. If there are P1 and P2 Priority channels, the sample rate will vary.

In order to show the various scan conditions, the following conditions are used:

NOTE

The following conditions are shown while listening to a Non-Priority channel. "ts" is the "hole" or audio blanking time in the signal being heard while the radio is checking the priority channels for activity.

CONDITION 1: P1 and P2 have Channel Guard programmed

- a. No carriers detected on P1 or P2
P1-P1-P2-P1-P1-P2-P1-P1-P2-...
tb (time between samples) =500 msec
ts (time of sample) =32 msec
- b. Carrier on P1 detected/wrong Channel Guard
P1-P2-P2-P2-P2-P2-P1-P2-P2-P2-P2-P1-P2-...
tb=1 second
ts=32 msec for P2
75-175 msec for P1
- c. Carrier on P2 detected/wrong Channel Guard
P1-P2-P1-P1-P1-P1-P1-P1-P1-P1-P2-P1-...
tb=500 milliseconds
ts=32 milliseconds for P1
75-175 milliseconds for P2
- d. Carrier on P1 and P2 detected/both wrong Channel Guard
P1-P1-P2-P1-P1-P2-P1-P1-P2-...
tb=2.5 seconds
ts=75-175 msec
- e. Carrier on P1 and right Channel Guard
Stop scan, display P1
- f. Carrier on P2 and right Channel Guard
Display P2, scan P1
P1-P1-P1-P1-P1-P1-...
tb=500 msec
ts=32 msec
- g. Carrier on P2 with right Channel Guard, carrier/wrong Channel Guard on P1
P1-P1-P1-P1-P1-...
tb=2.5 seconds
ts=75-175 msec

CONDITION 2: Priority 1 has Channel Guard programmed, Priority 2 does not.

- a. No carriers detected on P1 or P2
P1-P1-P2-P1-P1-P2-P1-P1-P2-...
tb (time between samples) =500 msec
ts (time of sample) =32 msec
- b. Carrier on P1 detected/wrong Channel Guard
P1-P2-P2-P2-P2-P2-P1-P2-P2-P2-P2-P1-P2-...
tb=1 second
ts=32 msec for P2
75-175 msec for P1
- c. Carrier on P1 detected/right Channel Guard
Stop on P1, stop scan

d. Carrier on P2

Stop on P2, scan P1
P1-P1-P1-P1-...
tb=500 seconds
ts=32 msec

e. Carrier on P2 and P1 with wrong Channel Guard on P1

Stop on P2, scan P1
P1-P1-P1-P1-P1-P1-...
tb=2.5 seconds
ts=75-175 msec

CONDITION 3: P2 has Channel Guard, P1 does not

- a. No carriers detected on P1 or P2
P1-P1-P2-P1-P1-P2-P1-P1-P2-...
tb (time between samples) =500 msec
ts (time of sample) =32 msec
- b. Carrier on P2 detected/wrong Channel Guard
P1-P2-P1-P1-P1-P1-P1-P1-P1-P1-P2-P1-...
tb=500 milliseconds
ts=32 msec for P1
75-175 msec for P2
- c. Carrier on P2 detected/right Channel Guard
Stop on P2, scan P1
P1-P1-P1-P1-P1-P1-...
tb=500 msec
ts=32 msec
- d. Carrier on P1 detected
Stop on P1, stop scan

CONDITION 4: P1 and P2 with no Channel Guard

- a. No carriers detected on P1 or P2
P1-P1-P2-P1-P1-P2-P1-P1-P2-...
tb (time between samples) =500 msec
ts (time of sample) =32 msec
- b. Carrier on P2
Display P2, scan P1
P1-P1-P1-P1-P1-P1-...
tb=500 msec
ts=32 msec
- c. Carrier on P1
Stop on P1, stop scan

PUBLIC ADDRESS OPTION OPERATION

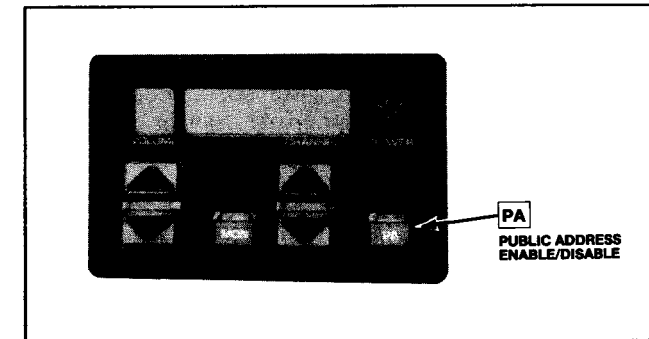

Public Address Option

If the Public Address Option is present, the radio may be used as public address amplifier. Press the PA button to enable the option (Scan must be off). The LCD will show "OPT" in the upper center portion of the display. When the mic is keyed, the radio no longer transmits, but allows the mic audio to feed the speaker. Adjust the VOLUME for desired level. Press the PA button a second time to disable the option. The OPT indicator will go out. Changing channels or turning scan on will also turn the option off.

The Public Address microphone audio normally feeds an external speaker. An ON/OFF switch, which is mounted on or near the radio, allows selecting either the internal or external speaker for the receiver audio. The ON/OFF switch turns the receiver audio on or off to the external speaker. This switch still functions for the receiver audio with the PA option disabled.

TYPE 99 OPTION OPERATION

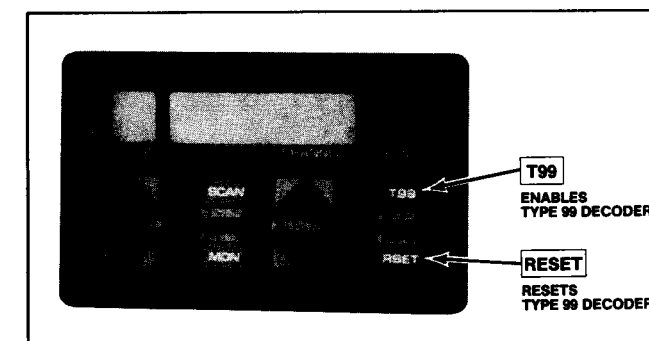

If the Type 99 Option is present, individual selective calling is possible. Press the T99 button to enable the decoder option. (Scan must be off). The LCD will show "OPT" in the upper center portion of the display. When

a call is received, an alert tone will be heard and the OPT indicator will flash continuously. After receiving the call, press the RESET button to reset the decoder for the Next call. The OPT indicator will stop flashing.

To disable the decoder, press the T99 button while the OPT indicator is on continuously. The OPT indicator will go out. If a call was received and the OPT is flashing, the RESET button must first be pushed before the T99 button will turn off the decoder.

If the Horn Alert option is present with the Type 99 option, the radio can beep the vehicle horn when a Type 99 call is received. This option permits alerting persons out of the vehicle when a call is received. The Horn ON/OFF switch which is mounted on or near the radio, is used to turn off the horn beep relay.

DETAILED TYPE 99 OPERATION AND PROGRAMMING

The optional Type 99 Control Panel provides individual, group, and super group call decode. The Motorola Formatted two-tone sequential signalling schemes can also be decoded.

In Type 99 Tone systems, calls will not be heard from the receiver until the proper two tones are detected. When the second tone is decoded and recognized as correct, an alert tone sound during the remaining portion of the second tone. The receiver audio path opens and remains open to receive messages until the decoder is reset. The OPT indicator will also flash to show a call has been received.

The MVS radio can be PC programmed with up to three separate tables of tones. Either the GE Type 99 format or the Motorola format can be assigned to each tone table. The tone decoder can be enabled individually for each channel. Once enabled, one of the three tone tables can be selected for each channel. After choosing a tone table, the call formats must be specified: Individual, Group, and Super Group for the GE format or Individual, Group and Quick Call for the Motorola format.

The Group Call format allows communications with all radios within a subgroup. The Super Group Call (in GE tone systems) or Quick-Call (in Motorola tone systems) allows communication between all radios in a system.

GE TYPE 99 FORMAT

Tone frequencies in the GE tone system fall within the range of 517.5 to 997.5 MHz.

NOTE

A round-off error will occur when entering the tone frequencies. This error is less than 0.2% and will not cause any decoding problems. For example, if the standard tone frequency of 517.5 Hz is entered, the actual decoder frequency will be 517.5 Hz. This new frequency will appear on the screen in the tone tables.

In the GE tone format, the first tone may be from tone group A (for Individual or Group calls) or from tone group C (for Super Group calls). The second tone may be from tone group B (for Individual calls) or from tone group D (for Group and Super Group calls). The GE tone format is illustrated below.

GENERAL ELECTRIC FORMAT

INDIVIDUAL CALL FORMAT

<.....1.0 SEC.....>	<.....200 MS.....>	<.....1.0 SEC.....>
±20%	±25%	+300% - 0%
TONE A	GAP	TONE B

GROUP CALL FORMAT

<.....1.0 SEC.....>	<.....200 MS.....>	<.....1.0 SEC.....>
±20%	±25%	+300% - 0%
TONE A	GAP	TONE D

SUPER GROUP CALL FORMAT

<.....1.0 SEC.....>	<.....200 MS.....>	<.....1.0 SEC.....>
±20%	±25%	+300% - 0%
TONE C	GAP	TONE D

For example, assume the paging number to be 123. The first digit of the paging number is a 1. Look in Table 2, and read down the column labeled "100's Digit" to a 1. Read horizontally across to the column labeled "10's

Digit". The tone group is B. The second digit of the paging number is a 2. The tone number is B2. Look in Table 3 and down the column labeled "Tone Designator" to find B2. Read horizontally across to the column labeled "Tone Frequency". The first tone frequency is 787.5 Hz.

To determine the second tone frequency look in Table 2 and as before, find the first digit of the paging number 1.

The second tone group is A. The third digit of the paging number is a 3 and the Tone Designator is A3. In Table 3 read down the column labeled "Tone Designator" and find A3. Read horizontally across the column labeled "Tone Frequency". The second tone frequency is 802.5 Hz.

For different paging numbers, locate the first digit in the "100's Digit" column and determine the tone frequencies as described in the example. For a complete description of tone applications see DATAFILE BULLETIN DF-5000-3A.

Tone D is the diagonal tone used (in GE tone systems only) when the first and second tone frequencies are the same. The standard frequency for Tone D is 742.5 Hz, but may be programmed with any tone frequency.

Table 2 - Tone Groups

100's DIGIT	10's DIGIT	1's DIGIT
	For 1st Tone	For 2nd Tone
0	A	A
1	B	A
2	B	B
3	A	B
4	C	C
5	C	A
6	C	B
7	A	C
8	B	C
9	Not Used	

Table 3 - Tone Generator Frequencies

TONE GROUP	TONE DESIGNATOR	TONE FREQUENCY
A	A0	682.5 Hz
	A1	592.5 Hz
	A2	757.5 Hz
	A3	802.5 Hz
	A4	847.5 Hz
	A5	892.5 Hz
	A6	937.5 Hz
	A7	547.5 Hz
	A8	727.5 Hz
B	B0	652.5 Hz
	B1	607.5 Hz
	B2	787.5 Hz
	B3	823.5 Hz
	B4	877.5 Hz
	B5	922.5 Hz
	B6	967.5 Hz
	B7	517.5 Hz
	B8	562.5 Hz
C	C0	667.5 Hz
	C1	712.5 Hz
	C2	772.5 Hz
	C3	817.5 Hz
	C4	862.5 Hz
	C5	907.5 Hz
	C6	952.5 Hz
	C7	532.5 Hz
	C8	577.5 Hz
Diagonal Tone		742.5 Hz

MOTOROLA FORMAT

Tone frequencies in the Motorola tone systems fall within the range of 288.5 to 1433.4

NOTE

Tone frequencies above 1000 Hz must be rounded off to the nearest Hz when programming the tone tables. For example, the standard tone frequency of 1153.4 Hz must be entered as 1153 Hz. Also, the program will cause a round-off error of ±0.2 Hz for frequencies below 1000 Hz. These errors will not cause any decoding problems.

In the Motorola tone format, the first tone may be one of three tones: A for Individual Call, B for Quick Call, and C for Group Call. The second or final tone is B in all cases.

NOTE

The MVS radio is able to recognize the A, B, and C tones. Individual, Group and Quick Call formats may be used simultaneously.

The Motorola tone format is illustrated below.

INDIVIDUAL CALL FORMAT

<..1.0 sec. min..>	<.....NONE.....>	<...3 sec. min...>
TONE A	GAP	TONE B

GROUP CALL FORMAT

<..1.0 sec. min..>	<.....NONE.....>	<...3 sec. min...>
TONE C	GAP	TONE B

QUICK CALL FORMAT

<.....8 sec.....>
TONE B

INDIVIDUAL CALL

Tables 4 and 5 may also be used to determine the tone frequencies.

The first digit of the code determines the tone groups used in the code (See Table 4). Then Table 5 is used to determine the actual tone frequencies.

For a code of 124, the tone groups used are shown in Table 4. (Tone A and Tone B are both located in Tone Group 1, and Tone B is tone number 4. Refer to the following examples for additional information.

EXAMPLE 1 - Code 098:

The digit "0" in Table 4 (First Digit of Code) shows that Tone A is in Tone Group 4, and Tone B is in Tone Group 2 (See Table 5).

Tone number 9 in Tone Group 4 is 524.6 Hz.
Tone number 8 in Tone Group 2 is 879.0 Hz.

EXAMPLE 2 - Code 265:

The digit "2" in Table 4 shows that both Tone A and Tone B are both in Tone Group 2.

Tone number 6 is 788.5 Hz.
Tone number 5 is 746.8 Hz.

TABLE 4 - MOTOROLA-TYPE CODER NUMBERS

First Digit Of Code	Group From Which Tone A Is Selected	Group From Which Tone B Is Selected
1	1	1
2	2	2
3	1	2
4	4	4
5	5	5
6	2	1
7	4	5
8	5	4
9	2	4
0	4	2
A	3	3

GROUP CALL (Quick-Call Format)

In Group Call application, the Tone Group is determined by Table 6, while the frequency is determined by Table 5. Refer to the following examples.

NOTE

Group Call code numbers range from 00 to 99. However, there are several Group Calls with the same Tone B frequency. This limits the total number of Group Calls to 40.

Table 5 - Motorola Tone Frequencies And Groups

Tone No.	Tone Group 1	Tone Group 2	Tone Group 3	Tone Group 4	Tone Group 5	Tone Group 6
1	349.0 Hz	600.9 Hz	288.5 Hz	339.6 Hz	584.8 Hz	1153.4 Hz
2	368.5 Hz	634.5 Hz	296.5 Hz	358.6 Hz	617.4 Hz	1185.2 Hz
3	389.0 Hz	669.9 Hz	304.7 Hz	378.6 Hz	651.9 Hz	1217.8 Hz
4	410.8 Hz	707.3 Hz	313.0 Hz	399.8 Hz	688.3 Hz	1251.4 Hz
5	433.7 Hz	746.8 Hz	322.1 Hz	422.1 Hz	726.8 Hz	1285.8 Hz
6	457.9 Hz	788.5 Hz	331.2 Hz	445.7 Hz	767.4 Hz	1321.2 Hz
7	483.5 Hz	832.5 Hz	340.3 Hz	470.5 Hz	810.2 Hz	1357.6 Hz
8	510.5 Hz	879.0 Hz	349.4 Hz	496.8 Hz	855.5 Hz	1395.0 Hz
9	539.0 Hz	928.1 Hz	358.5 Hz	524.6 Hz	903.2 Hz	1433.4 Hz
0	330.5 Hz	569.1 Hz	367.6 Hz	321.7 Hz	553.9 Hz	1122.5 Hz

EXAMPLE 1 - Group Call Code 07 (also code 27 and 37):

The digit "0" in Table 6 shows that Tone B is in Tone Group 2 along with 20 to 29 and 30 to 39. Tone number 7 in Tone Group 2 is 832.5 Hz (See Table 5).

EXAMPLE 2 - Group Call Code 98 (also code 48 and 88):

The digit "9" in Table shows that Tone B is in Tone Group 4 along with 40 to 49 and 80 to 89. Tone number 8 in Tone Group 4 is 496.8 Hz.

Table 6 - Motorola Group Call Tone Groups (TG)

00-09	TG2
10-19	TG1
20-29	TG2
30-39	TG2
40-49	TG4
50-59	TG5
60-69	TG1
70-79	TG5
80-89	TG4
90-99	TG4

NOTE

When using the PC (personal computer) programming software to program MVS radios with Remote Mount Option 19A705306G3 caution should be taken to make the correct connections. The programming cable TQ3315 (part of programmer equipment) must be connected to the microphone jack J725 on the **remote control unit**. If the cable is connected to the microphone jack on the main radio unit, the radio cannot be programmed correctly. Refer to TQ-3318 (5 1/4" disks) or TQ-4318 (3 1/2" disks) for programming instructions.

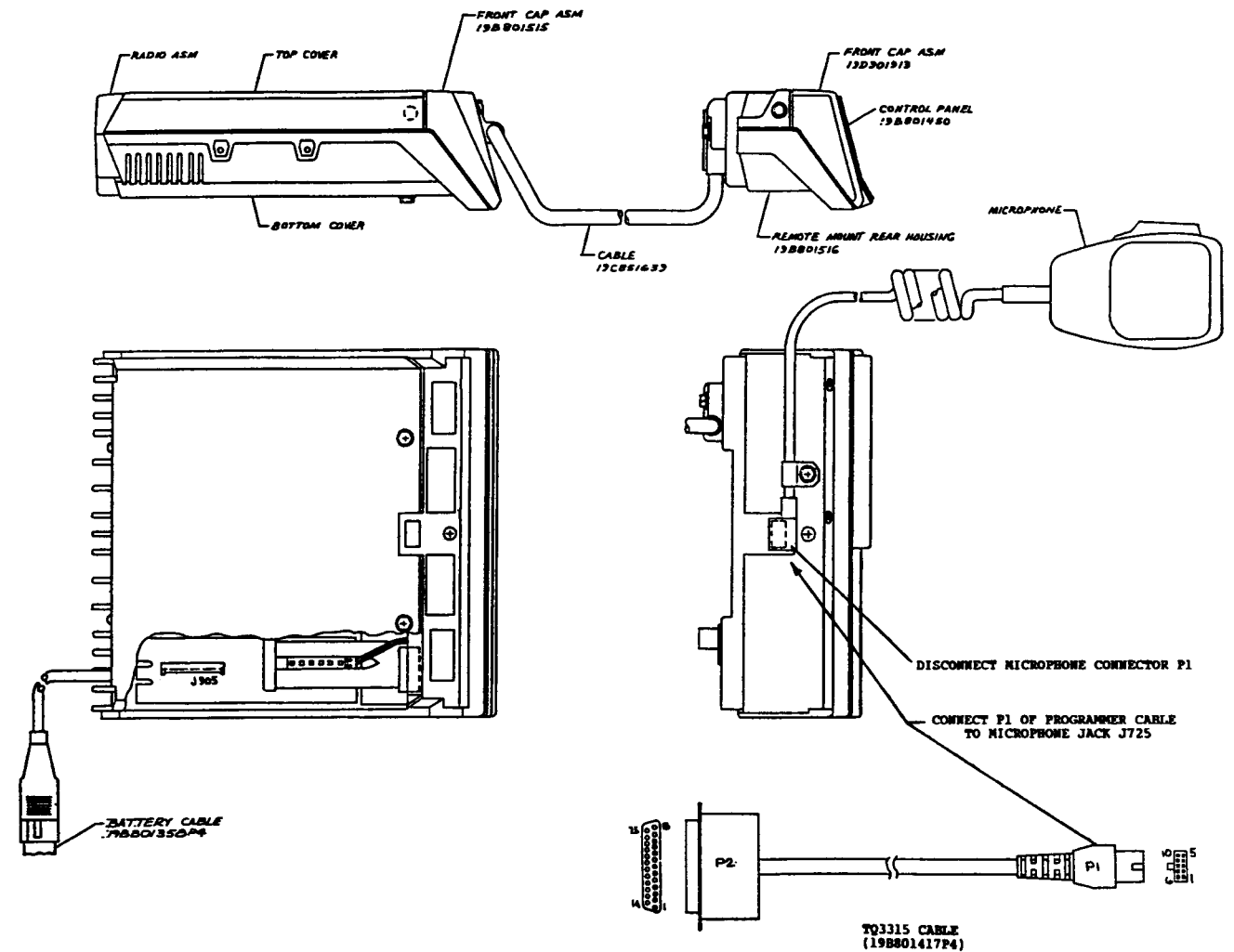

ERICSSON  
Ericsson GE Mobile Communications Inc.
Mountain View Road • Lynchburg, Virginia 24502

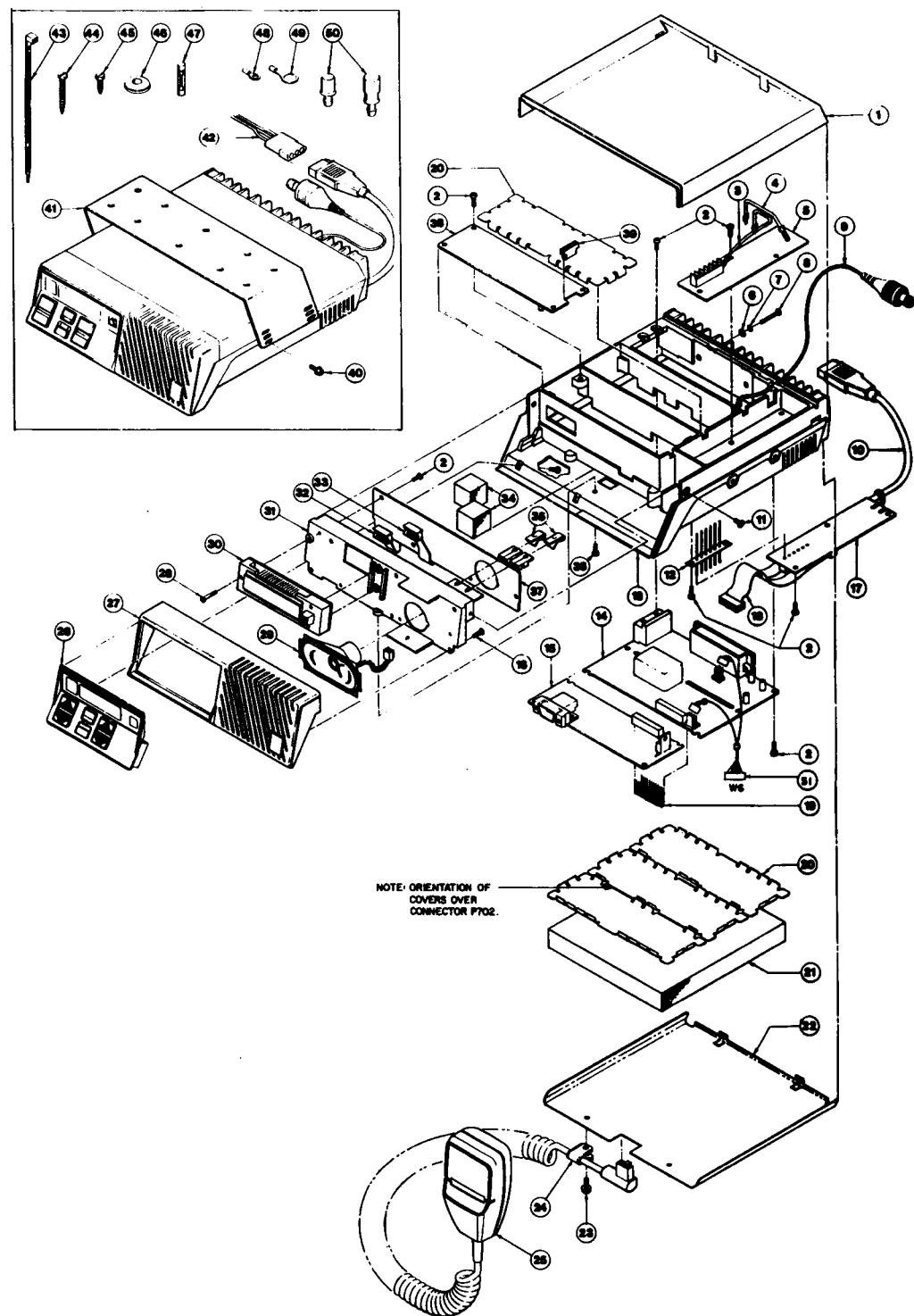

PARTS LIST

MVS MECHANICAL PARTS
ISSUE 2

SYMBOL	GE PART NO.	DESCRIPTION
1	19A705216G1	Top Cover.
2	19A702381P508	Screw: M3.5 - 0.6 x 8. (Quantity 27).
3	19A704884P4	RF Cable Assembly. (W8).
4	19A704884P3	RF Cabl. Assembly. (W7).
5		PA Board (A4).
6	19A700033P6	Lockwasher: M3.5. (Quantity 2).
7	19A701312P5	Flatwasher: M3.5. (Quantity 2).
8	19A702381P520	Screw: M3.5 - 0.6 x 20. (Quantity 2).
9	19A705301P1	RF Cable Assembly. (W1).
10		Power Cable (W901). (Part of System Board A5).
11	19A702362P908	Screw: M3.5 - 0.6 - 8. (Quantity 2).
12	19A705126P1	Feed-through Capacitor Assembly (1903).
13	19D901881G1	Casting.
14		RF Board (A2).
15		Logic Board (A1).
16	19A705381P13008	Screw, thread forming: #6(.138) x 1/2. (Quantity 4).
17		System Board (A5).
18	19A705235P1	Cable Assembly (W3).
19	19B801359P3	Connector (P702).
20	19C851442P1	Cover. (Quantity 4).
21	19A705421P1	Dust Pad.
22	19C851573G1	Bottom Cover.
23	19A705406P408	Screw: M4 - 0.7 x 8. (Quantity 2).
24	19A701863P17	Cable Clamp.
25	19B801398P4	Microphone.
26	19B801450	Control Panel (A8).
27	19D901890P1	Front Cap.
28	19A702364P316	Screw: M3 - 0.5 x 16. (Quantity 3).
29	19A705165P1	Loudspeaker (B901).
30	19B801459P1	LCD Assembly (A7).
31	19D901889G1	Shield Can.
32	19A705234P1	Cable Assembly (W5).
33	19A705234P1	Cable Assembly (W4).
34	19A705421P2	Foam Pad. (Quantity 2).
35	19A705244P2	Clip, Spring Tension. (Quantity 2).
36	19A702364P408	Screw: M3.5 - 0.6 x 8.
37		Control Board (A6).
38		Audio Board (A3).
39	19A705282P1	Clip.
51	19B801467P1	Cable Assembly (W6).
NOTE: THE FOLLOWING ITEMS ARE PART OF HARDWARE KIT 19A138051G11		
40	19A705406P408	Screw: M4 - 0.7 x 8. (Quantity 4).
41	19C851586G1	Mounting Bracket.
43	19J706152P9	Cable Tie. (Quantity 1).
44	M130P1624B6	Screw: #10 x 1 1/2. (Quantity 6).
45	M130P1610B6	Screw: #10 x 5/8. (Quantity 6).
46	5490407P6	Rubber Grommet. (Quantity 1).

*COMPONENTS ADDED, DELETED OR CHANGED BY PRODUCTION CHANGES

SYMBOL	GE PART NO.	DESCRIPTION
NOTE: THE FOLLOWING ITEMS ARE SUPPLIED WITH THE BATTERY CABLE.		
42	19B801358P2	Battery Cable.
47	1R16P5	Fuse: 2 amp, sim to Bussman AGC2. (Quantity 1).
	7102673P2	Fuse: 15 amp, sim to Bussman AGC15. (Quantity 1).
48		Terminal: sim to Amp 34112. (Quantity 2).
49		Terminal: sim to Amp 34126. (Quantity 2).
50	19A149451P2	Fuse holder: sim to Bussman HBB. (Quantity 2).

INTERCONNECTION DIAGRAM

LBI-31919

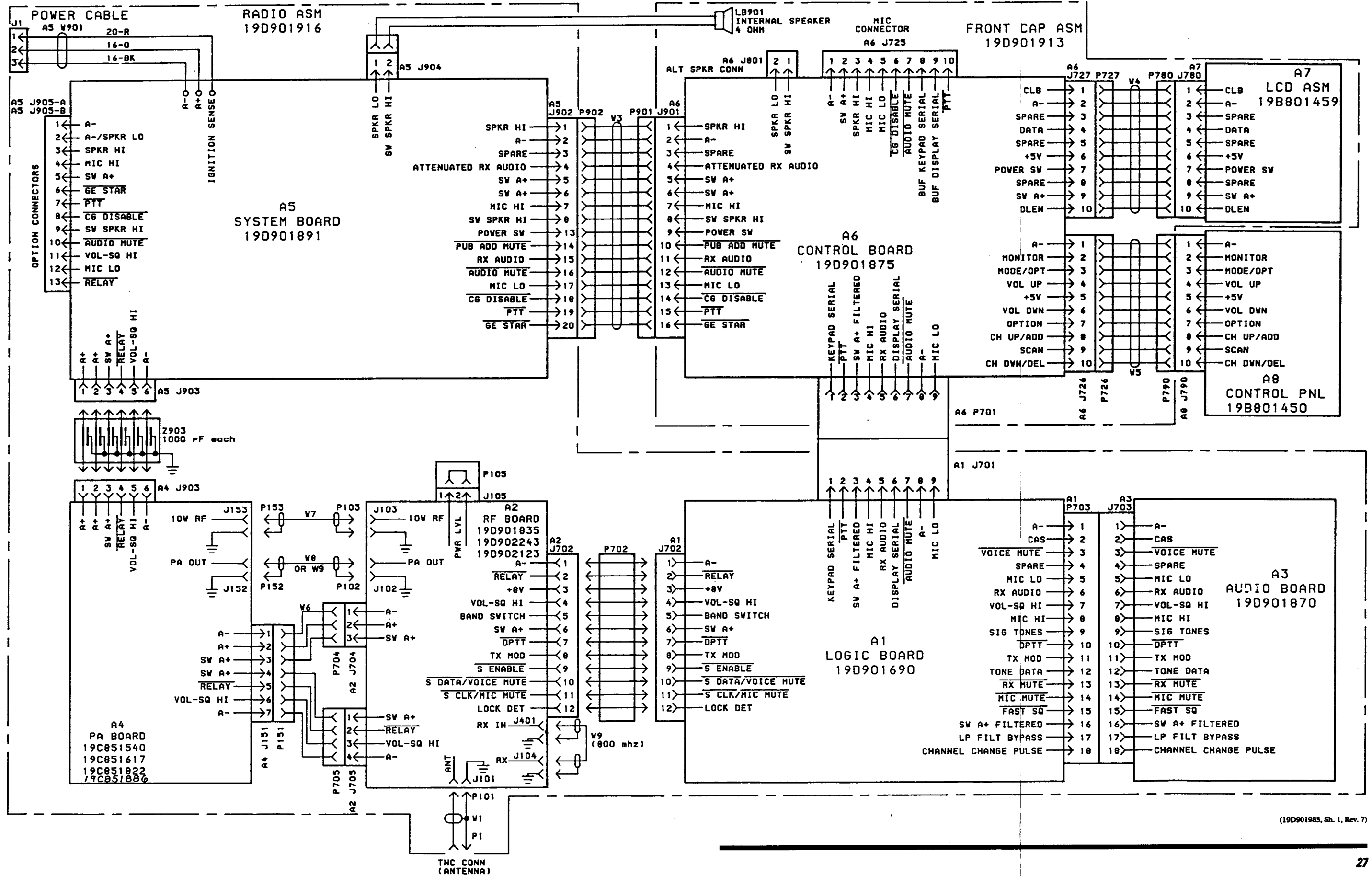

(19D901985, Sh. 1, Rev. 7)

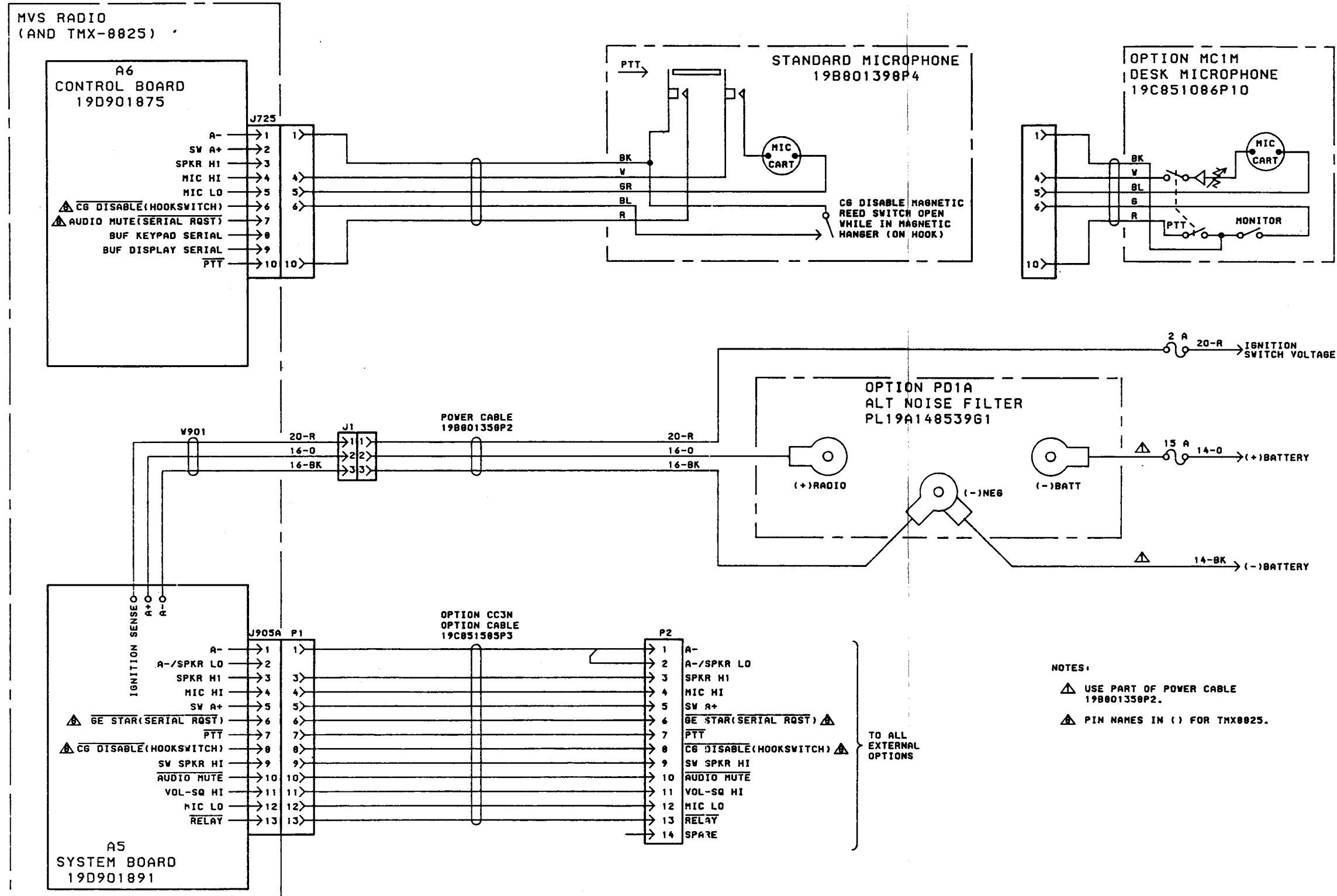

- NOTES:
- △ USE PART OF POWER CABLE 19B801358P2.
 - △ PIN NAMES IN () FOR TMX8825.

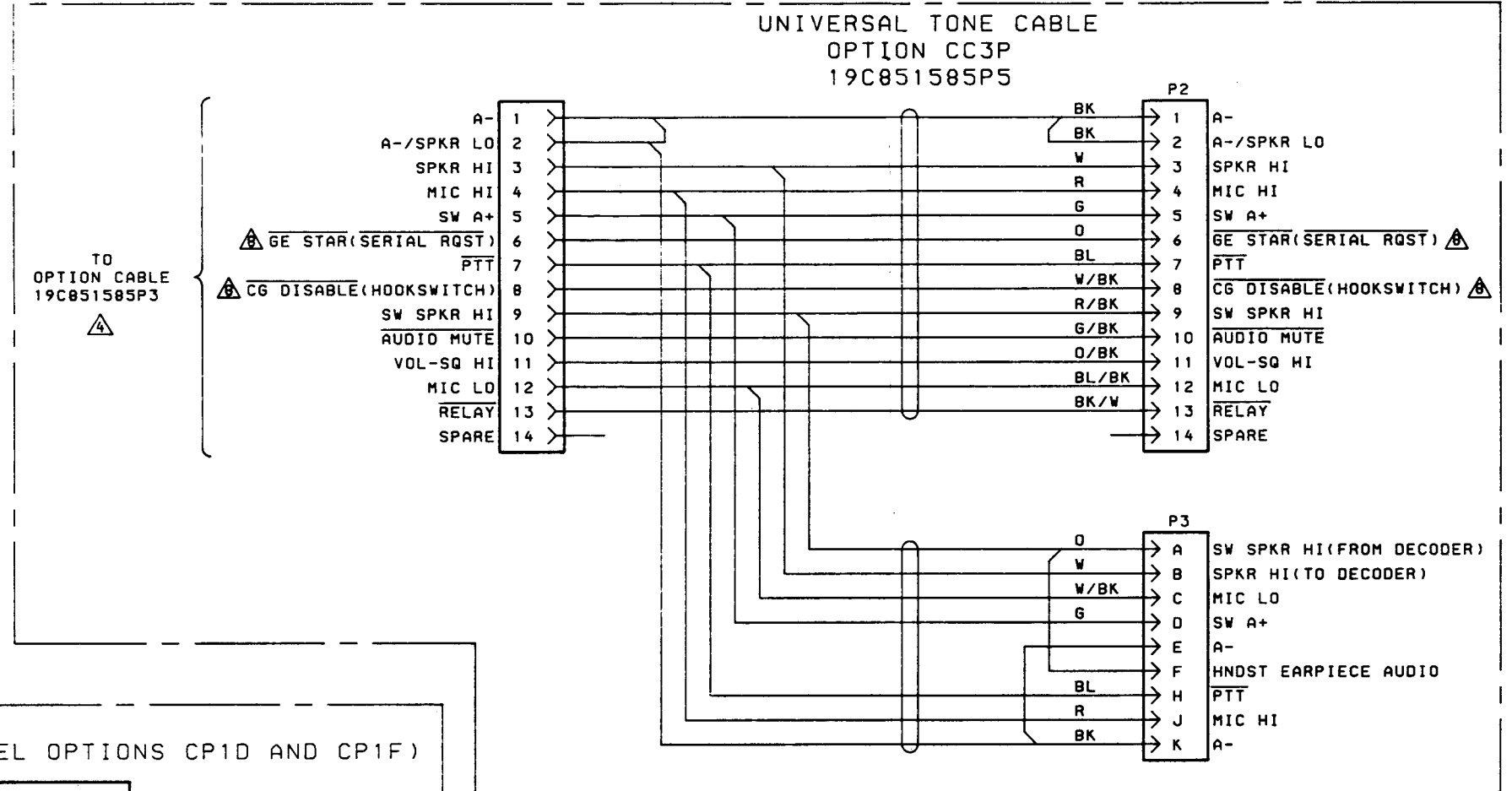
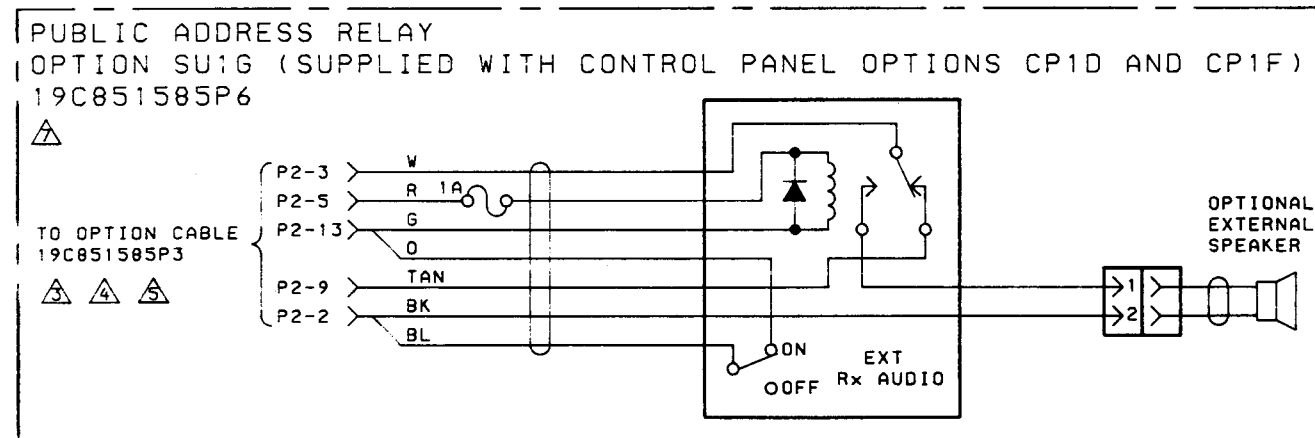
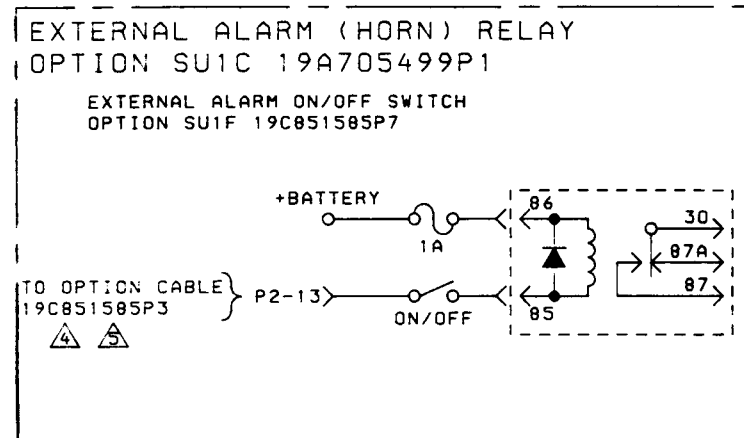
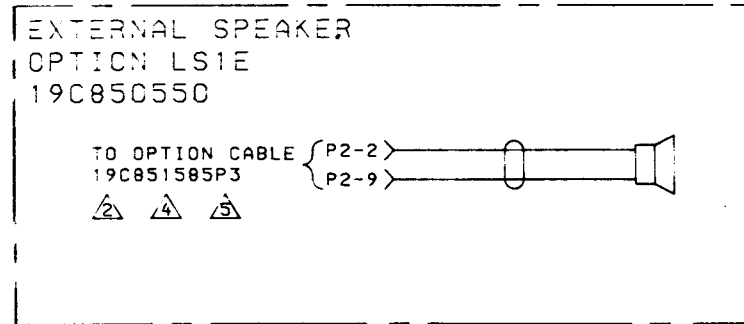

NOTES:

- 2 UNPLUG INTERNAL SPEAKER FROM A5 J904 ON SYSTEM BOARD 19D901891. FOR REMOTE MOUNT APPLICATION, UNPLUG SPEAKER FROM A6 J801 ON CONTROL BOARD 19D901875.
- 3 TO ALLOW SWITCHING OF THE INTERNAL SPEAKER, CUT PC RUN BETWEEN HOLES 6 AND 7 ON A5 SYSTEM BOARD 19D901916. FOR REMOTE MOUNT APPLICATION, CUT RUN BETWEEN HOLES 7 AND 8 ON A10 FRONT CAP INTERFACE BOARD 19D902025.
- 4 FOR REMOTE MOUNT APPLICATION, CONNECT TO THE SAME PINS OF A10 J1102 OPTION CONNECTOR.
- 5 WHEN USING THE UNIVERSAL TONE CABLE, CONNECT TO P2 OF THE UNIVERSAL TONE CABLE OPTION 19C851585P5.
- 7 NOT AVAILABLE FOR TMX8825.
- 8 PIN NAMES IN () FOR TMX8825.

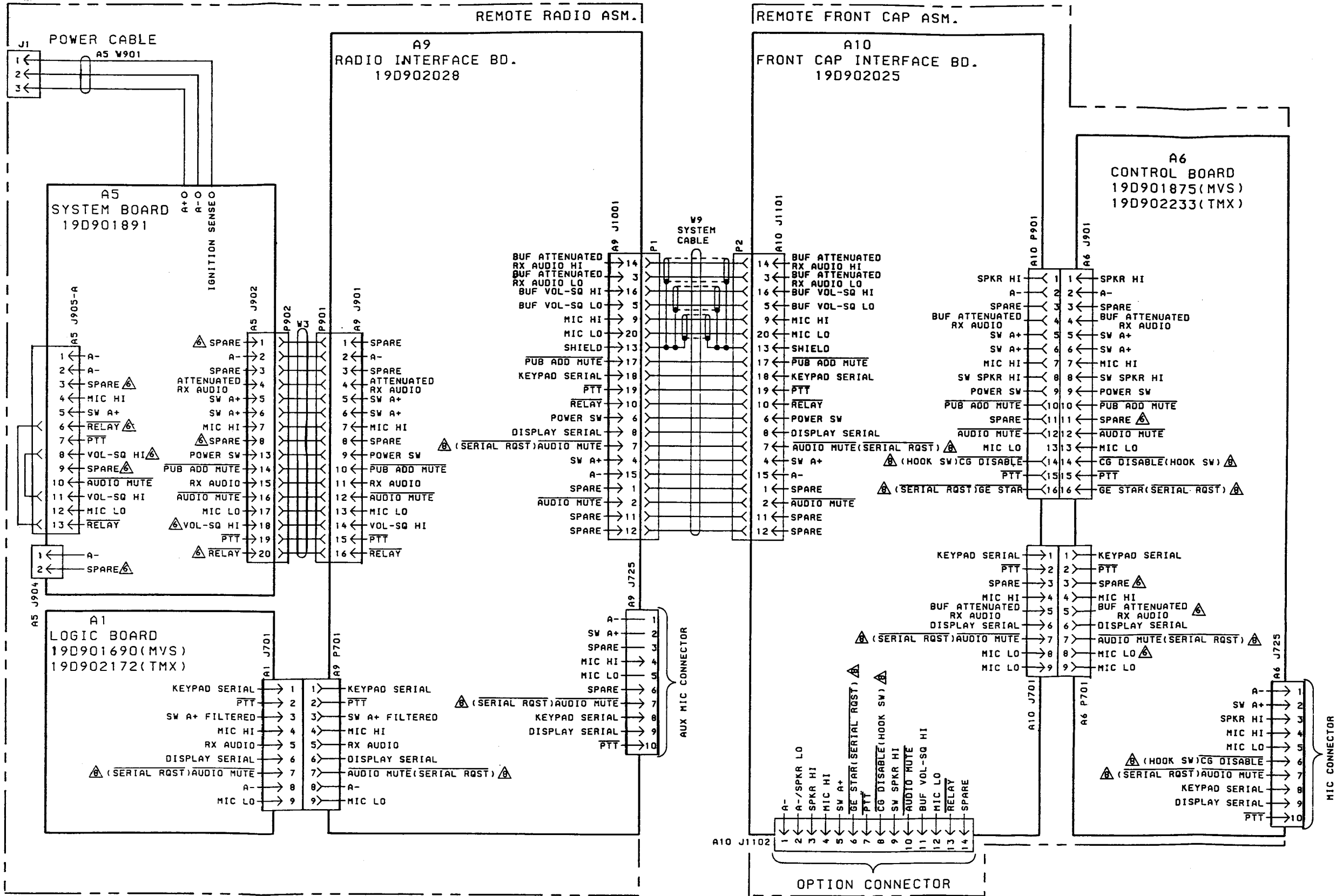

(19D901985, Sh. 4, Rev. 2)

NOTES:

△ NEW PIN NAMES FOR REMOTE MOUNT.

⊠ PIN NAMES IN () FOR TMX-8825.