

FURUNO

INSTALLATION MANUAL

SSB RADIOTELEPHONE

FS-1562-15(150W)

MODEL FS-1562-25(250W)

After installation, if necessary, enter user channels and adjust output power referring to separate Service Manual.



FURUNO ELECTRIC CO., LTD.
NISHINOMIYA, JAPAN

© **FURUNO ELECTRIC CO., LTD.**

9-52, Ashihara-cho,
Nishinomiya, Japan

Telephone: 0798-65-2111
Telefax: 0798-65-4200

•Your Local Agent/Dealer

All rights reserved.

Printed in Japan

FIRST EDITION : NOV. 1993
K : AUG. 6, 2001

(TENI)

PUB. No. IME-55722-K
FS-1562-15/25



* 00080552900 *



SAFETY INSTRUCTIONS

"**DANGER**", "**WARNING**" and "**CAUTION**" notices appear throughout this manual. It is the responsibility of the installer of the equipment to read, understand and follow these notices. If you have any questions regarding these safety instructions, please contact a FURUNO agent or dealer.



DANGER

This notice indicates a potentially hazardous situation which, if not avoided, will result in death or serious injury.



WARNING

This notice indicates a potentially hazardous situation which, if not avoided, could result in death or serious injury.



CAUTION

This notice indicates a potentially hazardous situation which, if not avoided, could result in minor or moderate injury, or property damage.

SAFETY INFORMATION FOR THE INSTALLER



WARNING



Only qualified personnel should work inside the equipment.

This equipment uses high voltage electricity which can shock, burn, or cause death.

Turn off the power at the ship's mains switchboard before beginning the installation. Post a warning sign near the switchboard to ensure that the power will not be applied while the equipment is being installed.

Serious injury or death can result if the power is not turned off, or is applied while the equipment is being installed.



CAUTION



Ground the equipment.

Ungrounded equipment can give off or receive electromagnetic interference or cause electrical shock.

Confirm that the power supply voltage is compatible with the voltage rating of the equipment.

Connection to the wrong power supply can cause fire or equipment damage. The voltage rating appears on the label at the rear of the equipment.

Table of Contents

Specification.....	ii
--------------------	----

Chapter 1 Installation

1.1 Transceiver	1-1
1.2 Antenna Coupler	1-3
1.3 Fan Kit and Piggy-mount Hanger	1-7
1.4 Ground System	1-8
1.5 The Antenna	1-9
1.6 Power Amp Unit (PA-2500, 250W only)	1-10
1.7 Power Supply Units (option)	1-10

Chapter 2 Connections

2.1 Connection of Units	2-1
2.2 Power Cable	2-1
2.3 AC-DC Power Supply Unit (PR-300 for 150W set)	2-1
2.4 Power Supply Unit (PR-850/PR-850A for 250W set)	2-2
2.5 Installation of the AC FAIL Board (option)	2-7

Chapter 3 Connection of External Equipment

3.1 NBDP Terminal DP-6	3-1
3.2 DSC Terminal DSC-60	3-1
3.3 Remote Station RB-500	3-1
3.4 Distributors (DB-120/DB-500)	3-1
3.5 BK (Break-in) Connection	3-2

Chapter 4 Installation Checks

4.1 Introduction	4-1
4.2 Visual Check	4-1
4.3 Self-test	4-1
4.4 Performance Check	4-1
4.5 User Channel	4-2
4.6 Manual 2182 kHz Tuning Preset	4-2

Outline Drawings and Schematic Diagrams

Outline Drawings	D-1
Schematic Diagrams	S-1

Specifications

GENERAL

Communication System	Simplex or semi-duplex
Frequency Range	1.6 to 27.5 MHz (transmit) 0.1 to 30 MHz (receive)
Frequency Resolution	Transmit: 100 Hz Receive: 10 Hz
Class of Emission	J3E (LSB) J3E (USB) H3E (AM compatible) F1B, J2B (for DSC, NBDP terminal) J3C (weather facsimile, reception only)
Frequency Stability	± 10 Hz
Number Of Channels	User Channel: 200 ITU SSB/Telex Channel 2182 kHz (single action)
Ambient Temperature Range	-20°C to +55°C
Relative Humidity	93% at 40°C
Power Supply & Power Consumption	24VDC + 30 -10% Receive: 2A Transmit(max.): FS-1562-15 ...20 A FS-1562-25 ...40 A
Frequency Selection	Key or dial encoder
Dimmer	Illumination for Keyboard and LCD (four levels incl. off)
Dimensions and Mass	Transceiver 105 mm(W) x 256 mm(H) x 300 mm(D), 6.4kg Power Amp 290mm(W) x 146mm(H) x 294mm(D), 6.0kg

RECEIVER

Receiving System	Double-conversion superheterodyne IF: 54.455 MHz and 455 kHz																				
Sensitivity	Input level to produce SINAD 20 dB <table> <thead> <tr> <th></th> <th>J3E</th> <th>H3E</th> <th>F1B</th> </tr> </thead> <tbody> <tr> <td>0.1 to 0.3 MHz (*1)</td> <td>+40</td> <td>+54</td> <td></td> </tr> <tr> <td>0.3 to 1.6 MHz (*1)</td> <td>+25</td> <td>+39</td> <td></td> </tr> <tr> <td>1.6 to 4 MHz (*1)</td> <td>+16</td> <td>+30</td> <td>6</td> </tr> <tr> <td>4 to 30 MHz (*2)</td> <td>+3</td> <td></td> <td>-7</td> </tr> </tbody> </table> (*1): at 10 ohms + 250pF (*2): at 50 ohms (dB μ V)		J3E	H3E	F1B	0.1 to 0.3 MHz (*1)	+40	+54		0.3 to 1.6 MHz (*1)	+25	+39		1.6 to 4 MHz (*1)	+16	+30	6	4 to 30 MHz (*2)	+3		-7
	J3E	H3E	F1B																		
0.1 to 0.3 MHz (*1)	+40	+54																			
0.3 to 1.6 MHz (*1)	+25	+39																			
1.6 to 4 MHz (*1)	+16	+30	6																		
4 to 30 MHz (*2)	+3		-7																		
Selectivity	2.4 kHz at -6 dB (J3E) 6.0 kHz at -6 dB (H3E) 300 Hz at -6 dB (F1B)																				
Spurious Response	Better than 70 dB																				
Intermodulation	Better than 80 dB																				
Audio Output	Internal speaker: 1 W/ 8 ohm External speaker: 5 W/ 4 ohm Line output: 0 dBm / 600 ohm																				
Other Features	RF Gain: Adjustable Squelch: ON/OFF, Activated by voice/signal strength Dimmer: OFF/Low/Medium/High Speaker: ON/OFF (Handset always alive) AGC: ON/OFF Noise blanker: always ON																				
<u>TRANSMITTER</u>																					
Output Impedance	50 ohms																				
Output Power	J3E/H3E: FS-1562-15...150W _{pep} FS-1562-25...250W _{pep} F1B: FS-1562-15...150W FS-1562-25...250W Tune: 10 to 20 W approx.																				
Power Reduction	60W																				
Controls	Output HI/LOW, test/send of two-tone alarm generator, 2182kHz single action key																				

ANTENNA COUPLER

Tuning System	CPU controlled fully automatic tuning system
Frequency Range	1.6 to 27.5 MHz
Input Impedance	50 ohms (viewed from transceiver)
Antenna Required	7 to 30 m wire or whip
Power Capability	FS-1562-15...150W FS-1562-25...250W
Tuning Power	10 to 20 W
VSWR	Less than 1.5
Tuning Time	Within 2 to 15 seconds Within 0.5 second on pretuned bands
Dummy Load	Mounted in the COUPLER (10 ohms + 250pF)
Power Requirement	15VDC 0.6A (supplied from transceiver)
Ambient Temperature	-30°C to + 70°C at 93% relative humidity
Construction	Waterproof plastic cabinet, stainless steel mount
Dimensions and Mass	297 mm (W) x 390 mm (H) x 90 mm (D), 3.1 kg approx.

POWER AMP UNIT(PA-2500, only for FS-1562-25)

Input Power	60W
Output Power	250W
Input/Output Impedance	50 ohms
Ambient Temperature	- 20 to + 55 °C
Power Supply	24VDC, 30A

EQUIPMENT LIST

Complete Set

No.	Name	Type	Code No.	Qty	Remarks
1	Transceiver Unit	FS-1562-15	000-055-239	1	For 150W
		FS-1562-25	000-057-206		For 250W
2	Antenna Coupler	AT-1560-15-AAS	000-055-245	1	For 150W, Resin
		AT-1560-15-SUS	000-055-263		For 250W, Stainless steel
		AT-1560-25-AAS	000-055-255		For 150W, Resin
		AT-1560-25-SUS	000-055-265		For 250W, Stainless steel
3	Power Amp Unit	PA-2500	000-057-201	1	For 250W
4	Accessories	FP05-02010	000-055-201	1 set	For handset
		FP05-02010	000-055-200		For microphone (option)
		FP05-02020	000-055-202		For noise-canceling microphone (option)
5	Spare Parts	SP05-03700	000-055-240	1 set	For transceiver unit
		SP05-04100	000-057-203	1 set	For PA-2500
6	Installation Materials	CP05-05600	000-054-241	1 set	For trans. unit
		CP05-05700	000-055-238	1 set	For ant. coupler
		CP05-06700	000-057-204	1 set	For PA-2500
7	Cable Assembly				Control/Coax-cable
8	BK relay kit				For FS-1562-25

Complete Set

No.	Name	Type	Code No.	Qty	Remarks
1	Power Supply	PR-300	000-130-431	1	For 150W
		PR-850	000-129-040		For 250W
		PR-850A			
2	Fan Kit	OP05-54	005-944-630	1 set	
3	Piggy-mount Hanger	OP05-95	005-950-660	1	
4	Piggy-mount Hanger w/Fan Kit	OP05-69	005-955-650	1 set	
5	Doublet Antenna	E-22	000-050-632	1 set	
6	Single Wire Antenna	E-24	000-050-634	1 set	
7	Double-span Antenna	E-25	000-050-635	1 set	
8	Whip Antenna Lead-in	E-26	000-050-636	1 set	
9	Whip Antenna Feeder	E-27	000-050-637	1 set	
10	Whip Antenna	FAW-6D	000-572-128	1 set	
		FAW-6R2	000-572-108		
		FAW-6R2A	000-107-921		
11	BK Interface	BK-300	000-055-478	1 set	
14	AC FAIL Board	05P0657	005-945-870	1 set	
15	Coupler Installation Materials	OP05-12	005-923-680	1 set	U-bolts for fixing antenna coupler
16	External Speaker	SEM-21Q	000-144-917	1	
17	REMOTE-B Kit	OP05-40	005-920-320		Current loop, for RB-500/DB-500
18	BK Relay Kit				Refer to page 3-2 for FS-1562-15.

Accessories for transceiver unit (FP05-02010; handset type)

No.	Name	Type	Code No.	Qty	Remarks
1	Hanger	FP05-02001	005-922-690	1	
2	Tapping Screw	6x20 SUS304	000-800-414	6	
3	Knob Bolt	KG-B2 M8x20 SUS304	000-800-601	2	
4	Flat Washer	M6 SUS304	000-864-129	6	
5	Hanger Washer	05-029-0132	100-087-911	2	
6	Knob Washer	05-029-0135	100-100-390	2	
7	Handset Hanger	05-024-1001	100-095-691	2	
8	Stopper	05-024-1002	100-095-701	1	
9	Template	05-024-1003	100-095-711	1	
10	Tapping Screw	3x20 SUS304	000-801-662	6	
11	Handset	HS-6000FZ5	000-112-623	1	

Accessories for transceiver unit (FP05-02000; hand-microphone type option)

No.	Name	Type	Code No.	Qty	Remarks
1	Hanger	FP05-02001	005-922-690	1	
2	Tapping Screw	6x20 SUS304	000-800-414	6	
3	Knob Bolt	KG-B2 M8x20 SUS304	000-800-601	2	
4	Flat Washer	M6 SUS304	000-864-129	6	
5	Hanger Washer	05-029-0132	100-087-911	2	
6	Knob Washer	05-029-0135	100-100-390	2	
7	Microphone	DM1620FZI	000-112-622	1	

Accessories for transceiver unit (FP05-02020; noise-canceling mic. type, option)

No.	Name	Type	Code No.	Qty	Remarks
1	Hanger	FP05-02001	005-922-690	1	
2	Tapping Screw	6x20 SUS304	000-800-414	6	

3	Knob Bolt	KG-B2 M8 x 20 SUS 304	000-800-601	2	
4	Flat Washer	M6 SUS304	000-864-129	6	
5	Hanger Washer	05-029-0132	100-087-911	2	
6	Knob Washer	05-029-0135	100-100-390	2	
7	Noise-canceling Microphone	M112D4509910	000-116-487	1	

Installation Materials for transceiver unit (CP05-05600)

No.	Name	Type	Code No.	Qty	Remarks
1	Power Cable	05S0932	000-130-430	1	with 20A fuse, 2m
2	Ground Wire	05S0479	000-113-348	1	2m

Installation Materials for antenna coupler (CP05-05700)

No.	Name	Type	Code No.	Qty	Remarks
1	Tapping Screw	5 x 16 SUS304	000-805-494	4	
2	Pipe Seal	05S0938	000-130-472	1	
3	Copper Strap	04S0801	000-572-187	1	30 x 1200 x 0.3mm
4	Blind Plug	05-039-6325CR	100-164-380	1	

Installation Materials for antenna coupler (cable assembly)

No.	Name	Type	Code No.	Qty	Remarks
1	Control Cable Assy.	05S0949, 10m	000-130-484	1	10m cable supplied, if cable length is not specified.
		05S0949, 20m	000-130-485		
		05S0949, 30m	000-130-486		
		05S0949, 40m	000-130-487		
		05S0949, 50m	000-130-488		
2	Coax. Cable Assy.	05S0462, 10m	000-113-360	1	10m cable supplied, if cable length is not specified.
		05S0462, 20m	000-113-361		
		05S0462, 30m	000-113-362		
		05S0462, 40m	000-113-363		
		05S0462, 50m	000-113-364		

Installation Materials for power amp unit (PA-2500, CP05-06700)

No.	Name	Type	Code No.	Qty	Remarks
1	Power Cable	05S0414-1	000-113-347	1	
2	Ground Wire	05S0479-0	000-113-348	1	2m

Specifications

3	Control Cable Assy.	05S9082-0, 2m	000-134-198	1	Select one. (Between PA-2500 and transceiver)
		05S9082-0, 5m	000-135-121		
		05S9082-0, 10m	000-135-123		
4	Coax. Cable Assy.	05S9081-0, 2m	000-134-199	1	Select one. (Between PA-2500 and transceiver)
		05S9081-0, 5m	000-135-117		
		05S9081-0, 10m	000-135-119		

Spare Parts for transceiver unit (SP05-03700)

No.	Name	Type	Code No.	Qty	Remarks
1	Fuse	FGBO 20A 125 VAC	000-549-015	2	

Spare Parts for Power Amp unit (SP05-04100)

No.	Name	Type	Code No.	Qty	Remarks
1	Fuse	FGBO 30A 125 VAC	000-549-017	2	

Chapter 1 Installation

1.1 Transceiver

Mounting methods

The transceiver can be mounted one of four ways:

- in the hanger (overhead, bulkhead or tabletop) or
- flush mounting.

Mounting considerations

When selecting a mounting location;

- Make sure the location is strong enough to support the unit under the conditions of continued vibration and shock normally encountered on the boat. Where necessary, reinforce the mounting location by lining block or doubling plate.
- Locate the unit where it is easily accessible and does not interfere with personnel or operation of other equipment; for example, ship's wheel.
- Select a location where temperature and humidity are moderate and stable. For added ventilation, install the Fan Kit. See page 1-7.

■ **NOTE:** *The piggy-mount hanger (option) permits piggyback mounting the transceiver together with the FURUNO DSC-60 DSC terminal. See page 1-7.*

Hanger mounting To mount the transceiver by using the hanger;

1. Using the hanger as a template, mark mounting hole locations.
2. Fix the hanger with tapping screws (supplied). (For extra support, drill six pilot holes and use M5 bolts, nuts and washers instead of the tapping screws.)
3. Set the transceiver to the hanger and fix it with the washers and knobs.

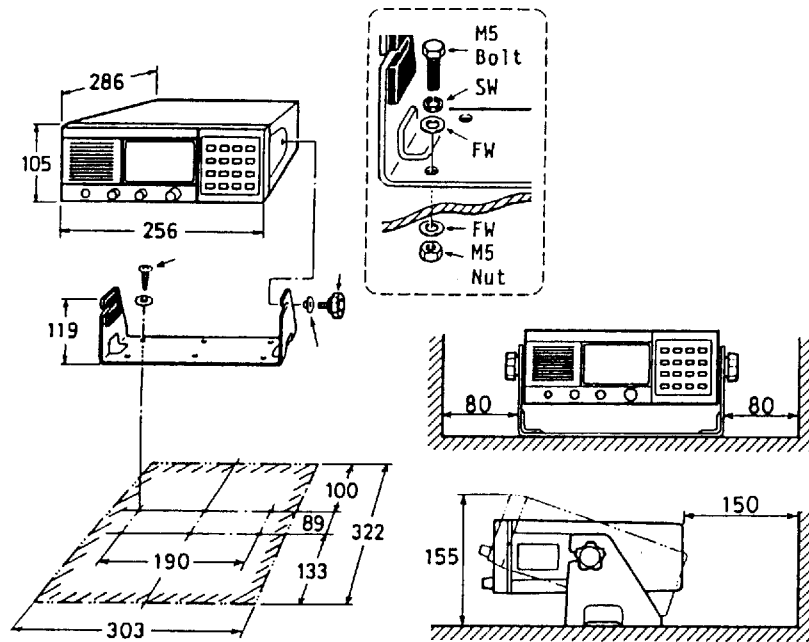

Figure 1-1 Installing the transceiver Figure 1-2 Service clearance

Flush mounting

When selecting a mounting location;

- The mounting location should be strong enough to support the weight of the unit. If necessary, fix the unit to a suitable doubling plate.
- Select a place where the LCD can be easily viewed, keeping in mind that the LCD viewing angle is as shown in Figure 1-3.
- Leave sufficient space around the unit to permit dispersal of heat after long transmission.

Mounting

This method does not require any additional kit. However, the mounting dimensions must be accurate since the hanger also is installed.

Prepare a cutout in the mounting location as shown in Figure 1-3.

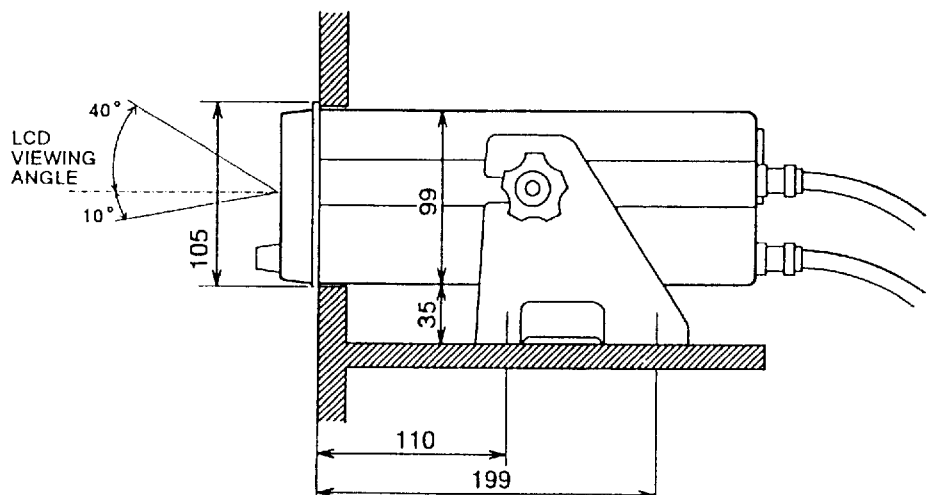

Figure 1-3 Mounting dimensions for flush mount

1.2 Antenna Coupler

Introduction

The antenna coupler is installed between the antenna and the transceiver (or power amp unit for 250W set), and tunes the antenna to the transmitter.

The importance of a good ground system cannot be over-emphasized. Without a good ground, this unit will not work properly – if at all.

Mounting considerations

The splashproof construction of the antenna coupler permits installation either indoors or outdoors. When selecting a location, keep in mind the following points.

Outdoor installation

- The antenna coupler is splashproof, however it is not designed to take a continual soaking. If necessary, seal any opening in the top or sides with silicone sealant.
- Select a location not exposed to salt water spray. Salt water on the antenna insulator may cause unstable operation of the coupler and in the worst case prevent transmission.
- All wires from the coupler to the antenna radiate radio energy. They should be routed away from any grounded conductors such as lifelines, mast shrouds, or fittings.
- For optimum radio energy, locate the coupler as near to the ground as possible.
- The length of the vertical portion of the antenna should be as long as possible.
- Leave enough space around the sides of the unit to permit maintenance and checking.
- Total antenna length should be 7 to 30 meters.

Indoor installation

- Locate the unit away from GPS and Satnav receivers and radio equipment to avoid mutual interference.
- The lead-in wire should be as near to the unit as possible.
- Select a place where the unit can be easily maintained, but where it will not interfere with crew or passengers.

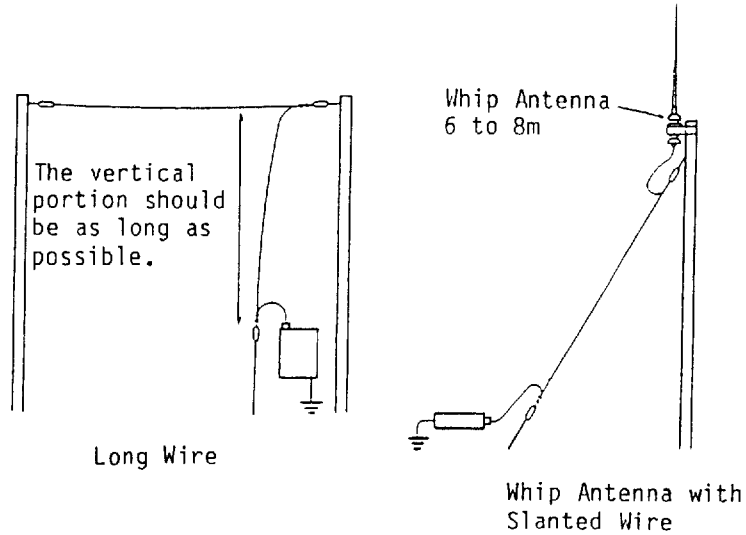

Figure 1-4 Long wire and whip antenna installations

Anti-moisture measure (vent tube)

The vent tube (supplied) prevents moisture from being drawn into the enclosure during atmospheric pressure changes and allows trapped humid air to escape. Install it according to coupler installation method, before mounting the coupler.

Vertical or horizontal installation

Two vent holes are provided on the coupler, one at the bottom and one on the rear. These are vent holes **(B)** and **(A)** in Figure 1-5. The vent tube is set to vent hole **(B)** at the factory. This location is for vertical installation of the coupler. For horizontal installation, remove the vent tube from vent hole **(B)** and set it to vent hole **(A)**. Cover vent hold **(B)** with seal (supplied), from inside the coupler.

Overhead installation

Drill a hole of 8 mm diameter in the front cover and mount the vent tube there. See Figure 1-5.

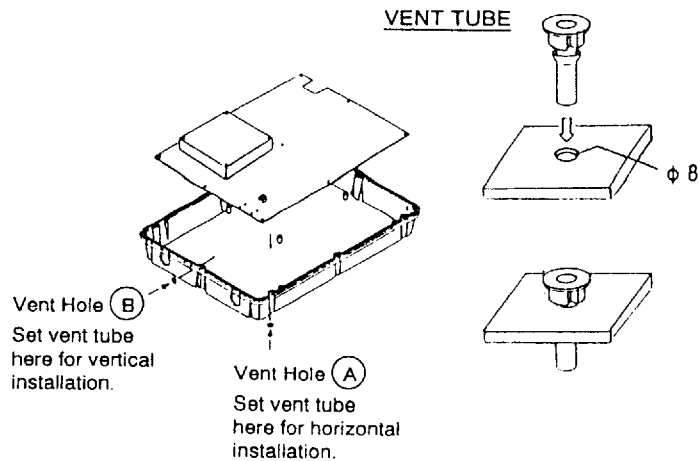
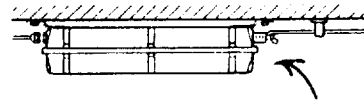
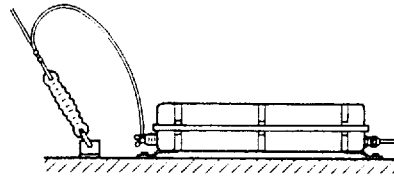
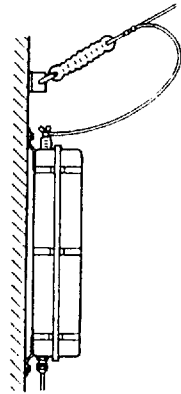

Figure 1-5 Mounting the vent tube

OVERHEAD INSTALLATION

Mounting

The antenna coupler can be fixed to the floor, bulkhead, overhead or mast. For mounting on the bulkhead, floor or ceiling, fix the coupler with either tapping screws or M5 bolts and nuts. For mounting on the mast, use two U-bolts (optional supply).



INDOOR INSTALLATION ONLY

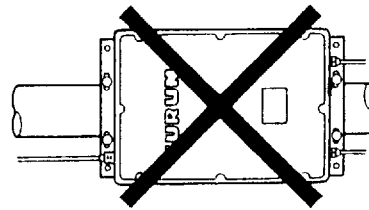
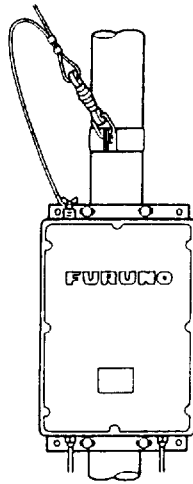

Figure 1-6 Typical antenna coupler installations

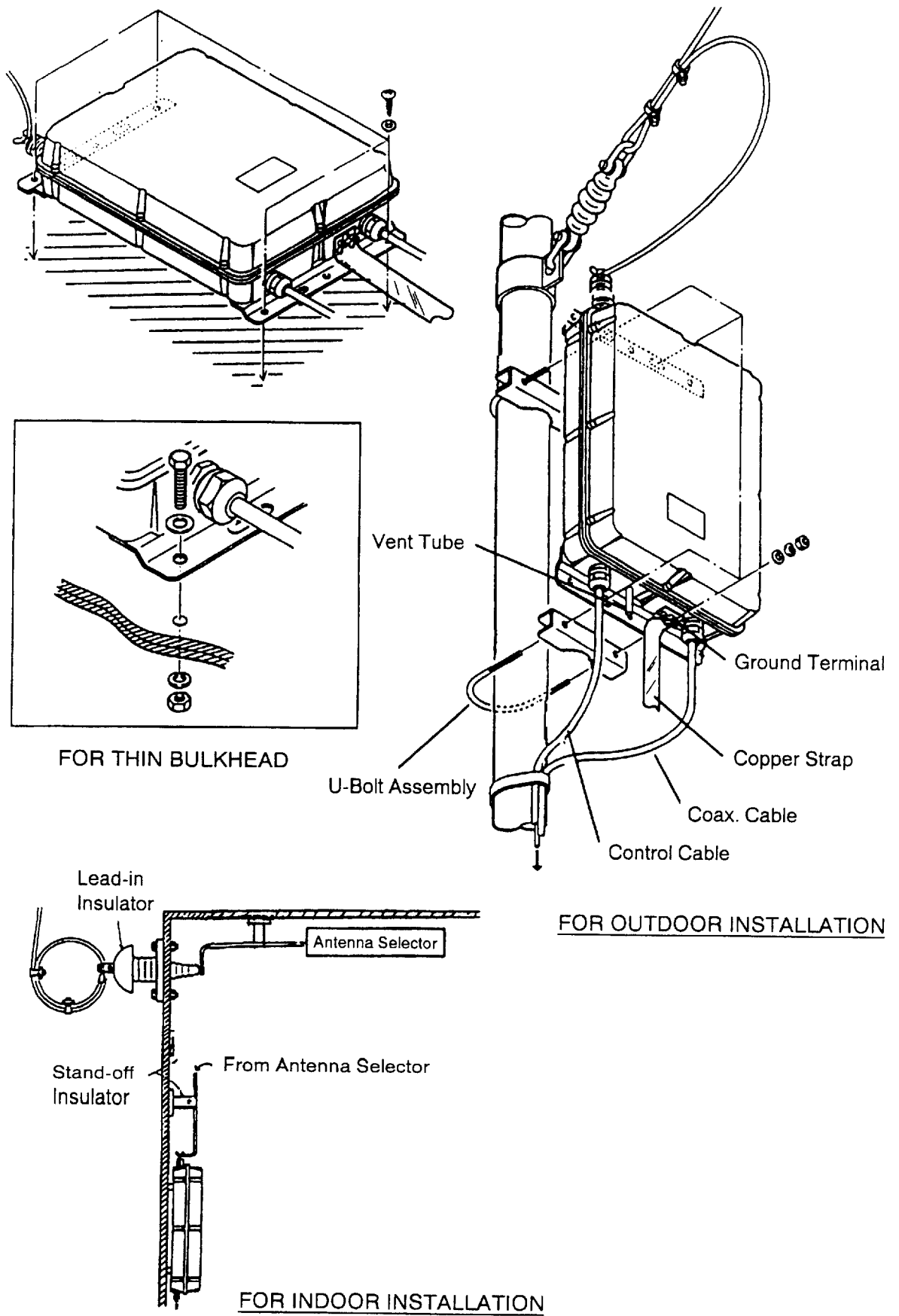

Figure 1-7 Mounting the antenna coupler

1.3 Fan Kit and Piggy-Mount Hanger

Fan kit

Mounting

The Fan Kit provides cooling air for the transceiver. Install it by referring to the outline drawing on page D-6.

Connection

Insert the 2P connector from the Fan Kit into the "FAN" cable entrance at the rear of the lower chassis of the transceiver as shown below. Connect it to the FAN terminal J16 of the TX/RX board.

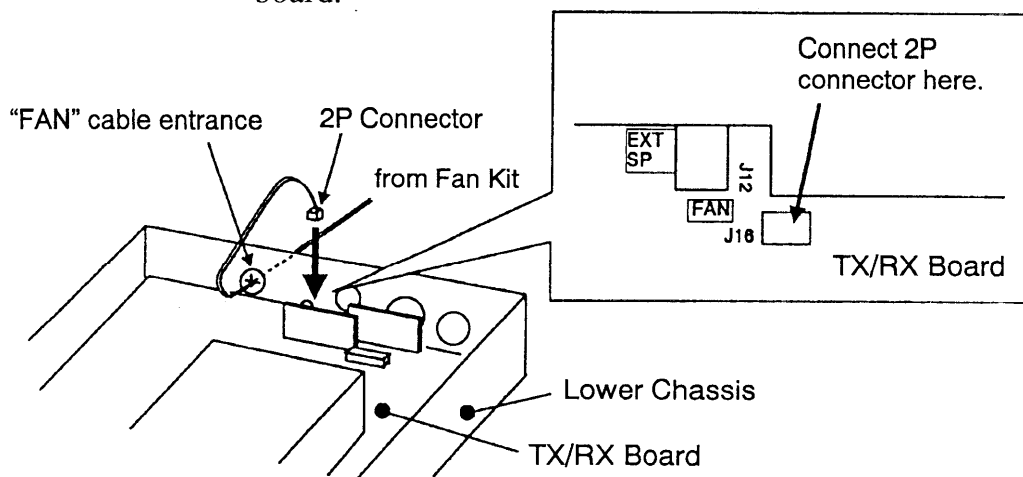

Figure 1-8 Connection of the Fan Kit

Piggy-mount hanger

The piggy-mount hanger permits piggyback mounting of the transceiver together with the FURUNO DSC-60 DSC Terminal. Install it by referring to the outline drawing on page D-7.

When the Fan Kit is required, connect it to the FS-1562 referring to the procedure shown above. If the fan kit is not installed, only the top cover is supplied.

1.4 Ground System

Introduction

A good antenna can work well only when an efficient RF ground is provided. Without a good ground system, the full potential of this radio cannot be realized.

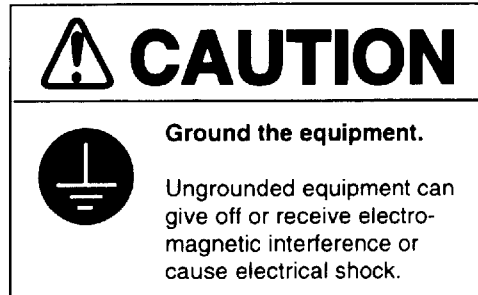

- **CAUTION:** *Lack of ground connection or a long ground lead may allow the ground terminal of the antenna coupler to reach a high RF voltage with respect to ground, resulting in a safety hazard.*

Ground for metallic hull

Run a copper strap (supplied) between the ground terminal of the antenna coupler and the ship's superstructure.

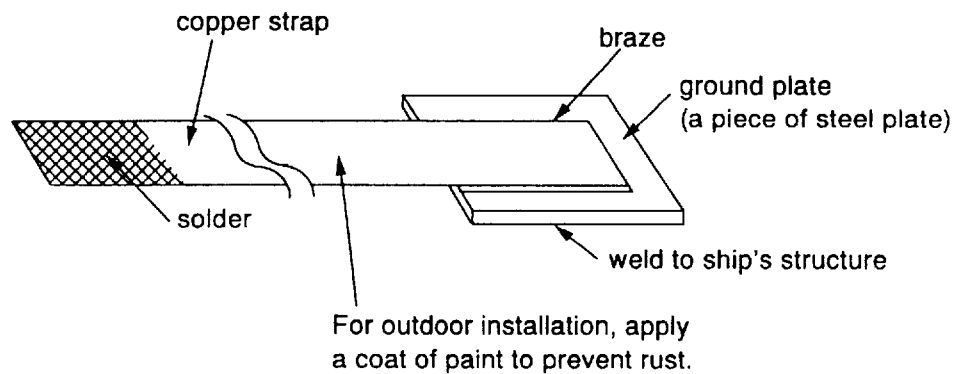

Figure 1-9 Ground for metallic hull

Ground for non-metallic hull

Run a copper strap (supplied) between the ground terminal of the antenna coupler and the radio ground system.

Transceiver / Power Amp ground

Ground the transceiver and the power amp unit with the ground wire (supplied), to prevent interference and protect against lightning.

1.5 The Antenna

Introduction

The antenna plays the most important role in radio communication. If it cannot receive or transmit effectively because of improper installation, even the most sophisticated transceiver will be rendered useless.

Types of antennas

There are various types of SSB antennas. The most commonly used are a long wire and a whip. Whatever antenna is to be used, the antenna coupler can tune a long wire or whip whose total length is 7 to 30 meters (23.3 to 100 feet). Although a longer antenna is preferable when the radio is operated only on low frequencies, use this size of antenna to ensure stable automatic tuning on all bands.

Long wire antenna

A long wire antenna is inexpensive and in general provides better performance than a whip antenna, provided the vertical part is long enough.

Whip antenna

A whip antenna is easier than a long wire antenna to install and provides good overall coverage of most SSB frequencies. In fact, if you don't plan to venture more than 500 miles from shore and the ground system is excellent, a simple 7 meter (23 feet) whip antenna will probably suffice. A whip is installed as high as possible, away from any nearby objects.

- **WARNING:** *Touching a transmitting SSB antenna can cause severe burn or shock.*

Mounting considerations

When selecting a mounting location;

- The length of the vertical portion should be longer than 4 meters, and the slant angle of that part should be within 10 degrees. Separate it as far as possible from:
 - stays
 - metallic objects
 - direction finder antenna
 - INMARSAT radome antenna
- Locate the insulator away from funnels and masts.
- If the antenna coupler is installed outdoors, use a lead-in insulator (FURUNO type YA-150(150W) or YA-218(250W)) to make the connection. If necessary, use a high quality antenna switch and stand-off insulator.
- If the antenna is connected directly to the coupler, use a strain insulator to prevent insulator fatigue.

1.6 Power Amp Unit (PA-2500, 250W only)

Mounting Considerations

When selecting a mounting location, keep in mind the following points.

- Select a location which provides adequate ventilation.
- The location should be clean and dry.
- The mounting location must be able to support the weight of the unit(6kg) under the conditions of vibration normally encountered aboard the vessel.

Mounting

The mounting dimensions of the Power Amp Unit are shown in Figure1-10.

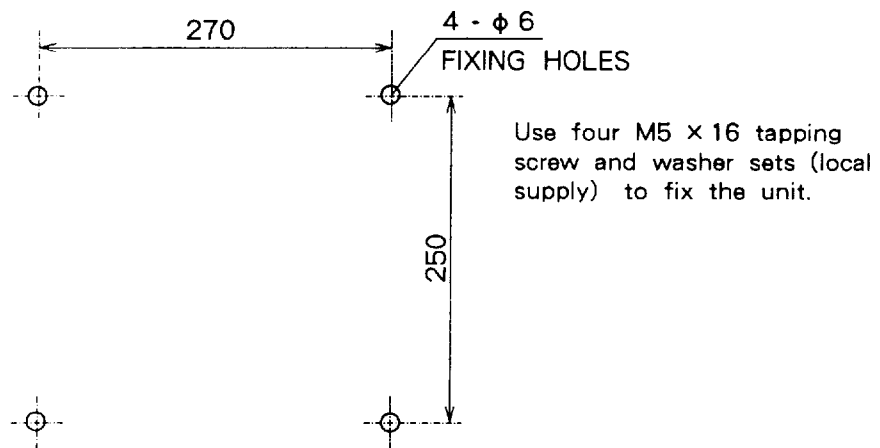

Figure 1-10 The mounting dimensions of Power Amp Unit

1.7 Power Supply Unit (option)

Mounting Considerations

When selecting a mounting location, keep in mind the following points.

- Select a location which provides adequate ventilation.
- The location should be clean and dry.
- The mounting location must be able to support the weight of the unit (PR-300:14.5kg, PR-850/PR-850A:35kg) under the continued conditions of vibration normally encountered aboard the vessel.

Mounting

Refer to the outline drawings attached.

Chapter 2 Connections

2.1 Connection of Units

Refer to the interconnection diagram on page 2-4 to 2-6.

2.2 Power Cable

The FS-1562 comes with a 2-meter power cable with built-in 20A fuses. If a longer cable is necessary, it should be as thick as possible to prevent voltage drop.

2.3 AC-DC Power Supply Unit (PR-300 for 150W set)

Introduction

To the AC-DC Power Supply Unit (PR-300), both 100/110/200/220VAC and 24VDC are supplied. When AC input fails, DC power is directly supplied.

For GMDSS vessels, 24VDC power must be supplied through the radio battery.

Changing tap connections

Change the tap connections of the transformer as shown below, in accordance with the input voltage.

Changing fuse

Change the fuse as shown below, in accordance with the ship's mains.

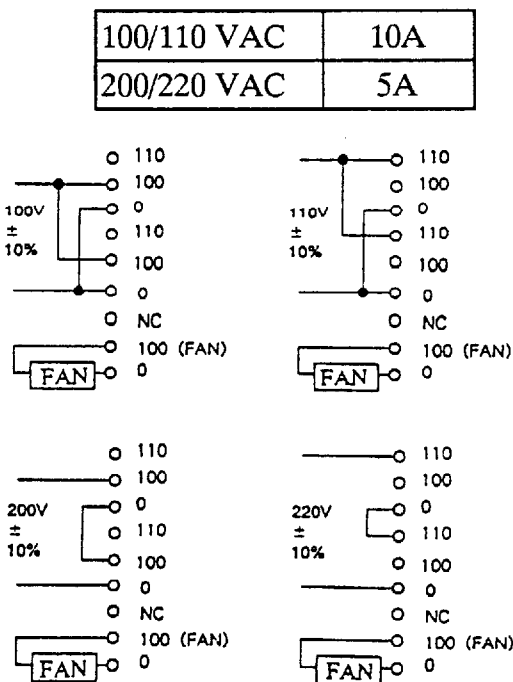

Figure 2-1 Tap connections in the PR-300

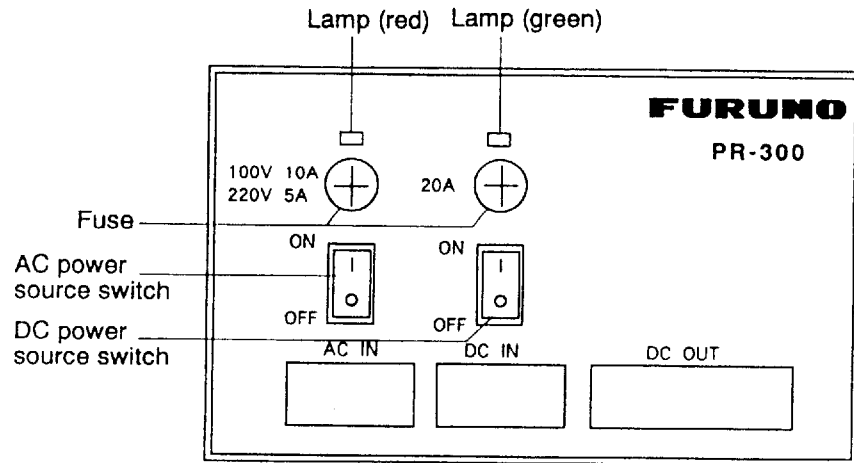

Figure 2-2 AC-DC power supply unit PR-300

Ground

Connect a ground wire between ship's superstructure and a fixing hole on the PR-300.

2.4 Power Supply Unit (PR-850/PR-850A for 250W set)

Introduction

To the Power Supply Unit PR-850, 100/110/120/200/220/240VAC is supplied.

To the Power Supply Unit PR-850A, both 100/110/120/200/220/240VAC and 24VDC are supplied. When AC input fails, DC power is directly supplied. For GMDSS vessels, 24VDC power must be supplied through the radio battery.

Wiring

Connect cables to the input terminal on the front panel, using crimp-on lugs. For connections to output terminals, bend crimp-on lugs so they do not contact the terminal board cover.

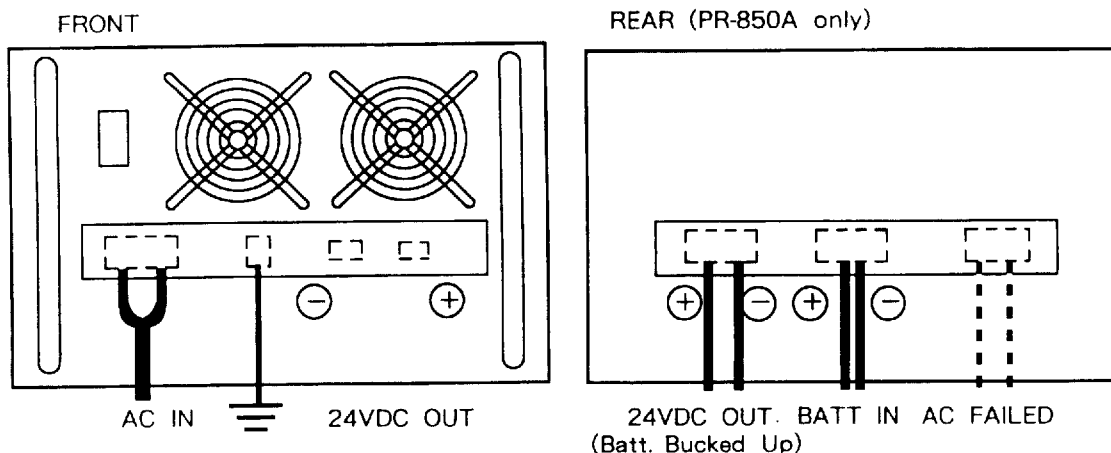

Fig. 2-3 Connections on PR-850/PR-850A

Selection of Input Voltage

The input voltage is adjustable for 100/110/120/200/220/240 VAC, and is factory-set for 220 VAC. To select other input voltages, open the top cover and change the wiring according to the figure below. After changing the input voltage, correct the front panel sticker accordingly.

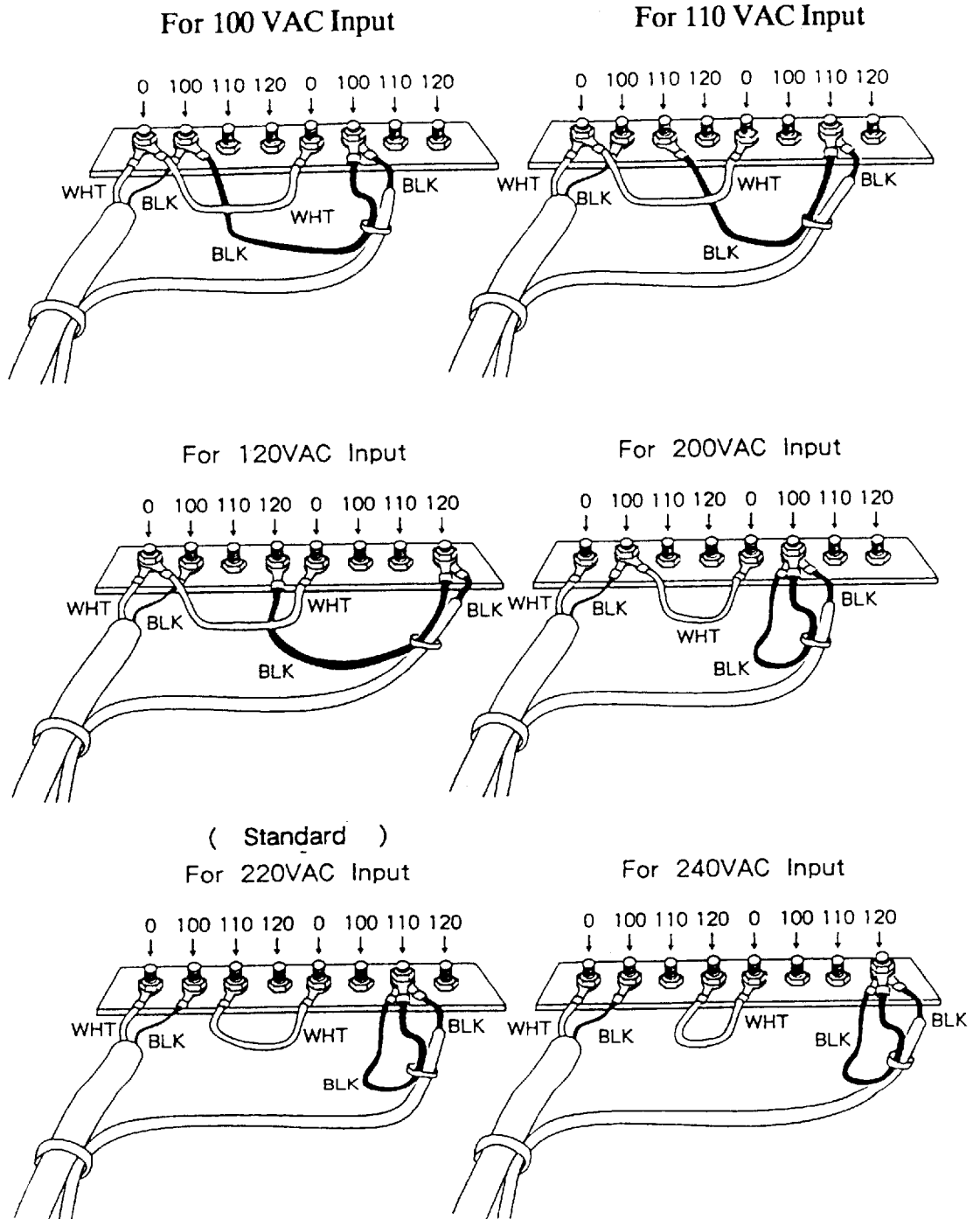

Figure 2-4 Selection of Input Voltage on PR-850/PR-850A

Ground

Connect a ground wire between ship's superstructure and a fixing hole on the PR-850/PR-850A.

FS-1562-15(150W)

Note:

Metallic Hull: Weld steel plate w/copper strap to ship's superstructure.
 Non-metallic Hull: Connect to radio ground system.

Total length of antenna should be 7 to 30 meters.

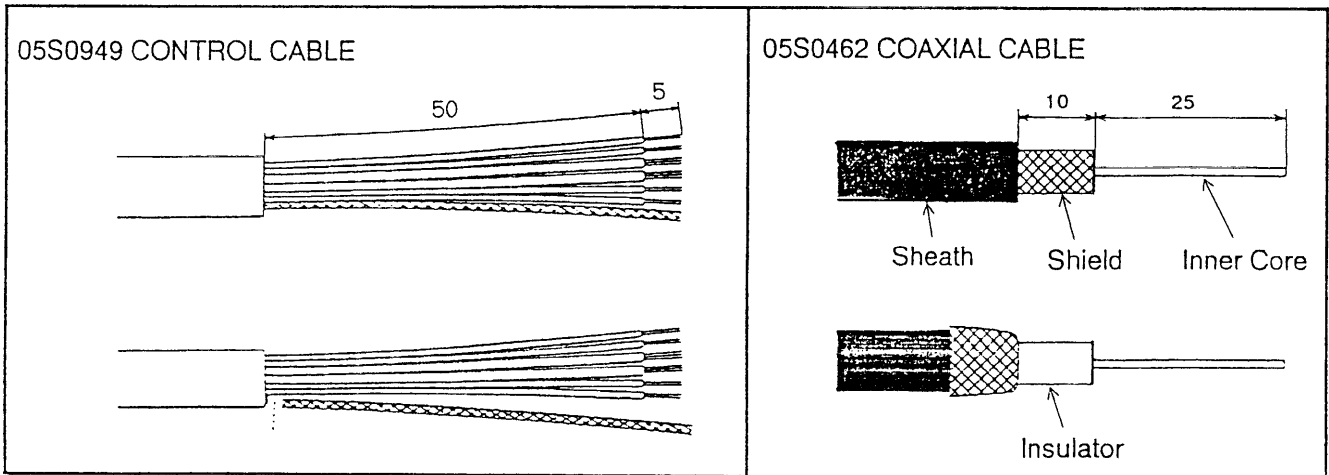
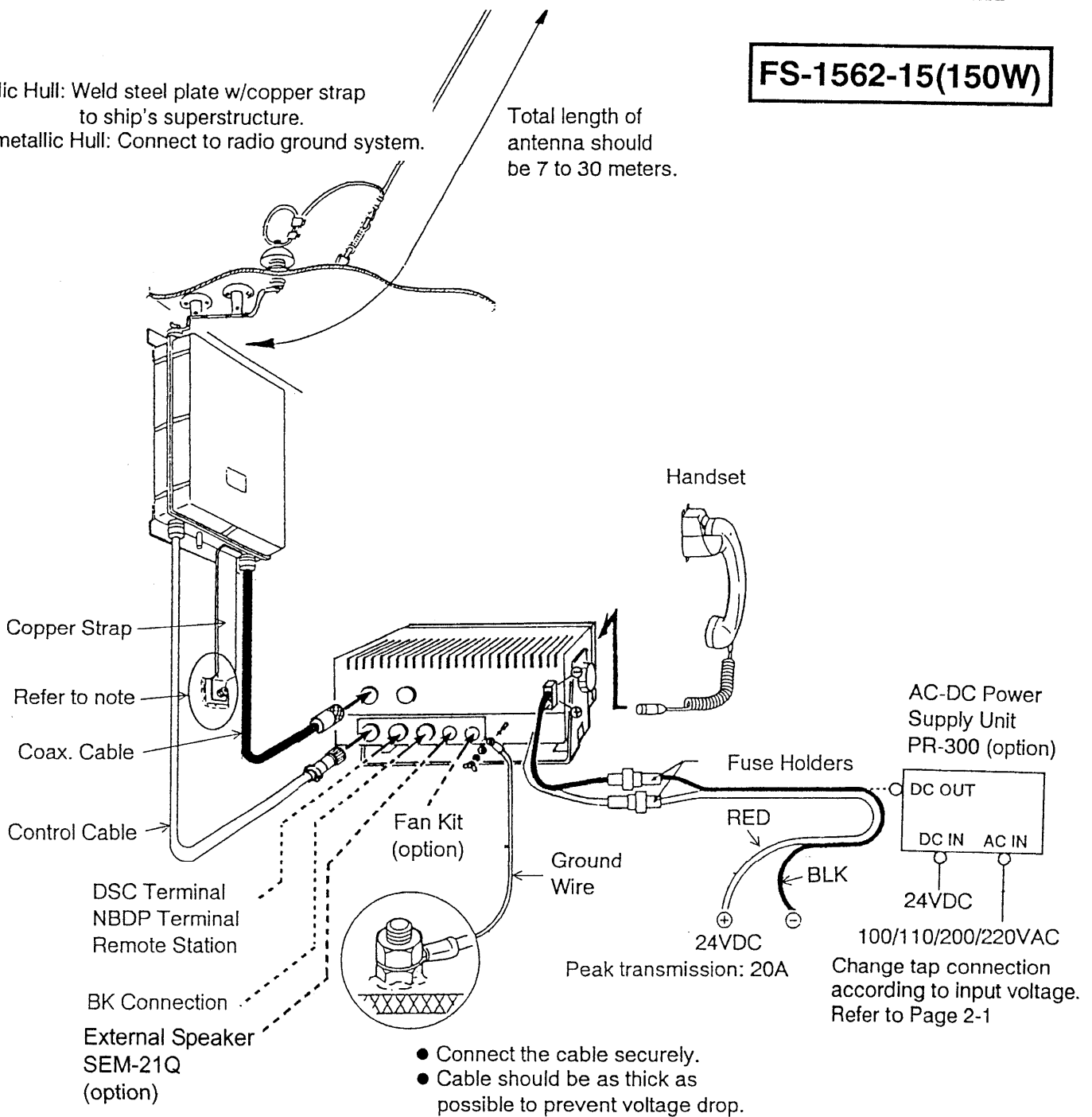

Figure 2-5 Connections for FS-1562-15(150W) set

Note:
 Metallic Hull: Weld steel plate w/copper strap
 to ship's superstructure.
 Non-metallic Hull: Connect to radio ground system.

FS-1562-25(250W)

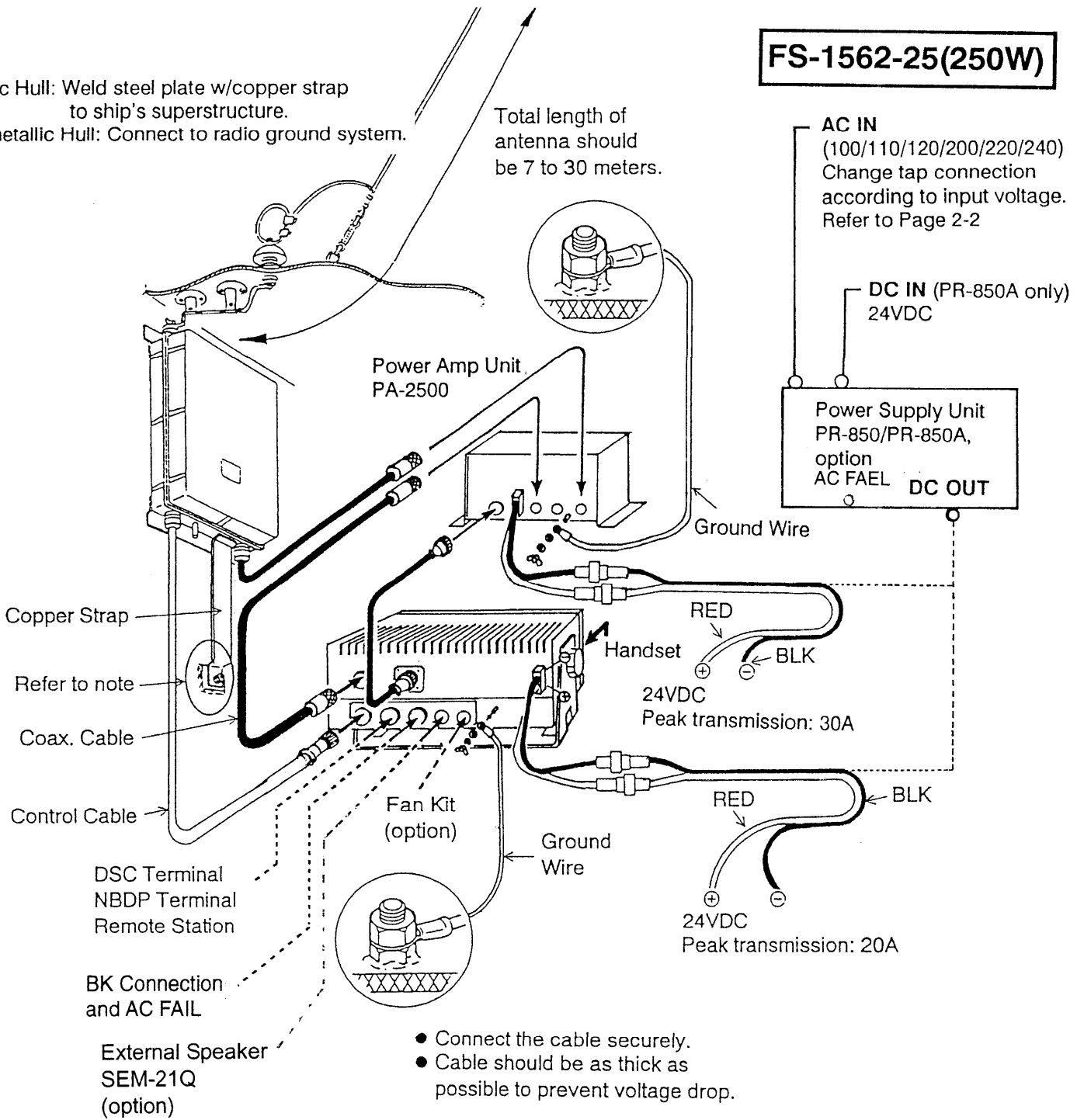

Figure 2-6 Connectons for FS-1562-25(250W) set

AT-1560-15
AT-1560-25

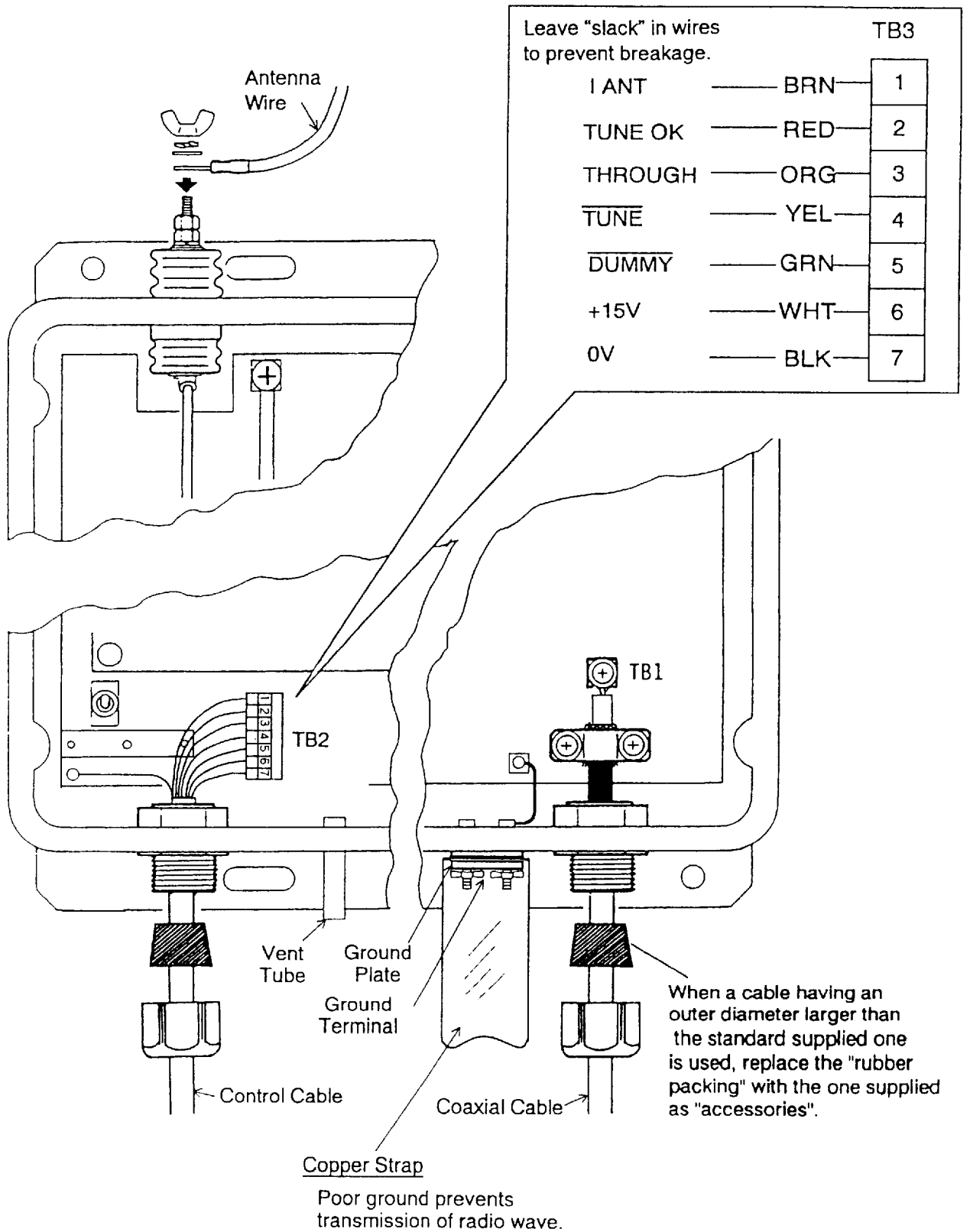

Figure 2-7 Wiring on the Antenna Coupler

2.5 Installation of the AC FAIL Board (option)

The AC FAIL Board functions to, when the FS-1562 operates on AC power through Rectifier PR-850A, automatically reduce Tx Power when AC power fails.

Procedure

1. Turn off the power. Disconnect the antenna and power cable.
2. Unfasten two screws on the upper chassis and four screws on the lower chassis to open the upper chassis.

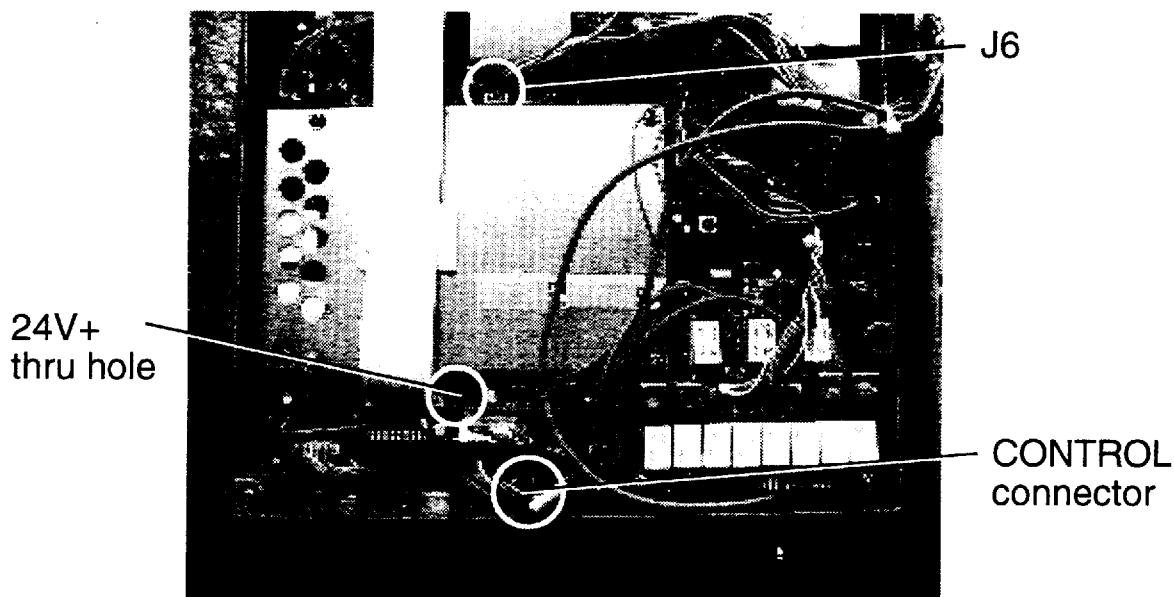

Top view of the lower chassis

3. Fasten the AC FAIL Board with a screw from the PRESELECTOR Board as shown below.

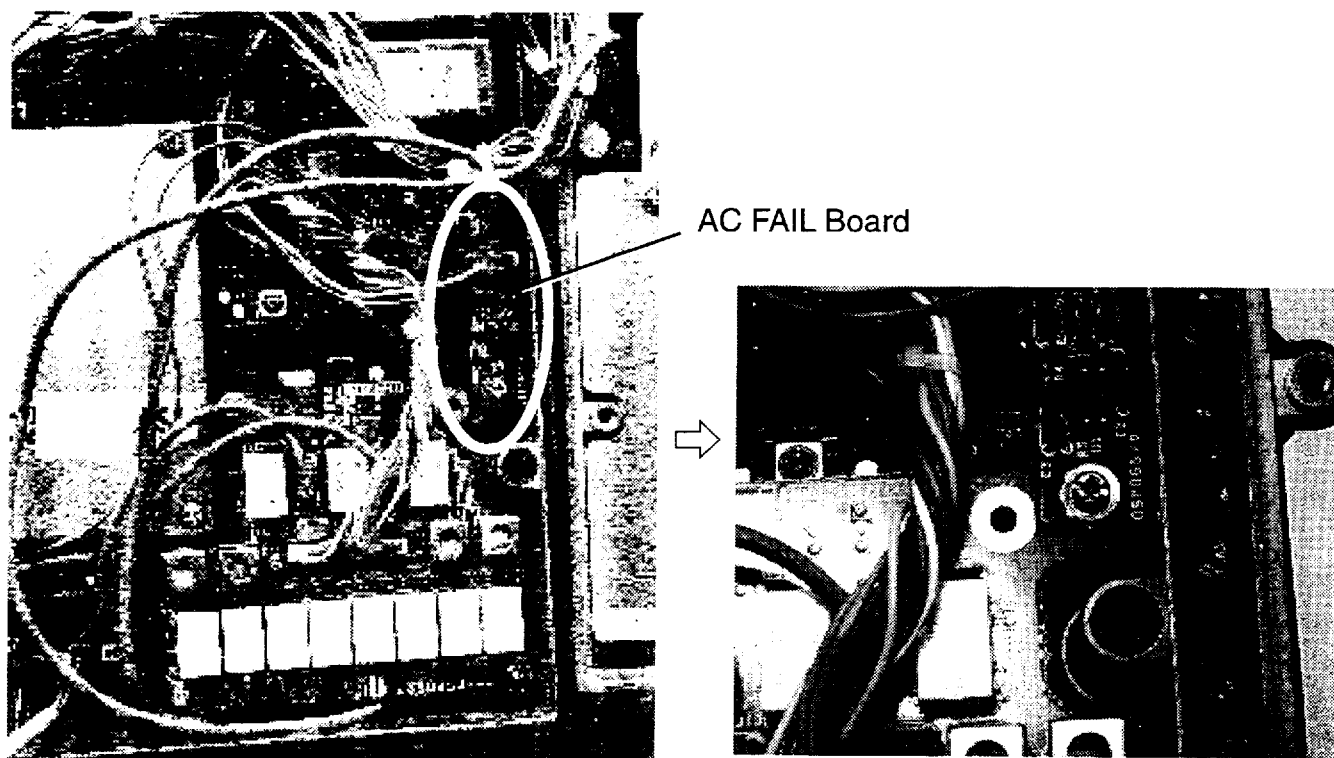

4. Solder the brown wire from the AC FAIL Board to the "24V+" thru hole on the TX/RX Board as shown below.
5. Remove small section of vinyl form red wire of control connector.
6. Solder the red wire from the AC FAIL Board to the red wire of control connector (Refer to page S-5).

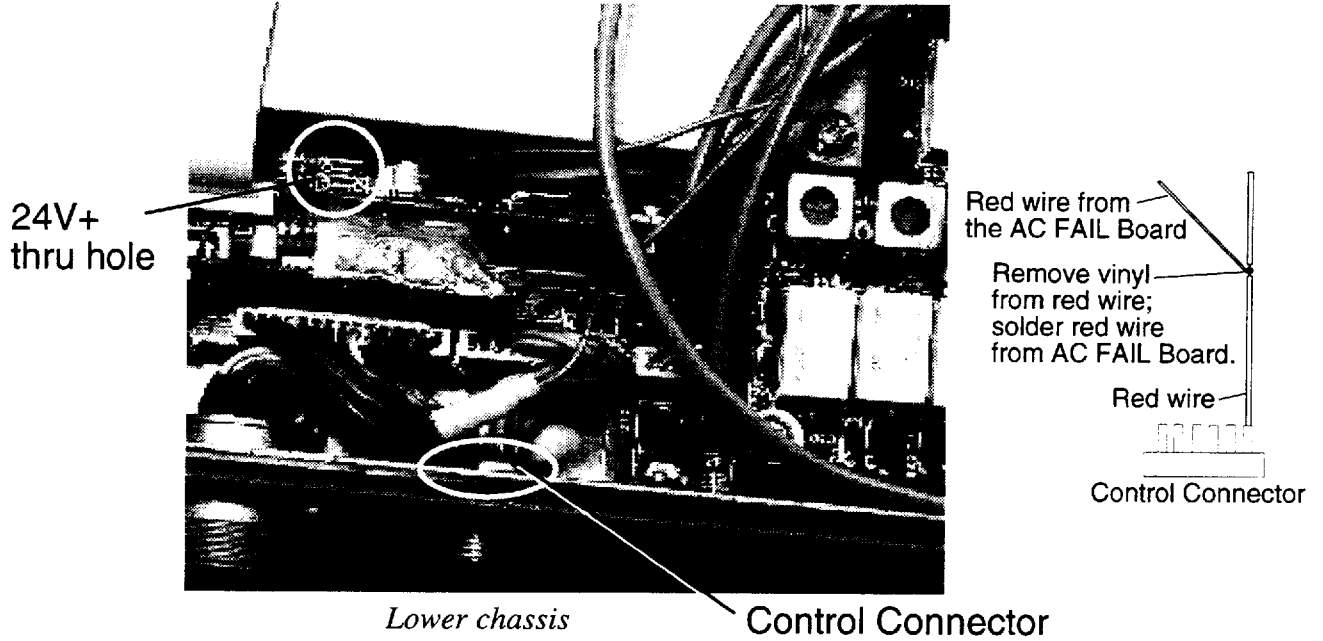

7. Tape soldered part.

8. Remove small section of vinyl from yellow wire of J6 on the TX/RX Board.
9. Solder the blue wire from the AC FAIL Board to the yellow wire of J6 on the TX/RX Board.
10. Tape soldered part.
11. Remove small section of vinyl from red wire of J6 on the TX/RX Board.
12. Solder the green wire from the AC FAIL Board to the red wire of J6 on the TX/RX Board.
13. Tape soldered part.
14. Remove small section of vinyl from orange wire of J6 on the TX/RX Board.
15. Connect the yellow wire from the AC FAIL Board to the orange wire of J6 on the TX/RX Board.
16. Tape soldered part.

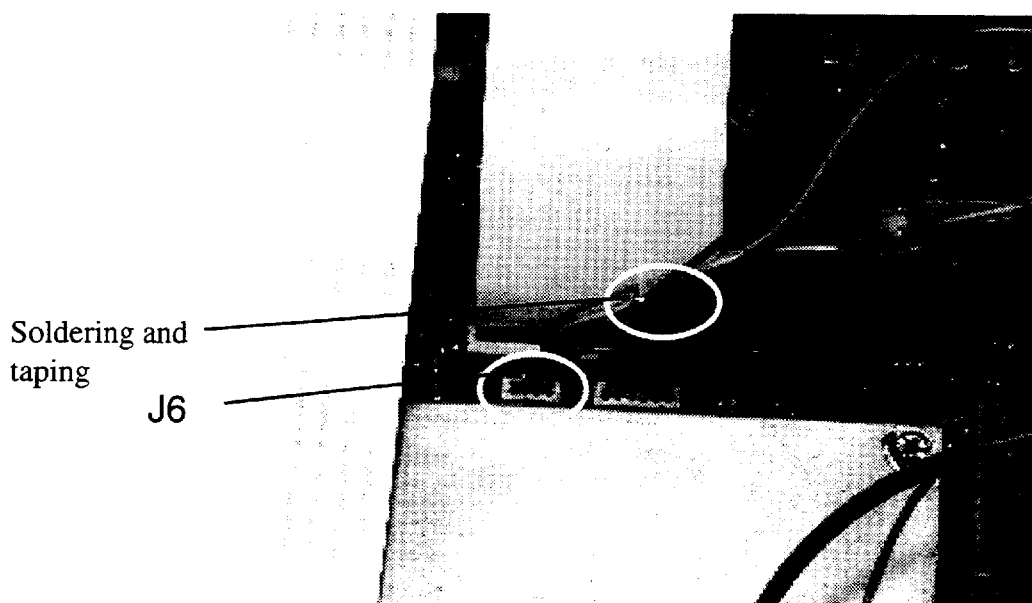

Lower chassis

Chapter 3 Connection of External Equipment

3.1 NBDP Terminal DP-6

The DP-6 has a remote control function which automatically sets class of emission and frequency data at the FS-1562.

Remarks on connection

Connect the DP-6 to the FS-1562 with a 13-pair twisted cable. FURUNO can supply this cable in lengths of 1 m, 3 m or 5 m and with or without connector. For the cable with no connectors, attach connector types SRCN (FS-1562 side) and D-sub (DP-6 side). And for the cable with connectors, detach the D-sub connector at the FS-1562 end of the cable and connect the wires to the SRCN connector on the FS-1562.

3.2 DSC Terminal DSC-60

Connect the DSC-60 to the REMOTE terminal of the FS-1562.

Remarks on connection

When both the DP-6 and DSC-60 are to be connected, connect via the Distributor DB-120. Refer to page S-3.

3.3 Remote Station RB-500

To enable connection of the RB-500, the REMOTE-A Board is replaced at the factory with the REMOTE-B Board (current loop). If more than two RB-500s are to be installed, connect them via the Distributor DB-500. Refer to page S-2 for connection.

3.4 Distributors(DB-500/DB-120)

DB-500

The DB-500 enables connection of four external equipment: one NBDP, one DSC and two remote stations (see Figure 3-1), or four remote stations. For further details, refer to the installation manual for the DB-500.

DB-120

The DB-120 enables connection of two external equipment: one NBDP and one DSC terminal. Refer to the interconnection diagram on page S-4.

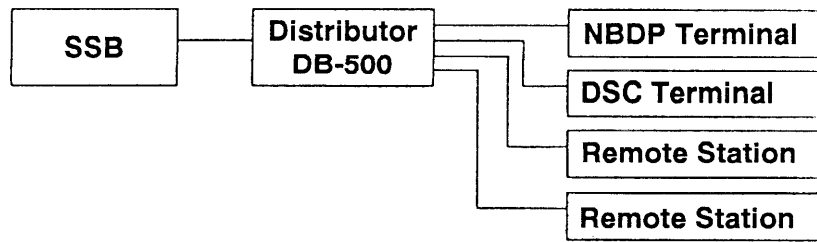

Figure 3-1 Connection of Distributor DB-500





3.5 BK (Break-in) Connection

Introduction

BK connections necessary when the FS-1562 is installed together with a HF receiver or transceiver. The BK relay (circuit) functions to mute the receiver when it and the FS-1562 are operated together. With no BK connection, the receiver or transceiver may generate noise or its front end may be damaged by strong signals when the radio is transmitted. For connection of BK Interface (BK-300) with FS-1562, refer to Installation manual of BK Interface (IMC-50830).

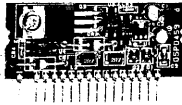
Parts required

The BK relay kit consists of the following parts. (FS-1562-15 optionally supplied)

Name	Type	Code No.	Figure
CONTROL Board	05P0459	005-517-520	
Connector Assy.	05S0846-0	000-125-319	
Gasket	05-029-0122-2	100-878-420	
Washer	16.2x22.0x0.5 SUS 304	000-801-849	

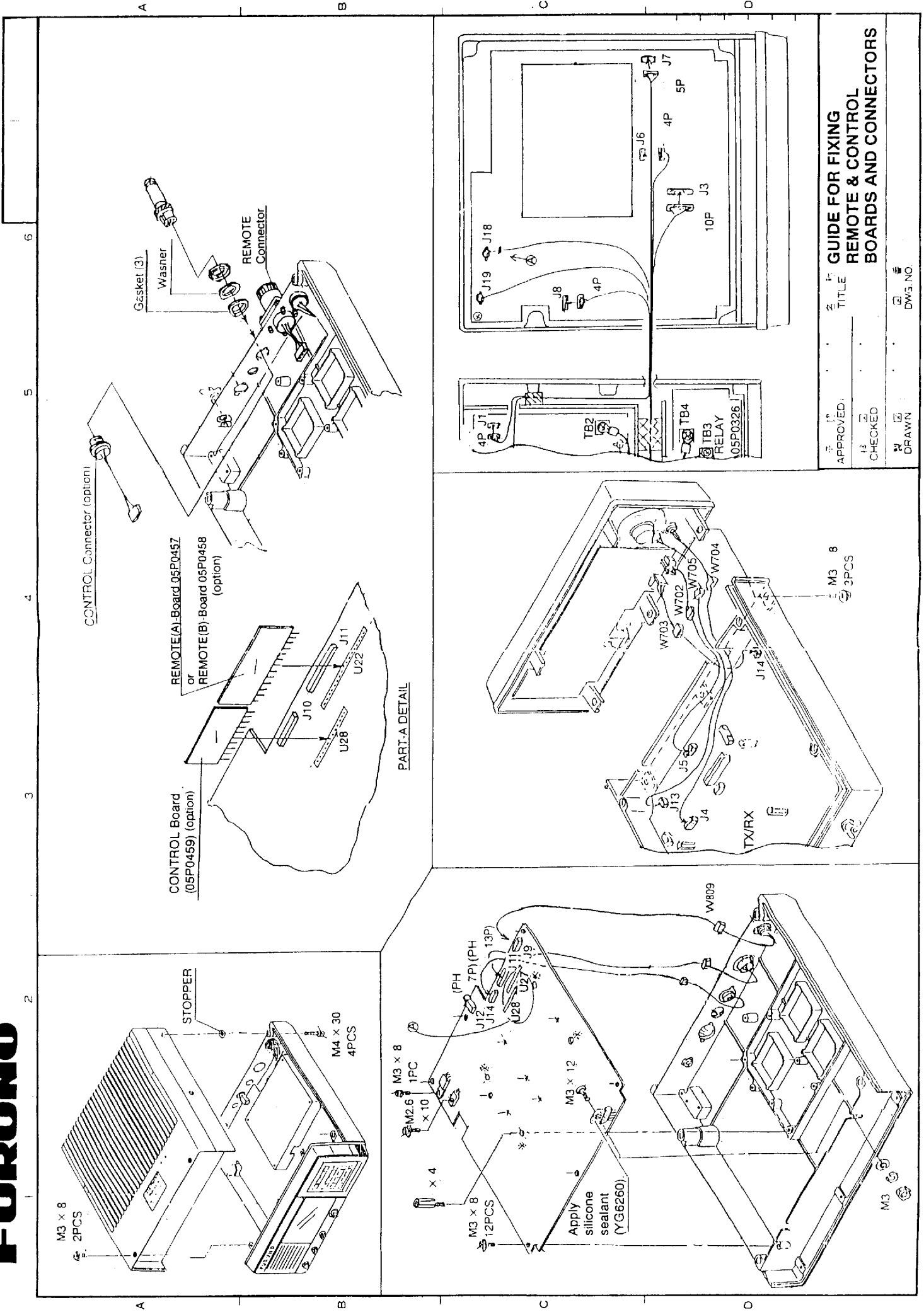

GUIDE FOR FIXING REMOTE & CONTROL BOARDS AND CONNECTORS

APPROVED: _____ TITLE _____

CHECKED: _____

DRAWN: _____ DWG. NO. _____

Connection of floating ground radiotelephone (FS-5000, etc.)

Connect the FS-1562 to the FS-5000 with a connection cable of 0.75mm² or larger (3C cable, or equivalent), as shown in Figure 3-2.

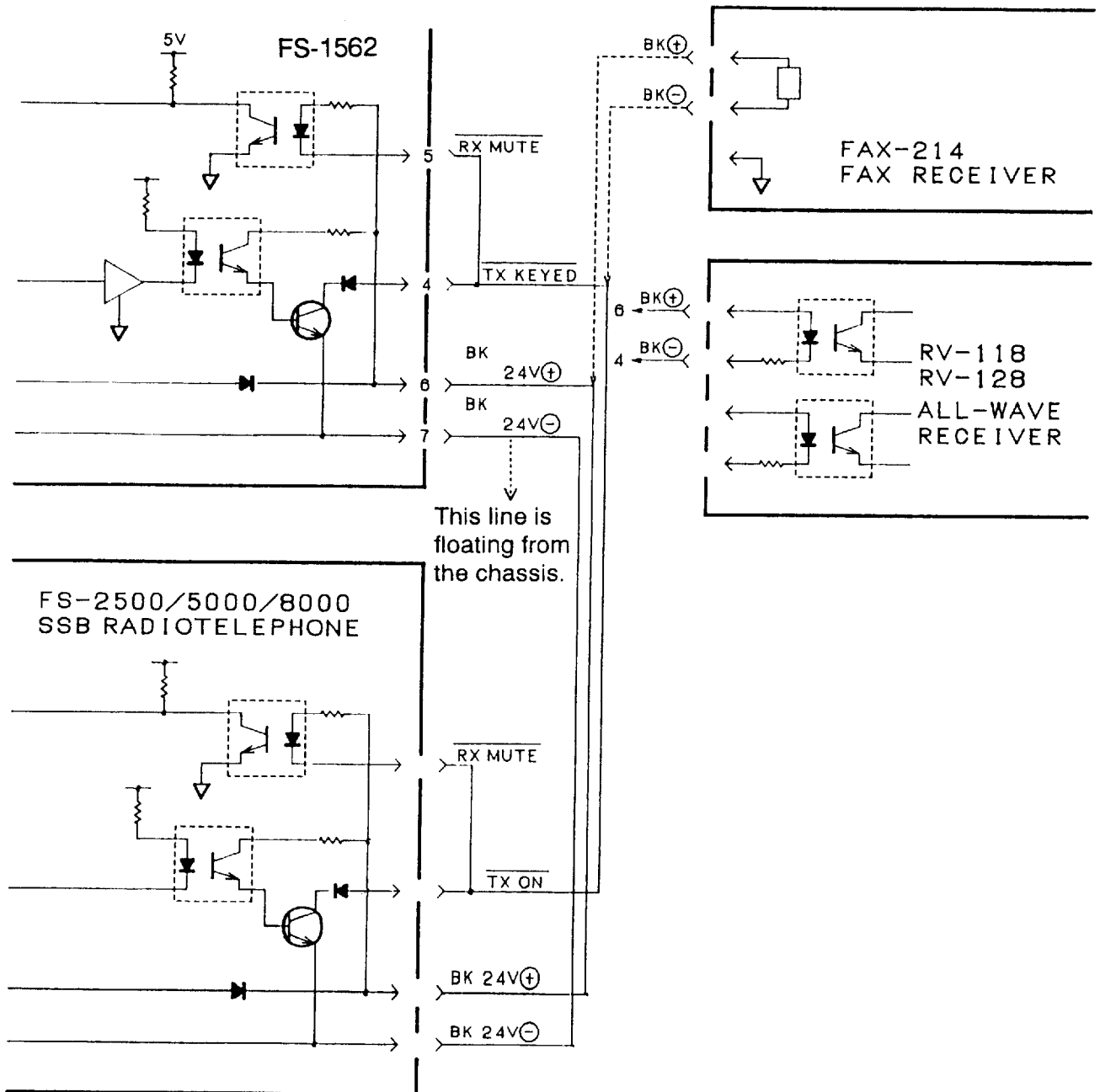

Figure 3-2 Connection of floating ground radiotelephone

Chapter 4 Installation Checks

4.1 Introduction

After completing the installation, check the FS-1562 and all units connected to it for proper connection and operation.

4.2 Visual Check

Before turning on the radiotelephone, visually check it as follows.

Antenna

- Are fixing bolts, wire clips, shackles securely tightened?
- Are the antenna and/or coaxial lead-in waterproofed?
- Is the antenna wire securely connected to the coupler?
- Make sure no mechanical stress is applied to the antenna terminal of the antenna coupler.

Antenna coupler

- Is the unit perfectly grounded by using a copper strap?
- Is the vent tube installed in proper location?
- Are all wirings correctly made?

Transceiver

- Is the unit grounded with the supplied ground wire? Length of the wire is as short as possible? If length of the wire is long, use copper strap. (local supply)
- Are all wirings correctly made?
- Are all connectors securely tightened?

Power Amp Unit (250W only)

- Is the unit grounded with the supplied ground wire? Length of the wire is as short as possible? If length of the wire is long, use copper strap. (local supply)
- Are all wirings correctly made?
- Are all connectors securely tightened?

4.3 Self-test

Carry out self-test, referring to PART 2 of the Operator's Manual.

4.4 Performance Check

Receiver

1) Set the controls on the front panel as follows.

Speaker:	ON	Squelch:	OFF
AGC:	ON	Sensitivity:	Max

- 2) Confirm that a signal can be received on each band. If noise or signal is weak, check the antenna lead-in section, coaxial cable connection and ground connections.

Transmitter

- 1) On each band, confirm that the antenna is automatically tuned when the [TX TUNE] key is pressed. ("OK" appears when tuning is completed successfully.) Automatic tuning time of the antenna should take no longer than 15 seconds. If you find a channel which takes more than 15 seconds to tune, recheck antenna length.
- 2) Communicate with the handset, confirming that antenna current (IA) changes with voice level.

4.5 User Channel

Register permitted frequency, referring to the Service Manual.

4.6 Manual 2182 kHz Tuning Preset

For safety measure, it is required that 2182 kHz be tunable both automatically and manually. The setup to enable manual tuning, in the event the antenna tuner system fails, is made with the DIP switches in the Antenna Coupler.

Call a coast station and tell your situation. Be sure not to transmit during silent period (00 to 03 min. 30 to 33 min. of every hour).

1. Remove the top cover of the Antenna Coupler. Set the Manual- AUTO switch (Coupler Board) to AUTO.

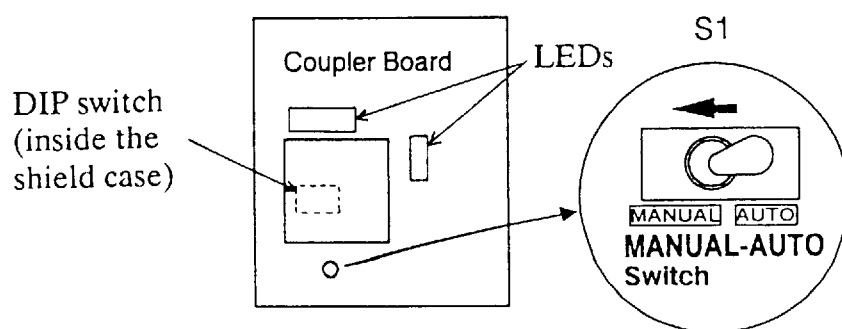

Figure 4-1 MANUAL-AUTO Switch on the Coupler Board

2. Turn the Transceiver on.
3. Press the 2182 key.
4. Press the TX TUNE key. "TUNE" appears on the LCD. "OK" appears when tuning is completed. Record the status (on or off) of LEDs CR1-CR22 on the Coupler board.
5. Set S1 to MANUAL.

6. Set DIP Switches S4 thru S6 according to LED status recorded in step 4.

DIP Switch		LED
S4	#8	CR1
	7	CR2
	6	CR3
	5	CR4
	4	CR5
	3	CR6
	2	CR7
	1	CR8
S5	#8	CR9
	7	CR10
	6	CR11
	5	CR12
	4	CR13
	3	CR14
	2	CR15
	1	CR16
S6	#8	CR17
	7	CR18
	6	CR19
	5	CR20
	3	CR22

Be sure that S6 #1 is set to "OFF" any time.

7. Return the switch to AUTO, confirming that LEDs do not change. If different, repeat step 6.
8. Set S1 to MANUAL.
9. Making sure it is not silent time, communicate with the handset. Confirm that IA changes with voice level.
10. Set S1 to AUTO. Close the cover of the Antenna Coupler.

■ **Note:** *If necessary a frequency other than 2182 kHz can be selected as manual tuning frequency. Similar to the above procedure record the status of LEDs CR1-CR22 during automatic tuning of an often-used frequency and set DIP Switches S4 to S6 according to LED status.*

4

3

2

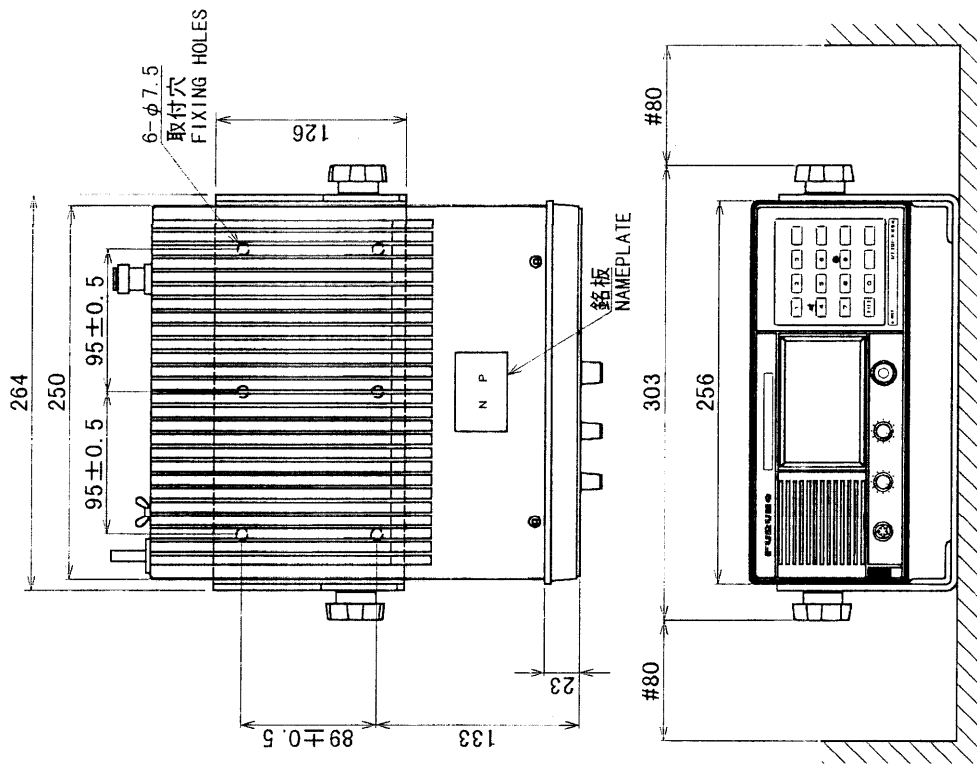

寸法区分 (mm) DIMENSION	公差 (mm) TOLERANCE
$0 < L \leq 50$	± 1.5
$50 < L \leq 100$	± 2.5
$100 < L \leq 500$	± 3

表 1
TABLE 1

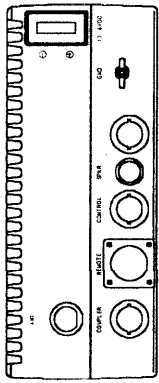

背面図
REAR VIEW

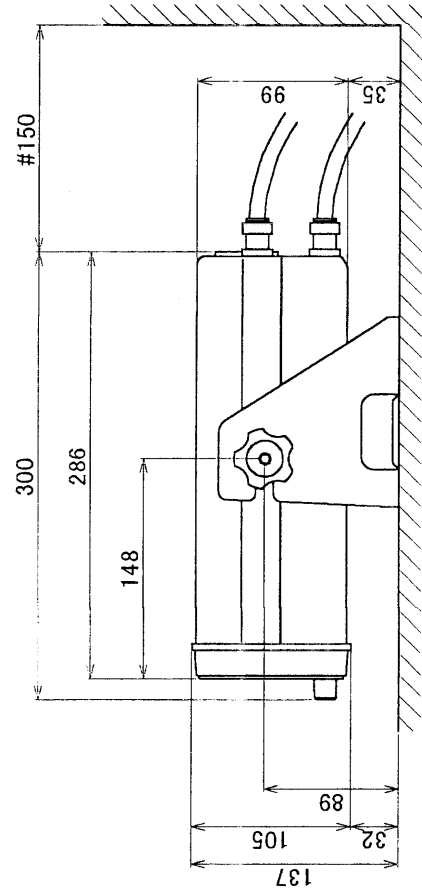

注 記 1) #印寸法は最小サービス空間寸法とする。

2) 指定外の寸法公差は表 1 による。

3) 取付用ネジは M6 ボルトまたはコーチボルト呼び径 6 を使用のこと。

4) 装備ケーブルはサービス時、本体を前方に十分引き出せるよう余裕を持たせること。

NOTE 1. #: RECOMMENDED SERVICE CLEARANCE.

2. TABLE 1 INDICATES TOLERANCE OF DIMENSIONS.

3. USE M6 BOLTS OR COACH BOLTS $\phi 6$ FOR FIXING UNIT.

4. KEEP ENOUGH CABLE LENGTH BEHIND UNIT.

DRAWN	Feb. 3 '00 T. Yamada	TITLE	FS-15/75/2550/1552/1562
CHECKED	Feb. 10 '00 K. Yamada	名称	デジタルMF/HF送受信装置
APPROVED	Feb. 10 '00 K. Yamada	外寸図	
SCALE	1/5	NAME	SSB TRANSCEIVER
DMG. No.	C5574-G02-C	OUTLINE DRAWING	
			05-062-3200-60

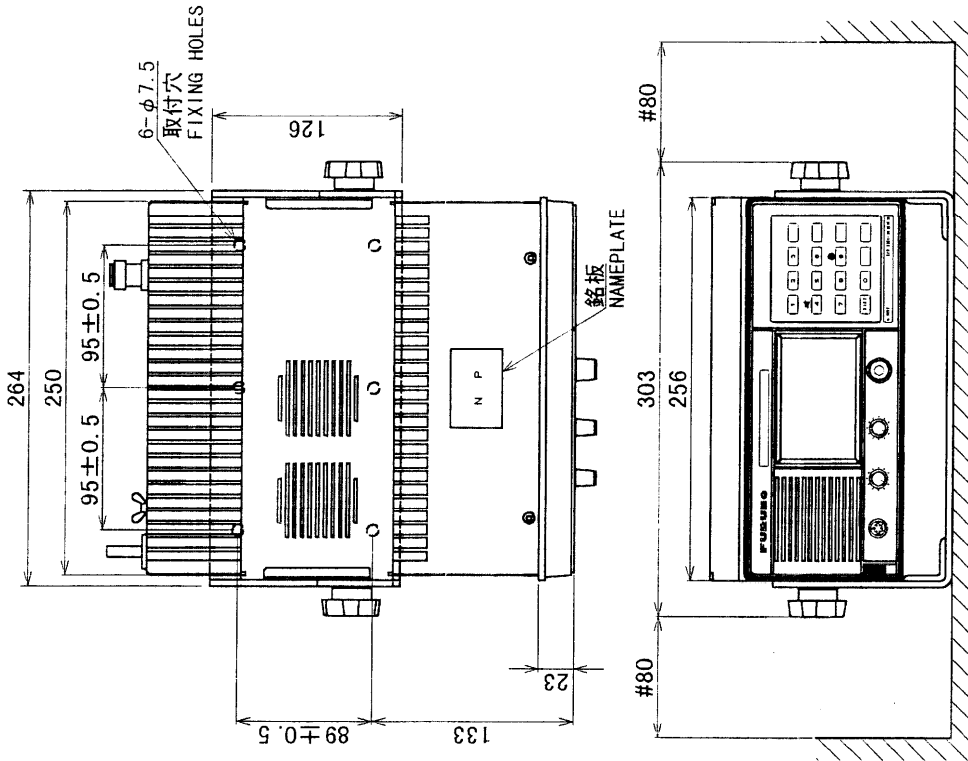

寸法区分 (mm) DIMENSION	公差 (mm) TOLERANCE
0 < L ≤ 50	± 1. 5
50 < L ≤ 100	± 2. 5
100 < L ≤ 500	± 3

表 1
TABLE 1

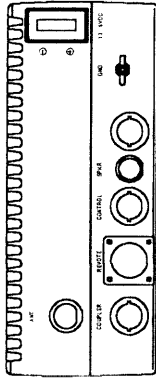

背面図
REAR VIEW

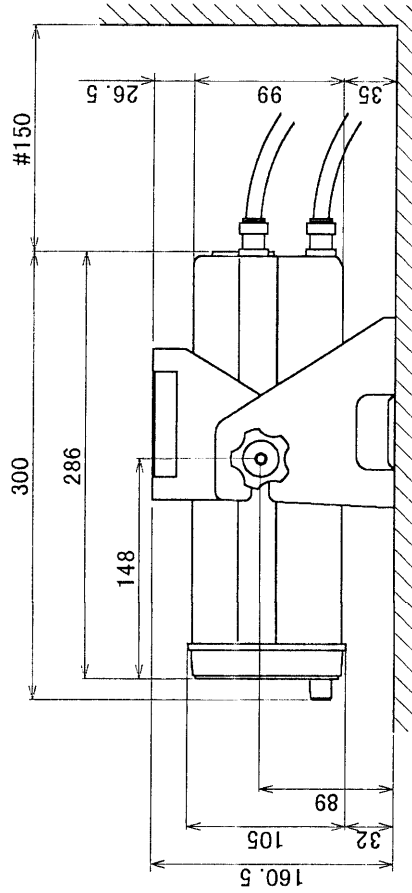

- 注 記
- #印寸法は最小サービスインスレーションとする。
 - 指定外の寸法公差は表 1 による。
 - 取付用ネジは M6 ボルトまたはコーチボルト呼び径 6 を使用のこと。
 - 装備ケーブルはサービスインスレーション時、本体を前方に十分引き出せるよう余裕を持たせること。
- NOTE
- #: RECOMMENDED SERVICE CLEARANCE.
 - TABLE 1 INDICATES TOLERANCE OF DIMENSIONS.
 - USE M6 BOLTS OR COACH BOLTS φ6 FOR FIXING UNIT.
 - KEEP ENOUGH CABLE LENGTH BEHIND UNIT.

DRAWN	Feb 2 1980 T. YAMAGUCHI	TITLE	FS-15/75/2550/1552/1562
CHECKED	Feb 2 1980 K. YAMAGUCHI	名称	デジタルMF/HF送受信装置 (冷却ファン付)
APPROVED	Feb 2 1980 J. YAMAGUCHI	外寸図	
SCALE	1/5	NAME	SSB TRANSCEIVER W/ HANGER & FAN KIT
MASS	± 10%	OUTLINE DRAWING	
DWG. No.	C5573-G02-E		

3 4 5 6

寸法区分 (m.m) DIMENSIONS	公差 (m.m) TOLERANCE
0 < L ≤ 50	±1.5
50 < L ≤ 100	±2.5
100 < L ≤ 500	±3

表 1 TABLE 1

- 注 記
- 1) #印寸法は最小サービス空間寸法とする。
 - 2) 指定外の寸法公差は表 1 による。
 - 3) 取付用ネジは M6 ボルト、またはコーチボルト呼び径 6 を使用のこと。
 - 4) 装備ケーブルはサービス時、指示部を前方に十分引き出せるよう余裕を持たせること。

NOTE

1. # RECOMMENDED SERVICE CLEARANCE.
2. TABLE 1 INDICATES TOLERANCE OF DIMENSIONS.
3. USE M6 BOLTS OR COARCH SCREWS #6 FOR FIXING THE UNIT.
4. KEEP SUFFICIENT CABLE LENGTH BEHIND THE UNIT.

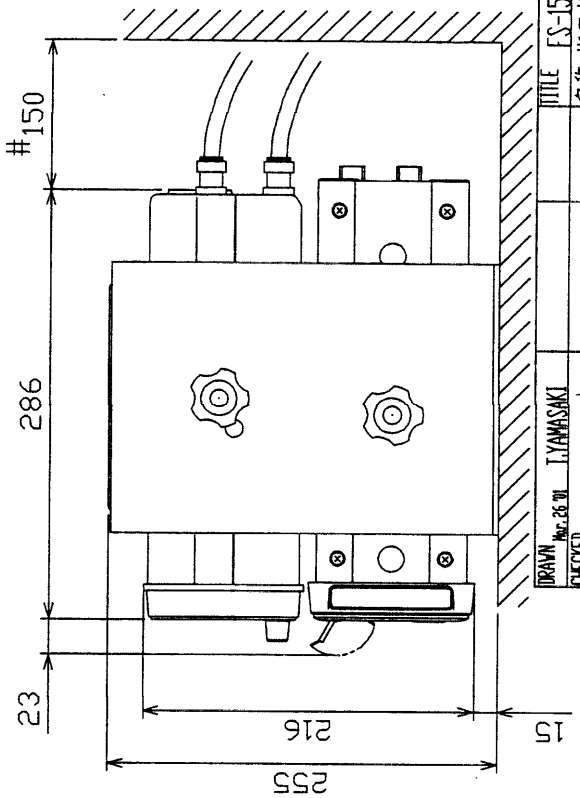
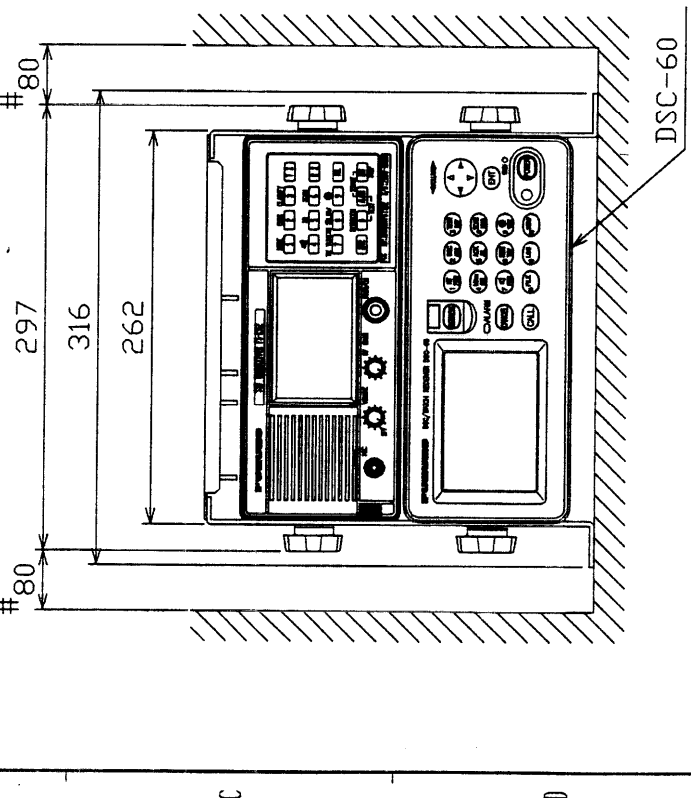
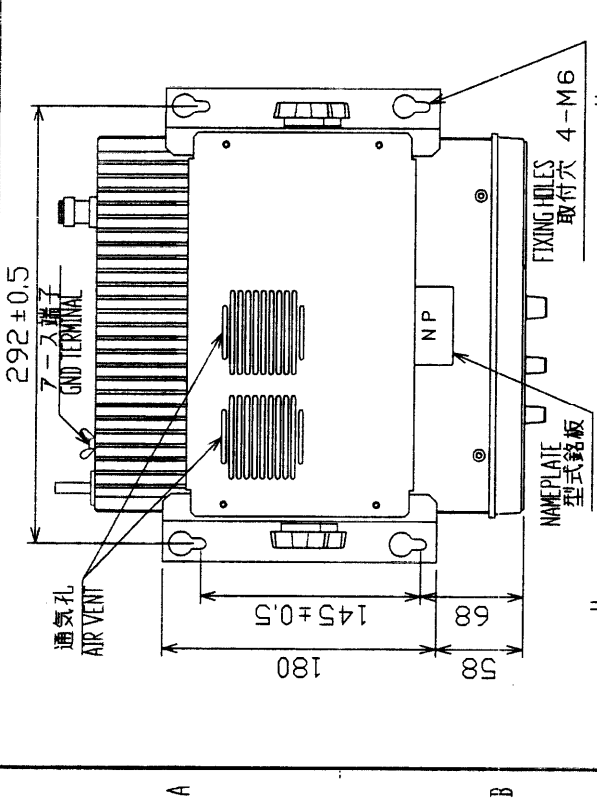

DRAWN	Mr. T. YAMASHAKI	TITLE	FS-1562
CHECKED	Y. K.	名称	指示部 (二段ハンガー)
APPROVED	Y. K.	外寸図	
SCALE	1/5	NAME	DISPLAY UNIT W/ HANGER
DWG No.	C5573-003-A		OUTLINE DRAWING
			05-062-330G-0

表 1 TABLE 1

寸法区分 (mm) DIMENSION	公差 (mm) TOLERANCE
0 < L ≤ 50	±1.5
50 < L ≤ 100	±2.5
100 < L ≤ 500	±3

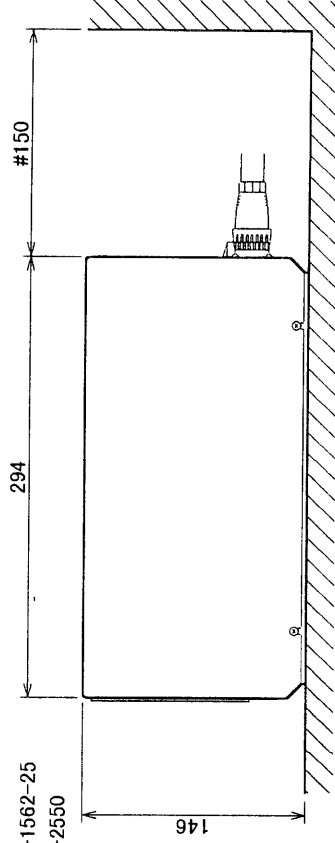
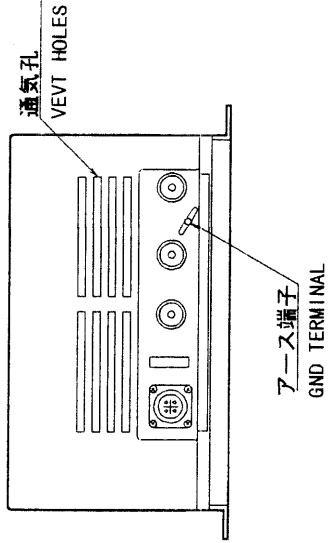

FOR PA-2500J ONLY
PA-2500Jのみ

PA-2500 - FS-1562-25
PA-2500J - FS-2550

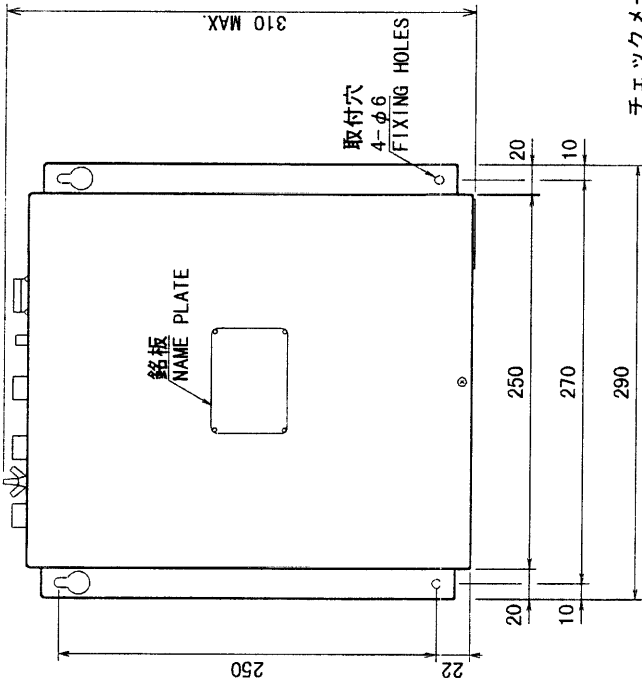

チェックメータ
CHECK METER

切替スイッチ
SWITCH

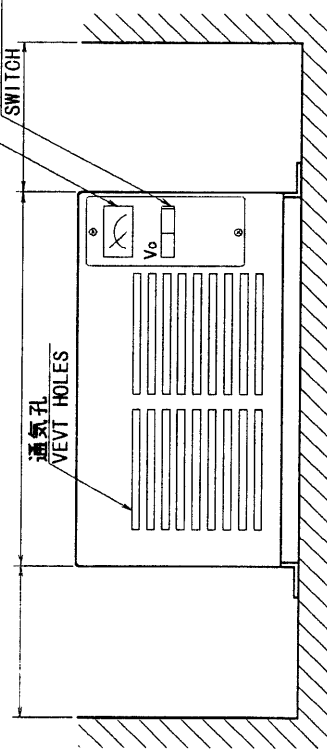

注記

- 1) 指定なき寸法公差は表 1 による。
- 2) 取付には+トラスタッピングネジ呼び径5x20を使用のこと。

NOTE

1. TABLE 1 INDICATES TOLERANCE OF DIMENSIONS.
2. USE TAPPING SCREWS 5x20 FOR INSTALLATION.

DRAWN <i>Shigeo Ito</i>	TITLE PA-2500, PA-2500J
CHECKED <i>Shigeo Ito</i>	名称 パワーブースター
APPROVED <i>Y. Kawai</i>	外寸図
SCALE 1/5	NAME POWER BOOSTER
MASS ±10% 6 kg	OUTLINE DRAWING
DWG. No. C5596-G01-D	

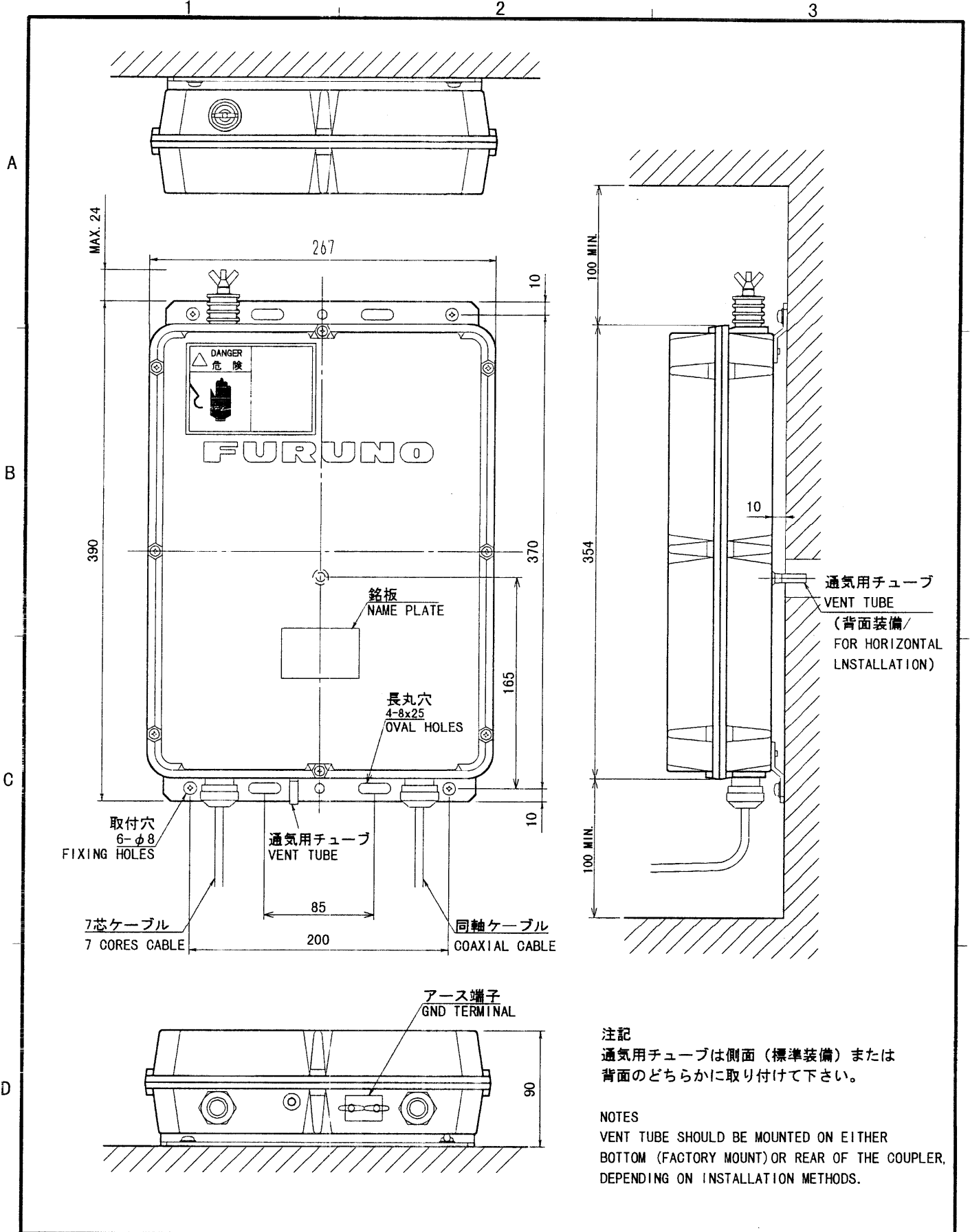

注記
 通気用チューブは側面（標準装備）または背面のどちらかに取り付けて下さい。

NOTES
 VENT TUBE SHOULD BE MOUNTED ON EITHER BOTTOM (FACTORY MOUNT) OR REAR OF THE COUPLER, DEPENDING ON INSTALLATION METHODS.

DRAWN June 26 '00 T. YAMASAKI		TITLE AT-1560, AT-1560-25	
CHECKED June 26 '00 Y. Kina		名称 アンテナカプラー	
APPROVED June 26 '00 Y. Kina		外寸図	
SCALE 1/4	MASS 3.2 kg	NAME ANTTENA COUPLER	
DWG. No. C5574-G01-D		OUTLINE DRAWING	

寸法区分 (mm) DIMENSION	公差 (mm) TOLERANCE
$L \leq 50$	± 1.5
$50 < L \leq 100$	± 2.5
$100 < L \leq 500$	± 3

表 1 TABLE 1

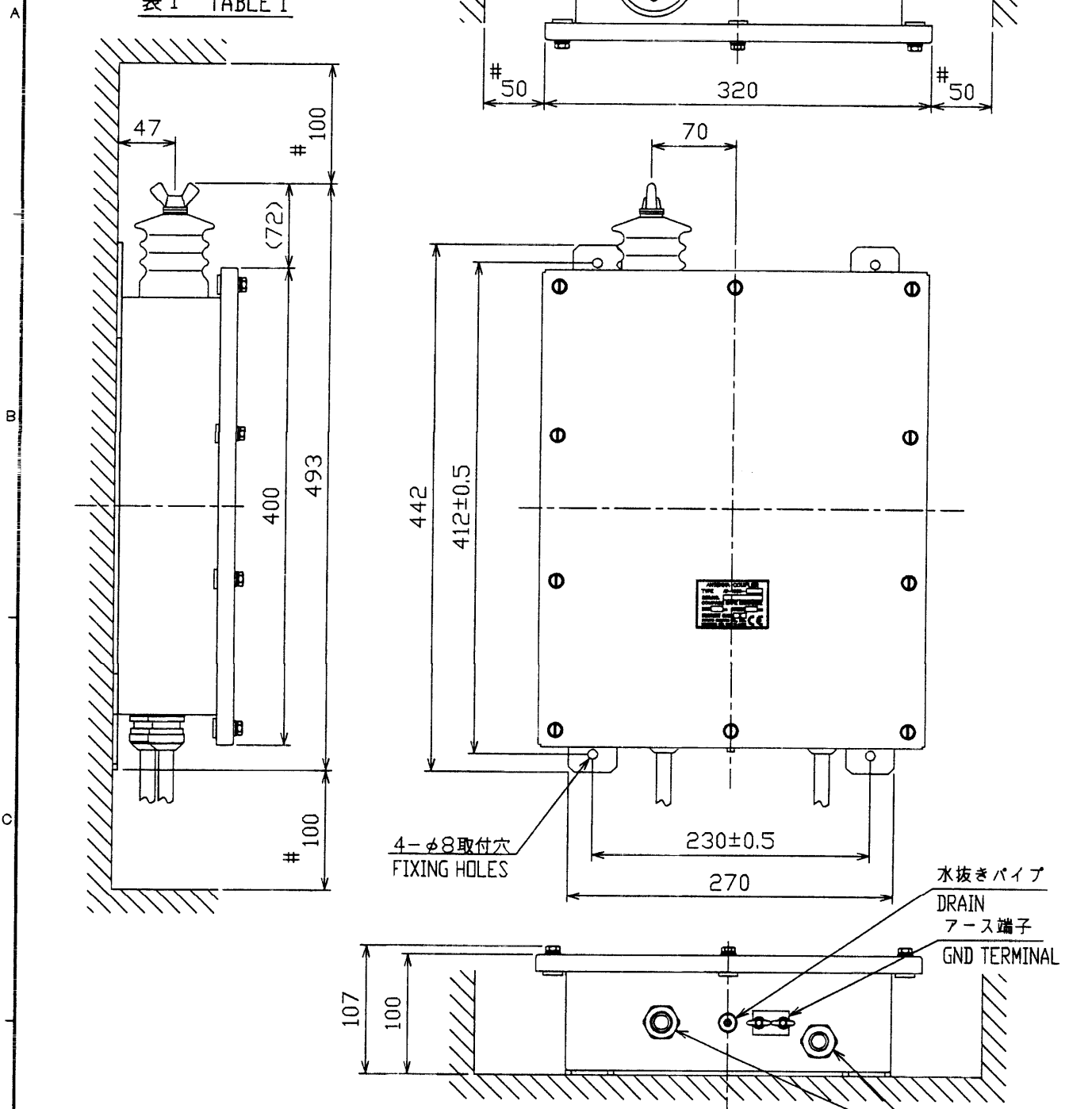

注 記 1) #印寸法は最小サービス空間寸法とする。
2) 指定外の寸法公差は表 1 による。

NOTE 1. # RECOMMENDED SERVICE CLEARANCE.
2. TABLE 1 INDICATES TOLERANCE OF DIMENSIONS.

DRAWN Jul 16 '01 I. YAMASAKI		TITLE AT-1560-15/25-SUS
CHECKED Jul 16 '01 Y. K.		名称 アンテナカプラー
APPROVED Jul 16 '01 Y. K.	FS-1562-15/25	外寸図
SCALE 1/5	MASS 8.7 ±10% kg	NAME ANTENNA COUPLER
DWG.No. C5572-G03-A	05-029-030G-2	OUTLINE DRAWING

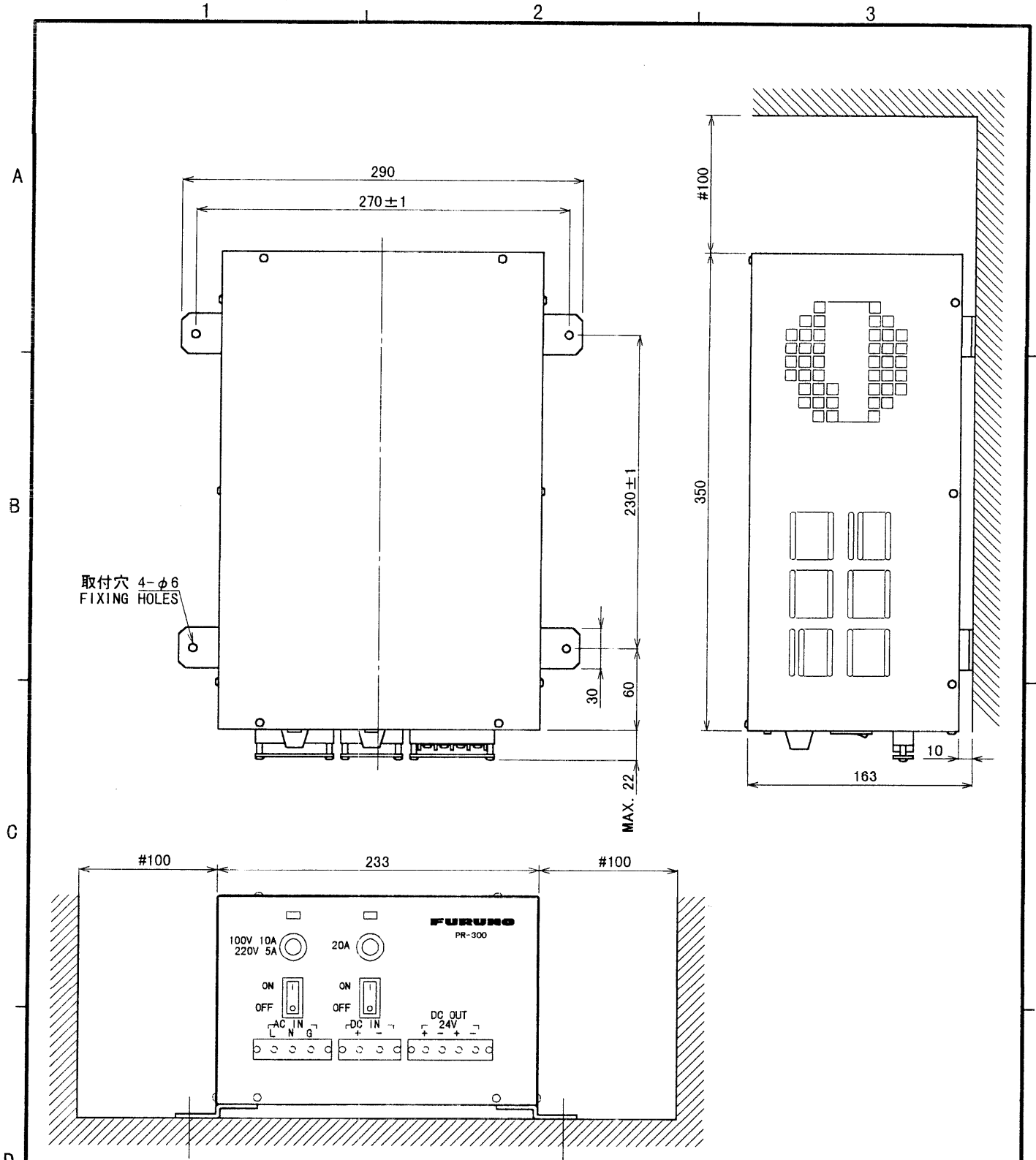

注記
 1) # : 推奨する最小サービス空間寸法。
 2) 指定なき寸法公差は表 1 による。

NOTE:
 1. #: RECOMMENDED SERVICE CLEARANCE.
 2. TABLE 1 INDICATES TOLERANCE OF DIMENSIONS.

表 1 TABLE 1

寸法範囲 (mm) DIMENSION	公差 (mm) TOLERANCE
0 < L ≤ 50	±1.5 mm
50 < L ≤ 100	±2.5 mm
100 < L ≤ 500	±3 mm

DRAWN <i>June. 19 '00 T. Yamasaki</i>		TITLE PR-300
CHECKED <i>June 19 '00 Y. Kimura</i>		名称 AC-DC電源ユニット
APPROVED <i>June 19 '00 T. Kimura</i>		外寸図
SCALE 1/4 MASS ±10% 14.5 kg		NAME AC-DC POWER SUPPLY UNIT
DWG. No. C5003-G02- D		OUTLINE DRAWING

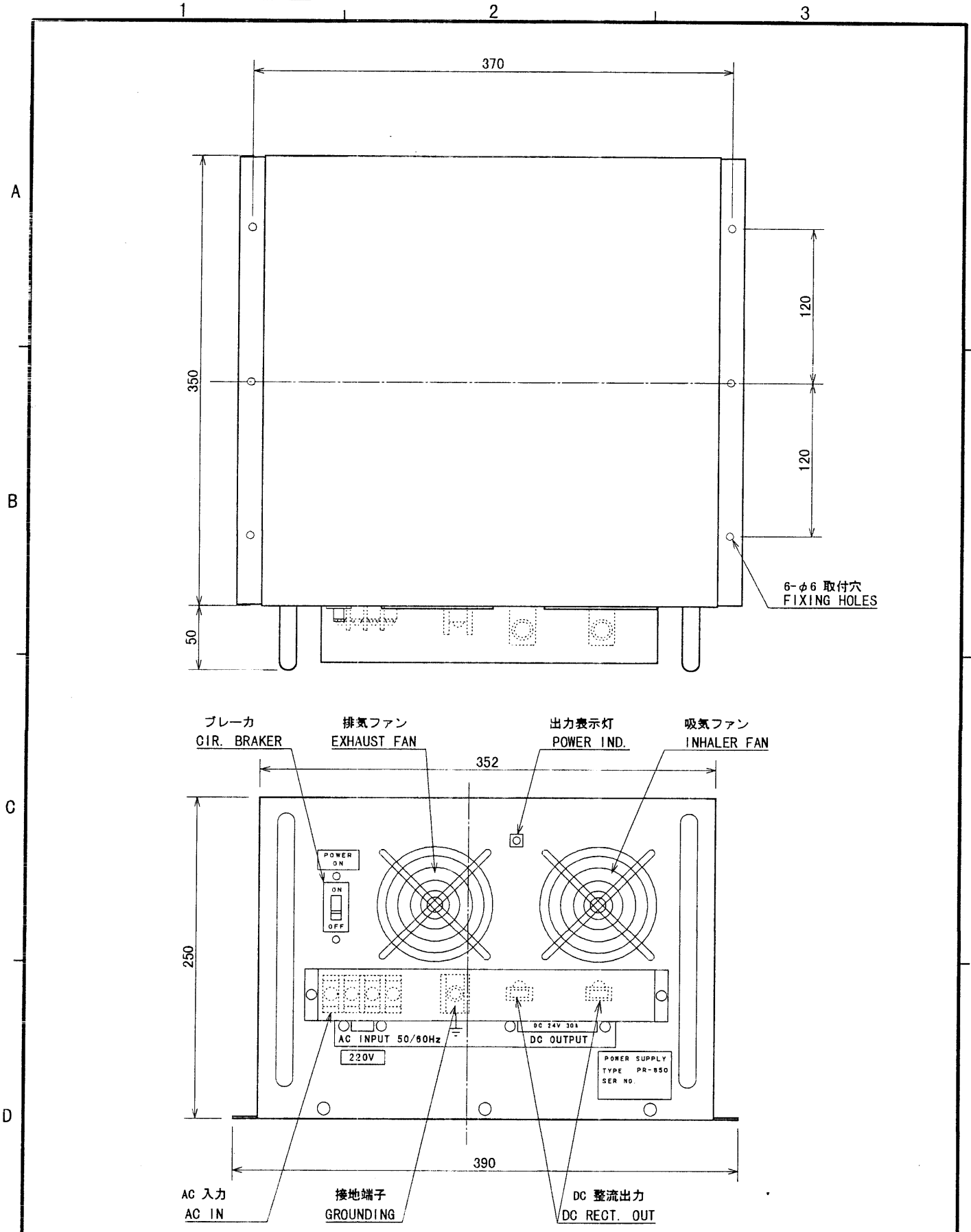

DRAWN June 27'00 T. YAMASAKI		TITLE PR-850
CHECKED June 27'00 Y. KIMURA		名称 AC電源ユニット
APPROVED June 27'00 Y. KIMURA		外寸図
SCALE 1/4 MASS 35 kg		NAME AC POWER SUPPLY UNIT
DWG. No. C5519-G04-C		OUTLINE DRAWING

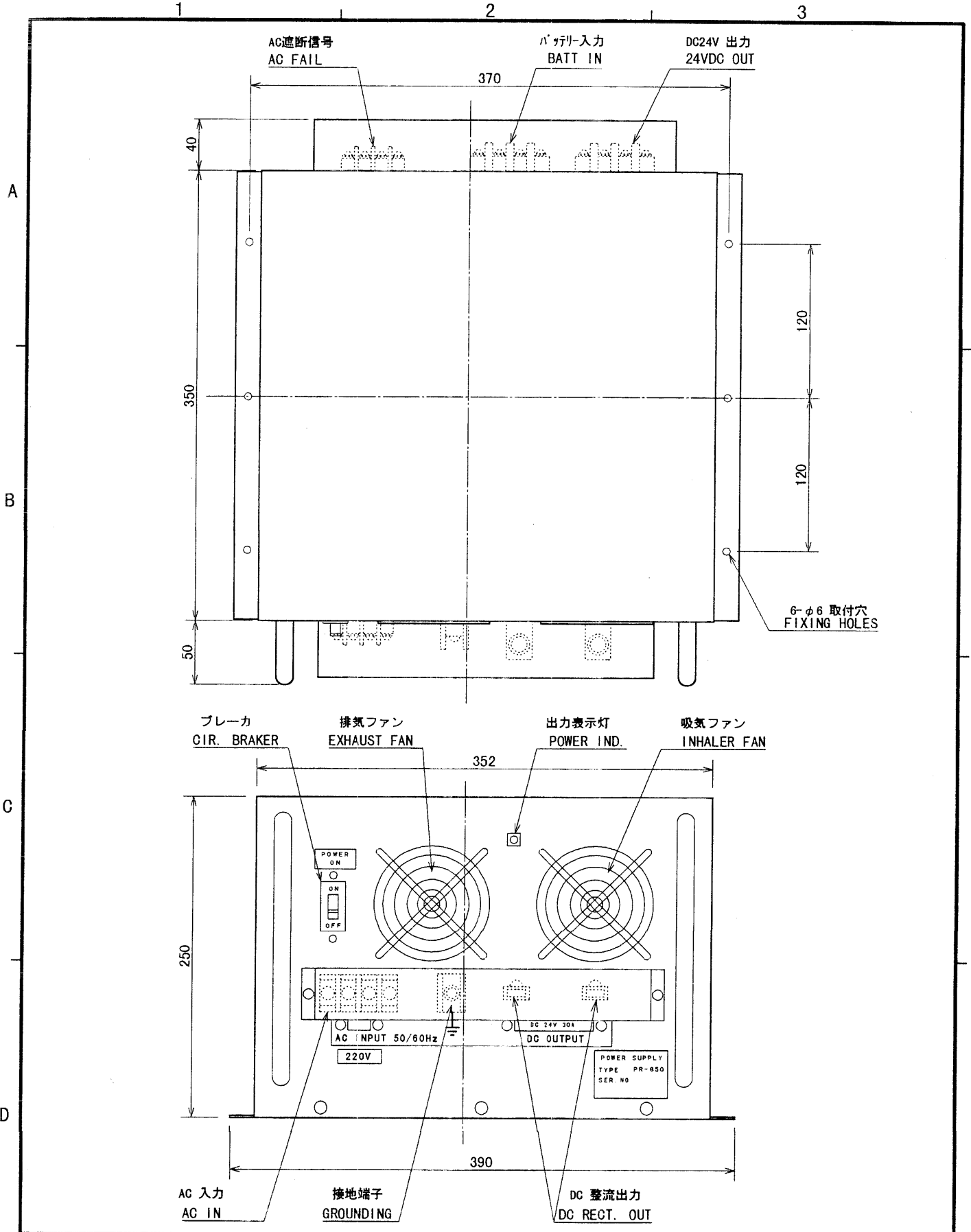

DRAWN June 27 '00 T. YAMASAKI		TITLE PR-850A	
CHECKED June 27 '00 W. Y. Kuroi		名称 AC-DC電源ユニット	
APPROVED June 27 '00 W. Y. Kuroi		外寸図	
SCALE 1/4	MASS 35 kg	NAME AC-DC POWER SUPPLY UNIT	
DWG. No. C5519-G11-E		OUTLINE DRAWING	

表 1 TABLE 1

寸法区分 (mm) DIMENSION	公差 (mm) TOLERANCE
$0 < L \leq 50$	± 1.5
$50 < L \leq 100$	± 2.5
$100 < L \leq 500$	± 3

A

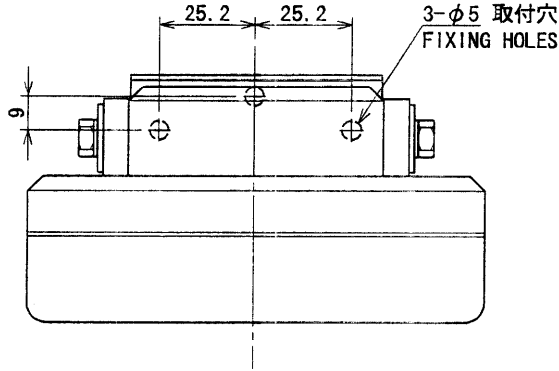

B

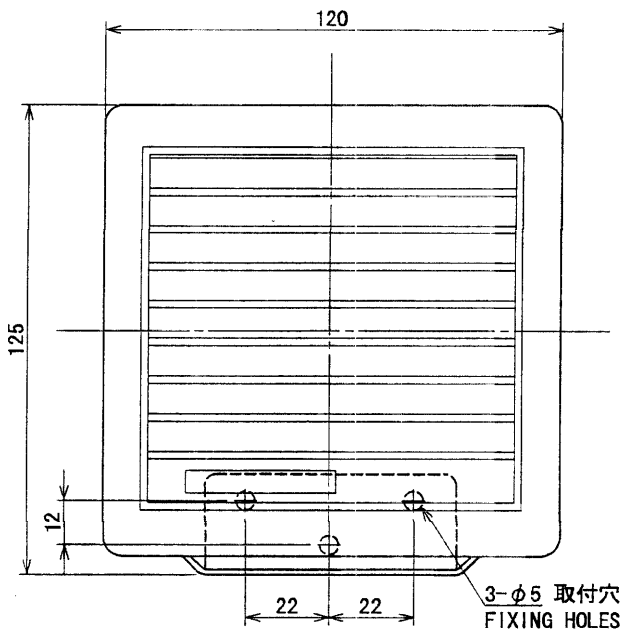

C

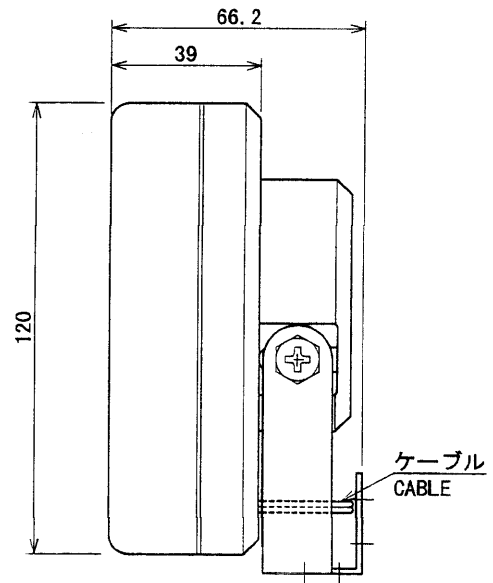

D

注記

1) 指定なき寸法公差は表 1 による。

NOTE

1. TABLE 1 INDICATES TOLERANCE OF DIMENSIONS.

DRAWN May 23 '01 T. YAMASAKI		TITLE SEM-21Q
CHECKED <i>Miyazaki T. K.</i>		名称 スピーカ
APPROVED <i>Miyazaki T. K.</i>		外寸図
SCALE 1/2	MASS ±10% 0.54 kg	NAME LOUDSPEAKER
DWG. No. C5016-G07- A	質量は2.8mケーブルを含む MASS W/ 2.8m CABLE	OUTLINE DRAWING

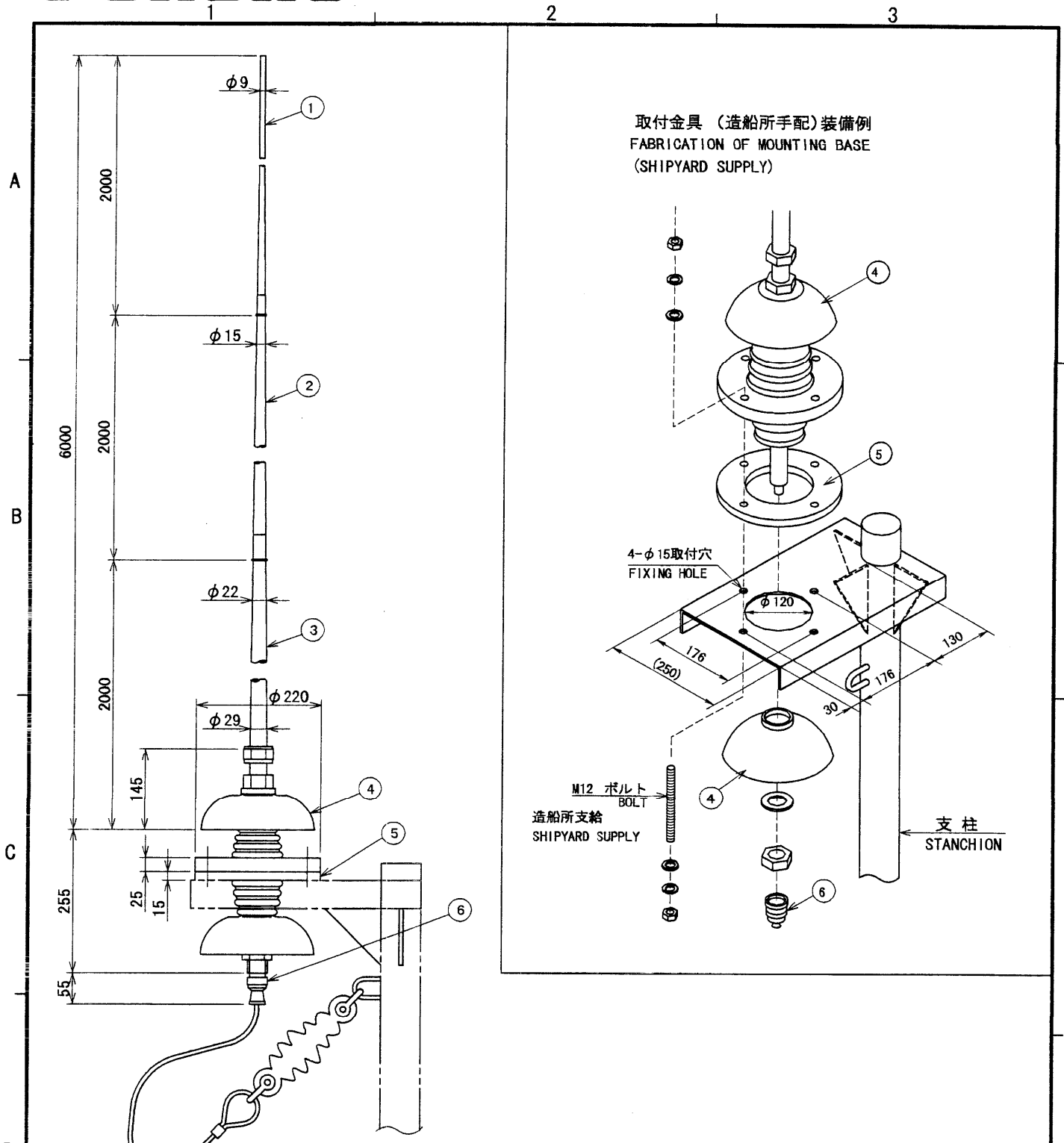

6	ケーブル保護金具 CABLE COVER	BRASS	1		
5	パッキン GASKET	CR	1		φ220x15t
4	碍子 INSULATOR	RESIN	1		
3	基部素子 BASE ELEMENT	FIBERGLASS	1		
2	継素子 MIDDLE ELEMENT	FIBERGLASS	1		
1	上部素子 TOP ELEMENT	FIBERGLASS	1		
品番 ITEM	品名 NAME	材質 MATERIAL	数量 QTY	図番 DWG No.	摘要 REMARKS

DRAWN Sep 27 '00 TAMASAKI	TITLE FAW-6D
CHECKED Sep 27 '00 Y. Kuroki	名称 6 m ホイップアンテナ
APPROVED Sep 27 '00 Y. Kuroki	外寸図
SCALE 1/10	NAME 6 m WHIP ANTENNA
MASS 10 ±10% kg	OUTLINE DRAWING
DWG. No. C5011-034-B	

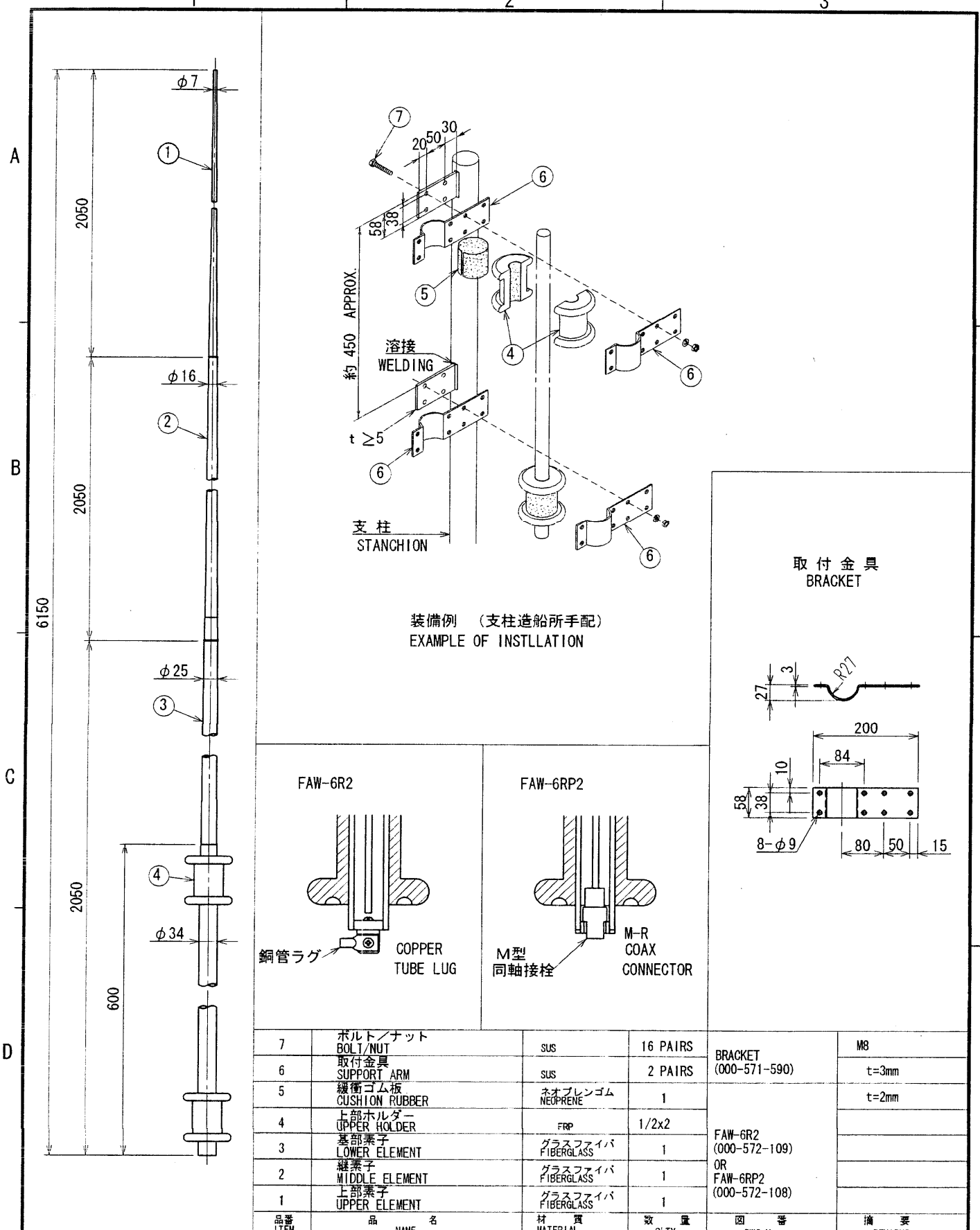

裝備例 (支柱造船所手配)
EXAMPLE OF INSTLLATION

取付金具
BRACKET

FAW-6R2

FAW-6RP2

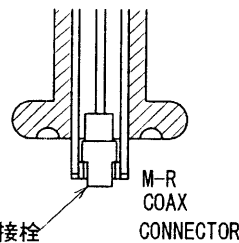
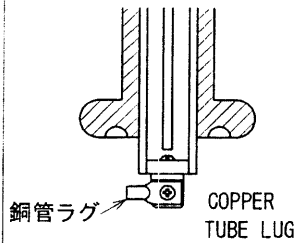

品番 ITEM	品名 NAME	材質 MATERIAL	数量 Q'TY	図番 DWG. No.	摘要 REMARKS
7	ボルト/ナット BOLT/NUT	SUS	16 PAIRS	BRACKET (000-571-590)	M8
6	取付金具 SUPPORT ARM	SUS	2 PAIRS		t=3mm
5	緩衝ゴム板 CUSHION RUBBER	ネオプレンゴム NEOPRENE	1	FAW-6R2 (000-572-109) OR FAW-6RP2 (000-572-108)	t=2mm
4	上部ホルダー UPPER HOLDER	FRP	1/2x2		
3	基部素子 LOWER ELEMENT	グラスファイバ FIBERGLASS	1		
2	継素子 MIDDLE ELEMENT	グラスファイバ FIBERGLASS	1		
1	上部素子 UPPER ELEMENT	グラスファイバ FIBERGLASS	1		

DRAWN 2006.27'00 T.YAMASAKI CHECKED 2007.10.05 Y.K APPROVED 2007.10.05 Y.K SCALE 1/10 MASS ±10% ELEMENT: 3 kg DWG. No. C5011-038- D	TITLE FAW-6R2/6RP2 名称 ホイップアンテナ 外寸図 NAME WHIP ANTENNA OUTLINE DRAWING
--	---

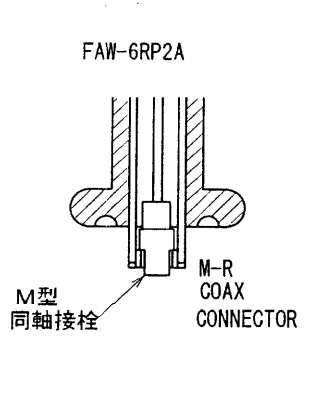
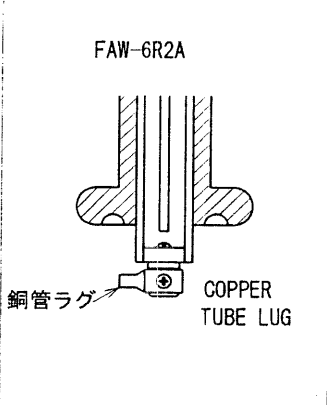
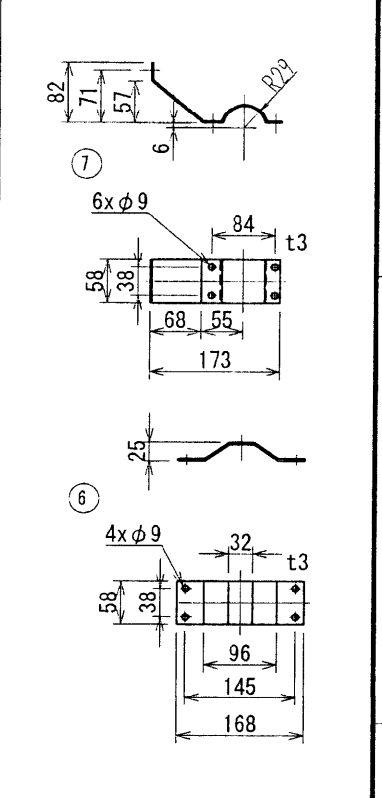
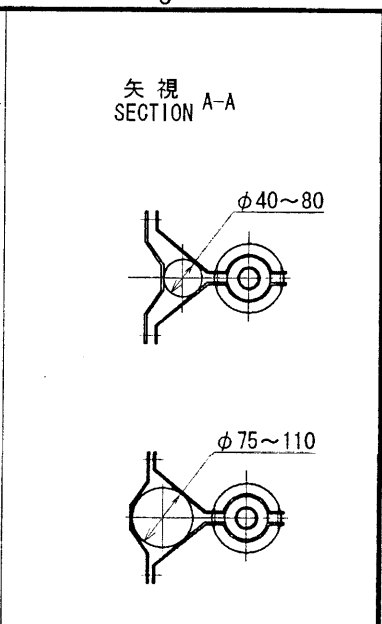
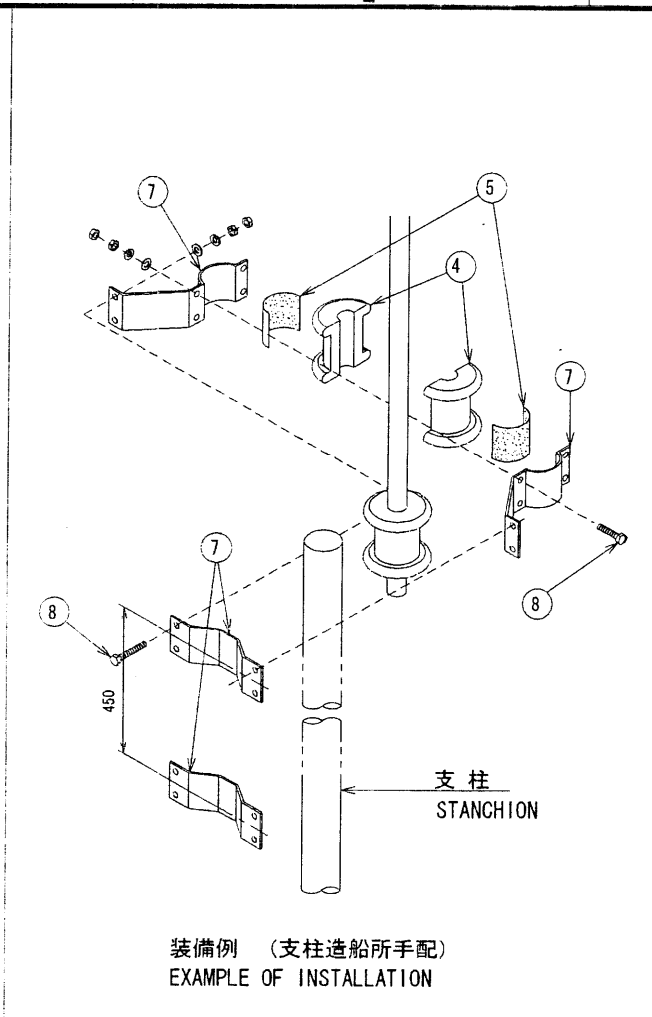
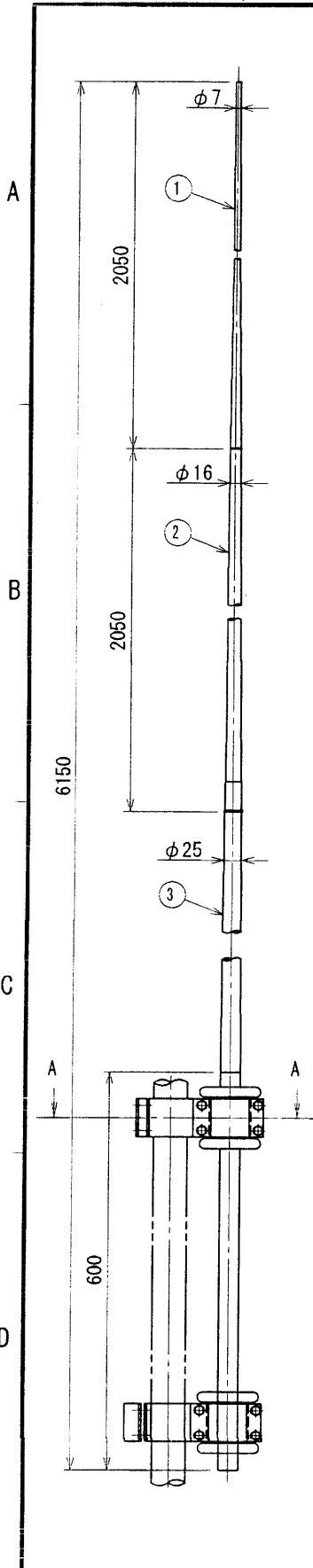

品番 ITEM	品名 NAME	材質 MATERIAL	数量 Q'TY	図番 DWG. No.	摘要 REMARKS
8	ボルト/ナット BOLT/NUT	SUS305	8 PAIRS		MBx80 MBx35
7	取付金具 SUPPORT ARM	SUS305	4		t=3mm
6	押え金具 FIXING BRACKET	SUS305	2	AKB-6HA (000-107-691)	t=3mm
5	緩衝ゴム板 CUSHION RUBBER	ネオプレンゴム NEOPREN	1		
4	上部ホルダー UPPER HOLDER	FRP	1/2x2		
3	基部素子 LOWER ELEMENT	グラスファイバ FIBER GLASS	1	FAW-6R2 (000-572-109)	
2	継素子 MIDDLE ELEMENT	グラスファイバ FIBER GLASS	1	OR FAW-6RP2 (000-572-108)	
1	上部素子 UPPER ELEMENT	グラスファイバ FIBER GLASS	1		

DRAWN
S. 27 '00 T. YAMASAKI
CHECKED
APPROVED
SCALE 1/10
MASS ELEMENT: 3 kg
BRACKET: 1 kg

TITLE
名称
外寸図
NAME
WHIP ANTENNA

TITLE
名称
外寸図
NAME
WHIP ANTENNA

TITLE
名称
外寸図
NAME
WHIP ANTENNA

DWG. No. C5011-040-C

OUTLINE DRAWING

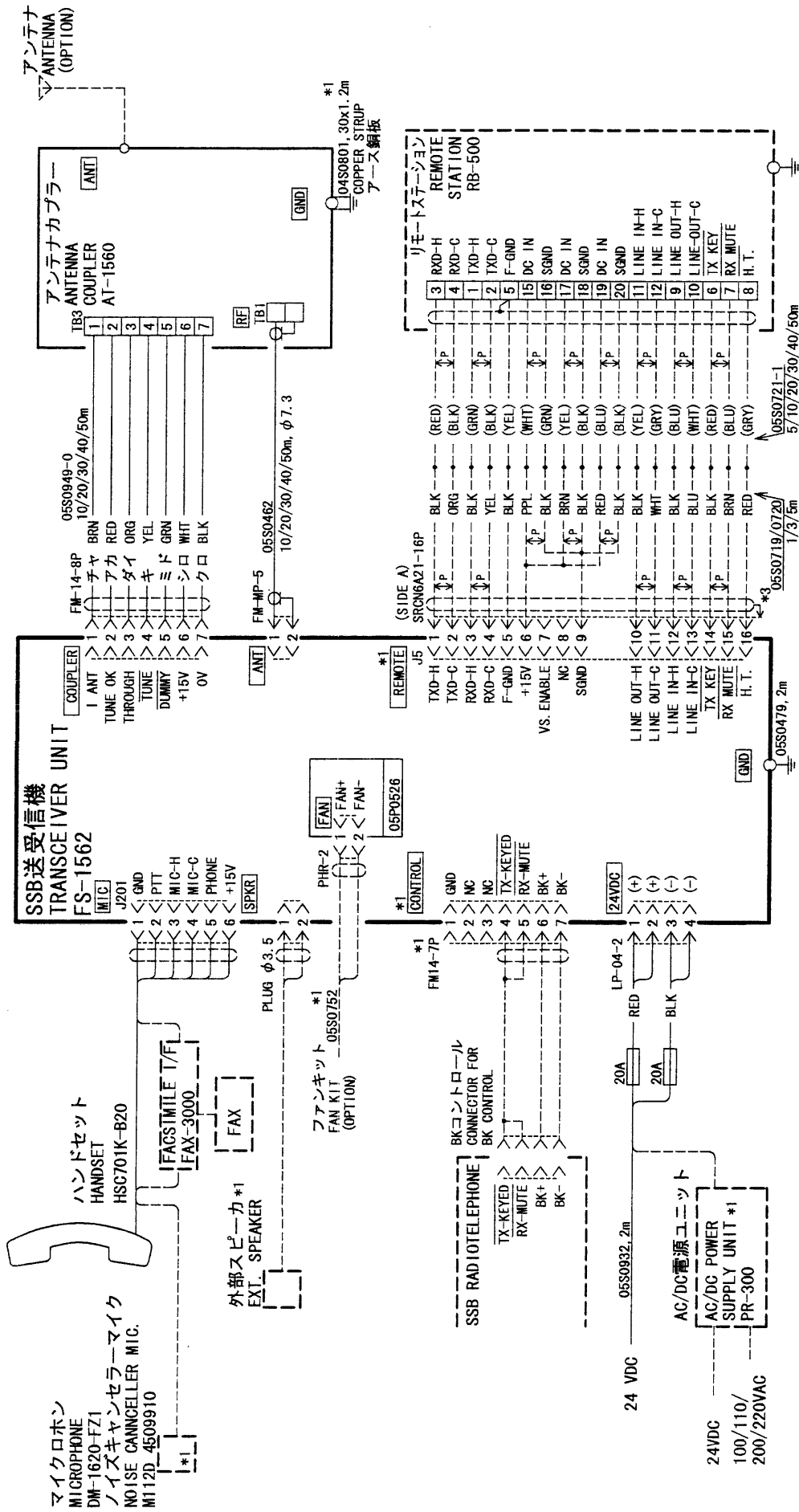

注記

- *1) オプション。
- *2) 造船所手配。
- *3) シールドをコネクタクランプでアースする。

NOTE

- *1. OPTION.
- *2. SHIPYARD SUPPLY.
- *3. GROUND THRU CONNECTOR CLAMP.

DRAWN DATE: 9.01 I. YAMASAKI	TITLE FS-1562
CHECKED AUG 9 '01 Y. K.	名称 SSB 送受信機
APPROVED AUG 9 '01 Y. K.	相互結線図
SCALE 1/3	NAME RADIO TELEPHONE
DWG. No. C5572-C01-H	INTERCONNECTION DIAGRAM

4

3

2

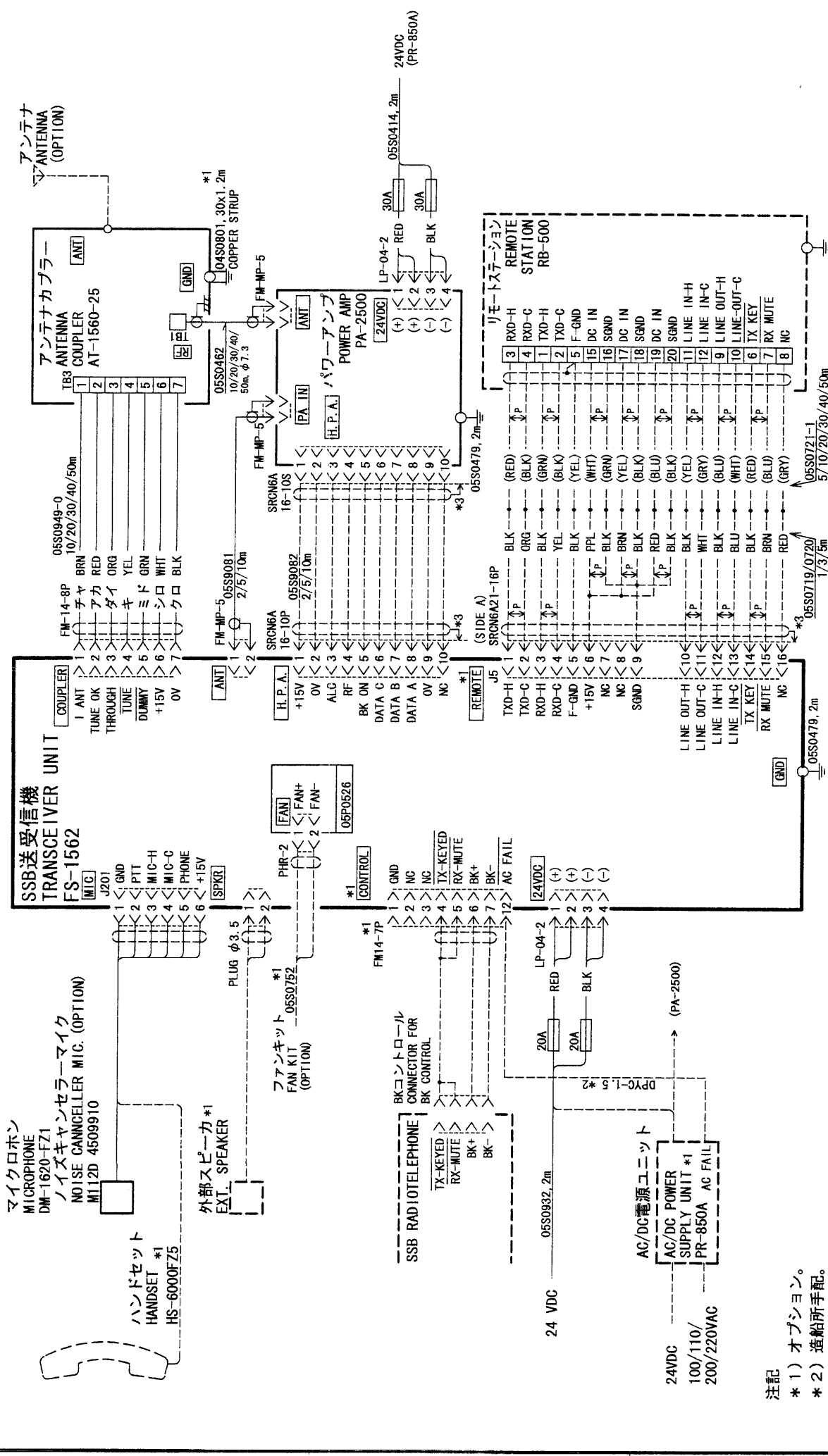

注記
 *1) オプション。
 *2) 造船所手配。
 *3) シールドをコネクタクランプでアースする。

NOTE
 *1. OPTIONAL SUPPLY.
 *2. SHIPYARD SUPPLY.
 *3. GROUND THRU CONNECTOR CLAMP.

DRAWN AULK. 9.01 I. YAMASAKI	TITLE FS-1562-25
CHECKED AOKI 9.01 Y. K.	名称 SSB 送受信機
APPROVED AOKI 9.01 Y. K.	相互結線図
SCALE 1/3/5m	NAME RADIO TELEPHONE
DWG. No. C5596-C01-D	INTERCONNECTION DIAGRAM

SSB送受信機
RADIO TELEPHONE
FS-1502
FS-75
FS-2550

分配器
DISTRIBUTOR
DB-500
REMOTE 1
TB1

リモートステーション
REMOTE
STATION
RB-500
TB1

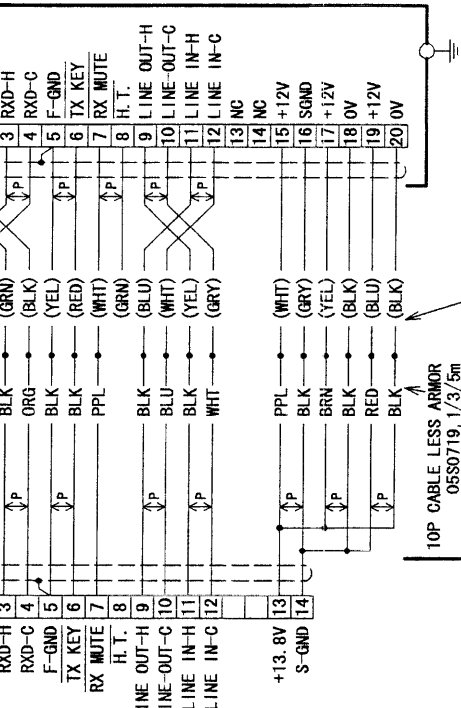
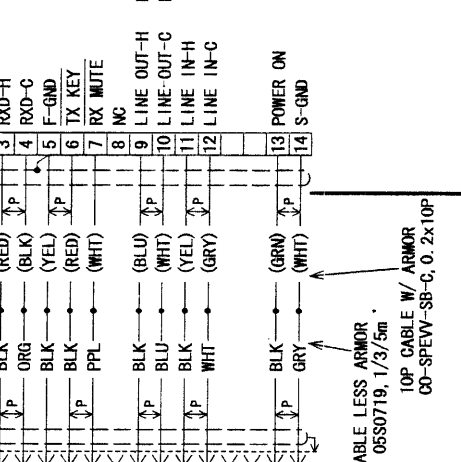
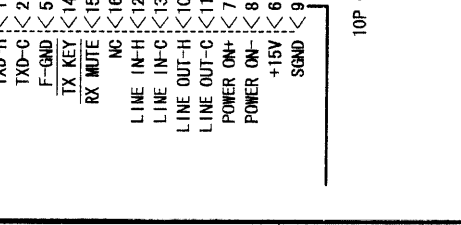

分配器
DISTRIBUTOR
DB-500
REMOTE 2
TB2

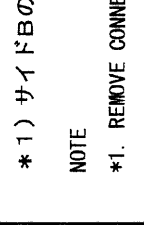
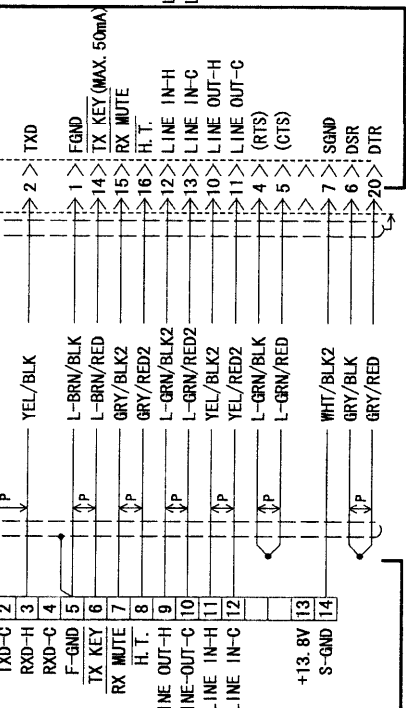
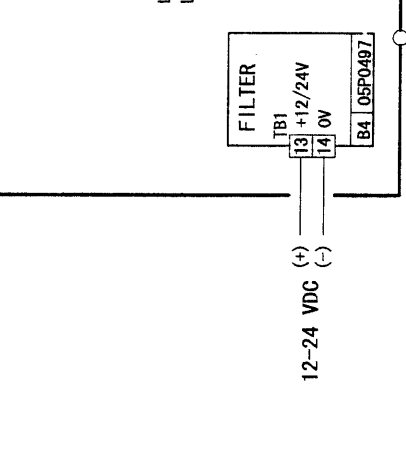
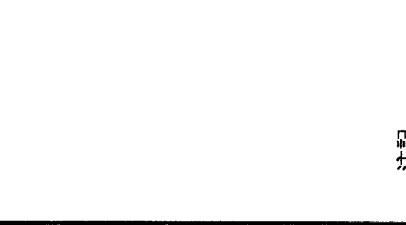
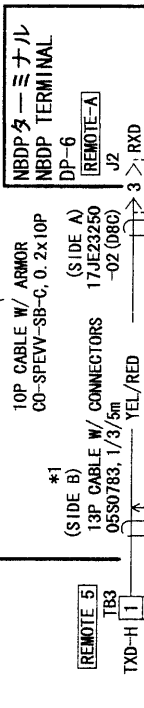
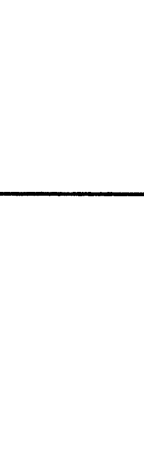

注記
* 1) サイドBのコネクタを取り外す。
NOTE
* 1. REMOVE CONNECTOR PLUG AT SIDE B.

DRAWN	9. '01 T. YAMASAKI
CHECKED	Alexander Yk
APPROVED	Alexander Yk
SCALE	1/100
DWG No.	C5596-002-A
TITLE	FS-1562/75/2550 + DB-500
名称	SSB送受信機
相互結線図	
NAME	SSB RADIO TELEPHONE
INTERCONNECTION DIAGRAM	

2 3 4

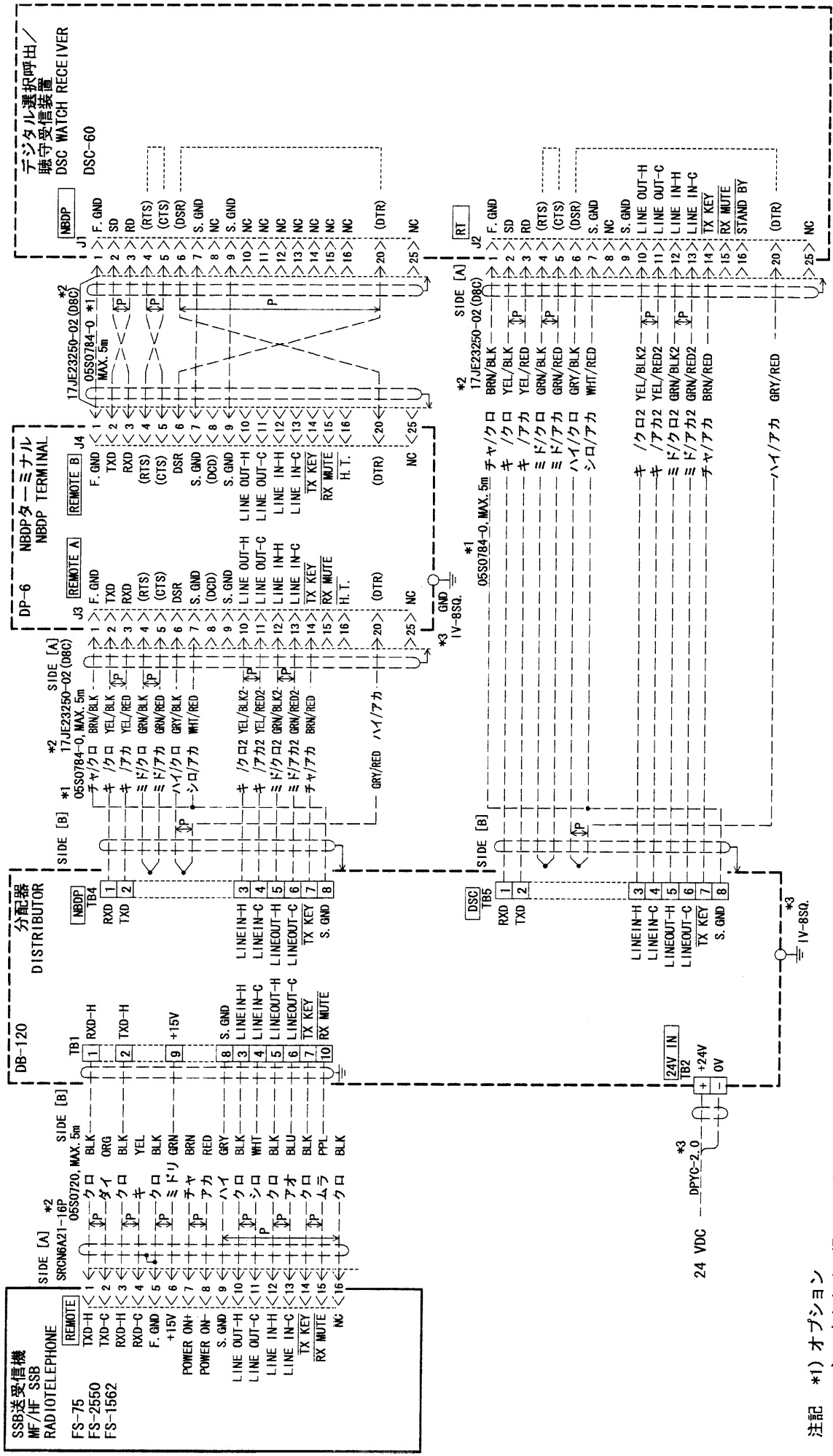

DRAWN Aug. 8 '01 T. YAMASAKI	TITLE DSC-60 (REMOTE)
CHECKED H. K.	名称 デジタル選択呼出/聴守受信装置
APPROVED H. K.	相互結線図
SCALE 1/1	NAME DSC/WATCH RECEIVER
DWG No. C5628-C06-A	INTERCONNECTION DIAGRAM

注記 *1) オプション
*2) コネクタは工場で取付済み。
*3) 造船所手配。

NOTE *1. OPTION
*2. CONNECTOR PLUGS FITTED AT FACTORY.
*3. SHIPYARD SUPPLY.

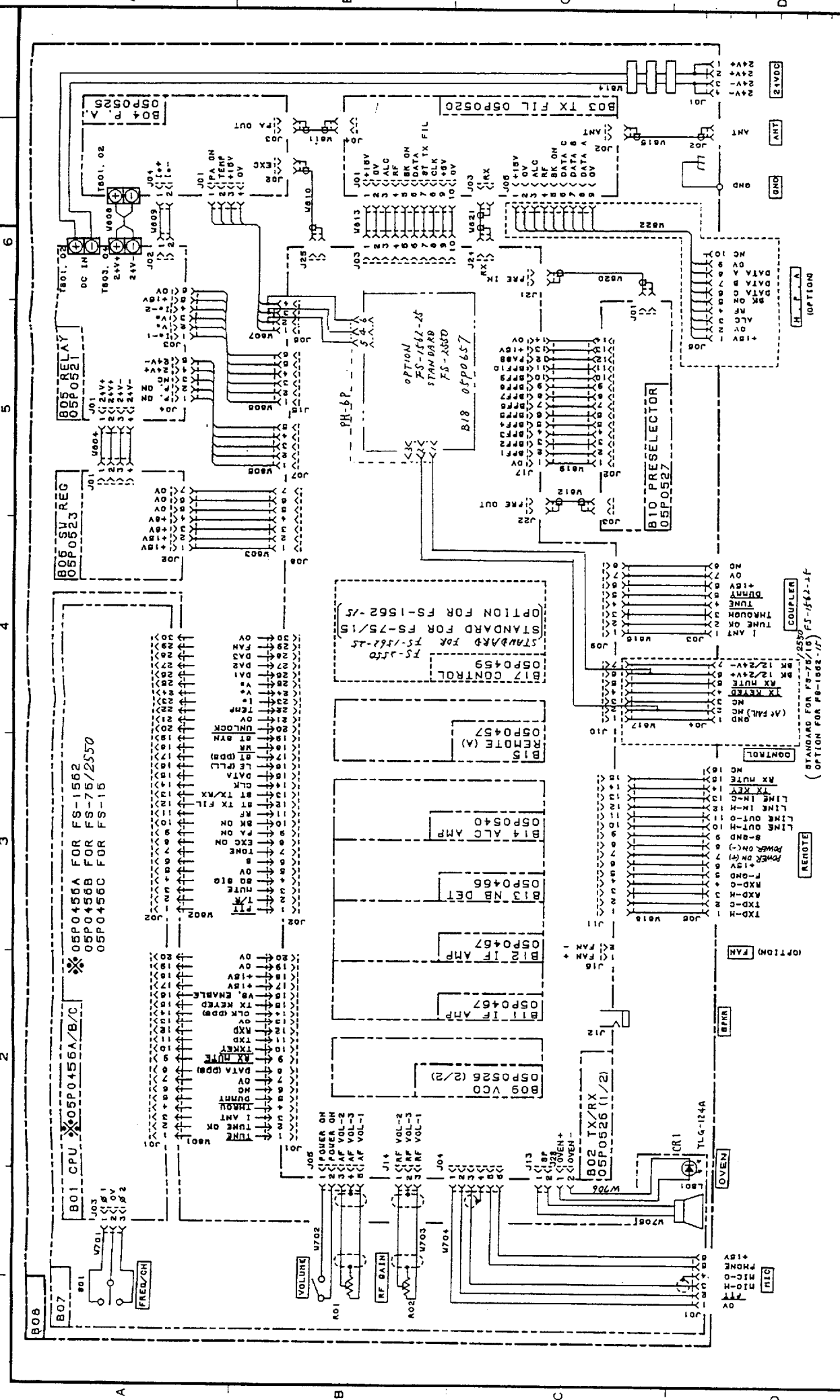

TYPE	CHASSIS
名称	総合 回路図
NAME	GENERAL
BLK NO.	
APPLICABLE TO:	FS-2550 FS-1562 FS-75 FS-15
MODEL:	— KK
DATE:	5572-K10-E
	05-001-3485-3
DRAWN: Aug 20 '77 T. MATSUKI CHECKED: Aug 20 '77 K. KAWANOBUKI APPROVED: Aug 20 '77 H. YAMAGUCHI SCALE: 1:1	
STANDARD FOR FS-1562/2550 (OPTION FOR FS-1562/75)	

SCHEMATIC DIAGRAM

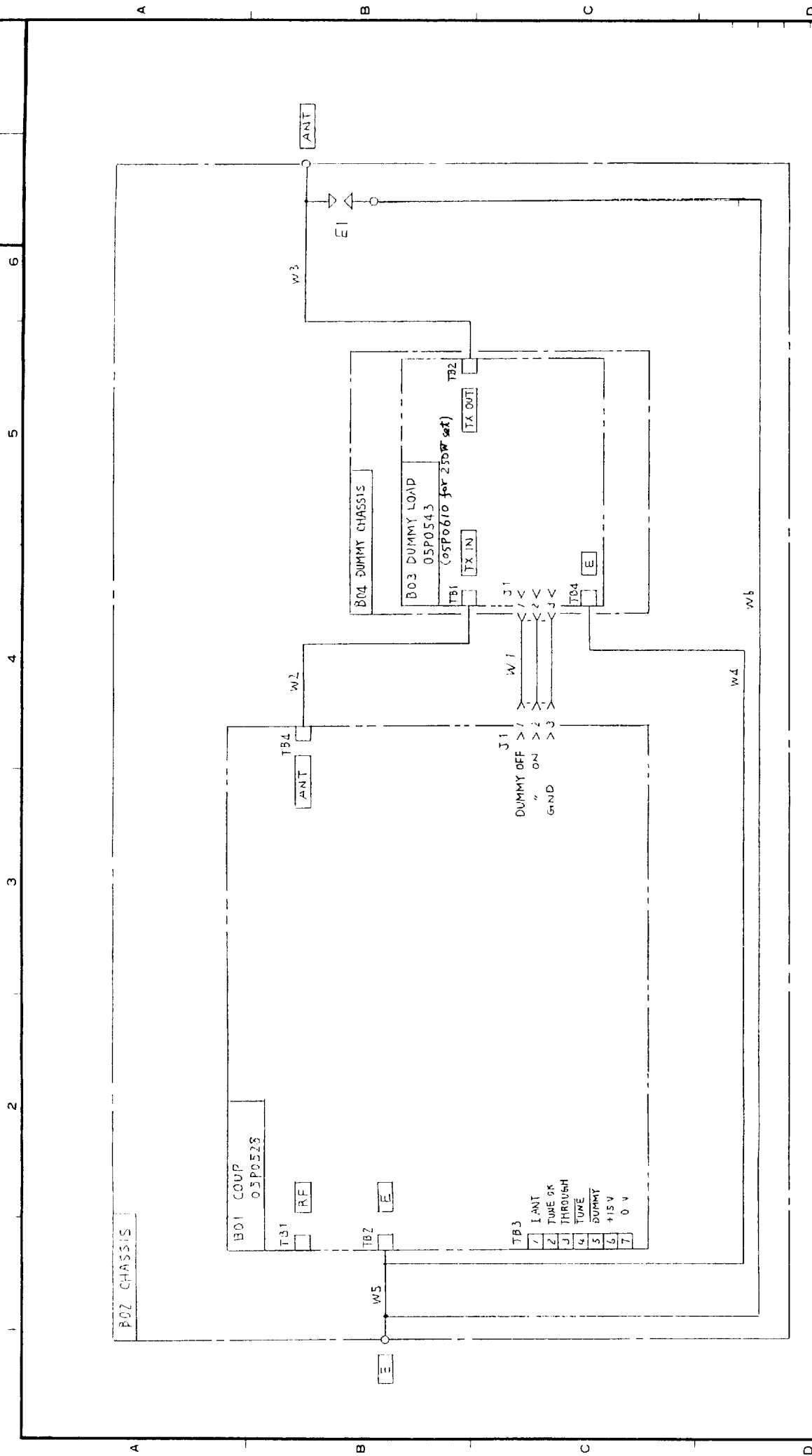

承認 APPROVED	May 31 '83 M. KEDA	名称 TITLE	アンテナカプラー 2B02 AT-1560 ANTENNA COUPLER
検閲 CHECKED	May 31 '83 T. SAITO	製国 DWG. NO.	C5572-K03-B
製図 DRAWN	May 31 '83 T. SAITO		

FS-1562
FS-15/75/2550

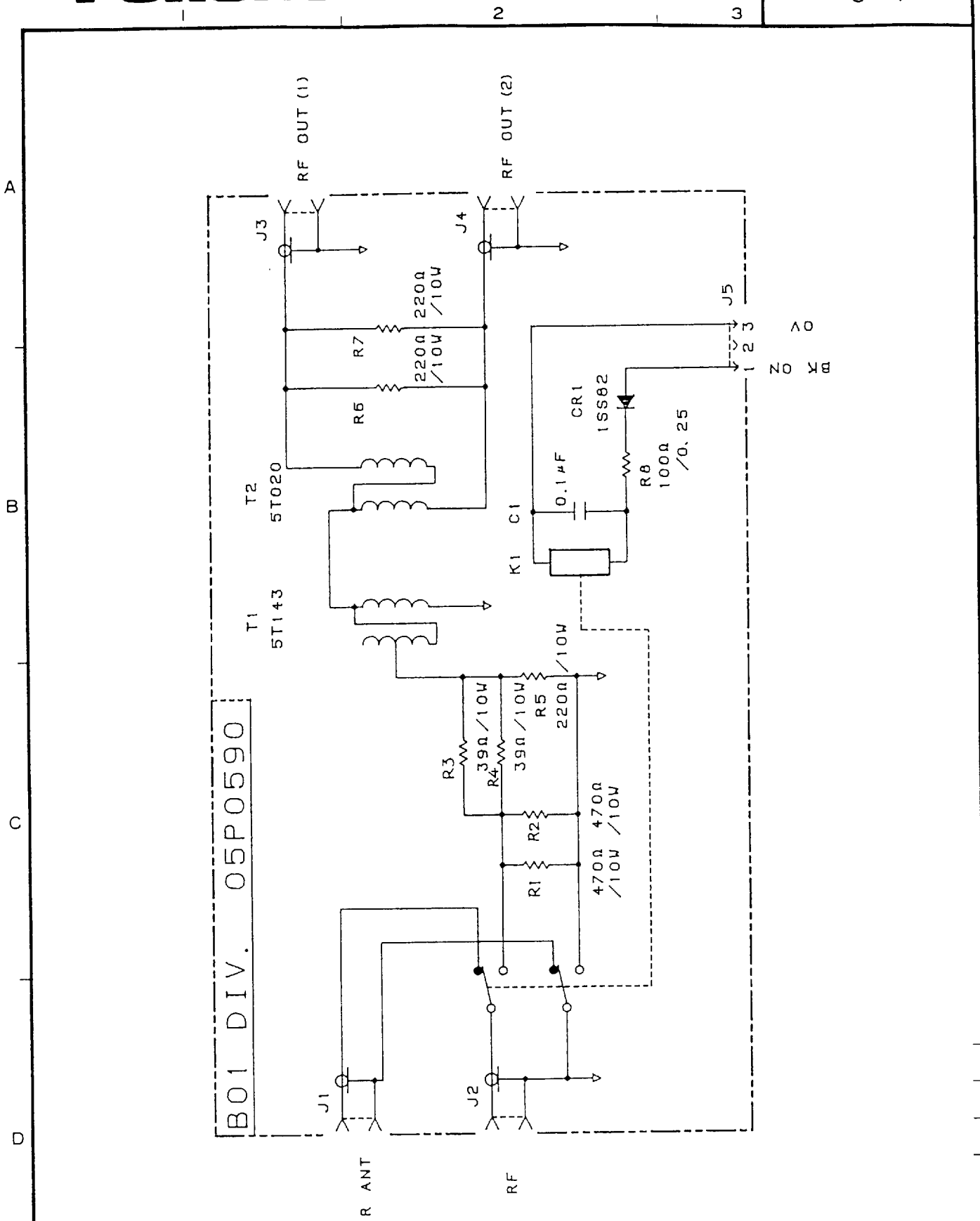

REMARKS				TYPE	05P0590
DRAWN		APPROVED		名称	分配基板
T.Y.		T. SAITO		NAME	DIVIDER BOARD
SCALE	MASS	APPLICABLE TO:	BLOCK NO.	DWG NO.	C5596-K02- B
X	- kg	PA-2500 (MODEL)	B 1		