

Thank you for purchasing the **RMK-2** SEPARATION KIT. The RMK-2 allows you to install the IC-F1700 series transceiver front panel separately from the main unit for added installation convenience and operation. Use either the optional OPC-607, OPC-608 or OPC-609 SEPARATION CABLE with the RMK-2.

Supplied accessories

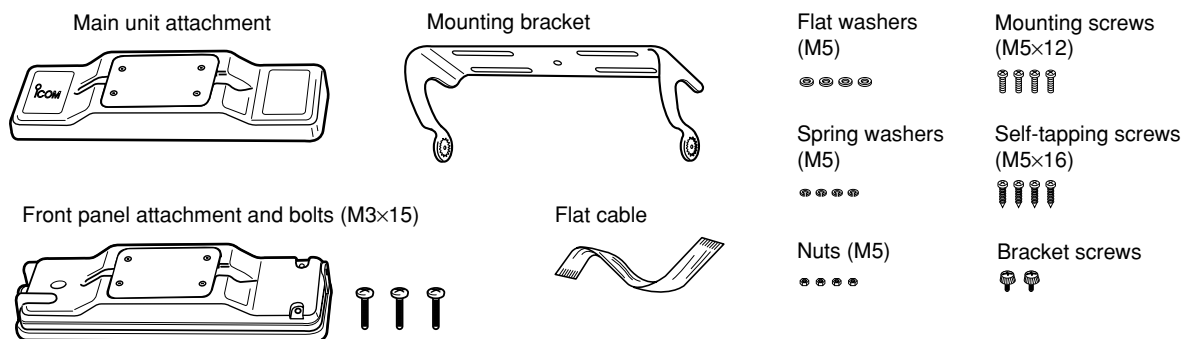

Separation

CAUTION! To avoid damage to the transceiver, turn the power OFF before separating from the main unit.

The optional OPC-607 (3 m; 9.84 ft), OPC-608 (8 m; 26.3 ft) or OPC-609* (1.9 m; 6.3 ft) SEPARATION CABLE is required for installing the transceiver front panel and main unit separately.
*For Europe version, only the OPC-609 is available.

- Turn the transceiver's power OFF, then disconnect the DC power cable.
- Unscrew the 4 bottom screws, then remove the bottom cover from the transceiver in the direction of the arrow.

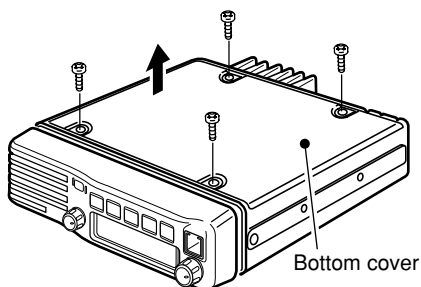

- Disconnect the flat cable and speaker cable* from the main unit.

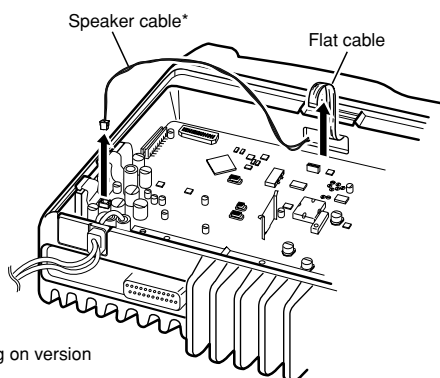

*Depending on version

- Unscrew the 2 side screws, then remove the front panel from the transceiver main unit in the direction of the arrow.

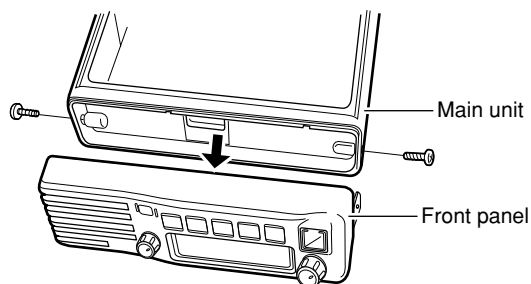

- Unscrew the 4 screws, then remove the rear plates from both the front panel and main unit attachments.

*This illustration shows the description for the front panel attachment.

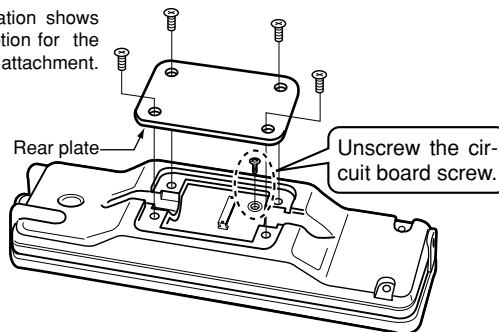

➡ Continue to the back page.

■ Attachment

For the front panel attachment:

- ① Connect the optional OPC-607, OPC-608 or OPC-609 to the front panel attachment as shown below.
After the cable connection, replace the removed rear plate and the 4 screws.
 - The optional cable can be inserted into either the left or right grooves as desired on the back of the attachment.

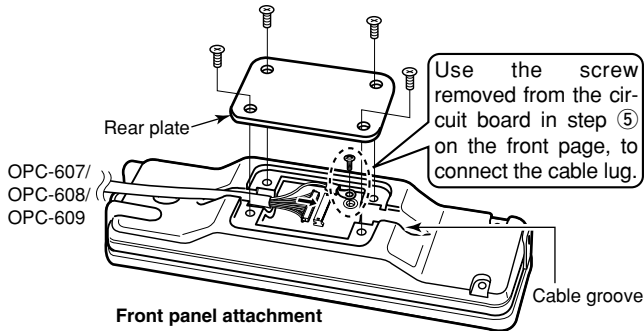

- ② Connect the flat and speaker* cable as shown below.
 - Ensure the flat cable is inserted correctly, and not upside down.

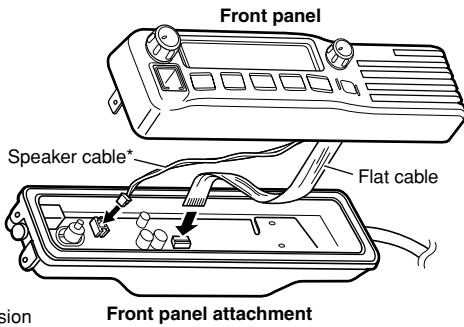

*Depending on version

- ③ Screw the 3 supplied bolts to attach the front panel and the attachment.

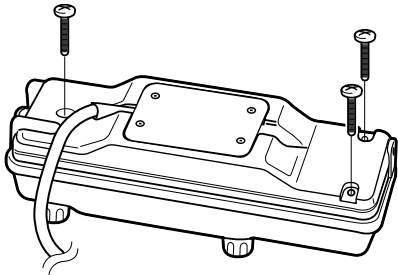

For the main unit attachment:

- ④ Connect the optional OPC-607, OPC-608 or OPC-609 to the main unit attachment as shown below.
After the cable connection, replace the removed rear plate.
 - The optional cable can be inserted into either the left or right grooves as desired on the back of the attachment.

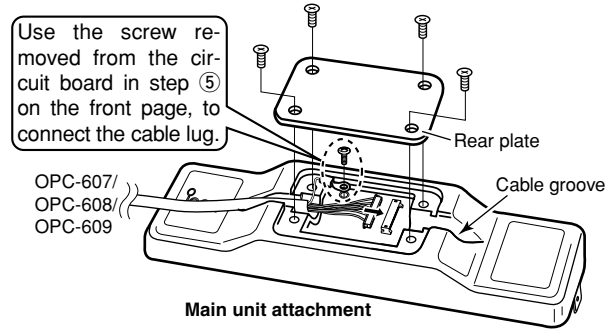

- ⑤ Connect the supplied flat cable* and ground cable (coming from the RMK-2) as shown below.
Then use the 2 screws removed from the transceiver to attach the main unit attachment* and the main unit.

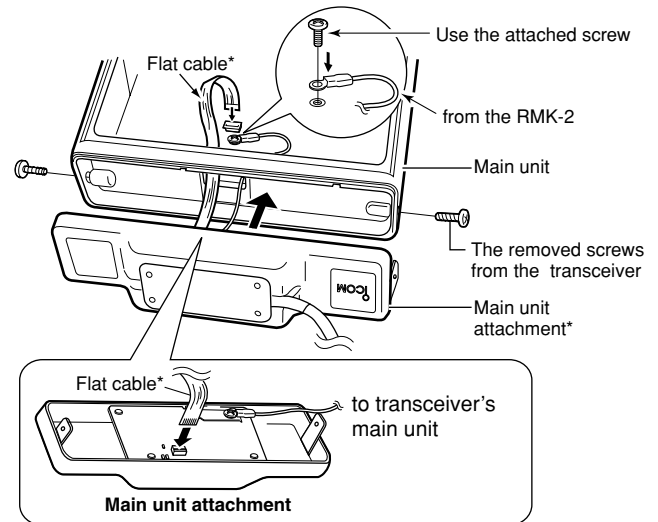

*Ensure the flat cable and attachment are inserted/attached correctly, and not upside down.

- ⑥ Replace the bottom cover and 4 screws removed earlier, then re-connect the DC power cable.

■ Mounting

2 types of mounting styles are available—one is overhead mounting, and other one is on-board mounting. Mount the front panel and the attachment securely with the 4 supplied screws to a thick surface which can support more than 1.5 kg. (Overhead mounting)

On-board mounting

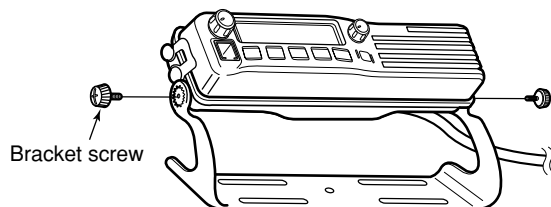

Overhead mounting

