



INSTRUCTION MANUAL

SSB RADIO TELEPHONE
IC-M700PRO



IMPORTANT

READ THIS INSTRUCTION MANUAL CAREFULLY before attempting to operate the transceiver.

SAVE THIS INSTRUCTION MANUAL—This manual contains important safety and operating instructions for the IC-M700PRO SSB RADIO TELEPHONE.

EXPLICIT DEFINITIONS

The explicit definitions described below apply to this instruction manual.

WORD	DEFINITION
⚠ WARNING	Personal injury, fire hazard or electric shock may occur.
CAUTION	Equipment damage may occur.
NOTE	If disregarded, inconvenience only. No risk of personal injury, fire or electric shock.

PRECAUTIONS

⚠ WARNING! NEVER connect the transceiver directly to an AC outlet. This may pose a fire hazard or result in an electric shock.

⚠ WARNING! NEVER mount the transceiver overhead. The weight of the transceiver is approximately 7.9 kg. (17.4 lb), but its apparent weight will increase several fold due to wave shocks and vibration. The transceiver must be mounted on a flat hard surface only.

NEVER connect a power source of more than 16 V DC, such as a 24 volt battery. This connection will ruin the transceiver.

NEVER allow children to play with equipment containing a radio transmitter.

NEVER expose the transceiver to rain, snow or any liquids.

NEVER install the IC-M700PRO into a positive-grounding ship. Such a connection might blow fuses, and is not usable.

DO NOT use chemical agents such as benzene or alcohol when cleaning, as they can damage the transceiver's surfaces.

DISPOSAL



The crossed-out wheeled-bin symbol on your product, literature, or packaging reminds you that in the European Union, all electrical and electronic products, batteries, and accumulators (rechargeable batteries) must be taken to designated collection locations at the end of their working life. Do not dispose of these products as unsorted municipal waste. Dispose of them according to the laws in your area.

Icom, Icom Inc. and the Icom logo are registered trademarks of Icom Incorporated (Japan) in Japan, the United States, the United Kingdom, Germany, France, Spain, Russia, Australia, New Zealand, and/or other countries.

In maritime mobile operation, **KEEP** the transceiver and microphone as far away as possible (at least 1 m) from the magnetic navigation compass to prevent erroneous indications.

USE an Icom microphone and/or handset only (supplied or optional). Other brands may have different pin assignments and may damage the transceiver.

DO NOT use or place the transceiver in areas with temperatures below -20°C (-4°F) or above $+60^{\circ}\text{C}$ ($+140^{\circ}\text{F}$).

DO NOT connect the transceiver to a power source using reverse polarity. This connection will not only blow fuses but may also damage the transceiver.

DO NOT place the transceiver in excessively dusty environments, or in direct sunlight.

DO NOT place the transceiver against walls, or putting anything on top of the transceiver. This will obstruct heat dissipation.

Icom is not responsible for the destruction, damage to, or performance of any Icom or non-Icom equipment, if the malfunction is because of:

- Force majeure, including, but not limited to, fires, earthquakes, storms, floods, lightning, other natural disasters, disturbances, riots, war, or radioactive contamination.
- The use of Icom transceivers with any equipment that is not manufactured or approved by Icom.

TABLE OF CONTENTS

IMPORTANT	i	6 CONNECTIONS AND INSTALLATION.....	15
PRECAUTIONS.....	i	■ Connections on the rear panel	15
EXPLICIT DEFINITIONS.....	i	■ Unpacking.....	15
DISPOSAL.....	i	■ Connector information	16
TABLE OF CONTENTS	ii	■ Ground connection	18
1 OPERATING RULES AND GUIDELINES	1	■ Power source.....	18
2 PANEL DESCRIPTION	2	■ Antenna	19
■ Front panel	2	◇ MN-100/MN-100L ANTENNA MATCHERS	19
■ Display.....	4	◇ AT-130 AUTOMATIC ANTENNA TUNER ...	19
3 SELECTING A CHANNEL/FREQUENCY	5	◇ Non-Icom tuner.....	19
■ Memory mode/VFO mode	5	■ Mounting.....	20
■ Selecting a channel	5	◇ Mounting location	20
◇ Scan function.....	6	◇ Mounting example	20
■ Selecting a frequency	6	◇ Transceiver dimensions.....	20
■ Resetting the CPU	7	■ Disassembling the transceiver.....	21
4 RECEIVE AND TRANSMIT	8	◇ Opening the case	21
■ Basic voice receive and transmit	8	■ Fuse replacement.....	21
■ Functions for transmit.....	8	◇ DC power cable fuse	21
◇ Transmit frequency check	8	◇ Circuitry fuse.....	21
■ Functions for receive	9	7 TROUBLESHOOTING	22
◇ Squelch function	9	■ Specifications	23
◇ Noise blanker.....	9	8 SPECIFICATIONS AND OPTIONS	23
◇ AGC OFF function	9	■ Options	23
◇ Clarity control.....	9		
■ CW operation.....	10		
■ FSK operation.....	10		
5 SET MODE.....	11		
■ Set mode operation	11		
■ Set mode contents.....	11		

□ CALL PROCEDURES

Calls must be properly identified and time limits must be respected.

- ① Give your call sign each time you call another vessel or coast station. If you have no call sign, identify your vessel name and the name of the licensee.
- ② Give your call sign at the end of each transmission that lasts more than 3 minutes.
- ③ You must break and give your call sign at least once every 15 minutes. during long ship-to-shore calls.
- ④ Keep your unanswered calls short, less than 30 seconds.
Do not repeat a call for 2 minutes.
- ⑤ Unnecessary transmissions are not allowed.

□ PRIORITIES

- ① Read all rules and regulations pertaining to priorities and keep an up-to-date copy handy. Safety and distress calls take priority over all others.
- ② False or fraudulent distress calls are prohibited and punishable by law.

□ PRIVACY

- ① Information overheard but not intended for you cannot be lawfully used in any way.
- ② Indecent or profane language is prohibited.

□ LOGS

- ① All distress, emergency and safety calls must be recorded in complete detail. Log data activity is usually recorded in 24 hour time. Universal Time (UTC) is frequently used.
- ② Adjustments, repairs, channel frequency changes and authorized modifications affecting electrical operation of the equipment must be kept in the maintenance log; entries must be signed by the authorized licensed technician performing or supervising the work.

□ RADIO LICENSES**(1) SHIP STATION LICENSE**

You must have a current radio station license before using the transceiver. It is unlawful to operate a ship station which is not licensed.

Inquire through your dealer or the appropriate government agency for a Ship-Radiotelephone license application. This government-issued license states the call sign which is your craft's identification for radio purposes.

(2) OPERATOR'S LICENSE

A Restricted Radiotelephone Operator Permit is the license most often held by small vessel radio operators when a radio is not required for safety purposes.

The Restricted Radiotelephone Operator Permit must be posted or be kept with the operator. Only a licensed radio operator may operate a transceiver.

However, non-licensed individuals may talk over a transceiver if a licensed operator starts, supervises, and ends the call, and makes the necessary log entries.

Keep a copy of the current government rules and regulations handy.

■ Front panel

This function is not installed in the IC-M700PRO.

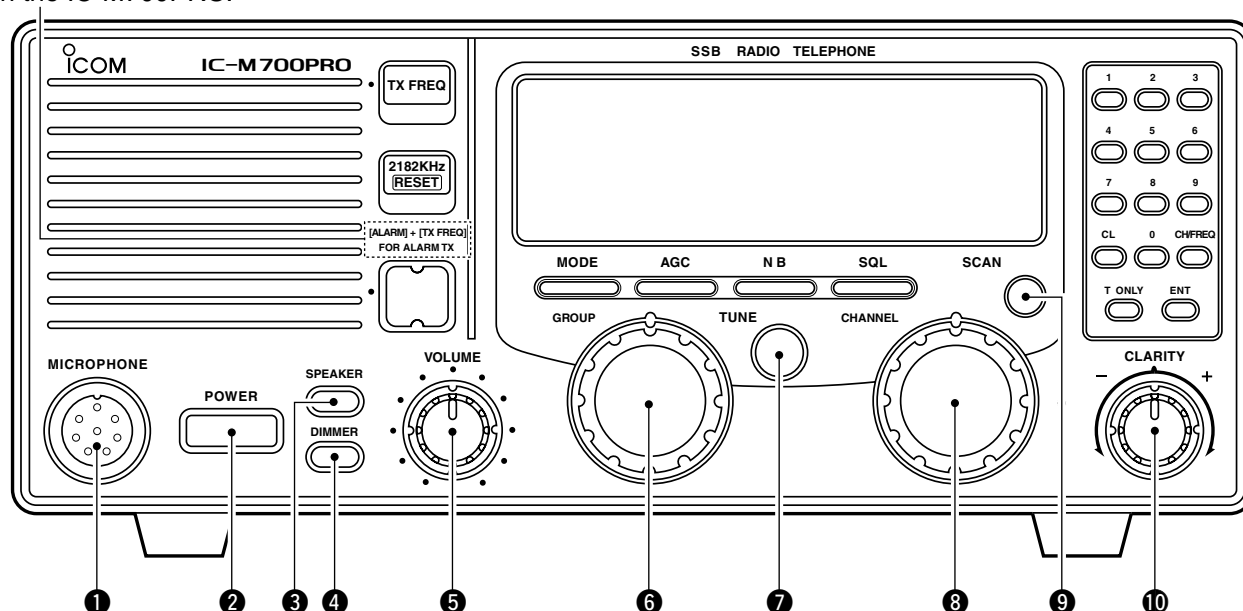

- 1 MICROPHONE CONNECTOR** (p. 16)
Accepts the supplied microphone or an optional handset.
 ⓘ **NOTE:** No audio is output to the speaker when the microphone or handset is not connected.
- 2 POWER SWITCH [POWER]**
Turns power ON or OFF.
- 3 SPEAKER SWITCH [SPEAKER]**
Turns the built-in speaker ON or OFF.
 • “” appears in the display while the speaker is turned OFF.
 • Any external speaker connected to the rear panel is not turned OFF.
- 4 DISPLAY INTENSITY SWITCH [DIMMER]**
Turns the display backlighting ON or OFF.
- 5 VOLUME CONTROL [VOLUME]**
Adjusts the audio output level.
 • No sound is output to the speaker when:
 ➤ A microphone is not connected.
 ➤ The [SQL] switch is turned ON and no signal is being received.
- 6 GROUP CHANNEL SELECTOR [GROUP]**
In the memory mode, selects 1 of 3 channel groups (“A,” “B” or “C”). (p. 5)
 • In the VFO mode, it has no function.
 ➤ Selects an item in the set mode. (p. 11)
- 7 ANTENNA TUNE SWITCH [TUNE]** (p. 8)
Tunes the external tuner to the antenna.
 • Activates only when an optional antenna tuner such as Icom’s AT-130 is connected.
 ⓘ **NOTE:** When selecting “automatic tuning” in the set mode, pushing this switch is not necessary to tune the antenna. (p. 11)
- 8 CHANNEL SELECTOR [CHANNEL]** (p. 5)
 ➤ In the memory mode, selects an operating channel within the selected channel group.
 • A maximum of 50 channels are available in each channel group, depending on set mode setting (pgs. 13 and 14).
 ➤ In the VFO mode, changes the operating frequency in 0.1 kHz steps.
 • Frequencies selected in the VFO mode are temporary.
- 9 SCAN SWITCH [SCAN]** (p. 6)
Push to toggle the scan ON or OFF.
- 10 CLARITY CONTROL [CLARITY]** (p. 9)
Shifts the receive frequency ± 150 Hz for clear reception of an off frequency signal.

2 PANEL DESCRIPTION

■ Front panel (Continued)

This function is not installed in the IC-M700PRO.

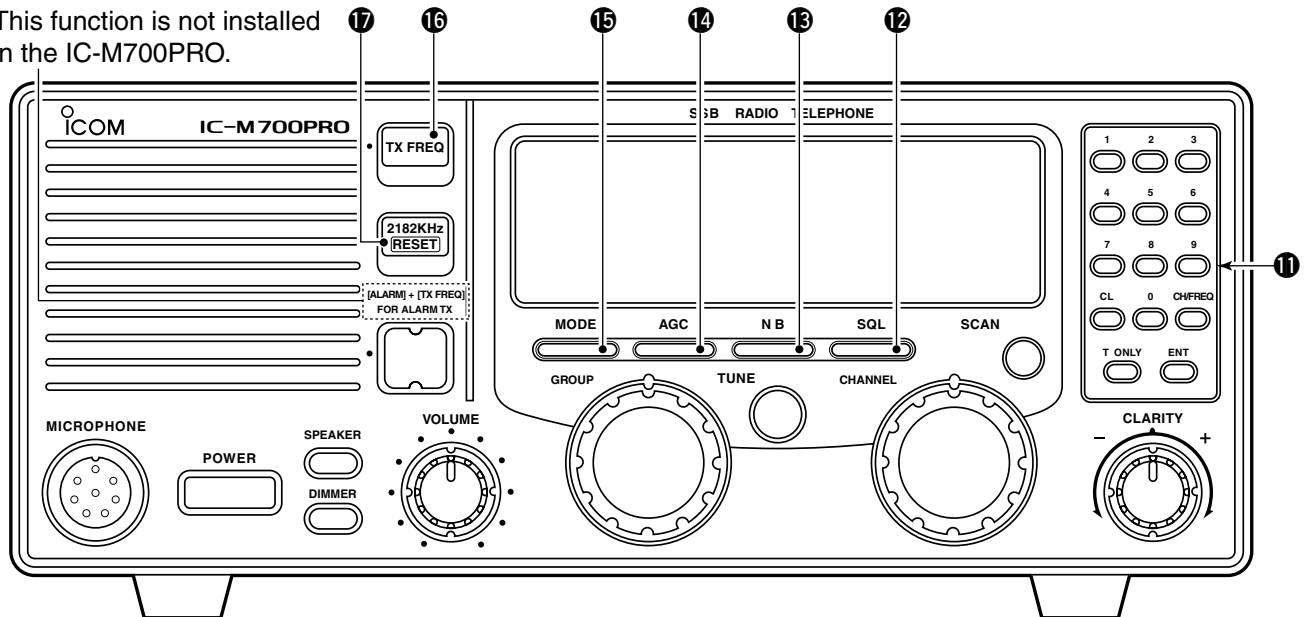

⑪ KEYPAD

CL No function*.

CH/FREQ Toggles between the memory mode and the VFO mode. (p. 5)
• This key may be disabled by your dealer.

T ONLY No function*.

ENT No function*.

0 No function*.

to
9

*These keys function in some versions. See the separate *KEYPAD OPERATION* and *CHANNEL LIST* instruction sheet for operating details.

⑫ SQUELCH SWITCH [SQL] (p. 9)

Activates the voice squelch function to reject undesired background noise while no signal is being received.

- The squelch opens only when the received signal contains no voice or FSK components.

⑬ NOISE BLANKER SWITCH [NB] (p. 9)

Turns the noise blanker function ON to remove pulse-type noise such as engine ignition noise.

- “NB” appears when the function is turned ON.

⑭ AGC OFF SWITCH [AGC] (p. 9)

Deactivates the AGC function to receive weak signals blocked by strong adjacent signals.

- “AGC” appears when the [AGC] switch is turned ON (stands for AGC deactivated).

⑮ MODE SWITCH [MODE]

Temporarily selects an operating mode. Available modes differ with the transceiver version.

- USB, AM, J2B (AFSK), FSK, R3E and CW modes are available.
- The temporary mode is cleared and the previous mode appears when changing a channel.

⑯ TRANSMIT FREQUENCY SWITCH [TX FREQ]

(p. 8)

Displays the transmit frequency and opens the squelch to check and monitor the transmit frequency.

⑰ 2182 kHz SELECTION SWITCH

[2182KHz • RESET] (p. 5)

- ➔ Selects channel 0 (2182 kHz; distress call frequency).
 - The channel selector does not function when selecting channel 0.
- ➔ Ignores external control and gives the front panel control priority when an external controller (NMEA format) is connected.

■ Display

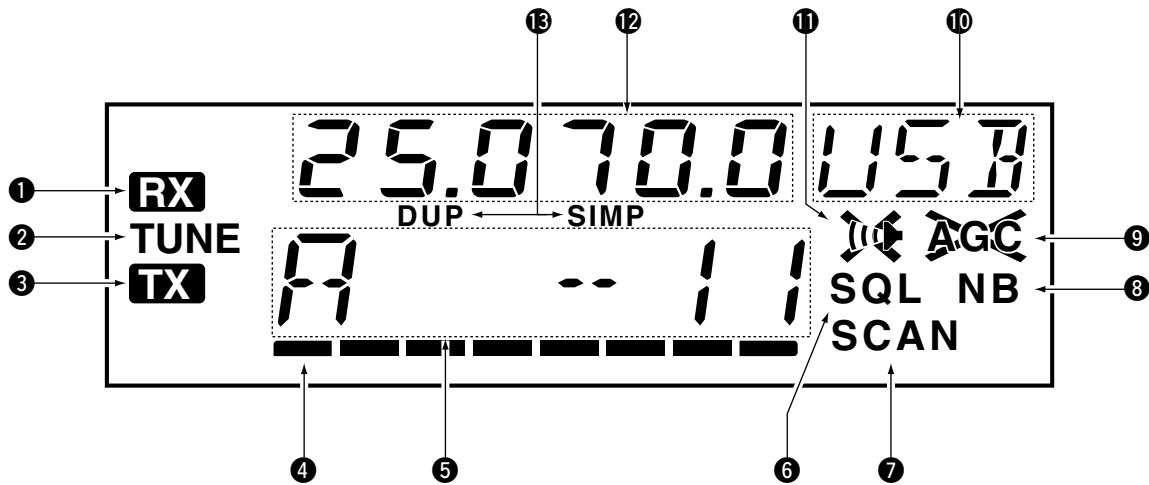

1 RECEIVE INDICATOR

Appears while receiving and when the squelch is open.

2 TUNE INDICATOR (p. 8)

Flashes while the connected antenna tuner, such as Icom's AT-130, is being tuned.

- Tuning starts when transmitting on a new frequency or pushing the [TUNE] switch.

3 TRANSMIT INDICATOR

Appears when transmitting.

4 S/Rf METER

- Shows the relative received signal strength while receiving.
- Shows output power while transmitting.

5 CHANNEL/VFO INDICATOR (p. 5)

- Shows the selected group and channel in the memory mode.
- "FREQ" appears in the VFO mode.

6 SQUELCH INDICATOR (p. 9)

Appears when the squelch is ON.

7 SCAN INDICATOR (p. 6)

Appears when the scan function is in use.

- The scan function is not available on some versions.
- Pushing [SCAN] starts and stops the scan.

8 NOISE BLANKER INDICATOR (p. 9)

Appears when the [NB] switch is turned ON.

9 AGC OFF INDICATOR (p. 9)

Appears when the [AGC] switch is pushed to indicate the AGC function is deactivated.

10 MODE READOUT

Shows the selected operating mode (type of emission).

11 SPEAKER OFF INDICATOR

Appears when the [SPEAKER] switch is pushed to indicate the front panel speaker is deactivated.

12 FREQUENCY READOUT

- Shows the selected frequency whether in the memory mode or the VFO mode. (p. 5)
- Shows the transmit frequency (for duplex channels) when transmitting or when pushing [TX FREQ]. (p. 8)

13 SIMPLEX/DUPLEX INDICATORS

These appear to show whether the selected channel is simplex or duplex.

- In the VFO mode, only simplex channels are available.
- No indicator means that there is no transmit frequency programmed.

Memory mode/VFO mode

The transceiver has 2 operating modes: *memory mode* and *VFO mode*. The memory mode is used to select preprogrammed marine channels in one of the 3 channel groups; The VFO mode is used to select frequencies around preprogrammed channels.

Push [CH/FREQ] to toggle between the memory and VFO modes.

- "FREQ" appears when in the VFO mode.
- In the VFO mode, only simplex operation is possible.

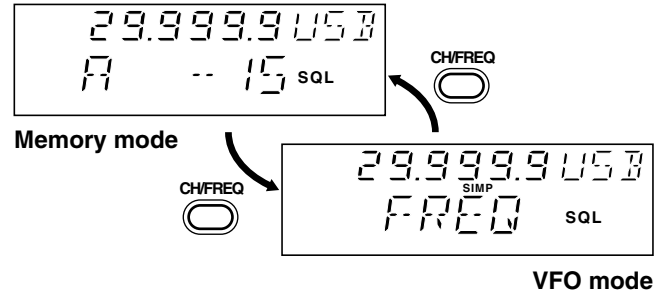

Selecting a channel

The transceiver has 150 channels divided into 3 groups of 50 channels, maximum. However, the number of channels in each group can be restricted in the set mode, depending on your needs. (pgs. 13 and 14)

NOTE: When channel 0 and/or 2182 kHz is selected with the [2182KHz] switch, channel selection is NOT possible. In such cases, push [2182KHz] first.

- ① If necessary, push [CH/FREQ] to select the memory mode.
- ② Rotate the [GROUP] selector to select the desired channel group; then rotate the [CHANNEL] selector to select the desired channel.

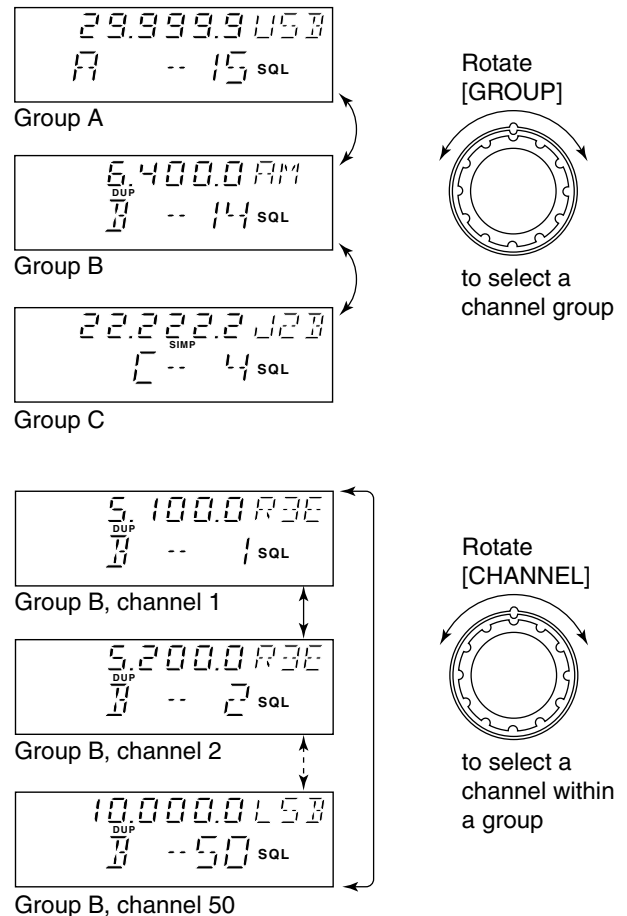

◇ **Scan function**

The scan function allows you to automatically search for signals with a group of channels. There are 2 scan types (selectable in the set mode) as follows:

Channel scan

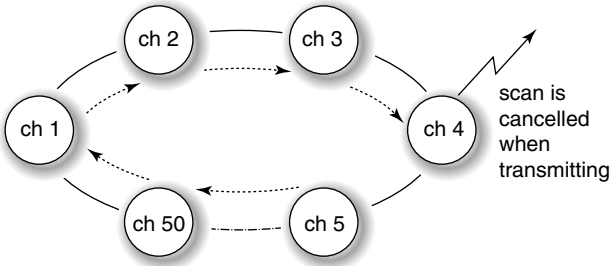

Channel resume scan

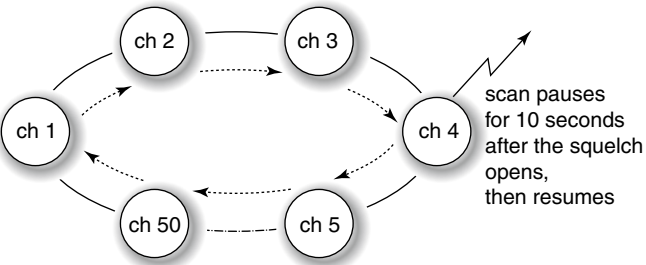

Scan operation

- ① Rotate the [GROUP] selector to select the group you wish to scan.
- ② If necessary, push [SQL] to close the squelch.
 - “SQL” appears.
- ③ Push [SCAN] to start scanning.
 - “SCAN” appears.
- ④ Push [SCAN] again to stop scanning.
 - “SCAN” disappears.

■ **Selecting a frequency**

The transceiver has 0.5 to 30.0 MHz general coverage receive capability, with 100 Hz resolution. Use the VFO mode to select frequencies around the pre-programmed channels in the memory mode.

🔊 **NOTE:** Frequencies selected in the VFO mode are for temporary use and are not stored in memory.

- ① While in the memory mode, rotate the [GROUP] and [CHANNEL] selectors to select the channel nearest the frequency you want.
- ② Push [CH/FREQ] to select the VFO mode.
 - “FREQ” appears.
- ③ Rotate the [CHANNEL] selector to select the desired frequency.
 - The frequency changes in 100 Hz steps.

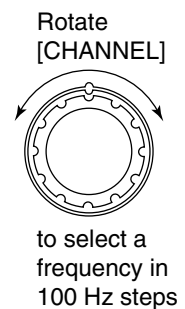
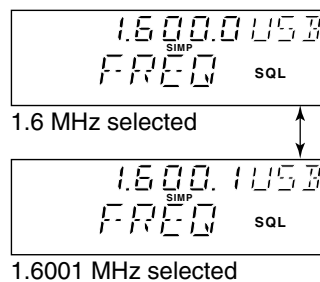

3 SELECTING A CHANNEL/FREQUENCY

■ Resetting the CPU

Under some circumstances, the transceiver's internal CPU may cause erroneous indications on the display. If this happens, reset the CPU as follows:

While pushing [ENT] and [0], push [POWER] to turn power ON.

- The CPU is reset and the display at right appears.

CAUTION: Resetting the CPU returns the set mode contents to their default values.



Group A, channel 1 is selected after resetting the CPU.

Basic voice receive and transmit

- ① Check the following in advance:
 - The microphone is connected.
 - The [SPEAKER] switch is turned OFF.
 - The [SQL] switch is turned OFF.
 - The [CLARITY] control is set to the center position.
 - The memory mode is selected.
- If necessary, push [CH/FREQ] to select the memory mode.

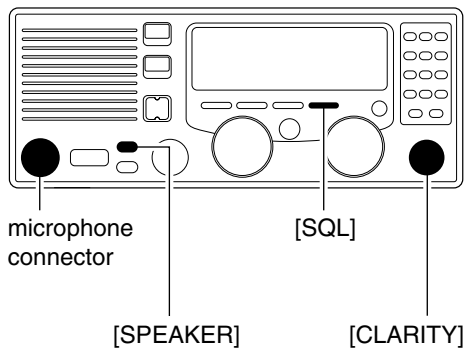

- ② Select the desired channel to be received with the [GROUP] and [CHANNEL] selectors.
 - When receiving a signal, the S-meter shows the signal strength.
- ③ Adjust [VOLUME] to the desired audio level when receiving a signal.
- ④ If the received signal is in a different mode, push [MODE] to select the desired operating mode.
- ⑤ If connected, push [TUNE] to tune the antenna tuner.
 - This operation is not necessary when “automatic tuning” is selected in the set mode (p. 11).
- ⑥ To transmit on the channel, push and hold the PTT switch on the microphone.
 - “TUNE” flashes for 1 to 2 seconds for the first transmission on a channel when an antenna tuner is connected.
- ⑦ After the flashing stops, speak into the microphone at your normal voice level.
 - The RF meter shows the output power, according to your voice level.
- ⑧ Release the PTT switch to return to receive.

Functions for transmit

◇ Transmit frequency check

When “DUP” appears on the display, such as for a ship-to-shore channel, the transmit frequency differs from the receive frequency.

In such cases, the transmit frequency should be monitored before transmitting to prevent interference to other stations.

Push and hold [TX FREQ] to monitor the transmit frequency.

- The display shows the transmit frequency.

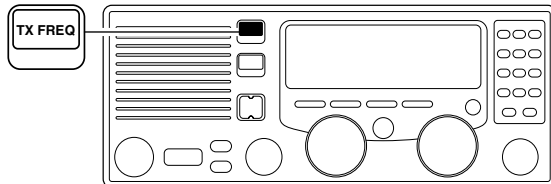

■ Functions for receive

◇ Squelch function

The squelch function detects signals with voice components and squelches (mutes) unwanted signals, such as unmodulated beat signals. This provides quiet standby.

When you need to receive weak signals, the squelch should be turned OFF.

Push [SQL] to toggle the function ON or OFF.

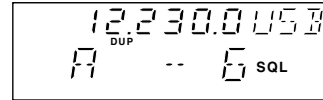

- “SQL” appears when the squelch function is turned ON.

◇ Noise blanker

The noise blanker function reduces pulse type noise, such as that coming from engine ignitions.

The noise blanker may distort reception of strong signals. In such cases, the noise blanker should be turned OFF.

Push [NB] to toggle the function ON or OFF.

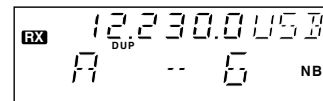

- “NB” appears when the noise blanker function is turned ON.

◇ AGC OFF function

The receiver gain is automatically adjusted according to the received signal strength with the AGC (Automatic Gain Control) function, to prevent distortion from strong signals and to obtain a constant output level.

When receiving weak signals with adjacent strong signals or noise, the AGC function may reduce the sensitivity. In this situation, the AGC function should be deactivated.

Push [AGC] to toggle the function ON or OFF.

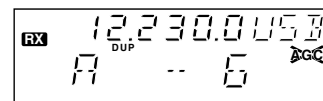

- “AGC” appears when the AGC function is deactivated.

◇ Clarity control

Voice signals received from other stations may be difficult to receive. This may sometimes happen if a station is transmitting slightly off frequency. In such cases, vary the receive frequency only, using the [CLARITY] control.

Adjust [CLARITY] to improve the audio signal.

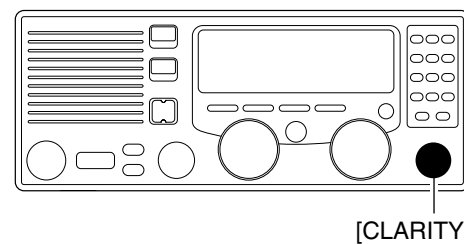

■ CW operation

The transceiver has the following CW keying features selectable in the set mode, as described on page 12.

- ➔ Full break-in (receiving is possible while transmitting)
- ➔ Semi break-in (automatic transmission with keying)
- ➔ OFF (manual transmission is necessary before keying)

- ① Connect a CW keyer or an external electronic keyer to the ACC(1) socket, as shown at right.
- ② Select the desired channel to operate in the CW mode.
- ③ When the selected channel is not in the CW mode, push [MODE] one or more times to select "CW."
- ④ Operate the CW keyer to transmit a CW signal.

NOTE:

- ➔ CW mode is not available in some versions.
- ➔ CW narrow can be selected in the set mode when an optional filter is installed. (p. 12)

CW key connection

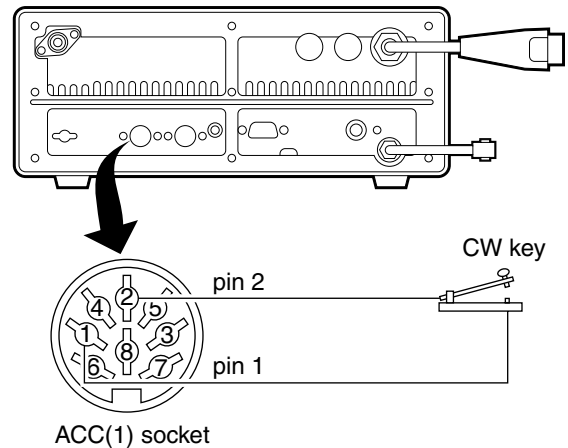

■ FSK operation

The transceiver has FSK and J2B modes for FSK operation—use FSK when using the built-in oscillator; use J2B when using an AFSK terminal unit.

- ① Connect an FSK terminal unit as shown at right.
- ② Select the desired channel.
 - FSK channels are available, depending on the version.
- ③ Push [MODE] one or more times to select either "FSK" or "J2B."
- ④ Operate the FSK terminal unit.

NOTE:

- ➔ FSK shift frequency and FSK polarity can be adjusted in the set mode (p. 12).
- ➔ Some transceivers may operate 1.7 kHz higher than the IC-M700PRO's J2B mode, even when the same displayed frequencies are in use.

FSK terminal unit connection

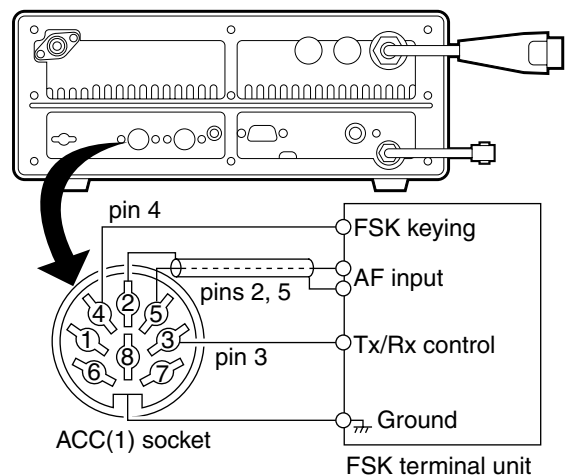

■ Set mode operation

Set mode operation is used for programming infrequently changed values or functions.

NOTE: Some of the set mode items described in this section are not available on some transceiver versions.

- ① If necessary, push [POWER] to turn power OFF.
- ② While pushing [ENT] and [1], push [POWER] to turn power ON and enter the set mode.
- ③ Rotate the [GROUP] selector to select the desired item.
- ④ Rotate the [CHANNEL] selector to set the values or options for the selected item.
- ⑤ Turn power OFF and then ON again to exit the set mode.

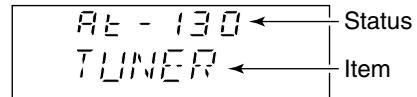
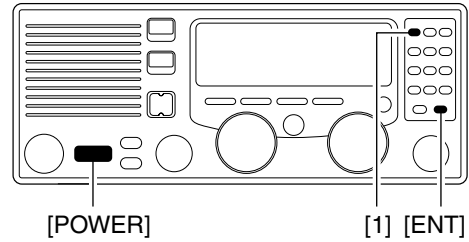

■ Set mode contents

(1) Antenna tuner

The transceiver has several tuner control systems for use with an optional Icom antenna tuner. Select the condition, depending on the antenna tuner you are using.

NOTE: An internal switch selection may be required when using a non-Icom tuner (p. 19).

<pre>AT - 130 TUNER</pre>	AT-130 (default)
<pre>AT - 120 TUNER</pre>	AT-120
<pre>AH - 3 TUNER</pre>	AH-3

(2) Automatic tuning operation

When the optional AT-130 automatic antenna tuner is connected, tuning can be started automatically without the [TUNE] switch, for instant operation.

If manual tuning is required, this automatic operation can be deactivated.

<pre>ON AT - TUN</pre>	Tuning starts when pushing [PTT] on a new frequency.
<pre>OFF AT - TUN</pre>	Tuning starts only when [TUNE] is pushed. (default)

(3) Scan type selection

This item sets scan to function as “channel scan” or “channel resume scan.”

Both channel scan and channel resume scan search around a user selected channel or search in the band when a channel is selected.

<pre>CH SC - TYP</pre>	<i>Channel scan</i> Scan is canceled when transmitting.
<pre>CH - RES SC - TYP</pre>	<i>Channel resume scan</i> Scan pauses when squelch opens, then resumes after 10 seconds. (default)

(4) Scan speed

Selects scan speed as follows:

(unit: sec./ch)

2	3	4	5	6	7	8	9	10
2	3	4	5	6	7	8	9	10

Faster

Slower

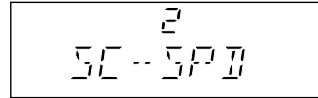

Fastest scan speed (default)

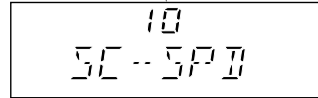

Slowest scan speed

(5) CW/FSK narrow filter

This selects the passband width for CW (A1A), FSK or J2B mode.

NOTE: When "ON" is selected without the optional filter installed, the transceiver does not function in these modes.

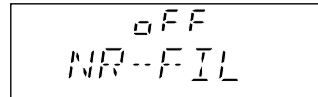

Passband: 2.3 kHz/-6 dB (default)

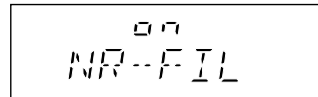

Passband: 500 Hz/-6 dB

(6) FSK frequency shift

Several shift settings (the difference between the mark and space frequency) are used for FSK operation. This item allows you to select a shift setting for almost any FSK system.

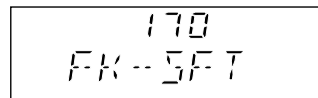

Frequency shift: 170 Hz (default)

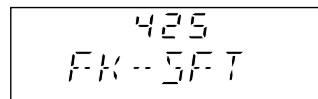

Frequency shift: 425 Hz

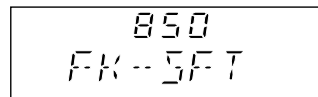

Frequency shift: 850 Hz

(7) FSK polarity

Normal and reverse polarities are available for FSK operation. This item allows you to select one of these polarities.

"FK-REV OFF" (normal):
key open (mark); key close (space)

"FK-REV ON" (reverse):
key open (space); key close (mark)

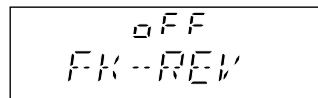

FSK normal (default)

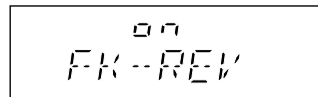

FSK reverse

(8) CW break-in

The CW break-in function (in A1A mode) toggles transmit and receive with CW keying. Full break-in allows you to receive signals between transmitted keying pulses during CW transmission. Semi break-in allows you to mute receiving until keying stops with a delay time.

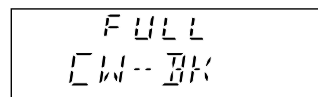

Full break-in
Automatic keying without delay time (default)

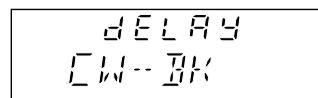

Semi break-in
Automatic keying with delay time

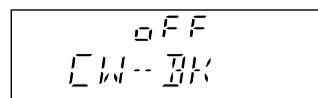

OFF
Manual transmission necessary for keying

5 SET MODE

(9) LCD contrast

The LCD contrast can be adjusted through 10 levels, to suit transceiver mounting angle, location and ambient lighting.

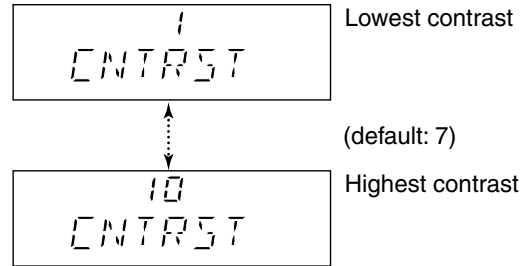

(10) ID number setting for remote control

When connecting an external controller, such as a personal computer, 2-digit ID codes are required to access the transceiver. The IC-M700PRO adopts the NMEA0183 format, and uses a "proprietary sentence" for remote control.

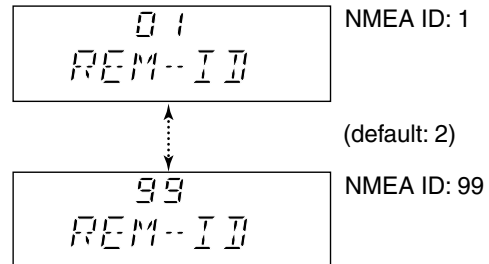

(11) Remote control input terminal

Remote control signals can be input via the [REMOTE] socket or [CLONE] jack.

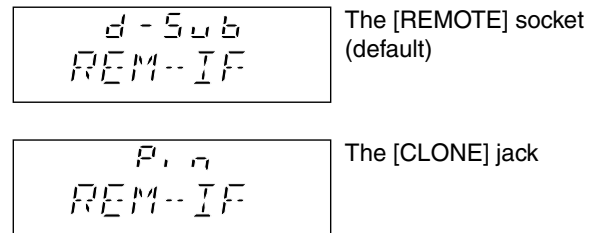

(12) Display backlighting

Allows you to select 1 of 4 intensity levels for the display backlighting.

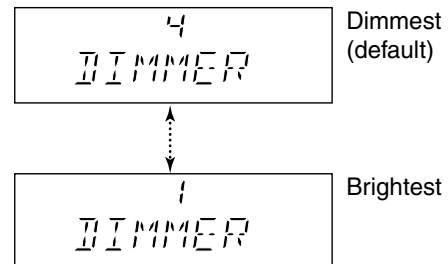

(13) Group A channel inhibit

This item allows you to set the number of usable channels in channel group A, up to a maximum of 50 channels.

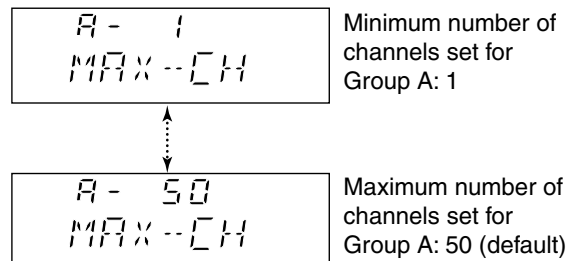

(14) Group B channel inhibit

This item allows you to set the number of usable channels in channel group B, up to a maximum of 50 channels.

b - 1
MAX -- CH

Minimum number of channels set for Group B: 1



b - 50
MAX -- CH

Maximum number of channels set for Group B: 50 (default)

(15) Group C channel inhibit

This item allows you to set the number of usable channels in channel group C, up to a maximum of 50 channels.

c - 1
MAX -- CH

Minimum number of channels set for Group C: 1



c - 50
MAX -- CH

Maximum number of channels set for Group C: 50 (default)

■ Connections on the rear panel

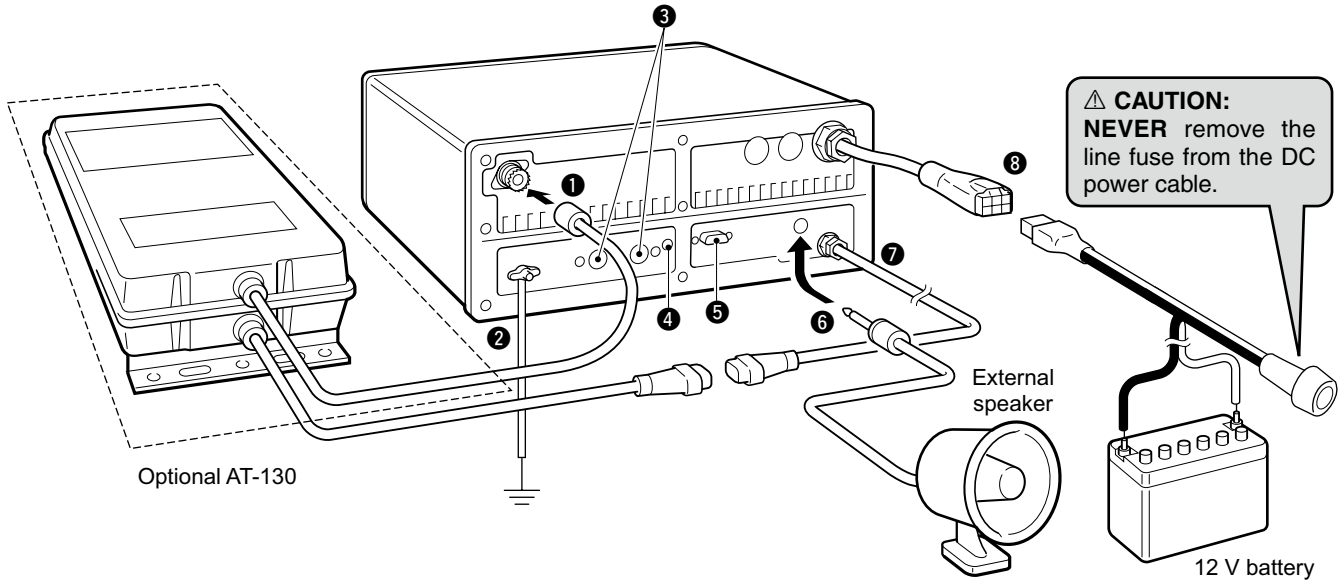

- 1 ANTENNA CONNECTOR** (p. 19)
Connects a 50 Ω HF band antenna with a 50 Ω matched coaxial cable and a PL-259 plug.
- 2 GROUND TERMINAL**
IMPORTANT! Connects to a ship's (or vehicle's) ground. See p. 18 for details.
- 3 ACC(1) and ACC(2) SOCKETS**
See p. 16 for details.
- 4 CLONE JACK**
For Dealer use only.
- 5 REMOTE SOCKET** (p. 17)
REMOTE socket for Marine and General versions.
- 6 EXTERNAL SPEAKER JACK**
Connects a 4 to 8 Ω external speaker using a ¼" monaural plug. This external audio is not muted by the [SPEAKER] switch on the front panel.

- 7 TUNER RECEPTACLE**
Connects a control cable to an optional AT-130 ANTENNA TUNER. A female connector is supplied for connection.
- 8 DC POWER RECEPTACLE**
Connects to a regulated 12–16 V DC power source such as a 12 V battery or DC power supply using the supplied DC power cable.

CAUTION: DO NOT connect to a 24 V battery. This will damage the transceiver.

■ Unpacking

Microphone (HM-180)	1
Microphone hanger	1
DC power cable (OPC-1107A)	1
Mounting bracket	1
Cushion rubber	4
Bracket knobs (8820000170)	4
Flat washer (M5)	4
CONNECTORS	
DIN connector (8-pin for ACC1)	1
DIN connector (7-pin for ACC2)	1
Speaker plug (5610000440)	1
Tuner connector (5610000150)	1
Pins for tuner connector (5610000160)	4
Plates for tuner connector (69100009540)	4

NUTS AND BOLTS	
Allen bolt (M6 × 50)	4
Self-tapping screws (M6 × 30)	4
Nuts (M6; use 2 pcs. for each bolt)	8
Flat washers (M6)	8
Spring washers (M6)	4
Self-tapping screws (M3 × 16 for mic. hanger)	2

FUSES	
DC power cable (30 A)	1
1205 (internal)	2

■ Connector information

ACC(1)	PIN	PIN NAME	DESCRIPTION	SPECIFICATIONS
	1	CWK	CW and FSK keying input.	Input level: Less than 0.6 V for transmit.
	2	GND	Connects to ground.	Connected in parallel with ACC(2) pin 2.
	3	SEND	Input/output pin. Goes to ground when transmitting. When grounded, transmits.	Ground level: -0.5 to 0.8 V Input current: Less than 20 mA Connected in parallel with ACC(2) pin 3.
	4	MOD	Modulator input. Usable when pin 3 is grounded.	Input impedance: 10 kΩ Input level: Approx. 100 mV rms
	5	AF	AF detector output. Fixed, regardless of the [AF] position.	Output impedance: 4.7 kΩ Output level: 100–300 mV rms
	6	NC	No connection.	
	7	13.6 V	13.6 V output when power is ON.	Output current: Max. 1 A Connected in parallel with ACC(2) pin 7.
	8	ALC	ALC voltage input.	Control voltage: -3 to 0 V Input impedance: More than 10 kΩ Connected in parallel with ACC(2) pin 5.

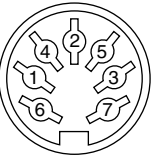
ACC(2)	PIN	PIN NAME	DESCRIPTION	SPECIFICATIONS
	1	8 V	Regulated 8 V output.	Output voltage: 8 V ±0.3 V Output current: Less than 10 mA
	2	GND	Same as ACC(1) pin 2.	
	3	SEND	Same as ACC(1) pin 3.	
	4	NC	No connection.	
	5	ALC	Same as ACC(1) pin 8.	
	6	RLC	T/R relay control output.	When transmitting: 0 V (less than 0.5 A)
	7	13.6 V	Same as ACC(1) pin 7.	

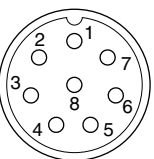
MICROPHONE	PIN	PIN NAME	DESCRIPTION	SPECIFICATIONS
	1	MIC+	Audio input from the microphone element.	Input impedance: 600 Ω
	2	NC	No connection.	
	3	AF1	AF output controlled with [VOLUME]. Connected to pin 4 in the microphone.	Output impedance: 4 Ω
	4	AF2	AF input. Connected to pin 3 in the microphone.	
	5	PTT	PTT switch input.	When grounded, transmits.
	6	GND	Connected to ground.	
	7	MIC-	Coaxial ground for MIC+.	
	8	AF-	Coaxial ground for AF1 and AF2.	

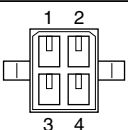
TUNER	PIN	PIN NAME	DESCRIPTION	SPECIFICATIONS
	1	KEY	Key signal input.	-0.5 to 0.8 V during tuning
	2	START	Start signal output.	Pulled up 8 V, 0 V(100 msec) as start signal.
	3	13.6V	13.6 V output	Max. current: 2 A
	4	E	⊖ terminal	Ground

6 CONNECTIONS AND INSTALLATION

■ Connector information (Continued)

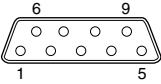
REMOTE	PIN	PIN NAME	DESCRIPTION	SPECIFICATIONS
	1	MOD+	Modulation input from an external terminal unit.	Input impedance: 600 Ω Input level: Approx. 1.3 mV rms
	2	MOD-	Coaxial ground for MOD+.	
	3	AF+	AF detector output for an external terminal unit.	Output impedance: 600 Ω Output level: 0.25–2.5 V rms
	4	AF-	Coaxial ground for AF+.	
	5	NMI+	NMEA data input.	NMEA standard format/level
	6	NMI-	Coaxial ground for NMI+.	
	7	NMO+	NMEA data output.	NMEA standard format/level
	8	NMO-	Coaxial ground for NMO+.	
	9	GND	Ground for digital equipment.	

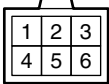
DC 13.6V	PIN	PIN NAME	DESCRIPTION	SPECIFICATIONS
	1–3	+	+ DC input	Max. power consumption: 30 A
	4–6	-	_ DC input	

■ Ground connection

The transceiver and antenna tuner **MUST** have an adequate ground connection. Otherwise, the overall efficiency of the transceiver and antenna tuner installation will be reduced. Electrolysis, electrical shocks and interference from other equipment could also occur.

For best results, use the heaviest gauge wire or strap available and make the connection as short as possible. Ground the transceiver and antenna tuner to one ground point, otherwise voltage differences between 2 ground points may cause electrolysis.

CAUTION: The IC-M700PRO has a negative ground. **NEVER** connect the IC-M700PRO to a “positive ground system,” otherwise the transceiver will not function.

Ground system example

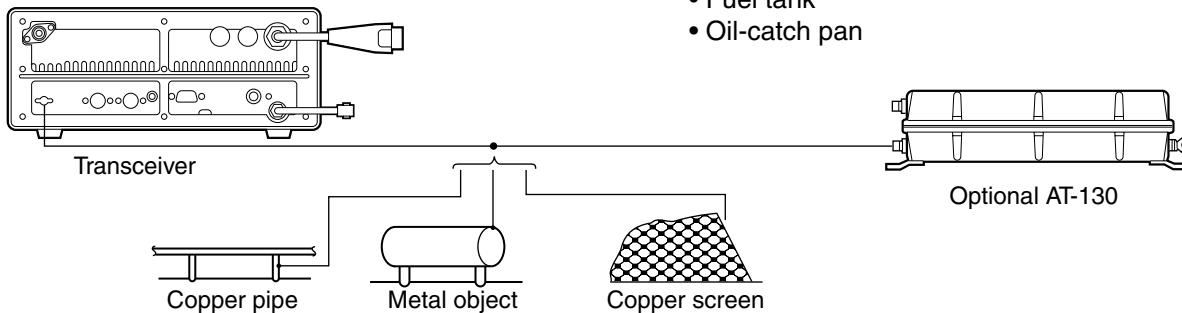

Good ground points

- Ship's ground terminal
- External ground plate
- External copper screen

Acceptable ground points

- Stainless steel tuna tower
- Stainless steel stanchion
- Through mast
- Through hull
- Metal water tank

Undesirable ground points

(these points may cause electrolysis)

- Engine block
- Keel bolt

Unusable ground points

(these connections may cause an explosion or electrical shock)

- Gas or electrical pipe
- Fuel tank
- Oil-catch pan

■ Power source

The transceiver requires regulated DC power of 13.6 V and at least 30 A. There are 3 ways to supply power:

- A direct connection to a 12 V battery in your ship, through the supplied DC power cable.

CAUTION: The supplied DC power cable **MUST** be used to provide power to the transceiver. **AVOID** exceeding the 3 m (10 ft) length of the DC power cable. If it is necessary to make a run of over 3 m (10 ft), use a #6 or similar gauge wire instead of the supplied DC power cable, for a maximum run of 6 m (20 ft).

DC power cable connection

NOTE: Use terminals for the cable connection.

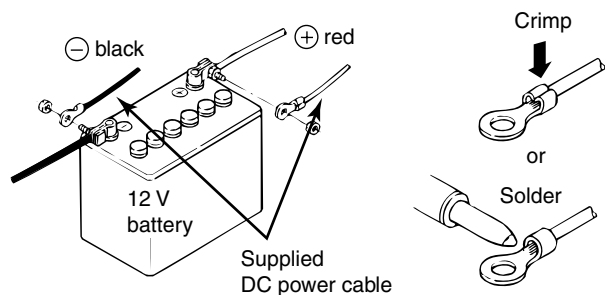

■ Antenna

Most stations operate with a whip or long wire (insulated backstay) antenna. However, these antennas cannot be connected directly to the transceiver, since their impedance may not be matched with the transceiver antenna connector.

Even with a 50 Ω matched antenna, all marine bands may not be fully usable. The following antenna matcher, or antenna tuner may be helpful for proper antenna installation.

◇ MN-100/MN-100L ANTENNA MATCHERS

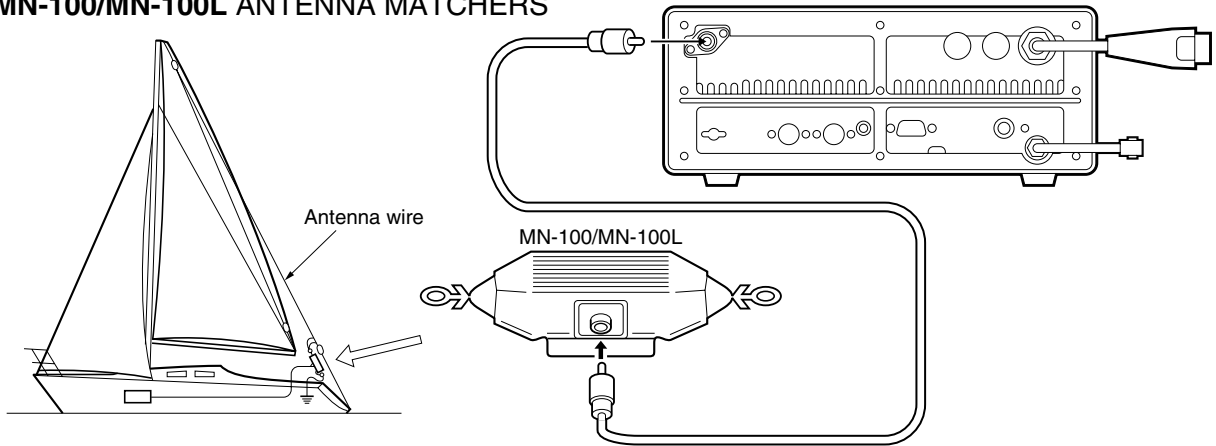

◇ AT-130 AUTOMATIC ANTENNA TUNER

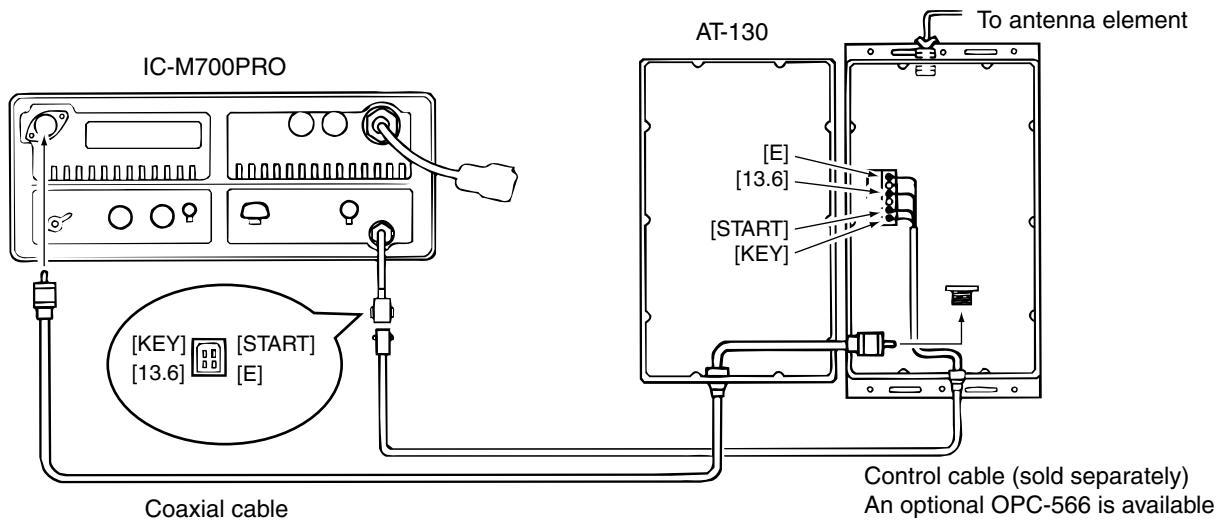

◇ Non-Icom tuner

Some non-Icom tuners may be used with the IC-M700PRO. Please consult your dealer or marina if you wish to use one. The following internal settings may be required for connection.

- Supplies 8 V when pushing [TUNE].
S9 (Start port level)
- Grounded when pushing [TUNE]. (used for AT-130—default)
- Accepts “LOW” as an answer back signal.
S11 (Key port input)
- Accepts “HIGH” as an answer back signal. (used for AT-130—default)

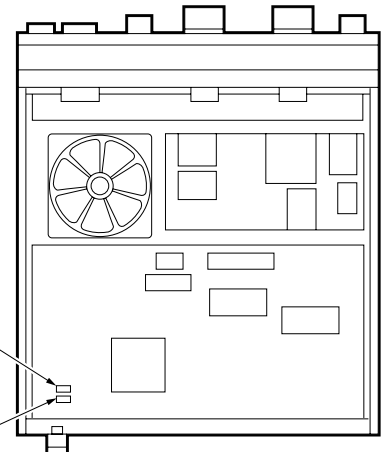

■ Mounting

⚠ **WARNING: NEVER** mount the transceiver overhead. The weight of the transceiver is approximately 7.9 kg. (17.4 lb), but its apparent weight will increase several fold due to wave shocks or vibration. The transceiver must be mounted on a flat, hard surface.

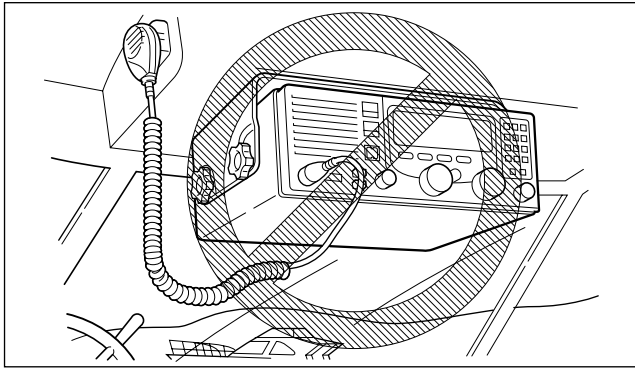

◇ Mounting location

Select a location that provides easy access to the front panel for navigation safety, has good ventilation and is not subject to sea spray. The face of the transceiver should be at 90 degrees to your line of sight when operating it.

CAUTION: KEEP the transceiver and microphone at least 1 meter away from your vessel's magnetic navigation compass.

Check the installation angle; the display may not be easy to read at some angles.

◇ Mounting example

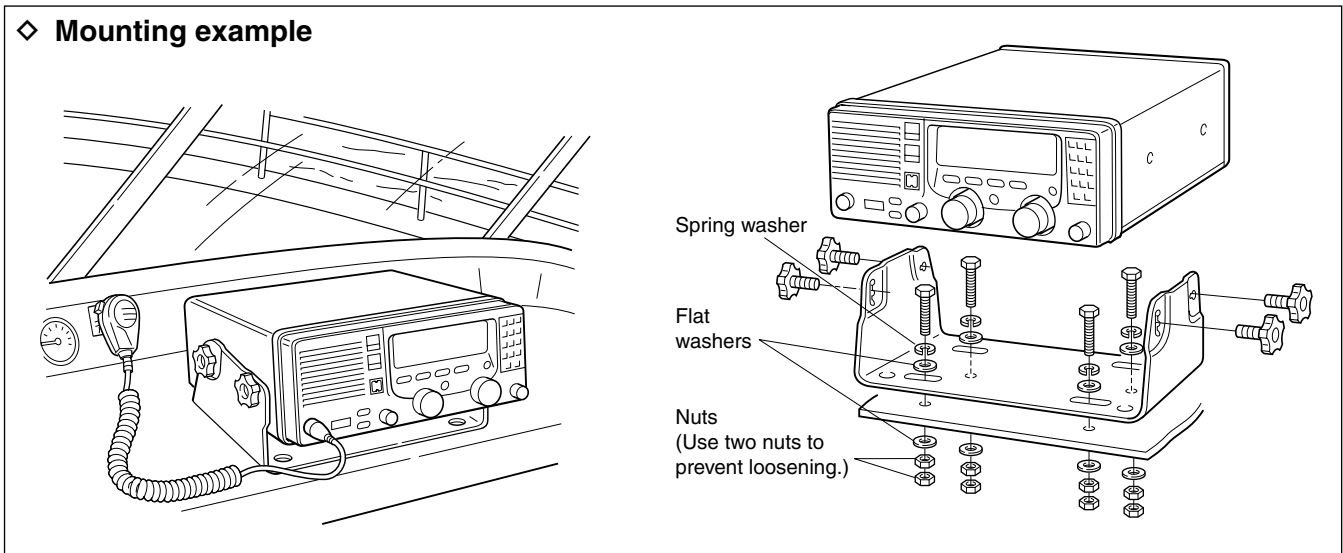

◇ Transceiver dimensions

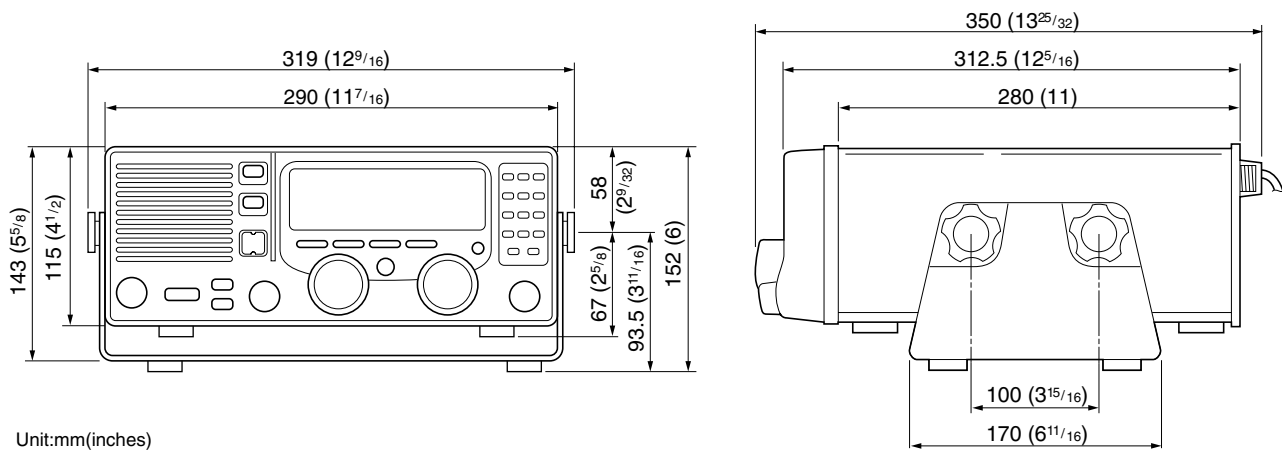

Disassembling the transceiver

Opening the case

Follow the case and cover opening procedures shown here when you want to adjust a setting for non-Icom tuner control.

- ① Remove the 9 screws from the rear panel, then remove the rear frame and rear sealing.
- ② Remove the transceiver case.
- ③ When reassembling the transceiver, check the following points:
 - Internal fan and slits in the case are on the same side.
 - Front sealing is mated correctly.
 - Rear sealing is attached in the proper orientation.
 - Screws are tightened securely.

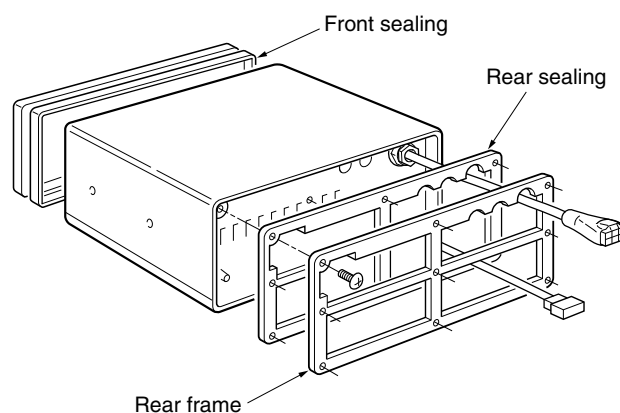

Fuse replacement

The fuses are installed in the DC power cable and the circuitry in the body, to protect the transceiver.

DC power cable fuse

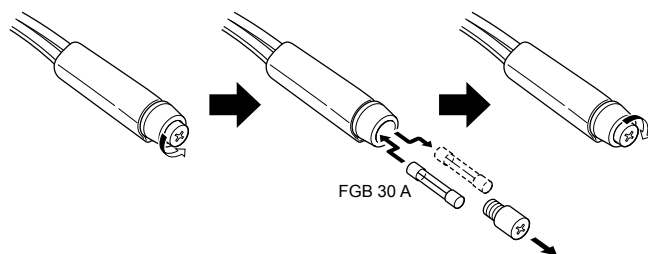

Circuitry fuse

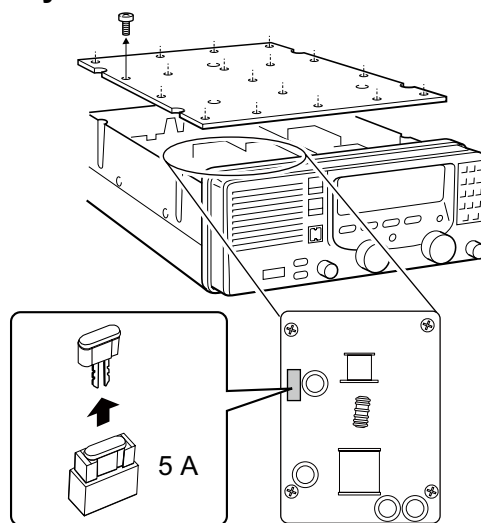

What appears to be equipment malfunction may not be damaging or difficult to solve. Check the following chart before making any adjustments or sending the transceiver to an Icom Service Center.

	PROBLEM	POSSIBLE CAUSE	SOLUTION	REF.
POWER	Power does not come ON when [POWER] is pushed.	<ul style="list-style-type: none"> • Power cable is improperly connected. • The DC power cable fuse or circuitry fuse is blown. 	<ul style="list-style-type: none"> • Reconnect the cable securely. • Find and repair the cause of the problem and then replace the damaged fuse with a new one. 	p. 18 p. 21
	RECEIVE	No sound comes from the speaker.	<ul style="list-style-type: none"> • The [SPEAKER] switch is turned OFF. • Microphone is not connected. • The squelch is closed. 	<ul style="list-style-type: none"> • Turn ON the [SPEAKER] switch. • Connect the microphone to the [MICROPHONE] connector. • Adjust the squelch to proper level or push [SQL] to turn it OFF to receive weak signals.
Sensitivity is too low and only strong signals are audible.		<ul style="list-style-type: none"> • Antenna is not properly matched to the operating frequency. • Wrong tuner is selected in the set mode. • The squelch is set to deep. 	<ul style="list-style-type: none"> • Push [TUNE] to tune the using antenna tuner or select “automatic tuning” in the set mode when using an optional AT-130. • Set the proper tuner for the connected tuner. • Adjust the squelch to proper level. 	pgs. 2, 11 p. 11 p. 9
The received audio is unclear or distorted.		<ul style="list-style-type: none"> • Wrong operating mode is selected. • AGC is deactivated while receiving a strong signal. • Noise blanker is turned ON when receiving a strong signal. • The [CLARITY] control is rotated too far clockwise or counterclockwise. 	<ul style="list-style-type: none"> • Push [MODE] to select the proper operating mode. • Push [AGC] to activate the AGC function. • Push [NB] to turn the noise blanker OFF. • Adjust the [CLARITY] control to receive proper audio output. 	p. 3 p. 9 p. 9 p. 9
TRANSMIT	Your signal does not reach as far away as usual.	<ul style="list-style-type: none"> • The antenna tuner is improperly matched to the operating frequency when manual tuning is selected. • CW or FSK mode is selected for voice transmission. 	<ul style="list-style-type: none"> • Push [TUNE] to tune the using antenna tuner, or select “automatic tuning” in the set mode. • Push [MODE] to select USB mode (or AM, R3E, etc.). 	pgs. 2, 11 p. 3
	Transmit signal is unclear or distorted.	<ul style="list-style-type: none"> • The wrong operation mode is selected. • Microphone is too close to your mouth. 	<ul style="list-style-type: none"> • Push [MODE] to select the proper operating mode. • Speak into the microphone naturally and do not hold the microphone too close to your mouth. 	p. 3 —
DISPLAY	All indicators appear and the channel number can not be read.	<ul style="list-style-type: none"> • The highest contrast is selected in the set mode. 	<ul style="list-style-type: none"> • Set to the proper display contrast. 	p. 13

Specifications

GENERAL

- Frequency coverage :

Receive	500 kHz–29.999 MHz	
Transmit	1.6– 2.9999 MHz	4.0– 4.9999 MHz
	6.0– 6.9999 MHz	8.0– 8.9000 MHz
	12.0– 13.9999 MHz	16.0– 17.9999 MHz
	18.0– 19.9999 MHz	22.0– 22.9999 MHz
	25.0– 27.5000 MHz	
- Mode : USB, AM, CW, FSK and AFSK
(available modes differ with the version)
- Number of channels : 150 channels (max.)
3 groups of 50 channels each
- Antenna impedance : 50 Ω nominal
- Usable temp. range : -30°C to $+60^{\circ}\text{C}$
(-22°F to $+140^{\circ}\text{F}$)
- Frequency stability : ± 10 Hz
(-30°C to $+60^{\circ}\text{C}$; -22°F to $+140^{\circ}\text{F}$)
(± 20 Hz above 15 MHz for General and Marine versions)
- Power supply requirement : 13.6 V DC $\pm 15\%$
(negative and floating grounds available depending on the version)
- Current drain :

Transmit (max. output power)	30 A
Receive (max. audio output)	2.5 A (negative ground)
- Dimensions : 291.4(W) \times 116.4(H) \times 315(D) mm
(projections not included) 11.3(W) \times 4.4(H) \times 12.8(D) in
- Weight (approx.) : 7.9 kg; 17.4 lb

TRANSMITTER

- Output power : 150 W PEP
(60 W above 24 MHz)
- Spurious emissions : -75 dB typical
- Carrier suppression : 65 dB typical
- Unwanted sideband suppression : 70 dB typical
- Microphone impedance : 600 Ω

RECEIVER

- Sensitivity

USB, CW, AFSK, FSK, (for 12 dB SINAD):	
0.35 μV typical (1.8–29.9999 MHz)	
1.0 μV (1.6–1.7999 MHz)	
6.3 μV (0.5–1.5999 MHz)	
AM (for 10 dB S/N):	
2.2 μV typical (1.8–29.9999 MHz)	
6.3 μV (1.6–1.7999 MHz)	
32 μV (0.5–1.5999 MHz)	
- Spurious response rejection : 80 dB typical
(1.6–29.9999 MHz)
- Audio output power : 4.0 W (at 10% distortion
with a 4 Ω load)
- Audio impedance : 4 Ω
(4 to 8 Ω acceptable)
- Clarity variable range : ± 150 Hz

All stated specifications are subject to change without notice or obligation.

Options

MN-100
ANTENNA MATCHER



Matches the transceiver to a dipole antenna. Covers all HF bands from 1.5 to 30 MHz. 8 m (26 ft.) \times 2 antenna wires are included.

MN-100L
ANTENNA MATCHER



Matches the transceiver to a long wire antenna. Covers all HF bands from 1.5 to 30 MHz. 15 m (49 ft.) \times 1 antenna wire are included.

AH-710
FOLDED DIPOLE ANTENNA

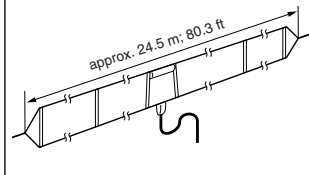

Covers from 1.9 to 30 MHz band. Has an SO-239 connector. Easy to assemble (non-kink construction).

AT-130
AUTOMATIC ANTENNA TUNER

Matches the transceiver to a long wire antenna with a minimum of insertion loss.

OPC-566
CONTROL CABLE

The optional control cable for AT-130.

Approved Icom optional equipment is designed for optimal performance when used with an Icom transceiver. Icom is not responsible for the destruction or damage to an Icom transceiver in the event the Icom transceiver is used with equipment that is not manufactured or approved by Icom.

Count on us!

