

VHF FM TRANSCEIVER

TK-7180/7189/7180H

UHF FM TRANSCEIVER

TK-8180/8189/8180H

SERVICE MANUAL **ADDENDUM II**

KENWOOD

Kenwood Corporation

© 2005-12 PRINTED IN JAPAN
B51-8732-10 (N) PDF

MPT Trunking Version

Use this service manual together with the following service manuals.

- TK-7180 service manuals (B51-8691-00, B51-8712-00 and B51-8713-00)
- TK-7189 service manual (B51-8713-00)
- TK-7180H service manual (B51-8736-00)
- TK-8180 service manuals (B51-8692-00, B51-8702-00, B51-8712-00 and B51-8714-00)
- TK-8189 service manual (B51-8714-00)
- TK-8180H service manual (B51-8735-00)

CONTENTS

SYSTEM SET-UP	2
REALIGNMENT	3
INSTALLATION	5
ADJUSTMENT	12
TK-7180/7189/7180H	17
TK-8180/8189/8180H	23



This product uses Lead Free solder.

SYSTEM SET-UP

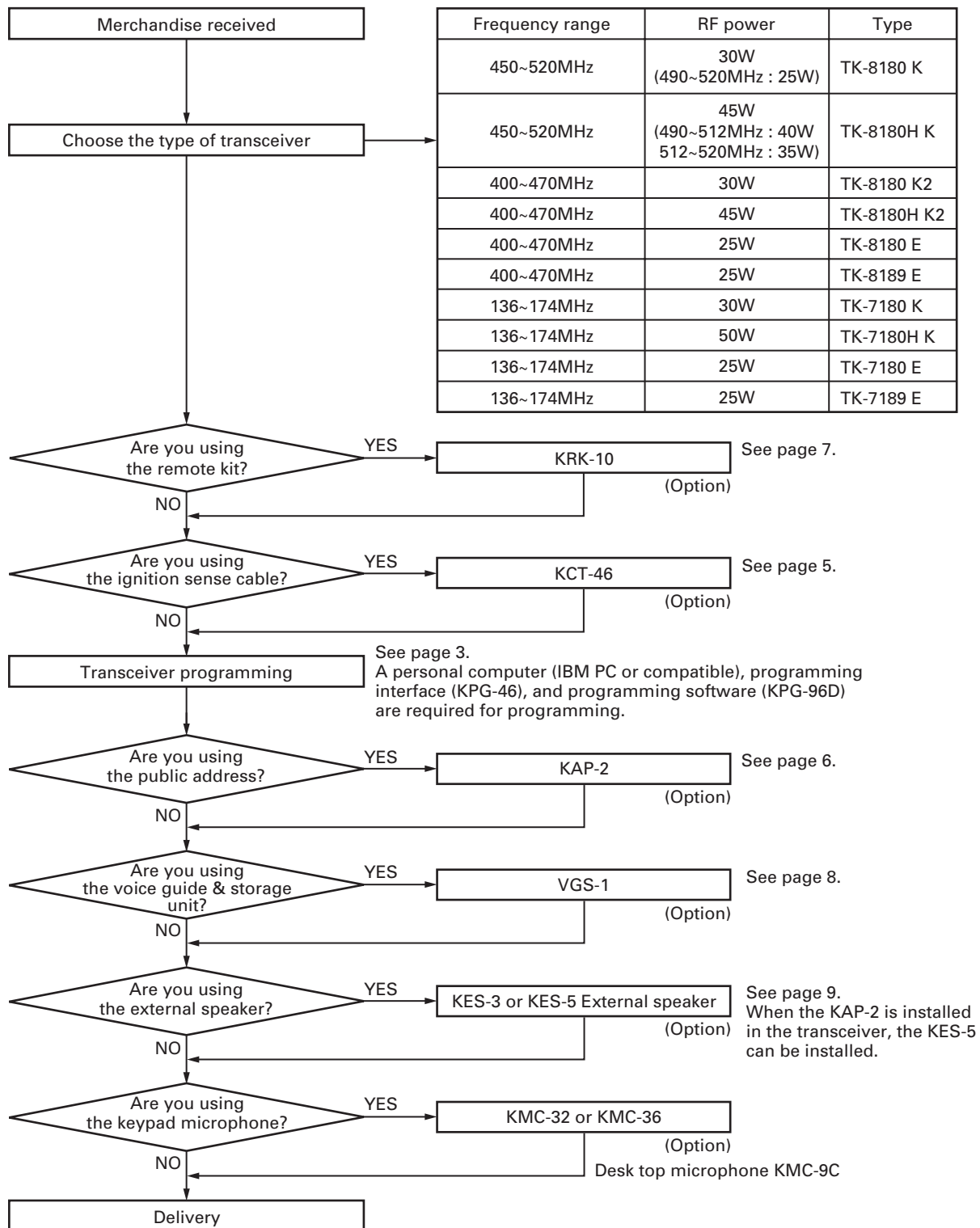

REALIGNMENT

1. Modes

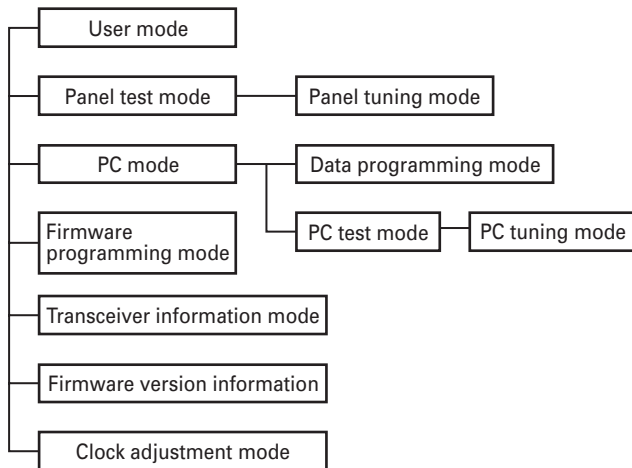

Mode	Function
User mode	For normal use.
Panel test mode	Used by the dealer to check the fundamental characteristics.
Panel tuning mode	Used by the dealer to tune the transceiver.
PC mode	Used for communication between the transceiver and PC (IBM compatible).
Data programming mode	Used to read and write frequency data and other features to and from the transceiver.
PC test mode	Used to check the transceiver using the PC. This feature is included in the FPU. See panel test.
PC tuning mode	Used to tune the transceiver using the PC. This feature is included in the FPU. See panel tuning.
Firmware programming mode	Used when changing the main program of the flash memory.
Transceiver information mode	Used to confirm the MPT ESN, firmware version and transceiver serial number.
Firmware version information	Used to confirm the internal firmware version.
Clock adjustment mode	Used by the dealer to adjust date and time.

2. How to Enter Each Mode

Mode	Operation
User mode	Power ON
Panel test mode	[A] + Power ON
PC mode	Received commands from PC
Panel tuning mode	[Panel test mode] + [S]
Firmware programming mode	[S] + Power ON
Transceiver information mode	[B] + Power ON
Firmware version information	[▲] + Power ON
Clock adjustment mode	[C] + Power ON

3. Panel Test Mode

Setting method refer to ADJUSTMENT.

4. Panel Tuning Mode

Setting method refer to ADJUSTMENT.

5. PC Mode

5-1. Preface

The transceiver is programmed by using a personal computer, programming interface cable (KPG-46) and programming software (KPG-96D).

The programming software can be used with an IBM PC or compatible. Figure 1 shows the setup of an IBM PC for programming.

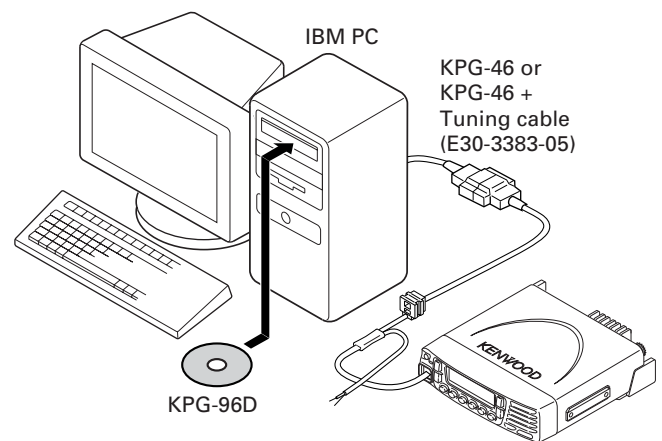

Fig. 1

REALIGNMENT

5-2. Connection procedure

1. Connect the transceiver to the personal computer with the interface cable.
2. When the POWER switch on, user mode can be entered immediately. When PC sends command the transceiver enter PC mode, and "PROGRAM" is displayed on the LCD.
When data transmitting from transceiver, the red LED is lights.
When data receiving to transceiver, the green LED is lights.

Note:

The data stored in the personal computer must match model type, when it is written into the flash memory.

5-3. KPG-46 description

(PC programming interface cable: Option)

The KPG-46 is required to interface the transceiver to the computer. It has a circuit in its D-sub connector (25-pin) case that converts the RS-232C logic level to the TTL level.

The KPG-46 connects the modular microphone jack of the transceiver to the computers RS-232C serial port.

5-4. Programming software KPG-96D description

The KPG-96D is the programming software for the transceiver. This software runs under MS-Windows 98, ME, Windows 2000 or XP on an IBM-PC or compatible machine.

The data can be input to or read from the transceiver and edited on the screen. The programmed or edited data can be printed out. It is also possible to tune the transceiver.

6. Firmware Programming Mode

6-1. Preface

Flash memory is mounted on the transceiver. This allows the transceiver to be upgraded when new features are released in the future. (For details on how to obtain the firmware, contact Customer Service.)

6-2. Connection procedure

Connect the transceiver to the personal computer (IBM PC or compatible) with the interface cable (KPG-46). (Connection is the same as in the PC Mode.)

Note:

You can only program firmware from the 8-pin microphone connector on the front panel. Using the 25-pin logic interface on the rear panel will not work.

6-3. Programming

1. Start up the firmware programming software (Fpro.exe).
2. Set the communications speed (normally, 115200 bps) and communications port in the configuration item.

3. Set the firmware to be updated by File name item.
4. Turn the transceiver power ON with the [S] key held down. Then, the orange LED on the transceiver lights and "PROG 115200" is displayed.
5. Check the connection between the transceiver and the personal computer, and make sure that the transceiver is in the Program mode.
6. Press write button in the window. When the transceiver starts to receive data, the [PG] display is blinking.
7. If writing ends successfully, the checksum is calculated and a result is displayed.
8. If you want to continue programming other transceivers, repeat steps 4 to 7.

Note:

This mode cannot be entered if the Firmware Programming mode is set to Disable in the Programming software.

6-4. Function

1. If you press the [■] key while "PROG 115200" is displayed, the display changes to "PROG 19200" (The LED blinks green) to indicate that the write speed is low speed (19200 bps). If you press the [■] key again while "PROG 19200" is displayed, the display changes to "PROG 38400" (The LED lights red and orange alternatively). If you press the [■] key again while "PROG 38400" is displayed, the display changes to "PROG 57600" (The LED blinks orange). If you press the [■] key again while "PROG 57600" is displayed, the display returns to "PROG 115200" (The LED lights orange).
2. If you press the [▲] key while "PROG 115200" is displayed, the checksum is calculated, and a result is displayed. If you press the [▲] key again while the checksum is displayed, "PROG 115200" is redisplayed.

Note:

Normally, write in the high-speed mode.

7. Transceiver Information Mode

Use this function to confirm the MPT ESN, firmware version and transceiver serial number.

1. Press and hold the [B] key for 2 seconds while turning the transceiver power ON.
2. Use the [↗] and [↘] keys to select the confirmation items.
3. To exit the transceiver information mode, turn the transceiver power OFF.

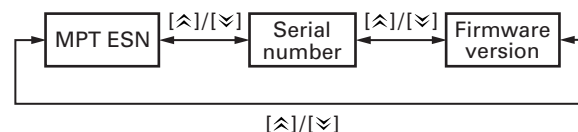

REALIGNMENT / INSTALLATION

8. Firmware Version Information

Press and hold the [△] key while turning the transceiver power ON and then keep pressing and holding the [△] key, the firmware version information appears on the LCD.

9. Clock Adjustment Mode

9-1. Flow chart of operation

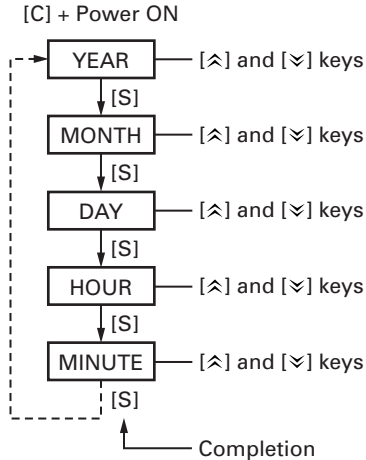

INSTALLATION

1. Ignition Sense Cable (KCT-46 : Option)

The KCT-46 is an optional cable for enabling the ignition function. The ignition function lets you turn the power to the transceiver on and off with the car ignition key.

1-1. Connecting the KCT-46 cable to the transceiver

1. Open the KCT-46 fuse holder and insert a mini blade fuse (3A). (①)
2. While holding a clear protective cover, remove the black cap at the end of the yellow cable (ignition sense cable) of the transceiver. (②)
3. Connect the plug of the KCT-46 to the yellow cable terminal of the transceiver. (③)
4. Connect the other end of the KCT-46 to the ignition line of the car. (④)

Note: You must setup using the KPG-96D.

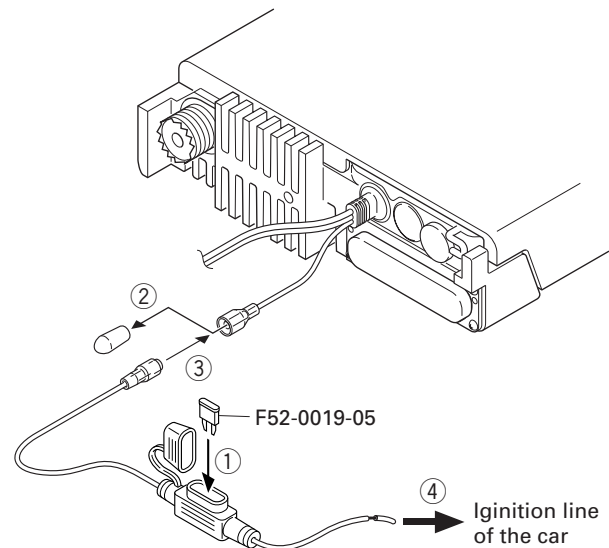

Fig. 1

INSTALLATION

2. Horn Alert/P.A. Relay Unit (KAP-2 : Option)

The Horn alert (max. 2A drive), Public address and External speaker function are enabled by installing the KAP-2 in the transceiver.

2-1. Installing the KAP-2 unit in the transceiver (The kit A is not used in the KAP-2 accessories)

1. Remove the cabinet, top packing and shielding plate of the transceiver.
2. Set the KAP-2 relay unit jumper pins according to the purpose of use.
3. Remove the 6-pin jumper connector inserted in the TX-RX unit (B/3) connector (CN428). (①)
4. Insert one side of the lead wire with connector (E37-1114-05) into the relay unit connector (CN3) (②) and the other side into the TX-RX unit (B/3) connector (CN428) (③).

5. Place the relay unit at the position shown in Figure 2-2 and secure it to the chassis with a screw.
6. Remove the cap on the rear of the chassis by pushing it from the inside with your finger. (④)
7. Pass the 6-pin connector of the cable (E37-1113-05) through the chassis hole (⑤) and insert the bush into the chassis hole.
8. Rotate the bush of the cable 90 degrees counterclockwise as viewed from the rear of the chassis. (⑥)
9. Insert the 6-pin connector of the cable into the connector (CN2) of the KAP-2 relay unit. (⑦)

Note : You must setup using the KPG-96D.

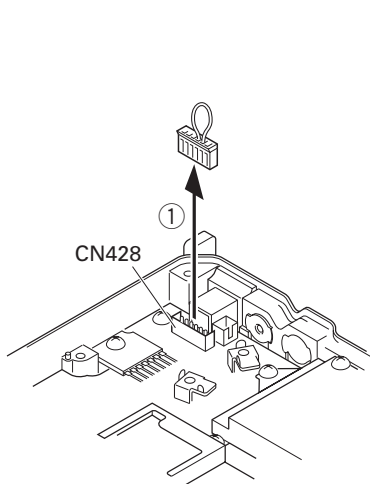

Fig. 2-1

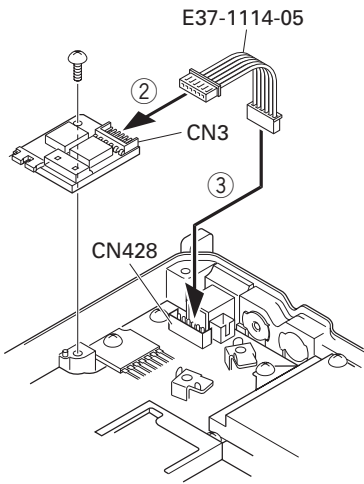

Fig. 2-2

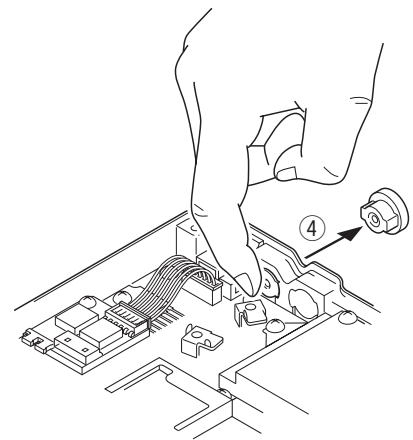

Fig. 2-3

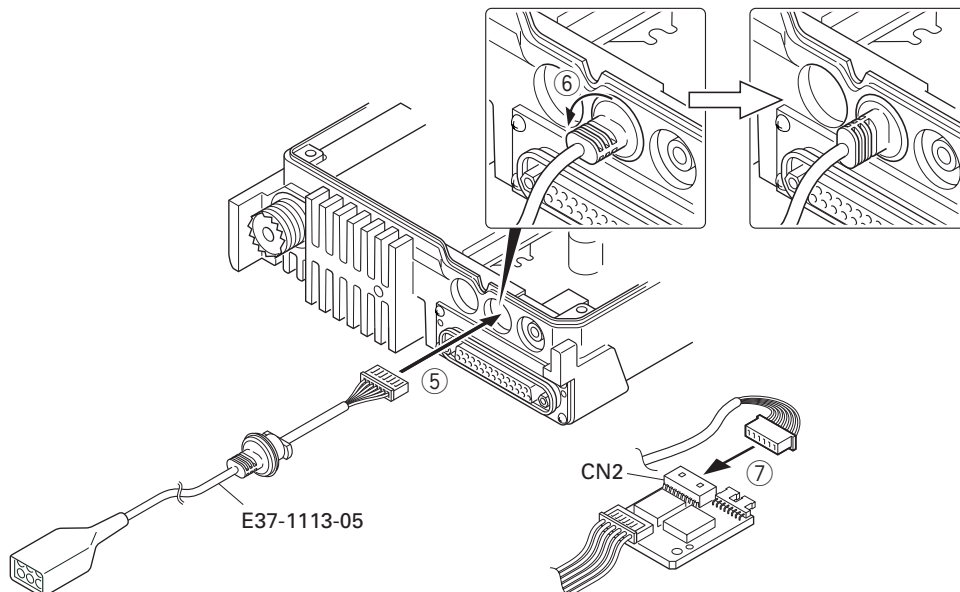

Fig. 2-4

INSTALLATION

3. Control Head Remote Kit (KRK-10 : Option)

The KRK-10 remote kit is used to remotely operate the transceiver.

3-1. Installing the KRK-10 kit to the transceiver

1. Remove the front panel from the transceiver.
2. Install the KRK-10 main panel onto the transceiver.
3. Install the KRK-10 rear panel onto the front panel.
4. Connect the KRK-10 main panel to the rear panel with the cable.

■ Remove the front panel from the transceiver

1. Lift the two tabs of the panel on the bottom of the transceiver with a flat-head screwdriver (①) and remove the panel from the chassis (②).
- Note :** Confirm that the tabs of the speaker hardware fixture and holder is securely fitted in the front panel.
2. Remove the flat cable from the connector (CN902) of the display unit of the panel. (③)
 3. Fold the black line of the flat cable (in three parts) as shown in Figure 3-2. (④, ⑤, ⑥)

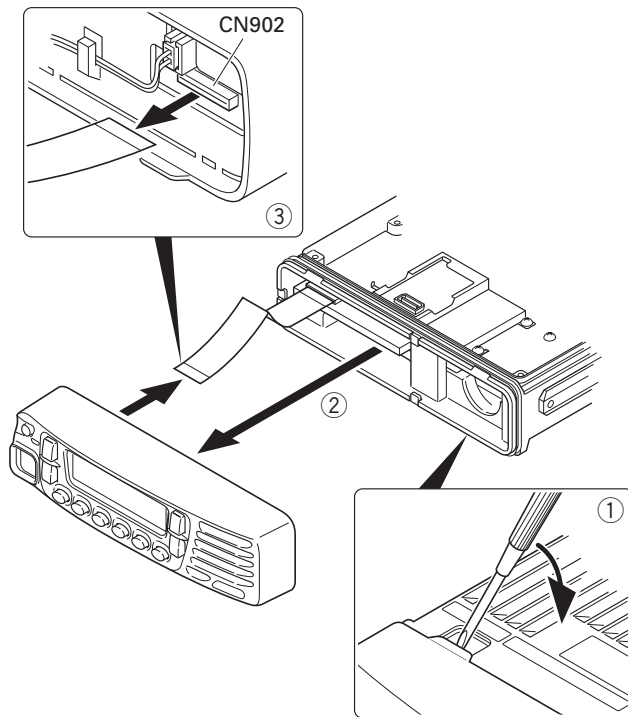

Fig. 3-1

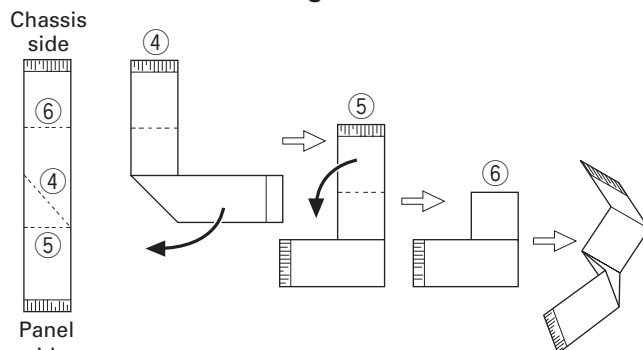

Fig. 3-2

■ Install the KRK-10 main panel onto the transceiver

4. Insert the flat cable that was removed in step 2 above into the connector (CN1) of the interface unit (A/2) of the KRK-10 main panel (A62-1101-01). (⑦)
- Note :** The terminal side of the flat cable must face down when inserting the flat cable into the connector.
5. Fit the main panel with four tabs onto the front of the chassis. (⑧)
- Note :** When installing the main panel onto the front of the chassis, hold down the flat cable with your fingers to prevent it from being caught.

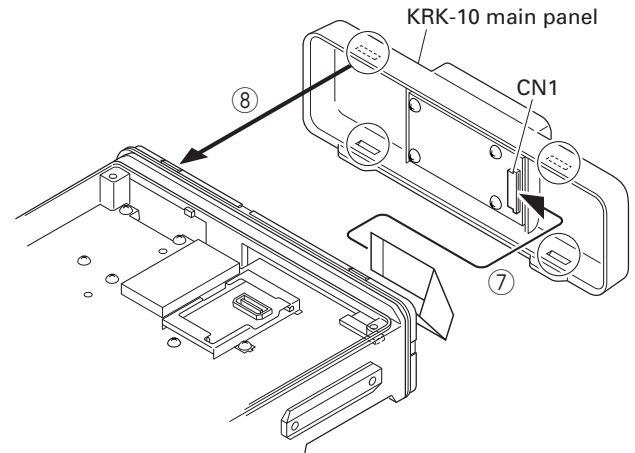

Fig. 3-3

■ Install the KRK-10 rear panel onto the front panel

6. Insert the flat cable attached to the interface unit (B/2) of the KRK-10 rear panel (A82-0056-11) into the connector (CN902) of the display unit of the panel (⑨). (The flat cable has been pre-inserted in the connector (CN2) of the rear panel at the time of shipping.)
- Note :** The terminal side of the flat cable must face down when inserting the flat cable into the connector.
7. Fit the four tabs of the rear panel into the front panel. (⑩)

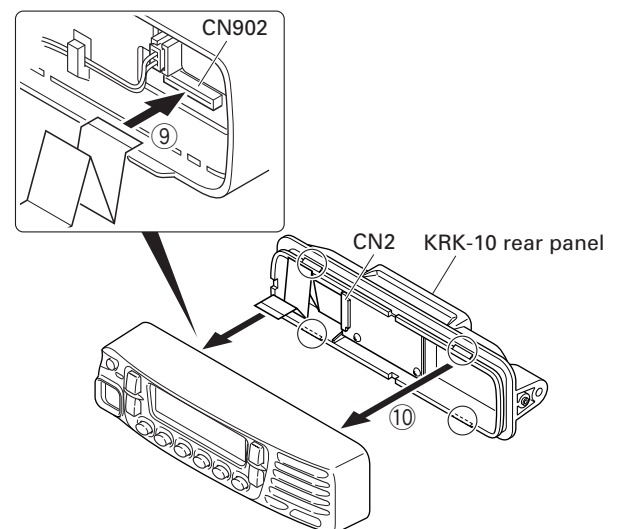

Fig. 3-4

INSTALLATION

■ Connect the KRK-10 main panel to the rear panel with the cable

8. Insert one 14-pin connector of the cable (E30-7514-15) into the connector (CN3) of the interface unit (A/2) of the main panel. (⑪)

Note : Insert the connector that has a sticker onto the cable to the connector of the main panel.

9. Secure the cable bush on the main panel and fit the waterproof packing (orange) (⑫) securely over top.

10. Install the molded cover (⑬) over the connector on the main panel and secure it with two screws (⑭).

11. Insert the other 14-pin connector of the cable into the connector (CN4) of the interface unit (B/2) of the rear panel. (⑮)

12. Secure the cable bush on the rear panel and fit the waterproof packing (orange) (⑯) securely over top.

13. Install the molded cover (⑰) over the connector on the rear panel and secure it with two screws (⑱).

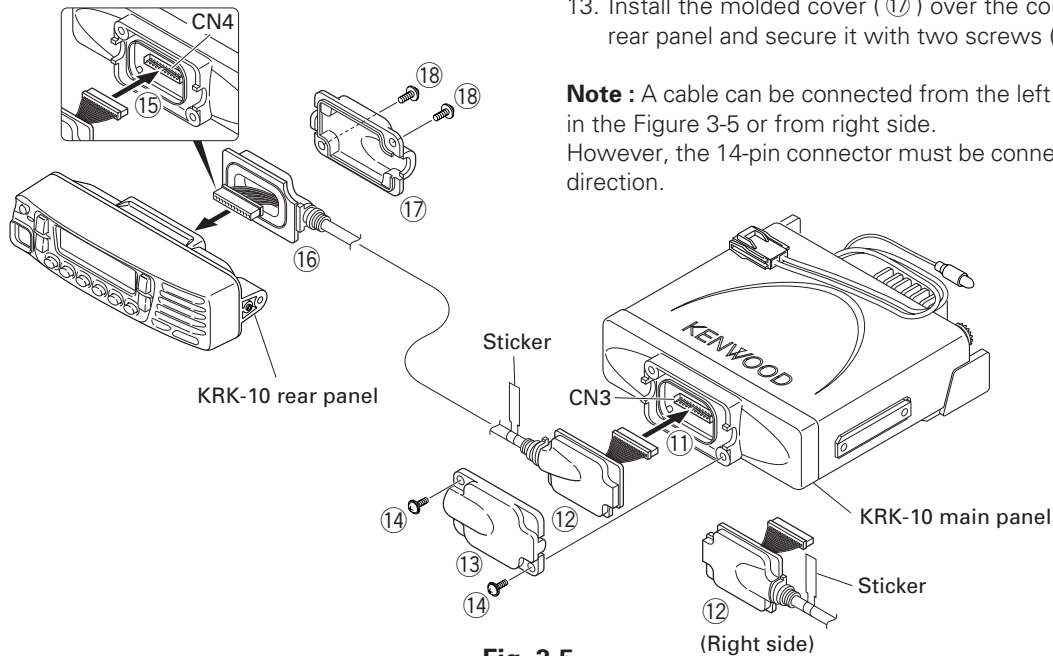

Fig. 3-5

4. Voice Guide & Storage Unit (VGS-1 : Option)

4-1. Installing the VGS-1 unit in the transceiver

1. Remove the cabinet, top packing and shielding plate of the transceiver.

2. Attach two cushions to VGS-1 as shown in Figure 4. (①)

Note : Be sure not to cover the connector with the bottom cushion.

3. Insert the VGS-1 connector (CN1) into the TX-RX unit (B/3) connector (CN403). (②)

Note : You must setup using the KPG-96D.

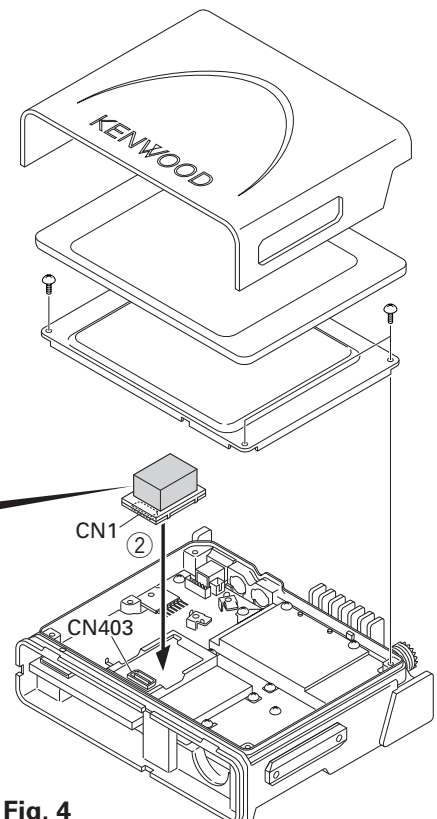
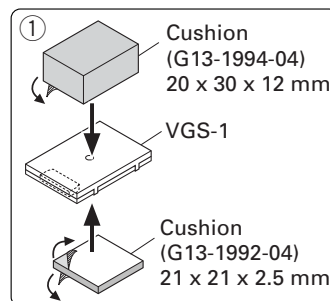

Fig. 4

INSTALLATION

5. External Speaker (Option)

5-1. KES-3

The KES-3 is an external speaker for the 3.5-mm-diameter speaker jack.

■ Connection Procedure

1. Connect the KES-3 to the 3.5-mm-diameter speaker jack on the rear of the transceiver.

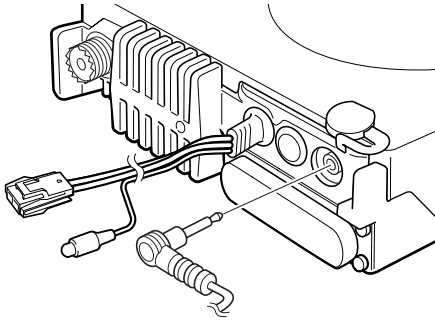

Fig. 5-1

5-2. KES-5

External speaker KES-5 can be installed for KAP-2. If KES-5 is installed, it can be set by changing the CN1 short pin from pins 4 and 5 to pins 5 and 6 on the KAP-2.

KAP-2 CN1 Connect	Set Up
4-5	INT. SP or KES-3
5-6	KES-5

When you use the KES-5, plug the short pin to pins 5 and 6 on the KAP-2.

When you use the INT. SP or KES-3, plug the short pin to pins 4 and 5 on the KAP-2.

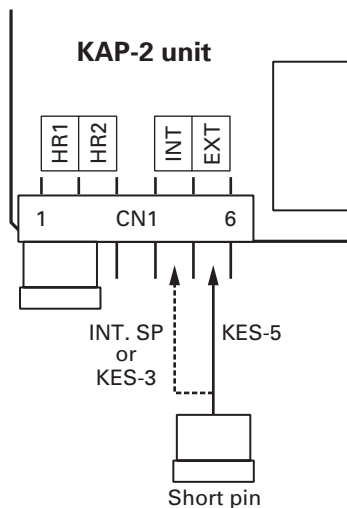

Fig. 5-2

■ Connection Procedure

Insert the crimp terminal into the Square plug supplied with the KAP-2.

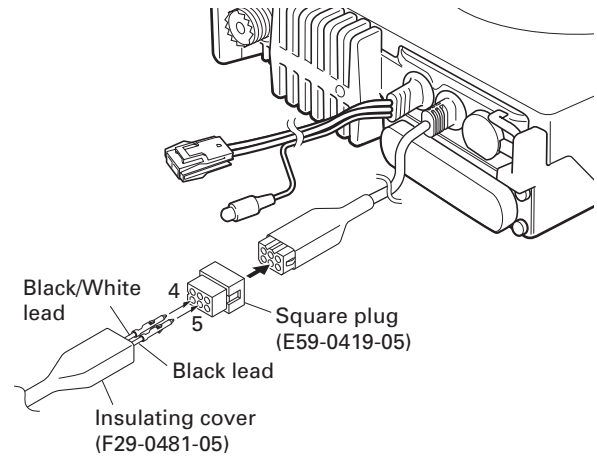
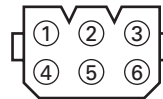

Fig. 5-3

■ KAP-2 Cable (E37-1113-05) 6-pin Connector



Pin No.	Color	Name
1	Red	HR2
2	Blue	GND
3	Yellow	OSP
4	Green	ESP
5	Brown	GND
6	Black	HR1

INSTALLATION

6. Voice Scrambler Board Connection

1. Remove the front panel from the transceiver.
2. Solder each lead of the scrambler board to a necessary location of each landing on the component side of the TX-RX unit (B/3).
3. Wrap the scrambler board in a cushion and install it on the front of the chassis as shown in Figure 6-2.

Note : You must setup using the KPG-96D.

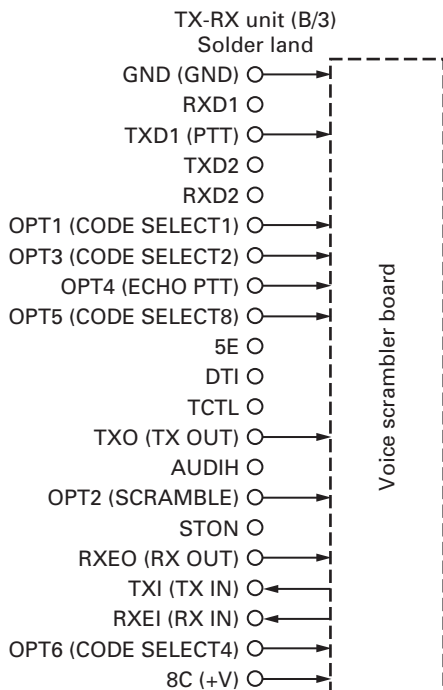

Fig. 6-1

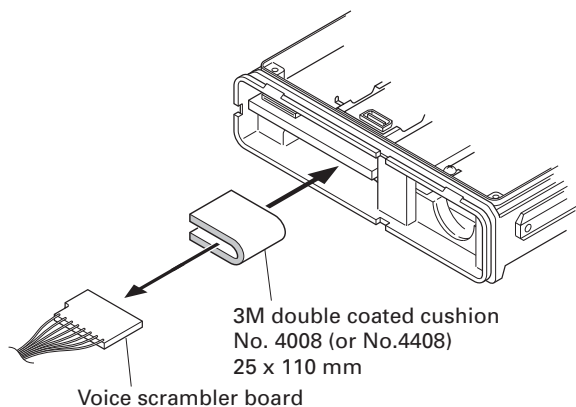

Fig. 6-2

7. GPS Receiver Connection

7-1. Installing the GPS receiver

1. Remove the cabinet, top packing and shielding plate of the transceiver.
2. Remove the front panel from the transceiver.
3. Attach two cushions to the top of the GPS receiver.
4. Attach the GPS receiver to the shield case with two cushions as shown in Figure 7-2.
5. Solder each lead of the GPS receiver to a necessary location of each landing on the component side of the TX-RX unit (B/3).
6. Place the GPS antenna cable in the hollow at the rear of the chassis. (Fig. 7-2 ①)

Note : If the GPS receiver is installed, cut the base of the convex tab of the top packing with a pair of nippers, or similar tool. (Fig. 7-3 ②)

If the convex tab of the top packing is cut off, the water proofing property is no longer guaranteed.

Note : You must setup using the KPG-96D.

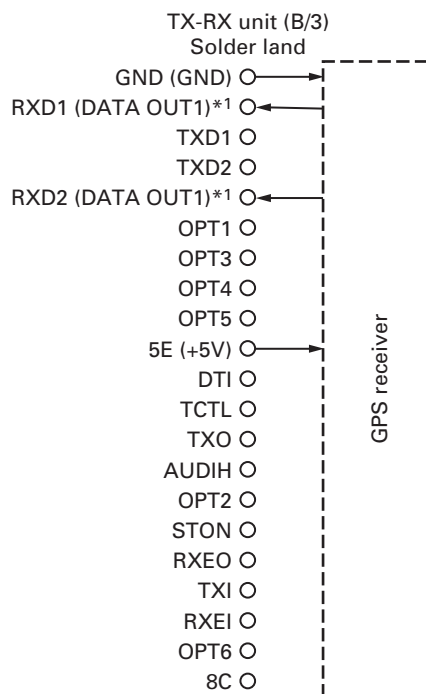

*1 : Depending on the connected optional accessory, the DATA OUT1 may connect to either RXD1 or RXD2.

Fig. 7-1

INSTALLATION

3M Double coated cushion
No. 4016 (or No. 4416)
30 x 25 mm

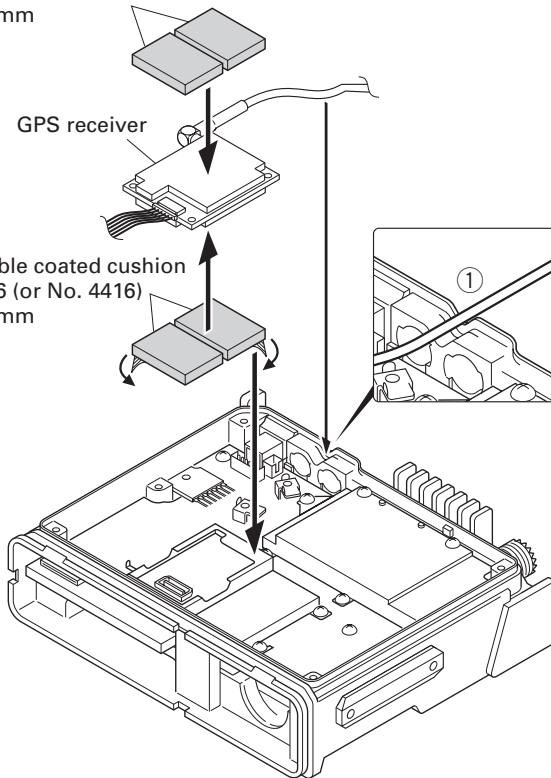

Fig. 7-2

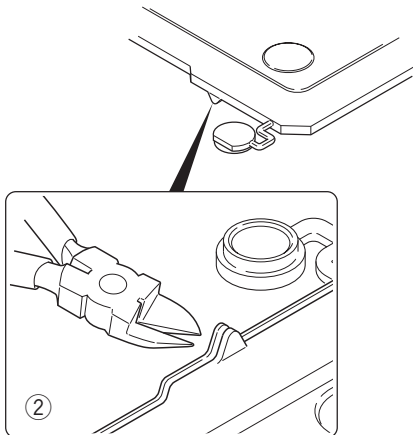

Fig. 7-3

7-2. Installing the GPS receiver together with the VGS-1

1. Remove the cabinet, top packing and shielding plate of the transceiver.
2. Remove the front panel from the transceiver.
3. Attach a cushion to the bottom of the VGS-1 as shown in Figure 7-5.

Note : Be sure not to cover the connector with the cushion.

4. Insert the VGS-1 connector (CN1) into the TX-RX unit (B/3) connector (CN403).
5. Perform step 3 to 6 of "7-1. Installing the GPS receiver" described on page 10.

Note : You must setup using the KPG-96D.

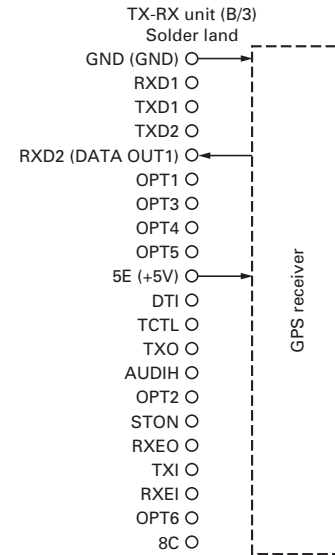

Fig. 7-4

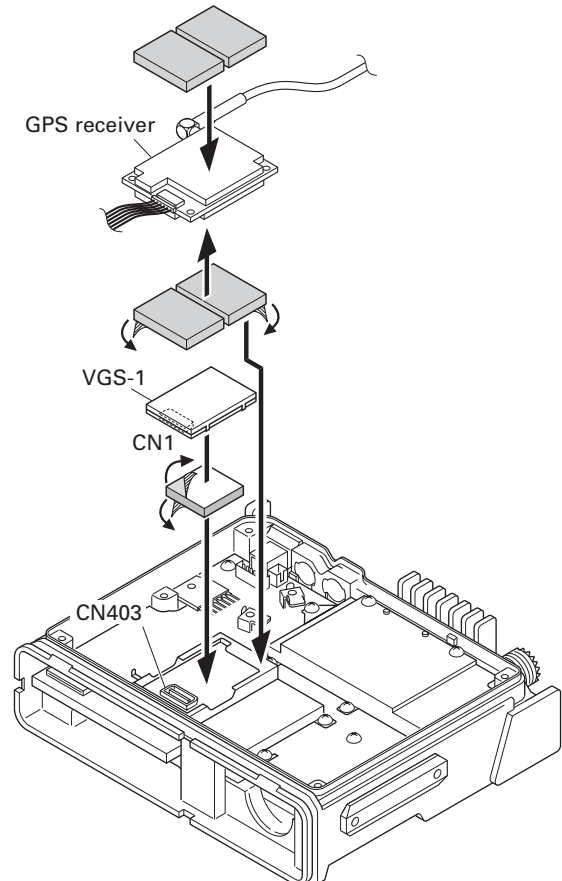
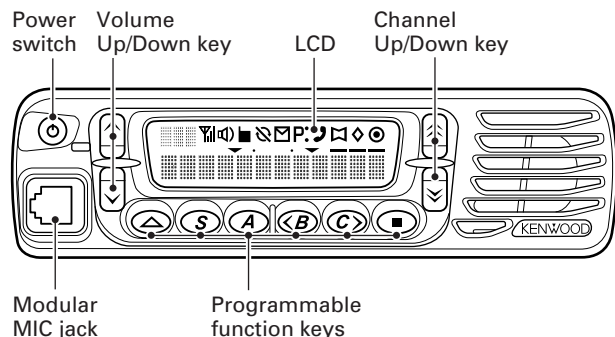

Fig. 7-5

ADJUSTMENT

Controls



Panel Test Mode

■ Test mode operation features

This transceiver has a test mode. **To enter test mode, press and hold the [A] key while turning the transceiver power ON. Before the transceiver enters test mode, the frequency version information appears on the LCD momentarily.** Test mode can be inhibited by programming. To exit test mode, turn the transceiver power OFF. The following functions are available in test mode.

■ Key operation

Key	"FNC" not appears	
	Function	Display
[S]	Shifts to Panel tuning mode	-
[A]	Function on	"FNC" appears
[B]	MSK 1200bps and 2400bps	2400bps : icon appears
[C]	Test signaling CH up	Signaling No.
[↗]/[↘]	Test frequency CH up/down	Channel No.
[^]/[v]	Volume up/down	-
[△]	Squelch on/off	
[■]	Narrow/Wide	Narrow : "n" Wide : "w"
[0] to [9] and [#], [*] *1	Use as the DTMF keypad. If a key is pressed during transmission, the DTMF corresponding to the key that was presses is sent.	-
Microphone key		
[PTT]	Transmit	-
[0] to [9] and [A], [B], [C], [D], [#], [*]	Use as the DTMF keypad. If a key is pressed during transmission, the DTMF corresponding to the key that was presses is sent.	-

Key	"FNC" appears	
	Function	Display
[S]	High power / Low power	Low : icon appears
[A]	Function off	-
[B]	Compander on/off	On : icon appears
[C]	Beat shift on/off	On : icon appears
[↗]/[↘]	Function off	-
[^]/[v]	Function off	-
[△]	Squelch level 0	On : P icon appears
[■]	LCD all lights	LCD all point appears
[0] to [9] and [#], [*] *2	Function off	-
Microphone key		
[PTT]	Transmit	-
[0] to [9] and [A], [B], [C], [D], [#], [*]	Function off	-

*2 : TK-7189 and TK-8189 models only

Note:

If a [S], [A], [B], [C] key is pressed during transmission, the DTMF corresponding to the key that was pressed is sent.

• LED indicator

Red LED Lights during transmission.
Green LED Lights when there is carrier.

• Sub LCD indicator

"FNC" Appears at function on.

• LCD display in panel test mode

n : Narrow Channel No. Signaling No.

*1 : TK-7189 and TK-8189 models only

ADJUSTMENT

■ Frequency and Signaling

The transceiver has been adjusted for the frequencies shown in the following table. When required, readjust them following the adjustment procedure to obtain the frequencies you want in actual operation.

• Test frequency

136~174MHz (TK-7180 K,E/7189 E/7180H K)

CH	RX (MHz)	TX (MHz)
1	155.05000	155.10000
2	136.05000	136.10000
3	173.95000	173.90000
4	155.00000	155.00000
5	155.20000	155.20000
6	155.40000	155.40000
7	177.95000	177.90000
8~16	-	-

450~520MHz (TK-8180 K/8180H K)

CH	RX (MHz)	TX (MHz)
1	485.05000	485.10000
2	450.05000	450.10000
3	519.95000	519.90000
4	485.00000	485.00000
5	485.20000	485.20000
6	485.40000	485.40000
7~16	-	-

400~470MHz (TK-8180 K2,E/TK-8189 E/8180H K2)

CH	RX (MHz)	TX (MHz)
1	435.05000	435.10000
2	400.05000	400.10000
3	469.95000	469.90000
4	435.00000	435.00000
5	435.20000	435.20000
6	435.40000	435.40000
7~16	-	-

• Test signaling

No.	RX	TX
1	None	None
2	None	100Hz Square Wave
3	Skip	
4	QT : 67.0Hz	QT : 67.0Hz
5	QT : 151.4Hz	QT : 151.4Hz
6	QT : 210.7Hz	QT : 210.7Hz
7	QT : 254.1Hz	QT : 254.1Hz
8	DQT : D023N	DQT : D023N
9	DQT : D754I	DQT : D754I
10	Skip	
11	None	DTMF Code 9
12	Skip	
13	Skip	
14	None	Single Tone : 1000Hz
15	Skip	
16	None	MSK
17	MSK : Data : 0x230960C6AAAA CRC : 0xC4D7	MSK : Data : 0x230960C6AAAA CRC : 0xC4D7

Panel Tuning Mode

■ Preparations for tuning the transceiver

Before attempting to tune the transceiver, connect the unit to a suitable power supply.

Whenever the transmitter is turned, the unit must be connected to a suitable dummy load (i.e. power meter).

The speaker output connector must be terminated with a 4Ω dummy load and connected to an AC voltmeter and an audio distortion meter or a SINAD measurement meter at all times during tuning.

■ Transceiver tuning

(To place transceiver in tuning mode)

Press [S] key, now in tuning mode. Use [B] key to write tuning data through tuning modes, and [↗]/[↘] to adjust tuning requirements (1 to 256 appears on LCD).

Use [C] key to select the adjustment item through tuning modes. Use [A] key to adjust 3 or 5 reference level adjustments, and use [■] key to switch between Wide/Narrow.

Channel appears on LCD. Set channel according to tuning requirements.

• LCD display in panel tuning mode

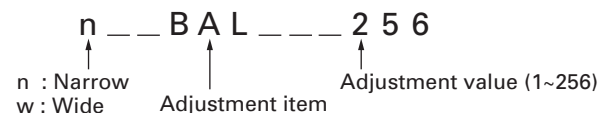

ADJUSTMENT

■ Key operation

Key	Function	
	Push	Hold (1 second)
[S]	End of panel tuning mode	-
[A]	To enter 3 or 5 reference level adjustments	-
[B]	Writes the adjustment value	-
[C]	Go to next adjustment item	Back to last adjustment item
[↗]/[↘]	Adjustment value up/down	Continuation up/down
[^]/[v]	Volume level up/down	Continuation up/down
[△]	Squelch on/off	-
[■]	Selects Narrow, Wide	-

■ 3 or 5 reference level adjustments frequency

136~174MHz (TK-7180 K,E/7189 E/7180H K)

Tuning point	RX (MHz)	TX (MHz)
Low	136.05000	136.10000
Low'	145.55000	145.60000
Center	155.05000	155.10000
High'	164.55000	164.60000
High	173.95000	173.90000

450~520MHz (TK-8180 K/8180H K)

Tuning point	RX (MHz)	TX (MHz)
Low	450.05000	450.10000
Low'	467.55000	467.60000
Center	485.05000	485.10000
High'	502.55000	502.60000
High	519.95000	519.90000

400~470MHz (TK-8180 K2,E/TK-8189 E/8180H K2)

Tuning point	RX (MHz)	TX (MHz)
Low	400.05000	400.10000
Low'	417.55000	417.60000
Center	435.05000	435.10000
High'	452.55000	452.60000
High	469.95000	469.90000

■ Adjustment item and Display

(*** : 1~256, Only MSK : 1~64)

Order	Adjustment item	Display
1	Frequency	FREQ ***
2	Shift 1	SHFT1 ***
3	Shift 2	SHFT2 ***
4	Max high power	MHPWR ***
5	Max low power	MLPWR ***
6	High power	HPWR ***
7	Low power	LPWR ***
8	DQT balance	BAL ***
9	Max deviation	DEV ***
10	QT deviation	QT ***
11	DQT deviation	DQT ***
12	DTMF deviation	DTMF ***
13	MSK deviation	MSK **
14	Tone deviation	TONE ***
15	Sensitivity 1	SENS1 ***
16	Squelch	SQL ***
17	Low RSSI	LRSSI ***
18	Squelch tight	SQLT ***
19	High RSSI	HRSSI ***

ADJUSTMENT

Flow chart

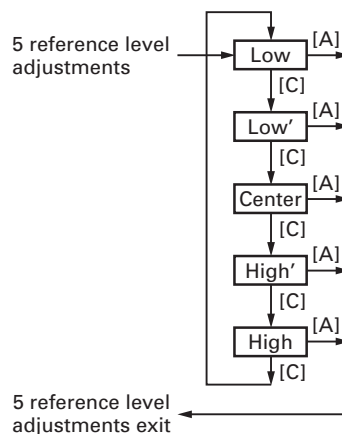
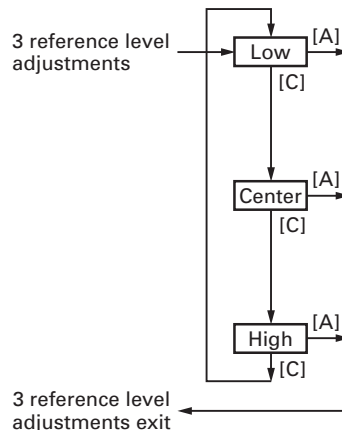
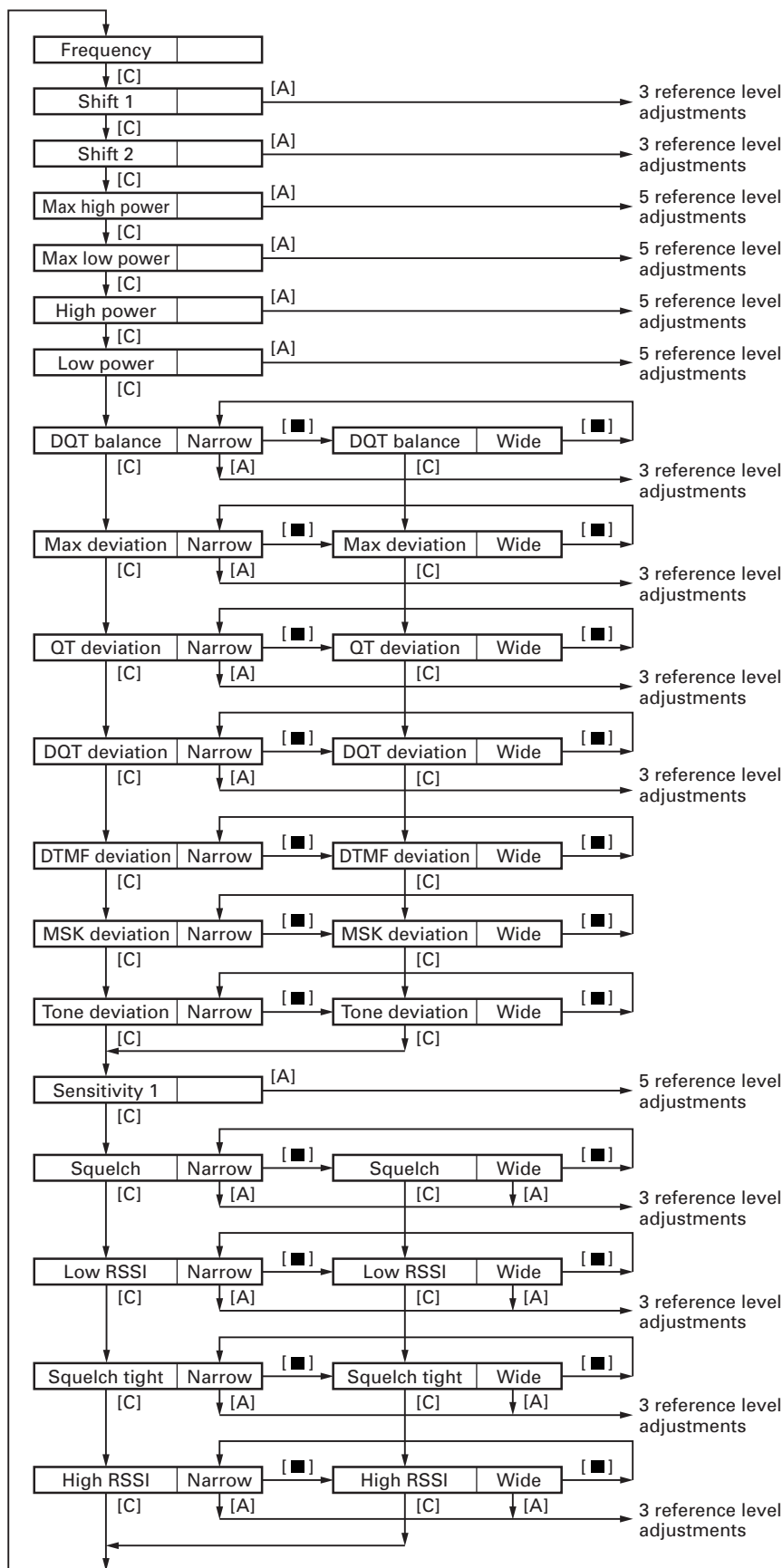

ADJUSTMENT

Test Equipment Required for Alignment

Test Equipment	Major Specifications	
1. Standard Signal Generator (SSG)	Frequency Range	136 to 174MHz (TK-7180/7189/7180H), 400 to 520MHz (TK-8180/8189/8180H)
	Modulation	Frequency modulation and external modulation
	Output	0.1μV to greater than 1mV
2. Power Meter	Input Impedance	50Ω
	Operation Frequency	136 to 174MHz or more (TK-7180/7189/7180H), 400 to 520MHz or more (TK-8180/8189/8180H)
	Measurement Capability	Vicinity of 50W
3. Deviation Meter	Frequency Range	136 to 174MHz (TK-7180/7189/7180H), 400 to 520MHz (TK-8180/8189/8180H)
4. Digital Volt Meter (DVM)	Measuring Range	1 to 20V DC
	Input Impedance	High input impedance for minimum circuit loading
5. Oscilloscope		DC through 30MHz
6. High Sensitivity Frequency Counter	Frequency Range	10Hz to 600MHz
	Frequency Stability	0.2ppm or less
7. Ammeter		13A or more
8. AF Volt Meter (AF VTVM)	Frequency Range	50Hz to 10kHz
	Voltage Range	3mV to 3V
9. Audio Generator (AG)	Frequency Range	50Hz to 5kHz
	Output	0 to 1V
10. Distortion Meter	Capability	3% or less at 1kHz
	Input Level	50mV to 10Vrms
11. Voltmeter	Measuring Range	10 to 1.5V DC or less
	Input Impedance	50kΩ/V or greater
12. 4Ω Dummy Load		Approx. 4Ω, 20W
13. Regulated Power Supply		13.6V (K,K2), 13.2V (E), approx. 20A (adjustable from 9 to 20V) Useful if ammeter equipped

Test cable for microphone input (E30-3360-08)

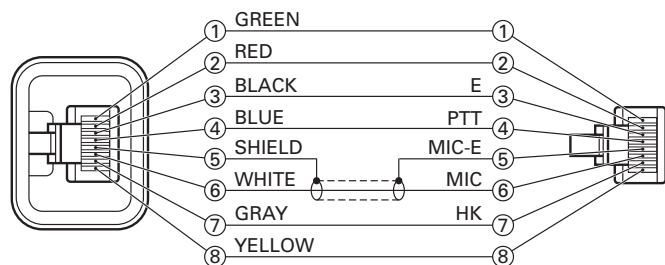

Tuning cable (E30-3383-05)

Adapter cable (E30-3383-05) is required for injecting an audio if PC tuning is used. See "PC Mode" section for the connection.

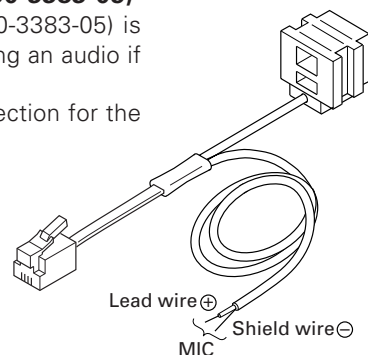

MIC connector (Front panel view)

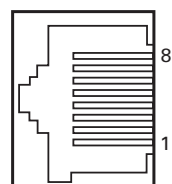

- 1 : BLC
- 2 : +B
- 3 : GND
- 4 : PTT/TXD
(PC serial data from radio)
- 5 : MICE
- 6 : MIC
- 7 : HOOK/RXD
(PC serial data to radio)
- 8 : DM

Check Jig for the VGS-1

KENWOOD part No. : W05-1127-00

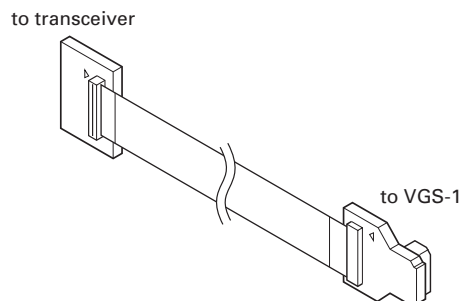

ADJUSTMENT

TK-7180/7189/7180H Common Section

Item	Condition	Measurement			Adjustment			Specifications/Remarks
		Test-equipment	Unit	Terminal	Unit	Parts	Method	
1. Setting	1) Power supply voltage DC power supply terminal : 13.6V K , 13.2V E 2) SSG standard modulation [Wide] MOD : 1kHz, DEV : 3kHz [Narrow] MOD : 1kHz, DEV : 1.5kHz							
2. VCO lock voltage • RX	[Panel test mode] 1) CH-Sig : 3-1	Power meter	Rear panel	ANT	TX-RX (B/3)	TC301	8.1V	±0.1V
	2) CH-Sig : 2-1	DVM	TX-RX (B/3)	CV			Check	2.0V±0.5V
	[Panel tuning mode] LPWR* 3) CH-Sig : 3-1 PTT : ON				TX-RX (B/3)	TC302	8.1V	±0.1V
	4) CH-Sig : 2-1 PTT : ON						Check	2.0V±0.5V

* TX can be continued on unlock condition in panel tuning mode.

TK-7180/7189/7180H Transmitter Section

Item	Condition	Measurement			Adjustment			Specifications/Remarks
		Test-equipment	Unit	Terminal	Unit	Parts	Method	
1. Frequency adjust	1) Adj item : [FREQ] Adjust : [***] PTT : ON	f. counter	Rear panel	ANT	Front panel	[↗],[↘]	Center frequency ±50Hz	Note : After replacing the VCXO (X301) align frequency.
2. Frequency shift 1 adjust	1) Adj item : [SHFT1] Adjust : [***] 2) Adj item : [L SHFT1] → [C SHFT1] → [H SHFT1] Adjust : [***] PTT : ON						[L SHFT1] Low frequency+1.25kHz [C SHFT1] Center frequency+1.25kHz [H SHFT1] High frequency+1.25kHz	±50Hz
3. Frequency shift 2 adjust	1) Adj item : [SHFT2] Adjust : [***] 2) Adj item : [L SHFT2] → [C SHFT2] → [H SHFT2] Adjust : [***] PTT : ON						[L SHFT2] Low frequency+2.5kHz [C SHFT2] Center frequency+2.5kHz [H SHFT2] High frequency+2.5kHz	±50Hz
4. Max high power adjust	1) Adj item : [MHPWR] Adjust : [***] 2) Adj item : [L MHPWR] → [L' MHPWR] → [C MHPWR] → [H' MHPWR] → [H MHPWR] Adjust : [***] PTT : ON	Power meter					33W TK-7180 K 28W TK-7180/7189 E 53W TK-7180H K	±3W CAUTION! Do not attempt to adjust the transceiver's transmit output power beyond its specifications. If the transceiver is adjusted beyond the specifications, it may cause deterioration of the parts reliability and the output power may be lowered suddenly and unstable. The transceiver may be also extremely hot.

ADJUSTMENT

Item	Condition	Measurement			Adjustment			Specifications/Remarks
		Test-equipment	Unit	Terminal	Unit	Parts	Method	
5. Max low power adjust	1) Adj item : [MLPWR] Adjust : [***] 2) Adj item : [L MLPWR] → [L' MLPWR] → [C MLPWR] → [H' MLPWR] → [H MLPWR] Adjust : [***] PTT : ON	Power meter	Rear panel	ANT	Front panel	[↗],[↘]	15W TK-7180 K,E /7189 E 25W TK-7180H K	±1W TK-7180 K,E/7189E ±2W TK-7180H K CAUTION! Do not attempt to adjust the transceiver's transmit output power beyond its specifications. If the transceiver is adjusted beyond the specifications, it may cause deterioration of the parts reliability and the output power may be lowered suddenly and unstable. The transceiver may be also extremely hot.
6. High power adjust	1) Adj item : [HPWR] Adjust : [***] 2) Adj item : [L HPWR] → [L' HPWR] → [C HPWR] → [H' HPWR] → [H HPWR] Adjust : [***] PTT : ON	Power meter Ammeter					30W TK-7180 K 23.5W TK-7180/7189 E 50W TK-7180H K	±1W TK-7180/7180H K ±0.5W TK-7180/7189 E 9A or less TK-7180 K,E/7189 E 13A or less TK-7180H K
7. High power check	[Panel test mode] 1) CH-Sig : 1-1 PTT : ON 2) CH-Sig : 2-1 PTT : ON 3) CH-Sig : 3-1 PTT : ON						Check	25~35W TK-7180 K 21~26W TK-7180/7189 E 45~55W TK-7180H K 9A or less TK-7180 K,E/7189 E 13A or less TK-7180H K
8. Low power adjust	1) Adj item : [LPWR] Adjust : [***] 2) Adj item : [L LPWR] → [L' LPWR] → [C LPWR] → [H' LPWR] → [H LPWR] Adjust : [***] PTT : ON				Front panel	[↗],[↘]	5.0W TK-7180 K,E /7189 E 10W TK-7180H K	±0.5W 5A or less TK-7180 K,E/7189 E 8A or less TK-7180H K
9. Low power check	[Panel test mode] 1) CH-Sig : 1-1 Set low power (Push [S]) PTT : ON 2) CH-Sig : 2-1 PTT : ON 3) CH-Sig : 3-1 PTT : ON						Check	3.5~6.5W TK-7180 K,E/7189 E 7~13W TK-7180H K 5A or less TK-7180 K,E/7189 E 8A or less TK-7180H K

ADJUSTMENT

Item	Condition	Measurement			Adjustment			Specifications/Remarks
		Test-equipment	Unit	Terminal	Unit	Parts	Method	
10. DQT balance adjust	1) Adj item : [n BAL] Adjust : [***] Deviation meter filter LPF : 3kHz HPF : OFF	Power meter Deviation meter Oscilloscope AG AF VTVM	Rear panel	ANT	Front panel	[↗],[↘]	Make the demodulation waves into square waves.	
	• Narrow		2) Adj item : [nL BAL] → [nC BAL] → [nH BAL] Adjust : [***] PTT : ON	Front panel				
• Wide	3) Adj item : [w BAL] Adjust : [***] PTT : ON							
11. Max DEV adjust	1) Adj item : [n DEV] Adjust : [***] AG : 1kHz/50mV at MIC terminal Deviation meter filter LPF : 15kHz HPF : OFF						2.10kHz (According to the larger +, -)	±0.10kHz
	• Narrow	2) Adj item : [nL DEV] → [nC DEV] → [nH DEV] Adjust : [***] PTT : ON						
• Wide	3) Adj item : [w DEV] Adjust : [***] PTT : ON						4.20kHz (According to the larger +, -)	±0.10kHz
12. MIC sensitivity check (Wide only)	[Panel test mode] 1) CH-Sig : 1-1 AG : 1kHz/5mV at MIC terminal PTT : ON						Check	2.5~3.5kHz
13. QT deviation adjust	1) Adj item : [n QT] Adjust : [***] Deviation meter filter LPF : 3kHz HPF : OFF				Front panel	[↗],[↘]	0.35kHz	±0.05kHz
	• Narrow	2) Adj item : [nL QT] → [nC QT] → [nH QT] Adjust : [***] PTT : ON						
• Wide	3) Adj item : [w QT] Adjust : [***] PTT : ON						0.75kHz	±0.10kHz
14. DQT deviation adjust	1) Adj item : [n DQT] Adjust : [***] Deviation meter filter LPF : 3kHz HPF : OFF						0.35kHz	±0.05kHz
	• Narrow	2) Adj item : [nL DQT] → [nC DQT] → [nH DQT] Adjust : [***] PTT : ON						
• Wide	3) Adj item : [w DQT] Adjust : [***] PTT : ON						0.75kHz	±0.10kHz

ADJUSTMENT

Item	Condition	Measurement			Adjustment			Specifications/Remarks
		Test-equipment	Unit	Terminal	Unit	Parts	Method	
15. DTMF deviation adjust • Narrow	1) Adj item : [n DTMF] Adjust : [***] Deviation meter filter LPF : 15kHz HPF : OFF PTT : ON	Power meter	Rear panel	ANT	Front panel	[↗],[↘]	1.5kHz	±0.1kHz
	• Wide	2) Adj item : [w DTMF] Adjust : [***] PTT : ON	Deviation meter Oscilloscope AG AF VTVM	Front panel	Modular MIC jack		3.0kHz	
16. MSK deviation adjust • Narrow	1) Adj item : [n MSK] Adjust : [**] Deviation meter filter LPF : 15kHz HPF : OFF PTT : ON						1.5kHz	±0.1kHz
	• Wide	2) Adj item : [w MSK] Adjust : [**] PTT : ON					3.0kHz	±0.1kHz
17. TONE deviation adjust • Narrow	1) Adj item : [n TONE] Adjust : [***] Deviation meter filter LPF : 15kHz HPF : OFF PTT : ON						1.5kHz	±0.1kHz
	• Wide	2) Adj item : [w TONE] Adjust : [***] PTT : ON					3.0kHz	±0.1kHz

TK-7180/7189/7180H Receiver Section

Item	Condition	Measurement			Adjustment			Specifications/Remarks
		Test-equipment	Unit	Terminal	Unit	Parts	Method	
1. Sensitivity adjust	1) Adj item : [SENS1] Adjust : [***] 2) Adj item : [L SENS1] → [L' SENS1] → [C SENS1] → [H' SENS1] → [H SENS1] Adjust : [***]	S S G AF VTVM Oscilloscope	Rear panel	ANT EXT. SP	Front panel	[↗],[↘]	Enter the following adjustment values to the transceiver by pressing [↗] and [↘] keys. [L SENS1] : 60 [L' SENS1] : 88 [C SENS1] : 109 [H' SENS1] : 159 [H SENS1] : 192 After setting the adjustment value, press [B] key. The adjustment value will be stored in memory.	Note : After replacing the EEPROM (IC401) align sensitivity.

ADJUSTMENT

Item	Condition	Measurement			Adjustment			Specifications/Remarks
		Test-equipment	Unit	Terminal	Unit	Parts	Method	
2. Sensitivity check	[Panel test mode] 1) CH-Sig : 1-1 SSG output Wide 5k : -117dBm (0.32μV) (MOD : 1kHz±3kHz) Narrow : -116dBm (0.35μV) (MOD : 1kHz±1.5kHz)	SSG AF VTVM Oscilloscope	Rear panel	ANT EXT. SP			Check	12dB SINAD or more
3. Squelch (Preset) adjust • Narrow	1) Adj item : [n SQL] Adjust : [***] SSG output : 12dB SINAD level (MOD : 1kHz±1.5kHz)						After input signal from SSG, press [B] key. That numeric will be stored in memory.	After adjusting SQL, check SQL open/close. SSG 12dB SINAD level + 4dB : Open SSG 12dB SINAD level - 6dB : Close [nC SQL] MOD 1kHz±1.5kHz [wC SQL] MOD 1kHz±3.0kHz
• Wide	2) Adj item : [nL SQL] → [nC SQL] → [nH SQL] Adjust : [***] 3) Adj item : [w SQL] Adjust : [SSS] SSG output : 12dB SINAD level (MOD : 1kHz±3.0kHz)							
• Wide	4) Adj item : [wL SQL] → [wC SQL] → [wH SQL] Adjust : [***]							
4. Low RSSI adjust • Narrow	1) Adj item : [n LRSSI] Adjust : [***] SSG output : 12dB SINAD level (MOD : 1kHz±1.5kHz)						After input signal from SSG, press [B] key. That numeric will be stored in memory.	The following erroneous performance may occur if any irregular RSSI adjustment, such as pressing the [B] key assigned for determination when it is the ANT OPEN state, is performed. • The antenna bar () cannot appear correctly. • Scan does not stop.
• Wide	2) Adj item : [nL LRSSI] → [nC LRSSI] → [nH LRSSI] Adjust : [***] 3) Adj item : [w LRSSI] Adjust : [***] SSG output : 12dB SINAD level (MOD : 1kHz±3.0kHz)							
• Wide	4) Adj item : [wL LRSSI] → [wC LRSSI] → [wH LRSSI] Adjust : [***]							
5. Squelch (Tight) adjust • Narrow	1) Adj item : [n SQLT] Adjust : [***] SSG output : 12dB SINAD+5dB level (MOD : 1kHz±1.5kHz)						After input signal from SSG, press [B] key. That numeric will be stored in memory.	After adjusting SQL, check SQL open/close. SSG 12dB SINAD level +10dB : Open SSG 12dB SINAD level : Close [nC SQLT] MOD 1kHz±1.5kHz [wC SQLT] MOD 1kHz±3.0kHz
• Wide	2) Adj item : [nL SQLT] → [nC SQLT] → [nH SQLT] Adjust : [***] 3) Adj item : [w SQLT] Adjust : [***] SSG output : 12dB SINAD+5dB level (MOD : 1kHz±3.0kHz)							
• Wide	4) Adj item : [wL SQLT] → [wC SQLT] → [wH SQLT] Adjust : [***]							

ADJUSTMENT

Item	Condition	Measurement			Adjustment			Specifications/Remarks
		Test-equipment	Unit	Terminal	Unit	Parts	Method	
6. High RSSI adjust • Narrow	1) Adj item : [n HRSSI] Adjust : [***] SSG output : -70dBm (MOD : 1kHz±1.5kHz)	SSG AF VTVM Oscilloscope	Rear panel	ANT			After input signal from SSG, press [B] key. That numeric will be stored in memory.	The following erroneous performance may occur if any irregular RSSI adjustment, such as pressing the [B] key assigned for determination when it is the ANT OPEN state, is performed. • The antenna bar (Antenna icon) cannot appear correctly. • Scan does not stop.
	2) Adj item : [nL HRSSI] → [nC HRSSI] → [nH HRSSI] Adjust : [***]			EXT. SP				
	• Wide			3) Adj item : [w HRSSI] Adjust : [***] SSG output : -70dBm (MOD : 1kHz±3.0kHz)				
	4) Adj item : [wL HRSSI] → [wC HRSSI] → [wH HRSSI] Adjust : [***]							

TK-7180/7189/7180H Adjustment Points

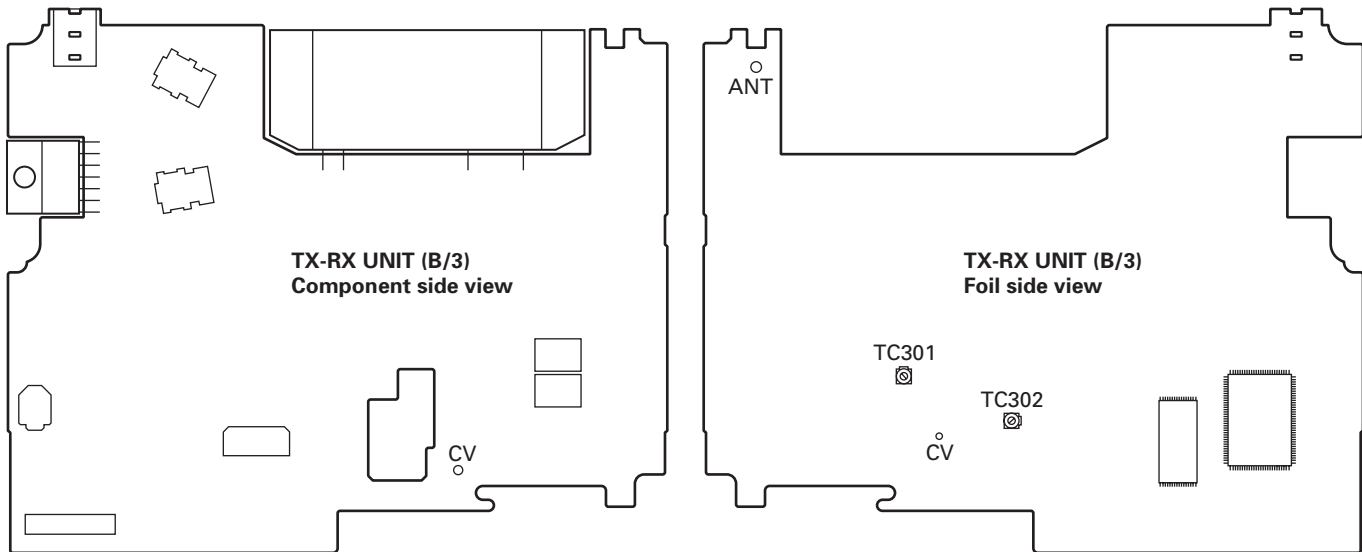

ADJUSTMENT

TK-8180/8189/8180H Common Section

Item	Condition	Measurement			Adjustment			Specifications/Remarks	
		Test-equipment	Unit	Terminal	Unit	Parts	Method		
1. Setting	1) Power supply voltage DC power supply terminal : 13.6V K,K2 , 13.2V E 2) SSG standard modulation [Wide] MOD : 1kHz, DEV : 3kHz [Narrow] MOD : 1kHz, DEV : 1.5kHz								
2. VCO lock voltage • RX	[Panel test mode] 1) CH-Sig : 3-1	Power meter	Rear panel	ANT	TX-RX (B/3)	TC301	8.1V	±0.1V	
	2) CH-Sig : 2-1	DVM	TX-RX (B/3)	CV			Check	1.5V±0.5V	
	• TX	[Panel tuning mode] LPWR* 3) CH-Sig : 3-1 PTT : ON				TX-RX (B/3)	TC302	8.1V	±0.1V
		4) CH-Sig : 2-1 PTT : ON						Check	1.5V±0.5V

* TX can be continued on unlock condition in panel tuning mode.

TK-8180/8189/8180H Transmitter Section

Item	Condition	Measurement			Adjustment			Specifications/Remarks
		Test-equipment	Unit	Terminal	Unit	Parts	Method	
1. Frequency adjust	1) Adj item : [FREQ] Adjust : [***] PTT : ON	f. counter	Rear panel	ANT	Front panel	[↗],[↘]	Center frequency ±100Hz	Note : After replacing the VCXO (X301) align frequency.
2. Frequency shift 1 adjust	1) Adj item : [SHFT1] Adjust : [***] 2) Adj item : [L SHFT1] → [C SHFT1] → [H SHFT1] Adjust : [***] PTT : ON						[L SHFT1] Low frequency+5.00kHz [C SHFT1] Center frequency+5.00kHz [H SHFT1] High frequency+5.00kHz	±100Hz
3. Frequency shift 2 adjust	1) Adj item : [SHFT2] Adjust : [***] 2) Adj item : [L SHFT2] → [C SHFT2] → [H SHFT2] Adjust : [***] PTT : ON						[L SHFT2] Low frequency+6.25kHz [C SHFT2] Center frequency+6.25kHz [H SHFT2] High frequency+6.25kHz	±100Hz

ADJUSTMENT

Item	Condition	Measurement			Adjustment			Specifications/Remarks
		Test-equipment	Unit	Terminal	Unit	Parts	Method	
4. Max high power adjust	1) Adj item : [MHPWR] Adjust : [***] 2) Adj item : [L MHPWR] → [L' MHPWR] → [C MHPWR] → [H' MHPWR] → [H MHPWR] Adjust : [***] PTT : ON	Power meter	Rear panel	ANT	Front panel	[↗],[↘]	[L MHPWR], [L' MHPWR], [C MHPWR] : 33W TK-8180 K,K2 : 28W TK-8180/8189 E : 48W TK-8180H K,K2 [H' MHPWR], : 33W TK-8180 K2 : 28W TK-8180 K,E /8189 E : 43W TK-8180H K : 48W TK-8180H K2 [H MHPWR] : 33W TK-8180 K2 : 28W TK-8180 K,E /8189 E : 38W TK-8180H K : 48W TK-8180H K2	±3W CAUTION! Do not attempt to adjust the transceiver's transmit output power beyond its specifications. If the transceiver is adjusted beyond the specifications, it may cause deterioration of the parts reliability and the output power may be lowered suddenly and unstable. The transceiver may be also extremely hot.
5. Max low power adjust	1) Adj item : [MLPWR] Adjust : [***] 2) Adj item : [L MLPWR] → [L' MLPWR] → [C MLPWR] → [H' MLPWR] → [H MLPWR] Adjust : [***] PTT : ON						15W TK-8180 K,K2 TK-8180/8189 E 25W TK-8180H K,K2	±1W TK-8180 K,K2 TK-8180/8189 E ±2W TK-8180H K,K2 CAUTION! Do not attempt to adjust the transceiver's transmit output power beyond its specifications. If the transceiver is adjusted beyond the specifications, it may cause deterioration of the parts reliability and the output power may be lowered suddenly and unstable. The transceiver may be also extremely hot.
6. High power adjust	1) Adj item : [HPWR] Adjust : [***] 2) Adj item : [L HPWR] → [L' HPWR] → [C HPWR] → [H' HPWR] → [H HPWR] Adjust : [***] PTT : ON	Power meter Ammeter					[L HPWR], [L' HPWR], [C HPWR] : 30W TK-8180 K,K2 : 23.5W TK-8180/8189 E : 45W TK-8180H K,K2 [H' HPWR] : 25W TK-8180 K : 30W TK-8180 K2 : 23.5W TK-8180/8189 E : 40W TK-8180H K : 45W TK-8180H K2 [H HPWR] : 25W TK-8180 K : 30W TK-8180 K2 : 23.5W TK-8180/8189 E : 35W TK-8180H K : 45W TK-8180H K2	±1W TK-8180/8180H K,K2 ±0.5W TK-8180/8189 E 9A or less TK-8180 K,K2 TK-8180/8189 E 13A or less TK-8180H K,K2

ADJUSTMENT

Item	Condition	Measurement			Adjustment			Specifications/Remarks
		Test-equipment	Unit	Terminal	Unit	Parts	Method	
7. High power check	[Panel test mode] 1) CH-Sig : 1-1 PTT : ON	Power meter Ammeter	Rear panel	ANT			Check	25~35W TK-8180 K,K2 21~26W TK-8180/8189 E 40~50W TK-8180H K,K2 9A or less TK-8180 K,K2 TK-8180/8189 E 13A or less TK-8180H K,K2
	2) CH-Sig : 2-1 PTT : ON							
	3) CH-Sig : 3-1 PTT : ON							
8. Low power adjust	1) Adj item : [LPWR] Adjust : [***] 2) Adj item : [L LPWR] → [L' LPWR] → [C LPWR] → [H' LPWR] → [H LPWR] Adjust : [***] PTT : ON				Front panel	[↗],[↘]	5.0W TK-8180 K,K2 TK-8180/8189 E 10W TK-8180H K,K2	±0.5W 5A or less TK-8180 K,K2 TK-8180/8189 E 8A or less TK-8180H K,K2
9. Low power check	[Panel test mode] 1) CH-Sig : 1-1 Set low power (Push [S]) PTT : ON						Check	3.5~6.5W TK-8180 K,K2 TK-8180/8189 E 7~13W TK-8180H K,K2 5A or less TK-8180 K,K2 TK-8180/8189 E 8A or less TK-8180H K,K2
	2) CH-Sig : 2-1 PTT : ON							
	3) CH-Sig : 3-1 PTT : ON							
10. DQT balance adjust	1) Adj item : [n BAL] Adjust : [***] Deviation meter filter LPF : 3kHz HPF : OFF • Narrow	Power meter Deviation meter Oscilloscope AG AF VTVM	Rear panel	ANT	Front panel	[↗],[↘]	Make the demodulation waves into square waves.	
	2) Adj item : [nL BAL] → [nC BAL] → [nH BAL] Adjust : [***] PTT : ON		Front panel	Modular MIC jack				
• Wide	3) Adj item : [w BAL] Adjust : [***] PTT : ON							
11. Max DEV adjust	1) Adj item : [n DEV] Adjust : [***] AG : 1kHz/50mV at MIC terminal Deviation meter filter LPF : 15kHz HPF : OFF • Narrow						2.10kHz (According to the larger +, -)	±0.10kHz
	2) Adj item : [nL DEV] → [nC DEV] → [nH DEV] Adjust : [***] PTT : ON							

ADJUSTMENT

Item	Condition	Measurement			Adjustment			Specifications/Remarks
		Test-equipment	Unit	Terminal	Unit	Parts	Method	
• Wide	3) Adj item : [w DEV] Adjust : [***] PTT : ON	Power meter	Rear panel	ANT	Front panel	[↗],[↘]	4.20kHz (According to the larger +, -)	±0.10kHz
12. MIC sensitivity check (Wide only)	[Panel test mode] 1) CH-Sig : 1-1 AG : 1kHz/5mV at MIC terminal PTT : ON	Deviation meter	Front panel	Modular MIC jack			Check	2.5~3.5kHz
13. QT deviation adjust	1) Adj item : [n QT] Adjust : [***] Deviation meter filter LPF : 3kHz HPF : OFF	Oscilloscope AG AF VTVM			Front panel	[↗],[↘]	0.35kHz	±0.05kHz
• Narrow	2) Adj item : [nL QT] → [nC QT] → [nH QT] Adjust : [***] PTT : ON							
• Wide	3) Adj item : [w QT] Adjust : [***] PTT : ON						0.75kHz	±0.10kHz
14. DQT deviation adjust	1) Adj item : [n DQT] Adjust : [***] Deviation meter filter LPF : 3kHz HPF : OFF						0.35kHz	±0.05kHz
• Narrow	2) Adj item : [nL DQT] → [nC DQT] → [nH DQT] Adjust : [***] PTT : ON							
• Wide	3) Adj item : [w DQT] Adjust : [***] PTT : ON						0.75kHz	±0.10kHz
15. DTMF deviation adjust	1) Adj item : [n DTMF] Adjust : [***] Deviation meter filter LPF : 15kHz HPF : OFF PTT : ON						1.5kHz	±0.1kHz
• Narrow								
• Wide	2) Adj item : [w DTMF] Adjust : [***] PTT : ON						3.0kHz	±0.1kHz
16. MSK deviation adjust	1) Adj item : [n MSK] Adjust : [**] Deviation meter filter LPF : 15kHz HPF : OFF PTT : ON						1.5kHz	±0.1kHz
• Narrow								
• Wide	2) Adj item : [w MSK] Adjust : [**] PTT : ON						3.0kHz	±0.1kHz

ADJUSTMENT

Item	Condition	Measurement			Adjustment			Specifications/Remarks
		Test-equipment	Unit	Terminal	Unit	Parts	Method	
17. TONE deviation adjust • Narrow	1) Adj item : [n TONE] Adjust : [***] Deviation meter filter LPF : 15kHz HPF : OFF PTT : ON	Power meter	Rear panel	ANT	Front panel	[↗],[↘]	1.5kHz	±0.1kHz
	• Wide	2) Adj item : [w TONE] Adjust : [***] PTT : ON	Deviation meter Oscilloscope AG AF VTVM	Front panel	Modular MIC jack		3.0kHz	

TK-8180/8189/8180H Receiver Section

Item	Condition	Measurement			Adjustment			Specifications/Remarks
		Test-equipment	Unit	Terminal	Unit	Parts	Method	
1. Sensitivity adjust	1) Adj item : [SENS1] Adjust : [***] 2) Adj item : [L SENS1] → [L' SENS1] → [C SENS1] → [H' SENS1] → [H SENS1] Adjust : [***]	SSG AF VTVM Oscilloscope	Rear panel	ANT EXT. SP	Front panel	[↗],[↘]	Enter the following adjustment values to the transceiver by pressing [↗] and [↘] keys. [L SENS1] : 70 TK-8180/8180H K : 95 TK-8180/8180H K2 TK-8180/8189 E [L' SENS1] : 90 TK-8180/8180H K : 123 TK-8180/8180H K2 TK-8180/8189 E [C SENS1] : 115 TK-8180/8180H K : 151 TK-8180/8180H K2 TK-8180/8189 E [H' SENS1] : 138 TK-8180/8180H K : 173 TK-8180/8180H K2 TK-8180/8189 E [H SENS1] : 164 TK-8180/8180H K : 195 TK-8180/8180H K2 TK-8180/8189 E After setting the adjustment value, press [B] key. The adjustment value will be stored in memory.	Note : After replacing the EEPROM (IC401) align sensitivity.

ADJUSTMENT

Item	Condition	Measurement			Adjustment			Specifications/Remarks
		Test-equipment	Unit	Terminal	Unit	Parts	Method	
2. Sensitivity check	[Panel test mode] 1) CH-Sig : 1-1 SSG output Wide 5k : -117dBm (0.32μV) (MOD : 1kHz±3kHz) Narrow : -116dBm (0.35μV) (MOD : 1kHz±1.5kHz)	SSG AF VTVM Oscilloscope	Rear panel	ANT EXT. SP			Check	12dB SINAD or more
3. Squelch (Preset) adjust • Narrow	1) Adj item : [n SQL] Adjust : [***] SSG output : 12dB SINAD level (MOD : 1kHz±1.5kHz)						After input signal from SSG, press [B] key. That numeric will be stored in memory.	After adjusting SQL, check SQL open/close. SSG 12dB SINAD level + 4dB : Open SSG 12dB SINAD level - 6dB : Close [nC SQL] MOD 1kHz±1.5kHz [wC SQL] MOD 1kHz±3.0kHz
	2) Adj item : [nL SQL] → [nC SQL] → [nH SQL] Adjust : [***]							
• Wide	3) Adj item : [w SQL] Adjust : [***] SSG output : 12dB SINAD level (MOD : 1kHz±3.0kHz)							
	4) Adj item : [wL SQL] → [wC SQL] → [wH SQL] Adjust : [***]							
4. Low RSSI adjust • Narrow	1) Adj item : [n LRSSI] Adjust : [***] SSG output : 12dB SINAD level (MOD : 1kHz±1.5kHz)						After input signal from SSG, press [B] key. That numeric will be stored in memory.	The following erroneous performance may occur if any irregular RSSI adjustment, such as pressing the [B] key assigned for determination when it is the ANT OPEN state, is performed. • The antenna bar (▼) cannot appear correctly. • Scan does not stop.
	2) Adj item : [nL LRSSI] → [nC LRSSI] → [nH LRSSI] Adjust : [***]							
• Wide	3) Adj item : [w LRSSI] Adjust : [***] SSG output : 12dB SINAD level (MOD : 1kHz±3.0kHz)							
	4) Adj item : [wL LRSSI] → [wC LRSSI] → [wH LRSSI] Adjust : [***]							
5. Squelch (Tight) adjust • Narrow	1) Adj item : [n SQLT] Adjust : [***] SSG output : 12dB SINAD+5dB level (MOD : 1kHz±1.5kHz)						After input signal from SSG, press [B] key. That numeric will be stored in memory.	After adjusting SQL, check SQL open/close. SSG 12dB SINAD level +10dB : Open SSG 12dB SINAD level : Close [nC SQLT] MOD 1kHz±1.5kHz [wC SQLT] MOD 1kHz±3.0kHz
	2) Adj item : [nL SQLT] → [nC SQLT] → [nH SQLT] Adjust : [***]							
• Wide	3) Adj item : [w SQLT] Adjust : [***] SSG output : 12dB SINAD+5dB level (MOD : 1kHz±3.0kHz)							
	4) Adj item : [wL SQLT] → [wC SQLT] → [wH SQLT] Adjust : [***]							

ADJUSTMENT

Item	Condition	Measurement			Adjustment			Specifications/Remarks
		Test-equipment	Unit	Terminal	Unit	Parts	Method	
6. High RSSI adjust • Narrow	1) Adj item : [n HRSSI] Adjust : [***] SSG output : -70dBm (MOD : 1kHz±1.5kHz)	SSG AF VTVM Oscilloscope	Rear panel	ANT			After input signal from SSG, press [B] key. That numeric will be stored in memory.	The following erroneous performance may occur if any irregular RSSI adjustment, such as pressing the [B] key assigned for determination when it is the ANT OPEN state, is performed. • The antenna bar () cannot appear correctly. • Scan does not stop.
	EXT. SP							
	2) Adj item : [nL HRSSI] → [nC HRSSI] → [nH HRSSI] Adjust : [***]							
	• Wide							
3) Adj item : [w HRSSI] Adjust : [***] SSG output : -70dBm (MOD : 1kHz±3.0kHz)								
4) Adj item : [wL HRSSI] → [wC HRSSI] → [wH HRSSI] Adjust : [***]								

TK-8180/8189/8180H Adjustment Points

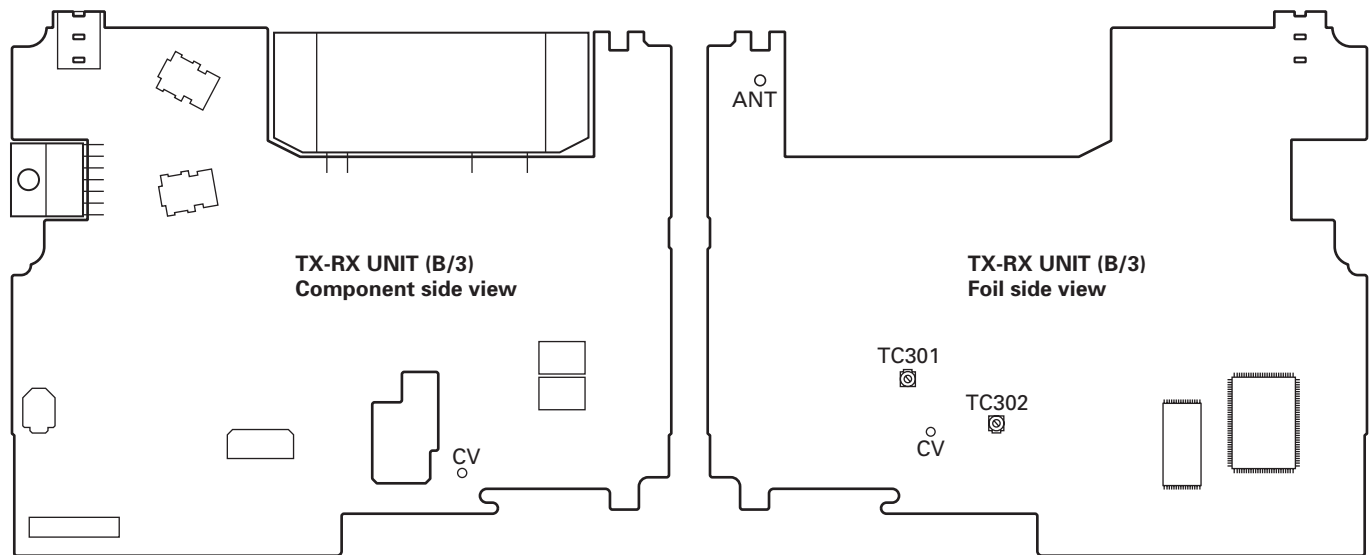

TK-7180/7189/7180H/8180/8189/8180H

Kenwood Corporation

2967-3, Ishikawa-machi, Hachioji-shi, Tokyo, 192-8525 Japan

Kenwood U.S.A. Corporation

P.O. BOX 22745, 2201 East Dominguez Street, Long Beach,
CA 90801-5745, U.S.A.

Kenwood Electronics Canada Inc.

6070 Kestrel Road, Mississauga, Ontario, Canada L5T 1S8

Kenwood Electronics Deutschland GmbH

Rembrücker Str. 15, 63150 Heusenstamm, Germany

Kenwood Electronics Belgium N.V.

Leuvensesteenweg 248 J, 1800 Vilvoorde, Belgium

Kenwood Electronics France S.A.

13, Boulevard Ney, 75018 Paris, France

Kenwood Electronics UK Limited

KENWOOD House, Dwight Road, Watford, Herts.,
WD18 9EB United Kingdom

Kenwood Electronics Europe B.V.

Amsterdamseweg 37, 1422 AC Uithoorn, The Netherlands

Kenwood Electronics Italia S.p.A.

Via G. Sirtori, 7/9 20129 Milano, Italy

Kenwood Ibérica, S.A.

Bolivia, 239-08020 Barcelona, Spain

Kenwood Electronics Australia Pty. Ltd.

(A.C.N. 001 499 074)

16 Giffnock Avenue, Centrecourt Estate, North Ryde, N.S.W. 2113 Australia

Kenwood Electronics (Hong Kong) Ltd.

Unit 3712-3724, Level 37, Tower one Metroplaza, 223 Hing Fong Road,
Kwai Fong, N.T., Hong Kong

Kenwood Electronics Singapore Pte Ltd

1 Ang Mo Kio Street 63, Singapore 569110