

Instruction Manual

for

MARCONI MARINE

OCEANIC

GP/SSB RECEIVER

© The Marconi International Marine Company Limited 1984

Published by
Technical Information Section
THE MARCONI INTERNATIONAL MARINE COMPANY LIMITED
Elettra House, Westway, Chelmsford (CM1 3BH), Essex, England.
A GEC-Marconi Electronics Company

HANDBOOK AMENDMENT RECORD

Amendments, in the form of new pages and/or instructions for hand amendments to existing pages, may be issued from time to time for this handbook. After incorporating an amendment, insert the amendment instruction pages at the rear of the book and record the incorporation of the amendment in the table below.

<i>Amendment</i>		
<i>No.</i>	<i>Incorporated by</i>	<i>Date</i>
1		
2		
3		
4		
5		
6		
7		
8		
9		
10		

TO ENSURE THAT YOU RECEIVE AMENDMENT INFORMATION, PLEASE ENTER YOUR SHIP AND COMPANY NAME AND ADDRESS ON THE PERFORATED CARD AT THE FRONT OF THIS BOOK AND RETURN IT TO THE ADDRESS ON THE REVERSE OF THE CARD.

POST DEVELOPMENT CHANGE RECORD

Post development changes to the equipment may necessitate amendments to the information contained in this handbook. Details of the changes will be contained in the PDS kit in the form of handbook amendments, for incorporation as detailed above. After inclusion of these amendments in the text, the appropriate change number or letter should be struck off the label below.

1	3	5	7	9	11	13	15	17	19	21	23
2	4	6	8	10	12	14	16	18	20	22	24
A	B	C	D	E	F	G	H	J	K	L	M

SAFETY SUMMARY

The following general safety precautions must be observed during all phases of operation, service, and repair of this equipment. Failure to comply with these precautions or with specific warnings elsewhere in this manual violates safety standards of design, manufacture, and intended use of equipment. Marconi Marine assumes no liability for the customer's failure to comply with these requirements.

GROUND THE EQUIPMENT

To minimize shock hazard, the equipment chassis and cabinet must be connected to an electrical ground. The equipment is equipped with a three-conductor ac power socket. The power cable must either be plugged into an approved three-contact electrical outlet or used with a three-contact to two-contact adapter with the grounding wire (green) firmly connected to an electrical ground (safety ground) at the power outlet.

DO NOT OPERATE IN AN EXPLOSIVE ATMOSPHERE

Do not operate the equipment in the presence of flammable gases or fumes. Operation of any electrical equipment in such an environment constitutes a definite safety hazard.

KEEP AWAY FROM LIVE CIRCUITS

Operating personnel must not remove equipment covers. Component replacement and internal adjustments must be made by qualified maintenance personnel. Do not replace components with power cable connected. Under certain conditions, dangerous voltages may exist even with the power cable removed. To avoid injuries, always disconnect power and discharge circuits before touching them.

SAFETY SUMMARY (continued)

DO NOT SERVICE OR ADJUST ALONE

Do not attempt internal service or adjustment unless another person, capable of rendering first aid and resuscitation, is present.

DO NOT SUBSTITUTE PARTS OR MODIFY EQUIPMENT

Because of the danger of introducing hazards, do not install substitute parts or perform any unauthorized modification to the equipment.

DANGEROUS PROCEDURE WARNINGS

Warnings, such as the example below, precede potentially dangerous procedures throughout this manual. Instructions contained in the warnings must be followed.

WARNING

Dangerous voltages, capable of causing death, are present in this equipment. Use extreme caution when handling, testing and adjusting.

FIRST AID IN CASE OF ELECTRIC SHOCK

The Royal Life Saving Society recommends the Expired Air method of artificial respiration for use in any case of electric shock. It is comparatively simple and produces the best and quickest results when correctly applied. It also has an important advantage over the accepted manual methods in that it can be carried out in awkward situations in confined spaces, such as might be encountered at sea.

However, where there is facial injury, or if the patient is trapped in a face downwards position, it might be necessary to use one of the manual methods of artificial respiration: of these types the Holger Nielson method is considered the most satisfactory.

Directions for applying both the Expired Air and the Holger Nielson methods are given below.

EXPIRED AIR METHOD

It is essential to commence artificial respiration without delay. Send for medical assistance if possible, but only if this can be done without delaying the commencement of respiration.

DO NOT TOUCH THE VICTIM WITH YOUR BARE HANDS until the circuit is broken.

SWITCH OFF. If this is not possible, **PROTECT YOURSELF** with dry insulating material and pull the victim clear of the conductor.

1. Lay the patient on his back and, if on a slope, have the stomach slightly lower than the chest.
2. Make a brief inspection of the mouth and throat to ensure that they are clear of obvious obstruction.
3. Give the patient's head the maximum backwards tilt so that the chin is prominent, the mouth closed and the neck stretched to give a clear airway — Fig. A.
4. Open your mouth wide, make an airtight seal over the nose of the patient with your mouth and blow. Use your cheek or the hand supporting the patient's chin to seal the patient's lips — Fig. B. If the nose is blocked, open the patient's mouth using the hand supporting the chin; open your mouth wide and make an airtight seal over the patient's mouth and blow — Fig. C. This second method may also be used as an alternative to the mouth-to-nose technique.
5. After exhaling, turn your head to watch for chest movement whilst inhaling deeply in readiness for blowing again — Fig. D.
6. If the chest does not rise, check that the patient's mouth and throat have not become blocked and that the head is tilted backwards as far as possible. Blow again.

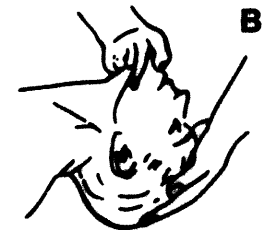

HOLGER NIELSON METHOD

It is essential to commence artificial respiration without delay. Send for medical assistance if possible, but only if this can be done without delaying the commencement of respiration.

DO NOT TOUCH THE VICTIM WITH YOUR BARE HANDS until the circuit is broken.

SWITCH OFF. If this is not possible, **PROTECT YOURSELF** with dry insulating material and pull the victim clear of the conductor.

1. Lay the patient face downwards with the forehead resting on the hands, placed one above the other.



2. Remove false teeth, tobacco or gum from patient's mouth; make sure the tongue is free by firm blows between the shoulders with the flat of the hand.

3. Kneel on one knee at the patient's head, with one foot by the patient's elbow.

4. Place the palms of your hands on the patient's shoulder blades – Fig. A.



5. Rock forward until your arms are vertical, the pressure should be light and without force (22 - 30lb. is sufficient). This should take approximately 2½ seconds — Fig. B.

6. Release the pressure by allowing your hands to slide down the patient's arms, to his elbows (approximately 1 second) then raise the patient's arms and shoulders by swinging backwards and pulling slightly at the same time (approximately 2½ seconds) — Fig. C. Lower the patient's arms — Fig. D — and return your hands to the patient's shoulder blades.



7. Repeat the movements taking 7 seconds for each complete respiration.

8. While artificial respiration is continued, have someone else:—

(a) loosen the patient's clothing,

(b) keep the patient warm.

9. If the patient's breathing stops (or does not commence) continue with the artificial respiration. It could be possible to achieve resuscitation after as long as four hours.



10. Do not give liquids until the patient is conscious.

TREATMENT FOR BURNS

1. No attempt should be made to remove clothing adhering to the burn.
2. Cover the burn with a dry dressing. If artificial respiration is in progress, a second party should attend to covering the burns.
3. No oil or grease of any form should be applied.
4. Warm, weak, sweet tea may be given when the patient is able to swallow.

These instructions are approved by The Royal Life Saving Society. A handbook and charts dealing with Artificial Respiration can be obtained from the Society at 14 Devonshire Street, London W.1

TABLE OF CONTENTS

Section	Page
1. GENERAL INFORMATION	Refer to Operators Manual
2. INSTALLATION	
3. OPERATION	
4.]-Not applicable to this manual	
5.]	
6 REPLACEABLE PARTS	6-1
6.1 Introduction	6-1
6.2 Abbreviations	6-1
6.3 Replaceable Parts List	6-1
6.4 Ordering Information	6-1
7 MANUAL CHANGES	7-1
8 SERVICE	8-1
8.1 Introduction	8-1
8.2 Theory of Operation	8-1
8.3 Troubleshooting	8-1
8.4 Self-Test Program	8-1
8.5 Preventive Maintenance	8-1
8.6 Front Panel Assembly Removal	8-2

TABLE OF CONTENTS (cont'd)

Section	Page
8.7 PC-Board Assembly Removal	8-2
8.8 Servicing PC-Boards	8-3
8.9 MOS Handling Precautions	8-3
8.10 Logic Devices	8-4
8.11 Basic Principles of Operation	8-4
8.12 Overall Operation	8-4
8.13 Synthesizer Assembly A1	8-7
8.14 Standard Assembly A2	8-8
8.15 Frontend Assembly A3	8-9
8.16 Preselector Assembly A4	8-10
8.17 IF/AF Assembly A7	8-11
8.18 Microcomputer Assembly A8	8-12
8.19 Power Supply Assembly A10	8-13
8.20 Front Panel Assembly A11A1	8-15
8.21 Mother Board A12A1	8-15

LIST OF ILLUSTRATIONS

Figure	Page
8.1 Overall Functional Block Diagram	8-5
8.2 Signal path block diagram	8-6
8.3 Synthesizer Assembly	8-7
8.4 Standard Assembly	8-8
8.5 Front-end Assembly	8-9
8.6 Preselector Assembly	8-10
8.7 IF/AF Assembly	8-12
8.8 Microcomputer Assembly	8-13
8.9 Power Supply Assembly	8-14

LIST OF TABLES

Table	Page
6.1 Reference Designations and Abbreviations	6-2
6.2 Replaceable Parts	6-4
6.3 List of Manufacturers Codes	6-88
7.1 Manual changes by serial Number	7-1
8.1 Typical Logic Levels	8-4
8.2 Fault Analysis procedure	8-16
8.3 Assembly Index	8-17

SECTION 6

REPLACEABLE PARTS

6.1 Introduction

This section contains information for ordering parts. Table 6.1 lists abbreviations used in the parts list, table 6.2 lists all replaceable parts in reference designator order, and table 6.3 contains names that correspond to the manufacturer's code numbers.

6.2 Abbreviations

Table 6.1 lists abbreviations used in the parts list, the schematics, and throughout the manual.

6.3 Replaceable Parts List

Table 6.2 lists replaceable parts and is organized as follows:

- a. Electrical assemblies in alpha-numerical order by reference designation.
- b. Chassis-mounted parts in alpha-numerical order by reference designation.
- c. Electrical assemblies and their components by alphanumerical order by reference designation.

The information given for each part consists of the following:

- a. Complete reference designation
- b. DRA stock number
- c. Description of part
- d. Typical manufacturer of part in identifying code
- e. Total quantity in first higher level

The total quantity in first higher level for each part is given only once - at the first appearance of the part number per lower level.

6.4 Ordering Information

To order a part listed in the replaceable parts table, quote the DRA part number, indicate the quantity required and address the order to **Marconi Marine**.

To order a part that is not listed in the replaceable parts list, include the receiver model number, receiver serial number, the description and function of the part, and the number of parts required. Address the order to **Marconi Marine**.

Table 6.1 Reference Designations and Abbreviations

REFERENCE DESIGNATIONS

A assembly	E miscellaneous electrical part	P electrical connector (movable portion); plug	U integrated circuit; microcircuit
AT attenuator; isolator; termination	F fuse	Q transistor; SCR; triode thyristor	V electron tube
B fan; motor	FL filter	R resistor	VR voltage regulator; breakdown diode
BT battery	H hardware	RT thermistor	W cable; transmission path; wire
C capacitor	HY circulator	S switch	X socket
CP coupler	J electrical connector (stationary portion); jack	T transformer	Y crystal unit (piezo-electric or quartz)
CR diode; diode thyristor; varactor	K relay	TB terminal board	Z tuned cavity; tuned circuit
DC directional coupler	L coil; inductor	TC thermocouple	
DL delay line	M meter	TP test point	
DS annunciator; signaling device (audible or visual); lamp; LED	MP miscellaneous mechanical part		

ABBREVIATIONS

A ampere	COMPL complete	FET field-effect transistor	LF low frequency
ac alternating current	CONN connector	F/F flip-flop	LG long
ACCESS accessory	CP cadmium plate	FH flat head	LH left hand
ADJ adjustment	CRT cathode-ray tube	FIL H fillister head	LIM limit
A/D analog-to-digital	CTL complementary transistor logic	FM frequency modulation	LIN linear taper (used in parts list)
AF audio frequency	CW continuous wave	FP front panel	lin linear
AFC automatic frequency control	cw clockwise	FREQ frequency	LK WASH lock washer
AGC automatic gain control	cm centimeter	FXD fixed	LO low; local oscillator
AL aluminum	D/A digital-to-analog	g gram	LOG logarithmic taper (used in parts list)
ALC automatic level control	dB decibel	GE germanium	log logarithm(ic)
AM amplitude modulation	dBm decibel referred to 1 mW	GHz gigahertz	LPF low pass filter
AMPL amplifier	dc direct current	GL glass	LV low voltage
APC automatic phase control	deg degree (temperature interval or difference)	GRD ground(ed)	m meter (distance)
ASSY assembly	° degree (plane angle)	H henry	mA milliampere
AUX auxiliary	°C degree Celsius (centigrade)	h hour	MAX maximum
avg average	°F degree Fahrenheit	HET heterodyne	MΩ megohm
AWG American wire gauge	°K degree Kelvin	HD head	MEG meg (10 ⁶) (used in parts list)
BAL balance	DEPC deposited carbon	HDW hardware	MET FLM metal film
BCD binary coded decimal	DET detector	HF high frequency	MET OX metallic oxide
BD board	diam diameter	HG mercury	MF medium frequency; microfarad (used in parts list)
BE CU beryllium copper	DIA diameter (used in parts list)	HI high	MFR manufacturer
BFO beat frequency oscillator	DIFF AMPL differential amplifier	HPF high pass filter	mg milligram
BH binder head	div division	HR hour (used in parts list)	MHz megahertz
BKDN breakdown	DPDT double-pole, double-throw	HV high voltage	mH millihenry
BP bandpass	DR drive	Hz Hertz	mho mho
BPF bandpass filter	DSB double sideband	IC integrated circuit	MIN minimum
BRS brass	DTL diode transistor logic	ID inside diameter	min minute (time)
BWO backward-wave oscillator	DVM digital voltmeter	IF intermediate frequency minute (plane angle)
CAL calibrate	ECL emitter coupled logic	IMPG impregnated	MINAT miniature
ccw counter-clockwise	EMF electromotive force	in inch	mm millimeter
CER ceramic	EDP electronic data processing	INCD incandescent	MOD modulator
CHAN channel	ELECT electrolytic	INCL include(s)	MOM momentary
cm centimeter	ENCAP encapsulated	INP input	MOS metal-oxide semiconductor
CMO cabinet mount only	EXT external	INS insulation	ms millisecond
COAX coaxial	F farad	INT internal	MTG mounting
COEF coefficient		kg kilogram	MTR meter (indicating device)
COM common		kHz kilohertz	mV millivolt
COMP composition		kΩ kilohm	mVac millivolt, ac
		kV kilovolt	mVdc millivolt, dc
		lb pound	mVpk millivolt, peak
		LC inductance-capacitance	
		LED light-emitting diode	

Table 6.1 Reference Designations and Abbreviations (continued)

mVp-p . . . millivolt, peak-to-peak	P peak (used in parts list)	REF reference	TERM terminal
mVrms millivolt, rms	PAM pulse-amplitude modulation	REG regulated	TFT thin-film transistor
mW milliwatt	PC printed circuit	REPL replaceable	TGL toggle
MUX multiplex	PCM pulse-code modulation; pulse-count modulation	RF radio frequency	THD thread
MY mylar	PDM pulse-duration modulation	RFI radio frequency interference	THRU through
μA microampere	pF picofarad	RH round head; right hand	TI titanium
μF microfarad	PH BRZ phosphor bronze	RLC resistance-inductance-capacitance	TOL tolerance
μH microhenry	PHL Phillips	RMO rack mount only	TRIM trimmer
μmho micromho	PIN positive-intrinsic-negative	rms root-mean-square	TSTR transistor
μs microsecond	PIV peak inverse voltage	RND round	TTL transistor-transistor logic
μV microvolt	pk peak	ROM read-only memory	TV television
μVac microvolt, ac	PL phase lock	R&P rack and panel	TVI television interference
μVdc microvolt, dc	PLO phase lock oscillator	RWV reverse working voltage	TWT traveling wave tube
μVpk microvolt, peak	PM phase modulation	S scattering parameter	U micro (10 ⁻⁶) (used in parts list)
μVp-p microvolt, peak-to-peak	PNP positive-negative-positive	s second (time)	UF microfarad (used in parts list)
μVrms microvolt, rms	P/O part of	s second (plane angle)	UHF ultrahigh frequency
μW microwatt	POLY polystyrene	S-B slow-blow (fuse) (used in parts list)	UNREG unregulated
nA nanoampere	POKC porcelain	SCR silicon controlled rectifier; screw	V volt
NC no connection	POS positive; position(s) (used in parts list)	SE selenium	VA voltampere
N/C normally closed	POSN position	SECT sections	Vac volts, ac
NE neon	POT potentiometer	SEMICON semiconductor	VAR variable
NEG negative	p-p peak-to-peak	SHF superhigh frequency	VCO voltage-controlled oscillator
nF nanofarad	PP peak-to-peak (used in parts list)	SI silicon	Vdc volts, dc
NI PL nickel plate	PPM pulse-position modulation	SIL silver	VDCW volts, dc, working (used in parts list)
N/O normally open	PREAMPL preamplifier	SL slide	V(F) volts, filtered
NOM nominal	PRF pulse-repetition frequency	SNR signal-to-noise ratio	VFO variable-frequency oscillator
NORM normal	PRR pulse repetition rate	SPDT single-pole, double-throw	VHF very-high frequency
NPN negative-positive-negative	ps picosecond	SPG spring	Vpk volts, peak
NPO negative-positive zero (zero temperature coefficient)	PT point	SR split ring	Vp-p volts, peak-to-peak
NRFR not recommended for field replacement	PTM pulse-time modulation	SPST single-pole, single-throw	Vrms volts, rms
NSR not separately replaceable	PWM pulse-width modulation	SSB single sideband	VSWR voltage standing wave ratio
ns nanosecond	PWV peak working voltage	SST stainless steel	VTO voltage-tuned oscillator
nW nanowatt	RC resistance-capacitance	STL steel	VTVM vacuum-tube voltmeter
OBD order by description	RECT rectifier	SQ square	V(X) volts, switched
OD outside diameter		SWR standing-wave ratio	W watt
OH oval head		SYNC synchronize	W/ with
OP AMPL operational amplifier		T timed (slow-blow fuse)	WIV working inverse voltage
OPT option		TA tantalum	WW wirewound
OSC oscillator		TC temperature compensating	W/O without
OX oxide		TD time delay	YIG yttrium-iron-garnet
oz ounce			Z ₀ characteristic impedance
Ω ohm			

MULTIPLIERS

Abbreviation	Prefix	Multiple
T	tera	10 ¹²
G	giga	10 ⁹
M	mega	10 ⁶
k	kilo	10 ³
da	deka	10
d	deci	10 ⁻¹
c	centi	10 ⁻²
m	milli	10 ⁻³
μ	micro	10 ⁻⁶
n	nano	10 ⁻⁹
p	pico	10 ⁻¹²
f	femto	10 ⁻¹⁵
a	atto	10 ⁻¹⁸

Table 6.2 Replaceable Parts (cont'd)

		TITLE OCEANIC	PARTS LIST		
REF DES	DRA PART NO	NOMENCLATURE OR DESCRIPTION		MFR CODE	QTY
FIND NO					
1	457841	INTERCONNECTION DIAGRAM			REF
2	457841	REAR PANEL VIEW			REF
3	457841	BLOCK DIAGRAM			REF
4	458651	OPERATING AND SERVICE MANUAL			1
5	458678	OPERATORS GUIDE			1
A1	448168	SYNTHESIZER	ASSY	EMK	1
A2	448184	STANDARD TCXO	ASSY	EMK	} SELECT
A2	460354	STANDARD OCXO	ASSY OPT. 005	EMK	
A3	448206	FRONT-END	ASSY	EMK	1
A4	458155	PRESELECTOR, EXCL. DUPLEX	ASSY	EMK	} SELECT
A4	448389	PRESELECTOR, INCL. DUPLEX	ASSY OPT. 003	EMK	
A4	459321	PRESELECTOR, SUBOCTAV	ASSY OPT. 001	EMK	
A7	448443	IF/AF	ASSY	EMK	1
A8	448478	MICROCOMPUTER	ASSY	EMK	1
A10	448532	POWER SUPPLY	ASSY	EMK	1
A11	457825	FRONT PANEL	ASSY	EMK	1
A12	457833	CHASSIS	ASSY	EMK	1
H1	327301	SCREW M5 X 20 CHM			4
H2	327263	SCREW M4 X 20 CHM			4
H3	450561	SCREW, SELFTAPPING			40
H4	336777	WASHER M4			4
H5	321966	WASHER M5			4
MP1	445991	REAR PANEL-DUMMY		EMK	2
W1	457868	CABLE ASSY, COAX		EMK	1
W2	457876	CABLE ASSY, COAX		EMK	1
W3	457884	CABLE ASSY, COAX		EMK	1
W4	457892	CABLE ASSY, COAX		EMK	1
W5	457906	CABLE ASSY, COAX		EMK	1

Table 6.2 Replaceable Parts (cont'd)

		TITLE	PARTS LIST	
		SYNTHESIZER		
REF DES	DRA PART NO	NOMENCLATURE OR DESCRIPTION	MFR CODE	QTY
FIND NO				
1	448141	PRINTED WIRING BOARD	EMK	1
2	448168	ELECTRICAL SCHEMATIC DIAGRAM		REF
3	448168	COMPONENT LOCATION DRAWING		REF
A1	455490	VCO ASSY	EMK	1
C1	450510	CAPACITOR, CER 100N/63S	SIE	54
C2	358959	CAPACITOR, CER 1N0/100K	PHI	14
C3	458457	CAPACITOR, PLST 330P/160J	SIE	1
C4	359645	CAPACITOR, PLST 160P/500F	PHI	1
C5	450839	CAPACITOR, PLST 560P/160J	SIE	1
C6	450812	CAPACITOR, PLST 1N0/160J	SIE	1
C7	202991	CAPACITOR, PLST 220N/100K	PHI	1
C8	357553	CAPACITOR, PLST 82P/63G	PHI	1
C9	209554	CAPACITOR, PLST 10N/250K	PHI	1
C10	209562	CAPACITOR, PLST 33N/100K	PHI	1
C11	357502	CAPACITOR, CER 33P/63G	PHI	2
C12	450359	CAPACITOR, ELCT, AL 1U0/25M	PHI	1
C13	450529	CAPACITOR, ELCT, AL 6U8/25S	PHI	7
C14	450510	CAPACITOR, CER 100N/63S	SIE	
C15	450510	CAPACITOR, CER 100N/63S	SIE	
C16	450510	CAPACITOR, CER 100N/63S	SIE	
C27	450510	CAPACITOR, CER 100N/63S	SIE	
C28	358959	CAPACITOR, CER 1N0/100K	PHI	
C29	450529	CAPACITOR, ELCT, AL 6U8/23S	PHI	
C30	358959	CAPACITOR, CER 1N0/100K	PHI	
C31	357480	CAPACITOR, CER 22P/63G	PHI	1
C32	357472	CAPACITOR, CER 18P/63G	PHI	1
C33	450510	CAPACITOR, CER 100N/63S	SIE	
C34	451053	CAPACITOR, ELCT, AL 68U/6,3S	PHI	5
C35	388959	CAPACITOR, CER 1N0/100K	PHI	
C36	450529	CAPACITOR, ELCT, AL 6U8/25S	PHI	
C37	358959	CAPACITOR, CER 1N0/100K	PHI	
C38	450510	CAPACITOR, CER 100N/63S	SIE	
C39	358959	CAPACITOR, CER 1N0/100K	PHI	
C40	450510	CAPACITOR, CER 100N/63S	SIE	
C41	358959	CAPACITOR, CER 1N0/100K	PHI	
C42	358959	CAPACITOR, CER 1N0/100K	PHI	
C43	358959	CAPACITOR, CER 1N0/100K	PHI	
C44	357537	CAPACITOR, CER 56P/63G	PHI	2

Table 6.2 Replaceable Parts (cont'd)

		TITLE SYNTHESIZER	PARTS LIST	
REF DES	DRA PART NO	NOMENCLATURE OR DESCRIPTION	MFR CODE	QTY
FIND NO				
C45	450529	CAPACITOR, ELCT, AL 6U8/25S	PHI	
C46	357502	CAPACITOR, CER 33P/63G	PHI	
C47	357448	CAPACITOR, CER 10P/63G	PHI	1
C48	450510	CAPACITOR, CER 100N/63S	SIE	
C49	450510	CAPACITOR, CER 100N/63S	SIE	
C50	450529	CAPACITOR, ELCT, AL 6U8/25S	PHI	
C51	450510	CAPACITOR, CER 100N/63S	SIE	
C52	450510	CAPACITOR, CER 100N/63S	SIE	
C53	450510	CAPACITOR, CER 100N/63S	SIE	
C54	450529	CAPACITOR, ELCT, AL 6U8/25S	PHI	
C55	450510	CAPACITOR, CER 100N/63S	SIE	
C56	450510	CAPACITOR, CER 100N/63S	SIE	
C57	450529	CAPACITOR, ELCT, AL 6U8/25S	PHI	
C58	450510	CAPACITOR, CER 100N/63S	SIE	
C59	450510	CAPACITOR, CER 100N/63S	SIE	
C60	450510	CAPACITOR, CER 100N/63S	SIE	
C61	450510	CAPACITOR, CER 100N/63S	SIE	
C62	450510	CAPACITOR, CER 100N/63S	SIE	
C63	451053	CAPACITOR, ELCT, AL 6U8/6,3S	PHI	
C64	450510	CAPACITOR, CER 100N/63S	SIE	
C65	450510	CAPACITOR, CER 100N/63S	SIE	
C66	450510	CAPACITOR, CER 100N/63S	SIE	
C67	450510	CAPACITOR, CER 100N/63S	SIE	
C68	450510	CAPACITOR, CER 100N/63S	SIE	
C69	450510	CAPACITOR, CER 100N/63S	SIE	
C70	450510	CAPACITOR, CER 100N/63S	SIE	
C71	450510	CAPACITOR, CER 100N/63S	SIE	
C72	450510	CAPACITOR, CER 100N/63S	SIE	
C73	450510	CAPACITOR, CER 100N/63S	SIE	
C74	450510	CAPACITOR, CER 100N/63S	SIE	
C75	450510	CAPACITOR, CER 100N/63S	SIE	
C76	450510	CAPACITOR, CER 100N/63S	SIE	
C77	450510	CAPACITOR, CER 100N/63S	SIE	
C78	450510	CAPACITOR, CER 100N/63S	SIE	
C79	450510	CAPACITOR, CER 100N/63S	SIE	
C80	450510	CAPACITOR, CER 100N/63S	SIE	
C81	450510	CAPACITOR, CER 100N/63S	SIE	
C82	450510	CAPACITOR, CER 100N/63S	SIE	
C83	450510	CAPACITOR, CER 100N/63S	SIE	
C84	450510	CAPACITOR, CER 100N/63S	SIE	
C85	450510	CAPACITOR, CER 100N/63S	SIE	
C86	450510	CAPACITOR, CER 100N/63S	SIE	

Table 6.2 Replaceable Parts (cont'd)

		TITLE	PARTS LIST	
		SYNTHESIZER		
REF DES	DRA PART NO	NOMENCLATURE OR DESCRIPTION	MFR CODE	QTY
FIND NO				
C87	450510	CAPACITOR, CER 100N/63S	SIE	
C88	450510	CAPACITOR, CER 100N/63S	SIE	
C89	451053	CAPACITOR, ELCT, AL 68U/6.3S	PHI	
C90	450510	CAPACITOR, CER 100N/63S	SIE	
C91	450510	CAPACITOR, CER 100N/63S	SIE	
C92	451053	CAPACITOR, ELCT, AL 68U/6.3S	PHI	
C93	451053	CAPACITOR, ELCT, AL 68U/6.3S	PHI	
C94	450510	CAPACITOR, CER 100N/63S	SIE	
C95	450510	CAPACITOR, CER 100N/63S	SIE	
C96	450510	CAPACITOR, CER 100N/63S	SIE	
C97	450510	CAPACITOR, CER 100N/63S	SIE	
C98	450510	CAPACITOR, CER 100N/63S	SIE	
C99	450510	CAPACITOR, CER 100N/63S	SIE	
C100	450510	CAPACITOR, CER 100N/63S	SIE	
C101	357405	CAPACITOR, CER 5P6/63C	PHI	1
C102	357537	CAPACITOR, CER 56P/63G	PHI	
C103	358959	CAPACITOR, CER 1N0/100K	PHI	
C104	358959	CAPACITOR, CER 1N0/100K	PHI	
C105	358959	CAPACITOR, CER 1N0/100K	PHI	
C106	358959	CAPACITOR, CER 1N0/100K	PHI	
C107	358959	CAPACITOR, CER 1N0/100K	PHI	
C108	459534	CAPACITOR, PLST 100N/63M	SIE	1
CR1	228087	DIODE, SI BAX 13	PHI	11
CR2	228087	DIODE, SI BAX 13	PHI	
CR3	228087	DIODE, SI BAX 13	PHI	
CR4	228087	DIODE, SI BAX 13	PHI	
CR5	228087	DIODE, SI BAX 13	PHI	
CR6	228087	DIODE, SI BAX 13	PHI	
CR7	228087	DIODE, SI BAX 13	PHI	
CR8		NOT USED		
CR9		NOT USED		
CR10		NOT USED		
CR11	228087	DIODE, SI BAX 13	PHI	
CR12		NOT USED		
CR18		NOT USED		
CR19	228087	DIODE, SI BAX 13	PHI	
CR20	228087	DIODE, SI BAX 13	PHI	
CR21	228087	DIODE, SI BAX 13	PHI	
H1	458694	SCREW M 2,5 x 5		13
H2	448680	CONTACT STRIP	ISP	0,1M
H3	454087	DISC, DISTANCE TO-18	PHI	5

Table 6.2 Replaceable Parts (cont'd)

		TITLE	PARTS LIST	
		SYNTHESIZER		
REF DES	DRA PART NO	NOMENCLATURE OR DESCRIPTION	MFR CODE	QTY
FIND NO				
J1	361399	CONNECTOR, RF 85SMB50-01	SUH	1
L3	389609	COIL, CHOKE 1M2 47UK	DAE	1
L4	357820	COIL, CHOKE 1M2 2U2K	DAE	5
L5	405493	COIL, CHOKE 1M4 0U47K	DAE	1
L6	393967	COIL, CHOKE 1M2 0U15K	DAE	1
L7	363944	COIL, CHOKE	PHI	4
L8	363944	COIL, CHOKE	PHI	
L9	363944	COIL, CHOKE	PHI	
L10	363944	COIL, CHOKE	PHI	
L11	355933	COIL, CHOKE 1M2 6U8K	DAE	4
L12	355933	COIL, CHOKE 1M2 6U8K	DAE	
L13	355933	COIL, CHOKE 1M2 6U8K	DAE	
L14	372889	COIL, CHOKE 1M4 5U6K	DAE	1
L15	355933	COIL, CHOKE 1M2 6U8K	DAE	
L16	394335	COIL, CHOKE 1M2 0U1K	DAE	1
L17	357820	COIL, CHOKE 1M2 2U2K	DAE	
L18	357820	COIL, CHOKE 1M2 2U2K	DAE	
L19	357820	COIL, CHOKE 1M2 2U2K	DAE	
L20	357820	COIL, CHOKE 1M2 2U2K	DAE	
MP1	460176	REAR PLATE	EMK	1
MP2	448095	PC RETAINER	EMK	1
MP3	260819	THUMB SCREW 5T18978	EMK	2
MP4	455571	STAY NUT	EMK	8
MP5	457612	SCREEN SHIELD 96 x 61	EMK	1
MP6	457604	SCREEN SHIELD 45 x 45	EMK	1
MP7	460273	SCREEN SHIELD	EMK	1
Q1	451320	TRANSISTOR, PNP 2N3906	MOT	10
Q2	451320	TRANSISTOR, PNP 2N3906	MOT	
Q3	455164	TRANSISTOR, NPN 2N3904	MOT	11
Q4	451320	TRANSISTOR, PNP 2N3906	MOT	
Q5	455172	TRANSISTOR, DUAL-J-FET 2N3958	SLX	1
Q6	455164	TRANSISTOR, NPN 2N3904	MOT	
Q7	455164	TRANSISTOR, NPN 2N3904	MOT	
Q8	451320	TRANSISTOR, PNP 2N3906	MOT	
Q9	455164	TRANSISTOR, NPN 2N3904	MOT	

Table 6.2 Replaceable Parts (cont'd)

		TITLE SYNTHESIZER	PARTS LIST	
REF DES	DRA PART NO	NOMENCLATURE OR DESCRIPTION	MFR CODE	QTY
FIND NO				
Q10	451320	TRANSISTOR, PNP 2N3906	MOT	
Q11	455164	TRANSISTOR, NPN 2N3904	MOT	
Q12	455164	TRANSISTOR, NPN 2N3904	MOT	
Q13	451320	TRANSISTOR, PNP 2N3906	MOT	
Q14	399914	TRANSISTOR, J-FET J309	SLX	1
Q15	455164	TRANSISTOR, NPN 2N3904	MOT	
Q16	455164	TRANSISTOR, NPN 2N3904	MOT	
Q17	450278	TRANSISTOR, D-MOS SD211	PHI	1
Q18	455164	TRANSISTOR, NPN 2N3904	MOT	
Q19	451320	TRANSISTOR, PNP 2N3906	MOT	
Q20	274070	TRANSISTOR, FET BFW11	PHI	1
Q21	273899	TRANSISTOR, NPN BC171B	ITT	3
Q22		NOT USED		
Q23	451274	TRANSISTOR, NPN MPS2369	MOT	3
Q24	273899	TRANSISTOR, NPN BC171B	ITT	
Q25	273899	TRANSISTOR, NPN BC171B	ITT	
Q26	359157	TRANSISTOR, PNP BC251B	ITT	1
Q27	357804	TRANSISTOR, NPN BFX89	PHI	2
Q28	357804	TRANSISTOR, NPN BFX89	PHI	
Q29	320668	TRANSISTOR, PNP BFX48	SGS	1
Q30	451274	TRANSISTOR, NPN MPS2369	PHI	
Q31	455164	TRANSISTOR, NPN 2N3904	PHI	
Q32	455164	TRANSISTOR, NPN 2N3904	PHI	
Q33	451274	TRANSISTOR, NPN MPS2369	PHI	
Q34	389730	TRANSISTOR, N-CHANNEL J-FET J300	SLX	2
Q35	451290	TRANSISTOR, P-CHANNEL J-FET 2N5460	NSC	2
Q36	451320	TRANSISTOR, PNP 2N3906	MOT	
Q37	451320	TRANSISTOR, PNP 2N3906	MOT	
Q38	451320	TRANSISTOR, PNP 2N3906	MOT	
Q39	389730	TRANSISTOR, N-CHANNEL J-FET J300	SLX	
Q40	451290	TRANSISTOR, P-CHANNEL J-FET 2N5460	NSC	
R1	240516	RESISTOR, CARB 4K7/0,25 J	PHI	9
R2	240354	RESISTOR, CARB 510R/0,25J	PHI	7
R3	240354	RESISTOR, CARB 510R/0,25J	PHI	
R4	240222	RESISTOR, CARB 100R/0,25J	PHI	7
R5	240265	RESISTOR, CARB 200R/0,25J	PHI	3
R6	240397	RESISTOR, CARB 820R/0,25J	PHI	3
R7	240125	RESISTOR, CARB 22R/0,25J	PHI	2
R8	240222	RESISTOR, CARB 100R/0,25J	PHI	

Table 6.2 Replaceable Parts (cont'd)

		TITLE	PARTS LIST	
		SYNTHESIZER		
REF DES	DRA PART NO	NOMENCLATURE OR DESCRIPTION	MFR CODE	QTY
FIND NO				
R9	240605	RESISTOR, CARB 15K/0,25j	PHI	2
R10	240222	RESISTOR, CARB 100R/0,25J	PHI	
R11	240443	RESISTOR, CARB 2K0/0,25J	PHI	7
R12	240222	RESISTOR, CARB 100R/0,25J	PHI	
R13	240605	RESISTOR, CARB 15K/0,25J	PHI	
R14	405590	RESISTOR, FILM 619R/0,125F	PHI	1
R15	240583	RESISTOR, CARB 12K/0,25J	PHI	2
R16	240451	RESISTOR, CARB 2K2/0,25J	PHI	3
R17	240184	RESISTOR, CARB 47R/0,25J	PHI	9
R18	240303	RESISTOR, CARB 300R/0,25J	PHI	1
R19	240389	RESISTOR, CARB 680R/0,25J	PHI	7
R20	240486	RESISTOR, CARB 3K3/0,25J	PHI	5
R21	240567	RESISTOR, CARB 10K/0,25J	PHI	6
R22	240125	RESISTOR, CARB 22R/0,25J	PHI	
R23	240486	RESISTOR, CARB 3K3/0,25J	PHI	
R24	240265	RESISTOR, CARB 200R/0,25J	PHI	
R25	240400	RESISTOR, CARB 1K0/0,25J	PHI	10
R26	240354	RESISTOR, CARB 510R/0,25J	PHI	
R27	240265	RESISTOR, CARB 200R/0,25J	PHI	
R28	240451	RESISTOR, CARB 2K2/0,25J	PHI	
R29	240389	RESISTOR, CARB 680R/0,25J	PHI	
R30	240567	RESISTOR, CARB 10K/0,25J	PHI	
R31	240567	RESISTOR, CARB 10K/0,25J	PHI	
R32	240567	RESISTOR, CARB 10K/0,25J	PHI	
R33	240524	RESISTOR, CARB 5K6/0,25J	PHI	2
R34	240621	RESISTOR, CARB 22K/0,25J	PHI	4
R35	240427	RESISTOR, CARB 1K5/0,25J	PHI	1
R36	240516	RESISTOR, CARB 4K7/0,25J	PHI	
R37	240621	RESISTOR, CARB 22K/0,25J	PHI	
R38	240354	RESISTOR, CARB 510R/0,25J	PHI	
R39	240354	RESISTOR, CARB 510R/0,25J	PHI	
R40	240621	RESISTOR, CARB 22K/0,25J	PHI	
R41	240516	RESISTOR, CARB 4K7/0,25J	PHI	
R42	450979	RESISTOR, CARB 360R/0,25J	PHI	4
R43	240222	RESISTOR, CARB 100R/0,25J	PHI	
R50	240419	RESISTOR, CARB 1K2/0,25J	PHI	2
R51	372064	RESISTOR, CARB 9K1/0,25J	PHI	1
R52	240443	RESISTOR, CARB 2K0/0,25J	PHI	
R53	240400	RESISTOR, CARB 1K0/0,25J	PHI	
R54	240451	RESISTOR, CARB 2K2/0,25J	PHI	
R55	240222	RESISTOR, CARB 100R/0,25J	PHI	

Table 6.2 Replaceable Parts (cont'd)

		TITLE	PARTS LIST	
		SYNTHESIZER		
REF DES	DRA PART NO	NOMENCLATURE OR DESCRIPTION	MFR CODE	QTY
FIND NO				
R56	240400	RESISTOR, CARB 1K0/0,25J	PHI	
R57	328545	RESISTOR, CARB 220R/0,25J	PHI	2
R58	240230	RESISTOR, CARB 120R/0,25J	PHI	4
R59	240206	RESISTOR, CARB 56R/0,25J	PHI	
R60	240230	RESISTOR, CARB 120R/0,25J	PHI	
R61	240362	RESISTOR, CARB 560R/0,25J	PHI	1
R62	240230	RESISTOR, CARB 120R/0,25J	PHI	
R63	240192	RESISTOR, CARB 51R/0,25J	PHI	2
R64	240230	RESISTOR, CARB 120R/0,25J	PHI	
R65	240567	RESISTOR, CARB 10K/0,25J	PHI	
R66	240338	RESISTOR, CARB 390R/0,25J	PHI	3
R67	240400	RESISTOR, CARB 1k0/0,25J	PHI	
R68		NOT USED		
R69	246400	RESISTOR, CARB 1K0/0,25	PHI	
R70	240192	RESISTOR, CARB 51R/0,25J	PHI	
R71	324205	RESISTOR, CARB 5K1/0,25J	PHI	4
R72	324221	RESISTOR, CARB 2K4/0,25J	PHI	1
R73	240222	RESISTOR, CARB 100R/0,25J	PHI	
R74	328545	RESISTOR, CARB 220R/0,25J	PHI	
R75	240354	RESISTOR, CARB 510R/0,25J	PHI	
R76	362913	RESISTOR, CARB 15R/0,25J	PHI	1
R77	240400	RESISTOR, CARB 1K0/0,25J	PHI	
R78	450979	RESISTOR, CARB 360R/0,25J	PHI	
R79	240338	RESISTOR, CARB 390R/0,25J	PHI	
R80	450979	RESISTOR, CARB 360R/0,25J	PHI	
R81	240389	RESISTOR, CARB 680R/0,25J	PHI	
R82	240389	RESISTOR, CARB 680R/0,25J	PHI	
R83	240354	RESISTOR, CARB 510R/0,25J	PHI	
R84	240389	RESISTOR, CARB 680R/0,25J	PHI	
R85	450979	RESISTOR, CARB 360R/0,25J	PHI	
R86	240338	RESISTOR, CARB 390R/0,25J	PHI	
R87	240389	RESISTOR, CARB 680R/0,25J	PHI	
R88	240257	RESISTOR, CARB 180R/0,25J	PHI	3
R89	240257	RESISTOR, CARB 180R/0,25J	PHI	
R90	240257	RESISTOR, CARB 180R/0,25J	PHI	
R91	363251	RESISTOR, CARB 39R/0,25J	PHI	1
R92	240281	RESISTOR, CARB 270R/0,25J	PHI	2
R93	240397	RESISTOR, CARB 820R/0,25J	PHI	
R94	240281	RESISTOR, CARB 270R/0,25J	PHI	
R95	240516	RESISTOR, CARB 4K7/0,25J	PHI	
R96	240397	RESISTOR, CARB 820R/0,25J	PHI	

Table 6.2 Replaceable Parts (cont'd)

		TITLE SYNTHESIZER	PARTS LIST	
REF DES	DRA PART NO	NOMENCLATURE OR DESCRIPTION	MFR CODE	QTY
FIND NO				
R97	367826	RESISTOR, FILM 2K49/0,125F	VIT	2
R98	367826	RESISTOR, FILM 2K49/0,125F	VIT	
R99	376477	RESISTOR, FILM 1K27/0,125F	VIT	1
R100	240311	RESISTOR, CARB 330R/0,25J	PHI	1
R101	240494	RESISTOR, CARB 3K9/0,25J	PHI	3
R102	240400	RESISTOR, CARB 1K0/0,25J	PHI	
R103	240443	RESISTOR, CARB 2K0/0,25J	PHI	
R104	240494	RESISTOR, CARB 3K9/0,25J	PHI	
R105	240443	RESISTOR, CARB 2K0/0,25J	PHI	
R106	240400	RESISTOR, CARB 1K0/0,25J	PHI	
R107	240494	RESISTOR, CARB 3K9/0,25J	PHI	
R108	240400	RESISTOR, CARB 1K0/0,25J	PHI	
R109	240443	RESISTOR, CARB 2K0/0,25J	PHI	
R110	324205	RESISTOR, CARB 5K1/0,25J	PHI	
R111	324191	RESISTOR, CARB 7K5/0,25J	PHI	2
R112	240370	RESISTOR, CARB 620R/0,25J	PHI	1
R113	240486	RESISTOR, CARB 3K3/0,25J	PHI	
R114	240435	RESISTOR, CARB 1K8/0,25J	PHI	1
R115	240583	RESISTOR, CARB 12K/0,25J	PHI	
R116	240524	RESISTOR, CARB 5K6/0,25J	PHI	
R117	240621	RESISTOR, CARB 22K/0,25J	PHI	
R118	240516	RESISTOR, CARB 4K7/0,25J	PHI	
R119	240516	RESISTOR, CARB 4K7/0,25J	PHI	
R120	240486	RESISTOR, CARB 3K3/0,25J	PHI	
R121	240184	RESISTOR, CARB 47R/0,25J	PHI	
R122	240346	RESISTOR, CARB 470R/0,25J	PHI	1
R123	240516	RESISTOR, CARB 4K7/0,25J	PHI	
R124	240567	RESISTOR, CARB 10K/0,25J	PHI	
R125	240419	RESISTOR, CARB 1K2/0,25J	PHI	
R126	359335	RESISTOR, FILM 78K7/0,125F	VIT	1
R127	240400	RESISTOR, CARB 1K0/0,25J	PHI	
R128	455210	RESISTOR, FILM 604K/0,125F	VIT	1
R129	371033	RESISTOR, FILM 100R/0,125F	VIT	3
R130	376574	RESISTOR, FILM 2K0/0,125F	VIT	1
R131	371033	RESISTOR, FILM 100R/0,125F	VIT	
R132	372102	RESISTOR, FILM 332R/0,125F	VIT	2
R133	458309	RESISTOR, FILM 332K/0,125F	VIT	1
R134	359408	RESISTOR, VAR 50K/0,5K	BOU	1
R135	372102	RESISTOR, FILM 332R/0,125F	VIT	
R136	371033	RESISTOR, FILM 100R/0,125F	VIT	
R137	363235	RESISTOR, VAR 5K/0,5K	BOU	1

Table 6.2 Replaceable Parts (cont'd)

		TITLE SYNTHESIZER	PARTS LIST	
REF DES	DRA PART NO	NOMENCLATURE OR DESCRIPTION	MFR CODE	QTY
FIND NO				
R138	455199	RESISTOR, FILM 100K/0,125D	VIT	1
R139	455180	RESISTOR, FILM 100R/0,125D	VIT	1
R140	349631	RESISTOR, FILM 33K2/0,125F	VIT	1
R141	324205	RESISTOR, CARB 5K1/0,25J	PHI	
R142	324205	RESISTOR, CARB 5K1/0,25J	PHI	
R143	240389	RESISTOR, CARB 680R/0,25J	PHI	
R144	240680	RESISTOR, CARB 47K/0,25J	PHI	2
R145	240680	RESISTOR, CARB 47K/0,25J	PHI	
R146	376361	RESISTOR, FILM 825R/0,125F	PHI	1
R147	324191	RESISTOR, CARB 7K5/0,25J	PHI	
R148	240486	RESISTOR, CARB 3K3/0,25J	PHI	
R150	240184	RESISTOR, CARB 47R/0,25J	PHI	
R151	240184	RESISTOR, CARB 47R/0,25J	PHI	
R152	240184	RESISTOR, CARB 47R/0,25J	PHI	
R153	240184	RESISTOR, CARB 47R/0,25J	PHI	
R154	240184	RESISTOR, CARB 47R/0,25J	PHI	
R155	240184	RESISTOR, CARB 47R/0,25J	PHI	
R156	376531	RESISTOR, FILM 511R/0,125F	VIT	3
R157	376531	RESISTOR, FILM 511R/0,125F	VIT	
R158	376531	RESISTOR, FILM 511R/0,125F	VIT	
R159	240516	RESISTOR, CARB 4K7/0,25J	PHI	
R160	240516	RESISTOR, CARB 4K7/0,25J	PHI	
R161	240184	RESISTOR, CARB 47R/0,25J	PHI	
TP1-12	231304	TEST POINT		12
U1	451150	INTEGRATED CKT SN74LS699	TII	3
U2	451150	INTEGRATED CKT SN74LS699	TII	
U3	451150	INTEGRATED CKT SN74LS699	TII	
U4	404608	INTEGRATED CKT SN74S74	TII	2
U5	365874	INTEGRATED CKT SN74LS74	TII	6
U6	365874	INTEGRATED CKT SN74LS74	TII	
U7	365874	INTEGRATED CKT SN74LS74	TII	
U8	454761	INTEGRATED CKT SN74LS174	TII	2
U9	454761	INTEGRATED CKT SN74LS174	TII	
U10	451207	INTEGRATED CKT SN74LS283	TII	3
U11	451207	INTEGRATED CKT SN74LS283	TII	
U12	451207	INTEGRATED CKT SN74LS283	TII	
U13	386073	INTEGRATED CKT SN74LS193	TII	3

Table 6.2 Replaceable Parts (cont'd)

		TITLE	PARTS LIST	
		SYNTHESIZER		
REF DES	DRA PART NO	NOMENCLATURE OR DESCRIPTION	MFR CODE	QTY
FIND NO				
U14	386073	INTEGRATED CKT SN74LS193	TII	
U15	386073	INTEGRATED CKT SN74LS193	TII	
U16	451185	INTEGRATED CKT SN74LS02	TII	2
U17	454788	INTEGRATED CKT SN74LS192	TII	1
U18	365874	INTEGRATED CKT SN74LS74	TII	
U19	365874	INTEGRATED CKT SN74LS74	TII	
U20	365874	INTEGRATED CKT SN74LS74	TII	
U21	404608	INTEGRATED CKT SN74S74	TII	
U22	450367	INTEGRATED CKT MC10131	MOT	2
U23	450367	INTEGRATED CKT MC10131	MOT	
U24	450383	INTEGRATED CKT MC10106	MOT	1
U25	451266	INTEGRATED CKT LM301AN	NSC	1
U26	450375	INTEGRATED CKT MC10116	MOT	1
U27	454753	INTEGRATED CKT LM393	NSC	1
U28	454745	INTEGRATED CKT LM310N	NSC	1
U29	455113	INTEGRATED CKT LM308N	NSC	1
U30	451282	INTEGRATED CKT LF356N	NSC	1
U31	357898	INTEGRATED CKT SN74S112	TII	1
U32	451304	INTEGRATED CKT CA3046	RCA	1
U33	433683	INTEGRATED CKT SN74LS138	TII	1
U34	362131	INTEGRATED CKT SN7406	TII	1
U35	451185	INTEGRATED CKT SN74LS02	TII	
U36	451630	INTEGRATED CKT SN74LS379	TII	1
U37	451169	INTEGRATED CKT SN74LS365	TII	1
U38	451029	INTEGRATED CKT SN74LS377	TII	3
U39	451029	INTEGRATED CKT SN74LS377	TII	
U40	451029	INTEGRATED CKT SN74LS377	TII	
VR1	228788	DIODE, SD, ZENER ZPD 10	ITT	1
VR2	454389	DIODE, SD, ZENER ZPD 16	ITT	2
VR3	454389	DIODE, SD, ZENER ZPD 16	ITT	
VR4	228850	DIODE, SD, ZENER ZPD 6.2	ITT	5
VR5	228850	DIODE, SD, ZENER ZPD 6.2	ITT	
VR6	228850	DIODE, SD, ZENER ZPD 6.2	ITT	
VR7	228850	DIODE, SD, ZENER ZPD 6.2	ITT	
VR8	228850	DIODE, SD, ZENER ZPD 6.2	ITT	
W1	458775	CABLE	EMK	1
W2	458783	CABLE	EMK	1
W3	458791	CABLE	EMK	1

Table 6.2 Replaceable Parts (cont'd)

		TITLE	PARTS LIST	
		SYNTHESIZER VCO		
REF DES	DRA PART NO	NOMENCLATURE OR DESCRIPTION	MFR CODE	QTY
FIND NO				
1	455482	PRINTED WIRING BOARD	EMK	1
2	448168	ELECTRICAL SCHEMATIC DIAGRAM		REF
3	448168	COMPONENT LOCATION DRAWING		REF
C17	358959	CAPACITOR, CER 1N0/100K	PHI	7
C18	358959	CAPACITOR, CER 1N0/100K	PHI	
C19	455148	CAPACITOR, CER 18P/63J	KCK	1
C20	455121	CAPACITOR, CER 10P/63J	KCK	1
C21	358959	CAPACITOR, CER 1N0/100K	PHI	
C22	450855	CAPACITOR, CER 47P/63J	KCK	1
C23	358959	CAPACITOR, CER 1N0/100K	PHI	
C24	358959	CAPACITOR, CER 1N0/100K	PHI	
C25	358959	CAPACITOR, CER 1N0/100K	PHI	
C26	358959	CAPACITOR, CER 1N0/100K	PHI	
CR13	358614	DIODE, SWITCH BA182	PHI	4
CR14	358614	DIODE, SWITCH BA182	PHI	
CR15	358614	DIODE, SWITCH BA182	PHI	
CR16	358614	DIODE, SWITCH BA182	PHI	
CR17	405531	DIODE, CAP BB204B	SIE	1
CR22	228087	DIODE, SI BAX 13	PHI	1
H1	458287	SCREW M 2,5 X 8 CHM		4
H2	231304	TIE POINT		7
H3	454087	DISC, DISTANCE TO-18	PHI	1
L1	455237	COIL, OSC, 100NH	EMK	1
L2	357820	COIL, CHOKE 1M2 2U2K	DAE	1
MP1	457620	SCREEN SHIELD	EMK	1
MP2	396834	STAY NUT 4T22745	EMK	4
Q22	455229	TRANSISTOR, MOS-FET MFE131	MOT	1
R44	455210	RESISTOR, FILM 604K/0,125F	VIT	2

Table 6.2 Replaceable Parts (cont'd)

		TITLE SYNTHESIZER VCO	PARTS LIST	
REF DES	DRA PART NO	NOMENCLATURE OR DESCRIPTION	MFR CODE	QTY
FIND NO				
R45	455210	RESISTOR, FILM 604K/0,125F	VIT	
R46	359335	RESISTOR, FILM 78K7/0,125F	VIT	1
R47	349585	RESISTOR, FILM 56K2/0,125F	VIT	1
R48	371033	RESISTOR, FILM 100R/0,125F	VIT	2
R49	371033	RESISTOR, FILM 100R/0,125F	VIT	
R149	349674	RESISTOR, FILM 15K0/0,125F	VIT	1

Table 6.2 Replaceable Parts (cont'd)

		TITLE STANDARD	PARTS LIST	
REF DES	DRA PART NO	NOMENCLATURE OR DESCRIPTION	MFR CODE	QTY
FIND NO				
1	448176	PRINTED WIRING BOARD	EMK	1
2	448184	ELECTRICAL SCHEMATIC DIAGRAM		REF
3	448184	COMPONENT LOCATION DRAWING		REF
C1	450529	CAPACITOR, ELCT, AL 6U8/25S	PHI	11
C2	450898	CAPACITOR, PLST 0U33/63J	PHI	1
C3	448850	CAPACITOR, PLST 2N2/630F	SIE	1
C4	450529	CAPACITOR, ELCT, AL 6U8/25S	PHI	
C5	357561	CAPACITOR, CER 100P/100G	PHI	2
C6	450529	CAPACITOR, ELCT, AL 6U8/25S	PHI	
C7	358959	CAPACITOR, CER 1N/100K	PHI	9
C8	450847	CAPACITOR, CER 33P/100J	KCK	1
C9	450855	CAPACITOR, CER 47P/100J	KCK	1
C10	390380	CAPACITOR, CER 470P/100K	PHI	1
C11	357561	CAPACITOR, CER 100P/100G	PHI	
C12	357634	CAPACITOR, CER 2N2/100K	PHI	3
C13	358959	CAPACITOR, CER 1N/100K	PHI	
C14	358959	CAPACITOR, CER 1N/100K	PHI	
C15	358939	CAPACITOR, CER 1N/100K	PHI	
C16		NOT USED		
C17	450510	CAPACITOR, CER 100N/63S	SIE	27
C18	451053	CAPACITOR, ELCT, AL 68U/6,3S	PHI	1
C19	357510	CAPACITOR, CER 39P/100G	PHI	1
C20	358959	CAPACITOR, CER 1N/100K	PHI	
C21	450510	CAPACITOR, CER 100N/6S	SIE	
C22	358959	CAPACITOR, CER 1N/100K	PHI	
C23	357634	CAPACITOR, CER 2N2/100K	PHI	
C24	357634	CAPACITOR, CER 2N2/100K	PHI	
C25	209570	CAPACITOR, PLST 47N/100K	PHI	2
C26	450510	CAPACITOR, CER 100N/63S	SIE	
C27	450529	CAPACITOR, ELCT, AL 6U8/25S	PHI	
C28	358959	CAPACITOR, CER 1N/100K	PHI	
C29	448885	CAPACITOR, PLST 4N7/160F	SIE	1
C30	450529	CAPACITOR, ELCT, AL 6U8/25S	PHI	
C31	448877	CAPACITOR, PLST 3N3/160F	SIE	1
C32	209570	CAPACITOR, PLST 47N/100K	PHI	
C33	209554	CAPACITOR, PLST 10N/400K	PHI	1
C34	450804	CAPACITOR, PLST 3N/160F	SIE	1
C35	357480	CAPACITOR, CER 22P/100G	PHI	1
C36	357545	CAPACITOR, CER 68P/100G	PHI	1

Table 6.2 Replaceable Parts (cont'd)

		TITLE STANDARD	PARTS LIST	
REF DES	DRA PART NO	NOMENCLATURE OR DESCRIPTION	MFR CODE	QTY
FIND NO				
C37	450510	CAPACITOR, CER 100N/63S	SIE	
C38	358959	CAPACITOR, CER 1N/100K	PHI	
C39	450812	CAPACITOR, PLST 1N/160J	SIE	3
C40	450820	CAPACITOR, PLST 220P/630J	SIE	1
C41	357650	CAPACITOR, CER 22N/40A	CRL	1
C42	450812	CAPACITOR, PLST 1N/160J	SIE	
C43	450812	CAPACITOR, PLST 1N/160J	SIE	
C44	358959	CAPACITOR, CER 1N/100K	PHI	
C45	450529	CAPACITOR, ELCT, AL 6U8/25S	PHI	
C46	450510	CAPACITOR, CER 100N/63S	SIE	
C47	450529	CAPACITOR, ELCT, AL 6U8/25S	PHI	
C48	450839	CAPACITOR, PLST 560P/160J	SIE	1
C49	450510	CAPACITOR, CER 100N/63S	SIE	
C50	450529	CAPACITOR, ELCT, AL 6U8/25S	PHI	
C51	357596	CAPACITOR, CER 150P/100G	PHI	1
C52	450529	CAPACITOR, ELCT, AL 6U8/25S	PHI	
C53	450529	CAPACITOR, ELCT, AL 6U8/25S	PHI	
C54	450529	CAPACITOR, ELCT, AL 6U8/25S	PHI	
C55	450510	CAPACITOR, CER 100N/63S	SIE	
C56	450510	CAPACITOR, CER 100N/63S	SIE	
C57	450510	CAPACITOR, CER 100N/63S	SIE	
C58	450510	CAPACITOR, CER 100N/63S	SIE	
C59	450510	CAPACITOR, CER 100N/63S	SIE	
C60	450510	CAPACITOR, CER 100N/63S	SIE	
C61	450510	CAPACITOR, CER 100N/63S	SIE	
C62	450510	CAPACITOR, CER 100N/63S	SIE	
C63	450510	CAPACITOR, CER 100N/63S	SIE	
C64	450510	CAPACITOR, CER 100N/63S	SIE	
C65	450510	CAPACITOR, CER 100N/63S	SIE	
C66	450510	CAPACITOR, CER 100N/63S	SIE	
C67	450510	CAPACITOR, CER 100N/63S	SIE	
C68	450510	CAPACITOR, CER 100N/63S	SIE	
C69	450510	CAPACITOR, CER 100N/63S	SIE	
C70	450510	CAPACITOR, CER 100N/63S	SIE	
C71	450510	CAPACITOR, CER 100N/63S	SIE	
C72	450510	CAPACITOR, CER 100N/63S	SIE	
C73	450510	CAPACITOR, CER 100N/63S	SIE	
C74	357499	CAPACITOR, CER 27P/100G	PHI	1
C75	450510	CAPACITOR, CER 100N/63S	SIE	
C76	450510	CAPACITOR, CER 100N/63S	SIE	

Table 6.2 Replaceable Parts (cont'd)

		TITLE STANDARD	PARTS LIST	
REF DES	DRA PART NO	NOMENCLATURE OR DESCRIPTION	MFR CODE	QTY
FIND NO				
CR1	451061	DIODE, CAP BB405B	PHI	1
CR2		NOT USED		
CR3		NOT USED		
CR4	344966	DIODE, SI 1N4148	ITT	6
CR5	344966	DIODE, SI 1N4148	ITT	
CR6	344966	DIODE, SI 1N4148	ITT	
CR7	344966	DIODE, SI 1N4148	ITT	
CR8	405531	DIODE, CAP BB204B	SIE	2
CR9	405531	DIODE, CAP BB204B	SIE	
CR10	344966	DIODE, SI 1N4148	ITT	
CR11	344966	DIODE, SI 1N4148	ITT	
H1	458694	SCREW M 2,5 x 5 CHM		5
H2	450065	SCREEN SHIELD	VGT	2
J1	361399	CONNECTOR, RF 85SMB50-01	SUH	2
J2	361399	CONNECTOR, RF 85SMB50-01	SUH	.
L1	454524	COIL, RF	EMK	1
L2	450405	COIL, CHOKE 0U68/K	DAE	2
L3	450405	COIL, CHOKE 0U68/K	DAE	
L4	394343	COIL, CHOKE 1UH/K	DAE	3
L5	363294	COIL, CHOKE 47UH/J	DAE	2
L6	375330	COIL, CHOKE 0U22/K	DAE	2
L7	375330	COIL, CHOKE 0U22/K	DAE	
L8	394343	COIL, CHOKE 1UH/K	DAE	
L9	394343	COIL, CHOKE 1UH/K	DAE	
L10	363944	COIL, CHOKE 750R/M	PHI	6
L11	363944	COIL, CHOKE 750R/M	PHI	
L12	363944	COIL, CHOKE 750R/M	PHI	
L13	363944	COIL, CHOKE 750R/M	PHI	
L14	363944	COIL, CHOKE 750R/M	PHI	
L15		NOT USED		
L16	450413	COIL, CHOKE 1MH/K	DAE	1
L17	363294	COIL, CHOKE 47UH/J	DAE	
L18	454532	COIL, RF	EMK	1
L19	450774	COIL, CHOKE 33U/K	DAE	1
L20	450782	COIL, CHOKE 82U/K	DAE	1
L21	363944	COIL, CHOKE 750R/M	PHI	
L22	450766	COIL, CHOKE 27U/J	DAE	1

Table 6.2 Replaceable Parts (cont'd)

		TITLE STANDARD	PARTS LIST	
REF DES	DRA PART NO	NOMENCLATURE OR DESCRIPTION	MFR CODE	QTY
FIND NO				
MP1	460184	REAR PLATE	EMK	1
MP2	448095	PC RETAINER	EMK	1
MP3	260819	THUMB SCREW 5T18978	EMK	2
MP4	459356	CONTACT SPRING 1	EMK	1
MP5	459364	CONTACT SPRING 2	EMK	1
Q1	399914	TRANSISTOR, N-CHANNEL J-FET J309	SLX	1
Q2	359157	TRANSISTOR, PNP BC251B	ITT	2
Q3	451274	TRANSISTOR, NPN MPS2369	MOT	5
Q4	451320	TRANSISTOR, PNP 2N3906	MOT	2
Q5	451320	TRANSISTOR, PNP 2N3906	MOT	
Q6	273899	TRANSISTOR, NPN BC171B	ITT	5
Q7	451274	TRANSISTOR, NPN MPS2369	MOT	
Q8	451290	TRANSISTOR, P-CHANNEL J-FET 2N5460	NSC	1
Q9	389730	TRANSISTOR, N-CHANNEL J-FET J300	SLX	1
Q10	273899	TRANSISTOR, NPN BC171B	ITT	
Q11	451312	TRANSISTOR, NPN BF199	PHI	1
Q12	273899	TRANSISTOR, NPN BC171B	ITT	
Q13	359157	TRANSISTOR, PNP BC251B	ITT	
Q14	273899	TRANSISTOR, NPN BC171B	ITT	
Q15	451274	TRANSISTOR, NPN MPS2369	MOT	
Q16	451274	TRANSISTOR, NPN MPS2369	MOT	
Q17	273899	TRANSISTOR, NPN BC171B	ITT	
Q18	451274	TRANSISTOR, NPN MPS2369	MOT	
R1	240400	RESISTOR, CARB 1K0/0,25J	PHI	16
R2	240400	RESISTOR, CARB 1K0/0,25J	PHI	
R3	240451	RESISTOR, CARB 2K2/0,25J	PHI	1
R4	240125	RESISTOR, CARB 22R/0,25J	PHI	3
R5	376515	RESISTOR, FILM 3K65/0,25F	VIT	1
R6	349569	RESISTOR, FILM 6K81/0,25F	VIT	3
R7	349526	RESISTOR, FILM 4K75/0,25F	VIT	3
R8	349623	RESISTOR, FILM 10K/0,25F	VIT	2
R9	349526	RESISTOR, FILM 4K75/0,25F	VIT	
R10	349526	RESISTOR, FILM 4K75/0,25F	VIT	
R11	349496	RESISTOR, FILM 100K/0,25F	VIT	2
R12	349518	RESISTOR, FILM 39K2/0,25F	VIT	1
R13	349623	RESISTOR, FILM 10K/0,25F	VIT	
R14	349496	RESISTOR, FILM 100K/0,25F	VIT	
R15	240281	RESISTOR, CARB 270R/0,25J	PHI	1
R16	444871	RESISTOR, FILM 27K4/0,25F	VIT	2

Table 6.2 Replaceable Parts (cont'd)

		TITLE	PARTS LIST	
		STANDARD		
REF DES	DRA PART NO	NOMENCLATURE OR DESCRIPTION	MFR CODE	QTY
FIND NO				
R17	240109	RESISTOR, CARB 10R/0,25J	PHI	1
R18	444871	RESISTOR, FILM 27K4/0,25F	VIT	
R19	376345	RESISTOR, FILM 274R/0,25F	VIT	1
R20	328545	RESISTOR, CARB 220R/0,25J	PHI	7
R21	240338	RESISTOR, CARB 390R/0,25J	PHI	4
R22	240338	RESISTOR, CARB 390R/0,25J	PHI	
R23	328545	RESISTOR, CARB 220R/0,25J	PHI	
R24	240516	RESISTOR, CARB 4K7/0,25J	PHI	2
R25	240494	RESISTOR, CARB 3K9/0,25J	PHI	2
R26	240273	RESISTOR, CARB 240R/0,25J	PHI	1
R27	363251	RESISTOR, CARB 39R/0,25J	PHI	1
R28	359572	RESISTOR, CARB 110R/0,25J	PHI	2
R29	240362	RESISTOR, CARB 560R/0,25J	PHI	5
R30	240400	RESISTOR, CARB 1K0/0,25J	PHI	
R31	240125	RESISTOR, CARB 22R/0,25J	PHI	
R32	328545	RESISTOR, CARB 220R/0,25J	PHI	
R33	328545	RESISTOR, CARB 220R/0,25J	PHI	
R34	240362	RESISTOR, CARB 560R/0,25J	PHI	
R35	240338	RESISTOR, CARB 390R/0,25J	PHI	
R36	240338	RESISTOR, CARB 390R/0,25J	PHI	
R37	328545	RESISTOR, CARB 220R/0,25J	PHI	
R38	240257	RESISTOR, CARB 180R/0,25J	PHI	1
R39	240362	RESISTOR, CARB 560R/0,25J	PHI	
R40	240567	RESISTOR, CARB 10K/0,25J	PHI	13
R41	240540	RESISTOR, CARB 6K8/0,25J	PHI	3
R42	240567	RESISTOR, CARB 10K/0,25J	PHI	
R43	240605	RESISTOR, CARB 15K/0,25J	PHI	2
R44	240567	RESISTOR, CARB 10K/0,25J	PHI	
R45	372137	RESISTOR, CARB 20K/0,25J	PHI	1
R46	240400	RESISTOR, CARB 1K0/0,25J	PHI	
R47	240478	RESISTOR, CARB 2K7/0,25J	PHI	4
R48	240400	RESISTOR, CARB 1K0/0,25J	PHI	
R49		RESISTOR, VAR 10-TURN 25K (PART OF 451142)		1
R50	240400	RESISTOR, CARB 1K0/0,25J	PHI	
R51	240540	RESISTOR, CARB 6K8/0,25J	PHI	
R52	451096	RESISTOR, FILM 4K75/0,25D	VIT	8
R53	451096	RESISTOR, FILM 4K75/0,25D	VIT	
R54	240567	RESISTOR, CARB 10K/0,25J	PHI	
R55	451096	RESISTOR, FILM 4K75/0,25D	VIT	
R56	451096	RESISTOR, FILM 4K75/0,25D	VIT	
R57	451096	RESISTOR, FILM 4K75/0,25D	VIT	

Table 6.2 Replaceable Parts (cont'd)

		TITLE	PARTS LIST	
		STANDARD		
REF DES	DRA PART NO	NOMENCLATURE OR DESCRIPTION	MFR CODE	QTY
FIND NO				
R58	451096	RESISTOR, FILM 4K75/0,25D	VIT	
R59	349593	RESISTOR, FILM 2K74/0,25F	VIT	1
R60	451096	RESISTOR, FILM 4K75/0,25D	VIT	
R61	451118	RESISTOR, FILM 560R/0,25D	VIT	1
R62	451126	RESISTOR, FILM 10K/0,25D	VIT	1
R63	240583	RESISTOR, CARB 12K/0,25J	PHI	1
R64	240567	RESISTOR, CARB 10K/0,25J	PHI	
R65	349607	RESISTOR, FILM 18K2/0,25F	VIT	1
R66	349569	RESISTOR, FILM 6K81/0,25F	VIT	
R67	349569	RESISTOR, FILM 6K81/0,25F	VIT	
R68	365831	RESISTOR, CARB 680K/0,25J	PHI	1
R69	451134	RESISTOR, FILM 12K4/0,25D	VIT	1
R70	451096	RESISTOR, FILM 4K75/0,25D	VIT	
R71	451088	RESISTOR, FILM 20K/0,25D	VIT	1
R72	436879	RESISTOR, VAR 20K/0,75K	PHI	1
R73	240400	RESISTOR, CARB 1K0/0,25J	PHI	
R74	240605	RESISTOR, CARB 15K/0,25J	PHI	
R75	240478	RESISTOR, CARB 2K7/0,25J	PHI	
R76	240362	RESISTOR, CARB 560R/0,25J	PHI	
R77	240478	RESISTOR, CARB 2K7/0,25J	PHI	
R78	240567	RESISTOR, CARB 10K/0,25J	PHI	
R79	240400	RESISTOR, CARB 1K0/0,25J	PHI	
R80	240400	RESISTOR, CARB 1K0/0,25J	PHI	
R81	240346	RESISTOR, CARB 470R/0,25J	PHI	2
R82	240567	RESISTOR, CARB 10K/0,25J	PHI	
R83	240362	RESISTOR, CARB 560R/0,25J	PHI	
R84	240400	RESISTOR, CARB 1K0/0,25J	PHI	
R85	240214	RESISTOR, CARB 82R/0,25J	PHI	1
R86	240494	RESISTOR, CARB 3K9/0,25J	PHI	
R87	328545	RESISTOR, CARB 220R/0,25J	PHI	
R88	240125	RESISTOR, CARB 22R/0,25J	PHI	
R89	328545	RESISTOR, CARB 220R/0,25J	PHI	
R90	240400	RESISTOR, CARB 1K0/0,25J	PHI	
R91	240400	RESISTOR, CARB 1K0/0,25J	PHI	
R92	240400	RESISTOR, CARB 1K0/0,25J	PHI	
R93	240478	RESISTOR, CARB 2K7/0,25J	PHI	
R94	240346	RESISTOR, CARB 470R/0,25J	PHI	
R95	240567	RESISTOR, CARB 10K/0,25J	PHI	
R96	240540	RESISTOR, CARB 6K8/0,25J	PHI	
R97	240567	RESISTOR, CARB 10K/0,25J	PHI	
R98	240567	RESISTOR, CARB 10K/0,25J	PHI	

Table 6.2 Replaceable Parts (cont'd)

		TITLE	PARTS LIST	
		STANDARD		
REF DES	DRA PART NO	NOMENCLATURE OR DESCRIPTION	MFR CODE	QTY
FIND NO				
R99	240400	RESISTOR, CARB 1K0/0,25J	PHI	
R100	240400	RESISTOR, CARB 1K0/0,25J	PHI	
R101	240567	RESISTOR, CARB 10K/0,25J	PHI	
R102	240567	RESISTOR, CARB 10K/0,25J	PHI	
R103		NOT USED		
R104	240567	RESISTOR, CARB 10K/0,25J	PHI	
R105	240400	RESISTOR, CARB 1K0/0,25J	PHI	
R106	240516	RESISTOR, CARB 4K7/0,25J	PHI	
TP1-17	231304	TEST POINT		17
U1	434825	INTEGRATED CKT SN74LS163	TII	4
U2	434825	INTEGRATED CKT SN74LS163	TII	
U3	365874	INTEGRATED CKT SN74LS74	TII	4
U4		NOT USED		
U5	451231	INTEGRATED CKT LM723CN	NSC	1
U6	451282	INTEGRATED CKT LF356N	NSC	3
U7	442933	INTEGRATED CKT SN74LS393	TII	1
U8		NOT USED		
U9	404705	INTEGRATED CKT SN74LS00	TII	1
U10	450375	INTEGRATED CKT MC10116	MOT	1
U11	357898	INTEGRATED CKT SN74S112	TII	1
U12	451177	INTEGRATED CKT SN74LS290	TII	1
U13	434825	INTEGRATED CKT SN74LS163	TII	
U14	434825	INTEGRATED CKT SN74LS163	TII	
U15	365874	INTEGRATED CKT SN74LS74	TII	
U16	433535	INTEGRATED CKT SN74LS04	TII	1
U17	451258	INTEGRATED CKT LM2901	NSC	1
U18	365874	INTEGRATED CKT SN74LS74	TII	
U19	451282	INTEGRATED CKT LF356	NSC	
U20	451282	INTEGRATED CKT LF356	NSC	
U21	451266	INTEGRATED CKT LM301AN	NSC	1
U22	451215	INTEGRATED CKT AMDAC-08EQ	AMD	1
U23	451304	INTEGRATED CKT CA3046	RCA	1
U24	433683	INTEGRATED CKT SN74LS138	TII	1
U25	451185	INTEGRATED CKT SN74LS02	TII	1
U26	362131	INTEGRATED CKT SN7406	TII	1
U27	451169	INTEGRATED CKT SN74LS365	TII	1
U28	451029	INTEGRATED CKT SN74LS377	TII	2

Table 6.2 Replaceable Parts (cont'd)

		TITLE	PARTS LIST	
		STANDARD		
REF DES	DRA PART NO	NOMENCLATURE OR DESCRIPTION	MFR CODE	QTY
FIND NO				
U29	451029	INTEGRATED CKT SN74LS377	TII	
U30	451193	INTEGRATED CKT SN74LS175	TII	3
U31	451193	INTEGRATED CKT SN74LS175	TII	
U32	451207	INTEGRATED CKT SN74LS283	TII	3
U33	451207	INTEGRATED CKT SN74LS283	TII	
U34	451193	INTEGRATED CKT SN74LS175	TII	
U35	451207	INTEGRATED CKT SN74LS283	TII	
U36	365874	INTEGRATED CKT SN74LS74	TII	
U37	451150	INTEGRATED CKT SN74LS699	TII	2
U38	451150	INTEGRATED CKT SN74LS699	TII	
VR1	228818	DIODE, SD, ZENER 2V7/0,4J	ITT	1
VR2	451223	DIODE, SD, ZENER 2V4/0,4J	PHI	1
VR3	228842	DIODE, SD, ZENER 5V6/0,4J	ITT	2
VR4	228842	DIODE, SD, ZENER 5V6/0,4J	ITT	
Y1	357928	CRYSTAL 73,6 MHZ	EMK	1
Y2	451142	CRYSTAL OSC, TCXO 10,24 MHZ	KRI	1

Table 6.2 Replaceable Parts (cont'd)

		TITLE	PARTS LIST	
		FRONT-END		
REF DES	DRA PART NO	NOMENCLATURE OR DESCRIPTION	MFR CODE	QTY
FIND NO				
1	448192	PRINTED WIRING BOARD	EMK	1
2	448206	ELECTRICAL SCHEMATIC DIAGRAM		REF
3	448206	COMPONENT LOCATION DRAWING		REF
A1	448222	INPUT AMPLIFIER ASSY	EMK	1
A2	448249	1. MIXER ASSY	EMK	1
A3	448265	LO AMPLIFIER ASSY	EMK	1
A4	448281	1. IF AMPLIFIER ASSY	EMK	1
A5	448311	75 MHZ AGC AMPLIFIER ASSY	EMK	1
A6	448346	2. MIXER ASSY	EMK	1
A7	448362	2. IF AMPLIFIER ASSY	EMK	1
C1	450952	CAPACITOR, CER FEED THROUGH 910121,54	FRP	1
C67	450510	CAPACITOR, CER 100N/63S	SIE	25
C68	450510	CAPACITOR, CER 100N/63S	SIE	
C69	450510	CAPACITOR, CER 100N/63S	SIE	
C70	450510	CAPACITOR, CER 100N/63S	SIE	
C71	450510	CAPACITOR, CER 100N/63S	SIE	
C72	450510	CAPACITOR, CER 100N/63S	SIE	
C73	450510	CAPACITOR, CER 100N/63S	SIE	
C74	450510	CAPACITOR, CER 100N/63S	SIE	
C75	450510	CAPACITOR, CER 100N/63S	SIE	
C76	450510	CAPACITOR, CER 100N/63S	SIE	
C77	450510	CAPACITOR, CER 100N/63S	SIE	
C78	450510	CAPACITOR, CER 100N/63S	SIE	
C79	448834	CAPACITOR, PLST 1N5/630F	SIE	1
C80	450510	CAPACITOR, CER 100N/63S	SIE	
C81	450510	CAPACITOR, CER 100N/63S	SIE	
C82	450529	CAPACITOR, ELCT, AL 6U8/25M	PHI	3
C83	450510	CAPACITOR, CER 100N/63S	SIE	
C84	450510	CAPACITOR, CER 100N/63S	SIE	
C85	450510	CAPACITOR, CER 100N/63S	SIE	
C86	450529	CAPACITOR, ELCT, AL 6U8/25M	PHI	
C87	450510	CAPACITOR, CER 100N/63S	SIE	
C88	450510	CAPACITOR, CER 100N/63S	SIE	
C89	450510	CAPACITOR, CER 100N/63S	SIE	
C90	450529	CAPACITOR, ELCT, AL 6U8/25M	PHI	
C91	450510	CAPACITOR, CER 100N/63S	SIE	
C92	450510	CAPACITOR, CER 100N/63S	SIE	

Table 6.2 Replaceable Parts (cont'd)

		TITLE FRONT-END	PARTS LIST		
REF DES	DRA PART NO	NOMENCLATURE OR DESCRIPTION	MFR CODE	QTY	
FIND NO					
C93	450510	CAPACITOR, CER 100N/63S	SIE	7	
C94	450510	CAPACITOR, CER 100N/63S	SIE		
C95	450510	CAPACITOR, CER 100N/63S	SIE		
C96	358959	CAPACITOR, CER 1N0/100K	PHI		
C97	358959	CAPACITOR, CER 1N0/100K	PHI		
C98	358959	CAPACITOR, CER 1N0/100K	PHI		
C99	358959	CAPACITOR, CER 1N0/100K	PHI		
C100	358959	CAPACITOR, CER 1N0/100K	PHI	1	
C101	358959	CAPACITOR, CER 1N0/100K	PHI		
C102	358959	CAPACITOR, CER 1N0/100K	PHI		
C104	458708	CAPACITOR, ELCT, AL 2U2/25M	PHI		
CR4	450944	DIODE, SI 1S921	FAI		8
CR5	450944	DIODE, SI 1S921	FAI		
CR6	450944	DIODE, SI 1S921	FAI		
CR7	450944	DIODE, SI 1S921	FAI		
CR8	450944	DIODE, SI 1S921	FAI		
CR9	450944	DIODE, SI 1S921	FAI		
CR10	450944	DIODE, SI 1S921	FAI		
CR11	450944	DIODE, SI 1S921	FAI		
E1	375314	FERRITE BEAD	SIE	9	
E2	375314	FERRITE BEAD	SIE		
E3	375314	FERRITE BEAD	SIE		
E4	375314	FERRITE BEAD	SIE		
E5	375314	FERRITE BEAD	SIE		
E6	375314	FERRITE BEAD	SIE		
E7	375314	FERRITE BEAD	SIE		
E8	375314	FERRITE BEAD	SIE		
E9	375314	FERRITE BEAD	SIE		
FL1	363367	CRYSTAL FILTER 75MHZ BW12 KHZ 4T21399	EMK	1	
FL2	454060	CRYSTAL FILTER 5,4 KHZ DSB FILTER	EMK	1	
FL3	454052	CRYSTAL FILTER 2,35 KHZ LSB FILTER	EMK	1	
FL4	361666	CRYSTAL FILTER 1 KHZ DSB 4T21393	EMK	1	
FL5	361763	CRYSTAL FILTER 0,2 KHZ DSB 4T21394	EMK	1	
FL6	450960	VHF FILTER 9/0168,50	FRP	8	
FL7	450960	VHF FILTER 9/0168,50	FRP		

Table 6.2 Replaceable Parts (cont'd)

		TITLE	PARTS LIST	
		FRONT-END		
REF DES	DRA PART NO	NOMENCLATURE OR DESCRIPTION	MFR CODE	QTY
FIND NO				
FL8	450960	VHF FILTER 9/0168,50	FRP	
FL9	450960	VHF FILTER 9/0168,50	FRP	
FL10	450960	VHF FILTER 9/0168,50	FRP	
FL11	450960	VHF FILTER 9/0168,50	FRP	
FL12	450960	VHF FILTER 9/0168,50	FRP	
FL13	450960	VHF FILTER 9/0168,50	FRP	
H1	276758	SCREW M 2 x 6 CHM		28
H2	458694	SCREW M 2,5 x 5 CHM		5
H3	438227	PLASTIC TUBING Ø 0,7 x Ø 1,2	VTL	0,2 M
H4	325619	SCREW, SELFTAPPING		4
H5	450065	SCREEN SHIELD	VGT	1
J1	361399	CONNECTOR, RF 85SMB50-01	SUH	1
L31	450413	COIL, CHOKE IM2 1M/K	DAE	4
L32	450413	COIL, CHOKE IM2 1M/K	DAE	
L33	450413	COIL, CHOKE IM2 1M/K	DAE	
L34	450413	COIL, CHOKE IM2 1M/K	DAE	
L35		NOT USED		
L36	363944	COIL, CHOKE	PHI	5
L37	363944	COIL, CHOKE	PHI	
L38	363944	COIL, CHOKE	PHI	
L39	363944	COIL, CHOKE	PHI	
L40	363944	COIL, CHOKE	PHI	
MP1	460192	REAR PLATE	EMK	1
MP2	448095	PC RETAINER	EMK	1
MP3	260819	THUMB SCREW 5T18978	EMK	2
MP4	460001	SCREEN SHIELD ASSY	EMK	1
R60	240400	RESISTOR, CARB 1K0/0,25J	PHI	6
R61	240400	RESISTOR, CARB 1K0/0,25J	PHI	
R62	240400	RESISTOR, CARB 1K0/0,25J	PHI	
R63	240400	RESISTOR, CARB 1K0/0,25J	PHI	
R64	240605	RESISTOR, CARB 15K/0,25J	PHI	4
R65	240605	RESISTOR, CARB 15K/0,25J	PHI	

Table 6.2 Replaceable Parts (cont'd)

		TITLE	PARTS LIST	
		FRONT-END		
REF DES	DRA PART NO	NOMENCLATURE OR DESCRIPTION	MFR CODE	QTY
FIND NO				
R66	240605	RESISTOR, CARB 15K/0,25J	PHI	
R67	240605	RESISTOR, CARB 15K/0,25J	PHI	
R68	240400	RESISTOR, CARB 1K0/0,25J	PHI	
R69	240400	RESISTOR, CARB 1K0/0,25J	PHI	
T7	451908	TRAFO	EMK	1
TP1-8	231304	TESTPOINT		9
TP-GND	231304	TESTPOINT		
U4	362131	INTEGRATED CKT SN7406N	TII	1
U5	433683	INTEGRATED CKT SN74LS138	TII	1
U6	451630	INTEGRATED CKT SN74LS379	TII	1
W1	458805	CABLE ASSY	EMK	1
W2	458813	CABLE ASSY	EMK	1
W3	458821	CABLE ASSY	EMK	1
W4-11	394297	COBBER WIRE 0,5 MM		0,4M

Table 6.2 Replaceable Parts (cont'd)

		TITLE FRONT-END INPUT AMPLIFIER	PARTS LIST	
REF DES	DRA PART NO	NOMENCLATURE OR DESCRIPTION	MFR CODE	QTY
FIND NO				
1	448214	PRINTED WIRING BOARD	EMK	1
2	448206	ELECTRICAL SCHEMATIC DIAGRAM		REF
3	448206	COMPONENT LOCATION DRAWING		REF
C2	357553	CAPACITOR, CER 82P/63G	PHI	1
C3	450529	CAPACITOR, ELCT, AL 6U8/25M	PHI	5
C4	450510	CAPACITOR, CER 100N/63S	SIE	3
C5	357472	CAPACITOR, CER 18P/63G	PHI	1
C6	450529	CAPACITOR, ELCT, AL 6U8/25M	PHI	
C7	450529	CAPACITOR, ELCT, AL 6U8/25M	PHI	
C8	450510	CAPACITOR, CER 100N/63S	SIE	
C9	450529	CAPACITOR, ELCT, AL 6U8/25M	PHI	
C103	357480	CAPACITOR, CER 22P/63G	PHI	1
C105	357391	CAPACITOR, CER 4P7/63C	PHI	1
C106	450529	CAPACITOR, ELCT, AL 6U8/25M	PHI	
H1	349135	HEAT SINK	FHS	1
H2	218944	DISC DISTANCE T05	JMY	1
L1	375330	COIL, CHOKE IM2 U22/K	DAE	1
L3	394270	COIL, CHOKE IM2 220U/K	DAE	1
MP1	394742	STAY NUT 4T22733	EMK	4
Q1	362514	TRANSISTOR, NPN 2N5109	RCA	1
Q9	273899	TRANSISTOR, NPN BC171	ITT	1
R1	240214	RESISTOR, CARB 82R/0,25J	PHI	1
R2	240451	RESISTOR, CARB 2K2/0,25J	PHI	1
R3	240419	RESISTOR, CARB 1K2/0,25J	PHI	1
R4	240265	RESISTOR, CARB 200R/0,25J	PHI	1
R5		NOT USED		
R74	240400	RESISTOR, CARB 1K0/0,25J	PHI	1
T1	451886	TRAFO	EMK	1
VR1	362727	DIODE, SD, ZENER ZPD 13V/0,5J	ITT	1

Table 6.2 Replaceable Parts (cont'd)

		TITLE FRONT-END 1. MIXER	PARTS LIST	
REF DES	DRA PART NO	NOMENCLATURE OR DESCRIPTION	MFR CODE	QTY
FIND NO				
1	448230	PRINTED WIRING BOARD	EMK	1
2	448206	ELECTRICAL SCHEMATIC DIAGRAM		REF
3	448206	COMPONENT LOCATION DRAWING		REF
C27	357553	CAPACITOR, CER 82P/63G	PHI	1
C28	357472	CAPACITOR, CER 18P/63G	PHI	1
C29	357480	CAPACITOR, CER 22P/63G	PHI	1
C30	357588	CAPACITOR, CER 120P/63G	PHI	1
C31	357596	CAPACITOR, CER 150P/63G	PHI	1
L14	393967	COIL, CHOKE IM2 U15/K	DAE	1
L15	450391	COIL, CHOKE IM2 U39/K	DAE	1
L16	450405	COIL, CHOKE IM2 U68/K	DAE	1
L17	357820	COIL, CHOKE IM2 2U2/K	DAE	1
MP1	394742	STAY NUT 4T22733	EMK	4
R22	240192	RESISTOR, CARB 51R/0,25J	PHI	1
U1	362530	INTEGRATED CKT, HYBRID SRA3H	MCL	1

Table 6.2 Replaceable Parts (cont'd)

		TITLE	PARTS LIST	
		FRONT-END LO AMPLIFIER		
REF DES	DRA PART NO	NOMENCLATURE OR DESCRIPTION	MFR CODE	QTY
FIND NO				
1	448257	PRINTED WIRING BOARD	EMK	1
2	448206	ELECTRICAL SCHEMATIC DIAGRAM		REF
3	448206	COMPONENT LOCATION DRAWING		REF
C10	358959	CAPACITOR, CER 1N0/100K	PHI	6
C11	358959	CAPACITOR, CER 1N0/100K	PHI	
C12	357642	CAPACITOR, CER 10N/100S	PHI	4
C13	358959	CAPACITOR, CER 1N0/100K	PHI	
C14	357642	CAPACITOR, CER 10N/100S	PHI	
C15	357537	CAPACITOR, CER 56P/63G	PHI	1
C16	358959	CAPACITOR, CER 1N0/100K	PHI	
C17	358959	CAPACITOR, CER 1N0/100K	PHI	
C18	357642	CAPACITOR, CER 10N/100S	PHI	
C19	357642	CAPACITOR, CER 10N/100S	PHI	
C20	358959	CAPACITOR, CER 1N0/100K	PHI	
C21	357480	CAPACITOR, CER 22P/63G	PHI	1
C22	357383	CAPACITOR, CER 3P9/63C	PHI	1
C23	357499	CAPACITOR, CER 27P/63G	PHI	1
C24	357464	CAPACITOR, CER 15P/63G	PHI	1
C25	357413	CAPACITOR, CER 6P8/63C	PHI	2
C26	357413	CAPACITOR, CER 6P8/63C	PHI	
H1	386847	HEAT SINK		1
H2	349135	HEAT SINK	FHS	1
H3	218944	DISC DISTANCE T05	JMY	1
H4	218952	DISC DISTANCE T018	JMY	1
L4	357820	COIL, CHOKE IM2 2U2/K	DAE	4
L5	357820	COIL, CHOKE IM2 2U2/K	DAE	
L6	357820	COIL, CHOKE IM2 2U2/K	DAE	
L7	357820	COIL, CHOKE IM2 2U2/K	DAE	
L8	375330	COIL, CHOKE IM2 U22/K	DAE	3
L9	375330	COIL, CHOKE IM2 U22/K	DAE	
L10	394335	COIL, CHOKE IM2 U1/K	DAE	1
L11	393967	COIL, CHOKE IM2 U15/K	DAE	1
L12	375330	COIL, CHOKE IM2 U22/K	DAE	
L13	363944	COIL, CHOKE	PHI	1

Table 6.2 Replaceable Parts (cont'd)

		TITLE	PARTS LIST	
		FRONT-END LO AMPLIFIER		
REF DES	DRA PART NO	NOMENCLATURE OR DESCRIPTION	MFR CODE	QTY
FIND NO				
MP1	394742	STAY NUT 4T22733	EMK	4
Q2	357804	TRANSISTOR, NPN BFX89	PHI	1
Q3	362514	TRANSISTOR, NPN 2N5109	RCA	1
R6	240435	RESISTOR, CARB 1K8/0,25J	PHI	1
R7	450979	RESISTOR, CARB 360R/0,25J	PHI	2
R8	240478	RESISTOR, CARB 2K7/0,25J	PHI	1
R9	240397	RESISTOR, CARB 820R/0,25J	PHI	1
R10	240133	RESISTOR, CARB 24R/0,25J	PHI	1
R11	240273	RESISTOR, CARB 240R/0,25J	PHI	2
R12	240346	RESISTOR, CARB 470R/0,25J	PHI	1
R13	240265	RESISTOR, CARB 200R/0,25J	PHI	2
R14	240443	RESISTOR, CARB 2K0/0,25J	PHI	1
R15	240419	RESISTOR, CARB 1K2/0,25J	PHI	1
R16	450979	RESISTOR, CARB 360R/0,25J	PHI	
R17	240117	RESISTOR, CARB 18R/0,25J	PHI	2
R18	240117	RESISTOR, CARB 18R/0,25J	PHI	
R19	240273	RESISTOR, CARB 240R/0,25J	PHI	
R20	240265	RESISTOR, CARB 200R/0,25J	PHI	
R21	240192	RESISTOR, CARB 51R/0,25J	PHI	1

Table 6.2 Replaceable Parts (cont'd)

		TITLE	PARTS LIST	
		FRONT-END 1. IF AMPLIFIER		
REF DES	DRA PART NO	NOMENCLATURE OR DESCRIPTION	MFR CODE	QTY
FIND NO				
1	448273	PRINTED WIRING BOARD	EMK	1
2	448206	ELECTRICAL SCHEMATIC DIAGRAM		REF
3	448206	COMPONENT LOCATION DRAWING		REF
C32	357472	CAPACITOR, CER 18P/63G	PHI	1
C33	357480	CAPACITOR, CER 22P/63G	PHI	1
C34	373419	CAPACITOR, VAR 18P/100	PHI	1
C35	357502	CAPACITOR, CER 33P/63G	PHI	1
C36		NOT USED		
C37		NOT USED		
C38	450510	CAPACITOR, CER 100N/63S	SIE	5
C39	450510	CAPACITOR, CER 100N/63S	SIE	
C40	358959	CAPACITOR, CER 1N0/100K	PHI	3
C41	450510	CAPACITOR, CER 100N/63S	SIE	
C42	358959	CAPACITOR, CER 1N0/100K	PHI	
C43	357383	CAPACITOR, CER 3P9/63C	PHI	1
C44	357456	CAPACITOR, CER 12P/63G	PHI	1
C45	450510	CAPACITOR, CER 100N/63S	SIE	
C46	358959	CAPACITOR, CER 1N0/100K	PHI	
C47	450510	CAPACITOR, CER 100N/63S	SIE	
CR1	344966	DIODE, SI 1N4148	ITT	1
H1	349097	HEAT SINK		1
H2	349135	HEAT SINK		1
H3	373362	DISC DISTANCE T05	SEF	1
H4	218944	DISC DISTANCE T05	JMY	1
J5	358665	CONNECTOR RF 82SMB50-01	SUH	1
L18	375330	COIL, CHOKE IM2 U22/K	DAE	4
L19	375330	COIL, CHOKE IM2 U22/K	DAE	
L20	375330	COIL, CHOKE IM2 U22/K	DAE	
L21	375330	COIL, CHOKE IM2 U22/K	DAE	
L22	357820	COIL, CHOKE IM2 2U2/K	DAE	1
L23	392294	COIL, CHOKE IM2 10U/K	DAE	1

Table 6.2 Replaceable Parts (cont'd)

		TITLE FRONT-END 1. IF AMPLIFIER		PARTS LIST	
REF DES	DRA PART NO	NOMENCLATURE OR DESCRIPTION	MFR CODE	QTY	
FIND NO					
MP1	394742	STAY NUT 4T2273	EMK	4	
Q4	273899	TRANSISTOR, NPN BC171	ITT	1	
Q5	448710	TRANSISTOR, DUAL-J-FET U431	SLX	1	
Q6	362514	TRANSISTOR, NPN 2N5109	RCA	1	
R23	371033	RESISTOR, FILM 100R/0,125F	VIT	3	
R24	371033	RESISTOR, FILM 100R/0,125F	VIT		
R25	458260	RESISTOR, VAR 20R/0,75	BOU	1	
R26	240443	RESISTOR, CARB 2K0/0,25J	PHI	1	
R27	240419	RESISTOR, CARB 1K2/0,25J	PHI	3	
R28	240419	RESISTOR, CARB 1K2/0,25J	PHI		
R29		NOT USED			
R30	240567	RESISTOR, CARB 10K/0,25J	PHI	1	
R31	240222	RESISTOR, CARB 100R/0,25J	PHI	1	
R32	240451	RESISTOR, CARB 2K2/0,25J	PHI	1	
R33	240109	RESISTOR, CARB 10R/0,25J	PHI	1	
R34	240214	RESISTOR, CARB 82R/0,25J	PHI	1	
R35	240419	RESISTOR, CARB 1K2/0,25J	PHI		
R36	371033	RESISTOR, FILM 100R/0,125 F	VIT		
T2	451940	TRAFO	EMK	1	
T3	451967	TRAFO	EMK	1	

Table 6.2 Replaceable Parts (cont'd)

		TITLE	PARTS LIST	
		FRONT-END 75 MHZ AGC AMPLIFIER		
REF DES	DRA PART NO	NOMENCLATURE OR DESCRIPTION	MFR CODE	QTY
FIND NO				
1	448303	PRINTED WIRING BOARD	EMK	1
2	448206	ELECTRICAL SCHEMATIC DIAGRAM		REF
3	448206	COMPONENT LOCATION DRAWING		REF
C48	358959	CAPACITOR, CER 1N/100K	PHI	3
C49	357642	CAPACITOR, CER 10N/100S	PHI	4
C50	357642	CAPACITOR, CER 10N/100S	PHI	
C51	357561	CAPACITOR, CER 100P/63G	PHI	2
C52	357642	CAPACITOR, CER 10N/100S	PHI	
C53	357642	CAPACITOR, CER 10N/100S	PHI	
C54	385646	CAPACITOR, CER 2P7/100C	PHI	1
C55	358959	CAPACITOR, CER 1N/100K	PHI	
C56	357561	CAPACITOR, CER 100P/63G	PHI	
C57	357545	CAPACITOR, CER 68P/63G	PHI	1
C58	357472	CAPACITOR, CER 18P/63G	PHI	1
C103	358959	CAPACITOR, CER 1N/100K	PHI	
CR2	344966	DIODE, SI 1N4148	ITT	3
CR3	344966	DIODE, SI 1N4148	ITT	
CR12	344966	DIODE, SI 1N4148	ITT	
E10	376213	FERRITE BEAD	PHI	1
H1	450065	SCREEN SHIELD	VGT	2
H2	450073	SCREEN SHIELD	VGT	1
L24	451991	COIL	EMK	2
L25	451991	COIL	EMK	
L41	451983	COIL	EMK	
MP1	394742	STAY NUT 4T22733	EMK	4
Q7	450235	TRANSISTOR, DUAL-GATE-D-MOS SN306	PHI	1
Q9	273899	TRANSISTOR, NPN BC171	ITT	1

Table 6.2 Replaceable Parts (cont'd)

		TITLE	PARTS LIST	
		FRONT-END 75 MHZ AGC AMPLIFIER		
REF DES	DRA PART NO	NOMENCLATURE OR DESCRIPTION	MFR CODE	QTY
FIND NO				
R37	324191	RESISTOR, CARB 7K5/0,25J	PHI	1
R38	240214	RESISTOR, CARB 82R/0,25J	PHI	1
R39	240494	RESISTOR, CARB 3K9/0,25J	PHI	1
R40	240605	RESISTOR, CARB 15K/0,25J	PHI	1
R41	240567	RESISTOR, CARB 10K/0,25J	PHI	3
R42	372064	RESISTOR, CARB 9K1/0,25J	PHI	1
R43	391980	RESISTOR, VAR 2K0/0,75K	BOU	1
R44	240443	RESISTOR, CARB 2K0/0,25J	PHI	1
R45	240516	RESISTOR, CARB 4K7/0,25J	PHI	1
R46	240567	RESISTOR, CARB 10K/0,25J	PHI	
R47	324221	RESISTOR, CARB 2K4/0,25J	PHI	1
R48	240567	RESISTOR, CARB 10K/0,25J	PHI	
R49	240524	RESISTOR, CARB 5K6/0,25J	PHI	2
R50	240141	RESISTOR, CARB 27R/0,25J	PHI	2
R51	240141	RESISTOR, CARB 27R/0,25J	PHI	
R70	240648	RESISTOR, CARB 27K/0,25J	PHI	1
R71	240265	RESISTOR, CARB 200R/0,25J	PHI	1
R72	240397	RESISTOR, CARB 820R/0,25J	PHI	1
R73	240524	RESISTOR, CARB 5K6/0,25J	PHI	
RT1	458252	RESISTOR, NTC 4K7/K	SIE	1
T4	451924	TRAFO	EMK	1
TP9	231304	TEST POINT		1
U2	450294	INTEGRATED CKT TL082CP	TII	1

Table 6.2 Replaceable Parts (cont'd)

		TITLE	PARTS LIST	
		FRONT-END 2. MIXER		
REF DES	DRA PART NO	NOMENCLATURE OR DESCRIPTION	MFR CODE	QTY
FIND NO				
1	448338	PRINTED WIRING BOARD	EMK	1
2	448206	ELECTRICAL SCHEMATIC DIAGRAM		REF
3	448206	COMPONENT LOCATION DRAWING		REF
C59	357510	.CAPACITOR, CER 39P/63G	PHI	2
C60	357510	CAPACITOR, CER 39P/63G	PHI	
L27	394335	COIL, CHOKE IM2 U1/K	DAE	2
L28	394335	COIL, CHOKE IM2 U1/K	DAE	
MP1	394742	STAY NUT 4T22733	EMK	4
R52	240192	RESISTOR, CARB 51R/0,25J	PHI	2
R53	240192	RESISTOR, CARB 51R/0,25J	PHI	
U3	454079	INTEGRATED CKT HYBRID CM-1	VAR	1

Table 6.2 Replaceable Parts (cont'd)

		TITLE FRONT-END 2. IF AMPLIFIER	PARTS LIST	
REF DES FIND NO	DRA PART NO	NOMENCLATURE OR DESCRIPTION	MFR CODE	QTY
1	448354	PRINTED WIRING BOARD	EMK	1
2	448206	ELECTRICAL SCHEMATIC DIAGRAM		REF
3	448206	COMPONENT LOCATION DRAWING		REF
C61	357634	CAPACITOR, CER 2N2/100K	PHI	2
C62	357634	CAPACITOR, CER 2N2/100K	PHI	
C63	448834	CAPACITOR, PLST 1N5/630F	SIE	1
C64	450510	CAPACITOR, CER 100N/63S	SIE	3
C65	450510	CAPACITOR, CER 100N/63S	SIE	
C66	450510	CAPACITOR, CER 100N/63S	SIE	
L29	393975	COIL, CHOKE IM2 5U6K	DAE	2
L30	393975	COIL, CHOKE IM2 5U6K	DAE	
MP1	394742	STAY NUT 4T22733	EMK	4
Q8	357901	TRANSISTOR, N-CHANNEL-J-FET J310	SLX	1
R54	240192	RESISTOR, CARB 51R/0,25J	PHI	2
R55	240192	RESISTOR, CARB 51R/0,25J	PHI	
R56	240168	RESISTOR, CARB 33R/0,25J	PHI	1
R57	240400	RESISTOR, CARB 1K0/0,25J	PHI	1
R58	240109	RESISTOR, CARB 10R/0,25J	PHI	1
R59	240230	RESISTOR, CARB 120R/0,25J	PHI	1
T5	451916	TRAFO	EMK	1
T6	451894	TRAFO	EMK	1

Table 6.2 Replaceable Parts (cont'd)

		TITLE	PARTS LIST	
		PRESELECTOR MARINE EXCL. DUPLEX		
REF DES	DRA PART NO	NOMENCLATURE OR DESCRIPTION	MFR CODE	QTY
FIND NO				
1	448370	PRINTED WIRING BOARD	EMK	1
2	458155	ELECTRICAL SCHEMATIC DIAGRAM		REF
3	458155	COMPONENT LOCATION DRAWING		REF
C1	202975	CAPACITOR, PLST 1U0/100K	PHI	5
C2	393959	CAPACITOR, CER 100N/50M	VAD	4
C3	357510	CAPACITOR, CER 39P/100G	PHI	1
C4	357642	CAPACITOR, CER 10N/100S	PHI	1
C5	450510	CAPACITOR, CER 100N/63S	SIE	14
C6	202975	CAPACITOR, PLST 1U0/100K	PHI	
C7		NOT USED		
C8	450510	CAPACITOR, CER 100N/63S	SIE	
C9	357421	CAPACITOR, CER 8P2/100G	PHI	2
C10	450510	CAPACITOR, CER 100N/63S	SIE	
C11		NOT USED		
C12		NOT USED		
C13		NOT USED		
C14		NOT USED		
C15		NOT USED		
C16		NOT USED		
C17		NOT USED		
C18		NOT USED		
C19		NOT USED		
C20	450510	CAPACITOR, CER 100N/63S	SIE	
C21	448958	CAPACITOR, VAR 2 x 330P/100F	HEE	1
C22	450510	CAPACITOR, CER 100N/63S	SIE	
C23	361356	CAPACITOR, CER 2P2/500G	PHI	2
C24	357421	CAPACITOR, CER 8P2/100G	PHI	
C25	437395	CAPACITOR, CER 220P/100G	PHI	1
C26	393959	CAPACITOR, CER 100N/50M	VAD	
C27	361356	CAPACITOR, CER 2P2/500G	PHI	
C28	357448	CAPACITOR, CER 10P/100G	PHI	1
C29	393959	CAPACITOR, CER 100N/50M	VAD	
C30	393959	CAPACITOR, CER 100N/50M	VAD	
C31	448842	CAPACITOR, PLST 1N8/630F	SIE	2
C32	450510	CAPACITOR, CER 100N/63S	SIE	
C33	448826	CAPACITOR, PLST 820P/630F	SIE	1
C34	357588	CAPACITOR, CER 120P/100G	PHI	1
C35	357545	CAPACITOR, CER 68P/100G	PHI	3
C36	450510	CAPACITOR, CER 100N/63S	SIE	

Table 6.2 Replaceable Parts (cont'd)

REF DES		DRA PART NO	NOMENCLATURE OR DESCRIPTION	MFR CODE	QTY
FIND NO					
		TITLE PRESELECTOR MARINE EXCL. DUPLEX		PARTS LIST	
C37		448869	CAPACITOR, PLST 2N4/630F	SIE	2
C38		448818	CAPACITOR, PLST 470P/630F	SIE	1
C39		448869	CAPACITOR, PLST 2N4/630F	SIE	
C40		357529	CAPACITOR, CER 47P/100G	PHI	1
C41		357456	CAPACITOR, CER 12P/100G	PHI	1
C42		450510	CAPACITOR, CER 100N/63S	SIE	
C43		396389	CAPACITOR, CER 680P/40M	FRP	1
C44		448834	CAPACITOR, PLST 1N5/630F	SIE	2
C45		448834	CAPACITOR, PLST 1N5/630F	SIE	
C46		448842	CAPACITOR, PLST 1N8/630F	SIE	
C47			NOT USED		
C48			NOT USED		
C49		358959	CAPACITOR, CER 1N0/100K	PHI	1
C50			NOT USED		
C51			NOT USED		
C52			NOT USED		
C53			NOT USED		
C54			NOT USED		
C55			NOT USED		
C56			NOT USED		
C57			NOT USED		
C58			NOT USED		
C59			NOT USED		
C60			NOT USED		
C61			NOT USED		
C62			NOT USED		
C63		450510	CAPACITOR, CER 100N/63S	SIE	
C64		450510	CAPACITOR, CER 100N/63S	SIE	
C65		202975	CAPACITOR, PLST 1U0/100K	PHI	
C66		202975	CAPACITOR, PLST 1U0/100K	PHI	
C67		450510	CAPACITOR, CER 100N/63S	SIE	
C68		357545	CAPACITOR, CER 68P/100G	PHI	
C69		357464	CAPACITOR, CER 15P/100G	PHI	2
C70		357596	CAPACITOR, CER 150P/100G	PHI	1
C71		357464	CAPACITOR, CER 15P/100F	PHI	
C72		357545	CAPACITOR, CER 68P/100G	PHI	
C73		450510	CAPACITOR, CER 100N/63S	SIE	
C74		450510	CAPACITOR, CER 100N/63S	SIE	
C75		202975	CAPACITOR, PLST 1U0/100K	PHI	
C76		450510	CAPACITOR, CER 100N/63S	SIE	
C77		450529	CAPACITOR, ELCT, AL 6U8/25S	PHI	3

Table 6.2 Replaceable Parts (cont'd)

		TITLE	PARTS LIST	
		PRESELECTION MARINE EXCL. DUPLEX		
REF DES	DRA PART NO	NOMENCLATURE OR DESCRIPTION	MFR CODE	QTY
FIND NO				
C78	450529	CAPACITOR, ELCT, AL 6U8/25S	PHI	
C79	450529	CAPACITOR, ELCT, AL 6U8/25S	PHI	
CR1	345865	DIODE, SI BYX71/350	PHI	2
CR2	345865	DIODE, SI BYX71/350	PHI	
CR3		NOT USED		
CR4	450987	DIODE, SI 1N4150	PHI	4
CR5	450987	DIODE, SI 1N4150	PHI	
CR6		NOT USED		
CR7		NOT USED		
CR8		NOT USED		
CR9		NOT USED		
CR10		NOT USED		
CR11	450944	DIODE, SI 1S921	FAI	5
CR12	450944	DIODE, SI 1S921	FAI	
CR13		NOT USED		
CR14	450944	DIODE, SI 1S921	FAI	
CR15		NOT USED		
CR16	450944	DIODE, SI 1S921	FAI	
CR17	450944	DIODE, SI 1S921	FAI	
CR18		NOT USED		
CR19	450987	DIODE, SI 1N4150	PHI	
CR20	450987	DIODE, SI 1N4150	PHI	
CR21		NOT USED		
CR22		NOT USED		
CR23	344966	DIODE, SI 1N4148	ITT	11
CR24	344966	DIODE, SI 1N4148	ITT	
CR25	344966	DIODE, SI 1N4148	ITT	
CR26	344966	DIODE, SI 1N4148	ITT	
CR27	344966	DIODE, SI 1N4148	ITT	
CR28		NOT USED		
CR29	344966	DIODE, SI 1N4148	ITT	
CR30	344966	DIODE, SI 1N4148	ITT	
CR31	344966	DIODE, SI 1N4148	ITT	
CR32	344966	DIODE, SI 1N4148	ITT	
CR33	344966	DIODE, SI 1N4148	ITT	
CR34	344966	DIODE, SI 1N4148	ITT	

Table 6.2 Replaceable Parts (cont'd)

		TITLE	PARTS LIST	
		PRESELECTOR MARINE EXCL. DUPLEX		
REF DES	DRA PART NO	NOMENCLATURE OR DESCRIPTION	MFR CODE	QTY
FIND NO				
J1	451002	CONNECTOR, COAX BNC 50 OHM	AMP	1
J2	361399	CONNECTOR, RF 85SMB50-01	SUH	1
H1	458694	SCREW M 2,5 x 5 CHM		5
H2	450553	SELF TAPPING SCREW		4
H3	435686	POINTED SCREW		6
H4	454729	KNOB Ø 14,5	ELM	1
H5	454737	KNOB, CAB Ø 11	ELM	1
K1		NOT USED		
K2		NOT USED		
K3		NOT USED		
K4		NOT USED		
K5	359521	RELAY, SPSTNO 15V2K	ETI	23
K6	359521	RELAY, SPSTNO 15V2K	ETI	
K7	359521	RELAY, SPSTNO 15V2K	ETI	
K8	359521	RELAY, SPSTNO 15V2K	ETI	
K9	359521	RELAY, SPSTNO 15V2K	ETI	
K10	359521	RELAY, SPSTNO 15V2K	ETI	
K11	359521	RELAY, SPSTNO 15V2K	ETI	
K12	359521	RELAY, SPSTNO 15V2K	ETI	
K13	359521	RELAY, SPSTNO 15V2K	ETI	
K14	359521	RELAY, SPSTNO 15V2K	ETI	
K15	359521	RELAY, SPSTNO 15V2K	ETI	
K16	359521	RELAY, SPSTNO 15V2K	ETI	
K17	359521	RELAY, SPSTNO 15V2K	ETI	
K18	359521	RELAY, SPSTNO 15V2K	ETI	
K19	359521	RELAY, SPSTNO 15V2K	ETI	
K20	359521	RELAY, SPSTNO 15V2K	ETI	
K21	359521	RELAY, SPSTNO 15V2K	ETI	
K22	359521	RELAY, SPSTNO 15V2K	ETI	
K23	359521	RELAY, SPSTNO 15V2K	ETI	
K24	359521	RELAY, SPSTNO 15V2K	ETI	
K25	359521	RELAY, SPSTNO 15V2K	ETI	
K26	359521	RELAY, SPSTNO 15V2K	ETI	
K27	359521	RELAY, SPSTNO 15V2K	ETI	
L1	457590	COIL, RF	EMK	1
L2		NOT USED		
L3		NOT USED		

Table 6.2 Replaceable Parts (cont'd)

REF DES		DRA PART NO	NOMENCLATURE OR DESCRIPTION	MFR CODE	QTY
FIND NO					
L4			NOT USED		
L5			NOT USED		
L6			NOT USED		
L7			NOT USED		
L8			NOT USED		
L9			NOT USED		
L10		451746	COIL, RF	EMK	2
L11		450030	COIL, RF U15/K	PRA	1
L12		451746	COIL, RF	EMK	
L13		451703	COIL, RF	EMK	2
L14		450006	COIL, RF 33U/K	PRA	1
L15		451703	COIL, RF	EMK	
L16		451665	COIL, RF	EMK	1
L17		450014	COIL, RF 3U3/K	PRA	2
L18		450014	COIL, RF 3U3/K	PRA	
L19		450057	COIL, RF 2U7/K	DAE	2
L20		450057	COIL, RF 2U7/K	DAE	
L21		363294	COIL, RF 47U/J	DAE	1
L22		450049	COIL, RF 56U/J	DAE	1
L23		451738	COIL, RF	EMK	1
L24		448982	COIL, RF 330U/J	PRA	2
L25		451711	COIL, RF	EMK	1
L26		448974	COIL, RF 2M0/J	PRA	1
L27		457752	COIL, RF	EMK	1
L28		404411	COIL, RF 4U7/K	PRA	1
L29		448982	COIL, RF 330U/J	PRA	
L30		448966	COIL, RF 10M/J	PRA	2
L31		458201	COIL, RF 3U3/K	DAE	2
L32			NOT USED		
L33			NOT USED		
L34			NOT USED		
L35			NOT USED		
L36			NOT USED		
L37			NOT USED		
L38			NOT USED		
L39			NOT USED		
L40			NOT USED		
L41			NOT USED		
L42			NOT USED		
L43		448990	COIL, RF 100U/K	PRA	4
L44		448966	COIL, RF 10M/J	PRA	

Table 6.2 Replaceable Parts (cont'd)

REF DES		DRA PART NO	NOMENCLATURE OR DESCRIPTION	MFR CODE	QTY
FIND NO					
		TITLE PRESELECTOR MARINE EXCL. DUPLEX		PARTS LIST	
L45		450022	COIL, RF U33/K	PRA	2
L46		450022	COIL, RF U33/K	PRA	
L47		448990	COIL, RF 100U/K	PRA	
L48		448990	COIL, RF 100U/K	PRA	
L49		448990	COIL, RF 100U/K	PRA	
L50		458201	COIL, RF 3U3/K	DAE	
MP1		459348	REAR PLATE	EMK	1
MP2		448095	PC RETAINER	EMK	1
MP3		260819	THUMB SCREW 5T18978	EMK	2
MP4		450693	AXLE SHAFT RETAINER 1	EMK	1
MP5		458198	AXLE SHAFT RETAINER 2	EMK	1
MP6		450707	SHAFT Ø12	EMK	1
MP7		450715	SPRING	EMK	1
MP8		450723	SWITCH DISC	EMK	1
MP9		450731	SHAFT Ø 6,35	EMK	1
MP10		458228	COUPLING	EMK	1
MP11		459356	CONTACT SPRING 1	EMK	1
MP12		459364	CONTACT SPRING 2	EMK	1
Q1		273899	TRANSISTOR NPN BC171	ITT	1
R1		380393	RESISTOR, CARB 270K/0,25J	PHI	16
R2		240400	RESISTOR, CARB 1K0/0,25J	PHI	2
R3		380393	RESISTOR, CARB 270K/0,25J	PHI	
R4		380393	RESISTOR, CARB 270K/0,25J	PHI	
R5		240524	RESISTOR, CARB 5K6/0,25J	PHI	1
R6		241458	RESISTOR, CARB 1K0/0,25J	PHI	1
R7		240850	RESISTOR, CARB 560K/0,25J	PHI	1
R8		380393	RESISTOR, CARB 270K/0,25J	PHI	
R9		380393	RESISTOR, CARB 270K/0,25J	PHI	
R10		240486	RESISTOR, CARB 3K3/0,25J	PHI	1
R11		240478	RESISTOR, CARB 2K7/0,25J	PHI	1
R12			NOT USED		
R13			NOT USED		
R14		240516	RESISTOR, CARB 4K7/0,25J	PHI	3
R15		240435	RESISTOR, CARB 1K8/0,25J	PHI	1
R16		380393	RESISTOR, CARB 270K/0,25J	PHI	
R17		240281	RESISTOR, CARB 270R/0,25J	PHI	1
R18		240702	RESISTOR, CARB 56K/0,25J	PHI	3

Table 6.2 Replaceable Parts (cont'd)

		TITLE PRESELECTOR MARINE EXCL. DUPLEX	PARTS LIST	
REF DES	DRA PART NO	NOMENCLATURE OR DESCRIPTION	MFR CODE	QTY
FIND NO				
R19	240702	RESISTOR, CARB 56K/0,25J	PHI	
R20	240516	RESISTOR, CARB 4K7/0,25J	PHI	
R21	240702	RESISTOR, CARB 56K/0,25J	PHI	
R22	240222	RESISTOR, CARB 100R/0,25J	PHI	1
R23	240656	RESISTOR, CARB 33K/0,25J	PHI	2
R24	363057	RESISTOR, CARB 2M2/0,25J	PHI	2
R25	363057	RESISTOR, CARB 2M2/0,25J	PHI	
R26	240656	RESISTOR, CARB 33K/0,25J	PHI	
R27		NOT USED		
R28	380393	RESISTOR, CARB 270K/0,25J	PHI	
R29	240109	RESISTOR, CARB 10R/0,25J	PHI	4
R30		NOT USED		
R31	240400	RESISTOR, CARB 1K0/0,25J	PHI	
R32	240109	RESISTOR, CARB 10R/0,25J	PHI	
R33		NOT USED		
R34	380393	RESISTOR, CARB 270K/0,25J	PHI	
R35	380393	RESISTOR, CARB 270K/0,25J	PHI	
R36	240621	RESISTOR, CARB 22K/0,25J	PHI	2
R37	380393	RESISTOR, CARB 270K/0,25J	PHI	
R38	380393	RESISTOR, CARB 270K/0,25J	PHI	
R39	240621	RESISTOR, CARB 22K/0,25J	PHI	
R40	361992	RESISTOR, CARB 68R/0,25J	PHI	1
R41		NOT USED		
R42		NOT USED		
R43		NOT USED		
R44		NOT USED		
R45		NOT USED		
R46		NOT USED		
R47		NOT USED		
R48		NOT USED		
R49		NOT USED		
R50	240109	RESISTOR, CARB 10R/0,25J	PHI	
R51	240206	RESISTOR, CARB 56R/0,25J	PHI	1
R52	240745	RESISTOR, CARB 100K/0,25J	PHI	1
R53	240516	RESISTOR, CARB 4K7/0,25J	PHI	
R54	240109	RESISTOR, CARB 10R/0,25J	PHI	
R55	380393	RESISTOR, CARB 270K/0,25J	PHI	
R56	380393	RESISTOR, CARB 270K/0,25J	PHI	
R57	380393	RESISTOR, CARB 270K/0,25J	PHI	
R58		NOT USED		
R59		NOT USED		

Table 6.2 Replaceable Parts (cont'd)

REF DES		DRA PART NO	NOMENCLATURE OR DESCRIPTION	MFR CODE	QTY
FIND NO					
			TITLE PRESELECTOR MARINE EXCL. DUPLEX	PARTS LIST	
R60			NOT USED		
R61			NOT USED		
R62		380393	RESISTOR, CARB 270K/0,25J	PHI	
R63		380393	RESISTOR, CARB 270K/0,25J	PHI	
R64		240958	RESISTOR, CARB 1R0/0,5J	PHI	1
S1		451010	SWITCH, SPDT 10A/250V	CHE	1
U1		433683	INTEGRATED CKT SN74LS138	TII	1
U2		451029	INTEGRATED CKT SN74LS377	TII	1
U3		404586	INTEGRATED CKT SN7445	TII	2
U4		404586	INTEGRATED CKT SN7445	TII	
U5		433535	INTEGRATED CKT SN74LS04	TII	1
U6		362131	INTEGRATED CKT SN7406	TII	1
VR1		450995	DIODE, SD, ZENER ZPD8V2/1K IN4738	MOT	1
VR2		228869	DIODE, SD, ZENER ZPD7V5/0,5J	ITT	1
VR3		228796	DIODE, SD, ZENER ZPD12V/0,5J	ITT	1
VR4		361488	DIODE, SD, ZENER ZPD3V9/0,5J	ITT	1
W1		225495	JUMPER, TINNED CU WIRE 0,7		0,001

Table 6.2 Replaceable Parts (cont'd)

		TITLE IF/AF	PARTS LIST	
REF DES	DRA PART NO	NOMENCLATURE OR DESCRIPTION	MFR CODE	QTY
FIND NO				
1	448435	PRINTED WIRING BOARD	EMK	1
2	448443	ELECTRICAL SCHEMATIC DIAGRAM		REF
3	448443	COMPONENT LOCATION DRAWING		REF
C1	450510	CAPACITOR, CER 100N/63S	SIE	58
C2	448834	CAPACITOR, PLST 1N5/630F	SIE	3
C3	450510	CAPACITOR, CER 100N/63S	SIE	
C4	450510	CAPACITOR, CER 100N/63S	SIE	
C5	450510	CAPACITOR, CER 100N/63S	SIE	
C6	450510	CAPACITOR, CER 100N/63S	SIE	
C7	357588	CAPACITOR, CER 120P/63G	PHI	1
C8	448877	CAPACITOR, PLST 3N3/160F	SIE	4
C9	450510	CAPACITOR, CER 100N/63S	SIE	
C10	450529	CAPACITOR, ELCT, AL 6U8/25M	PHI	19
C11	450510	CAPACITOR, CER 100N/63S	SIE	
C12	450510	CAPACITOR, CER 100N/63S	SIE	
C13	358959	CAPACITOR, CER 1M/100K	PHI	1
C14	450510	CAPACITOR, CER 100N/63S	SIE	
C15	448877	CAPACITOR, PLST 3N3/160F	SIE	
C16	448877	CAPACITOR, PLST 3N3/160F	SIE	
C17	450510	CAPACITOR, CER 100N/63S	SIE	
C18	450510	CAPACITOR, CER 100N/63S	SIE	
C19	450510	CAPACITOR, CER 100N/63S	SIE	
C20	450510	CAPACITOR, CER 100N/63S	SIE	
C21	450510	CAPACITOR, CER 100N/63S	SIE	
C22	450510	CAPACITOR, CER 100N/63S	SIE	
C23	448834	CAPACITOR, PLST 1N5/630F	SIE	
C24	450510	CAPACITOR, CER 100N/63S	SIE	
C25	450510	CAPACITOR, CER 100N/63S	SIE	
C26	450510	CAPACITOR, CER 100N/63S	SIE	
C27	357642	CAPACITOR, CER 10N/100S	PHI	4
C28	448885	CAPACITOR, PLST 4N7/160F	SIE	1
C29	357642	CAPACITOR, CER 10N/100S	PHI	
C30	450510	CAPACITOR, CER 100N/63S	SIE	
C31	450529	CAPACITOR, ELCT, AL 6U8/25M	PHI	
C32	450529	CAPACITOR, ELCT, AL 6U8/25M	PHI	
C33	448893	CAPACITOR, PLST 5N1/160F	SIE	1
C34	448877	CAPACITOR, PLST 3N3/160F	SIE	
C35	448788	CAPACITOR, PLST 270P/630F	SIE	1
C36	450529	CAPACITOR, ELCT, AL 6U8/25M	PHI	
C37	450510	CAPACITOR, CER 100N/63S	SIE	

Table 6.2 Replaceable Parts (cont'd)

		TITLE IF/AF	PARTS LIST	
REF DES	DRA PART NO	NOMENCLATURE OR DESCRIPTION	MFR CODE	QTY
FIND NO				
C38	450529	CAPACITOR, ELCT, AL 6U8/25M	PHI	
C39	450529	CAPACITOR, ELCT, AL 6U8/25M	PHI	
C40	450529	CAPACITOR, ELCT, AL 6U8/25M	PHI	
C41	357650	CAPACITOR, CER 22N/40A	PHI	1
C42	357561	CAPACITOR, CER 100P/63G	PHI	1
C43	450529	CAPACITOR, ELCT, AL 6U8/25M	PHI	
C44	450529	CAPACITOR, ELCT, AL 6U8/25M	PHI	
C45	450510	CAPACITOR, CER 100N/63S	SIE	
C46	450510	CAPACITOR, CER 100N/63S	SIE	
C47	450510	CAPACITOR, CER 100N/63S	SIE	
C48	450529	CAPACITOR, ELCT, AL 6U8/25M	PHI	
C49	450510	CAPACITOR, CER 100N/63S	SIE	
C50	450510	CAPACITOR, CER 100N/63S	SIE	
C51	450510	CAPACITOR, CER 100N/63S	SIE	
C52	450510	CAPACITOR, CER 100N/63S	SIE	
C53	450510	CAPACITOR, CER 100N/63S	SIE	
C54	450510	CAPACITOR, CER 100N/63S	SIE	
C55	450510	CAPACITOR, CER 100N/63S	SIE	
C56	450510	CAPACITOR, CER 100N/63S	SIE	
C57	450510	CAPACITOR, CER 100N/63S	SIE	
C58	450529	CAPACITOR, ELCT, AL 6U8/25M	PHI	
C59	450510	CAPACITOR, CER 100N/63S	SIE	
C60	450510	CAPACITOR, CER 100N/63S	SIE	
C61	450510	CAPACITOR, CER 100N/63S	SIE	
C62	450510	CAPACITOR, CER 100N/63S	SIE	
C63	450510	CAPACITOR, CER 100N/63S	SIE	
C64	450510	CAPACITOR, CER 100N/63S	SIE	
C65	450510	CAPACITOR, CER 100N/63S	SIE	
C66	450529	CAPACITOR, ELCT, AL 6U8/25M	PHI	
C67	450510	CAPACITOR, CER 100N/63S	SIE	
C68	450510	CAPACITOR, CER 100N/63S	SIE	
C69	450510	CAPACITOR, CER 100N/63S	SIE	
C70	450510	CAPACITOR, CER 100N/63S	SIE	
C71	450510	CAPACITOR, CER 100N/63S	SIE	
C72	450510	CAPACITOR, CER 100N/63S	SIE	
C73	450510	CAPACITOR, CER 100N/63S	SIE	
C74	450510	CAPACITOR, CER 100N/63S	SIE	
C75	450529	CAPACITOR, ELCT, AL 6U8/25M	PHI	
C76	450510	CAPACITOR, CER 100N/63S	SIE	
C77	450510	CAPACITOR, CER 100N/63S	SIE	
C78	450510	CAPACITOR, CER 100N/63S	SIE	

Table 6.2 Replaceable Parts (cont'd)

		TITLE	PARTS LIST	
		IF/AF		
REF DES	DRA PART NO	NOMENCLATURE OR DESCRIPTION	MFR CODE	QTY
FIND NO				
C79	450510	CAPACITOR, CER 100N/63S-	SIE	
C80	450529	CAPACITOR, ELCT, AL 6U8/25M	PHI	
C81	450529	CAPACITOR, ELCT, AL 6U8/25M	PHI	
C82	450529	CAPACITOR, ELCT, AL 6U8/25M	PHI	
C83	450510	CAPACITOR, CER 100N/63S	SIE	
C84	450510	CAPACITOR, CER 100N/63S	SIE	
C85	357634	CAPACITOR, CER 2N2/100K	PHI	3
C86	357634	CAPACITOR, CER 2N2/100K	PHI	
C87	450529	CAPACITOR, ELCT, AL 6U8/25M	PHI	
C88	357634	CAPACITOR, CER 2N2/100K	PHI	
C89	357642	CAPACITOR, CER 10N/100S	PHI	
C90	450510	CAPACITOR, CER 100N/63S	SIE	
C91	450529	CAPACITOR, ELCT, AL 6U8/25M	PHI	
C92	448931	CAPACITOR, PLST 22N/160F	SIE	1
C93	448923	CAPACITOR, PLST 15N/160F	SIE	1
C94	448834	CAPACITOR, PLST 1N5/630F	SIE	
C95	450529	CAPACITOR, ELCT, AL 6U8/25M	PHI	
C96	450510	CAPACITOR, CER 100N/63S	SIE	
C97	450510	CAPACITOR, CER 100N/63S	SIE	
C98	450359	CAPACITOR, ELCT, AL 1U/25M	PHI	1
C99	450510	CAPACITOR, CER 100N/63S	SIE	
C100	450510	CAPACITOR, CER 100N/63S	SIE	
C101	357642	CAPACITOR, CER 10N/100S	PHI	
CR1	344966	DIODE, SI 1N4148	ITT	3
CR2	344966	DIODE, SI 1N4148	ITT	
CR3	344966	DIODE, SI 1N4148	ITT	
E1	376213	FERRITE BEAD	PHI	1
H1	458694	SCREW M 2,5 X 5 CHM		5
H2	230251	SLIDING LOCK POST D53018	CAN	1
H3	373362	IC PAD T05		2
H4	450065	SCREEN SHIELD	VGT	1
J1	361399	CONNECTOR, RF 85SMB50-01	SUH	1

Table 6.2 Replaceable Parts (cont'd)

		TITLE IF/AF	PARTS LIST	
REF DES	DRA PART NO	NOMENCLATURE OR DESCRIPTION	MFR CODE	QTY
FIND NO				
J2	USED ON W1	CONNECTOR, COAX BNC	SUH	
J3	USED ON W2	CONNECTOR, COAX SMB	SUH	
J4	373273	CONNECTOR, DE-9P-1A0N	CAN	1
L1		NOT USED		
L2	451975	COIL	EMK	1
L3	363944	COIL, CHOKE	PHI	3
L4	369944	COIL, CHOKE	PHI	
L5	369944	COIL, CHOKE	PHI	
MP1	460222	REAR PLATE	EMK	1
MP2	448095	PC RETAINER	EMK	1
MP3	260819	THUMB SCREW 5T18978	EMK	2
MP4	450901	SCREEN SHIELD	EMK	1
MP5	450928	SCREEN SHIELD	EMK	1
MP6	450936	SCREEN SHIELD	EMK	1
Q1	357901	TRANSISTOR, N-CHANNEL J-FET J310	SLX	2
Q2	388009	TRANSISTOR, DUAL-GATE MOS-FET 3N201	TII	1
Q3	273899	TRANSISTOR, NPN BC171	PHI	7
Q4	273899	TRANSISTOR, NPN BC171	PHI	
Q5	273899	TRANSISTOR, NPN BC171	PHI	
Q6	273899	TRANSISTOR, NPN BC171	PHI	
Q7	273899	TRANSISTOR, NPN BC171	PHI	
Q8	359157	TRANSISTOR, PNP BC251	PHI	1
Q9	357901	TRANSISTOR, N-CHANNEL J-FET J310	SLX	
Q10	273899	TRANSISTOR, NPN BC171	PHI	
Q11	273899	TRANSISTOR, NPN BC171	PHI	
R1	240109	RESISTOR, CARB 10R/0,25J	PHI	11
R2	240206	RESISTOR, CARB 56R/0,25J	PHI	2
R3	240230	RESISTOR, CARB 120R/0,25J	PHI	4
R4	328545	RESISTOR, CARB 220R/0,25J	PHI	3
R5	240648	RESISTOR, CARB 27K/0,25J	PHI	3
R6	328545	RESISTOR, CARB 220R/0,25J	PHI	
R7	240516	RESISTOR, CARB 4K7/0,25J	PHI	6
R8	240761	RESISTOR, CARB 120K/0,25J	PHI	1

Table 6.2 Replaceable Parts (cont'd)

		TITLE	PARTS LIST	
		IF/AF		
REF DES	DRA PART NO	NOMENCLATURE OR DESCRIPTION	MFR CODE	QTY
FIND NO				
R9	240613	RESISTOR, CARB 18K/0,25J	PHI	2
R10	240605	RESISTOR, CARB 15K/0,25J	PHI	2
R11	363227	RESISTOR, VAR 10K/0,5K	BOU	1
R12	240427	RESISTOR, CARB 1K5/0,25K	PHI	5
R13	240109	RESISTOR, CARB 10R/0,25J	PHI	
R14	240109	RESISTOR, CARB 10R/0,25J	PHI	
R15	240257	RESISTOR, CARB 180R/0,25J	PHI	3
R16	240516	RESISTOR, CARB 4K7/0,25J	PHI	
R17	240516	RESISTOR, CARB 4K7/0,25J	PHI	
R18	240222	RESISTOR, CARB 100R/0,25J	PHI	5
R19	240184	RESISTOR, CARB 47R/0,25J	PHI	1
R20	240400	RESISTOR, CARB 1K/0,25J	PHI	14
R21	240206	RESISTOR, CARB 56R/0,25J	PHI	
R22	240400	RESISTOR, CARB 1K/0,25J	PHI	
R23	240443	RESISTOR, CARB 2K/0,25J	PHI	2
R24	391980	RESISTOR, VAR 2K/0,5K	BOU	2
R25	240311	RESISTOR, CARB 330R/0,25J	PHI	3
R26	240567	RESISTOR, CARB 10K/0,25J	PHI	6
R27	240400	RESISTOR, CARB 1K/0,25J	PHI	
R28	240702	RESISTOR, CARB 56K/0,25J	PHI	6
R29	240702	RESISTOR, CARB 56K/0,25J	PHI	
R30	240702	RESISTOR, CARB 56K/0,25J	PHI	
R31	240567	RESISTOR, CARB 10K/0,25J	PHI	
R32	240702	RESISTOR, CARB 56K/0,25J	PHI	
R33	240702	RESISTOR, CARB 56K/0,25J	PHI	
R34	240745	RESISTOR, CARB 100K/0,25J	PHI	4
R35	366498	RESISTOR, FILM 12K1/0,125F	VIT	1
R36	450316	RESISTOR, FILM 47K5/0,125F	VIT	2
R37	450316	RESISTOR, FILM 47K5/0,125F	VIT	
R38	240567	RESISTOR, CARB 10K/0,25J	PHI	
R39	240605	RESISTOR, CARB 15K/0,25J	PHI	
R40	240745	RESISTOR, CARB 100K/0,25J	PHI	
R41	240745	RESISTOR, CARB 100K/0,25J	PHI	
R42	240400	RESISTOR, CARB 1K/0,25J	PHI	
R43	240680	RESISTOR, CARB 47K/0,25J	PHI	3
R44	324191	RESISTOR, CARB 7K5/0,25J	PHI	1
R45	240729	RESISTOR, CARB 75K/0,25J	PHI	2
R46	359165	RESISTOR, VAR 10K/0,5K	BOU	1
R47	240567	RESISTOR, CARB 10K/0,25J	PHI	
R48	240257	RESISTOR, CARB 180R/0,25J	PHI	
R49	240125	RESISTOR, CARB 22R/0,25J	PHI	2

Table 6.2 Replaceable Parts (cont'd)

		TITLE	PARTS LIST	
		IF/AF		
REF DES	DRA PART NO	NOMENCLATURE OR DESCRIPTION	MFR CODE	QTY
FIND NO				
R50	240729	RESISTOR, CARB 75K/0,25J	PHI	
R51	240311	RESISTOR, CARB 330R/0,25J	PHI	
R52	240311	RESISTOR, CARB 330R/0,25J	PHI	
R53	240427	RESISTOR, CARB 1K5/0,25J	PHI	
R54	240427	RESISTOR, CARB 1K5/0,25J	PHI	
R55	450324	RESISTOR, FILM 4K32/0,125F	VIT	1
R56	368539	RESISTOR, FILM 7K5/0,125F	VIT	1
R57	240109	RESISTOR, CARB 10R/0,25J	PHI	
R58	240494	RESISTOR, CARB 3K9/0,25J	PHI	1
R59	240621	RESISTOR, CARB 22K/0,25J	PHI	2
R60	240648	RESISTOR, CARB 27K/0,25J	PHI	
R61	240648	RESISTOR, CARB 27K/0,25J	PHI	
R62	357715	RESISTOR, VAR 1K/0,5K	BOU	1
R63	240680	RESISTOR, CARB 47K/0,25J	PHI	
R64	240346	RESISTOR, CARB 470R/0,25J	PHI	1
R65	240125	RESISTOR, CARB 22R/0,25J	PHI	
R66	240192	RESISTOR, CARB 51R/0,25J	PHI	2
R67	240400	RESISTOR, CARB 1K/0,25J	PHI	
R68	240222	RESISTOR, CARB 100R/0,25J	PHI	
R69	240443	RESISTOR, CARB 2K0/0,25J	PHI	
R70	240516	RESISTOR, CARB 4K7/0,25J	PHI	
R71	240699	RESISTOR, CARB 51K/0,25J	PHI	1
R72	240222	RESISTOR, CARB 100R/0,25J	PHI	
R73	240702	RESISTOR, CARB 56K/0,25J	PHI	
R74	240680	RESISTOR, CARB 47K/0,25J	PHI	
R75	240354	RESISTOR, CARB 510R/0,25J	PHI	1
R76	240362	RESISTOR, CARB 560R/0,25J	PHI	8
R77	240230	RESISTOR, CARB 120R/0,25J	PHI	
R78	240109	RESISTOR, CARB 10R/0,25J	PHI	
R79	240397	RESISTOR, CARB 820R/0,25J	PHI	5
R80	240168	RESISTOR, CARB 33R/0,25J	PHI	4
R81	240109	RESISTOR, CARB 10R/0,25J	PHI	
R82	240362	RESISTOR, CARB 560R/0,25J	PHI	
R83	240362	RESISTOR, CARB 560R/0,25J	PHI	
R84	240230	RESISTOR, CARB 120R/0,25J	PHI	
R85	240109	RESISTOR, CARB 10R/0,25J	PHI	
R86	240397	RESISTOR, CARB 820/0,25J	PHI	
R87	240168	RESISTOR, CARB 33R/0,25J	PHI	
R88	240109	RESISTOR, CARB 10R/0,25J	PHI	
R89	240362	RESISTOR, CARB 560R/0,25J	PHI	
R90	240362	RESISTOR, CARB 560R/0,25J	PHI	
R91	240230	RESISTOR, CARB 120R/0,25J	PHI	

Table 6.2 Replaceable Parts (cont'd)

		TITLE IF/AF	PARTS LIST	
REF DES	DRA PART NO	NOMENCLATURE OR DESCRIPTION	MFR CODE	QTY
FIND NO				
R92	240109	RESISTOR, CARB 10R/0,25J	PHI	
R93	240397	RESISTOR, CARB 820R/0,25J	PHI	
R94	240168	RESISTOR, CARB 33R/0,25J	PHI	
R95	240362	RESISTOR, CARB 560R/0,25J	PHI	
R96	240109	RESISTOR, CARB 10R/0,25J	PHI	
R97	240362	RESISTOR, CARB 560R/0,25J	PHI	
R98	240222	RESISTOR, CARB 100R/0,25J	PHI	
R99	240109	RESISTOR, CARB 10R/0,25J	PHI	
R100	240397	RESISTOR, CARB 820R/0,25J	PHI	
R101	328545	RESISTOR, CARB 220/0,25J	PHI	
R102	240168	RESISTOR, CARB 33R/0,25J	PHI	
R103	240362	RESISTOR, CARB 560R/0,25J	PHI	
R104	240613	RESISTOR, CARB 18K/0,25J	PHI	
R105	361542	RESISTOR, CARB 1K6/0,25J	PHI	1
R106	240427	RESISTOR, CARB 1K5/0,25J	PHI	
R107	240745	RESISTOR, CARB 100K/0,25J	PHI	
R108	240257	RESISTOR, CARB 180R/0,25J	PHI	
R109	376310	RESISTOR, VAR 200R/0,5K	BOU	1
R110	240397	RESISTOR, CARB 820R/0,25J	PHI	
R111	240451	RESISTOR, CARB 2K2/0,25J	PHI	
R112	328626	RESISTOR, CARB 220K/0,25J	PHI	
R113	240400	RESISTOR, CARB 1K/0,25J	PHI	
R114	240419	RESISTOR, CARB 1K2/0,25J	PHI	1
R115	240400	RESISTOR, CARB 1K/0,25J	PHI	
R116	240400	RESISTOR, CARB 1K/0,25J	PHI	
R117	240192	RESISTOR, CARB 51R/0,25J	PHI	
R118	240427	RESISTOR, CARB 1K5/0,25J	PHI	
R119	391980	RESISTOR, VAR 2K/0,5K	BOU	
R120	240486	RESISTOR, CARB 3K3/0,25J	PHI	2
R121	240486	RESISTOR, CARB 3K3/0,25J	PHI	
R122	240583	RESISTOR, CARB 12K/0,25J	PHI	1
R123	240400	RESISTOR, CARB 1K/0,25J	PHI	
R124	240222	RESISTOR, CARB 100R/0,25J	PHI	
R125	240567	RESISTOR, CARB 10K/0,25J	PHI	
R126	240567	RESISTOR, CARB 10K/0,25J	PHI	
R127	240737	RESISTOR, CARB 82K/0,25J	PHI	2
R128	240737	RESISTOR, CARB 82K/0,25J	PHI	
R129	433136	RESISTOR, FILM 6K19/0,125F	VIT	1
R130	444871	RESISTOR, FILM 27K4/0,125F	VIT	2
R131	444871	RESISTOR, FILM 27K4/0,125F	VIT	
R132	240516	RESISTOR, CARB 4K7/0,25J	PHI	

Table 6.2 Replaceable Parts (cont'd)

		TITLE	PARTS LIST	
		IF/AF		
REF DES	DRA PART NO	NOMENCLATURE OR DESCRIPTION	MFR CODE	QTY
FIND NO				
R133	240656	RESISTOR, CARB 33K/0,25J	PHI	1
R134	240621	RESISTOR, CARB 22K/0,25J	PHI	
R135	366889	RESISTOR, CARB 180K/0,25J	PHI	1
R136	240400	RESISTOR, CARB 1K/0,25J	PHI	
R137	240516	RESISTOR, CARB 4K7/0,25J	PHI	
R138	240400	RESISTOR, CARB 1K/0,25J	PHI	
R139	240400	RESISTOR, CARB 1K/0,25J	PHI	
R140	240400	RESISTOR, CARB 1K/0,25J	PHI	
R141	240400	RESISTOR, CARB 1K/0,25J	PHI	
R142	359408	RESISTOR, VAR 50K/0,5K	BOU	1
T1	451894	TRAFO	EMK	1
T2	451959	TRAFO	EMK	1
T3	451932	TRAFO	EMK	1
T4	362859	TRAFO, 600 OHM LINE		1
TP1-11	231304	TEST POINT		11
U1	450286	INTEGRATED CKT MC1349P	MOT	1
U2	361569	INTEGRATED CKT TBA120AS	SIE	1
U3	451878	INTEGRATED CKT MC14066BCP	MOT	1
U4	357707	INTEGRATED CKT MC1458P	MOT	3
U5	357707	INTEGRATED CKT MC1458P	MOT	
U6	393622	INTEGRATED CKT SN7407	TII	1
U7	373532	INTEGRATED CKT CA723CT	RCA	1
U8	450294	INTEGRATED CKT TL082CP	TII	1
U9	450308	INTEGRATED CKT CA3083	RCA	2
U10	450308	INTEGRATED CKT CA3083	RCA	
U11	361585	INTEGRATED CKT MC1496G	MOT	1
U12	357707	INTEGRATED CKT MC1458P	MOT	
U13	433683	INTEGRATED CKT SN74LS138	TII	1
U14	454028	INTEGRATED CKT SN74LS378	TII	1
U15	451169	INTEGRATED CKT SN74LS365	TII	1
U16	362131	INTEGRATED CKT SN7406	TII	1
U17	451185	INTEGRATED CKT SN74LS02	TII	1
VR1	228842	DIODE, SD, ZENER ZPD5,6	ITT	1

Table 6.2 Replaceable Parts (cont'd)

		TITLE IF/AF	PARTS LIST	
REF DES	DRA PART NO	NOMENCLATURE OR DESCRIPTION	MFR CODE	QTY
FIND NO				
VR2	228796	DIODE, SD, ZENER ZPD12	ITT	1
VR3	228869	DIODE, SD, ZENER ZPD7,5	ITT	1
VR4	228818	DIODE, SD, ZENER ZPD2,7	ITT	2
VR5	228818	DIODE, SD, ZENER ZPD2,7	ITT	
W1	458740	CABLE	EMK	1
W2	458759	CABLE ASSY	EMK	1
W3	458821	CABLE ASSY	EMK	1

Table 6.2 Replaceable Parts (cont'd)

		TITLE	PARTS LIST	
		MICROCOMPUTER		
REF DES	DRA PART NO	NOMENCLATURE OR DESCRIPTION	MFR CODE	QTY
FIND NO				
1	448491	PRINTED WIRING BOARD	EMK	1
2	448478	ELECTRICAL SCHEMATIC DIAGRAM		REF
3	448478	COMPONENT LOCATION DRAWING		REF
BT1	451495	BATTERY, LITH 3V/1AH	WRT	1
C1	451053	CAPACITOR, ELCT, AL 68U/6,3M	PHI	1
C2	451339	CAPACITOR, ELCT, AL 15U/10M	PHI	1
C3	357650	CAPACITOR, CER 22N/40A	CRL	1
C4	437395	CAPACITOR, CER 220P/100K	PHI	1
C5	450510	CAPACITOR, CER 100N/63S	SIE	25
C6	450510	CAPACITOR, CER 100N/63S	SIE	
C7	450510	CAPACITOR, CER 100N763S	SIE	
C8		NOT USED		
C9	357642	CAPACITOR, CER 10N/100S	PHI	3
C10	202991	CAPACITOR, PLST 220N/100K	PHI	2
C11	357642	CAPACITOR, CER 10N/100S	PHI	
C12	349070	CAPACITOR, PLST 680N/100K	PHI	1
C13	202991	CAPACITOR, PLST 220N/100K	PHI	
C14	454117	CAPACITOR, PLST 68N/250K	PHI	1
C15	357642	CAPACITOR, CER 10N/100S	PHI	
C16	450529	CAPACITOR, ELCT, AL 6U8/25M	PHI	3
C17	450529	CAPACITOR, ELCT, AL 6U8/25M	PHI	
C18	450529	CAPACITOR, ELCT, AL 6U8/25M	PHI	
C19	450510	CAPACITOR, CER 100N/63S	SIE	
C20	450510	CAPACITOR, CER 100N/63S	SIE	
C21	450510	CAPACITOR, CER 100N/63S	SIE	
C22	450510	CAPACITOR, CER 100N/63S	SIE	
C23	450510	CAPACITOR, CER 100N/63S	SIE	
C24	450510	CAPACITOR, CER 100N/63S	SIE	
C25	450510	CAPACITOR, CER 100N/63S	SIE	
C26	450510	CAPACITOR, CER 100N/63S	SIE	
C27	450510	CAPACITOR, CER 100N/63S	SIE	
C28	450510	CAPACITOR, CER 100N/63S	SIE	
C29	450510	CAPACITOR, CER 100N/63S	SIE	
C30	450510	CAPACITOR, CER 100N/63S	SIE	
C31	450510	CAPACITOR, CER 100N/63S	SIE	
C32	450510	CAPACITOR, CER 100N/63S	SIE	

Table 6.2 Replaceable Parts (cont'd)

		TITLE	PARTS LIST	
		MICROCOMPUTER		
REF DES	DRA PART NO	NOMENCLATURE OR DESCRIPTION	MFR CODE	QTY
FIND NO				
C33	450510	CAPACITOR, CER 100N/63S	SIE	
C34	450510	CAPACITOR, CER 100N/63S	SIE	
C35	450510	CAPACITOR, CER 100N/63S	SIE	
C36	450510	CAPACITOR, CER 100N/63S	SIE	
C37	450510	CAPACITOR, CER 100N/63S	SIE	
C38	450510	CAPACITOR, CER 100N/63S	SIE	
C39	450510	CAPACITOR, CER 100N/63S	SIE	
C40	450510	CAPACITOR, CER 100N/63S	SIE	
C41		NOT USED		
C42	357634	CAPACITOR, CER 2N2/100K	PHI	1
CR1	344966	DIODE, SI 1N4148	ITT	14
CR2		NOT USED		
CR3		NOT USED		
CR4	344966	DIODE, SI 1N4148	ITT	
CR5	344966	DIODE, SI 1N4148	ITT	
CR6	344966	DIODE, SI 1N4148	ITT	
CR7	344966	DIODE, SI 1N4148	ITT	
CR8	344966	DIODE, SI 1N4148	ITT	
CR9	344966	DIODE, SI 1N4148	ITT	
CR10	344966	DIODE, SI 1N4148	ITT	
CR11		NOT USED		
CR12	344966	DIODE, SI 1N4148	ITT	
CR13	344966	DIODE, SI 1N4148	ITT	
CR14	344966	DIODE, SI 1N4148	ITT	
CR15	450480	DIODE, LED 5082-4484	HPA	4
CR16	450480	DIODE, LED 5082-4484	HPA	
CR17	450480	DIODE, LED 5082-4484	HPA	
CR18	450480	DIODE, LED 5082-4484	HPA	
CR19	344966	DIODE, SI 1N4148	ITT	
CR20	344966	DIODE, SI 1N4148	ITT	
CR21	344966	DIODE, SI 1N4148	ITT	
CR22		NOT USED		
CR23	328324	DIODE, GE AAZ15	PHI	1
H1	458694	SCREW M 2,5 x 5 CHM		5
H2	230251	SLIDING LOCK POST D53018	CAN	1

Table 6.2 Replaceable Parts (cont'd)

		TITLE		PARTS LIST	
		MICROCOMPUTER			
REF DES	DRA PART NO	NOMENCLATURE OR DESCRIPTION	MFR CODE	QTY	
FIND NO					
H3	392707	DISC DISTANCE T018	JMY	8	
J1	368016	CONNECTOR DA-15S-1A0N	CAN	1	
L1	363944	COIL, CHOKE	PHI	3	
L2	363944	COIL, CHOKE	PHI		
L3	363944	COIL, CHOKE	PHI		
MP1	460230	REAR PLATE	EMK	1	
MP2	448095	PC RETAINER	EMK	1	
MP3	260819	THUMB SCREW 5T18978	EMK	2	
MP4	260843	RUBBER PAD		0,001	
Q1	392820	TRANSISTOR, NPN 2N2222A	MOT	5	
Q2	392820	TRANSISTOR, NPN 2N2222A	MOT		
Q3	392820	TRANSISTOR, NPN 2N2222A	MOT		
Q4		NOT USED			
Q5		NOT USED			
Q6	392839	TRANSISTOR, PNP 2N2907A		3	
Q7	393820	TRANSISTOR, NPN 2N2222A	MOT		
Q8	392820	TRANSISTOR, NPN 2N2222A	MOT		
Q9	392839	TRANSISTOR, PNP 2N2907A			
Q10		NOT USED			
Q11	392839	TRANSISTOR, PNP 2N2907A			
R1	240400	RESISTOR, CARB 1K0/0,25J	PHI	36	
R2	357693	RESISTOR, CARB 150K/0,25J	PHI	3	
R3	357693	RESISTOR, CARB 150K/0,25J	PHI		
R4	357693	RESISTOR, CARB 150K/0,25J	PHI		
R5	240400	RESISTOR, CARB 1K0/0,25J	PHI		
R6	372137	RESISTOR, CARB 20K/0,25J	PHI	6	
R7	240400	RESISTOR, CARB 1K0/0,25J	PHI		
R8	240699	RESISTOR, CARB 51K/0,25J	PHI	2	
R9	240699	RESISTOR, CARB 51K/0,25J	PHI		
R10	240400	RESISTOR, CARB 1K0/0,25J	PHI		
R11	240400	RESISTOR, CARB 1K0/0,25J	PHI		

Table 6.2 Replaceable Parts (cont'd)

		TITLE MICROCOMPUTER	PARTS LIST	
REF DES	DRA PART NO	NOMENCLATURE OR DESCRIPTION	MFR CODE	QTY
FIND NO				
R12	240400	RESISTOR, CARB 1K0/0,25J	PHI	
R13	240400	RESISTOR, CARB 1K0/0,25J	PHI	
R14	240400	RESISTOR, CARB 1K0/0,25J	PHI	
R15	240400	RESISTOR, CARB 1K0/0,25J	PHI	
R16	241458	RESISTOR, CARB 1K0/0,5J	PHI	6
R17	241458	RESISTOR, CARB 1K0/0,5J	PHI	
R18	240257	RESISTOR, CARB 180R/0,25J	PHI	3
R19	240400	RESISTOR, CARB 1K0/0,25J	PHI	
R20	240494	RESISTOR, CARB 3K9/0,25J	PHI	3
R21	240400	RESISTOR, CARB 1K0/0,25J	PHI	
R22	241458	RESISTOR, CARB 1K0/0,5J	PHI	
R23	241458	RESISTOR, CARB 1K0/0,5J	PHI	
R24	240257	RESISTOR, CARB 180R/0,25J	PHI	
R25	240400	RESISTOR, CARB 1K0/0,25J	PHI	
R26	240494	RESISTOR, CARB 3K9/0,25J	PHI	
R27	240400	RESISTOR, CARB 1K0/0,25J	PHI	
R28	241458	RESISTOR, CARB 1K0/0,5J	PHI	
R29	241458	RESISTOR, CARB 1K0/0,5J	PHI	
R30	240257	RESISTOR, CARB 180R/0,25J	PHI	
R31		NOT USED		
R32	240494	RESISTOR, CARB 3K9/0,25J	PHI	
R33	240400	RESISTOR, CARB 1K0/0,25J	PHI	
R34	240400	RESISTOR, CARB 1K0/0,25J	PHI	
R35	240400	RESISTOR, CARB 1K0/0,25J	PHI	
R36	240400	RESISTOR, CARB 1K0/0,25J	PHI	
R37		NOT USED		
R38		NOT USED		
R39	240400	RESISTOR, CARB 1K0/0,25J	PHI	
R40	240400	RESISTOR, CARB 1K0/0,25J	PHI	
R41	240400	RESISTOR, CARB 1K0/0,25J	PHI	
R42	240400	RESISTOR, CARB 1K0/0,25J	PHI	
R43	240249	RESISTOR, CARB 150R/0,25J	PHI	4
R44	240249	RESISTOR, CARB 150R/0,25J	PHI	
R45	240249	RESISTOR, CARB 150R/0,25J	PHI	
R46	240249	RESISTOR, CARB 150R/0,25J	PHI	
R47	240400	RESISTOR, CARB 1K0/0,25J	PHI	
R48	240400	RESISTOR, CARB 1K0/0,25J	PHI	
R49	240400	RESISTOR, CARB 1K0/0,25J	PHI	
R50		NOT USED		
R51	240400	RESISTOR, CARB 1K0/0,25J	PHI	
R52	240338	RESISTOR, CARB 390R/0,25J	PHI	3

Table 6.2 Replaceable Parts (cont'd)

		TITLE MICROCOMPUTER	PARTS LIST	
REF DES	DRA PART NO	NOMENCLATURE OR DESCRIPTION	MFR CODE	QTY
FIND NO				
R53	240400	RESISTOR, CARB 1K0/0,25J	PHI	
R54	240400	RESISTOR, CARB 1K0/0,25J	PHI	
R55	240400	RESISTOR, CARB 1K0/0,25J	PHI	
R56	240400	RESISTOR, CARB 1K0/0,25J	PHI	
R57	372137	RESISTOR, CARB 20K/0,25J	PHI	
R58	372137	RESISTOR, CARB 20K/0,25J	PHI	
R59	372137	RESISTOR, CARB 20K/0,25J	PHI	
R60	372137	RESISTOR, CARB 20K/0,25J	PHI	
R61		NOT USED		
R62	372137	RESISTOR, CARB 20K/0,25J	PHI	
R63	328634	RESISTOR, CARB 4M7/0,25J	PHI	1
R64	324205	RESISTOR, CARB 5K1/0,25J	PHI	2
R65	240567	RESISTOR, CARB 10K/0,25J	PHI	7
R66	324205	RESISTOR, CARB 5K1/0,25J	PHI	
R67	391093	RESISTOR, VAR 20K/0,5K	BOU	1
R68	240702	RESISTOR, CARB 56K/0,25J	PHI	7
R69	240869	RESISTOR, CARB 1M0/0,25J	PHI	1
R70	240443	RESISTOR, CARB 2K0/0,25J	PHI	2
R71	240400	RESISTOR, CARB 1K0/0,25J	PHI	
R72	240702	RESISTOR, CARB 56K/0,25J	PHI	
R73	240702	RESISTOR, CARB 56K/0,25J	PHI	
R74		NOT USED		
R75	240338	RESISTOR, CARB 390R/0,25J	PHI	
R76	240443	RESISTOR, CARB 2K0/0,25J	PHI	
R77	240567	RESISTOR, CARB 10K/0,25J	PHI	
R78	240745	RESISTOR, CARB 100K/0,25J	PHI	1
R79	240567	RESISTOR, CARB 10K/0,25J	PHI	
R80	240605	RESISTOR, CARB 15K/0,25J	PHI	1
R81	240567	RESISTOR, CARB 10K/0,25J	PHI	
R82	240400	RESISTOR, CARB 1K0/0,25J	PHI	
R83	240567	RESISTOR, CARB 10K/0,25J	PHI	
R84	240702	RESISTOR, CARB 56K/0,25J	PHI	
R85	240567	RESISTOR, CARB 10K/0,25J	PHI	
R86	240702	RESISTOR, CARB 56K/0,25J	PHI	
R87	240702	RESISTOR, CARB 56K/0,25J	PHI	
R88	240400	RESISTOR, CARB 1K0/0,25J	PHI	
R89	240400	RESISTOR, CARB 1K0/0,25J	PHI	
R90		NOT USED		
R91	362913	RESISTOR, CARB 15R/0,25J	PHI	1
R92		NOT USED		
R93	240702	RESISTOR, CARB 56K/0,25J	PHI	

Table 6.2 Replaceable Parts (cont'd)

		TITLE MICROCOMPUTER	PARTS LIST	
REF DES	DRA PART NO	NOMENCLATURE OR DESCRIPTION	MFR CODE	QTY
FIND NO				
R94		NOT USED		
R95	240338	RESISTOR, CARB 390R/0,25J	PHI	
R96	240567	RESISTOR, CARB 10K/0,25J	PHI	
R97	240400	RESISTOR, CARB 1K0/0,25J	PHI	
R98	240400	RESISTOR, CARB 1K0/0,25J	PHI	
R99	240400	RESISTOR, CARB 1K0/0,25J	PHI	
TP1-18	458562	TESTPOINTS, 18 PIN	AMP	1
TP19-21	458554	TESTPOINTS, 3 PIN	AMP	1
TP-22	457698	POST, WIREWRAPABLE	ELC	1
U1	433799	INTEGRATED CKT P8085A	ITL	1
U2	433527	INTEGRATED CKT SN74LS123	TII	1
U3	433535	INTEGRATED CKT SN74LS04	TII	3
U4	451541	INTEGRATED CKT SN74LS14	TII	1
U5	433535	INTEGRATED CKT SN74LS04	TII	
U6	362131	INTEGRATED CKT SN7406	TII	3
U7	434752	INTEGRATED CKT SN74LS08	TII	1
U8	451525	INTEGRATED CKT SN74LS00	TII	2
U9	451576	INTEGRATED CKT SN74LS161	TII	4
U10	433535	INTEGRATED CKT SN74LS04	TII	
U11	437107	INTEGRATED CKT SN74LS32	TII	2
U12	451614	INTEGRATED CKT SN74LS373	TII	1
U13	451169	INTEGRATED CKT SN74LS365	TII	1
U14	404608	INTEGRATED CKT SN74LS74	TII	2
U15	451525	INTEGRATED CKT SN74LS00	TII	
U16	451592	INTEGRATED CKT SN74LS240	TII	2
U17	451606	INTEGRATED CKT SN74LS245	TII	2
U18	393592	INTEGRATED CKT SN74LS11	TII	1
U19	433683	INTEGRATED CKT SN74LS138	TII	2
U20	437107	INTEGRATED CKT SN74LS32	TII	
U21	433683	INTEGRATED CKT SN74LS138	TII	
U22	433608	INTEGRATED CKT SN74LS21	TII	1
U23	433810	INTEGRATED CKT B2716	ITL	3
U24	433810	INTEGRATED CKT B2716	ITL	
U25	433810	INTEGRATED CKT B2716	ITL	
U26		NOT USED		
U27	451606	INTEGRATED CKT SN74LS245	TII	
U28	404608	INTEGRATED CKT SN74LS74	TII	

Table 6.2 Replaceable Parts (cont'd)

		TITLE	PARTS LIST	
		MICROCOMPUTER		
REF DES	DRA PART NO	NOMENCLATURE OR DESCRIPTION	MFR CODE	QTY
FIND NO				
U29	404551	INTEGRATED CKT SN7437	TII	3
U30	404551	INTEGRATED CKT SN7437	TII	
U31	404551	INTEGRATED CKT SN7437	TII	
U32	390909	INTEGRATED CKT MC1488L	MOT	1
U33	390917	INTEGRATED CKT MC1489AL	MOT	1
U34	433632	INTEGRATED CKT MCA255	MSO	3
U35	433632	INTEGRATED CKT MCA255	MSO	
U36	433632	INTEGRATED CKT MCA255	MSO	
U37	362131	INTEGRATED CKT SN7406	TII	
U38	451576	INTEGRATED CKT SN74LS161	TII	
U39	451576	INTEGRATED CKT SN74LS161	TII	
U40	451576	INTEGRATED CKT SN74LS161	TII	
U41	451592	INTEGRATED CKT SN74LS240	TII	
U42	451622	INTEGRATED CKT SN74LS259	TII	1
U43	451630	INTEGRATED CKT SN74LS379	TII	1
U44	451568	INTEGRATED CKT SN74LS145	TII	1
U45	454044	INTEGRATED CKT P2114A-5	ITL	2
U46	454044	INTEGRATED CKT P2114A-5	ITL	
U47	455466	INTEGRATED CKT UPD444/6514	NEC	1
U48	451517	INTEGRATED CKT SN74LS03	TII	1
U49	451843	INTEGRATED CKT MC14049UBCP	MOT	1
U50	451851	INTEGRATED CKT MC14013BCP	MOT	1
U51		NOT USED		
U52	451029	INTEGRATED CKT SN74LS377	TII	1
U53	451215	INTEGRATED CKT DAC-08EN	AMD	1
U54	450294	INTEGRATED CKT TL082CP	TII	2
U55	450294	INTEGRATED CKT TL082CP	TII	
U56	362131	INTEGRATED CKT SN7406	TII	
U57	451878	INTEGRATED CKT MC14066BCP	MOT	2
U58	451878	INTEGRATED CKT MC14066BCP	MOT	
U59	455474	INTEGRATED CKT LM3302N	NAT	1
VR1	363324	DIODE, SD, ZENER 5V1/0,1J	ITT	2
VR2	363324	DIODE, SD, ZENER 5V1/0,1J	ITT	
W1	225495	JUMPER, TINNED CU WIRE 0,7		0,001
XU1	451452	SOCKET 40 PIN C934002	TII	1

Table 6.2 Replaceable Parts (cont'd)

		TITLE MICROCOMPUTER	PARTS LIST		
REF DES	DRA PART NO	NOMENCLATURE OR DESCRIPTION	MFR CODE	QTY	
FIND NO					
XU23	364991	SOCKET 24 PIN C932402	TII	3	
XU24	364991	SOCKET 24 PIN C932402	TII		
XU25	364991	SOCKET 24 PIN C932402	TII		
XU32	362832	SOCKET 14 PIN C931402	TII	2	
XU33	362832	SOCKET 14 PIN C931402	TII		
XU45	451460	SOCKET 18 PIN C931802	TII	3	
XU46	451460	SOCKET 18 PIN C931802	TII		
XU47	451460	SOCKET 18 PIN C931802	TII		
Y1	433853	CRYSTAL UNIT, QUARTZ 6,144 MHZ	ITT	1	

Table 6.2 Replaceable Parts (cont'd)

		TITLE POWER SUPPLY	PARTS LIST		
REF DES	DRA PART NO	NOMENCLATURE OR DESCRIPTION	MFR CODE	QTY	
FIND NO					
1	448532	ELECTRICAL SCHEMATIC DIAGRAM		REF	
A10A1	448559	REGULATOR AND AF ASSY	EMK	1	
A10A2	448575	TRANSFORMER ASSY	EMK	1	
A10A3	458341	HEAT SINK ASSY	EMK	1	
A10A4	458368	TERMINAL ASSY	EMK	1	
H1	458694	SCREW M 2,5 x 5 CHM		4	
H2	276790	SCREW M 3 x 5 CHM		2	
H3	275638	SCREW M 4 x 8 CHM		4	
MP1	260819	THUMB SCREW 5T18978	EMK	2	
W1	458376	CABLE ASSY	EMK	1	
W2	458392	CABLE ASSY	EMK	1	

Table 6.2 Replaceable Parts (cont'd)

		TITLE	PARTS LIST	
		POWER SUPPLY REGULATOR AND AF ASSY		
REF DES	DRA PART NO	NOMENCLATURE OR DESCRIPTION	MFR CODE	QTY
FIND NO				
1	448540	PRINTED WIRING BOARD	EMK	1
2	448559	ELECTRICAL SCHEMATIC DIAGRAM		REF
3	448559	COMPONENT LOCATION DRAWING		REF
C1	454265	CAPACITOR, ELCT, AL 100U/25T	FRA	4
C2	202967	CAPACITOR, PLST 100N/100K	PHI	2
C3	450510	CAPACITOR, CER 100N/63S	SIE	12
C4	357634	CAPACITOR, CER 2N2/100K	PHI	3
C5	450510	CAPACITOR, CER 100N/63S	SIE	
C6	454273	CAPACITOR, ELCT, AL 220U/25T	EHF	2
C7	450510	CAPACITOR, CER 100N/63S	SIE	
C8	450510	CAPACITOR, CER 100N/63S	SIE	
C9	450529	CAPACITOR, ELCT, AL 6U8/25M	PHI	10
C10	450510	CAPACITOR, CER 100N/63S	SIE	
C11	357499	CAPACITOR, CER 27P/63G	PHI	1
C12	357634	CAPACITOR, CER 2N2/100K	PHI	
C13	450510	CAPACITOR, CER 100N/63S	SIE	
C14	454265	CAPACITOR, ELCT, AL 100U/25T	FRA	
C15	450510	CAPACITOR, CER 100N/63S	SIE	
C16	424625	CAPACITOR, PLST 330N/100K	PHI	1
C17	451053	CAPACITOR, ELCT, AL 68U/6,3M	PHI	2
C18	357634	CAPACITOR, 2N2/100K	PHI	
C19		NOT USED		
C20	454265	CAPACITOR, ELCT, AL 100U/25T	FRA	
C21	202967	CAPACITOR, PLST 100N/100K	PHI	
C22	448877	CAPACITOR, PLST 3N3/160F	SIE	1
C23	448907	CAPACITOR, PLST 10N/160F	SIE	1
C24	448915	CAPACITOR; PLST 12N/160F	SIE	1
C25	450529	CAPACITOR, ELCT, AL 6U8/25M	PHI	
C26	209503	CAPACITOR, PLST 470N/100K	PHI	1
C27	209554	CAPACITOR, PLST 10N/400K	PHI	1
C28	450529	CAPACITOR, ELCT, AL 6U8/25M	PHI	
C29	450529	CAPACITOR, ELCT, AL 6U8/25M	PHI	
C30	451053	CAPACITOR, ELCT, AL 68U/6,3M	PHI	
C31	450529	CAPACITOR, ELCT, AL 6U8/25M	PHI	
C32	450529	CAPACITOR, ELCT, AL 6U8/25M	PHI	
C33	454265	CAPACITOR, ELCT, AL 100U/25T	FRA	
C34	450510	CAPACITOR, CER 100N/63S	SIE	
C35	450529	CAPACITOR, ELCT, AL 6U8/25M	PHI	
C36	450529	CAPACITOR, ELCT, AL 6U8/25M	PHI	

Table 6.2 Replaceable Parts (cont'd)

		TITLE	PARTS LIST	
		POWER SUPPLY REGULATOR AND AF ASSY		
REF DES	DRA PART NO	NOMENCLATURE OR DESCRIPTION	MFR CODE	QTY
FIND NO				
C37	450510	CAPACITOR, CER 100N/63S	SIE	
C38	454281	CAPACITOR, ELCT, AL 1M0/25T	FRA	1
C39	344273	CAPACITOR, PLST 22N/250K	PHI	1
C40	454303	CAPACITOR, ELCT, AL 470U/16T	FRA	1
C41	454117	CAPACITOR, PLST 68N/250K	PHI	1
C42	454273	CAPACITOR, ELCT, AL 220U/25T	FRA	
C43	450510	CAPACITOR, CER 100N/63S	SIE	
C44	450529	CAPACITOR, ELCT, AL 6U8/25M	PHI	
C45	450510	CAPACITOR, CER 100N/63S	SIE	
C46	450510	CAPACITOR, CER 100N/63S	SIE	
C47	450529	CAPACITOR, ELCT, AL 6U8/25M	PHI	
C48	357642	CAPACITOR, CER 10N/100S	PHI	1
C49	385123	CAPACITOR, CER 4N7/100K	PHI	1
CR1	344966	DIODE, SI IN4148	ITT	9
CR2	344966	DIODE, SI IN4148	ITT	
CR3	344966	DIODE, SI IN4148	ITT	
CR4	344966	DIODE, SI IN4148	ITT	
CR5	344966	DIODE, SI IN4148	ITT	
CR6	344966	DIODE, SI IN4148	ITT	
CR7	344966	DIODE, SI IN4148	ITT	
CR8	344966	DIODE, SI IN4148	ITT	
CR9	344966	DIODE, SI IN4148	ITT	
H1	458694	SCREW M 2,5 x 5 CHM		5
H2	276790	SCREW M 3 x 5 CHM		5
H3	276804	SCREW M 3 x 8 CHM		1
H4	327514	NUT M 3		6
H5	362069	HEAT SINK		1
H6	391387	RUBBER PAD (SILICONE)		1
J1	454176	CONNECTOR, 6410/9A	MOX	1
J2	458481	CONNECTOR, 5046/11A	MOX	1
J3	446068	CONNECTOR, DE-9S-1A0N	CAN	1
J4	454168	CONNECTOR, 6410/2A	MOX	1
MP1	458384	SCREEN SHIELD	EMK	1

Table 6.2 Replaceable Parts (cont'd)

		TITLE	PARTS LIST	
		POWER SUPPLY REGULATOR AND AF ASSY		
REF DES	DRA PART NO	NOMENCLATURE OR DESCRIPTION	MFR CODE	QTY
FIND NO				
MP2	448095	PC RETAINER	EMK	1
MP3	455571	STAY NUT	EMK	2
Q2	273899	TRANSISTOR, NPN BC171	ITT	7
Q3	454206	THYRISTOR, 2N6402	MOT	3
Q4		NOT USED		
Q5	359157	TRANSISTOR, PNP BC251	ITT	4
Q6	454206	THYRISTOR, 2N6402	MOT	
Q7	359157	TRANSISTOR, PNP BC251	ITT	
Q8	359157	TRANSISTOR, PNP BC251	ITT	
Q9		NOT USED		
Q10	273899	TRANSISTOR, NPN BC171	ITT	
Q11	454206	THYRISTOR, 2N6402	MOT	
Q12	454605	TRANSISTOR, DUAL-J-FET, N, 2N3955	SLX	1
Q13	273899	TRANSISTOR, NPN BC171	ITT	
Q14	273899	TRANSISTOR, NPN BC171	ITT	
Q15	273899	TRANSISTOR, NPN BC171	ITT	
Q16	273899	TRANSISTOR, NPN BC171	ITT	
Q17	359157	TRANSISTOR, PNP BC251	ITT	
Q18	273899	TRANSISTOR, NPN BC171	ITT	
R1	240400	RESISTOR, CARB 1K0/0,25J	PHI	11
R2	240494	RESISTOR, CARB 3K9/0,25J	PHI	2
R3	240400	RESISTOR, CARB 1K0/0,25J	PHI	
R4	240524	RESISTOR, CARB 5K6/0,25J	PHI	6
R5	240524	RESISTOR, CARB 5K6/0,25J	PHI	
R6	240192	RESISTOR, CARB 51R/0,25J	PHI	2
R7	240400	RESISTOR, CARB 1K0/0,25J	PHI	
R8	240400	RESISTOR, CARB 1K0/0,25J	PHI	
R9	328545	RESISTOR, CARB 220R/0,25J	PHI	1
R10	454184	RESISTOR, WW R10/5K	DAE	3
R11	361534	RESISTOR, CARB 16K/0,25J	PHI	1
R12	324167	RESISTOR, CARB 300K/0,25J	PHI	1
R13	240605	RESISTOR, CARB 15K/0,25J	PHI	3
R14	369578	RESISTOR, FILM 5K11/0,125F	VIT	3
R15	369578	RESISTOR, FILM 5K11/0,125F	VIT	
R16	369578	RESISTOR, FILM 5K11/0,125F	VIT	
R17	240311	RESISTOR, CARB 330R/0,25J	PHI	3
R18	240583	RESISTOR, CARB 12K/0,25J	PHI	
R19	362239	RESISTOR, VAR 1K0/0,5K	BOU	2

Table 6.2 Replaceable Parts (cont'd)

		TITLE	PARTS LIST	
		POWER SUPPLY REGULATOR AND AF ASSY		
REF DES	DRA PART NO	NOMENCLATURE OR DESCRIPTION	MFR CODE	QTY
FIND NO				
R20	240427	RESISTOR, CARB 1K5/0,25J	PHI	2
R21	240400	RESISTOR, CARB 1K0/0,25J	PHI	
R22	240494	RESISTOR, CARB 3K9/0,25J	PHI	
R23	240400	RESISTOR, CARB 1K0/0,25J	PHI	
R24	240524	RESISTOR, CARB 5K6/0,25J	PHI	
R25	240524	RESISTOR, CARB 5K6/0,25J	PHI	
R26	240192	RESISTOR, CARB 51R/0,25J	PHI	
R27	240400	RESISTOR, CARB 1K0/0,25J	PHI	
R28	240400	RESISTOR, CARB 1K0/0,25J	PHI	
R29	359572	RESISTOR, CARB 110R/0,25J	PHI	1
R30	454192	RESISTOR, WW R22/5K	DAE	2
R31	454192	RESISTOR, WW R22/5K	DAE	
R32	240613	RESISTOR, CARB 18K/0,25J	PHI	1
R33	458686	RESISTOR, WW 4R7/3K	DAE	1
R34		NOT USED		
R35	372129	RESISTOR, FILM 178K/0,125F	VIT	1
R36	376434	RESISTOR, FILM 59K/0,125F	VIT	1
R37	240311	RESISTOR, CARB 330R/0,25J	PHI	
R38	240710	RESISTOR, CARB 68K/0,25J	PHI	1
R39	240540	RESISTOR, CARB 6K8/0,25J	PHI	1
R40	362239	RESISTOR, VAR 1K0/0,5K	BOU	
R41	240427	RESISTOR, CARB 1K5/0,25J	PHI	
R42	365963	RESISTOR, VAR 5K0/0,5K	BOU	1
R43		NOT USED		
R44	240400	RESISTOR, CARB 1K0/0,25J	PHI	
R45	240567	RESISTOR, CARB 10K/0,25J	PHI	10
R46	240621	RESISTOR, CARB 22K/0,25J	PHI	1
R47	240567	RESISTOR, CARB 10K/0,25J	PHI	
R48	240400	RESISTOR, CARB 1K0/0,25J	PHI	
R49	240400	RESISTOR, CARB 1K0/0,25J	PHI	
R50	240400	RESISTOR, CARB 1K0/0,25J	PHI	
R51	240524	RESISTOR, CARB 5K6/0,25J	PHI	
R52	240524	RESISTOR, CARB 5K6/0,25J	PHI	
R53	240222	RESISTOR, CARB 100R/0,25J	PHI	1
R54		NOT USED		
R55	240346	RESISTOR, CARB 470R/0,25J	PHI	2
R56	454184	RESISTOR, WW R10/5K	DAE	
R57	454184	RESISTOR, WW R10/5K	DAE	
R58	240567	RESISTOR, CARB 10K/0,25J	PHI	
R59	240567	RESISTOR, CARB 10K/0,25J	PHI	
R60	240567	RESISTOR, CARB 10K/0,25J	PHI	

Table 6.2 Replaceable Parts (cont'd)

		TITLE	PARTS LIST	
		POWER SUPPLY REGULATOR AND AF ASSY		
REF DES	DRA PART NO	NOMENCLATURE OR DESCRIPTION	MFR CODE	QTY
FIND NO				
R61	380393	RESISTOR, CARB 270K/0,25J	PHI	2
R62	240605	RESISTOR, CARB 15K/0,25J	PHI	
R63	240311	RESISTOR, CARB 330R/0,25J	PHI	
R64	240370	RESISTOR, CARB 620R/0,25J	PHI	2
R65	240338	RESISTOR, CARB 390R/0,25J	PHI	1
R66	349623	RESISTOR, FILM 10K/0,125F	VIT	4
R67	376566	RESISTOR, FILM 8K25/0,125F	VIT	1
R68	349623	RESISTOR, FILM 10K/0,125F	VIT	
R69	405604	RESISTOR, FILM 16K2/0,125F	VIT	1
R70	328626	RESISTOR, CARB 220K/0,25J	PHI	5
R71	328626	RESISTOR, CARB 220K/0,25J	PHI	
R72	328626	RESISTOR, CARB 220K/0,25J	PHI	
R73	328626	RESISTOR, CARB 220K/0,25J	PHI	
R74	240567	RESISTOR, CARB 10K/0,25J	PHI	
R75	240486	RESISTOR, CARB 3K3/0,25J	PHI	2
R76	359165	RESISTOR, VAR 10K/0,5K	BOU	1
R77	240486	RESISTOR, CARB 3K3/0,25J	PHI	
R78	349623	RESISTOR, FILM 10K/0,125F	VIT	
R79	349623	RESISTOR, FILM 10K/0,125F	VIT	
R80	454354	RESISTOR, FILM 20K5/0,125F	VIT	1
R81	240702	RESISTOR, CARB 56K/0,25J	PHI	1
R82	240370	RESISTOR, CARB 620R/0,25J	PHI	
R83	380393	RESISTOR, CARB 270K/0,25J	PHI	
R84	324175	RESISTOR, CARB 36K/0,25J	PHI	1
R85	450251	RESISTOR, NTC 15K	SIE	1
R86	240435	RESISTOR, CARB 1K8/0,25J	PHI	1
R87	328626	RESISTOR, CARB 220K/0,25J	PHI	
R88	240745	RESISTOR, CARB 100K/0,25J	PHI	1
R89	240850	RESISTOR, CARB 560K/0,25J	PHI	1
R90	240680	RESISTOR, CARB 47K/0,25J	PHI	1
R91	240451	RESISTOR, CARB 2K2/0,25J	PHI	4
R92	240397	RESISTOR, CARB 820R/0,25J	PHI	2
R93	240397	RESISTOR, CARB 820R/0,25J	PHI	
R94	240567	RESISTOR, CARB 10K/0,25J	PHI	
R95	240451	RESISTOR, CARB 2K2/0,25J	PHI	
R96	240419	RESISTOR, CARB 1K2/0,25J	PHI	3
R97	240567	RESISTOR, CARB 10K/0,25J	PHI	
R98	240451	RESISTOR, CARB 2K2/0,25J	PHI	
R99	240451	RESISTOR, CARB 2K2/0,25J	PHI	
R100	240567	RESISTOR, CARB 10K/0,25J	PHI	
R101	240419	RESISTOR, CARB 1K2/0,25J	PHI	

Table 6.2 Replaceable Parts (cont'd)

		TITLE	PARTS LIST	
		POWER SUPPLY REGULATOR AND AF ASSY		
REF DES	DRA PART NO	NOMENCLATURE OR DESCRIPTION	MFR CODE	QTY
FIND NO				
R102	240567	RESISTOR, CARB 10K/0,25J	PHI	
R103	240419	RESISTOR, CARB 1K2/0,25J	PHI	
R104	240346	RESISTOR, CARB 470R/0,25J	PHI	
R105	240176	RESISTOR, CARB 43R/0,25J	PHI	1
R106	240257	RESISTOR, CARB 180R/0,25J	PHI	1
R107	364029	RESISTOR, CARB 2R2/0,25J	PHI	1
R108	240958	RESISTOR, CARB 1R0/0,25J	PHI	1
R109	240559	RESISTOR, CARB 8K2/0,25J	PHI	1
TP1-12	231304	TEST POINT		12
U1	451282	INTEGRATED CKT LF356	NSC	1
U2	451266	INTEGRATED CKT LM301	NSC	1
U3	454370	INTEGRATED CKT UA79MG	FAI	1
U4	454222	INTEGRATED CKT LM324	NSC	2
U5	451231	INTEGRATED CKT LM723CN	NSC	1
U6	454222	INTEGRATED CKT LM324	NSC	
U7	454230	INTEGRATED CKT LM3054	NSC	1
U8	443964	INTEGRATED CKT TDA2002H	NSC	1
VR1	454389	DIODE, SD, ZENER ZPD16V	ITT	2
VR2	454389	DIODE, SD, ZENER ZPD16V	ITT	
VR3	228826	DIODE, SD, ZENER ZPD3V3	ITT	1
VR4	228842	DIODE, SD, ZENER ZPD5V6	ITT	2
VR5	228842	DIODE, SD, ZENER ZPD5V6	ITT	
VR6	228869	DIODE, SD, ZENER ZPD7V5	ITT	1

Table 6.2 Replaceable Parts (cont'd)

		TITLE	PARTS LIST	
		POWER SUPPLY TRANSFORMER ASSY		
REF DES	DRA PART NO	NOMENCLATURE OR DESCRIPTION	MFR CODE	QTY
FIND NO				
1	448567	PRINTED WIRING BOARD	EMK	1
2	448575	ELECTRICAL SCHEMATIC DIAGRAM		REF
3	448575	COMPONENT LOCATION DRAWING		REF
C1	385190	CAPACITOR, CER 4N7/5KVM	FRP	3
C2	385190	CAPACITOR, CER 4N7/5KVM	FRP	
C3	385190	CAPACITOR, CER 4N7/5KVM	FRP	
C4	458511	CAPACITOR, PLST 100N/630K	SIE	1
C5	209503	CAPACITOR, PLST 470N/100K	PHI	3
C6	209503	CAPACITOR, PLST 470N/100K	PHI	
C7	209503	CAPACITOR, PLST 470N/100K	PHI	
C8	454257	CAPACITOR, ELCT, AL 1M0/40T	FRA	2
C9	357626	CAPACITOR, CER 4N7/100S	PHI	1
C10	454613	CAPACITOR, ELCT, AL 10U/40T	FRA	1
C11	459437	CAPACITOR, ELCT, AL 330N/40M	PHI	1
C12	450510	CAPACITOR, CER 100N/63S	SIE	3
C13	202967	CAPACITOR, PLST 100N/100K	PHI	5
C14	202967	CAPACITOR, PLST 100N/100K	PHI	
C15	358959	CAPACITOR, CER 1N0/100K	PHI	
C16	358959	CAPACITOR, CER 1N0/100K	PHI	
C17	202967	CAPACITOR, PLST 100N/100K	PHI	
C18	202967	CAPACITOR, PLST 100N/100K	PHI	
C19	450510	CAPACITOR, CER 100N/63S	SIE	
C20	450529	CAPACITOR, ELCT, AL 6U8/25M	PHI	1
C21	454338	CAPACITOR, ELCT, AL 4M7/40T	FRA	1
C22	454257	CAPACITOR, ELCT, AL 1M0/40T	FRA	
C23	202967	CAPACITOR, PLST 100N/100K	PHI	
C24	454311	CAPACITOR, ELCT, AL 10M/25T	FRA	1
C25	450510	CAPACITOR, CER 100N/63S	SIE	
CR1	228141	DIODE, SI IN4007	PHI	6
CR2	344966	DIODE, SI IN4148	ITT	3
CR3	344966	DIODE, SI IN4148	ITT	
CR4	344966	DIODE, SI IN4148	ITT	
CR5	228141	DIODE, SI IN4007	PHI	
CR6	345865	DIODE, SI BYX71	PHI	1
CR7	373524	DIODE, SI MR501	MOT	2
CR8	373524	DIODE, SI MR501	MOT	
CR9	228141	DIODE, SI IN4007	PHI	

Table 6.2 Replaceable Parts (cont'd)

		TITLE POWER SUPPLY TRANSFORMER ASSY	PARTS LIST	
REF DES	DRA PART NO	NOMENCLATURE OR DESCRIPTION	MFR CODE	QTY
FIND NO				
CR10	228141	DIODE, SI IN4007	PHI	
CR11	228141	DIODE, SI IN4007	PHI	
CR12	228141	DIODE, SI IN4007	PHI	
CR13	458732	DIODE, SI 80SQ045	INR	2
CR14	458732	DIODE, SI 80SQ045	INR	
H1	458694	SCREW M 2,5 x 5 CHM		3
H2	327239	SCREW M 4 x 10 CHM		10
H3	446793	SCREW M 3 x 10 CHM		4
H4	458295	SCREW M 5 x 50 CHM		1
H5	276790	SCREW M 3 x 5 CHM		2
H6	336777	WASHER M 4		6
H7	321214	WASHER, LOCK M 4		6
H8	321613	WASHER, LOCK M 5		1
H9	321966	WASHER M 5		1
H10	327549	NUT M 5		1
H11	391387	RUBBER PAD (SILICONE)		4
H12	442399	TIE POINT		26
H13	458546	INSULATING BUSH	SGS	2
H14	450553	SCREW SELFTAPPING		3
J1	454176	CONNECTOR, 6410/9A	MOX	1
J2	454168	CONNECTOR, 6410/2A	MOX	1
K1	454095	REALY, DPDT, REL37	ERI	1
L1	454125	COIL, RF 25UH1,5A	FRP	2
L2	454125	COIL, RF 25UH1,5A	FRP	
L3	454133	COIL, RF 25UH14A	FRP	2
L4	454133	COIL, RF 25UH14A	FRP	
MP1	448095	PC RETAINER	EMK	1
MP2	458120	STAY NUT M 4 x 62	EMK	2
MP3	458139	STAY NUT M 4 x 64	EMK	2
MP4	200255	STAY NUT M 3 x 33	EMK	1
MP5	458414	SHIELD PLATE	EMK	1
MP6	458430	HEAT SINK	EMK	1
MP7	458570	RETAINER BRACKET	EMK	1

Table 6.2 Replaceable Parts (cont'd)

		TITLE	PARTS LIST	
		POWER SUPPLY TRANSFORMER ASSY		
REF DES	DRA PART NO	NOMENCLATURE OR DESCRIPTION	MFR CODE	QTY
FIND NO				
Q1	359157	TRANSISTOR, PNP BC251	ITT	4
Q2	359157	TRANSISTOR, PNP BC251	ITT	
Q3	359157	TRANSISTOR, PNP BC251	ITT	
Q4	359157	TRANSISTOR, PNP BC251	ITT	
Q5	454397	TRANSISTOR, NPN BDX53C	SGS	2
Q6	454397	TRANSISTOR, NPN BDX53C	SGS	
Q7	273899	TRANSISTOR, NPN BC171	ITT	2
Q8	273899	TRANSISTOR, NPN BC171	ITT	
R1	454109	RESISTOR, CARB 8K2/1J	PHI	1
R2	240605	RESISTOR, CARB 15K/0,25J	PHI	1
R3	240516	RESISTOR, CARB 4K7/0,25J	PHI	1
R4	240621	RESISTOR, CARB 22K/0,25J	PHI	1
R5	240540	RESISTOR, CARB 6K8/0,25J	PHI	1
R6	240710	RESISTOR, CARB 68K/0,25J	PHI	1
R7	324191	RESISTOR, CARB 7K5/0,25J	PHI	1
R8	240400	RESISTOR, CARB 1K0/0,25J	PHI	2
R9	240222	RESISTOR, CARB 100R/0,25J	PHI	1
R10	240435	RESISTOR, CARB 1K8/0,25J	PHI	2
R11	240435	RESISTOR, CARB 1K8/0,25J	PHI	
R12	240451	RESISTOR, CARB 2K2/0,25J	PHI	2
R13	454184	RESISTOR, WW R10/5J	DAE	2
R14	240451	RESISTOR, CARB 2K2/0,25J	PHI	
R15	454184	RESISTOR, WW R10/5J	DAE	
R16		NOT USED		
R17	240559	RESISTOR, CARB 8K2/0,25J	PHI	1
R18	368636	RESISTOR, VAR 2K0/0,5K	BOU	1
R19	240494	RESISTOR, CARB 3K9/0,25J	PHI	1
R20	240478	RESISTOR, CARB 2K7/0,25J	PHI	1
R21	240400	RESISTOR, CARB 1K0/0,25J	PHI	
R22	221520	RESISTOR, CARB 2K2/0,5J	PHI	1
T1	454249	TRANSFORMER	TRA	1
TB1	454214	TERMINAL BOARD	WMD	2
TP1-3	231304	TEST POINT		3
U1	433632	INTEGRATED CKT MCA 255	MOT	1

Table 6.2 Replaceable Parts (cont'd)

		TITLE	PARTS LIST		
		POWER SUPPLY TRANSFORMER ASSY			
REF DES	DRA PART NO	NOMENCLATURE OR DESCRIPTION	MFR CODE	QTY	
FIND NO					
U2	375349	INTEGRATED CKT LM 78L05	NSC	1	
U3	436895	INTEGRATED CKT LM 555CN	NSC	1	
U4	404764	INTEGRATED CKT SN74LS73	TII	1	
U5	454362	INTEGRATED CKT UA78MG	FAI	1	
VR1	454346	DIODE, SD, ZENER BZX87C75	PHI	4	
VR2	454346	DIODE, SD, ZENER BZX87C75	PHI		
VR3	361488	DIODE, SD, ZENER ZPD3V9	ITT	1	
VR4	363324	DIODE, SD, ZENER ZPD5V1	ITT	1	
VR5	454346	DIODE, SD, ZENER BZX87C75	PHI		
VR6	454346	DIODE, SD, ZENER BZX87C75	PHI		

Table 6.2 Replaceable Parts (cont'd)

		TITLE POWER SUPPLY HEAT SINK	PARTS LIST	
REF DES	DRA PART NO	NOMENCLATURE OR DESCRIPTION	MFR CODE	QTY
FIND NO				
1	448532	ELECTRICAL SCHEMATIC DIAGRAM		REF
H1	458546	INSULATING BUSH	SGS	3
H2	387363	MICA WASHER		3
H3	327220	SCREW M 4 x 8 CHM		4
H4	276790	SCREW M 3 x 5 CHM		6
H5	380105	WASHER		7
H6	436518	TUBULAR RIVET		7
H7	458465	CABLE CLAMP CV3		5
H8	458473	CABLE CLAMP CV6		5
H9	436186	PLASTIC TUBING	VTL	0,1M
MP1	458147	BACK-SPACE	EMK	1
MP2	458244	HEAT SINK	EMK	1
Q1	454400	TRANSISTOR, PNP BDX54A	SGS	2
Q2	454397	TRANSISTOR, NPN BDX53C	SGS	1
Q3	454400	TRANSISTOR, PNP BDX54A	SGS	
W1	458910	CABLE ASSY	EMK	1

Table 6.2 Replaceable Parts (cont'd)

		TITLE		PARTS LIST	
		POWER SUPPLY TERMINAL ASSY			
REF DES	DRA PART NO	NOMENCLATURE OR DESCRIPTION		MFR CODE	QTY
FIND NO					
1	448532	ELECTRICAL SCHEMATIC DIAGRAM			REF
F1	262706	FUSE, CARTRIDGE, SB 1A/		SIA	1
F2	394629	FUSE, CARTRIDGE, SB 6,3A/		SIA	1
H1	346225	SCREW M 3 x 20			2
H2	230251	SLIDING LOCK POST DS3018		CAN	1
H3	403377	SCREW, SELFTAPPING			2
J1	457736	CONNECTOR			1
MP1	460249	REAR PLATE		EMK	1
S1	248509	SWITCH, TOGGEL 4PDT		FJK	1
TB1	457744	TERMINAL BOARD		WMU	1
W1	458929	CABLE ASSY		EMK	1
XF1	358975	FUSEHOLDER		SHU	2
XF2	358975	FUSEHOLDER		SHU	

Table 6.2 Replaceable Parts (cont'd)

		TITLE	PARTS LIST	
		FRONT PANEL		
REF DES	DRA PART NO	NOMENCLATURE OR DESCRIPTION	MFR CODE	QTY
FIND NO				
1	448591	ELECTRICAL SCHEMATIC DIAGRAM		REF
A1	448591	FRONT PANEL CIRCUIT	EMK	1
H1	458694	SCREW M 2,5 x 5 CHM		4
H2	276790	SCREW M 3 x 5 CHM		8
H3	450545	SCREW M 5 x 12 FHM		4
H4	450553	SCREW SELF TAPPING		8
H5	321486	NUT M 10 x 1		2
H6	245674	WASHER, NYLON Ø 10	LKN	8
H7	403342	SCREW, POINTED M 3 x 6		2
H8	454443	KNOB WITH LINE Ø 10	ELM	1
H9	454435	KNOB CAP WITH LINE Ø 7,2	ELM	1
H10	454494	KNOB Ø 36	ELM	1
H11	454486	KNOB CAP Ø 30,3	ELM	1
H12	454478	KNOB WITH LINE Ø 14,5	ELM	3
H13	454451	KNOB CAP WITH LINE Ø 11	ELM	3
H14	230294	WASHER, LOCK		1
J1	454575	CONNECTOR, JACK SPSTNS		1
MP1	216674	HANDEL 111MM 4T19165	EMK	2
MP2	260827	THUMB SCREW 5T19164	EMK	4
MP3	268682	PILOT BUSHING 5T19090	EMK	4
MP4	460346	FRONT PLATE	EMK	1
MP5	457922	GUIDE SHEET	EMK	1
MP6	445827	ANGLE BRACKET	EMK	2
MP7	458015	PILOT BUSHING	EMK	1
MP8	459305	PILOT BUSHING	EMK	1
MP9	457728	CODE WHEEL	EMK	1
MP10	458023	FLY WHEEL	EMK	1
MP11	458007	SHAFT Ø 6,35	EMK	1
MP12	457957	GUARD PLATE	EMK	1
MP13	267015	WASHER, NYLON 5T20288	EMK	4

Table 6.2 Replaceable Parts (cont'd)

		TITLE FRONT PANEL	PARTS LIST		
REF DES	DRA PART NO	NOMENCLATURE OR DESCRIPTION		MFR CODE	QTY
FIND NO					
R1	454516	RESISTOR, VAR 10K/2K		BOU	1
R2	454508	RESISTOR, VAR 1K0/2K		BOU	2
R3	454508	RESISTOR, VAR 1K0/2K		BOU	
R4	459313	RESISTOR, VAR 4K7/0,1M		PHI	1
W1	458937	CABLE	ASSY	EMK	1
W2	458945	CABLE	ASSY	EMK	1
W3	458953	CABLE	ASSY	EMK	1

Table 6.2 Replaceable Parts (cont'd)

		TITLE FRONT PANEL CIRCUIT	PARTS LIST	
REF DES	DRA PART NO	NOMENCLATURE OR DESCRIPTION	MFR CODE	QTY
FIND NO				
1	448583	PRINTED WIRING BOARD	EMK	1
2	448591	ELECTRICAL SCHEMATIC DIAGRAM		REF
3	448591	COMPONENT LOCATION DRAWING		REF
A1	448613	DISPLAY ASSY	EMK	1
C1	450529	CAPACITOR, ELCT, AL 6U8/25M	PHI	5
C2	450510	CAPACITOR, CER 100N/63S	SIE	4
C3	450529	CAPACITOR, ELCT, AL 6U8/25M	PHI	
C4	393959	CAPACITOR, CER 100N/50M	VAD	4
C5	450529	CAPACITOR, ELCT, AL 6U8/25M	PHI	
C6	393959	CAPACITOR, CER 100N/50M	VAD	
C7	450510	CAPACITOR, CER 100N/63S	SIE	
C8	393959	CAPACITOR, CER 100N/50M	VAD	
C9	450510	CAPACITOR, CER 100N/63S	SIE	
C10	450510	CAPACITOR, CER 100N/63S	SIE	
C11	393959	CAPACITOR, CER 100N/50M	VAD	
C12	451053	CAPACITOR, ELCT, AL 68U/6,3M	PHI	1
C13	459410	CAPACITOR, ELCT, AL 10U/16M	PHI	1
C14	358959	CAPACITOR, CER 1N0/100K	PHI	1
C15	450529	CAPACITOR, ELCT, AL 6U8/25M	PHI	
C16	450529	CAPACITOR, ELCT, AL 6U8/25M	PHI	
C17	357650	CAPACITOR, CER 22N/40A	CRL	2
C18	357650	CAPACITOR, CER 22N/40A	CRL	
CR1	450480	DIODE, LED, RED 5082	HPA	15
CR2	450480	DIODE, LED, RED 5082	HPA	
CR3	450480	DIODE, LED, RED 5082	HPA	
CR4	450480	DIODE, LED, RED 5082	HPA	
CR5	450480	DIODE, LED, RED 5082	HPA	
CR6	450480	DIODE, LED, RED 5082	HPA	
CR7	450480	DIODE, LED, RED 5082	HPA	
CR8	450480	DIODE, LED, RED 5082	HPA	
CR9	450480	DIODE, LED, RED 5082	HPA	
CR10	450480	DIODE, LED, RED 5082	HPA	
CR11	450480	DIODE, LED, RED 5082	HPA	
CR12	450480	DIODE, LED, RED 5082	HPA	
CR13	450480	DIODE, LED, RED 5082	HPA	
CR14	450480	DIODE, LED, RED 5082	HPA	
CR15	450480	DIODE, LED, RED 5082	HPA	
CR16	344966	DIODE, SI 1N4148	ITT	2
CR17	344966	DIODE, SI 1N4148	ITT	

Table 6.2 Replaceable Parts (cont'd)

		TITLE	PARTS LIST		
		FRONT PANEL CIRCUIT			
REF DES	DRA PART NO	NOMENCLATURE OR DESCRIPTION	MFR CODE	QTY	
FIND NO					
DS 1	450472	LAMP, T-1 3/4 BI-PIN 5V/0,115A	OSH	2	
DS 2	450472	LAMP, T-1 3/4 BI-PIN 5V/0,115A	OSH		
H 1	458287	SCREW M 2,5 x 8 CHM		4	
H 2	276790	SCREW M 3 x 5 CHM		22	
H 3	276804	SCREW M 3 x 8 CHM		2	
H 4	380105	WASHER M 3		2	
H 5	321540	WASHER M 2,5		4	
H 6	327506	NUT M 3		2	
H 7	375209	NUT M 2,5		4	
H 8	454087	DISC, DISTANCE TO 18	PHI	12	
L 1	363944	COIL, CHOKE	PHI	3	
L 2	363944	COIL, CHOKE	PHI		
L 3	363944	COIL, CHOKE	PHI		
M 1	451401	METER 689G1	BET	1	
MP 1	458961	KNOB, BLACK, "SLOW"	EMK	1	
MP 2	458988	KNOB, BLACK, "INTER"	EMK	1	
MP 3	458996	KNOB, BLACK, "AM"	EMK	1	
MP 4	459003	KNOB, BLACK, "BFO"	EMK	1	
MP 5	459011	KNOB, WHITE, "9"	EMK	1	
MP 6	459038	KNOB, WHITE, "6"	EMK	1	
MP 7	459046	KNOB, WHITE, "3"	EMK	1	
MP 8	459054	KNOB, BLUE, "C"	EMK	1	
MP 9	459062	KNOB, BLACK, "ATT"	EMK	1	
MP 10	459070	KNOB, BLACK, "VNAR"	EMK	1	
MP 11	459089	KNOB, BLACK, "CW"	EMK	1	
MP 12	459097	KNOB, BLACK, "SCAN"	EMK	1	
MP 13	459100	KNOB, WHITE, "7"	EMK	1	
MP 14	459119	KNOB, WHITE, "4"	EMK	1	
MP 15	459127	KNOB, WHITE, "1"	EMK	1	
MP 16	459135	KNOB, WHITE, "0"	EMK	1	
MP 17	459143	KNOB, BLACK, "OFF"	EMK	1	
MP 18	459151	KNOB, BLACK, "WIDE"	EMK	1	
MP 19	459178	KNOB, BLACK, "SSB"	EMK	1	
MP 20	459186	KNOB, BLACK, "RCL"	EMK	1	

Table 6.2 Replaceable Parts (cont'd)

		TITLE	PARTS LIST		
		FRONT PANEL CIRCUIT			
REF DES	DRA PART NO	NOMENCLATURE OR DESCRIPTION	MFR CODE	QTY	
FIND NO					
MP21	459194	KNOB, BLACK, "STO"	EMK	1	
MP22	459208	KNOB, RED, "500"	EMK	1	
MP23	459216	KNOB, RED "2182"	EMK	1	
MP24	459224	KNOB, BLACK, "FAST"	EMK	1	
MP25	459232	KNOB, BLACK, "NARR"	EMK	1	
MP26	459240	KNOB, BLACK, "RTTY"	EMK	1	
MP27	459259	KNOB, BLACK, "TUNE"	EMK	1	
MP28	459267	KNOB, WHITE, "8"	EMK	1	
MP29	459275	KNOB, WHITE, "5"	EMK	1	
MP30	459283	KNOB, WHITE, "2"	EMK	1	
MP31	459291	KNOB, WHITE, "."	EMK	1	
MP32	448117	GUIDE SHEET 1	EMK	1	
MP33	448125	GUIDE SHEET 2	EMK	1	
MP34	453129	STAY NUT M 3 x 7	EMK	8	
MP35	377112	STAY NUT M3 X 6,8 4T22138	EMK	8	
MP36	453137	STAY NUT M3 x 12	EMK	8	
Q1	392839	TRANSISTOR, PNP 2N2907A		11	
Q2	392839	TRANSISTOR, PNP 2N2907A			
Q3	392839	TRANSISTOR, PNP 2N2907A			
Q4	392839	TRANSISTOR, PNP 2N2907A			
Q5	392839	TRANSISTOR, PNP 2N2907A			
Q6	392839	TRANSISTOR, PNP 2N2907A			
Q7	392839	TRANSISTOR, PNP 2N2907A			
Q8	392839	TRANSISTOR, PNP 2N2907A			
Q9	362980	TRANSISTOR, NPN MJE3055	MOT	1	
Q10	392839	TRANSISTOR, PNP 2N2907A			
Q11	369454	TRANSISTOR, NPN MPS-A13	MOT	3	
Q12	369454	TRANSISTOR, NPN MPS-A13	MOT		
Q13	369454	TRANSISTOR, NPN MPS-A13	MOT		
Q14	389730	TRANSISTOR, N-CHANNEL J-FET J300	SLX	1	
Q15	392820	TRANSISTOR, NPN 2N2222A	MOT	1	
Q16	392839	TRANSISTOR, PNP 2N2907A			
Q17	392839	TRANSISTOR, PNP 2N2907A			
R1	240400	RESISTOR, CARB 1K0/0,25J	PHI	5	
R2	457663	RESISTOR, NETWORK 8 x 1K5/0,25G	BOU	1	

Table 6.2 Replaceable Parts (cont'd)

		TITLE	PARTS LIST	
		FRONT PANEL CIRCUIT		
REF DES	DRA PART NO	NOMENCLATURE OR DESCRIPTION	MFR CODE	QTY
FIND NO				
R3	457647	RESISTOR, NETWORK 9 x 10K/0,2G	BOU	1
R4	241040	RESISTOR, CARB 15R/0,5J	PHI	8
R5	241040	RESISTOR, CARB 15R/0,5J	PHI	
R6	241040	RESISTOR, CARB 15R/0,5J	PHI	
R7	241040	RESISTOR, CARB 15R/0,5J	PHI	
R8	241040	RESISTOR, CARB 15R/0,5J	PHI	
R9	241040	RESISTOR, CARB 15R/0,5J	PHI	
R10	241040	RESISTOR, CARB 15R/0,5J	PHI	
R11	241040	RESISTOR, CARB 15R/0,5J	PHI	
R12	240419	RESISTOR, CARB 1K2/0,25J	PHI	1
R13	240605	RESISTOR, CARB 15K/0,25J	PHI	2
R14	324213	RESISTOR, CARB 3K0/0,25J	PHI	1
R15	240702	RESISTOR, CARB 56K/0,25J	PHI	1
R16	240516	RESISTOR, CARB 4K7/0,25J	PHI	3
R17	240516	RESISTOR, CARB 4K7/0,25J	PHI	
R18	457639	RESISTOR, NETWORK 7 x 4K7/0,2G	BOU	1
R19	240516	RESISTOR, CARB 4K7/0,25J	PHI	
R20	240486	RESISTOR, CARB 3K3/0,25J	PHI	3
R21	240486	RESISTOR, CARB 3K3/0,25J	PHI	
R22	240486	RESISTOR, CARB 3K3/0,25J	PHI	
R23	451355	RESISTOR, NETWORK 5 x 1K0/0,2G	BOU	1
R24	433470	RESISTOR, NETWORK 9 x 1K0/0,2G	BOU	1
R25	457671	RESISTOR, NETWORK 8 x 15K/0,25G	BOU	1
R26	349674	RESISTOR, FILM 15K/0,125F	VIT	1
R27	368539	RESISTOR, FILM 7K5/0,125F	VIT	8
R28	368539	RESISTOR, FILM 7K5/0,125F	VIT	
R29	368539	RESISTOR, FILM 7K5/0,125F	VIT	
R30	368539	RESISTOR, FILM 7K5/0,125F	VIT	
R31	368539	RESISTOR, FILM 7K5/0,125F	VIT	
R32	368539	RESISTOR, FILM 7K5/0,125F	VIT	
R33	368539	RESISTOR, FILM 7K5/0,125F	VIT	
R34	368539	RESISTOR, FILM 7K5/0,125F	VIT	
R35	240745	RESISTOR, CARB 100K/0,25J	PHI	1
R36	240605	RESISTOR, CARB 15K/0,25J	PHI	
R37	240400	RESISTOR, CARB 1K0/0,25J	PHI	
R38	240567	RESISTOR, CARB 10K/0,25J	PHI	3
R39	324205	RESISTOR, CARB 5K1/0,25J	PHI	1
R40		NOT USED		
R41		NOT USED		
R42	240400	RESISTOR, CARB 1K0/0,25J	PHI	
R43	240567	RESISTOR, CARB 10K/0,25J	PHI	

Table 6.2 Replaceable Parts (cont'd)

		TITLE FRONT PANEL CIRCUIT	PARTS LIST	
REF DES	DRA PART NO	NOMENCLATURE OR DESCRIPTION	MFR CODE	QTY
FIND NO				
R44	240567	RESISTOR, CARB 10K/0,25J	PHI	
R45	240400	RESISTOR, CARB 1K0/0,25J	PHI	
R46	240249	RESISTOR, CARB 150R/0,25J	PHI	2
R47	324221	RESISTOR, CARB 2K4/0,25J	PHI	2
R48	240621	RESISTOR, CARB 22K/0,25J	PHI	2
R49	240249	RESISTOR, CARB 150R/0,25J	PHI	
R50	324221	RESISTOR, CARB 2K4/0,25J	PHI	
R51	240621	RESISTOR, CARB 22K/0,25J	PHI	
R52	240400	RESISTOR, CARB 1K0/0,25J	PHI	
S1	450421	SWITCH SPST-NO	MAR	31
S2	450421	SWITCH SPST-NO	MAR	
S3	450421	SWITCH SPST-NO	MAR	
S4	450421	SWITCH SPST-NO	MAR	
S5	450421	SWITCH SPST-NO	MAR	
S6	450421	SWITCH SPST-NO	MAR	
S7	450421	SWITCH SPST-NO	MAR	
S8	450421	SWITCH SPST-NO	MAR	
S9	450421	SWITCH SPST-NO	MAR	
S10	450421	SWITCH SPST-NO	MAR	
S11	450421	SWITCH SPST-NO	MAR	
S12	450421	SWITCH SPST-NO	MAR	
S13	450421	SWITCH SPST-NO	MAR	
S14	450421	SWITCH SPST-NO	MAR	
S15	450421	SWITCH SPST-NO	MAR	
S16	450421	SWITCH SPST-NO	MAR	
S17	450421	SWITCH SPST-NO	MAR	
S18	450421	SWITCH SPST-NO	MAR	
S19	450421	SWITCH SPST-NO	MAR	
S20	450421	SWITCH SPST-NO	MAR	
S21	450421	SWITCH SPST-NO	MAR	
S22	450421	SWITCH SPST-NO	MAR	
S23	450421	SWITCH SPST-NO	MAR	
S24	450421	SWITCH SPST-NO	MAR	
S25	450421	SWITCH SPST-NO	MAR	
S26	450421	SWITCH SPST-NO	MAR	
S27	450421	SWITCH SPST-NO	MAR	
S28	450421	SWITCH SPST-NO	MAR	
S29	450421	SWITCH SPST-NO	MAR	
S30	450421	SWITCH SPST-NO	MAR	
S31	450421	SWITCH SPST-NO	MAR	

Table 6.2 Replaceable Parts (cont'd)

		TITLE FRONT PANEL CIRCUIT	PARTS LIST	
REF DES	DRA PART NO	NOMENCLATURE OR DESCRIPTION	MFR CODE	QTY
FIND NO				
U1	433683	INTEGRATED CKT SN74LS138	TII	1
U2	451185	INTEGRATED CKT SN74LS02	TII	1
U3	362131	INTEGRATED CKT SN7406	TII	3
U4	451541	INTEGRATED CKT SN74LS14	TII	1
U5	451614	INTEGRATED CKT SN74LS373	TII	1
U6	450294	INTEGRATED CKT TL082CP	TII	1
U7	451584	INTEGRATED CKT SN74LS164	TII	2
U8	451584	INTEGRATED CKT SN74LS164	TII	
U9	451592	INTEGRATED CKT SN74LS240	TII	1
U10	362131	INTEGRATED CKT SN7406	TII	
U11	365874	INTEGRATED CKT SN74LS74	TII	1
U12	362131	INTEGRATED CKT SN7406	TII	
U13	443255	INTEGRATED CKT OPB814	OPT	2
U14	443255	INTEGRATED CKT OPB814	OPT	
W1	459550	FLATCABLE ASSY	EMK	1
XA1P1	451479	CONNECTOR, 1-826044	AMP	2
XA1P2	451479	CONNECTOR, 1-826044	AMP	

Table 6.2 Replaceable Parts (cont'd)

		TITLE	PARTS LIST	
		FRONT PANEL CIRCUIT DISPLAY BOARD		
REF DES	DRA PART NO	NOMENCLATURE OR DESCRIPTION	MFR CODE	QTY
FIND NO				
1	448605	PRINTED WIRING BOARD	EMK	1
2	448613	ELECTRICAL SCHEMATIC DIAGRAM		REF
3	448613	COMPONENT LOCATION DRAWING		REF
P1	451487	CONNECTOR, 1-826063-0	AMP	2
P2	451487	CONNECTOR, 1-826063-0	AMP	
Q1	369454	TRANSISTOR, NPN MPS-A13	MOT	8
Q2	369454	TRANSISTOR, NPN MPS-A13	MOT	
Q3	369454	TRANSISTOR, NPN MPS-A13	MOT	
Q4	369454	TRANSISTOR, NPN MPS-A13	MOT	
Q5	369454	TRANSISTOR, NPN MPS-A13	MOT	
Q6	369454	TRANSISTOR, NPN MPS-A13	MOT	
Q7	369454	TRANSISTOR, NPN MPS-A13	MOT	
Q8	369454	TRANSISTOR, NPN MPS-A13	MOT	
R1	324191	RESISTOR, CARB 7K5/0,25J	PHI	1
R2	240141	RESISTOR, CARB 27R/0,25J	PHI	1
R3	457655	RESISTOR, NETWORK 4 x 3K3/0,2G	BEC	2
R4	457655	RESISTOR, NETWORK 4 x 3K3/0,2G	BEC	
U1	450499	INTEGRATED CKT 5082-7740	HPA	7
U2	450499	INTEGRATED CKT 5082-7740	HPA	
U3	450499	INTEGRATED CKT 5082-7740	HPA	
U4	450499	INTEGRATED CKT 5082-7740	HPA	
U5	450499	INTEGRATED CKT 5082-7740	HPA	
U6	450499	INTEGRATED CKT 5082-7740	HPA	
U7	450499	INTEGRATED CKT 5082-7740	HPA	
U8	450502	INTEGRATED CKT HLMP-2350	HPA	2
U9	450502	INTEGRATED CKT HLMP-2350	HPA	

Table 6.2 Replaceable Parts (cont'd)

		TITLE	PARTS LIST	
		CHASSIS		
REF DES	ORA PART NO	NOMENCLATURE OR DESCRIPTION	MFR CODE	QTY
FIND NO				
A1	448648	MOTHERBOARD ASSY	EMK	1
H1	387681	STAY NUT M 3 x 10 4T21920	EMK	10
H2	450588	SQUARE NUT M 3		16
H3	276723	SCREW M 3 x 8 FHM		12
H4	436909	ALLEN SCREW M3 x 8 STAINLESS		4
H5	450561	SELF TAPPING SCREW		40
H6	276790	SCREW M 3 x 5 CHM		20
H7	459526	SCREW M 4 x 6 CHM		12
H8	336777	WASHER M 4		12
MP1	448001	JUNCTION PLATE	EMK	1
MP2	445886	PC PROFILE 1M	EMK	5
MP3	445894	PC PROFILE 1M DRILL	EMK	2
MP4	445908	PC PROFILE 1,5 M	EMK	3
MP5	445940	SIDEPROFILE	EMK	2
MP6	458600	RAIL SECTION	EMK	2
MP7	458619	SPLICE-PIECE	EMK	6

Table 6.2 Replaceable Parts (cont'd)

		TITLE MOTHERBOARD	PARTS LIST	
REF DES	DRA PART NO	NOMENCLATURE OR DESCRIPTION	MFR CODE	QTY
FIND NO				
1	448621	PRINTED WIRING BOARD	EMK	1
2	448648	ELECTRICAL SCHEMATIC DIAGRAM		REF
3	448648	COMPONENT LOCATION DRAWING		REF
C1	393959	CAPACITOR, CER 100N/50M	VAD	2
C2	393959	CAPACITOR, CER 100N/50M	VAD	
H1	454419	CONNECTOR, CODE PIN	CAN	18
H2	459429	CONTACT STRIP	ISP	0,25M
R6	240451	RESISTOR, CARB 2K2/0,25J	PHI	1
R7	240400	RESISTOR, CARB 1K0/0,25J	PHI	5
R8	240400	RESISTOR, CARB 1K0/0,25J	PHI	
R9	240400	RESISTOR, CARB 1K0/0,25J	PHI	
R10	451371	RESISTOR, NETWORK 9 x 2K2/0,2G	BOU	1
R11	451363	RESISTOR, NETWORK 5 x 2K2/0,2G	BOU	1
R12	240400	RESISTOR, CARB 1K0/0,25J	PHI	
R13	240400	RESISTOR, CARB 1K0/0,25J	PHI	
R14	240354	RESISTOR, CARB 510R/0,25J	PHI	1
U1	451606	INTEGRATED CKT SN74LS245	TII	2
U2	451606	INTEGRATED CKT SN74LS245	TII	
U3	404551	INTEGRATED CKT SN7437	TII	1
XA1P1	451509	CONNECTOR, G11D036P2ABBL	CAN	9
XA2P1	451509	CONNECTOR, G11D036P2ABBL	CAN	
XA3P1	451509	CONNECTOR, G11D036P2ABBL	CAN	
XA4P1	451509	CONNECTOR, G11D036P2ABBL	CAN	
XA6P1	451509	CONNECTOR, G11D036P2ABBL	CAN	
XA7P1	451509	CONNECTOR, G11D036P2ABBL	CAN	
XA8P1	451509	CONNECTOR, G11D036P2ABBL	CAN	
XA9P1	451509	CONNECTOR, G11D036P2ABBL	CAN	
XA10P1	451509	CONNECTOR, G11D036P2ABBL	CAN	

Table 6.3 List of Manufacturers Codes

Mfr. code	Manufacturer Name	Country
AMD	Advanced Micro Devices	U S A
AMP	AMP Inc. Harrisburg	U S A
BEC	Beckman Instruments Ltd.	Skotland
BET	Bertram	Germany
BOU	Bourns Inc.	U S A
CAN	ITT Cannon Electric	U S A
CAT	Cathodeon Crystals Ltd.	England
CHE	Cherry Microschalter GmbH	Germany
CRL	Draloric Div. 1,2,3	Germany
DAE	Dale Electronic, Nebraska	U S A
ELC	Elco Corporation, California	U S A
ELM	Elma Electronic AG	Schweiz
EMK	Dansk Radio AS	Denmark
ENI	Erni & Co., Elektro-Industri	Schweiz
ETI	Elec-Trol Inc., California	U S A
FAI	Fairchild Semiconductor Components	U S A
FHS	Fischer Elektronik	Germany
FJK	Fujisoku Electric Co.	Japan
FRA	Frako GmbH	Germany
FRP	Ferroperm A/S	Denmark
HEE	Helag Electronic GmbH	Germany
HPA	Hewlett Packard Components	U S A
INR	International Rectifier	U S A
ISP	Instrument Specialties Co.	U S A
ITT	ITT	U S A
JMY	Jermyn Industries	England
KCK	KCK Co.Ltd.	Japan
KRI	Kristall-Verarbeitung GmbH	Germany
LKN	LK NES	Denmark
MAR	J.J.Marquardt	Germany
MOT	Motorola Semiconductor Products Div. Inc.	U S A
MSO	Monsanto Company	U S A
NEC	NEC	Japan
NSC	National Semiconductor, California	U S A
OPT	Optron, Carrollton	U S A
OSH	Oshino Electric Lamp Works Ltd.	Japan
PHI	Philips	Netherlands
PRA	Prahn-Ferroperm	Denmark
RCA	RCA	U S A
SEF	Seifert Electronic	Germany
SGS	SGS-Ates	Italy
SIA	Siba Sicherungen-Bau GmbH	Germany
SIE	Siemens	Germany
SLX	Siliconix Ltd.	England
SUH	Suhner AG	Schweiz
TII	Texas Instrument	U S A
TRA	Transduktor A/S	Denmark
VAD	Varadyne Industries Inc., California	U S A
VAR	Vari-L Company Inc., Colorado	U S A
VIT	VTM Electronics A/S	Denmark
VTL	Vactite Ltd.	England
VGT	Vogt & Co.	Germany
WMU	Weidmüller KG, C.A.	Germany
WRT	Warta Batterie AG	Germany

SECTION 7
MANUAL CHANGES

This section contains information for correcting manual errors and for adapting the manual to equipment containing improvements made after the printing of the manual or to equipment containing options.

Manual changes per august 1982.

ASSY A1.

R120 and R148 changed from 3K3 to 2K0 on pages 6-12, 6-13 and 8-23.

ASSY A2.

The designations J1 and J2 are interchanged on the circuit diagrams 8-29 and 8-33.

ASSY A3A1.

VR1 replaced with a resistor R75 2K0 and R74 is changed from 1K0 to 240R on pages 6-29 and 8-37.

ASSY A3A5.

Q7 changed from SD306 to 3N211 on pages 6-35 and 8-39.

The value of R47 is factory adjusted.

ASSY A4.

A decoupling capacitor C80 1u is placed from K5 pin 9 to ground. Pages 6-41 and 8-45.

R32 is replaced with a choke coil L56 82u on pages 6-45, 6-44 and 8-47.
Choke coils L51, L52, L53, L54 and L55 10u are added on pages 6-44 and 8-45.

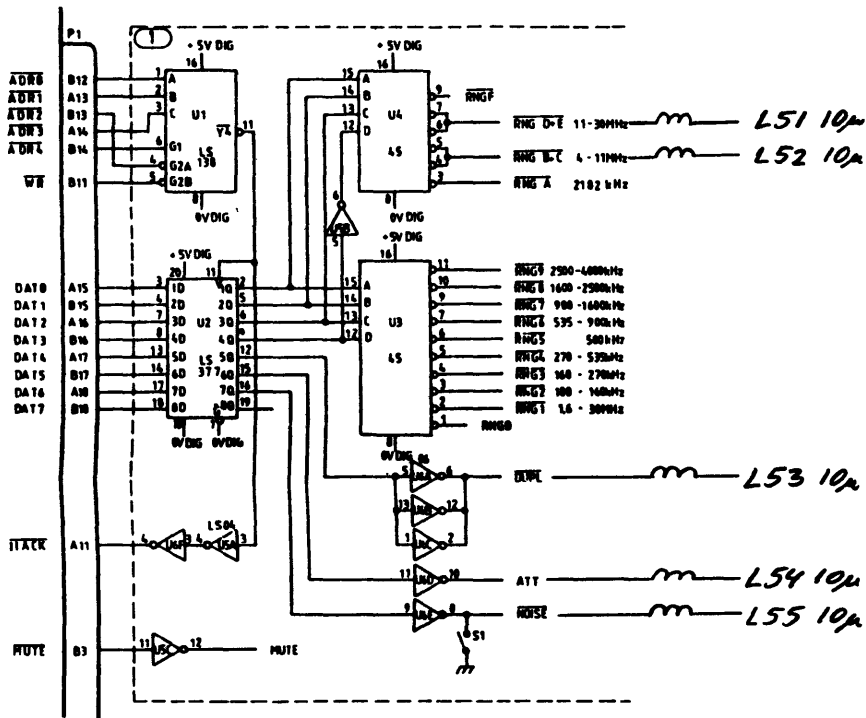

Designation of L29 4u7 is changed to L28 4u7 on page 8-47.

C25 220p is deleted. Pages 6-39 and 8-47.

C49 changed from 1n0 to 470p. Pages 6-40 and 8-47.

R37 and R38 changed from 270K to 2M2. Pages 6-43 and 8-47.

ASSY A7.

Designation of C17 placed next to C15 is changed to C16. Component drawing on pages 8-51-55.

R59 changed from 22K to 15K and R60 changed from 27K to 12K. Pages 6-52 and 8-51.

Drawing error. The connection from U5 pin 2 to U5 pin 3 should be removed.
Page 8-55.

Pin numbers on J4 are changed. 1,2,3,4 changes to 2,3,4,1. Page 8-55.

ASSY A8.

Circuit change. Timer (1mS) is moved from U40 pin 15 to U40 pin 11.

Page 8-65.

ASSY A10A1.

C18 changed from 2n2 to 4n7. Pages 6-65 and 8-75.

R86 1K8 is factory adjusted. Pages 6-69 and 8-77.

Circuit changed around U3. R20 changed from 1K5 to 2K4. R19 1K deleted.

R110 factory adjusted value is added. Pages 6-67, 6-68, 6-70 and 8-75.

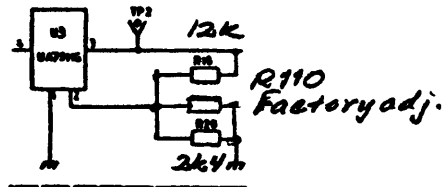

Circuit changed around U5. R40 changed from 1K potentiometer to 1K5 fixed. R41 1K5 deleted.

R42 changed from 5K potentiometer to 3K9 fixed.

R111 2K2, R112 factory adjusted value, R113 1K2, R114 2K7 and R115 factory adjusted value are added.

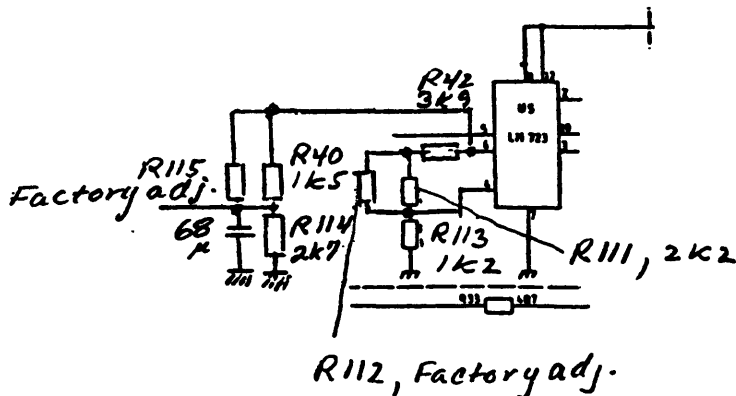

ASSY A10A1 continued.

Circuit change. R116 22K is added. It is connected from base to emitter of Q8 BC251.

Pages 6-70 and 8-75.

Circuit change around U6. One end of R70 220K and R72 220K have been moved. R117 56K and R118 56K are added. Pages 6-70 and 8-77.

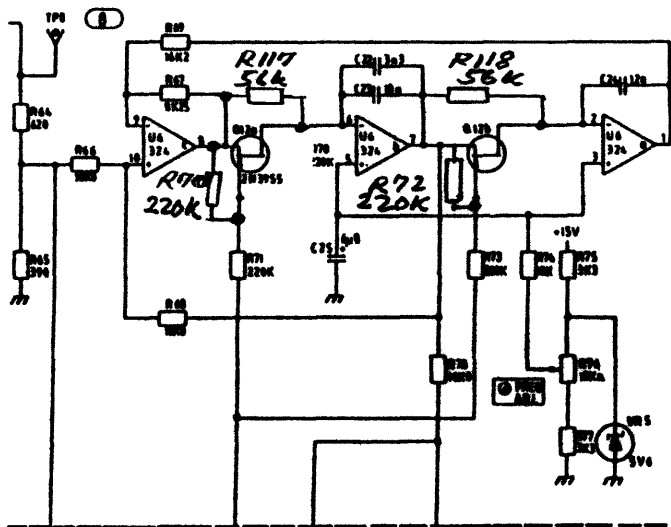

ASSY A10.

Mechanical change. A10A1-J2, A10A1-J4 and A10A2-J2 has been changed from tinplated to goldplated types. Pages 8-75 and 8-79.

Mechanical change. A10A1-J1, A10A1-J1, A10A2-J1 and A10-W1 are deleted and replaced by A10-W1 flatcable-assembly. Pages 6-64, 6-66 and 6-72.

ASSY A10A3.

Drawing error. Collector/base connections interchanged on Q1, Q2 and Q3. Page 8-73.

ASSY A10A2.

VR7 1V5 zener diode added in series with R2 15K. Pages 6-74 and 8-79.

Circuit changed around U5. R17 changed from 8K2 to 6K8. R18 2K potentiometer changed to fixed resistor with factory adjusted value. Pages 6-73 and 8-79.

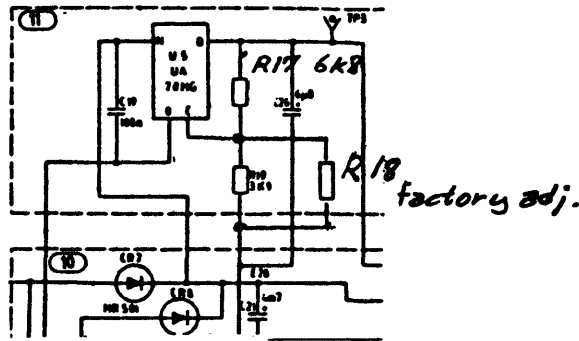

Circuit change. The anode of C8 1m0 is moved from the cathode of CR6 to the anode of CR6. Page 8-79.

CR15 80SQ45 is added. The anode is connected to the negative end of C8 1m0 and the cathode is connected to the positive end of C8. Pages 6-72 and 8-79.

ASSY A11A1.

C14 1n0 changed to 10n. Pages 6-79 and 8-89. R37 1K0 changed to 390R.
Pages 6-82 and 8-89.

R13 15K changed to 18K. R14 3K0 changed to 2K4. Pages 6-82 and 8-83.

R47 2K4 and R50 2K4 are changed to factory adjusted value. Pages 6-83
and 8-89.

SECTION 8 SERVICE

8.1 Introduction

This section provides information for servicing the Oceanic receiver.

8.2 Theory of Operation

The overall theory of operation is explained beginning with paragraph 8.11. Each paragraph explains with the aid of block diagrams the operation of functional assemblies.

Detailed theory of operation is located opposite the schematics.

8.3 Troubleshooting

WARNING

Read the Safety Summary at the front of this manual before troubleshooting the receiver.

By the use of front-panel controls, note as many symptoms of the malfunction as possible. From these symptoms it can usually be determined which assembly is malfunctioning. The Self-Test Program and the Fault Analysis Table (table 8.2b) can be used as a guide.

When a problem has been isolated to a particular assembly or circuit, the faulty component(s) may be located using the detailed theory of operation shown on the page opposing the appropriate schematic.

8.4 Self-Test Program

Receiver Test Program.

The built-in test program goes through the following sequence:

- a) Assembly test. The μ P addresses the individual interface circuits to see whether they are present. If an assy does not acknowledge the call, the μ P displays e.g. "A3 FAIL" and then continues the test.
- b) Synthesizer lock test. The synthesizer is set up near the boundaries of the VCO ranges, which are equivalent to the receiving frequencies 0, 6⁻, 6⁺, 12⁻, 12⁺, 20⁻, 20⁺ and 29.99999 MHz. If the synthesizer does not lock up within 100 msec., the display shows "OSC 1 Err".
- c) Gain test. The synthesizer is set to 75 MHz and the feed-through in the signal path is measured at the AGC to be above a reasonable level.

Also the presence of audio output from the detector is examined. The test is repeated with different BFO frequencies and crystal filters. If the BFO does not lock up, the display shows "OSC 3 Err" followed by "no Audio".

If the BFO level is low or an error is present in the AGC or the detector, the display shows "no Audio".

If the gain in the signal path is low, or the synthesizer level or 73.6 MHz oscillator level is low, the display shows "GAin Lo".

E.g. a fault in one of the crystal filters or in an interconnecting cable will result in "GAin Lo". An AGC fault can also cause this readout.

- d) Sensitivity test. The receiver is set to 4 MHz, AM, Wide and noise is generated in the preselector. The AGC voltage is measured to be above a reasonable level. If the sensitivity is more than ca. 20dB worse than spec., the display shows "SEnS LO".

Faults in the preselector itself may not be discovered in this test.

- e) Display test. All LED's are lit.
- f) The software version number is displayed.
- g) Key test. Pressing any key but "C" results in the hexadecimal value of the key being shown. See table 8.2a.

8.5 Preventive Maintenance

Painted surfaces can be cleaned with a commercial, spray-type window cleaner or with a mild soap and water solution.

CAUTION

Avoid the use of chemical cleaning agents that might damage the plastics used in this receiver.

The pushbutton switches in this receiver were designed for long, trouble-free service. If one of these switches should become defective, replacement rather than repair is recommended.

8.6 Front Panel Assembly Removal

To remove the front panel assembly proceed as follows:

- a. remove the preselector knob on the front panel by lifting off the knob cap and unscrewing the knob.
- b. remove the four screws holding the front panel. The four screws are located on the exterior of the receiver side panels.
- c. carefully withdraw the front panel assembly and disconnect the ribbon cable connector from the motherboard.

- d. to reinstall the front panel assembly, reverse removal procedure, carefully aligning the preselector shaft through the front panel bushing.

8.7 PC-Board Assembly Removal.

To remove a pc-board assembly proceed as follows:

- a. Disconnect the regulation transistor cable from A10J2 and remove the power supply heat sink panel by removing the four screws holding the panel. The four screws are located on the exterior of the receiver side panels.
- b. Disconnect all cables running to the relevant assembly.
- c. In the case of removing the Preselector A4, remove the preselector knob on the front panel by lifting off the knob cap and unscrewing the knob.
- d. Remove the six (eight) screws positioned at the edge of the relevant assembly rear panel and withdraw the assembly. If the assembly is stuck in the chassis frame, it may be necessary to carefully release the assembly by keying a screwdriver in between the rear panel and the main frames.
- e. To reinstall the assembly, reverse removal procedure, carefully aligning the preselector shaft through the front panel bushing (only valid for A4).

Due to the use of self tapping screws holding the assembly rear panel to the chassis frame, carefully reinsert the screws in the threads when reversing step d above.

8.8 Servicing PC-Boards

All the pc-boards have plated-through component holes. This allows components to be removed or replaced by unsoldering or soldering from either side of the board. When removing large components, rotate the soldering iron tip from lead to lead while applying pressure to the part to lift it from the board.

8.9 MOS Handling Precautions

All MOS devices are subject to damage from static charge buildup. The generation of static charges is not a problem, but the accumulation of static charges is. In general, any device not connected directly to ground can accumulate static charges. Electrical discharge can occur to ground or to any object or person having a lower potential. Therefore, handling precautions are recommended for all personnel coming into contact with MOS devices.

8-25. When handling or testing MOS devices, observe the following precautions:

a. Ground test equipment and tools used

in testing or handling MOS devices.

- b. Do not apply power to board assembly while MOS device is being installed. This permits accumulated static charges on MOS device to be safely removed before power is applied.
- c. When not in use, short all MOS leads. This prevents voltage differences from occurring on leads.

WARNING

When accomplishing step d, never expose personnel directly to hard electrical ground. For safety reasons, resistance of at least 100 Kohms should be placed between using personnel and hard electrical ground.

- d. Do not handle MOS devices by their leads. Before handling any MOS device, personnel should touch electrical ground to discharge accumulated static charges.
- e. Avoid use of plastics, rubber, and silk in MOS areas. Do not use any material susceptible to static charge accumulation.
- f. Handle circuit boards and modules containing MOS devices in the same manner as individual MOS devices. Regardless of configuration, whenever leads of MOS devices are exposed, damage due to static-charge buildup can occur.

- g. Use conductive, grounded table tops in MOS work area.
- h. Humidity in work area should be maintained above 50%. Static charge generation increases exponentially as relative humidity decreases.

8.10 Logic Devices

This receiver uses three different families of logic circuits: MOS, TTL and ECL. Most of the logic devices used in this receiver are TTL and are represented by unmarked logic symbols on the schematics. Logic elements, not of the TTL Logic family, are so indicated on the schematics. Table 8.1 below lists typical voltage levels associated with each family used in this receiver.

Table 8.1 Typical logic levels

Logic Family	High Level	Low Level
TTL	3 - 5V	0.2V
ECL	4.3 to 4.7V	3.4 to 3.7V
MOS	5 - 15V	0V

8.11 Basic Principles of Operation

The following paragraphs contain functional descriptions keyed to the block diagrams. The block diagrams are drawn for function and do not show circuit details. Schematic and detailed descriptions of each circuit are located on subsequent service sheets.

8.12 Overall Operation

The overall functional block diagram of the receiver is shown in Figure 8.1

The antenna signal is connected to the Preselector Assembly A4, which serves two objectives, matching the antenna impedance and rejecting unwanted signals. Duplex filters, designed for the maritime duplex bands, may be incorporated in the Preselector Assembly (Option 003). A built-in noise generator ensures preselector tuning in absence of input signals.

From A4 the filtered signal is routed to the Front-end Assembly A3, where the signal is up-converted to the first intermediate frequency at 75 MHz and crystal filtered to approx. 12 kHz bandwidth. Following the first AGC-amplifier, the signal is then down-converted to the second intermediate frequency at 1.4 MHz and crystal filtered to the final information bandwidth.

The 1.4 MHz signal is then routed to the IF/AF assembly A7, where final amplification with subsequent SSB/CW or AM demodulation is performed. An AGC-leveled IF output is accessible at the rear panel of the assembly.

The Power Supply Assembly A10, incorporates AF notch filter and output amplifier for driving the operators headphone or loudspeaker. The Power Supply Assembly accepts both 110/220 Vac and 24 Vdc supply through the use of a floating inverter circuit. During mains drop-out the battery supply is automatically selected.

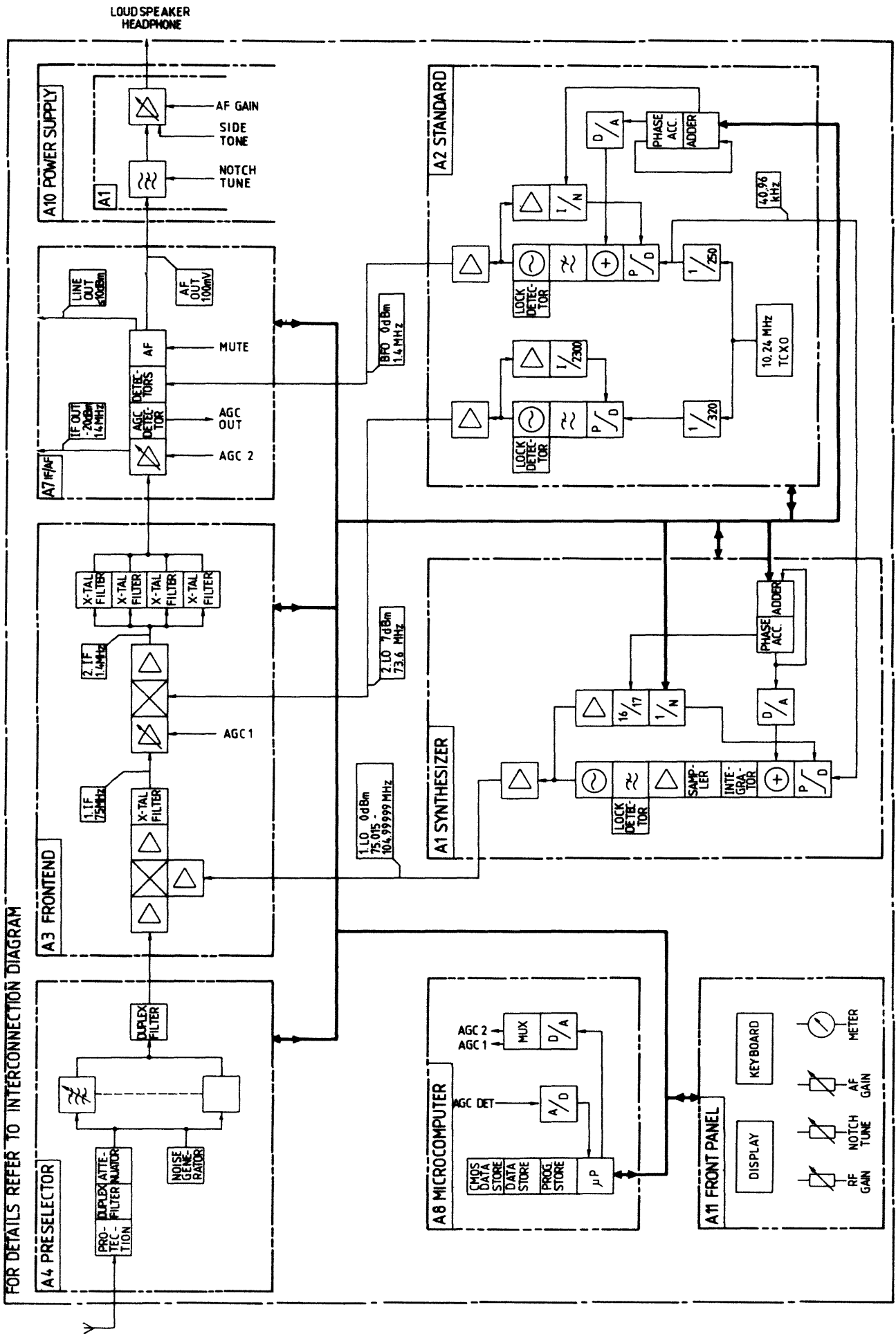
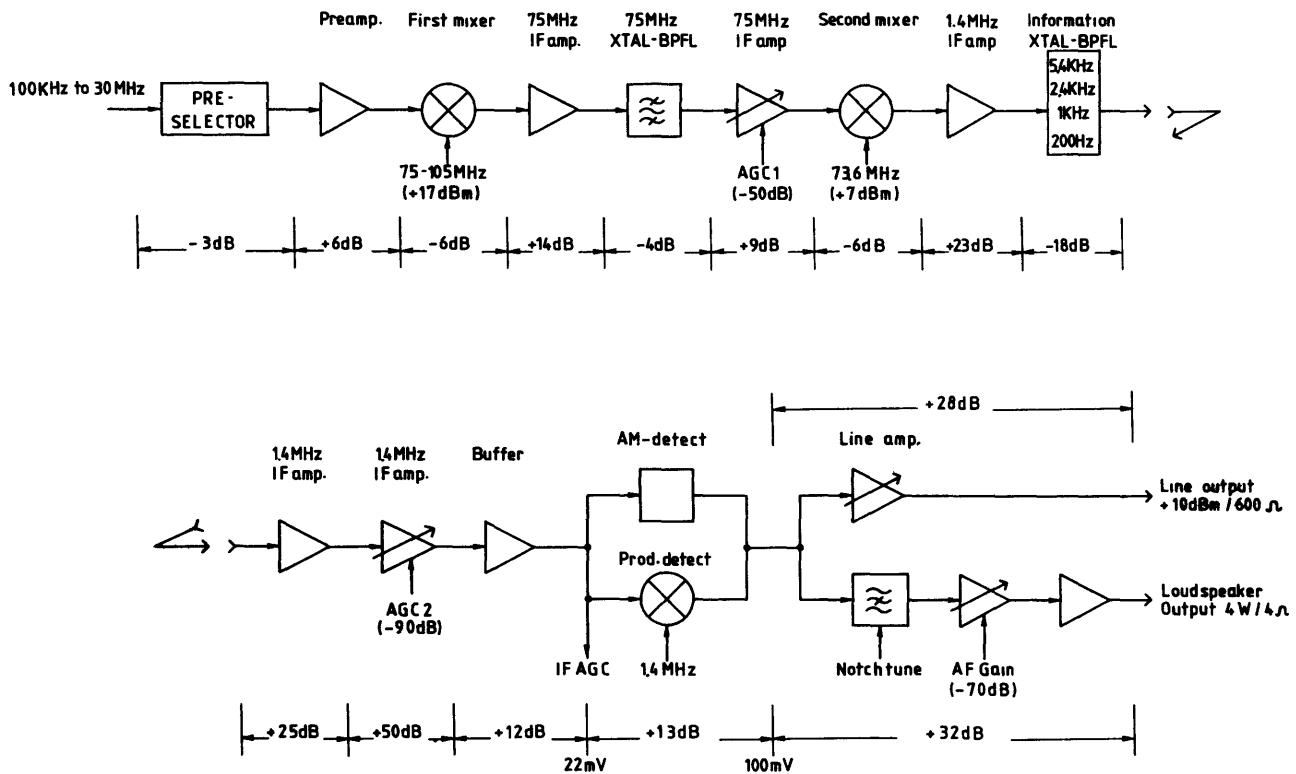

Figure 8.1 Overall Functional Block Diagram 8-5



Note: Voltage Gain shown are for reference only

Figure 8.2 Signal path block diagram

The Synthesizer Assembly A1, generates the first local oscillator signal tunable from 75 MHz to 105 MHz in 10 Hz increments.

The Standard Assembly A2, generates the second local oscillator signal at 73.6 MHz, the Synthesizer Assembly reference signal, and the synthesized beat frequency oscillator signal tunable from 1.393 MHz to 1.407 MHz in 10 Hz increments.

The Microcomputer Assembly A8, performs the overall control of the receiver. Typical tasks handled by the assembly:

- Control of the individual assemblies
- Keyboard and steptune reading
- Display refreshing
- AGC/GC through multiplexed D/A-A/D conversion
- Programmable memory set-ups
- Scanning
- Channel stepping
- Squelch control
- Remote control
- Diagnostic routines

Communication between the Microcomputer Assembly and the remaining assemblies is conducted over an internal bus running on the mother pc-board and the front panel ribbon cable.

8.13 Synthesizer Assembly A1

The functional block diagram of the Synthesizer Assembly is shown in Figure 8.3

1831 and 2563. This output is compared with the 40,96 kHz reference clock in a sample and hold phase detector. The ratio P is used as input to a digital loop adding the fractional ratio to an

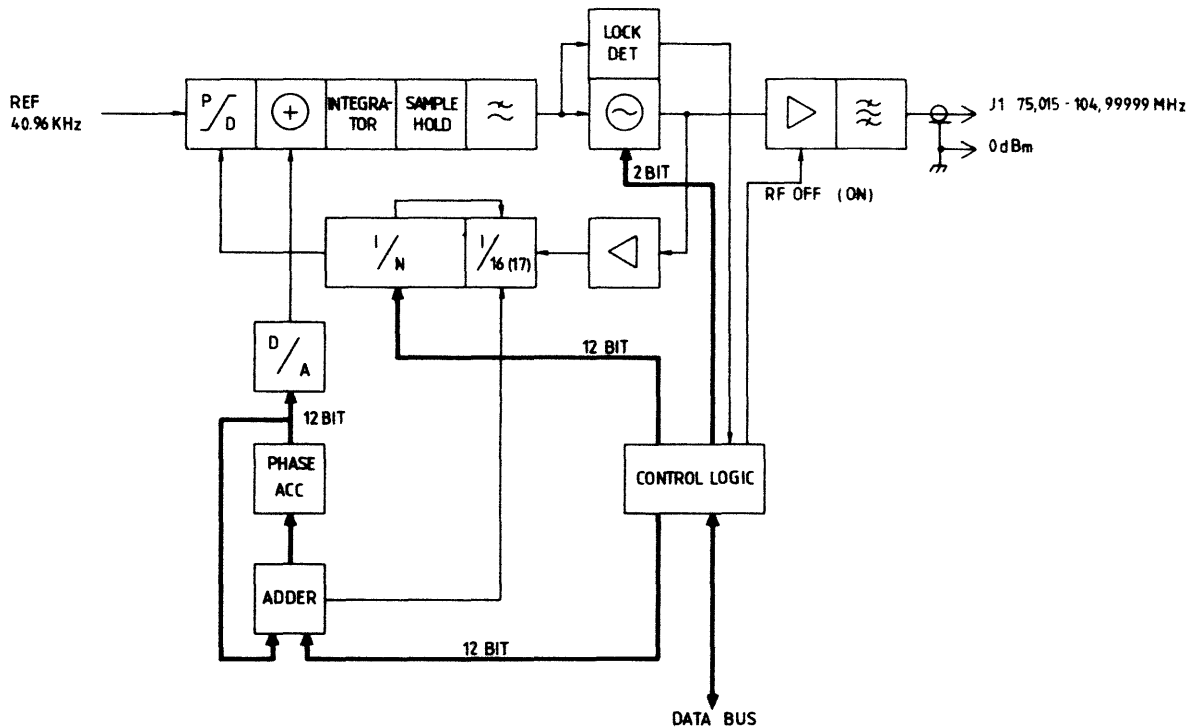

Figure 8.3 Synthesizer Assembly

The assembly generates the 75.015-104.99999 MHz 1. Lo signal for the Front-end Assembly A3. The synthesizer uses a fractional N techniques, where the loop output frequency is equal to the number $N.P$ times the reference frequency, where N and P are positive integers. The output signal from the loop oscillator is routed through a 16 (17) divider, controlled either by the N counter, or by the fractional phase accumulator. The N divider combined with the 16 (17) divider changes division ratio between

accumulated residual fraction. Every time the accumulated residual fraction overflows, the 16 (17) counter is commanded to delay the 17 to 16 count transition by one reference clock period, which corresponds to deleting one pulse from the signal feeding the N divider.

To compensate for pulse delete sidebands on the synthesizer output signal, the residual fraction is converted to an analog signal and added to the error signal from the phase

detector. The composite error signal is filtered before entering the control input of the voltage controlled oscillator.

8.14 Standard Assembly A2

The functional block diagram of the Standard Assembly is shown in Figure 8.4

The output signal from the temperature compensated crystal oscillator is applied to two divider chains. One generating 32kHz reference clock for the 73.6 MHz loop, and one generating 40.96 KHz reference clock for the 1.4 MHz loop and the Synthesizer Assembly.

The 73.6 MHz oscillator is formed by a voltage controlled crystal oscill-

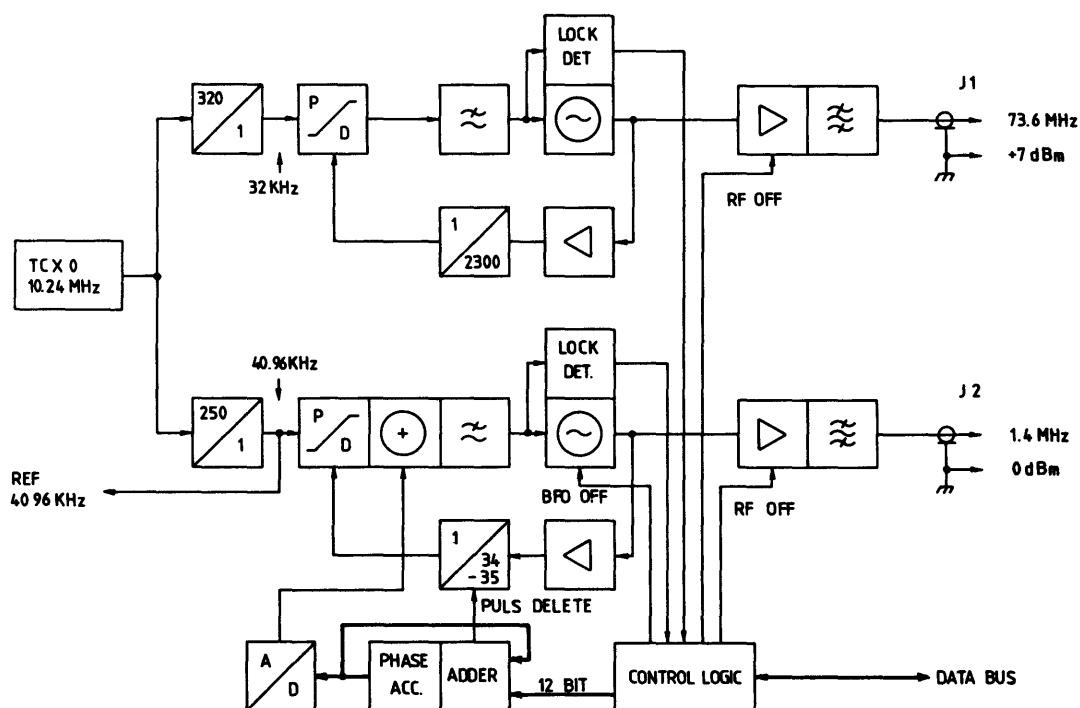

Figure 8.4 Standard Assembly

The assembly holds three basic functions:

- 10.24 MHz stable master oscillator
- 73.6 MHz synthesized second LO
- 1.4 MHz synthesized BFO

tor ensuring low side-band noise. The loop has a 10 Hz bandwidth compensating for frequency drift.

The 1.4 MHz synthesizer is tunable in 10 Hz increments. The loop reference

frequency is 40.96 kHz and the corresponding loop band-width approx. 800 Hz. The loop uses a fractional N technique, where the loop output frequency is equal to the number of N.P. times the reference frequency, where N and P are positive integers. Due to the limited tuning requirements for the loop, the N number is fixed 34. The programmed number P is used as input to a digital loop adding the fractional ratio to an accumulated residual fraction. Every time the accumulated residual fraction overflows, the N divider is commanded to divide by 35, deleting one vco clock pulse. The average vco frequency will in this way be realised with 40.96 kHz divided by P. To compensate for pulse delete sidebands on the 1.4 MHz

signal, the residual fraction is converted to an analog signal and added to the error signal from the phase detector. The composite error signal is filtered before entering the control input of the voltage controlled oscillator.

During AM mode reception the 1.4 MHz BFO signal is muted.

8.15 Front-end Assembly A3

The functional block diagram of the Front-end Assembly is shown in Figure 8.5

The Front-end Assembly contains the RF preamplifier, the first and second

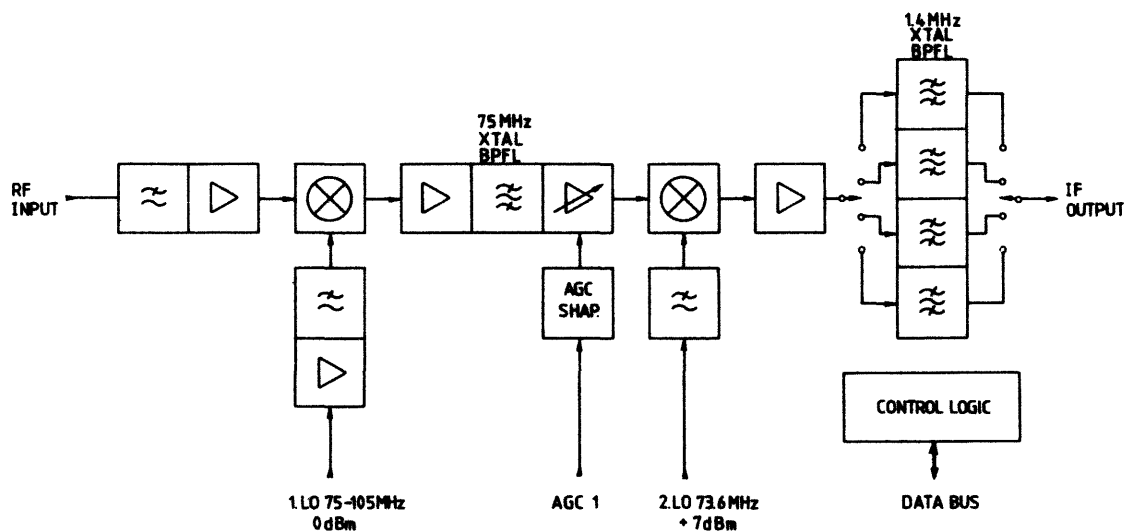

Figure 8.5 Front-end Assembly

mixer with associated injection amplifiers, the 75 MHz IF amplifier, and the information crystal filters.

The 15 kHz to 30 MHz input signal is first preamplified approx. 6 dB before entering a high LO injection (+17 dBm) up-converting mixer. The high LO signal is derived from a broad-band amplifier placed close to the mixer.

The up-converted 75 MHz first IF signal is then amplified 14 dB in a parallel FET circuit and crystal filtered to a bandwidth of approx. 12 kHz. The AGC1-amplifier following the crystal filter further amplifies the signal 9 dB with an 50 dB delayed AGC. Delayed AGC is brought into operation when the received input

level reaches about 40 dB above 1 microvolt.

The second mixer down converts the signal to the second IF frequency of 1.4 MHz. The down-converted signal is amplified 23 dB and impedance matched to the four information crystal filters. These filters determine the overall receiver selectivity. The filters are switched by means of series-diodes.

8.16 Preselector Assembly A4

The functional block diagram of the Preselector Assembly is shown in Figure 8.6

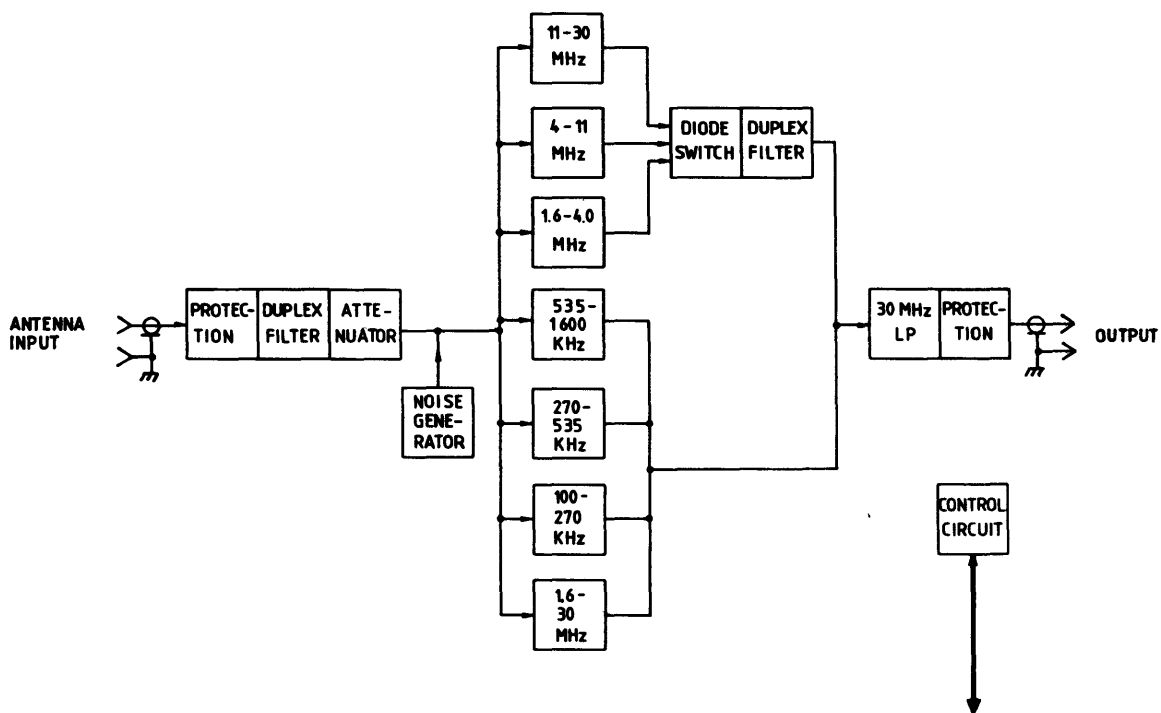

Figure 8.6 Preselector Assembly

The primary function of the Pre-selector assembly is to provide selectivity ahead of the front-end preamplifier and to match short antennas to the impedance of the amplifier.

The frequency range 15 kHz to 4 MHz is covered by four filters. Each filter consists of a tunable part to match the antenna impedance and a fixed part to attenuate out-of-band signals.

The frequency range 4 MHz to 30 MHz is covered by two tunable filters each consisting of two inductively coupled parallel resonant circuits.

The duplex filters, when supplied, attenuate signals in the TX channels of the maritime duplex bands.

A noise generator, activated by pushing the preselector knob, ensures pre-selector tuning in the absence of input signals.

To reduce interference from adjacent and/or high power transmitters, a 20 dB switchable pad is incorporated to attenuate incoming signals.

An input overload circuit protects the receiver against extreme antenna signals. The overload circuit can sustain 30 V_{rms}/continuous and 50V_{rms}/15 minutes burn-out.

An output protection circuit prevents spike products from the switch circuits reaching the Front-end Assembly.

When the receiver is operated in the scan-mode the preselector filters are bypassed.

8.17 IF/AF Assembly A7

The functional block diagram of the IF/AF Assembly is shown in Figure 8.7

The IF/AF Assembly contains the 1.4 MHz second IF amplifier, demodulators, AGC detector and AF line output circuit.

The 1.4 MHz signal is first amplified approx. 25 dB and impedance matched before entering the AGC2-amplifier. The AGC2-amplifier further amplifies the signal 50 dB with an AGC-range of 90 dB. The amplified signal is separated into four paths, one for the synchronous AM-demodulator, one for the balanced SSB/CW demodulator, one for the AGC-detector, and one for the buffered IF output driving auxiliary equipment.

The AGC-detection is performed by the use of four emitter coupled limiting stages giving a true logarithmic detection characteristic. The output signal from the AGC-detector is routed to the Microcomputer Assembly for digitizing.

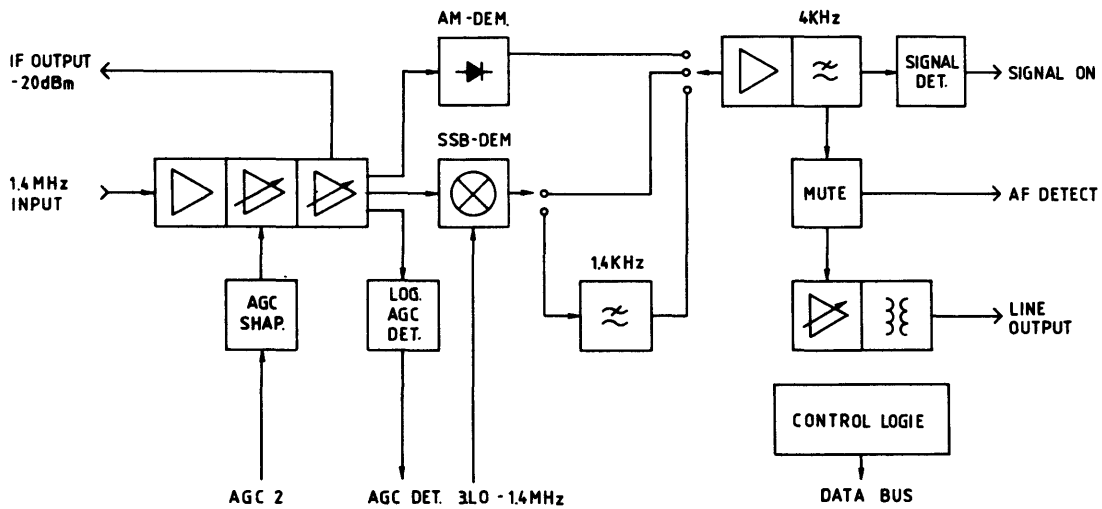

Figure 8.7 IF/AF Assembly

The output signals from the demodulators are routed through a mode switch selecting the desired reception mode. The mode switch further selects the 1.4 kHz low-pass filter used in the narr. and vnar. modes.

The output signal from the mode switch is 4 kHz low-pass filtered and applied to the mute circuit to enable the Microcomputer Assembly to mute the AF signal during Simplex transmission, switch sequences and squelch operation. Finally the AF signal is routed to the line output amplifier where the signal level is raised to a level of +10 dBm/600 Ω . The line level is adjustable from the rear panel of the assembly.

8.18 Microcomputer Assembly A8

The functional block diagram of the Microcomputer Assembly is shown in Figure 8.8

The assembly consists of an 8085 microprocessor largescale integrated circuit that controls all basic functions within the receiver.

The operating system software for the microcomputer is stored in three programmable read-only memories (PROM's). Each PROM is capable of storing 2k x 8-bit words.

Three random access memory chips (RAM's),

capable of storing 3k x 4 - bit words each, are required for the temporary storage and manipulation of input and output data. During power failure and receiver standby one of the RAM's is powered from a 3V battery back-up preventing interruptions from disturbing the stored data.

log loop provides a fast attack AGC2-level for the IF/AF Assembly. A digital AGC2-level is formed by an A/D-conversion (Successive approximation by D/A-conversion) of the analog AGC2-level, and controls the hold and decay parameters. The digital AGC1-level to

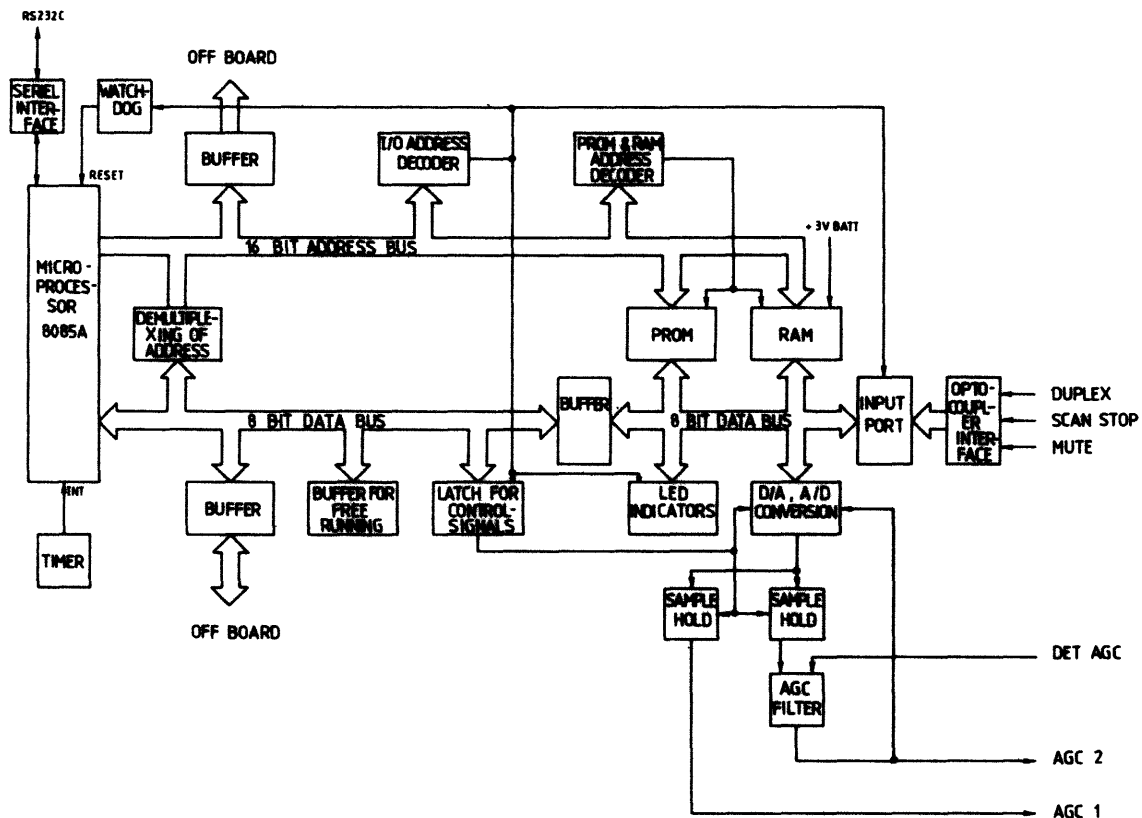

Figure 8.8 Microcomputer Assembly

Various buffers and decoders assure proper drive levels and timing to and from various circuits and input/output ports.

Timing of the assembly is via an 6.144 MHz crystal oscillator contained in the CPU chip.

The Microcomputer Assembly performs the automatic gain control. An ana-

the Front-end Assembly is derived from the digital AGC2-level.

8.19 Power Supply Assembly A10

The functional block diagram of the Power Supply Assembly is shown in Figure 8.9.

Part of the AF circuits, the notch filter and the AF power amplifier, are included in the assembly.

The AC mains is transformer-coupled to bridge rectifiers, followed by current limited voltage regulators (fold-back limited) delivering +5V, -15V and +15V.

lay, controlled by an optocoupler sensing mains drop-out. The DC to AC converter is enabled to operate at the same instant that the relay opens.

The regulated output voltages are controlled by the front panel on/off switch. When the switch is turned off the re-

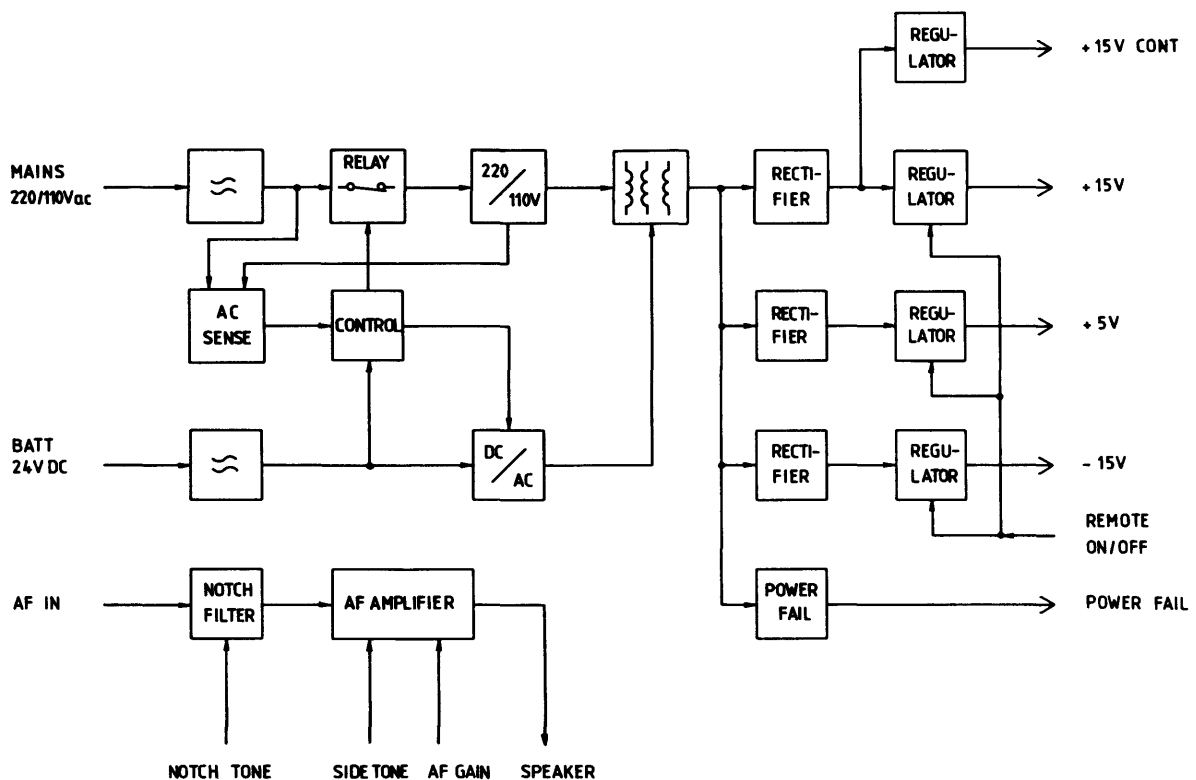

Figure 8.9 Power Supply Assembly

The power supply incorporates a floating inverter enabling the receiver to be driven by a 24Vdc source. The DC supply is converted to 80Hz ac and applied to a tertiary winding on the mains transformer.

The changeover between the mains supply and the DC supply is performed by a re-

ference voltage for the regulators is grounded, causing the output voltages to be removed, while the remaining part of the assembly will continue energized. An extra +15V regulator, servicing the optional oven-stabilized reference oscillator, is bypassed by the front panel on/off switch.

By means of an on/off switch positioned on the assembly rear panel the receiver may be deenergized. To avoid information loss during supply drop-out, a power failure circuit sensing the mains transformer secondary voltage, generates a look-ahead warning for the Microcomputer Assembly.

The AF part of the assembly contains a voltage controlled notch filter covering the range 300 Hz to 2700 Hz, a voltage controlled gain variable preamplifier and a 4W/4 ohm loudspeaker amplifier. A sidetone input, used during CW/SIMPLEX operation, is mixed with the preamplifier AF signal.

8.20 Front Panel Assembly A11A1

The Front Panel Assembly accommodates and interconnects most of the front panel controls, including power on-off/dimmer control, RF gain, AF gain, notch tune, mode select, bandwidth select, and receiver frequency/BFO tune. The LED's, meter read-out, and phone connector are also mounted on this assembly.

All digital controlled pushbuttons, the tuning knob information and the digi-

tized RF-gain setting are scanned by the Microcomputer Assembly. Synchronous the LED readouts and the front panel meter are updated. The assembly incorporates A/D-D/A converters for converting the analog RF-gain and meter information.

The only analog signals routed to and from the assembly are the DC-voltages controlling the notch tune and gain setting of the AF circuits, and the phone signal for the front panel mounted phone jack.

A single ribbon cable interconnects the assembly to the receiver mother board.

8.21 Mother Board A12A1

The receiver mother board ties all parts of the receiver together. It routes the front panel controls, the microcomputer controls and the stabilized voltages to the remaining assemblies.

Table 8.2a Key values during self-test

KEY DEPRESSED	VALUE DISPLAYED
SSB	11
AM	10
RTTY	12
CW	13
wide	18
inter	19
narr	1A
vnar	1B
off	20
slow	21
fast	22
att	24
scan	36
bfo	35
tune	34
C	37
comma	8A
0	80
1	81
2	82
3	83
4	84
5	85
6	86
7	87
8	88
9	89
rc1	31
sto	30
500	32
2182	33

Table 8.2b Fault Analysis Procedures

Find the symptoms below that match the fault condition and follow the hints. The assembly index is in table 8.3.

SYMPTOM	POSSIBLE CAUSE
1. Receiver dead. Mains OK. Fuse not blown. No LEDs lit.	A10 Power Supply. A11 Front Panel. on/off switch
2. Receiver dead. Mains OK. Fuse blown and new fuse also blows.	A10 Power Supply Diodes, series-transistors, 75V zener-diodes.
3. Front Panel dead. Noise is heard in the loudspeaker during power- up. No LEDs flashing on A8 back plane.	A8 Microcomputer A10 Power Supply 5V missing
4. Front Panel dead. Some LEDs flashing on A8 backplane.	A11 Front Panel
5. Display very weak. Receiver otherwise OK.	A11 Front Panel Dimmer Circuit. A10 Power Supply 8V missing
6. Part of display lights extremely bright while the rest is not lit. Receiver stops operation.	A8 Microcomputer 8085
7. The same display segment is missing in all figures.	A11 Front Panel Driver transistor Interconnection cable to motherboard
8. Display shows "FCS FAIL" and/or "FFFF.FF" steadily or periodi- cally. Pressing a key can cause an "OSC 1Err" read-out.	A10 Power Supply VBB, VEE or VFF drifting or incorrectly adjusted.
9. The display shows "An FAIL" during power-up or during keyboard operation.	Microcomputer-interface on An is faulty.

Table 8.2b (continued)

SYMPTOM	POSSIBLE CAUSE
10. "OSC 1 Err" during frequency or mode changes.	A1 Synthesizer. VCO out of lock.
11. "OSC 2 Err"	A2 Standard. 73.6 MHz oscillator out of lock.
12. "OSC 3 Err"	A2 Standard. 1.4 MHz oscillator out of lock.
13. Receiving Frequency incorrect. No error read-outs.	A1 Synthesizer. Digital circuits. A2 Standard. 40.96 kHz reference.
14. Sensitivity poor.	Signal Path. Oscillator levels.
15. Sensitivity poor. Receiver runs testprogram without error read- outs.	Antenna cable. A4 Preselector. Input protection. Range switches.
16. "An FAIL" during testprogram.	Microcomputer-interface on An is faulty.
17. "OSC 1 Err" during testprogram. No errors during normal operation.	A1 Synthesizer. VCO range switch. VCO adjustment.
18. "GAin Lo" 5 times followed by "SEnS Lo" one time during testprogram.	The signal-path gain is low. A3 Front-end. A7 IF/AF. A1 Synthesizer output level. A2 Standard. 73.6 MHz level. Interconnection cables.
19. "GAin Lo" and "no Audio" 5 times followed by "SEnS Lo" one time during testprogram.	Same as 18.
20. "GAin Lo" and "no Audio" 5 times during testprogram.	A1 Synthesizer frequency wrong, digital error.

Table 8.2b (continued)

SYMPTOM	POSSIBLE CAUSE
21. "no Audio" during testprogram. The loudspeaker output is weak and distorted.	A2 Standard. 1.4 MHz level or frequency. A7 IF/AF demodulator. Interconnection cable.
22. "GAIN Lo" in one of the bandwidths during testprogram.	A3 Front-end crystal filter.
23. "SENS Lo" during testprogram. Sensitivity poor.	A4 Preselector range switches. Interconnection cable to A3. A3 Front-end input amplifier or lo amplifier.
24. "SENS Lo" during testprogram. Receiver operates normally.	This is not necessarily a fault, but can be caused by temperature drift in the AGC-circuits.
25. "no Audio" during testprogram. Receiver operates normally.	Same as 24. + A7 IF/AF AGC detector not adjusted for -20dBm output from A7J2. Audio detector.
26. Audio distorted in AM.	A7 IF/AF demodulator. AGC detector not adjusted for -20dBm output from A7J2.
27. Audio missing or weak. No error read-outs during testprogram.	A10 Power Supply. Audio amplifier. A11 Front Panel AF potentiometer Interconnection cable to motherboard.
28. Receiver acts strange when pressing certain keys.	A8 Microcomputer 8085 or EPROMS.
29. Receiver loses user-programmed channels.	A8 Microcomputer Battery run out. CMOS RAM faulty.
30. "FCS FAIL" during power-up.	A8 Microcomputer RAM circuits faulty.

Table 8.3 Assembly Index

ASSY NO	ASSY NAME	THEORY OF OPERATION	COMPONENT ID	SCHEMATICS
NA	Oceanic Interconnection	NA	NA	Service Sheet 1
A1	Synthesizer	Service Sheets 2, 3, 4, 5	Service Sheets 2, 3, 4, 5	Service Sheets 2, 3, 4, 5
A2	Standard	Service Sheets 6, 7, 8, 9	Service Sheets 6, 7, 8, 9	Service Sheets 6, 7, 8, 9
A3	Front-end	Service Sheets 10, 11, 12, 13	Service Sheets 10, 11, 12, 13	Service Sheets 10, 11, 12, 13
A4	Preselector	Service Sheets 14, 15, 16	Service Sheets 14, 15, 16	Service Sheets 14, 15, 16
A7	IF/AF	Service Sheets 17, 18, 19	Service Sheets 17, 18, 19	Service Sheets 17, 18, 19
A8	Microcomputer	Service Sheets 20, 21, 22, 23, 24, 25, 26, 27	Service Sheets 20, 21, 22, 23, 24, 25, 26, 27	Service Sheets 20, 21, 22, 23, 24, 25, 26, 27
A10	Power Supply Interconnection	NA	NA	Service Sheet 28
A10A1	Power Supply	Service Sheets 29, 30	Service Sheets 29, 30	Service Sheets 29, 30
A10A2	Power Supply	Service Sheet 31	Service Sheet 31	Service Sheet 31
A11A1	Front Panel	Service Sheets 32, 33, 34, 35, 36	Service Sheets 32, 33, 34, 35, 36	Service Sheets 32, 33, 34, 35, 36
A11A1 A1	Display	Service Sheet 37	Service Sheet 37	Service Sheet 37
A12A1	Mother Board	Service Sheets 38, 39, 40	Service Sheets 38, 39, 40	Service Sheets 38, 39, 40

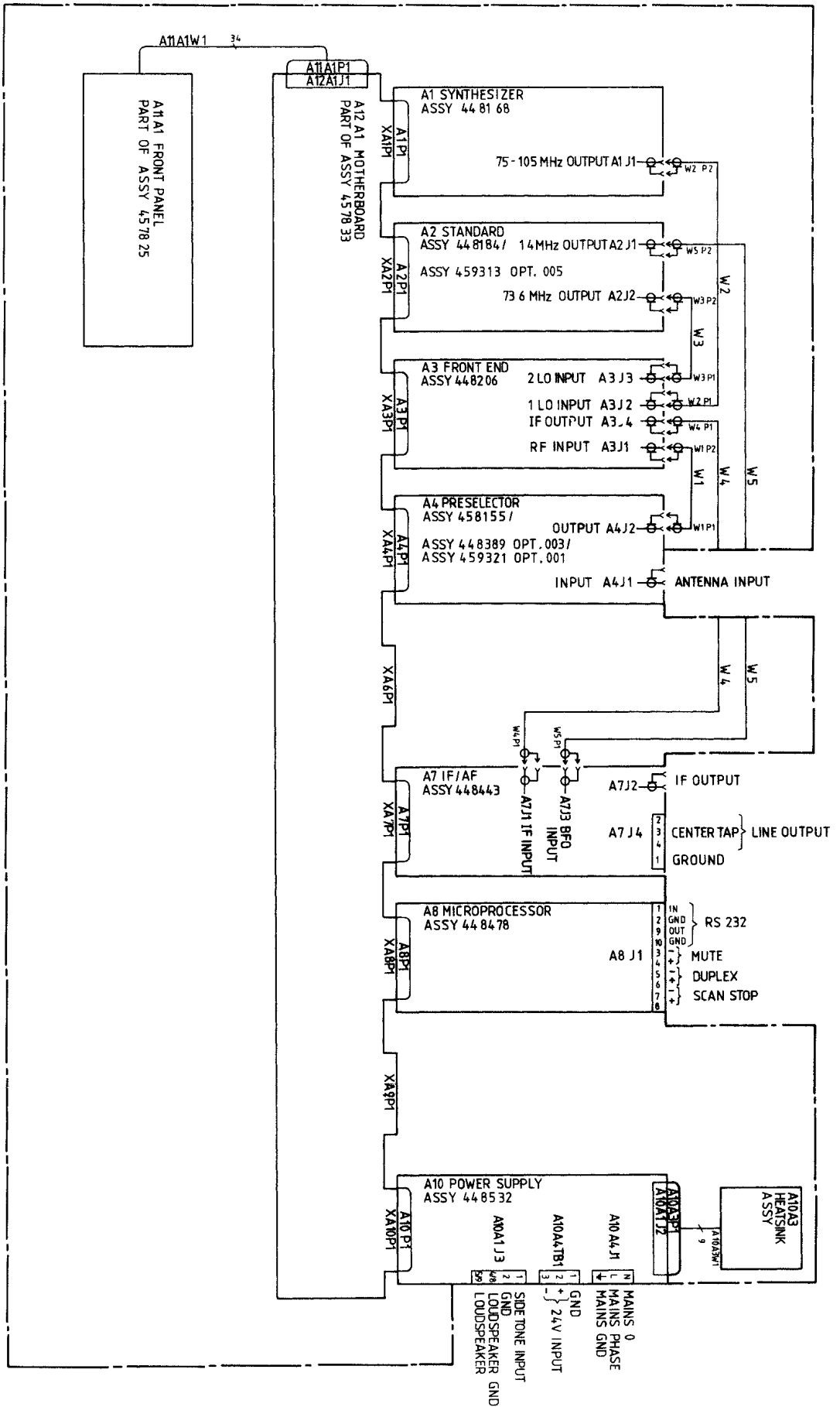

INTERCONNECTION
DIAGRAM

DRAWING NO
45 78 41

SHEET 1

Service Sheet 1

① Phase Detector

The J-k flip-flop U31 forms a set-reset phasedetector, switching the differential transistor pair Q₁, Q₂. U-31 is clocked by the reference signal, 40.96 kHz negative going impulses, turning the diode switch CR4 "ON". CR4 is connected to a constant current generator, making the Ramp Generator ramp up. U31 is preset by the frequency divided signal from the VCO, terminating the ramp up period.

② Ramp Down Switch

The ramp down period is controlled by the diode switch and has the length of 832 VCO-cycles. The voltage at TP2 is 2.0 V in the ramp down period and -1.2 V in the remaining time.

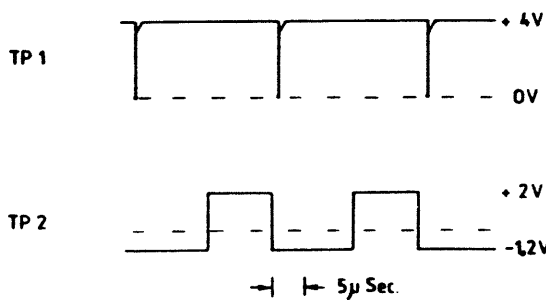

③ Ramp Generator

The ramp generator is an inverting current generator built with discrete components to ensure fast response and low noise.

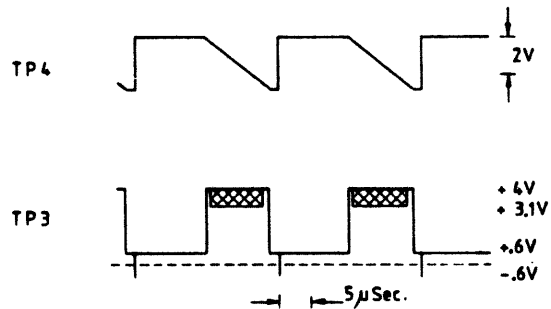

④ Summing Amplifier

The current from the constant current generator U29, Q35 is added to the current from the resistance network R128-R139 by the summing Amplifier U30, Q40. The current from R128-R139 is controlled by the diode switches CR19-CR21.

⑤ Supply Filtering

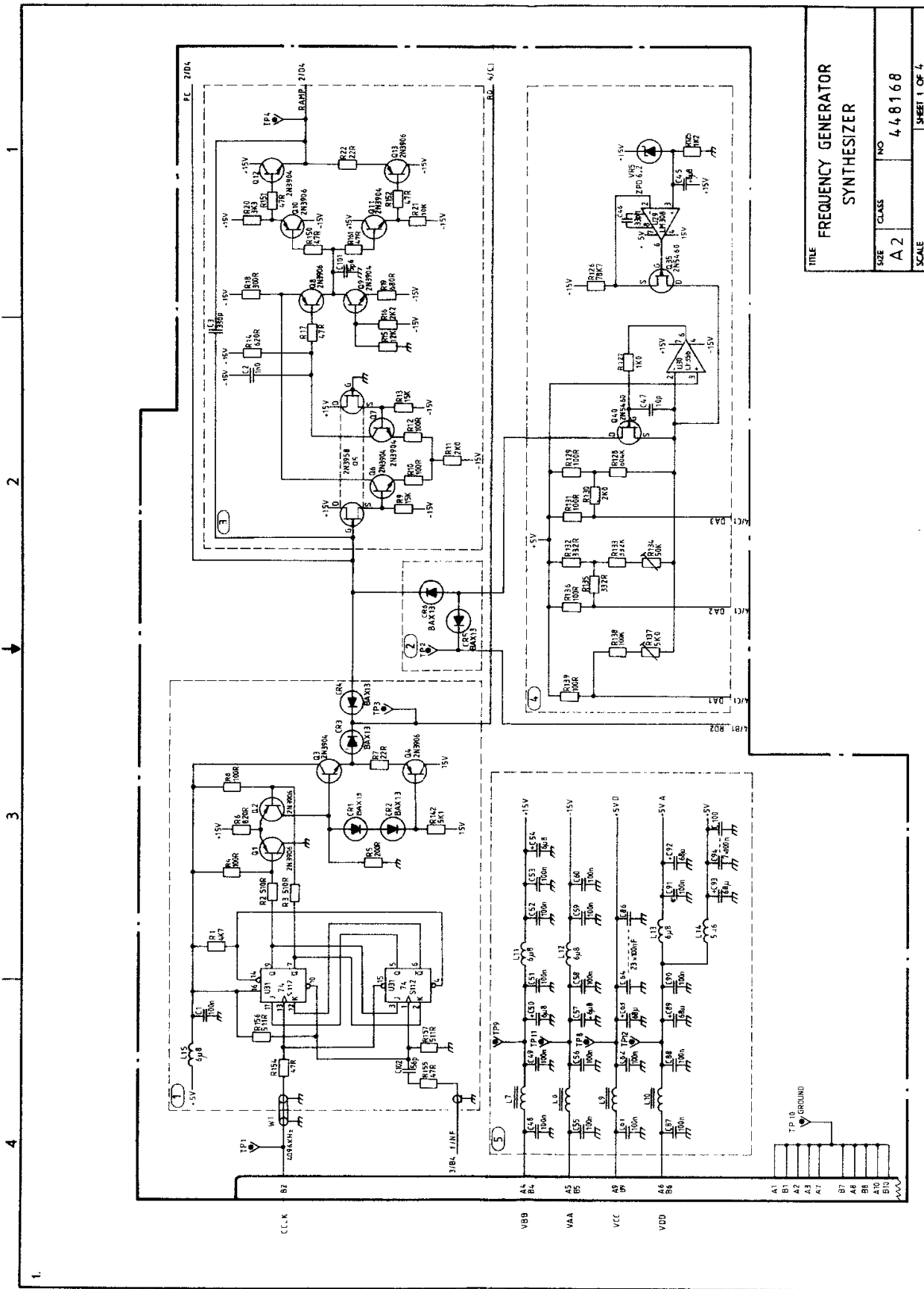

TITLE		FREQUENCY GENERATOR SYNTHESIZER	
SIZE	CLASS	NO	SCALE
A2		448168	
SHEET 1 OF 4			

⑥ Sample and Hold

The transistor pair Q_{15} , Q_{16} generates the gate voltage to the first sample switch Q_{14} . The voltage at C_4 is transferred to the sample capacitor C_5 by the second switch Q_{17} . The signal at TP5 is positive going impulses with a frequency of 40.96 kHz. At the output of the unity gain amplifier U28, the voltage is between -9V and +10V

⑦ Loop filter

Active second order Lowpass filter, $f_{cut} \approx 3$ kHz.

⑧ VCO - Supply

The voltage at TP7: -7.5 V.

⑨ Voltage Controlled Oscillator.
Assy 455490.

The 75 MHz - 105 MHz VCO is controlled by a voltage between -9V and +10V. R149 and CR22 are inserted for linearisation of the voltage-frequency function. The frequency range is divided into 4 sub-ranges by switching the fixed capacitors C_{19} and C_{20} .

The VCO control voltage, TP6, may be adjusted by the coil L 1. With the receiver tuned to 29.99 MHz, the voltage shall be +10.0 V at $t_{amb.} = 25^{\circ}C$.

Service Sheet 3, A1

8-22

⑩ Range Shift

The Range Shift shall be in accordance with the following table:

Frequency	Voltage at C_{15}	Voltage at C_{16}
15kHz-5999.99kHz	-8.2V	-8.2V
6000kHz-11999.99kHz	+15V	-8.2V
12000kHz-19999.99kHz	-8.2V	+15V
20000kHz-29999.99kHz	+15V	+15V

⑪ Lock Detector

The output of the Lock Detector is high when the VCO control voltage is between -9.5V and 11.5V. Outside this range the output is turned low.

⑫ Output Buffer

The necessary amplification and isolation is provided by the output Buffer U26. Unwanted spurious and harmonic outputs are attenuated by the band-pass filter L_5 , L_6 and the attenuator R_{62} - R_{64} insures a low VSWR. The output is attenuated app. 60 dB by activating Q_{26} .

⑬ Isolation Amplifier

The signal from the output Buffer is fed through the cascode configuration Q_{27} , Q_{28} to protect the VCO from noise generated by the Prescaler.

TITLE
**FREQUENCY GENERATOR
 SYNTHESIZER**

SIZE CODE IDENT DRAWING NO
 A1 448168

SCALE 2:1 SHEET 1 OF 1

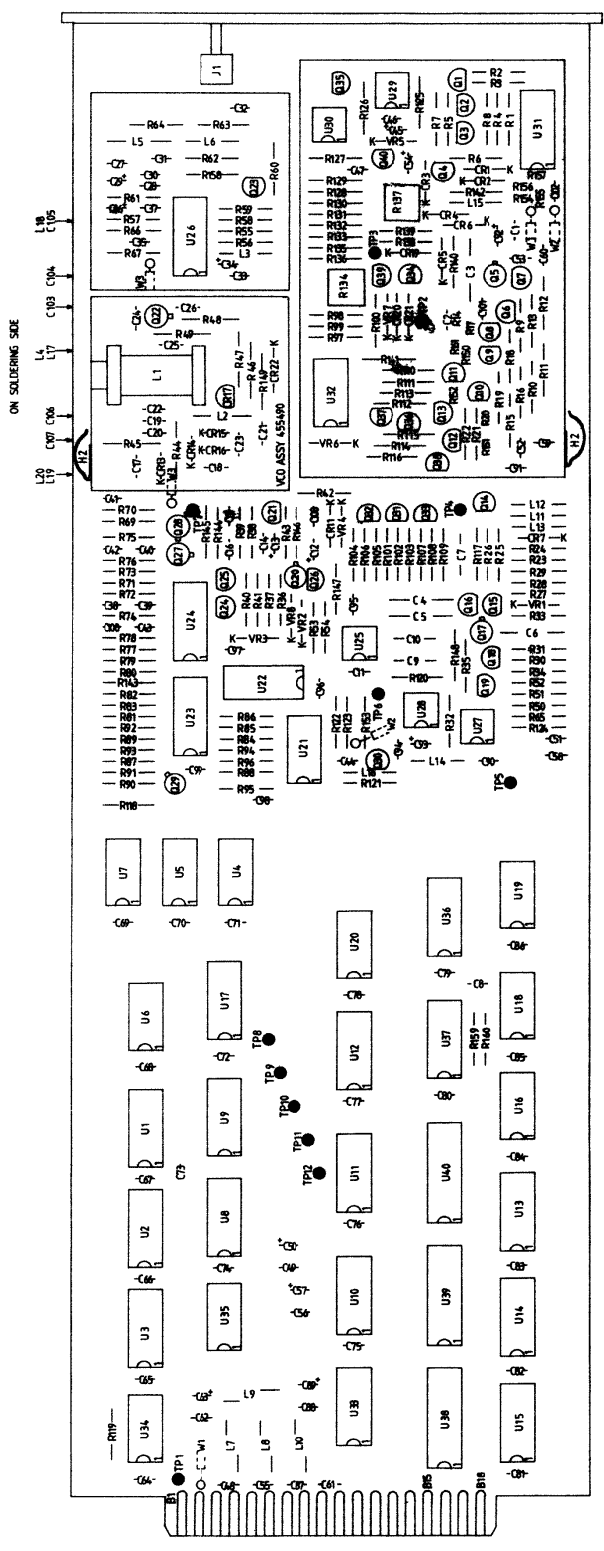

1 2 3 4

1 2 3 4

D C B A

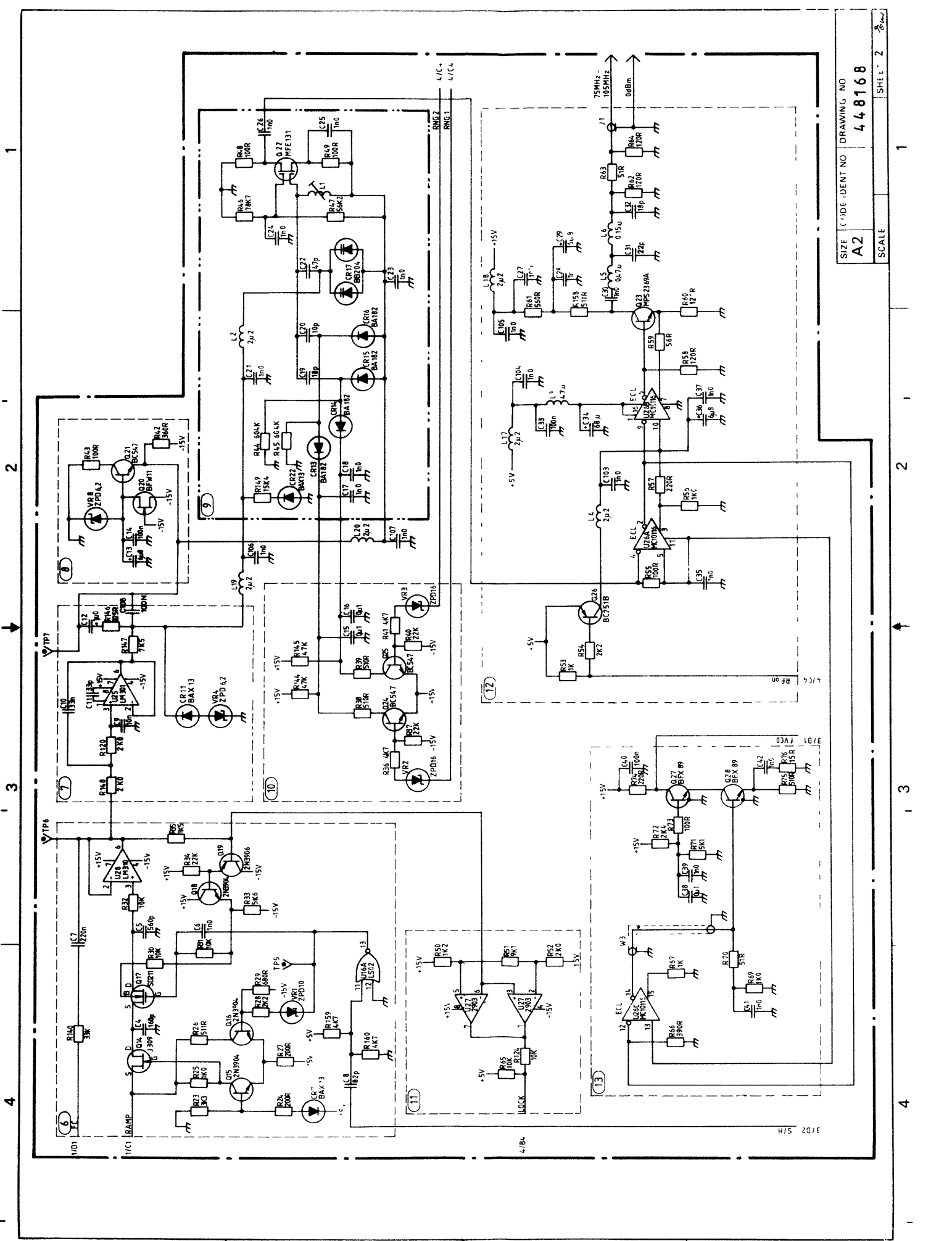

SIZE	CODE	IDENT NO	DRAWING NO
A2			448168
SCALE			SHEET 2

ON SOLDERING SIDE

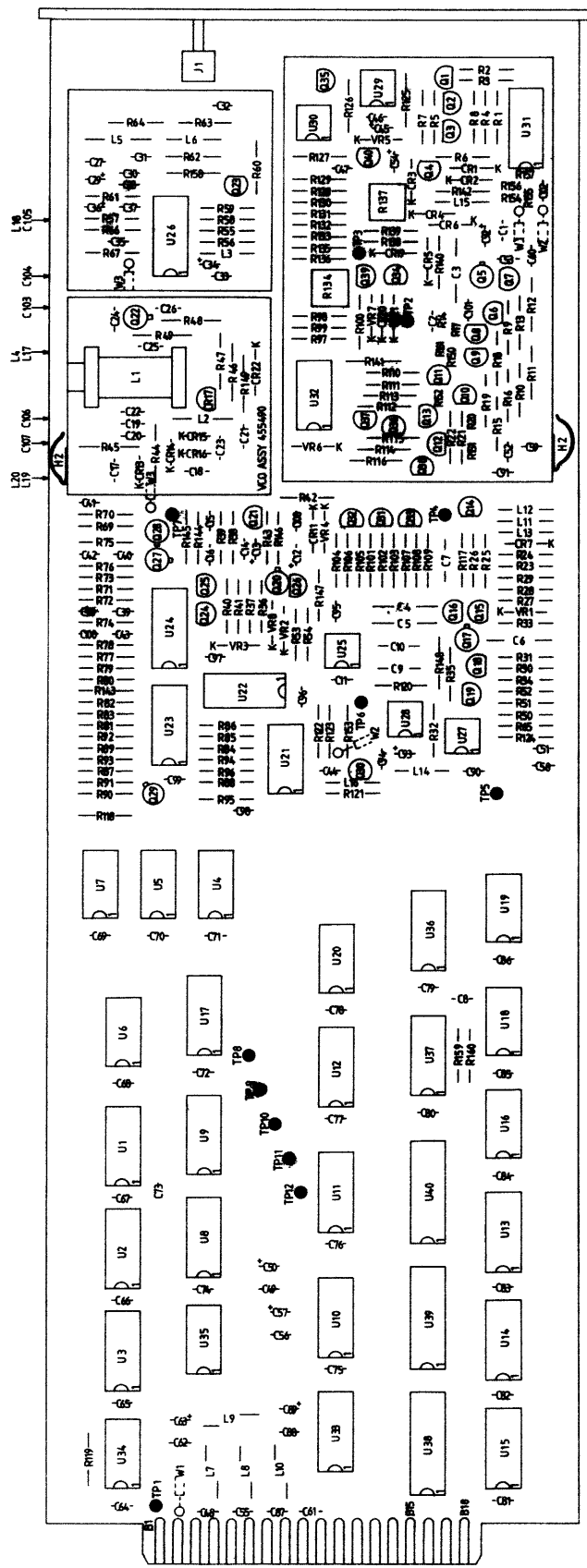

TITLE
FREQUENCY GENERATOR
SYNTHESIZER

SIZE	CODE IDENT	DRAWING NO
A1		448168
SCALE	2:1	SHEET 1 OF 1

14 Prescaler

The prescaler has a divide ratio of $N=16$ or $N=17$ depending on the logical level of U16 pin 10. ECL to TTL conversion is provided by Q_{29} . Noise from the Prescaler is isolated from the Phase Detector by the inverter Q_{30} .

15 Synchronizer

The synchronizer generates the timing signals for the sample and hold, ramp down, D/A conversion and pulse removal. One cycle of the Synchronizer is similar to one reference cycle. (24.4 μ -sec.). One reference cycle contains 1831-2563 VCO cycles, depending on the tune frequency. The reference cycle is defined at the negative transition of U21 pin 5. When 1536 VCO-cycles remain in the reference cycle, U18A is clocked and the sample and hold circuit is activated. When 1280 VCO-cycles remain, the decode counter U17 starts counting, defining the time for the ramp down period. The D/A conversion for the phase compensation is started when 1216 VCO-cycles remain (U19 pin 9). In case of an overflow from the adder U12, the pulse removal will take place when 192 VCO-cycles remain. The pulse remove signal is present at U20 pin 9.

16 Pulse Swallowing Counter.

The counter is built by 3 4-bit counters and 1 flip-flop. When the down counter U15 reaches 0000, U15 is reset

by U18B and the counter ratio for the Prescaler is changed from 17 to 16. The counter ratio N is loaded into the counters in binary code.

The binary code is split into a 4-bit code A and a 8-bit code P . Thus the wanted ratio is

$$N = P \times 16 + A.$$

At the start of the reference cycle all counters are loaded. The first $A \times 17$ VCO-cycles the Prescaler ratio is 17. U15 is reset and U14, U13 go on counting the remaining $(P-A) \times 16$ VCO-impulses. The result is

$$A \times 17 + (P-A) \times 16 = P \times 16 + A = N.$$

When all counters reach the zero state, U13 pin 13 goes low. After 1 Prescaler cycle = $16 \times$ VCO cycles, U21 pin 5 goes low, loading all 3 counters. After 2 Prescaler cycles, the load signal is inhibited and the count down period starts. As loading takes 32 VCO cycles, the counter must be programmed to the desired ratio minus 32.

17 Rate Counters

For each reference cycle, the content of the latches U8, U9 is loaded into the binary counters U1-U3. In the ramp down period, U1-U3 are counted down with a frequency $f_{VCO}/64$. When they reach the zero state, they are reset by an external flip-flop. Each counter corresponds to 4 bits of the latches U8, U9 and the period of time in which the counters are active is proportional to

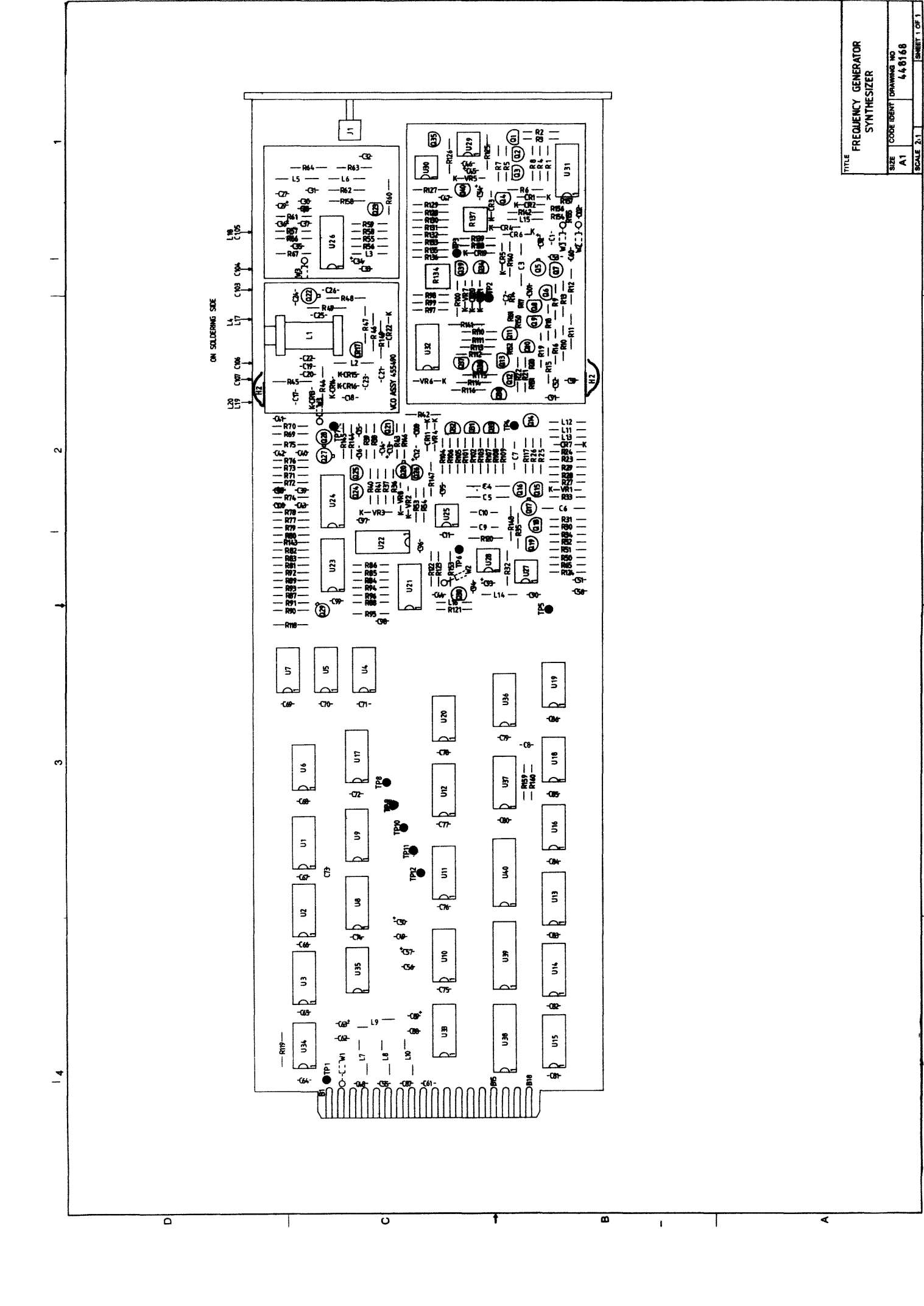

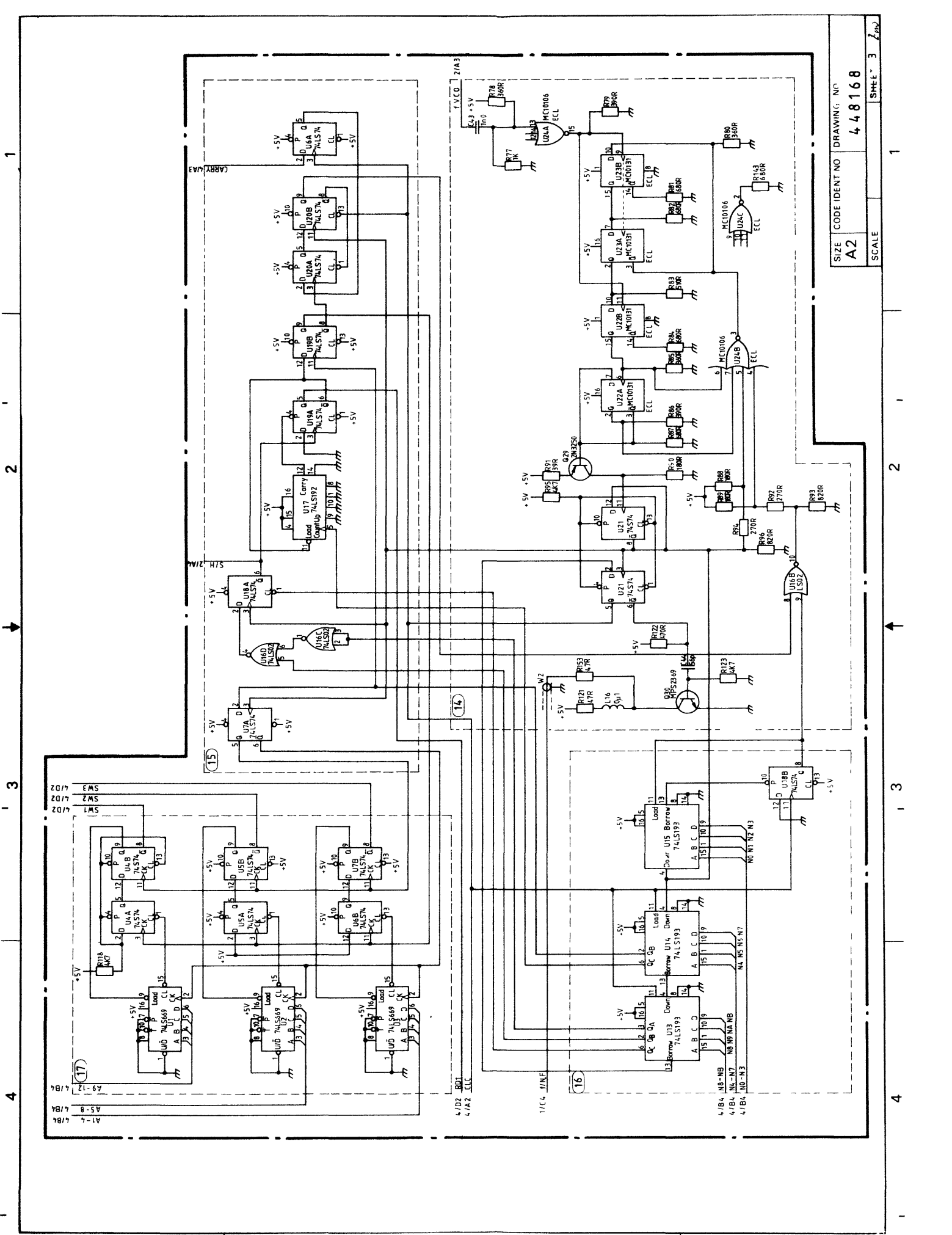

SIZE CODE IDENT NO DRAWING NO
A2 **448168**

SCALE
 SIMIL 3 2nd

18 Current Generators.

3 current sources are used for the D/A conversion and the ramp up. The FET Q_{39} is inserted to insure a high output impedance.

19 Adder/Accumulator

For each reference cycle, the latches U8, U9 are clocked and the fraction part, present at the input of the adders U10-U12, is added to the content of the two latches. When the adders overflow, the Synchronizer is activated and one pulse is removed in the counting sequence.

20 Current switches

The current switches Q_{31} - Q_{33} are operated from the Rate Counter, U4, U5, U7.

The current switched by Q_{33} is also used as ramp up current for the Ramp Generator.

Consequently, the ramp up current and the current for the D/A conversion of the most significant 4-bits is the same current.

Q_{36} - Q_{38} generates the switch voltages for the ramp up D/A switch Q_{34} .

21 Interface

The data selector U33 selects the wanted input or output latch.

The 24-bit frequency information is available at the output at U38-U40.

The input latch U36 sets the frequency range and the RF ON/OFF. At the output latch U37, the "out of lock" signal is checked, and the overflow indication from the adders U10-U12 is available at U37 pin 4.

ON SOLDERING SIDE

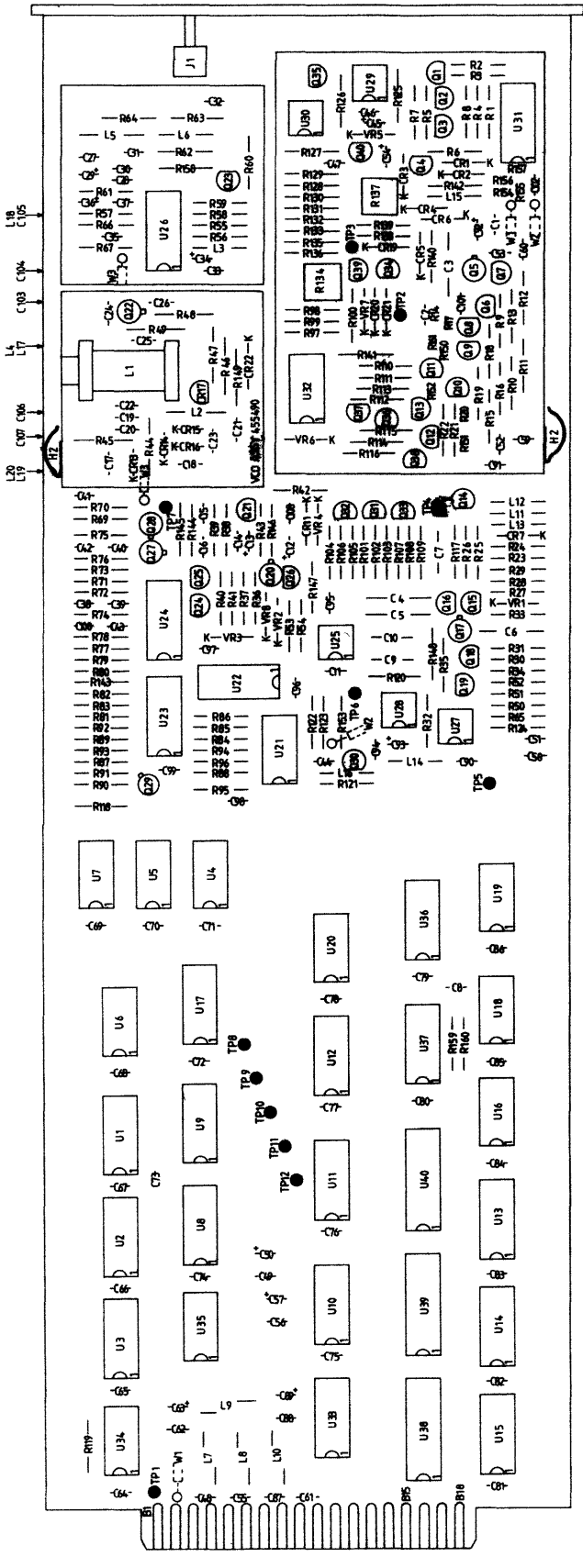

TITLE		FREQUENCY GENERATOR SYNTHESIZER	
SIZE	CODE IDENT	DRAWING NO	44 6168
A1			
SCALE	0.1		
SHEET 1 OF 1			

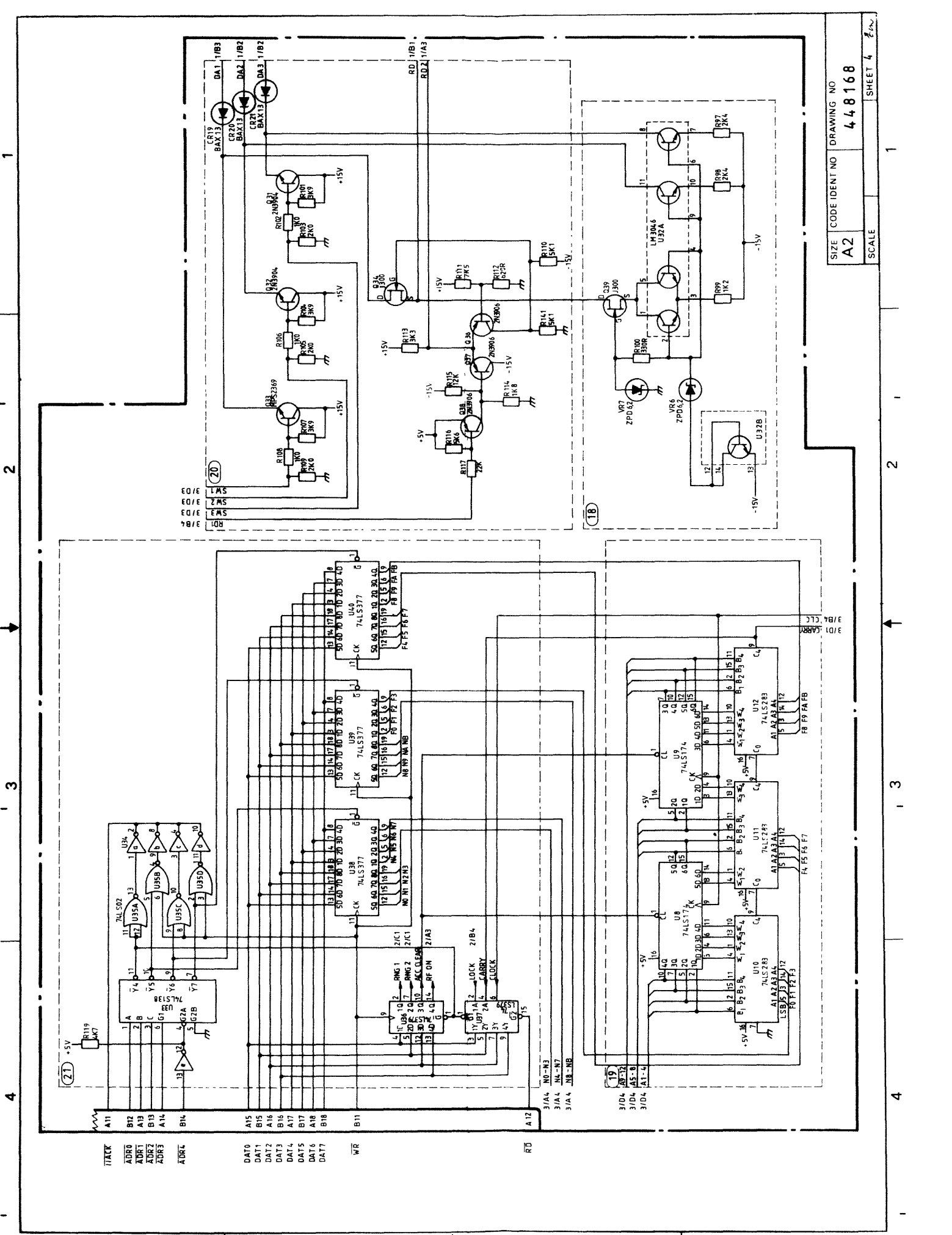

1
2
3
4

1
2
3
4

D
C
B
A

SIZE CODE IDENT NO DRAWING NO
A2 448168

SCALE SHEET 4

1 2 3 4

ON SOLDERING SIDE

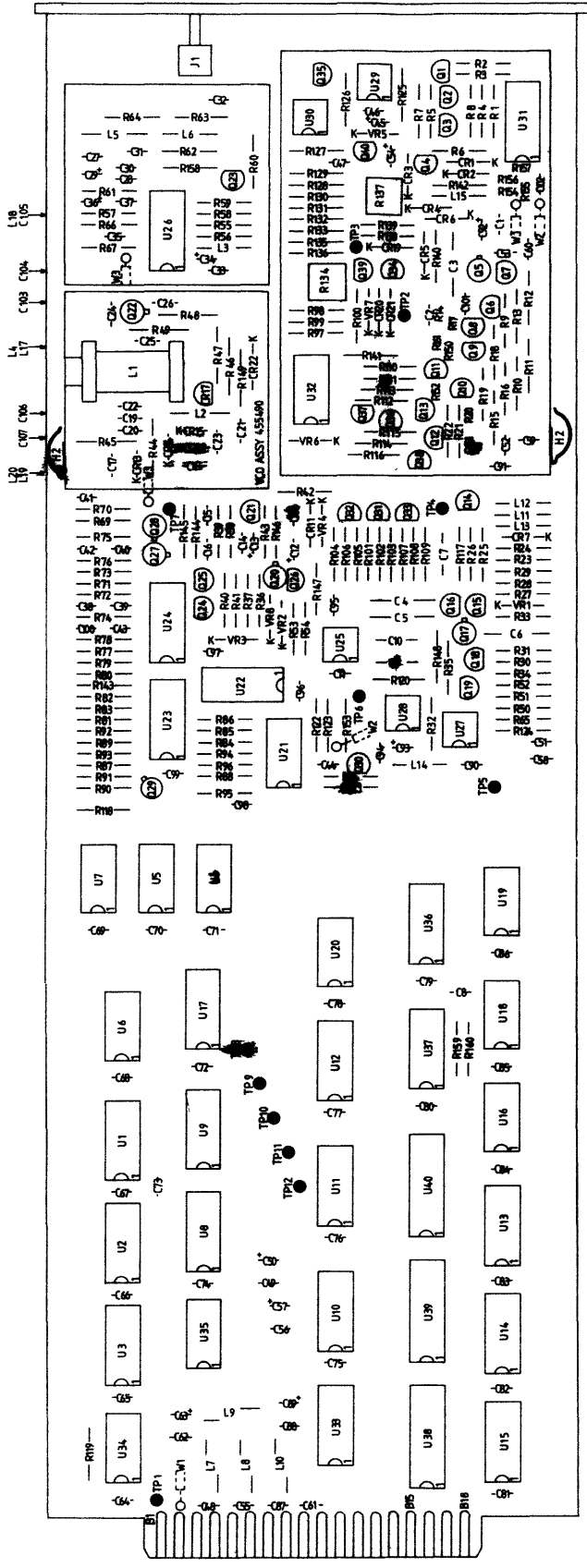

TITLE
FREQUENCY GENERATOR
SYNTHESIZER

SIZE
A1

CODE IDENT DRAWING NO
44 8168

SCALE 2:1

1

2

3

4

D

C

B

A

1 Phase-Frequency Detector

U23 generates a matched set of currents. One for the current translator U19, Q8, two times this current to Q9, and a reference current to the D/A converter U22. The current from Q8 acts as a ramp up current for C29. R60, 61, 62 limit this function. The ramp down current from Q9 is controlled by the switches CR5, CR6. The ramp down time is dependent on the count down VCO signal. This is performed by a set-reset function, U18a and Q7. The wave form in TP10 is approximately triangular. This is fed to the loop integrator U20, C31, C32, R65 by R62. The loop bandwidth is approximately 800 Hz. The diodes CR7, VR3 reduces saturation time in the loop. To reduce 40.96 kHz sidebands a second order low pass filter with a cut-off frequency at 2.5 kHz is added, U21, R66 - 67, C33 34.

2 1.4 MHz VCO

Q11, Q12 form an oscillator with tuned circuit, L17-18, C39, C40 in the collector of Q11. The feedback is performed between the emitters of Q11 - 12. A buffered output is taken from Q12 via a low Q tuned circuit L22,

C42 - 43. The voltage controlled capacitance diodes CR8, CR9 allow a tuning range at approximately 6.8 kHz/V. The nominal DC voltage at TR11 is +3V at 1,400 MHz adjusted by L18 at 25°C room temperature.

3 Output Amplifier

0dBm 50 ohms output is provided by Q13 with the tuned circuit L19, C48, L20. R87 - 88 - 89 is a 3dB attenuator which gives a more exact 50 ohm output impedance.

Q14 allows RF ON/OFF switching, with approx. 50dB attenuation.

4 Buffer-Translator.

Q15-16 is an emitter coupled amplifier, which gives excellent isolation between the counter and the VCO. The output level is a 0-5V square wave.

5 Lock Detector.

The control voltage to the VCO is feed to a window detector U17a-b. The loop is within proper conditions if the voltage in TP11 is $0V < TP11 < +6V$. Under this condition Q17 gives a HIGH, TP14.

6 API Generator

The D/A converter (U22), forms a part of the API system (analog phase interpolator). It converts the 8 bit phase information from the adder in 8 to a ramp current. This current is converted to a voltage by R61, and injected to the loop by R60. It is adjusted to eliminate the stepped ramp error signal arising from the fractional system 8

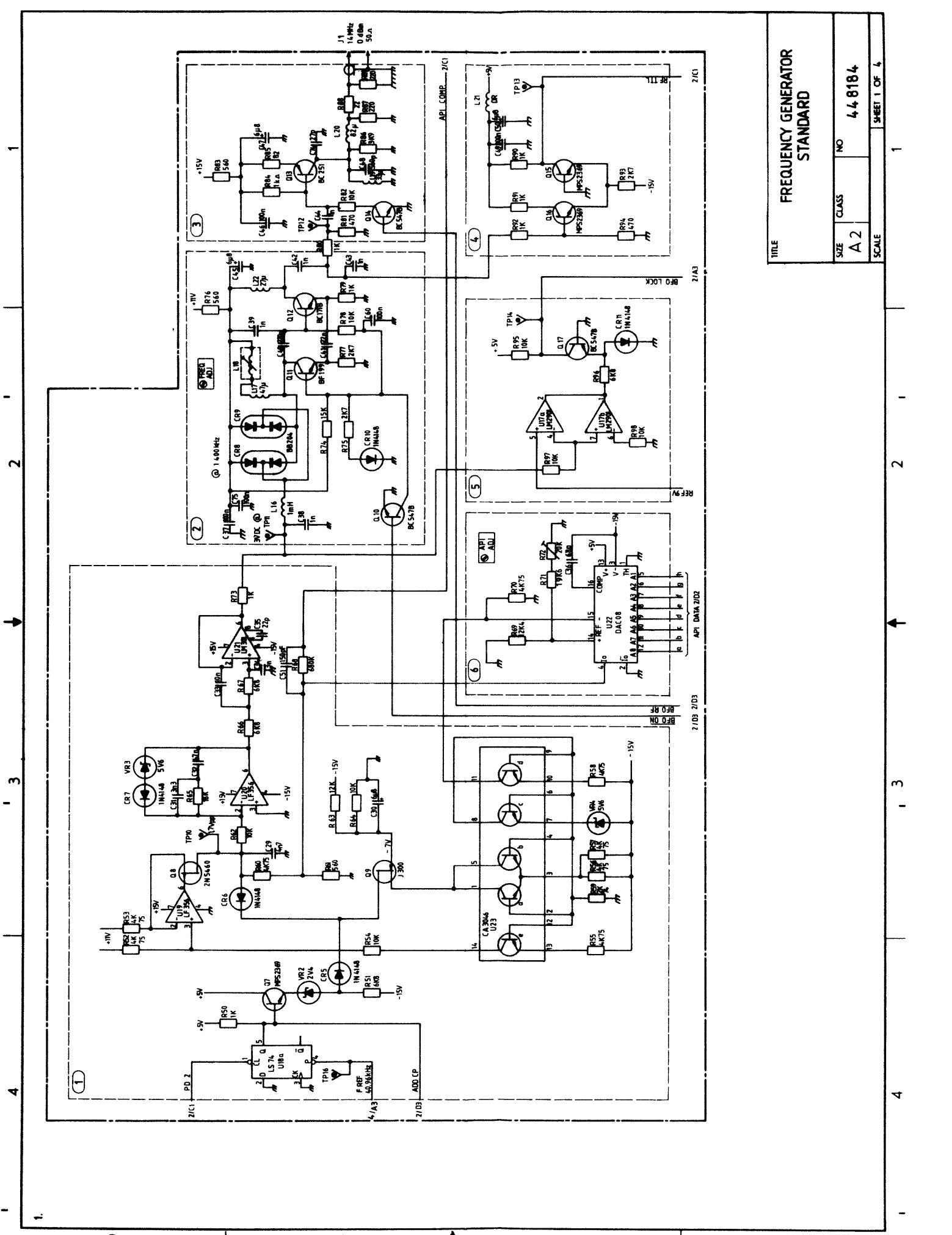

TITLE			
FREQUENCY GENERATOR STANDARD			
SIZE	CLASS	NO	
A 2		448184	
SCALE			SHEET 1 OF 6

7 Loop Divider.

This divider works in two modes. Divide by 34 or 35. When the fractional part is zero (input to U32 - 33 - 35 equal 0), the counter continuous divides by 34. The output frequency is then $34 \times 40,96 \text{ kHz} = 1392,64 \text{ kHz}$. In general the average output frequency is set by;

$$F_o = \left(34 + \frac{F}{4096} \right) 40,96 \text{ kHz}$$

where $F = 0-4095$ (fractional part).

If $F = 1$, 4096 reference pulses will elapse before the counter receives one divide by 35 instruction. This means that the phase-detector will receive an instruction for raising the frequency each $4096 \times \frac{1}{40,96} \text{ kHz} = 0,1 \text{ sec}$.

The average frequency will rise 10 Hz. For $F = 2$, 20 Hz and so on. For $F_o = 14000,0 \text{ kHz}$, $F = 736$.

8 Adder and Phase Accumulator.

The fractional part consists of 3 cascade coupled 4 bit adders connected to 3 x 4 bit latches. On receiving a reference clock, the data present on the data inputs of the latches will be transferred to the Q outputs. An addition will occur between these outputs and the data present on the frequency set inputs. After $4096/F$ additions U35

will give an overflow which is used to change the counter to divide by 35 (the same as removing 1 VCO clock cycle). The contents of the data latch U30-31-34 gives phase information that, converted in **6** will show a stepped ramp function similar to the error in the loop when the API is disconnected.

9 Microcomputer Interface.

U28 - U29 converts the 8 bit data bus to 14 bit data information. 11 bits for BFO frequency set, 1 for BFO RF ON/OFF switching. U27 reads BFO lock, 73,6 MHz lock, 10,24 MHz level and fractional control, and transmits them to the microprocessor. U24, U25, U26 is an address key system.

TITLE
**FREQUENCY GENERATOR
 STANDARD**

SIZE CODE IDENT DRAWING NO.
 A1 448184

SCALE SHEET 1 OF 1

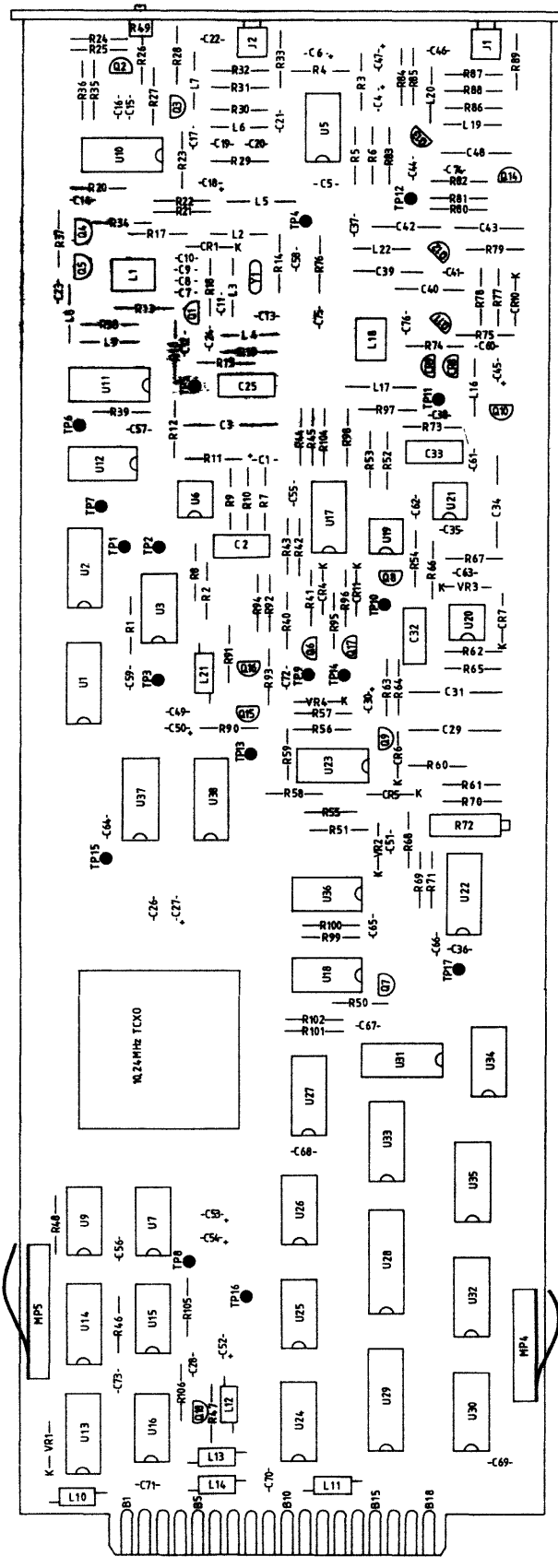

1 2 3 4

1 2 3 4

D C t B A

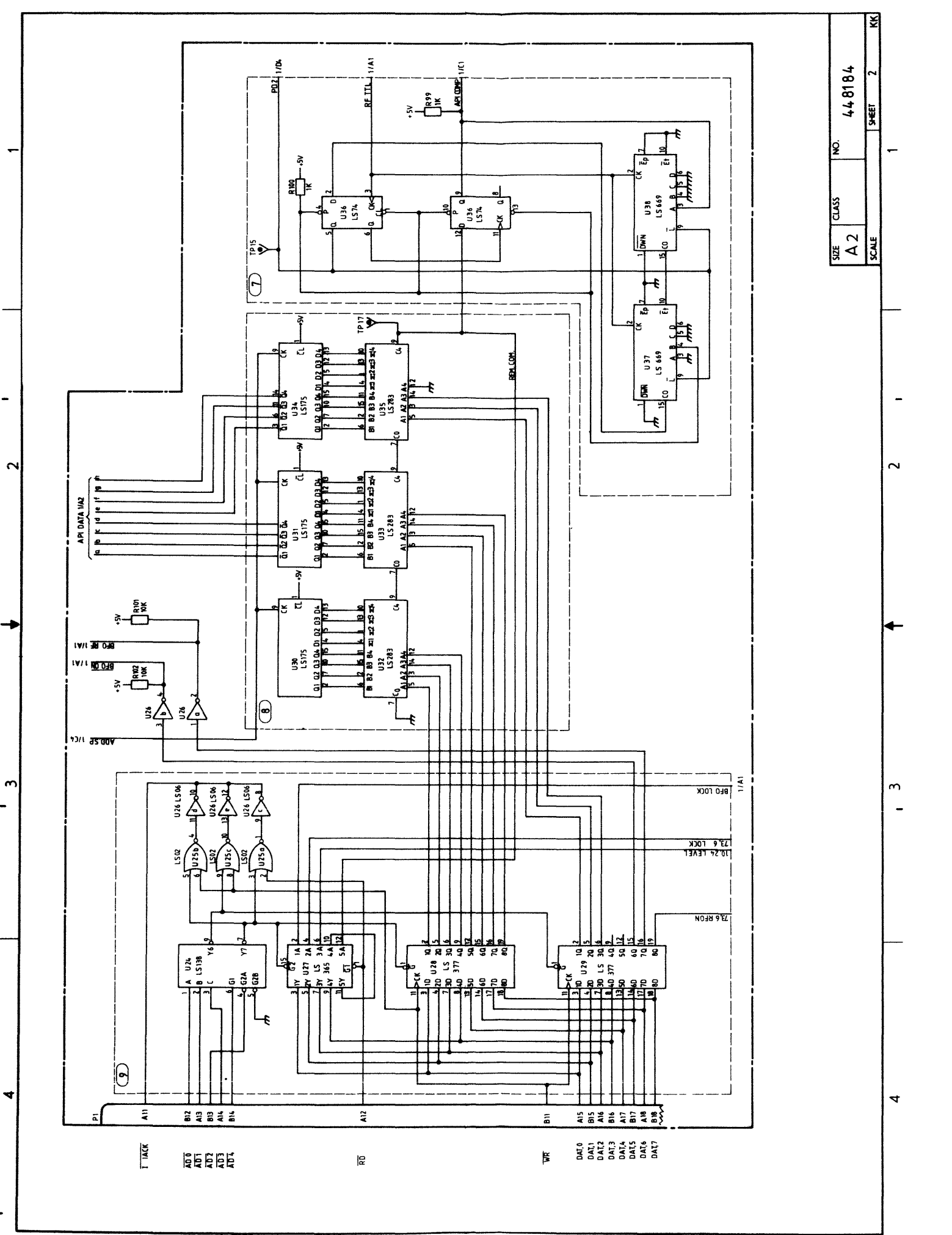

SIZE	CLASS	NO.	44 8184
A2			
SCALE		SHEET	2
			KK

1 2 3 4

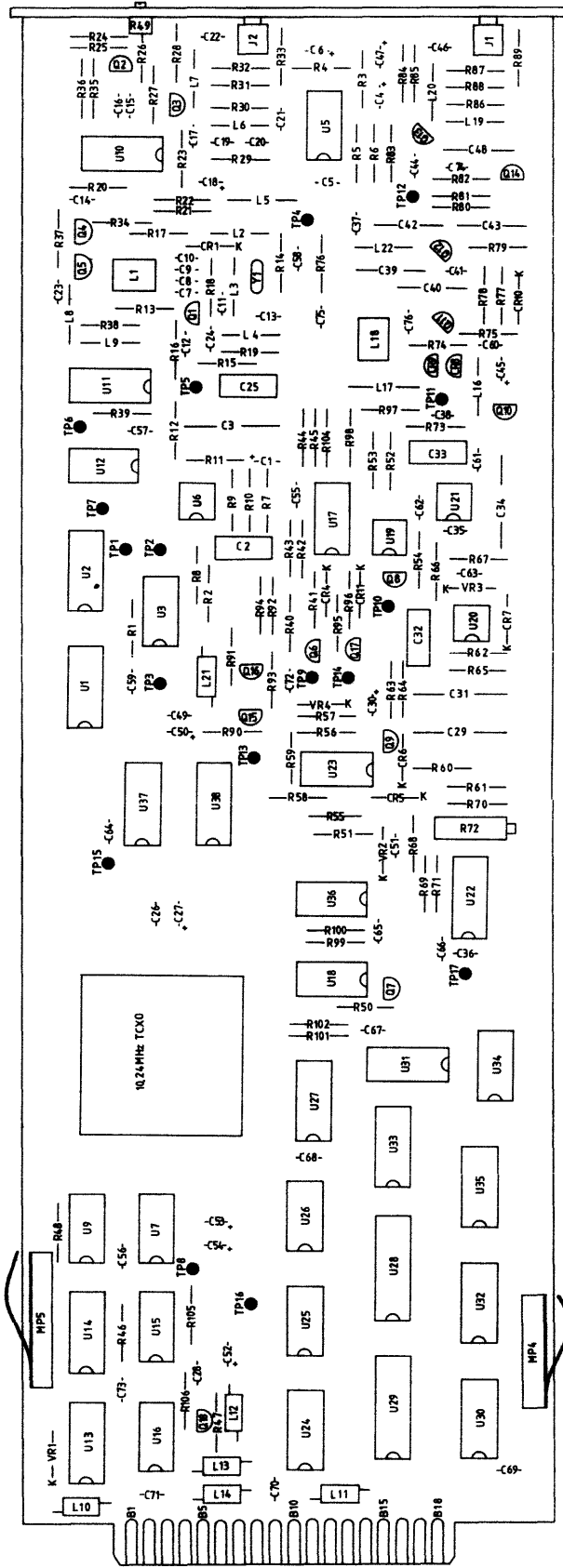

TITLE		FREQ. GENERATOR	
DRAWING NO.		STANDARD	
SIZE	CODE	IDENT	DRAWING NO.
A1			4.4.818.4
SCALE			SHEET 1 OF 1

1 2 3 4

D C B A

(10) Divider.

U1 - 2 -3 divides the input frequency of 3,68 MHz by 115 to give 32 kHz (31,25 nS) at TP1. This signal feeds the phase/freq. detector. The signal at TP1 is a negative pulse with a width of approximately 270 nS.

(11) Phase-Frequency Detector.

U3 performs a SET-RESET phase/freq. detector. It compares the 32 kHz from U1 - 2- 3 (TP1) with a reference signal from U9b, TP3. The output at TP2 is a duty cycle controlled square wave with a frequency of 32kHz.

(12) Fine Regulator.

The +15V is stabilized to a +11V low noise reference for the 73,6 MHz VCXO and the 1.4MHz VCO.

(13) 73,6 MHz VCXO.

The X-tal Y1 operates in series-resonant mode with the voltage controlled circuit CR1, L2. It forms the feedback path in the oscillator formed by Q1 and the low Q tuned circuit L1, C8, C9. L3 eliminates the parallel capacitance in Y1. U10c ECL amplifier operates as buffer amplifier. The tune voltage in TR5 is nominally adjusted to +4V by L1, at 25°C room temperature.

(14) Output Amplifier.

The 73,6 MHz +7 dBm output is provided by 1/3 ECL amplifier U10c and Q3 with the tuned circuit L2, L19, L7. R31-32-33 is at 3 dB attenuator which give a more exact 50 Ω output. An RF ON/OFF switch function is performed by U16 and Q2. The output is disabled by approx. 60 dB.

(15) ECL to TTL Translator.

U10b performs an isolation and driver amplifier for Q4, Q5 emitter coupled amplifier. L8, L9, R38 is a peaking circuit.

(16) Prescaler.

U11 divides by 4. The output is 18,4 MHz, TP6.

(17) Divider.

U12 divides the 18,4 MHz by 5. The output is 3,68 MHz, TP7.

(18) Loop Filter.

The square-wave from the phasedetector is integrated by R8, C2. U6 is an amplifier-filter removing the 32 kHz from the control voltage to the VCXO. The loop bandwidth is approximately 10 Hz.

19) Divider.

U7 - 8 - 9 divides the input frequency of 5,12 MHz (TP8) by 160. The output at TP3 is a negative pulse with a width of 150nS. The signal is used as input to the phase detector.

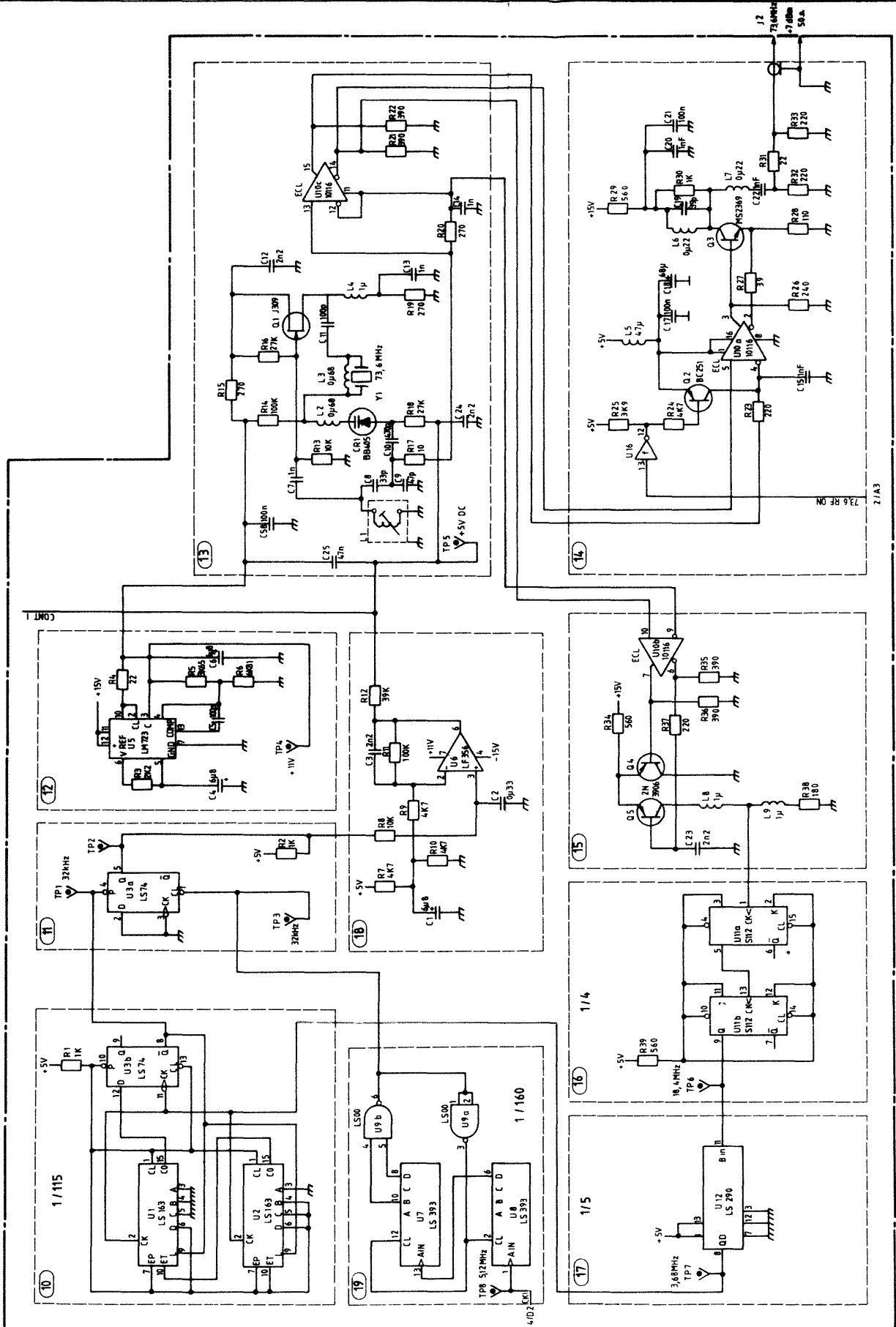

1 2 3 4

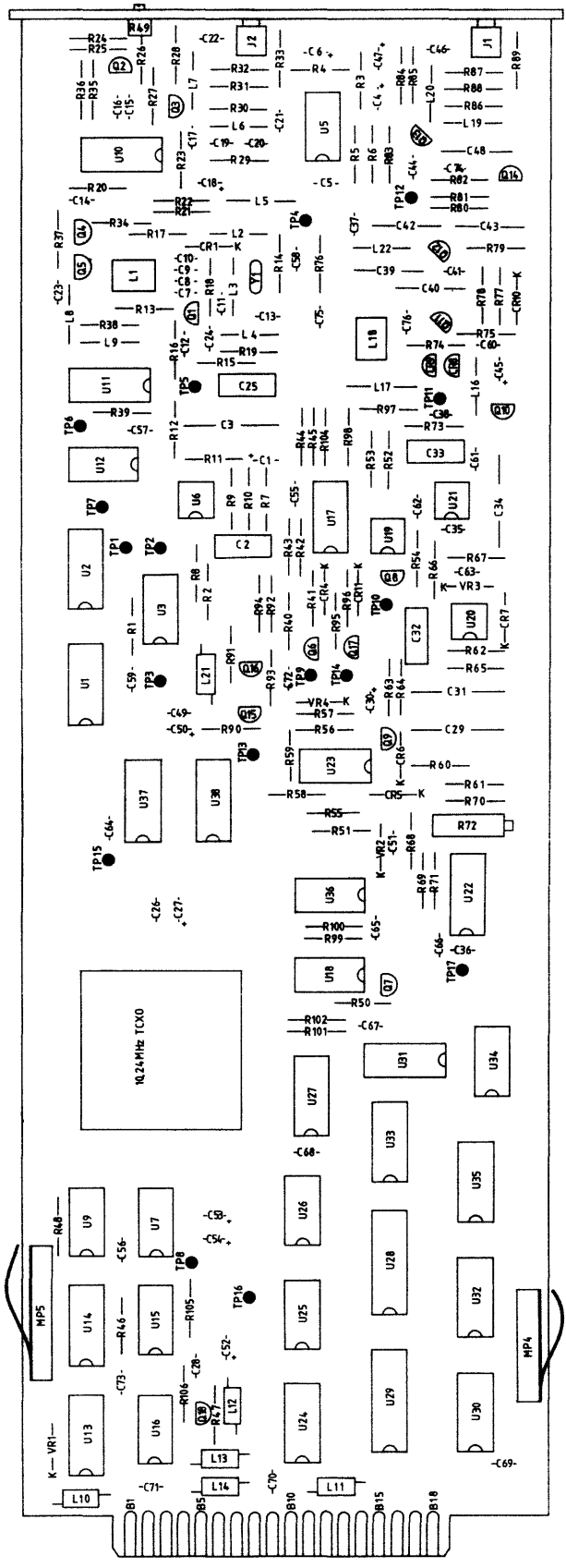

TITLE		FREQUENCY GENERATOR STANDARD	
SIZE	CODE IDENT	DRAWING NO	448184
A1			
SCALE			SHEET 1 OF 1

1 2 3 4

D C B A

(20) Reference Divider.

The buffered Main reference oscillator signal of 10,24 MHz is fed to a divide by 2 (U15a), a divide by 250 performed by U13-14-9d-15b, and a detector Q18, that indicates the presence of the 10,24 MHz. The output from U15b is used as a 40,96 kHz reference signal. The buffered signal from U16d is a negative pulse with a width of approx. 100 nS.

(21) Lockdetector.

The control voltage to the 73,6 MHz VCXO is fed to a window detector 1/2 U17. The loop is within proper conditions when this voltage is between -10V and +9V. Under this condition Q6 gives a HIGH, TP9.

(22) Filter.

Power Supply filter system.

(23) TCXO. Opt.000

Master reference temperature compensated oscillator of 10,240 MHz. R49, frequency fine tuning adjustment.

(23) OCXO. Opt.005

Master reference oven stabilized oscillator of 10,240 MHz. R49, frequency fine adjustment.

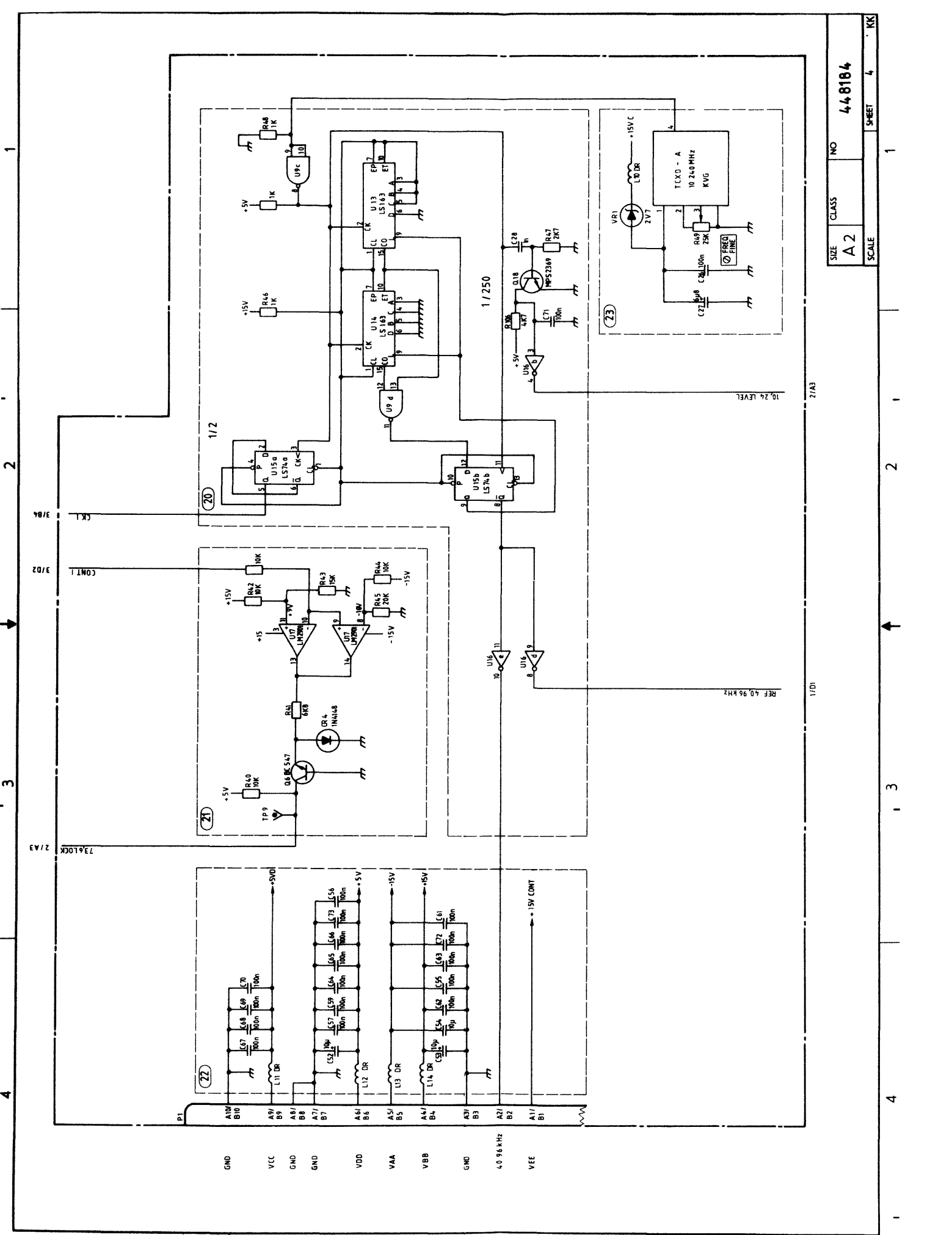

SIZE	CLASS	NO	448184
A2			
SCALE		SHEET	4
			KK

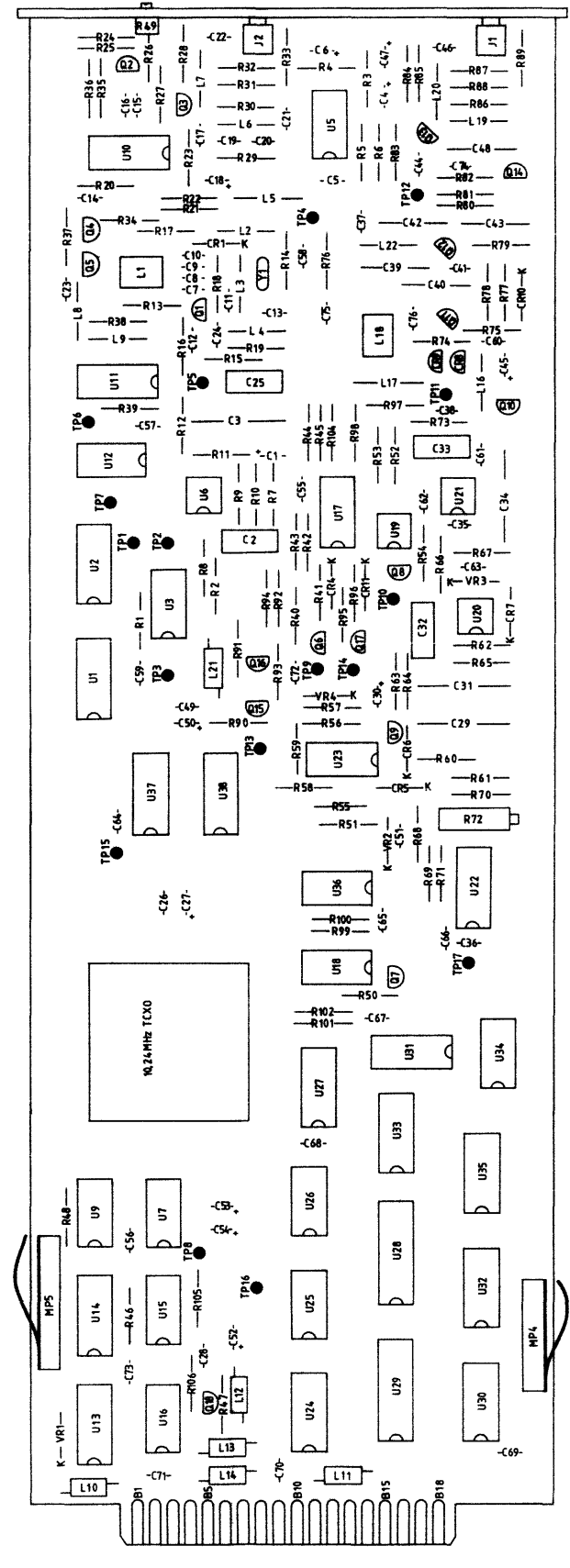

1
2
3
4

1
2
3
4

D
C
B
A

① RF Preamplifier. Gain = +6 dB

② First Mixer. Gain = -6 dB

③ 1.LO Amplifier. Gain = +17 dB

1. 2. 3. 4.

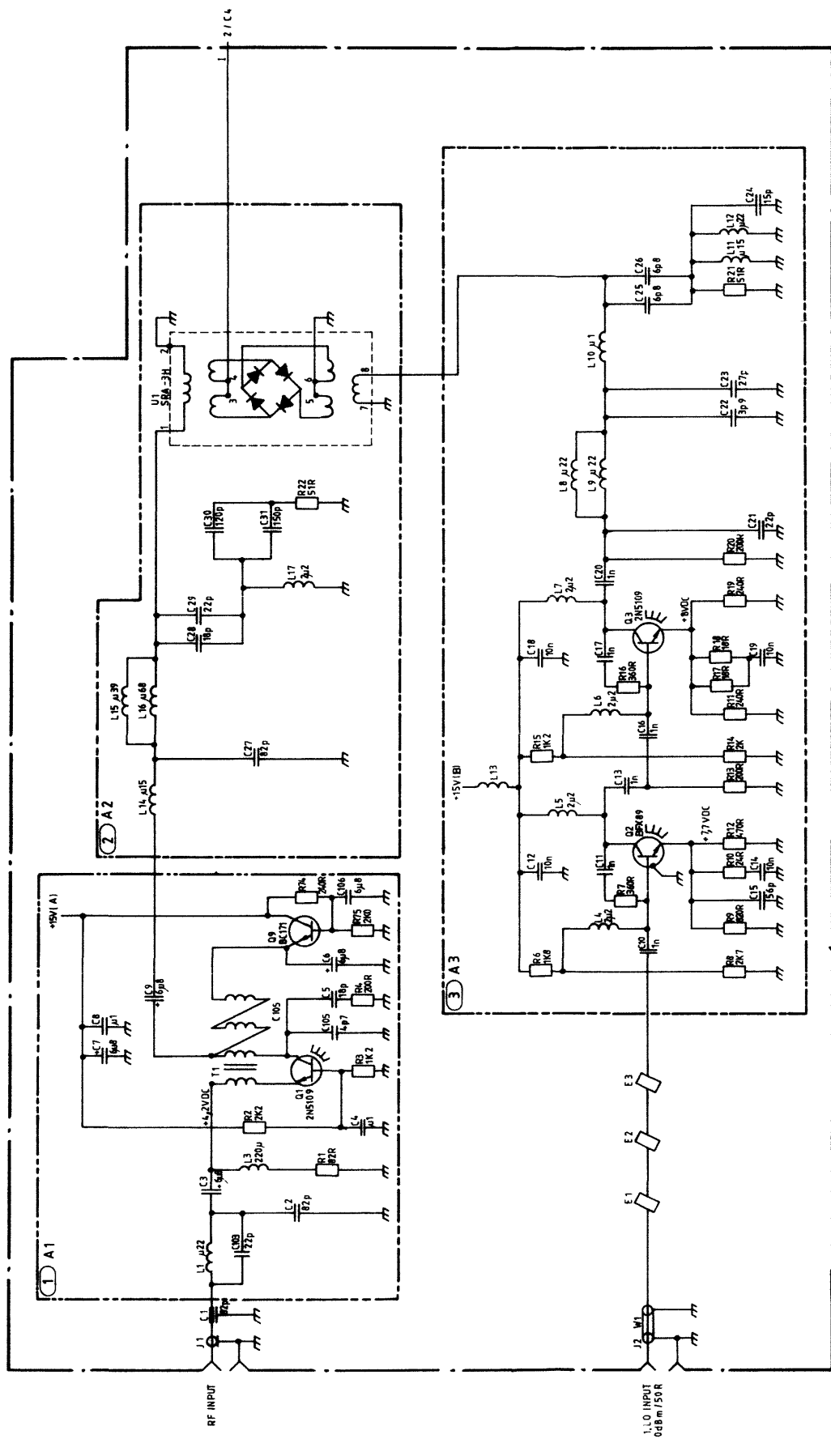

TITLE			
FRONT - END			
SIZE	CLASS	NO	SCALE
A 2		448206	
SHEET 1 OF 4			

1 2 3 4

ON SOLDERING SIDE

C98 L40 C99 C96 C97 L39

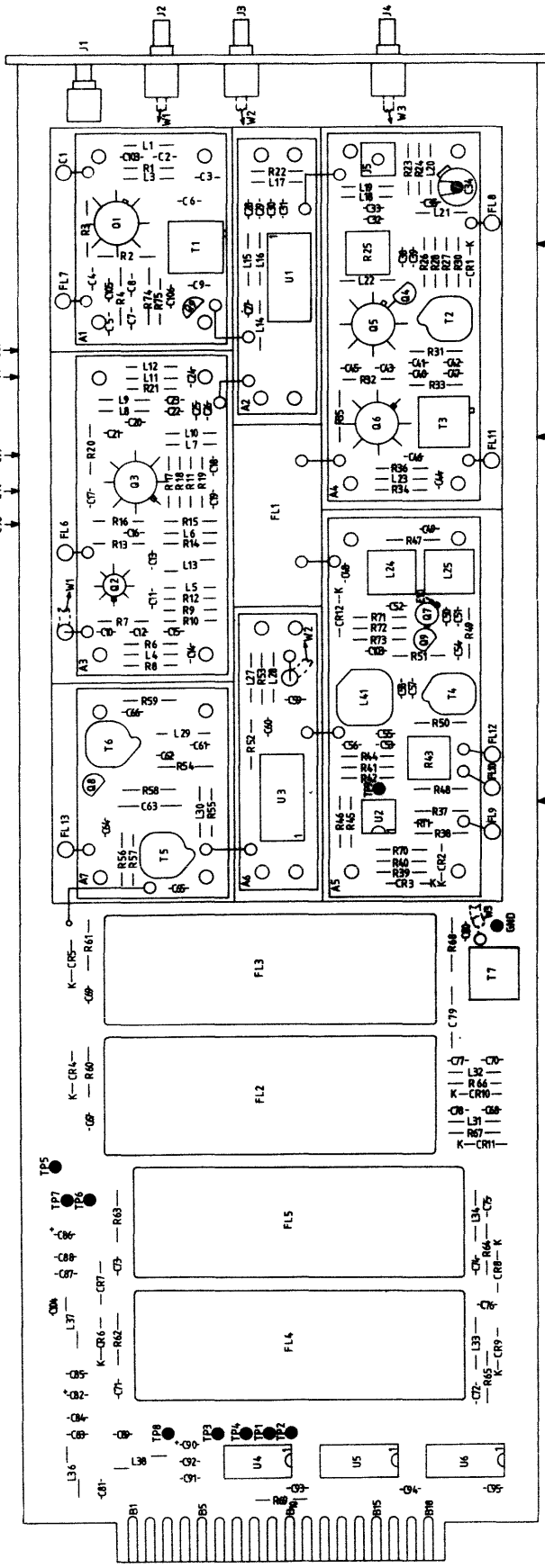

C100 C101 C102 ON SOLDERING SIDE

NOTE
 E1 - E3 MOUNTED ON W1
 E4 - E6 " " " W2
 E7 - E9 " " " W3

TITLE	FRONT - END		
SIZE	A1	CODE IDENT	DRAWING NO 448206
SCALE			SHEET 1 OF 1

1 2 3 4

④ 75 MHz IF Amplifier.

Voltage gain = +14 dB. J5 is only used for factory adjustments.

⑤ 75 MHz X-talfilter. Gain = -4 dB

⑥ 75 MHz Voltage controlled IF Amplifier.

Voltage gain: -41 dB to + 9 dB approx. controlled by the dc-voltage applied to Gate 2 of Q7. C56 to C58 together with L41 form a 72.2 MHz rejection filter.

U2 with surrounding components form an AGC shaping circuit for the AGC voltage AGC1. Offset adjustment (R43): With AGC voltage AGC2 equal to 8V, the attenuation of the IF amplifier is adjusted to maximum minus 2 dB by means of R62 (T-amb. = +25°C). The voltage range of AGC voltage AGC1 is between 0V and +10V.

⑦ Feed-through filter.

1 2 3 4

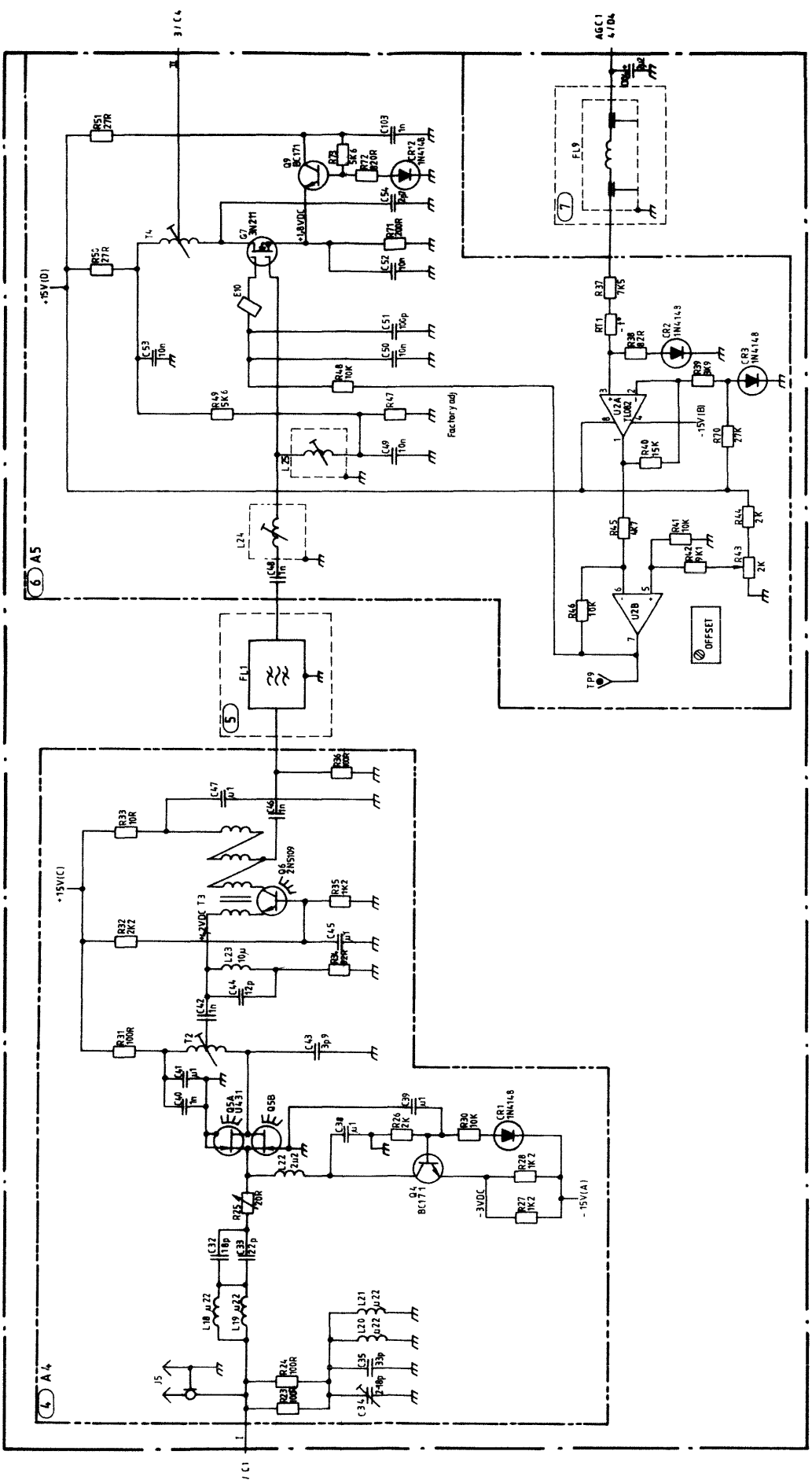

SIZE CODE IDENT NO DRAWING NO
 A2 448206
 SCALE SHEET 2 OF 2

1 2 3 4

ON SOLDERING SIDE

C98 L40 C99 C94 C97 L39

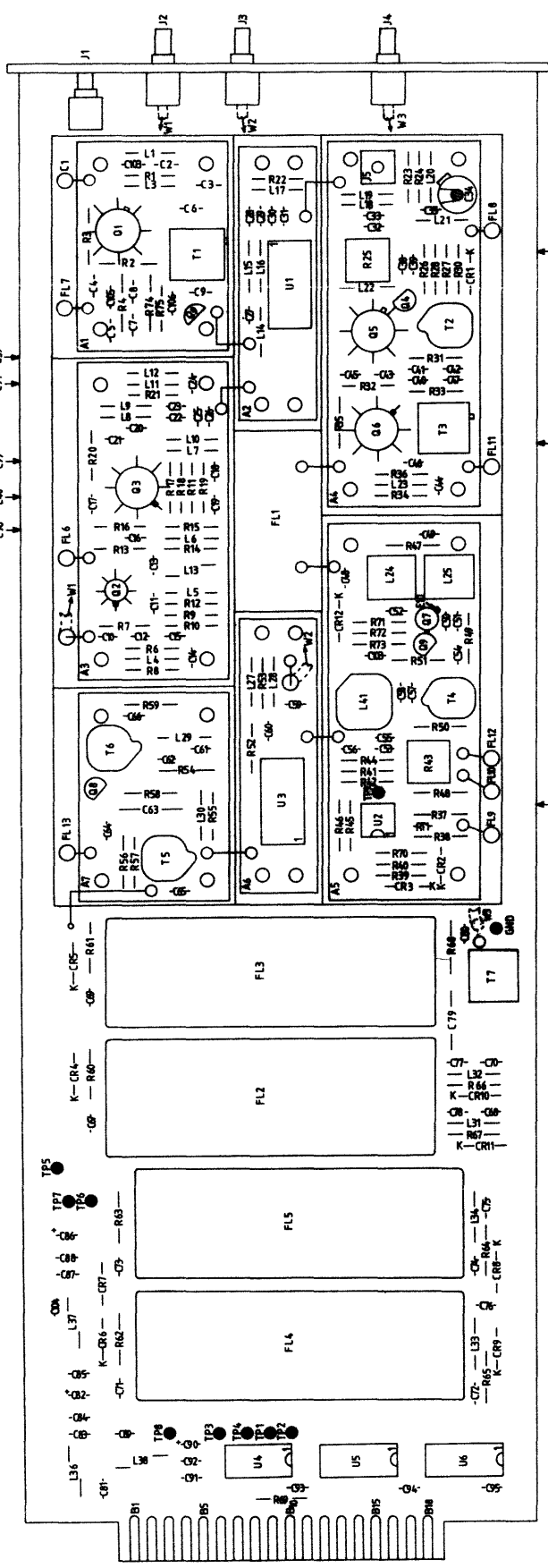

C100

C91

ON SOLDERING SIDE

C102

NOTE
 E1 - E3 MOUNTED ON W1
 E4 - E6 " " " W2
 E7 - E9 " " " W3

TITLE

FRONT - END

SIZE	CODE IDENT	DRAWING NO
A1		448206
SCALE		SHEET 1 OF 1

1 2 3 4

D

C

B

A

8 Second Mixer.

Translates the 75 MHz IF-signal to 1.4 MHz by mixing with 73,6 MHz.
Gain = -6dB.

9 1.4 MHz diplexer and amplifier.

Voltage gain = +23 dB.

10 Information filterbank.

The diodes at the input and at the output of the filters, switch the corresponding X-tal filter on, controlled by the logical level applied to U4. A logical 1 (+5V) switches the filter on.
Voltage gain = -18 dB.

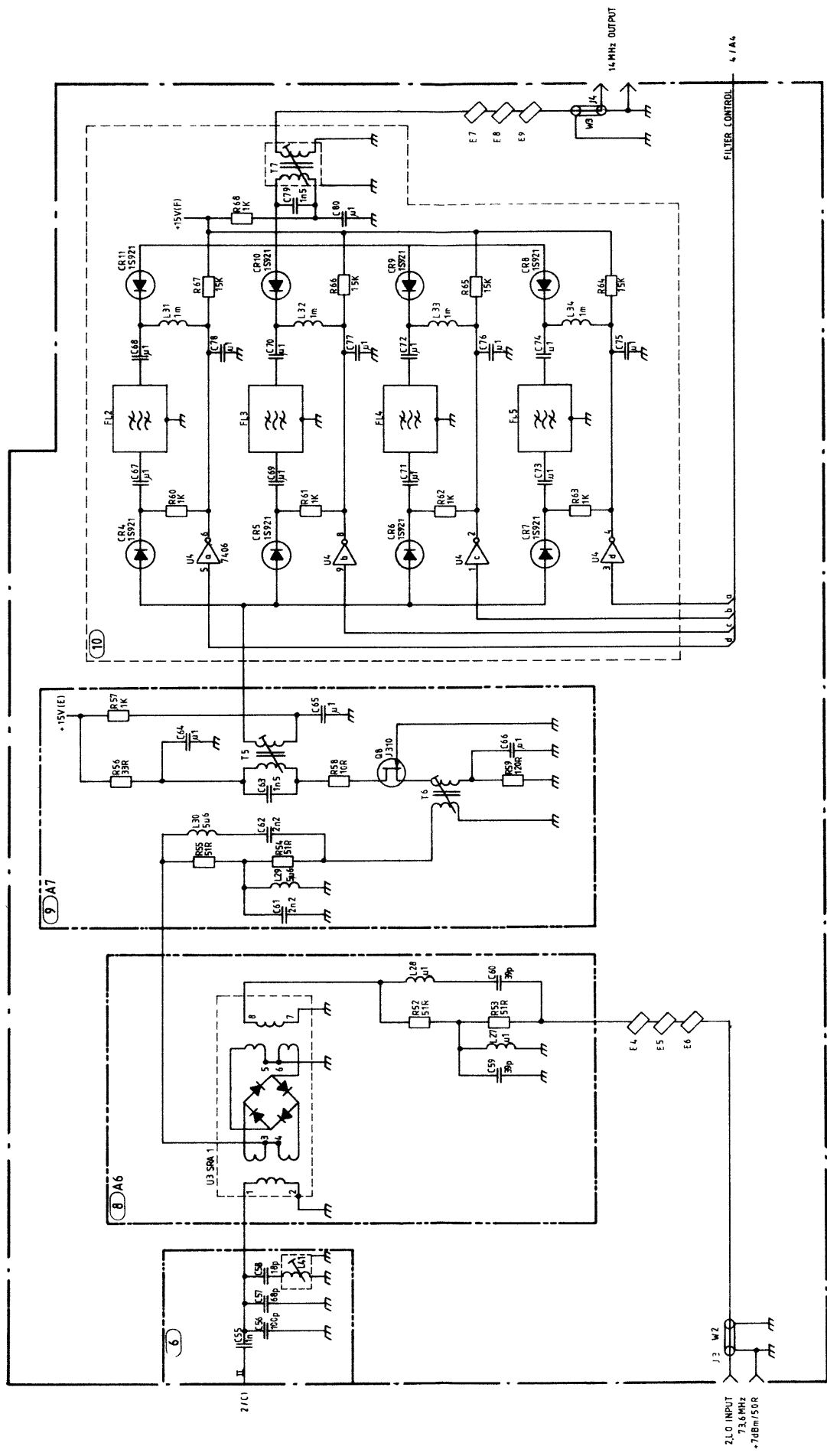

SIZE	CODE IDENT NO	DRAWING NO
A2		448206
SCALE		SHEET 3

1 2 3 4

D C B A

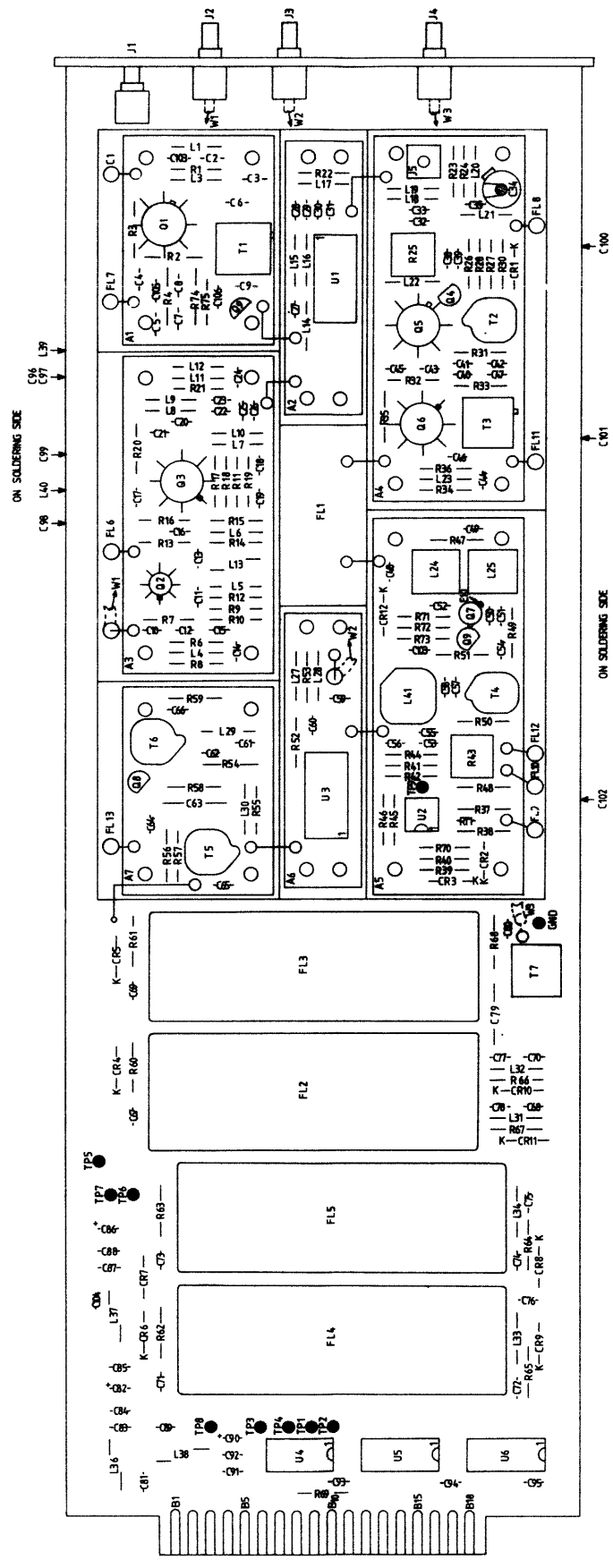

NOTE
 E1 - E3 MOUNTED ON W1
 E4 - E6 " " " W2
 E7 - E9 " " " W3

TITLE		FRONT - END
SIZE	CODE IDENT	DRAWING NO
A1		448206
SCALE	SHEET 1 OF 1	

1 2 3 4

1) Filtering circuit for bias voltages.

2) Microcomputer interface circuit.

The address of the module is FF26.

When the five least significant address bits are applied to the assembly in inverted form, output U5-5 follows \overline{WR} . On a positive transition of \overline{WR} , data is loaded into U6 and appears at the Q-outputs. \overline{TTACK} (A11) follows \overline{WR} provided that the correct address is present.

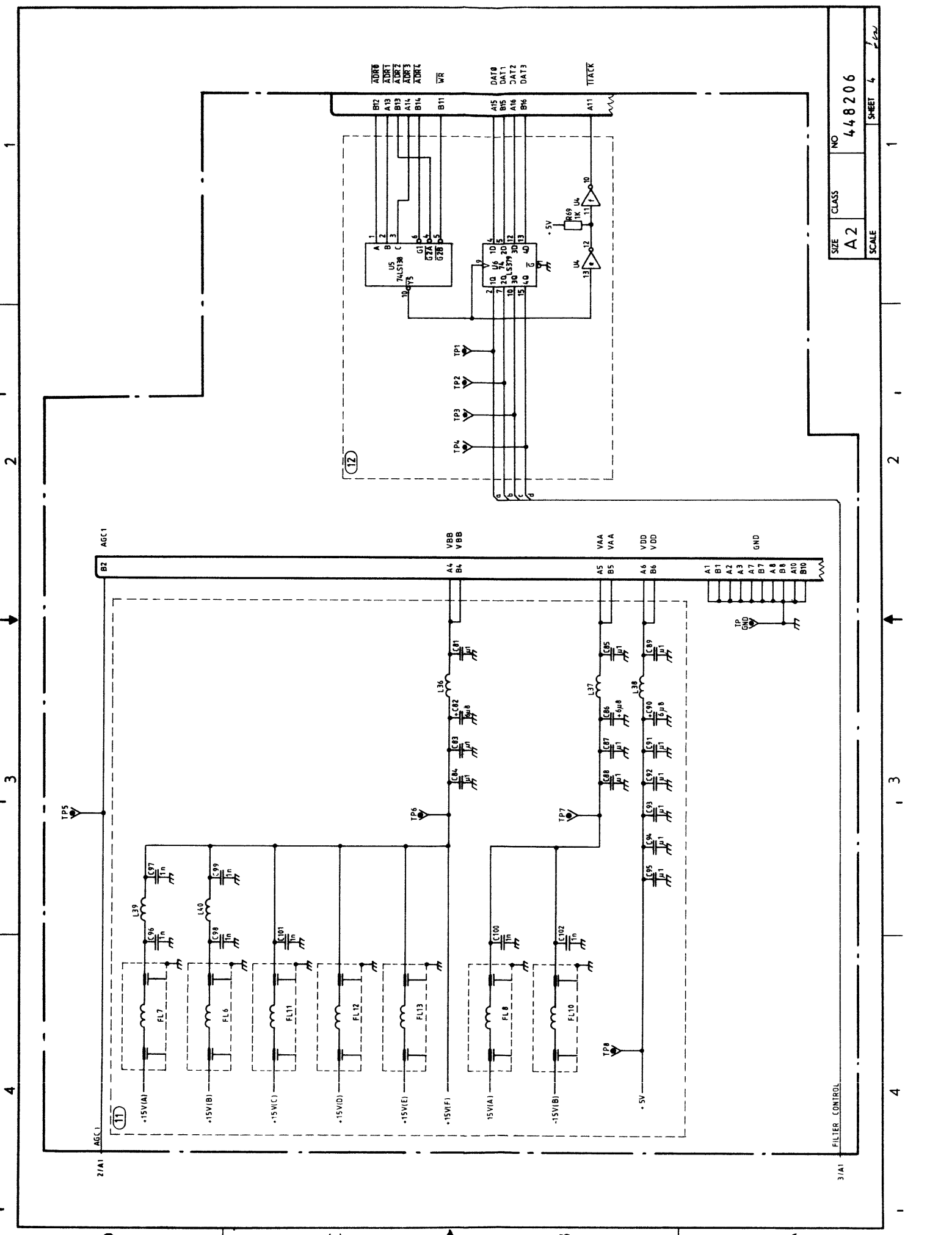

SIZE	CLASS	NO	448206
A2			
SCALE		SHEET	4

1 2 3 4

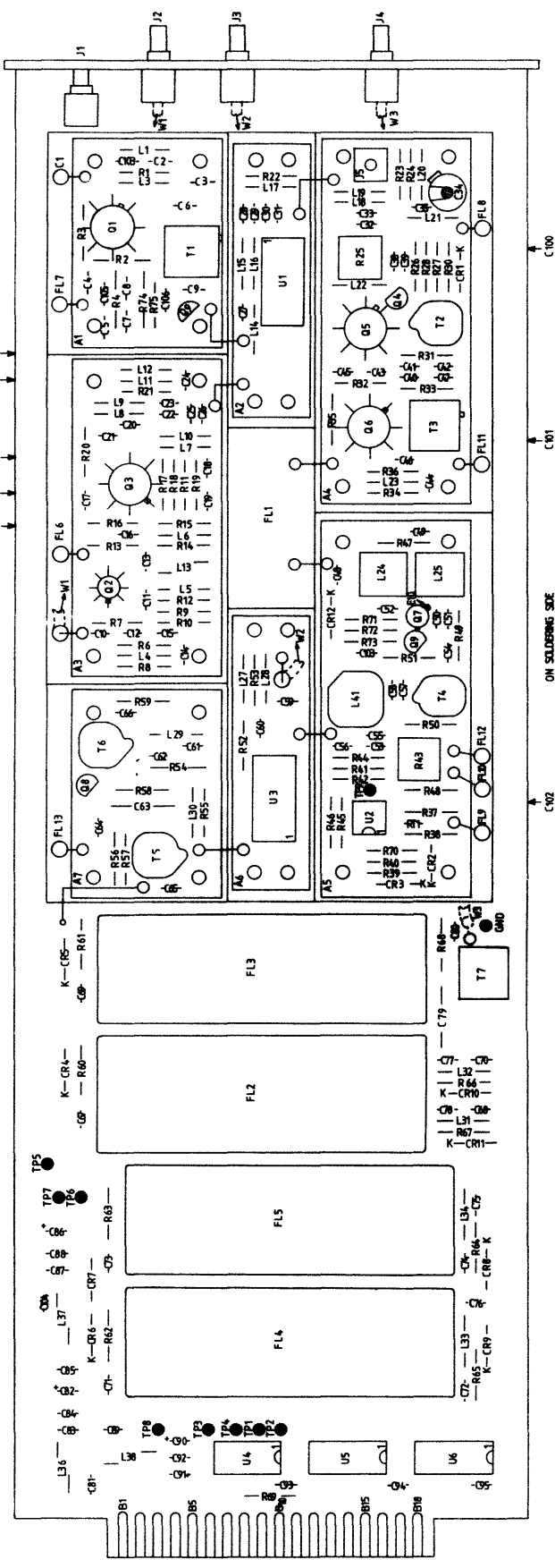

NOTE
 E1 - E3 MOUNTED ON W1
 E4 - E6 " " W2
 E7 - E9 " " W3

TITLE		FRONT - END	
SIZE	CODE IDENT	DRAWING NO	
A1		4 4 8 2 0 6	
SCALE		SHEET 1 OF 1	

1 2 3 4

D C B A

1 Bus Interface.

When the correct address is present, the output of U1 follows the write input pulses, thereby clocking datawords from the bus to the outputs of U2.

U3 and U4 form a 1 out of 16 decoder with open collector outputs.

The signals "MUTE", "RNGØ" and "RNGF" are not used.

2 Relay circuit.

A range is selected by applying a "0" to one of the wires 1 to E.

All relays are SPSTNO.

3 Supply line filters.

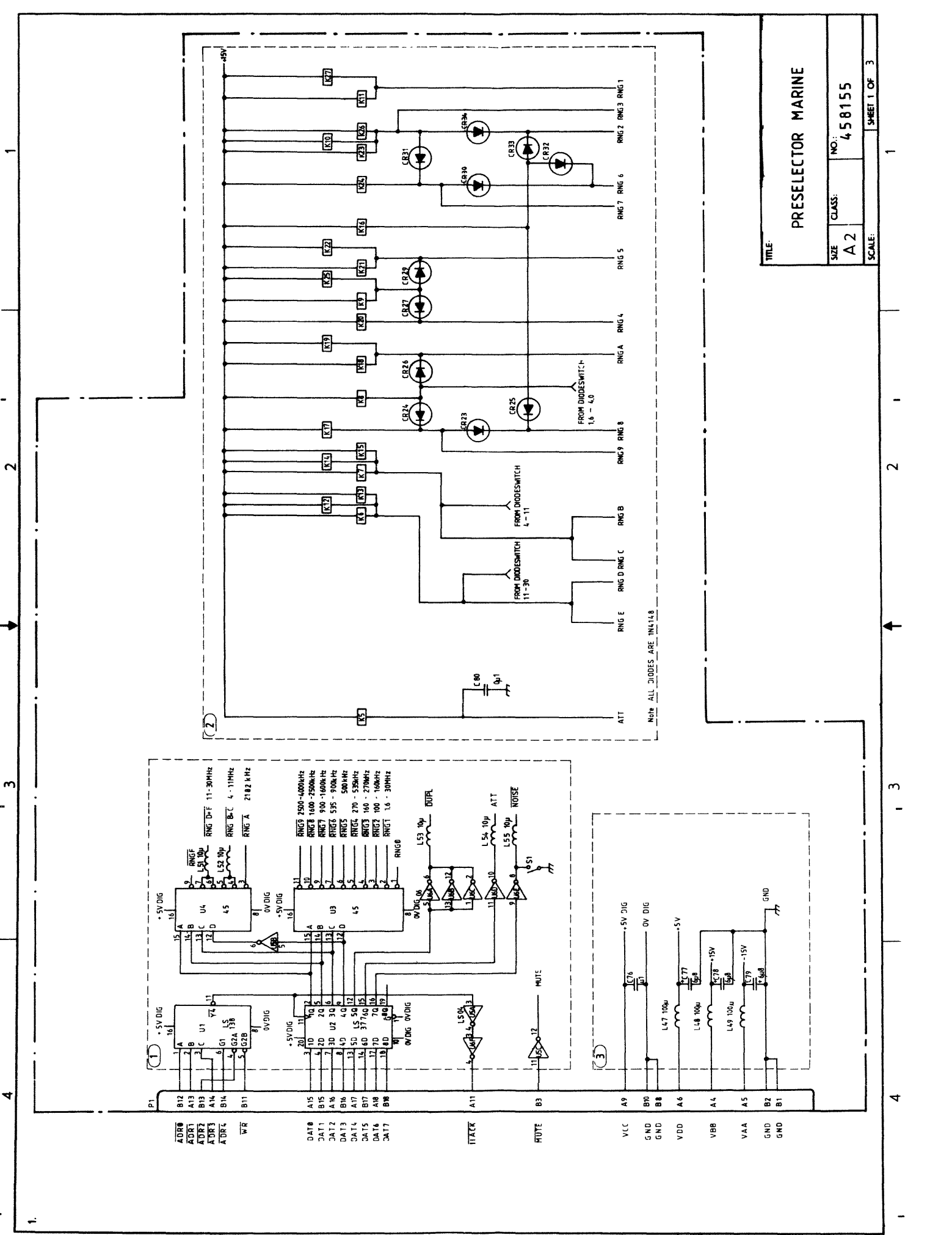

TITLE: PRESELECTOR MARINE	
SIZE: A2	NO.: 458155
CLASS:	SCALE:
SHEET 1 OF 3	

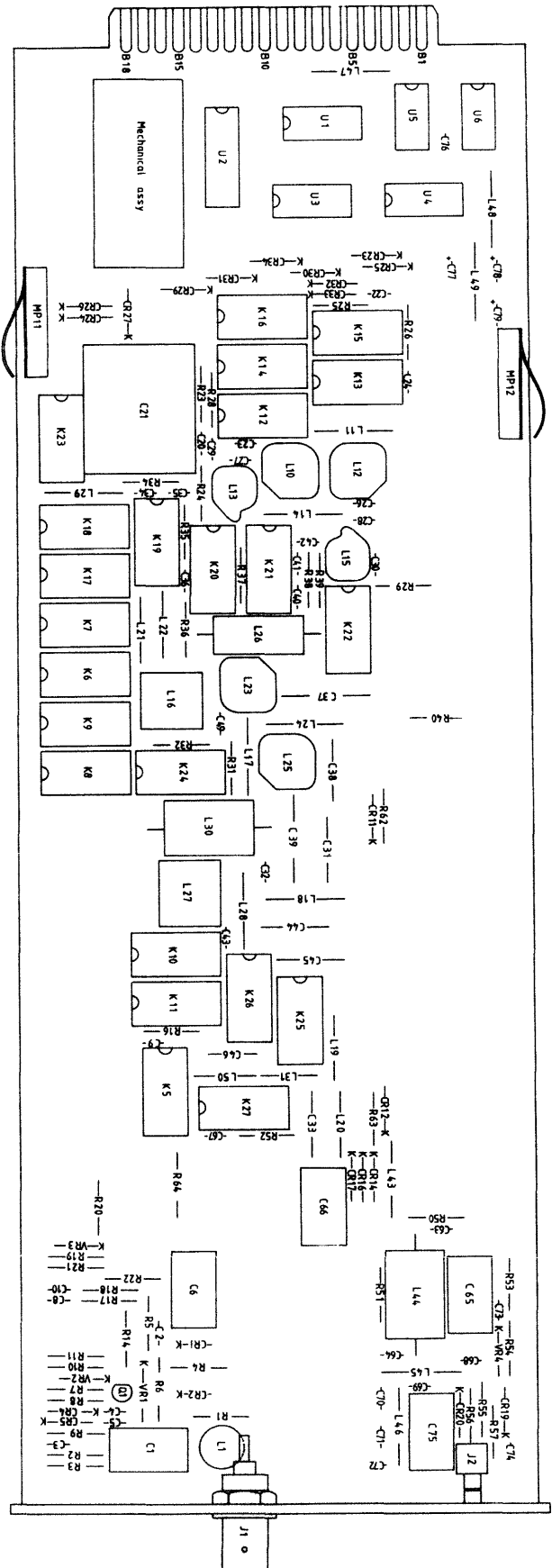

TITLE

PRESELECTOR, MARINE

SIZE CODE IDENT DRAWING NO
A1 458155

SCALE SHEET 1 OF 1

④ Input protection clipper.

The output signal at C6 is limited to 10Vpp by CR1 and CR2.

⑤ Input protection detector.

At frequencies above 5 MHz Q1 will conduct when the RF voltage at C1 exceeds 10 Vpp, thereby lowering the bias voltage at CR1 and CR2. This tends to make the clipping level frequency independent, as CR4 and CR5 are fast switching diodes.

⑥ Duplex filters 4, 6 and 8 MHz.

Opt.003

The series circuits are tuned to the center of the shipsTx duplex bands.

⑦ Duplex filters 12, 16, 22 and 25MHz.

Opt.003

When the duplex mode is selected in these bands, K1 is opened while K3 and K4 are closed.

The series circuits are tuned to the center of the ships Tx duplex bands.

The tuning of L8 and L9 shall be at equal positions.

⑧ Noise generator.

When a "0" is applied to R22 the zener diode VR3 is reverse biased through R19.

The noise output is coupled through R20 and C9 to the receiver input line.

⑨ Input attenuator. (20 dB)

⑩ 11-30 MHz BP- filter.

⑪ 4-11 MHz BP filter.

K16 is closed in the ranges 100-160 kHz, 535-900 kHz and 1.6-2.5 MHz to parallel the sections of C21.

⑫ 1.6-2.5 MHz, 2.5-4.0 MHz and 2182 kHz.

The antenna reactance is tuned out by L21 (or L22 at 2182 kHz) in series with C21 while the antenna resistance is terminated through the broadband transformer L16.

L17, C31 and L18 form a 1.6 MHz HP filter.

L19, C33 and L20 form a 4 MHz LP filter.

At 2182 kHz K17 is open and K18, K19 are closed.

⑬ 270-535 kHz and 500 kHz.

The antenna reactance is tuned out by L26 in series with C21 and the antenna resistance is terminated through the fixed BP filter formed by L23-L25 and C37-C39.

At 500 kHz K21 and K22 are closed and K20 is open.

⑭ 100-160 kHz, 160-270 kHz, 535-900 kHz and 900-1600 kHz.

At 100-270 kHz K23 is closed.

At 535-1600 kHz K23 and K24 are closed.

C44, L28 and C45 form a 1.6 MHz LP filter.

⑮ Wideband 1.6-30 MHz.

L31, C46 and L50 form a 1.6 MHz HP filter.

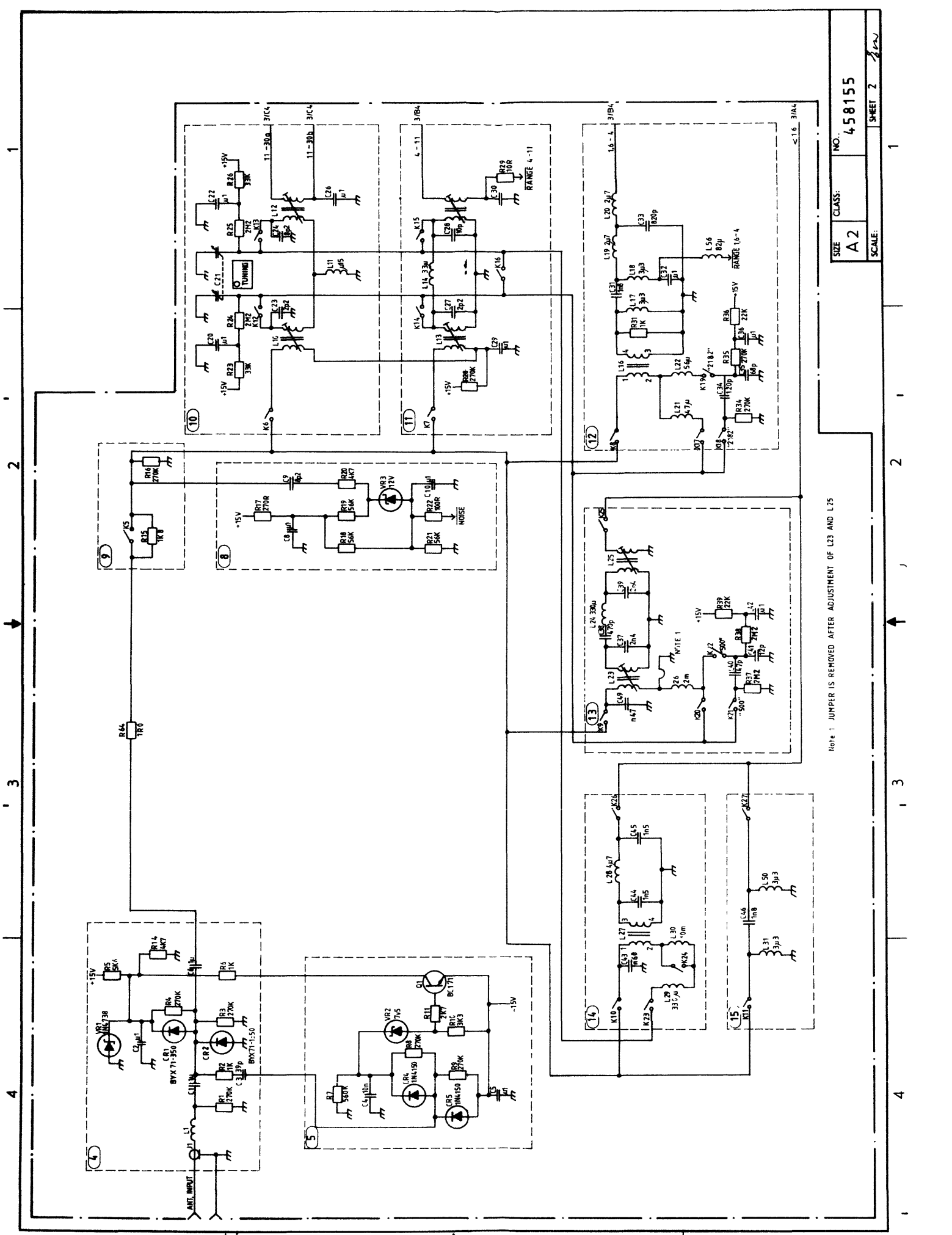

Note 1 JUMPER IS REMOVED AFTER ADJUSTMENT OF L23 AND L25

SIZE	CLASS	NO.
A2		458155
SCALE:		SHEET 2

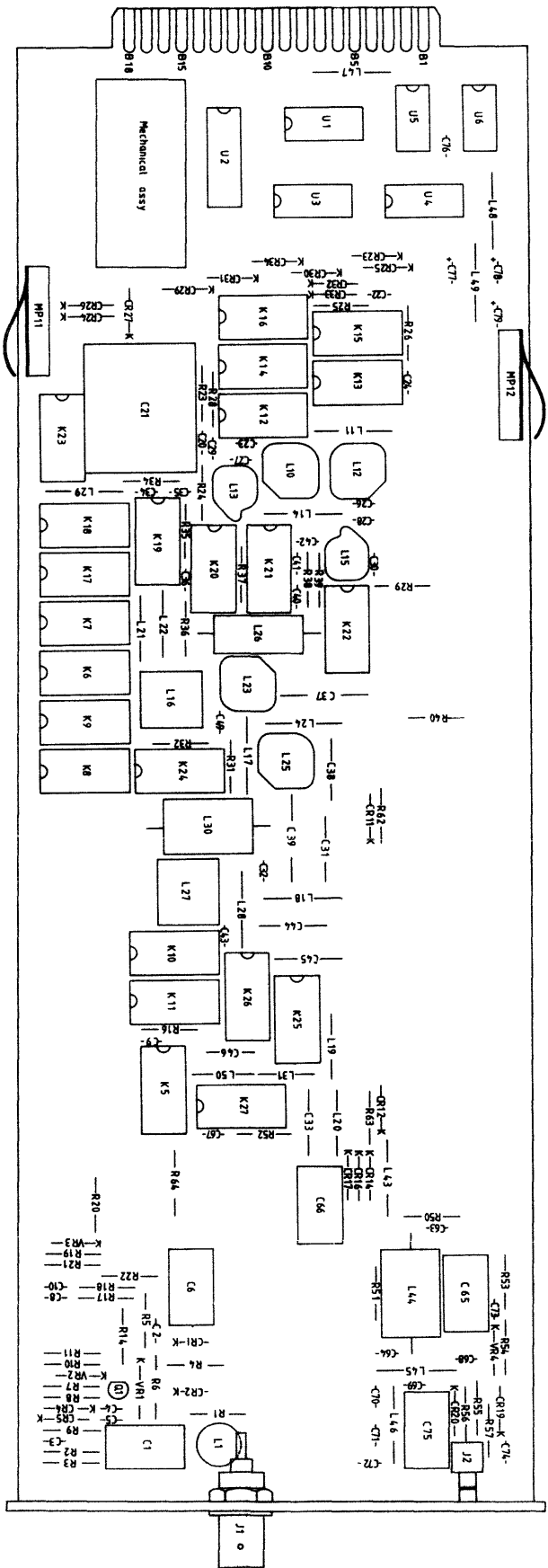

TITLE
PRESELECTOR, MARINE

SIZE CODE IDENT DRAWING NO
 A1 458155

SCALE SHEET 1 OF 1

A B C D

1 2 3 4

(16) Switch control circuit.

pt.003 CR8, CR9 and Q2 are turned on when duplex mode is selected. R40 is grounded through CR8 thus preventing current from flowing to CR11 and CR12.

Through R47, CR15 is turned on.

Through R43, CR10 and CR13 are turned on when 11-30 MHz and duplex mode are selected.

When 11-30 MHz and simplex mode are selected, CR11 and CR12 are turned on through R40 while CR10 and CR13 are reverse biased through R44.

(17) Duplex filters 12, 16, 22 and 25 MHz.

Opt.003 In simplex mode CR11 and CR12 are on.

In duplex mode CR10 and CR13 are on.

The series circuits are tuned to the center of the ships Tx duplex bands.

The tuning cores of L36 and L37 shall be at equal positions.

(18) Diode switches.

CR14 is on at 11-30 MHz.

CR16 is on at 4-11 MHz.

CR17 is on at 1.6-2.5 MHz and 2.5-4.0 MHz.

A 10V reverse bias is applied to the diodes not used.

(19) Duplex filters 4, 6, 8 MHz.

In duplex mode CR15 is on.

The series circuits are tuned to the center of the ships Tx duplex bands.

(20) 30 MHz LP filter.

(21) Relay contact bias circuit.

(22) Output protection circuit.

The output at C75 is limited to 6Vpp.

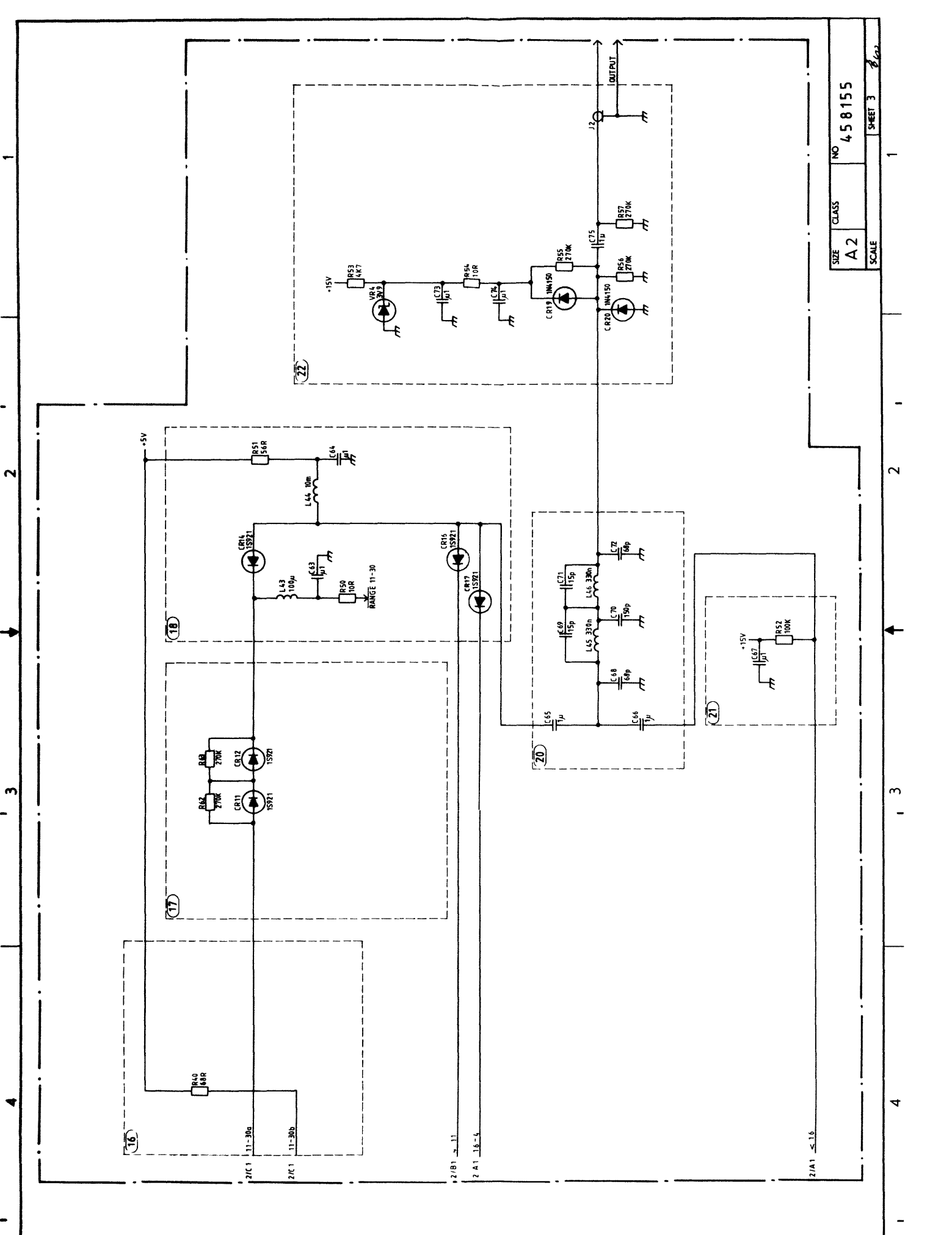

SIZE	CLASS	NO	458155
A2			
SCALE		SHEET	3

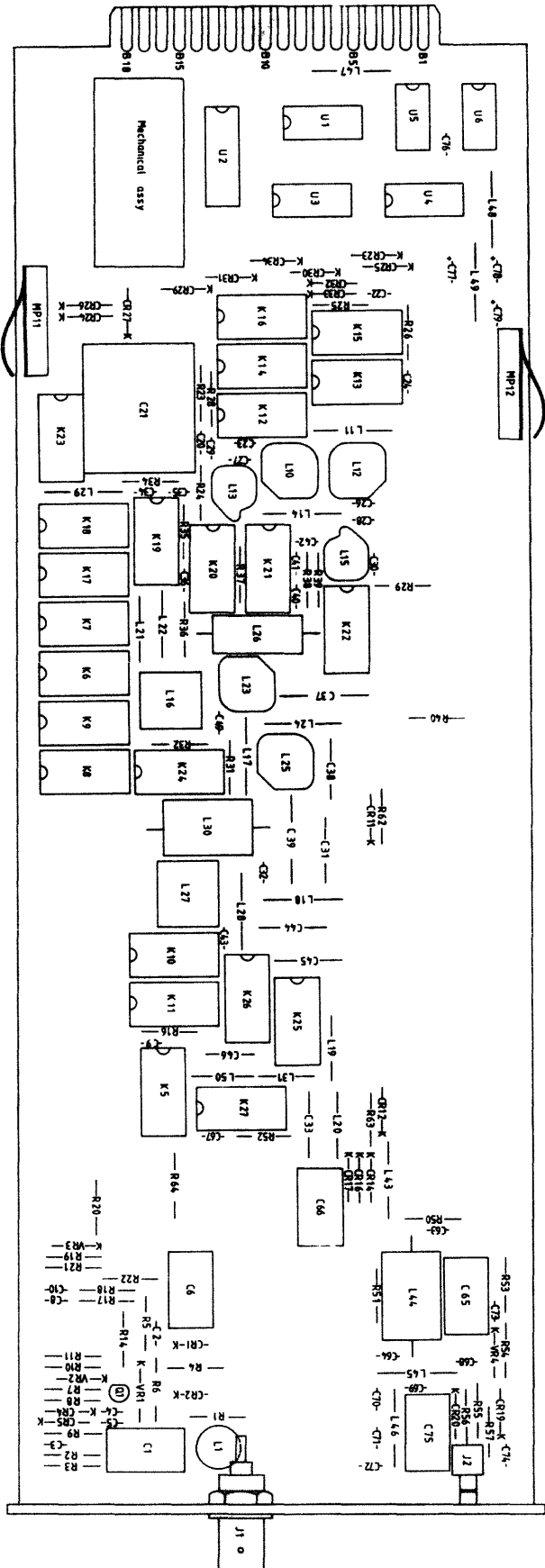

TITLE		PRESELECTOR, MARINE	
SIZE	CODE IDENT	DRAWING NO	
A1		430155	
SCALE	SHEET 1 OF 1		

A B C D

1 2 3 4

1 2

1

1

- ① 1.4 MHz tuned amplifier
Voltage gain: +25 dB approx.
- ② 1.4 MHz Voltage controlled tuned amplifier.
Voltage gain: -40 dB to +50 dB approx. Controlled by the current through R5.
- ③ Dc-amplifier for AGC-voltage (AGC 2).
Offset adjustment (R62): With AGC-voltage AGC 2 equal to 0V the gain reduction of U1 (block 2) is adjusted to 1 dB by means of R62 (T-amb. = 24°C). The voltage range of the AGC-voltage AGC 2 is between 0V and +10V.
- ④ 1.4 MHz adjustable tuned amplifier.
Gain adjustment (R11): A 1.4 MHz/ -107 dBm signal is applied to J1, IF-input. The signal IF-output, J2, is monitored. The adjustment in ③ is carried out first, then the signal at W2 is adjusted to -20 dBm/50Ω (63mV/ 50Ω) by means of R11.
- ⑤ Buffer amplifier for IF-output signal.
- ⑥ Logarithmic AGC-detector.
The AGC attack level is adjustable by means of R109. When the IF-output level is -20 dBm/50 ohms, the nominal dc voltage at TP9 is 0V.
- ⑦ 1.4 MHz signal splitting amplifier.

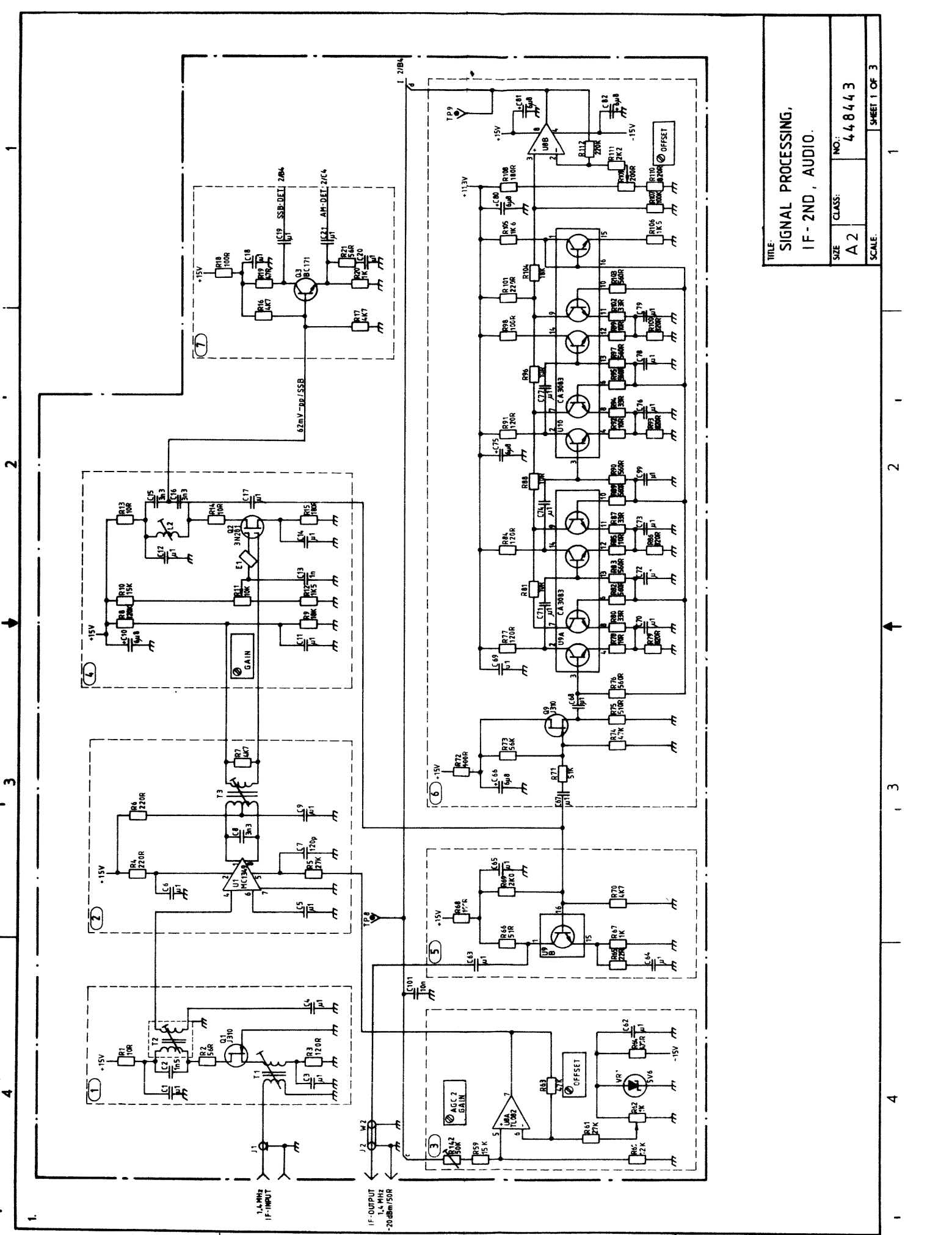

TITLE:		SIGNAL PROCESSING, IF-2ND, AUDIO.	
SIZE	CLASS:	NO.:	448443
A2			
SCALE:		SHEET 1 OF 3	

1 2 3 4

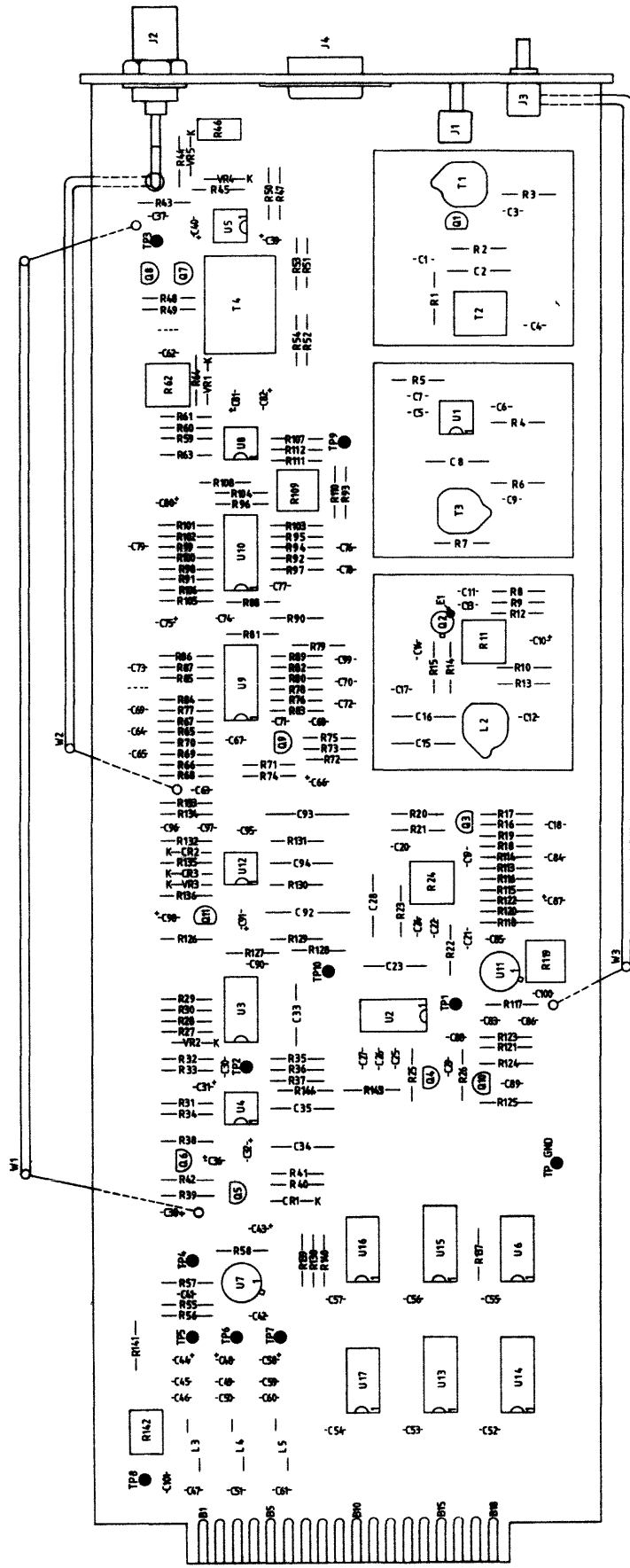

TITLE		SIGNAL PROCESSING, IF - 2ND, AUDIO	
SIZE	A1	CODE IDENT	DRAWING NO. 44 B 4 4 3
SCALE		SHEET 1 OF 1	

1 2 3 4

D C T B A

⑧ Synchronous AM-detector.

The detector gain is adjustable by means of R24. Nominal AF-voltage at TP 3 is 100 mV-rms (280 mV-pp) when the AM-signal is modulated to 50%/ 1 kHz.

⑨ DC-voltage switch for block 8.

A logical 1 applied to U6a-3 switches the dc-voltage on. The switch is on in mode AM, only.

⑩ Balanced SSB/CW Demodulator.

The demodulator gain is adjustable by means of R119. Nominal AF-voltage at TP 3 is 100 mV-rms (280 mV-pp) @ 1 kHz.

⑪ DC-voltage switch for ⑩

A logical 1 applied to U6e-5 switches the dc-voltage on. The switch is on in modes SSB and CW, only.

⑫ Mode selection switch.

The relationship between the selected mode and the logic levels at the control inputs are as follows:

Mode	Control input		
	U3-13	U3-5	U3-12,6
AM	1	0	0
SSB,RTTY	0	1	0
CW/Wide, inter	0	1	0
CW/vnar, navr.	0	0	1

A logical 1 correspond to +12V

A logical 0 correspond to 0V

⑬ 1.4 kHz LP-filter.

The filter is inserted after the Demodulator in modes CW/vnar. and CW/narr.

⑭ LF-amplifier. Voltage gain:30dB.

Nominal voltage level at TP2:115mV-rms (322mV-pp).

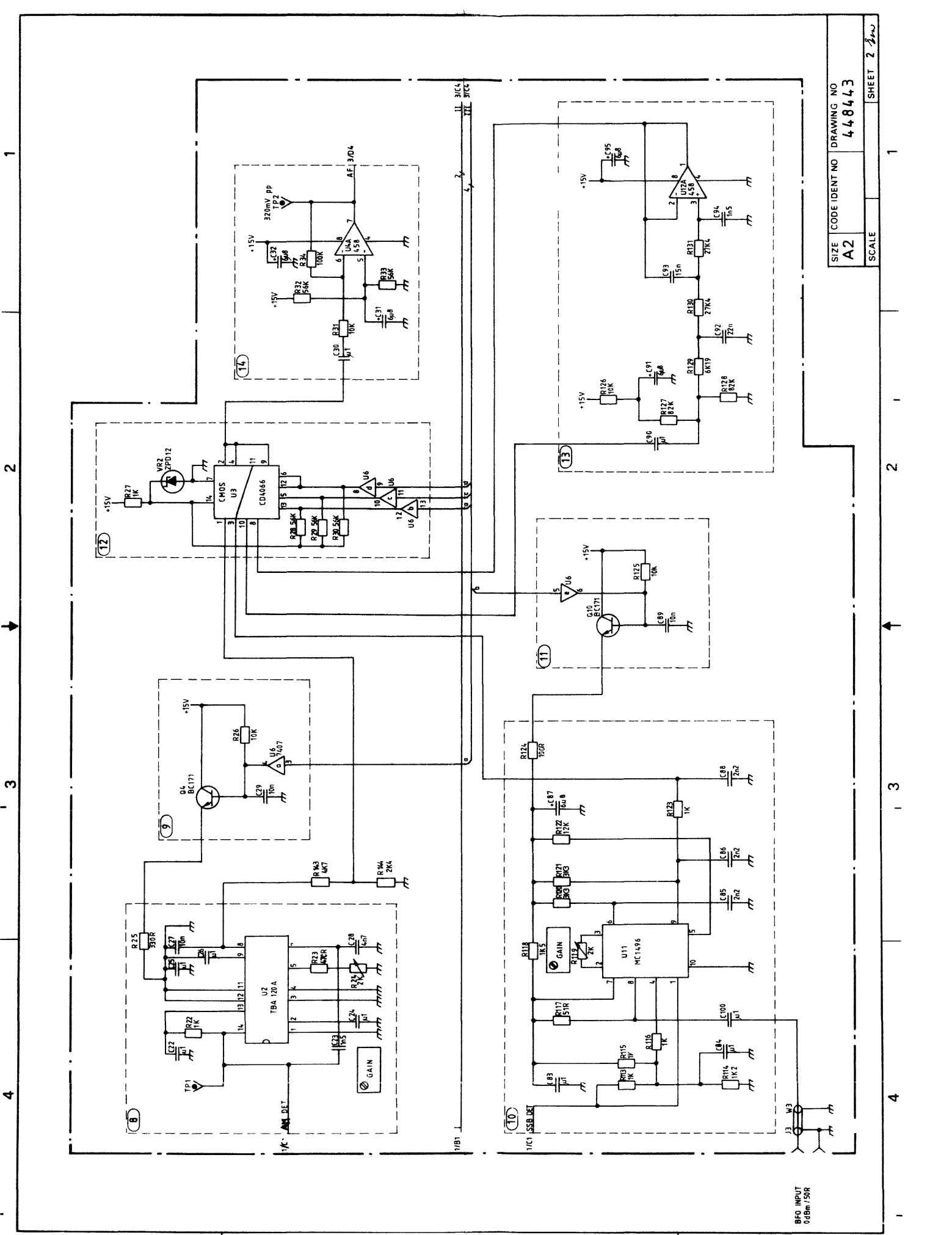

SIZE CODE IDENT NO DRAWING NO
A2 448443
 SCALE SHEET 2 of 2

1
2
3
4

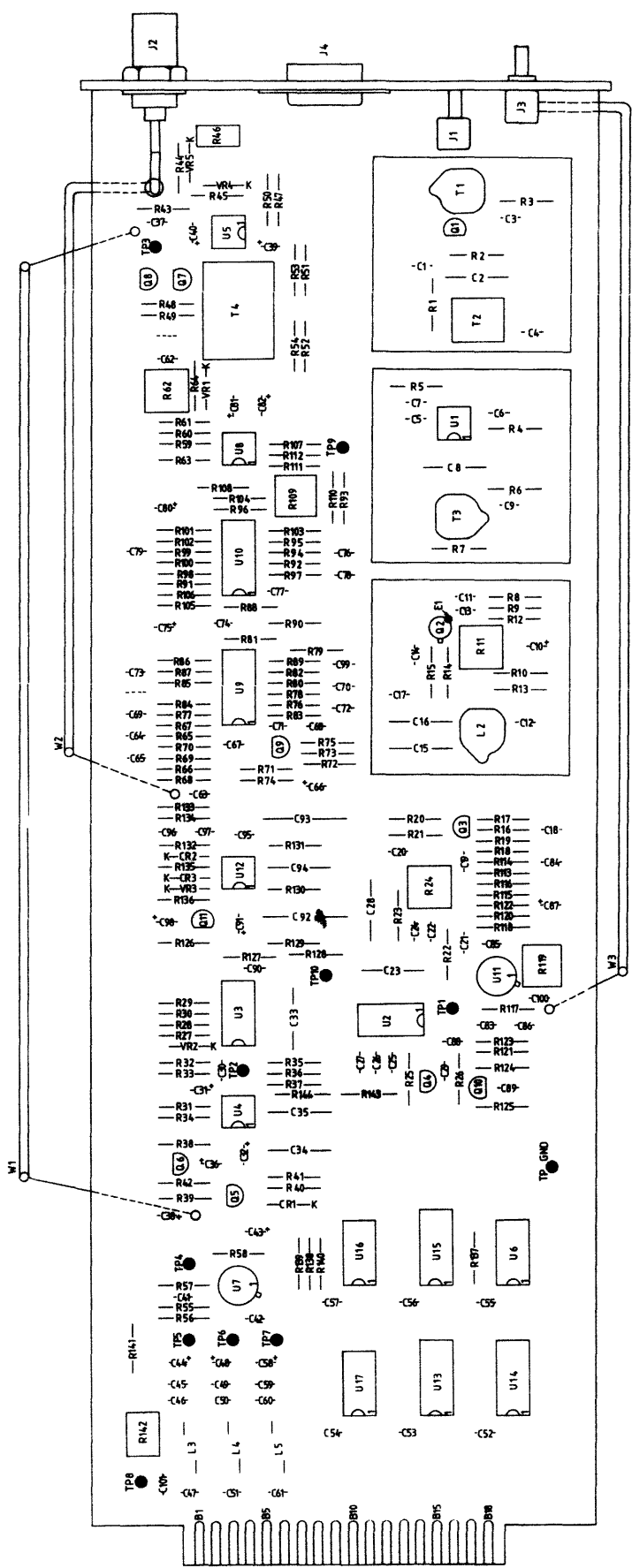

TITLE	SIGNAL PROCESSING, IF - 2ND, AUDIO
SIZE	CODE IDENT DRAWING NO A1 44 84 4 3
SCALE	
SHEET	1 OF 1

1
2
3
4

D C B A

(15) 4 kHz LP-filter.

(16) Muting circuit.

A logical 1 applied to U6f-1 forces Q5 on, thus short circuiting the signal path.

(17) Signal Detector.

When a signal is present in the signal path a logic 0 appears at TP10.

(18) Line Amplifier.

Output level up to +10 dBm/ 600 Ω adjustable by means of R46 which is accessible through a hole in the rear panel. Nominal voltage level at TP3: 100mV-rms (280 mV-pp).

(19) 11.3V Voltage Regulator for the AGC-detector circuit. Voltage tolerance: +/- 0.7 V

(20) Filtering circuit for bias voltages.

(21) Microcomputer interface circuit.

The address of the assembly is FF29. When the five least significant address bits are applied to the module in inverted form, U13-9 goes low. This enables U14 and U15. On a positive transition of \overline{WR} , data is loaded into U14 and appears at the Q-outputs. A logical 0 at \overline{RD} en-

ables three-state buffer U15, provided that U15-15 is at logical 0. Thus data at input U15-2 is fed to connector P1- - A15 (DAT 0). \overline{ATACK} (A11) goes low when \overline{RD} or \overline{WR} goes low provided that the correct address is present.

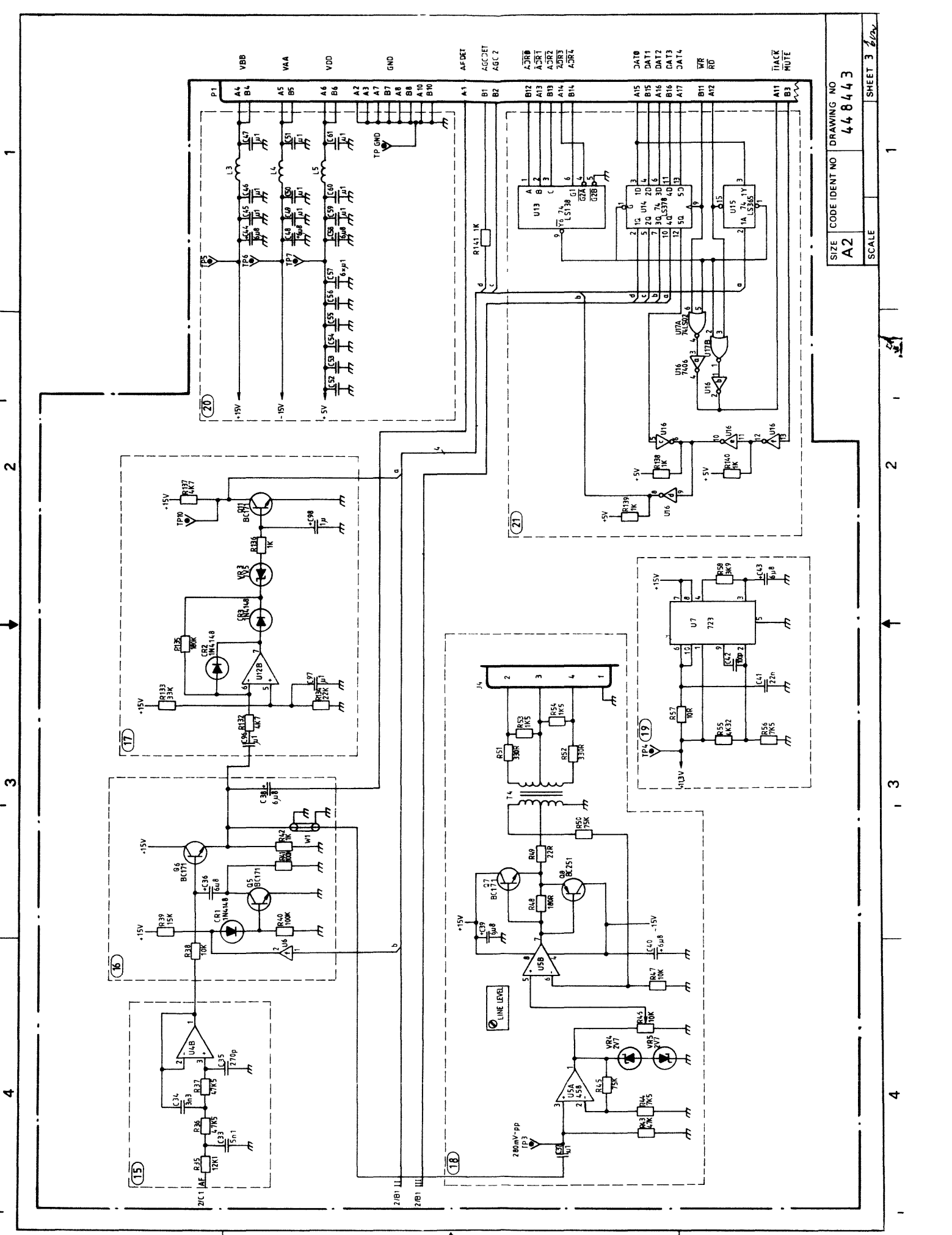

SIZE	CODE IDENT NO	DRAWING NO
A2		448443
SCALE		SHEET 3 of 3

1 2 3 4

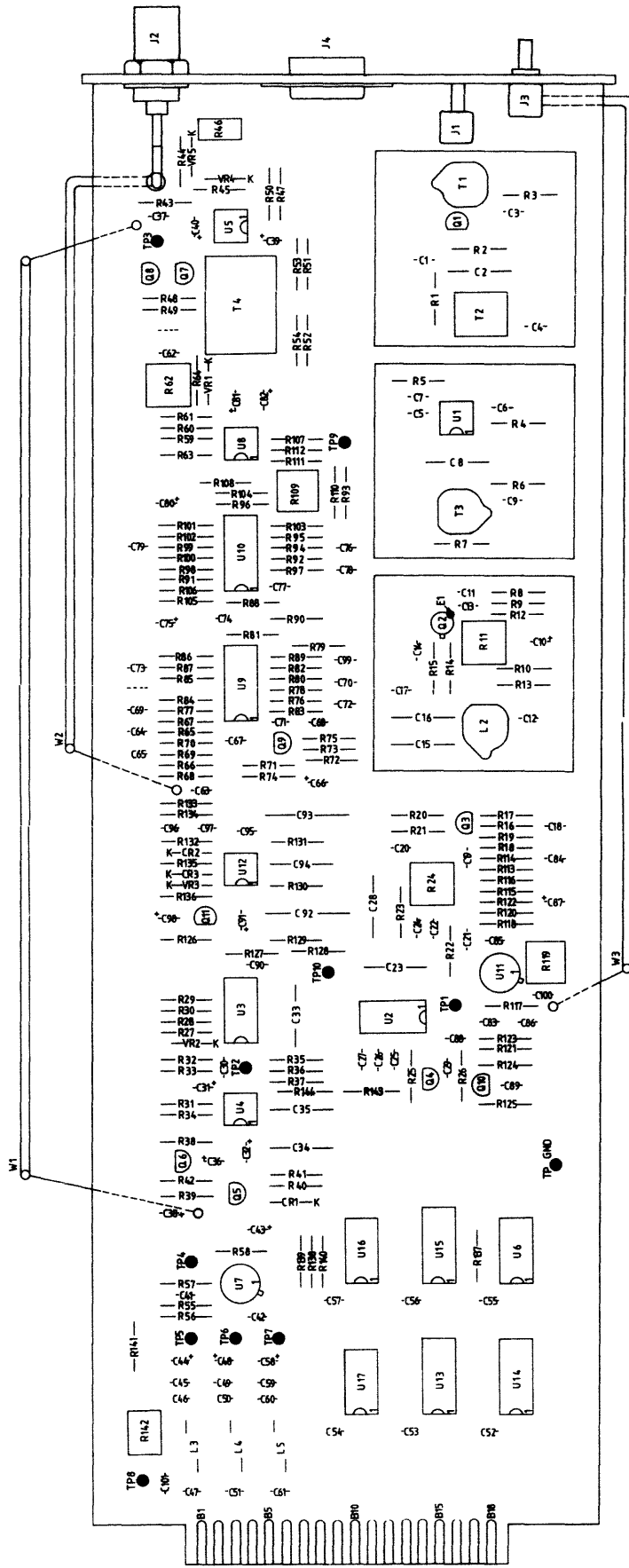

D C B A

TITLE	SIGNAL PROCESSING, IF - 2ND, AUDIO		
SIZE	CODE IDENT	DRAWING NO	448443
A1			
SCALE			SHEET 1 OF 1

1 2 3 4

① U1: 8085 microprocessor with associated 6.144 MHz crystal for internal clockstabilisation.

U12: Eight-bit latch for multiplexing address line DB0-DB7.

U13: Buffer for command signals etc.

② Watch-dog for surveillance of correct start-up and system software operation.

At system start-up R4, C1 ensures that a reset pulse of approx. 10 msec is generated. This pulse is routed to the microprocessor through U2.

U2: Retrigger astable multivibrator with a period of 1 s. Under normal operation, the software ensures that U2 is retriggered at appropriate intervals so that the reset signal to the microprocessor is disabled. Appearance of software error causes the retrigger to cease and reset pulse generation will start-up.

③ Timer that starts counting when $\overline{\text{OFF}}\overline{\text{BD}}\overline{\text{REQ}}$ goes low.

If the timer counts out, no acknowledge-signal has been received within the last 16 ms, and a Trap-interrupt is generated to the microprocessor.

In normal operation, acknowledge-signals should be received within 16 ms.

④ Network that converts an acknowledge-signal to a ready-signal to the microprocessor.

⑤ The flip/flop U14 delays the start of $\overline{\text{WR}}$ -signal one half of a CLK-period, which ensures that BUFEN-signal delays the enable of buffer U17 in accordance with the timing.

$\overline{\text{OFF}}\overline{\text{BD}}\overline{\text{REQ}}$ and $\overline{\text{OFF}}\overline{\text{BD}}\overline{\text{WR}}$ are only generated if no acknowledge-signal on board has been received before start of BUFEN.

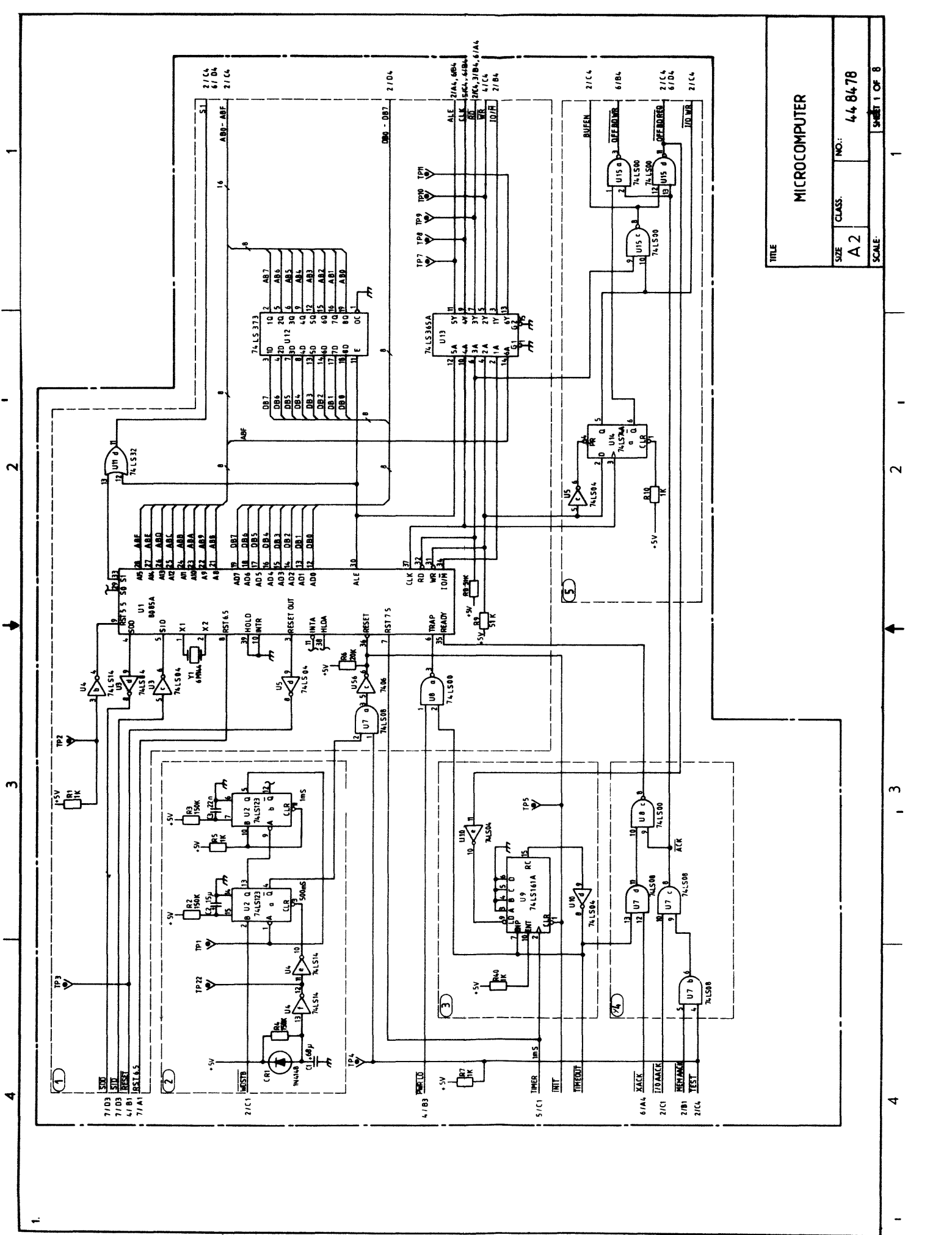

TITLE		MICROCOMPUTER	
SIZE	CLASS.	NO.:	44 8478
A 2		SCALE:	SHEET 1 OF 8

1 2 3 4

D C B A

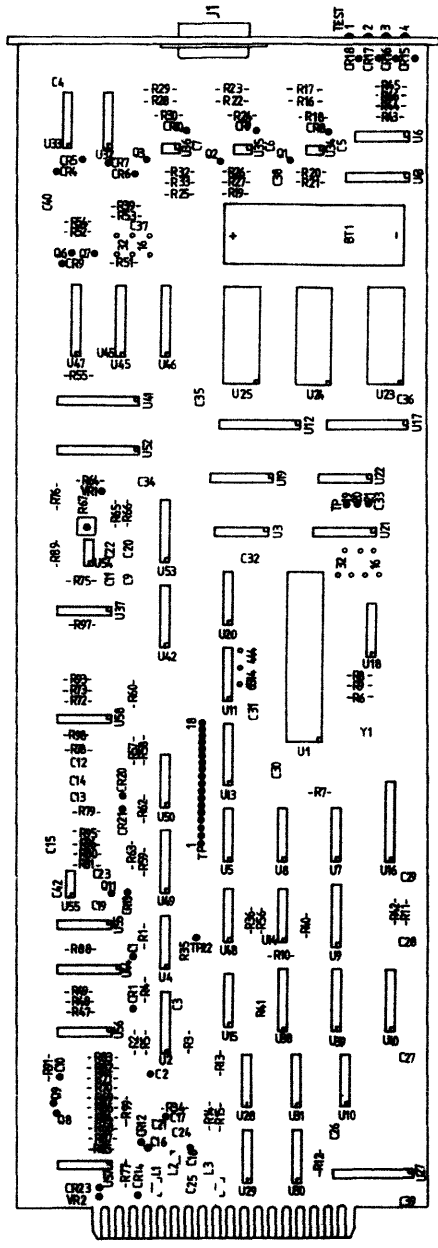

0.1

TITLE		MICROCOMPUTER	
SIZE	A 2	CODE IDENT	DRAWING NO. 4,8478
SCALE		SHEET 1 OF 1	

1 2 3 4

⑥ U16: Eight-bit buffer which is enabled during "free-running" i.e. when $\overline{\text{TEST}}$ is low. When "free-running" is selected U16 forces the microprocessor to read NOP-instructions, regardless of the microprocessor address.

⑦ U17: Eight-bit bidirectional data bus buffer, which is enabled during on board operations.

⑧ Address decoding for generating on board chip selects for I/O operations. An acknowledge-signal $\overline{\text{I/O}}\overline{\text{AA}}\overline{\text{CK}}$ is generated for every I/O-address, as a handshaking signal to the microprocessor.

⑨ Address decoding for generating on board chip selects for memory operations. An acknowledge-signal $\overline{\text{MEM}}\overline{\text{AA}}\overline{\text{CK}}$ is generated for every memory-address as handshaking signal to the microprocessor.

The "2716" and "2732" links determine the address range of $\overline{\text{CS1}}$, $\overline{\text{CS2}}$ and $\overline{\text{CS3}}$.

	2716	2732
	addr. range	addr. range
$\overline{\text{CS1}}$	0-7FFH	0-FFFH
$\overline{\text{CS2}}$	800H-FFFH	1000H-1FFFH
$\overline{\text{CS3}}$	1000H-17FFH	2000H-2FFFH

The HM-6514-9 and microprocessor D444 links are set in accordance with the type of CMOS-RAM (U47) fitted. The links provide the correct timing for the type of CMOS-RAM fitted.

1 2 3 4

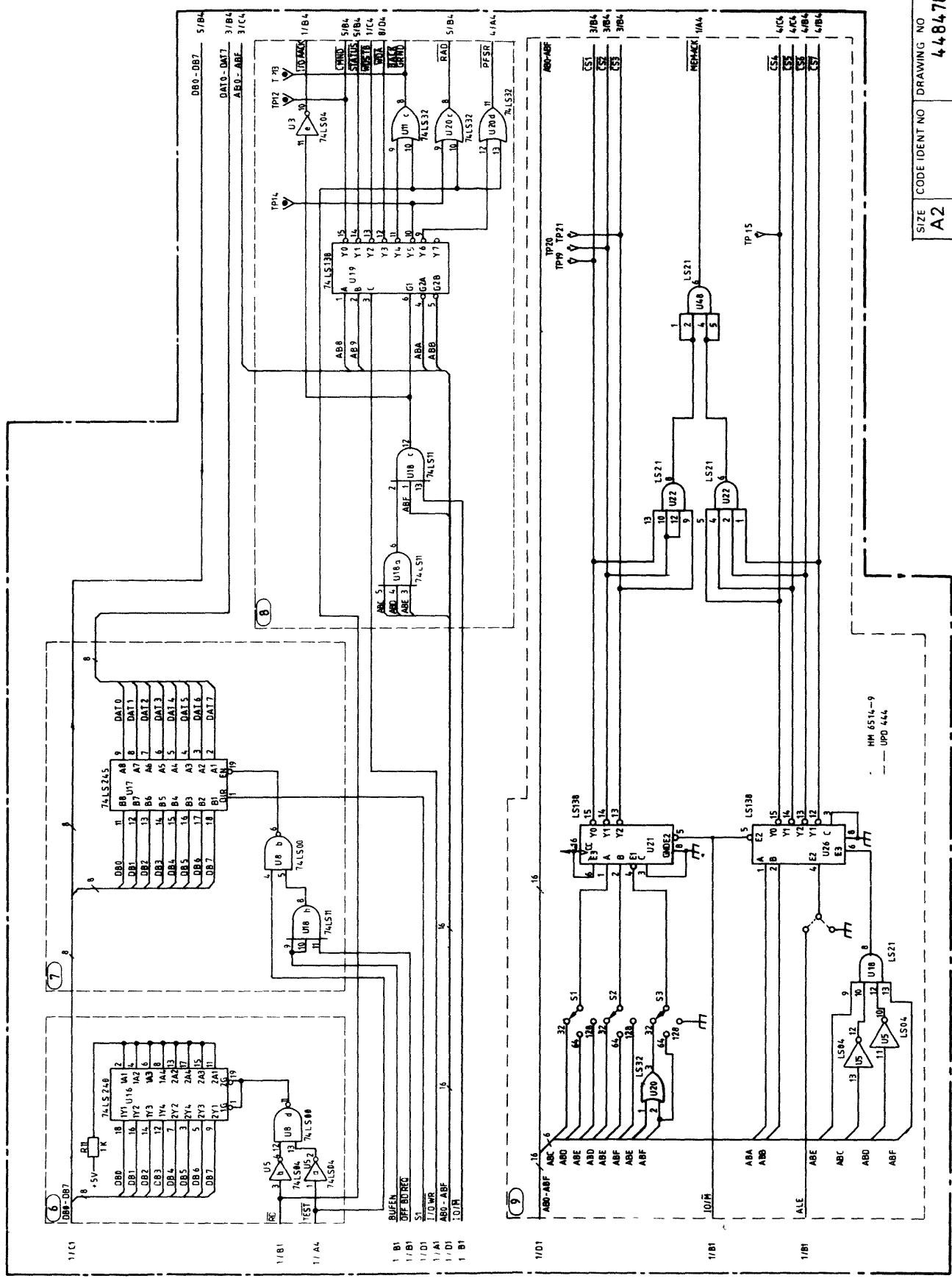

SIZE	CODE IDENT NO	DRAWING NO
A2		448478
SCALE		SHEET 2 KK

1 2 3 4

D C B A

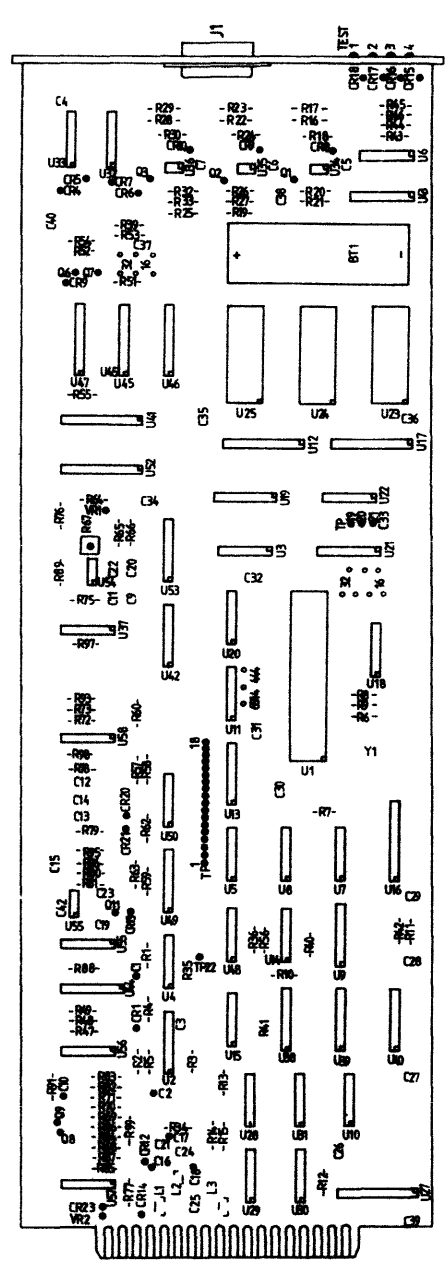

0 1 2 3 4

TITLE		MICROCOMPUTER	
SIZE	CODE IDENT	DRAWING NO.	
A 2		448478	
SCALE		SHEET 1 OF 1	

1 2 3 4

⑩ PROM-area.

Links	U23	U24	U25
16.16	2716	2716	2716
16.32	2716	2716	2732
32.16	2732	2732	2716
32.32	2732	2732	2732

The content of 2716 is 2K x 8 bit

The content of 2732 is 4K x 8 bit

The linking has to be in accordance with the address-decoding ⑨

The individual PROM's are selected by activation of the corresponding power-down control line.

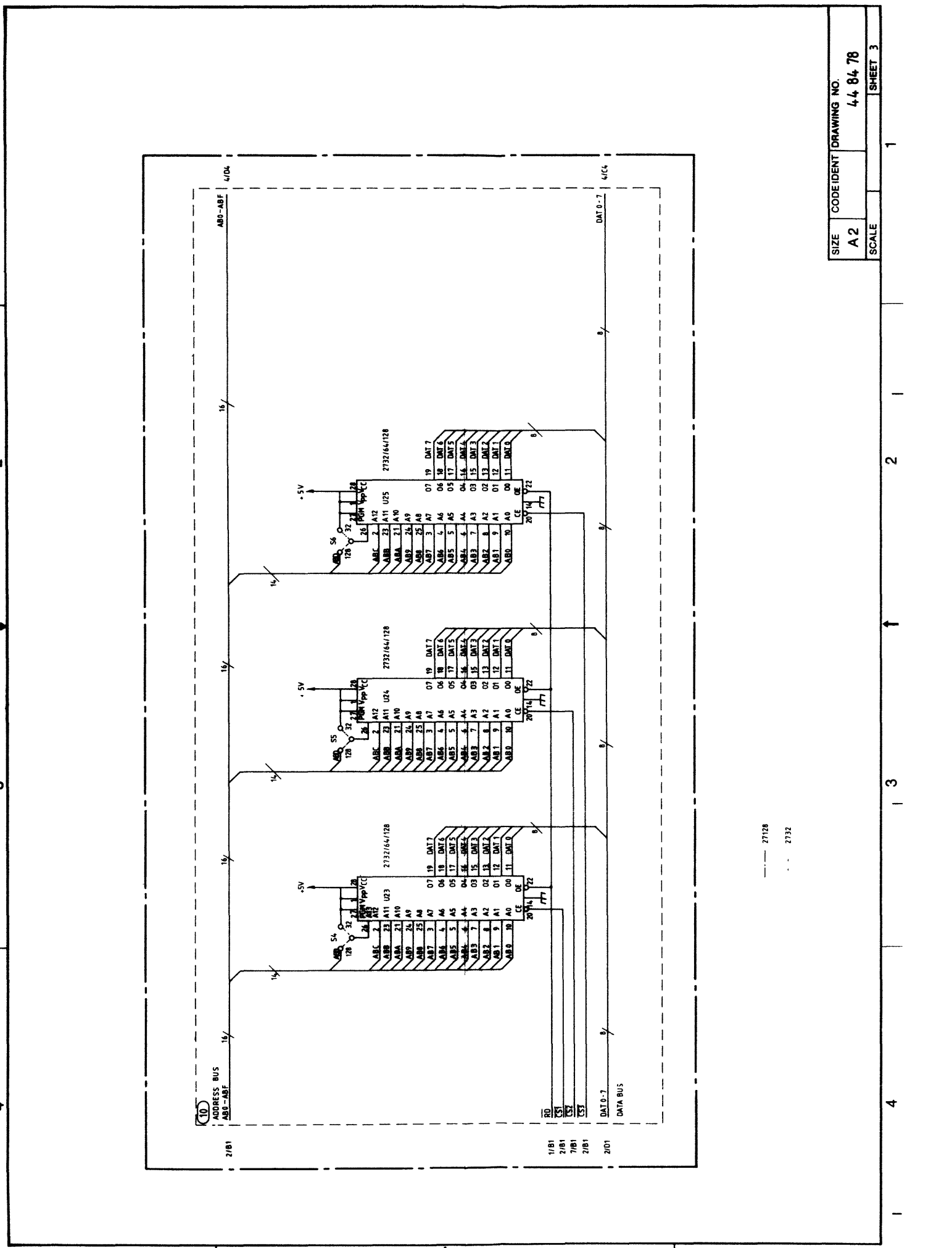

SIZE	CODE IDENT	DRAWING NO.
A 2		44 84 78
SCALE		SHEET 3

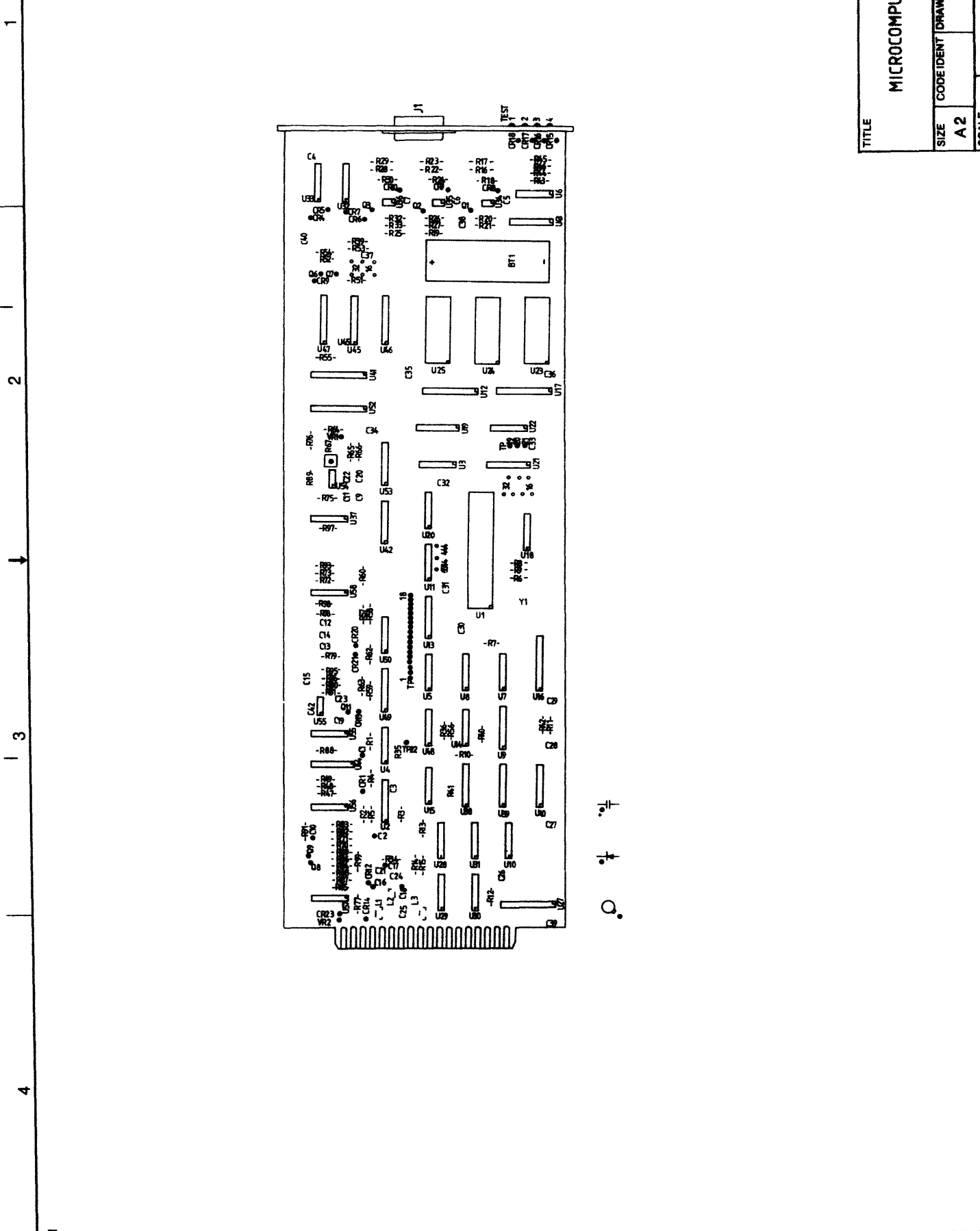

TITLE

MICROCOMPUTER

SIZE A 2

CODE IDENT DRAWING NO. 4,84,78

SCALE

SHEET 1 OF 1

- ⑪ Circuit that ensures power to CMOS-gates (U49, U50) and CMOS-RAM (U47).

BT1 is a lithium battery and R51 protects the battery against serious damage if a short circuit appears.

- ⑫ RAM-Area, consisting of two 1K x 4 bit, U45-U46 working as one 1K x 8 bit. U47 is a 1K x 4 bit CMOS RAM, working as a continuous memory.

- ⑬ \overline{PWRLO} sets U14b and U50a. The program reads U14b's status, and stores relevant information in CMOS-RAM (U47). Setting U50b protects CMOS-RAM (U47) against writing when power is removed.

During start-up U14b will be cleared by a \overline{RESET} , and the program will read U50a's status to see if there has been a power-fail or if power has been removed by turning "Pwr off" to the front panel. The program will then enable CMOS-RAM (U47) by clearing U50B and U50a.

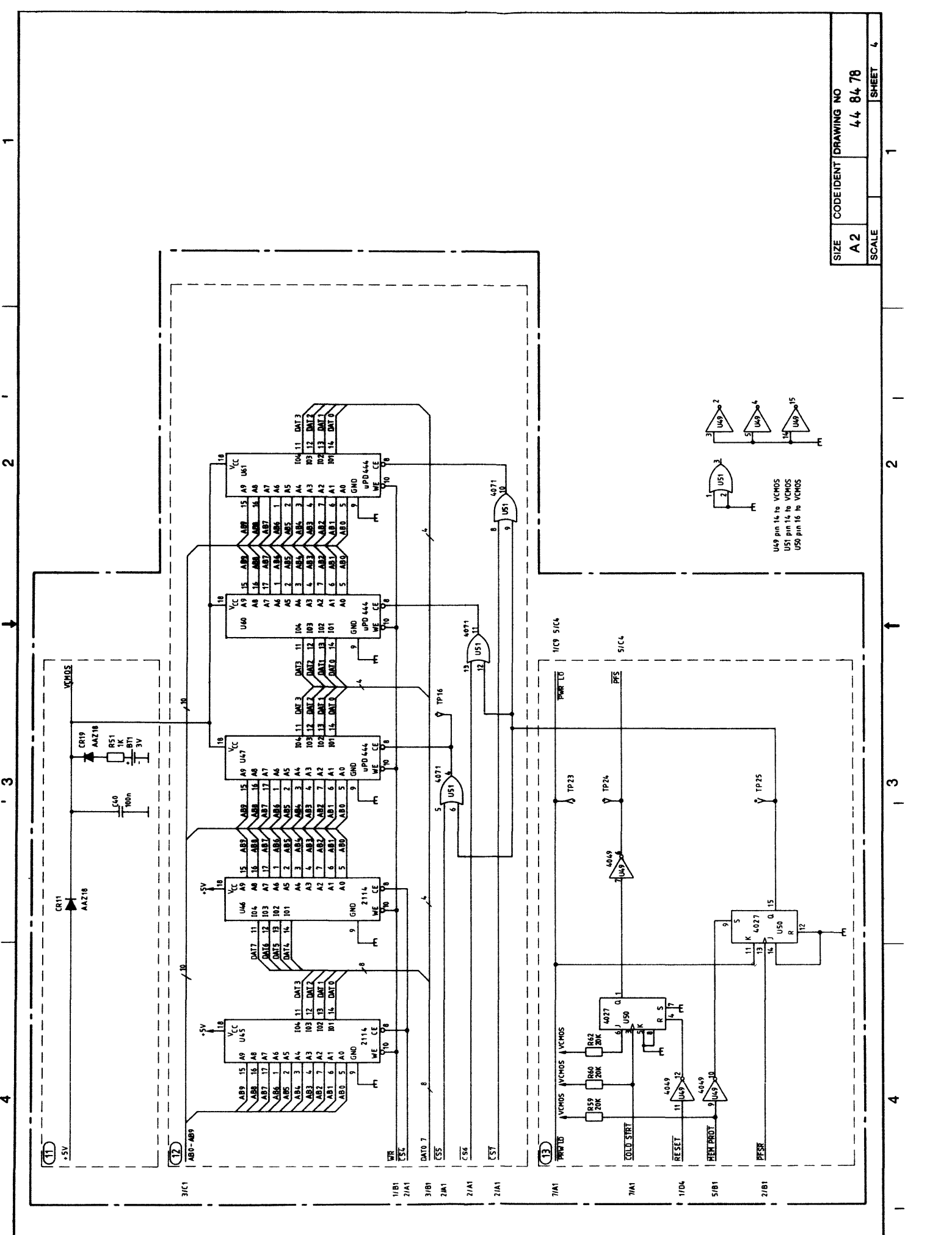

SIZE	CODE IDENT	DRAWING NO
A2		44 84 78
SCALE		SHEET 4

1 2 3 4

D

C

B

A

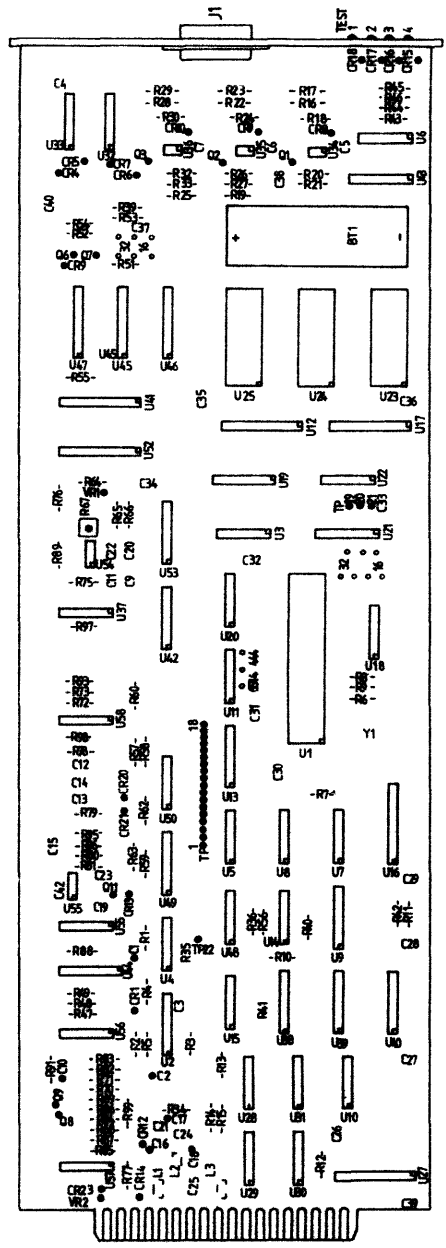

Q. 7. 1

TITLE		MICROCOMPUTER	
SIZE	A 2	CODE IDENT / DRAWING NO.	4, 484, 78
SCALE		SHEET	1 OF 1

1 2 3 4

- ⑭ Timer that counts the CLK-signal from the microprocessor Output from the timer gives a RST 7.5 interrupt to the microprocessor every 1ms, and a clock pulse to ③.
- ⑮ Eight bit input port.
- ⑯ U42: Eight addressable latches used for control signals.
U44: One out-of-four decoder with associated pull-up resistors, used for control signals.
- ⑰ Four bit latch with associated buffers and LED's.

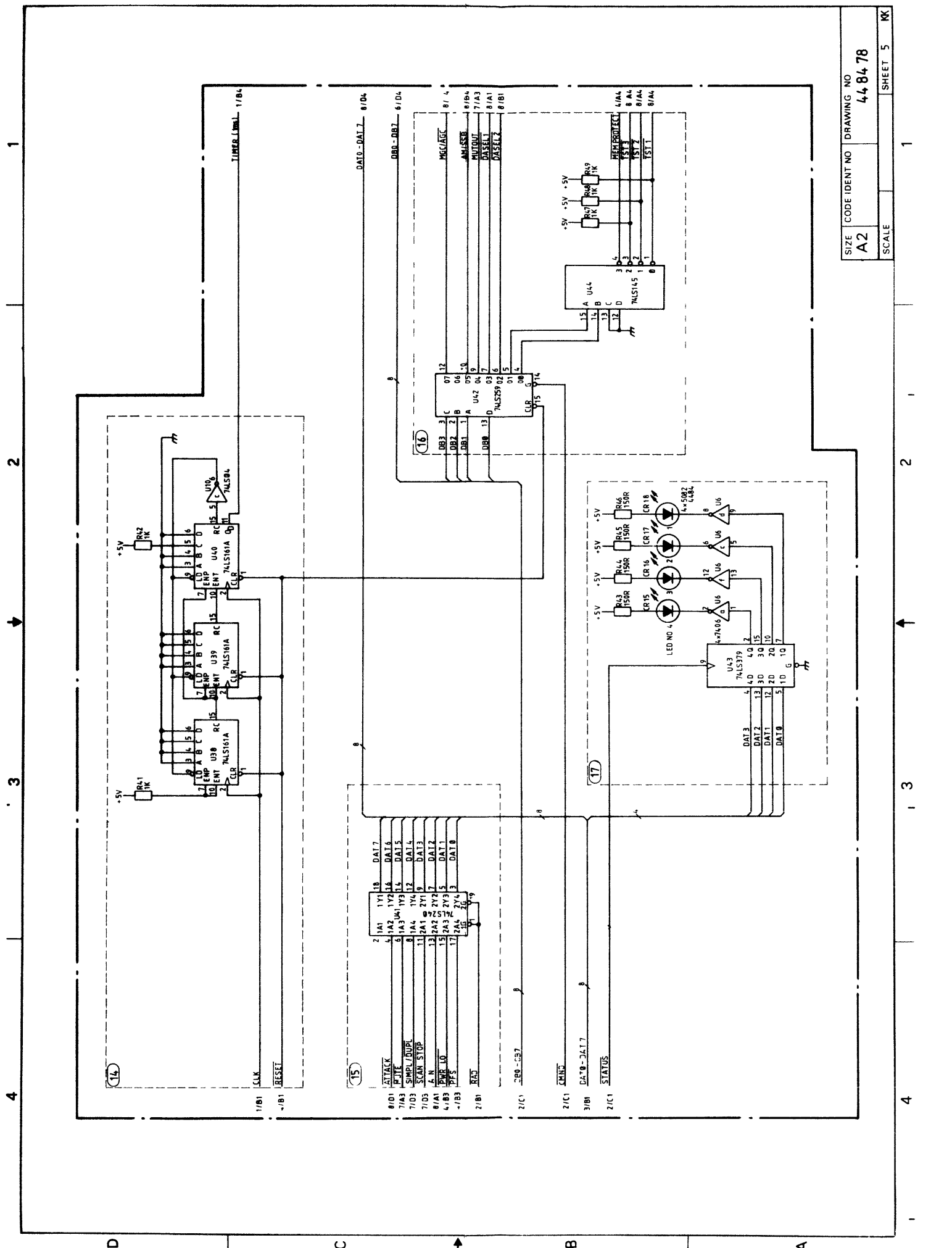

SIZE CODE IDENT NO DRAWING NO
 A2 448478
 SCALE SHEET 5 KK

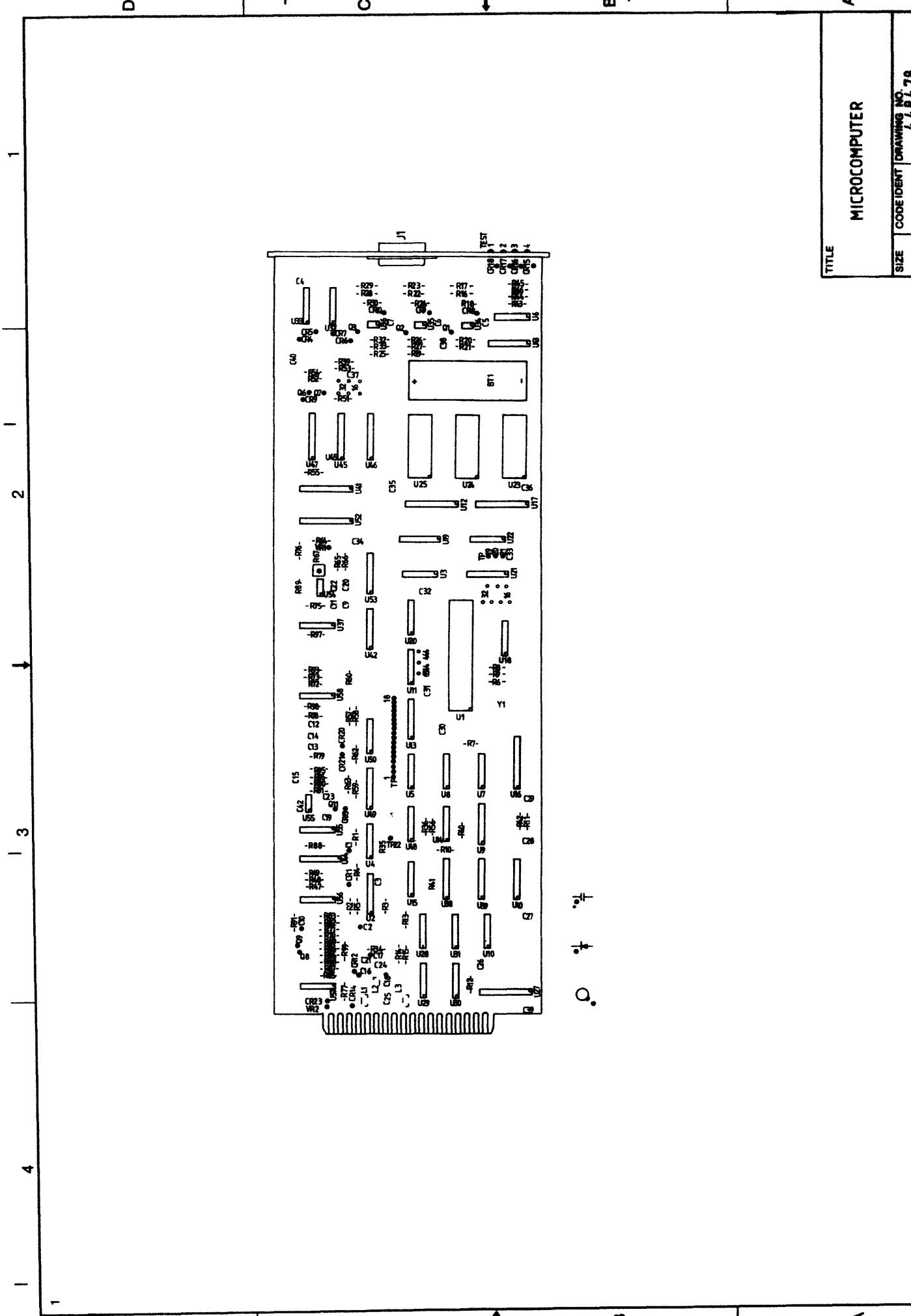

0.1

TITLE		MICROCOMPUTER	
SIZE	A2	CODE IDENT	DRAWING NO. 448478
SCALE		SHEET 1 OF 1	

- (18) Supply filters.
- (19) U27: Eight bit bidirectional data bus buffer, which is enabled during off board operations.
- (20) Circuit to provide at least 1 wait-state in the micro-processor timing, during off board write operations. This ensures that data is valid on the rising edge of \overline{FWR} .

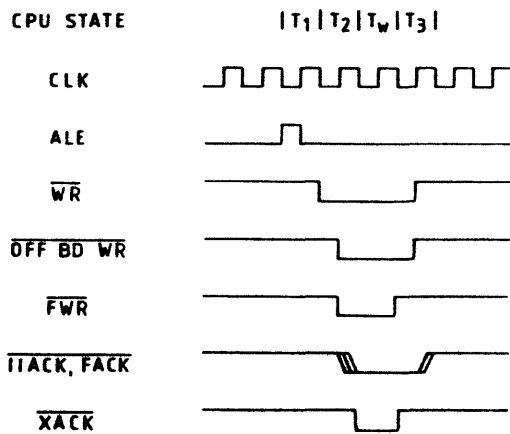

Timing diagram for generating of 1 wait-state,

- (21) Buffers for off board address- and command-signals.

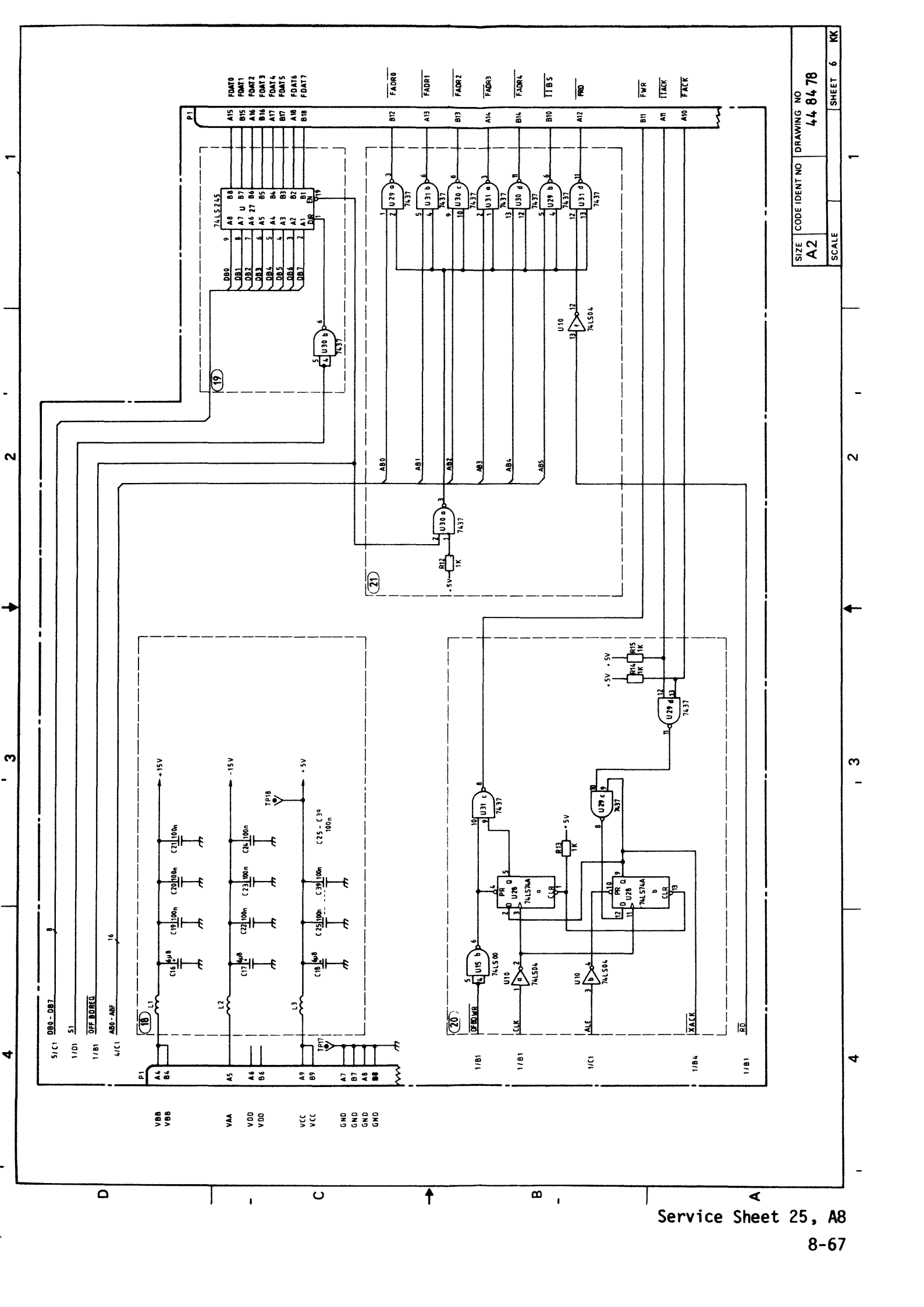

SIZE	CODE IDENT NO	DRAWING NO
A2		44 84 78
SCALE		SHEET 6 KK

D

C

B

A

1 2 3 4

1 2 3 4

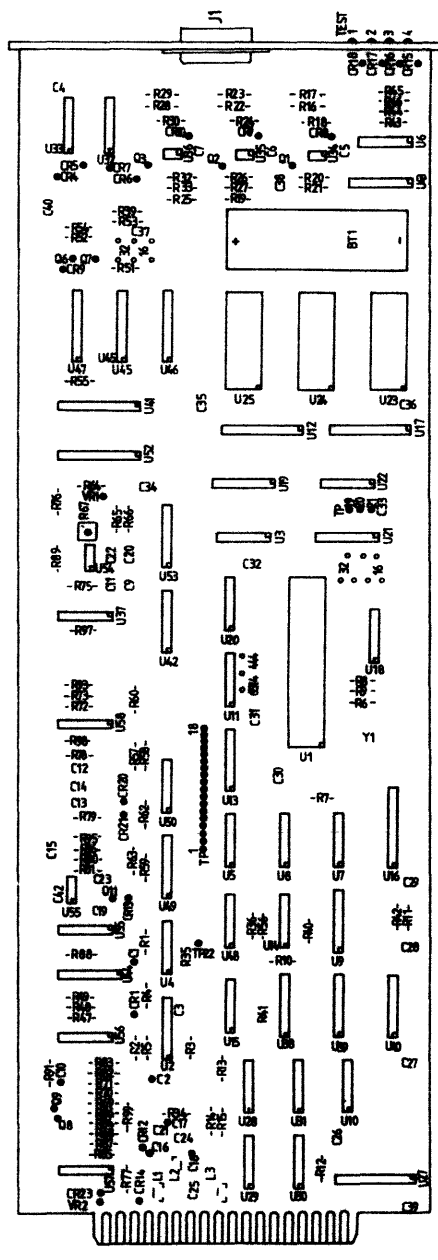

TITLE

MICROCOMPUTER

SIZE

A 2

CODE IDENT

DRAWING NO.

448478

SCALE

SHEET 1 OF 1

REV. 1.1.1. 08/82

D

C

B

A

(22) RS232 interface for serial communication, optional.

(23) Optocoupler interface to ensure electrical separation between incoming signals and on board signals.

External signal generators shall be 24V, 10mA, to provide a proper TTL-signal on Q1's, Q2's or Q3's collector.

(24) Diode network CR13 and CR14 is for protection. R34, CR12 ensures current through the connector when $\overline{\text{PWRON}}$ is low.

If power is removed by turning "Pwr off" to the front panel, PWRON goes high, and provides U50a in 13 to be cleared, by means of $\overline{\text{COLD STRT}}$.

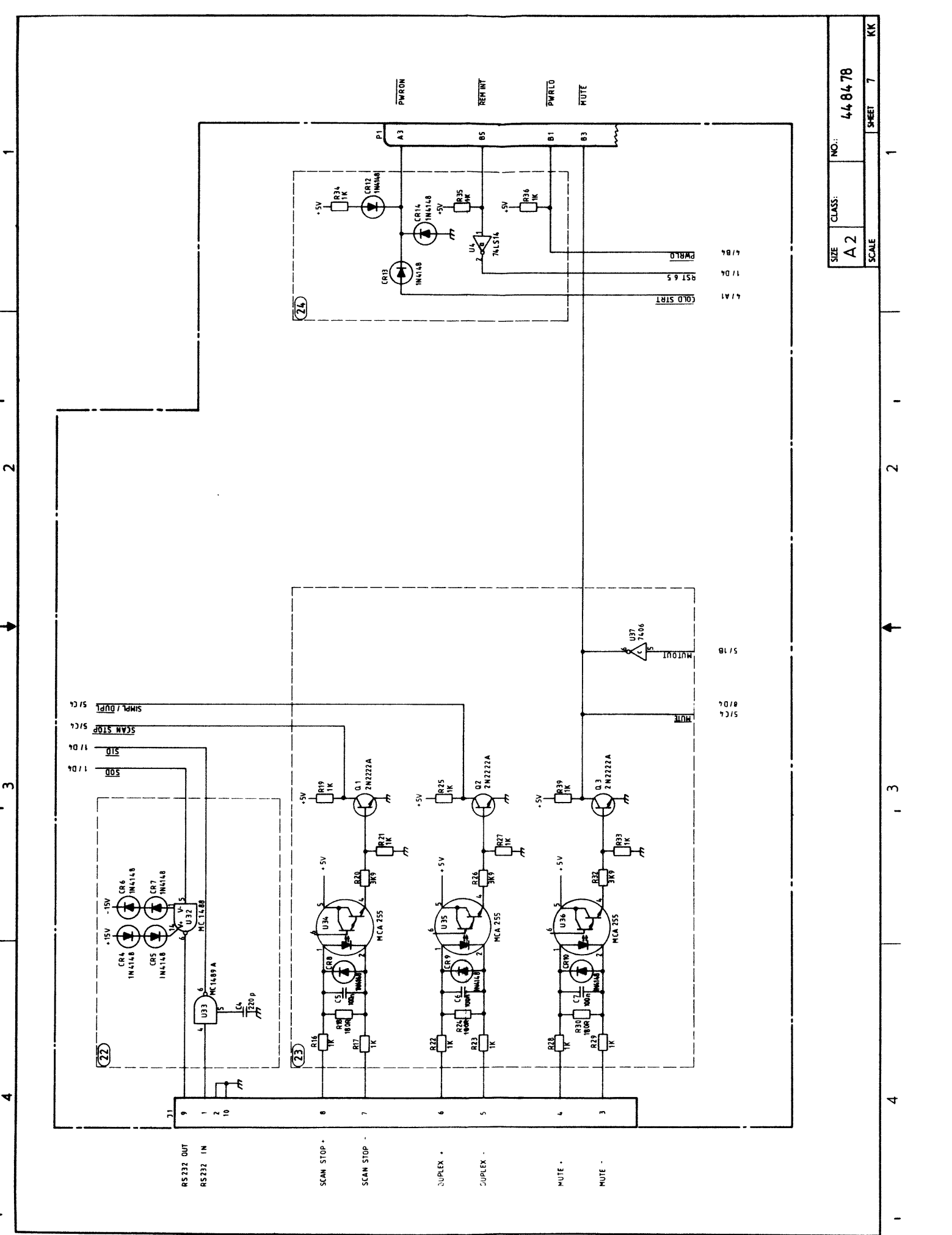

SIZE	CLASS:	NO.:
A2		448478
SCALE	SHEET	7
		KK

Service Sheet 26, A8

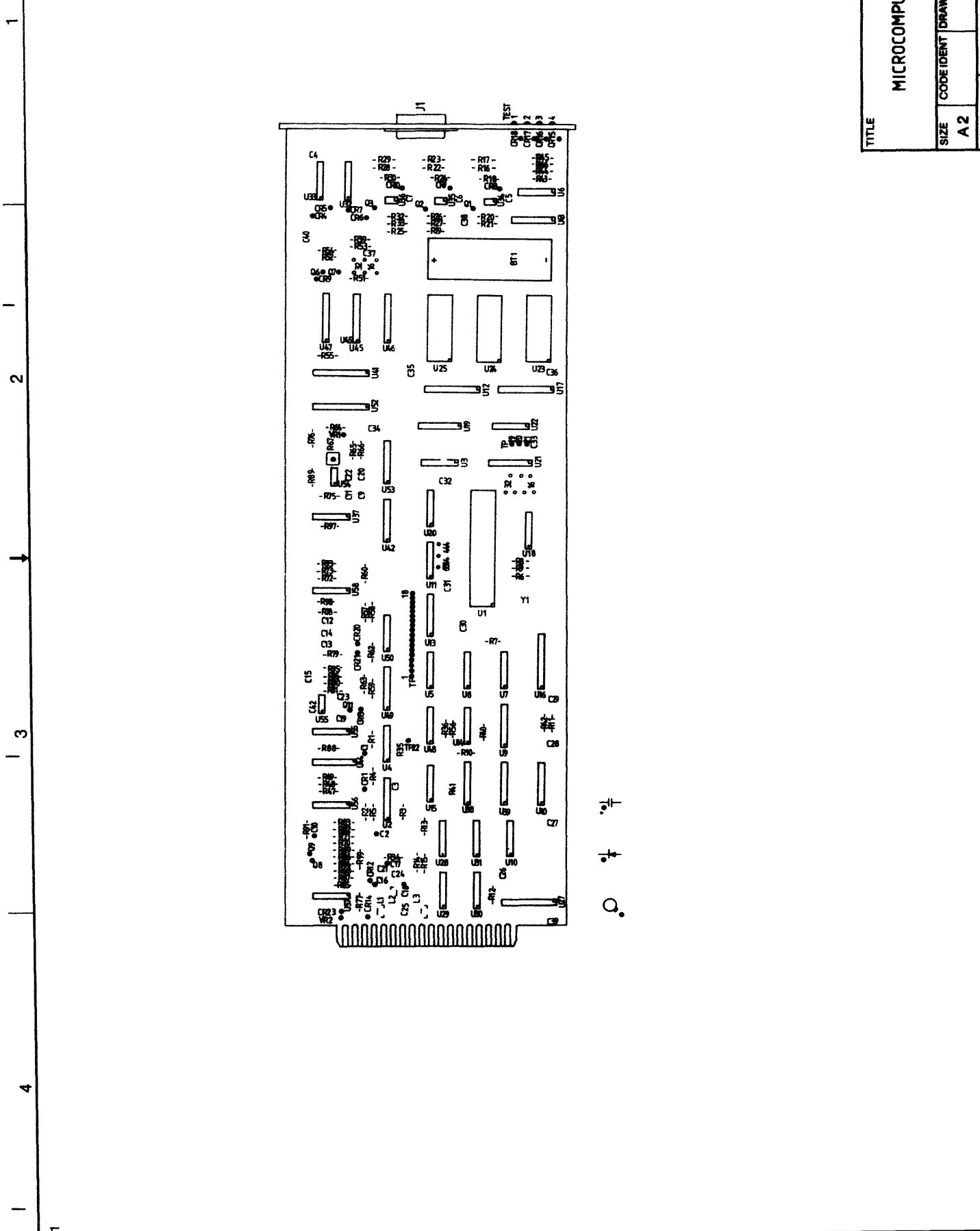

TITLE		MICROCOMPUTER	
SIZE	CODE IDENT	DRAWING NO.	4,84,78
A 2			
SCALE			SHEET 1 OF 1

1
2
3
4

D
C
B
A

- (25) U52: Eight bit latch.
U53: Eight-bit Digital to Analog converter with associated resistor network.
U54: Operational amplifier with an output range set by R67.
The maximum output may be adjusted to 10V.
- (26) Circuit to provide an $\overline{\text{ATTACK}}$ as long as Q9 is open. To avoid spikes causing an $\overline{\text{ATTACK}}$ R91, C10 determines the minimum time Q9 has to be open. R70, R71, C10 holds the $\overline{\text{ATTACK}}$ to ensure the microprocessor reads the $\overline{\text{ATTACK}}$.
- (27) A $\overline{\text{MUTE}}$ - Signal will force the AGC2 to +15V DC (maximum attenuation).
- (28) U57: Analog switch. If closed then Automatic Gain Control is selected.
CR23 protects U57 against negative levels.
- (29) Gain Control filter. When U58 (analog switch) is closed, the filter is set up for Single Side Band mode.
U55 is an operational amplifier used as a buffer.
- (30) Sample hold circuit used to give a digital AGC-level to AGC 2. The microprocessor controls the hold and decay-level of the AGC2.
- (31) By means of the comparator U59 and the D/A-converter in (25) an A/D-conversion of either AGC1, AGC2 or a test level can be performed.
- (32) Sample hold circuit used to give a digital AGC-level to AGC1.

R82 protects U55 when muting.

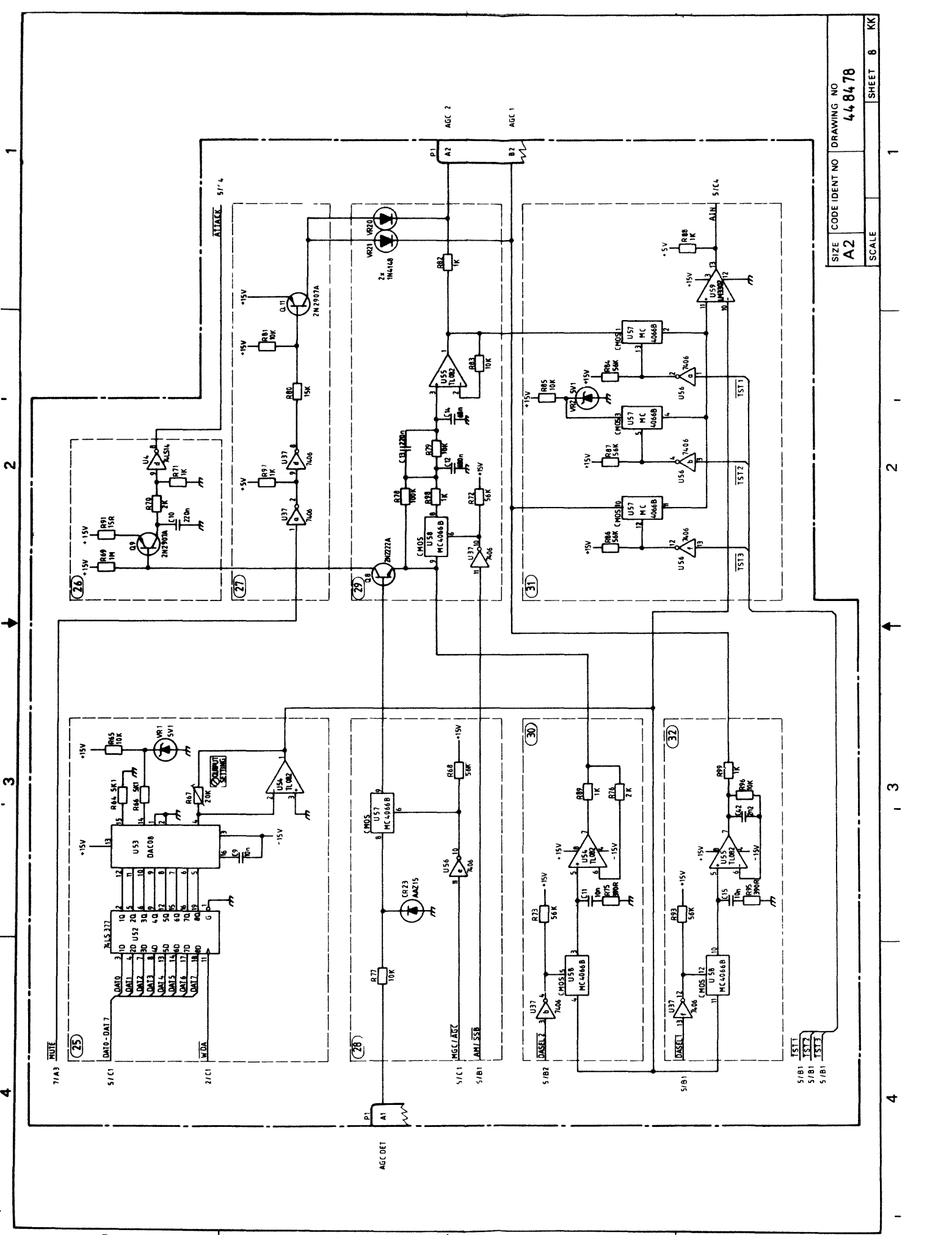

SIZE	CODE IDENT NO	DRAWING NO
A2		448478
SCALE		SHEET 8 KK

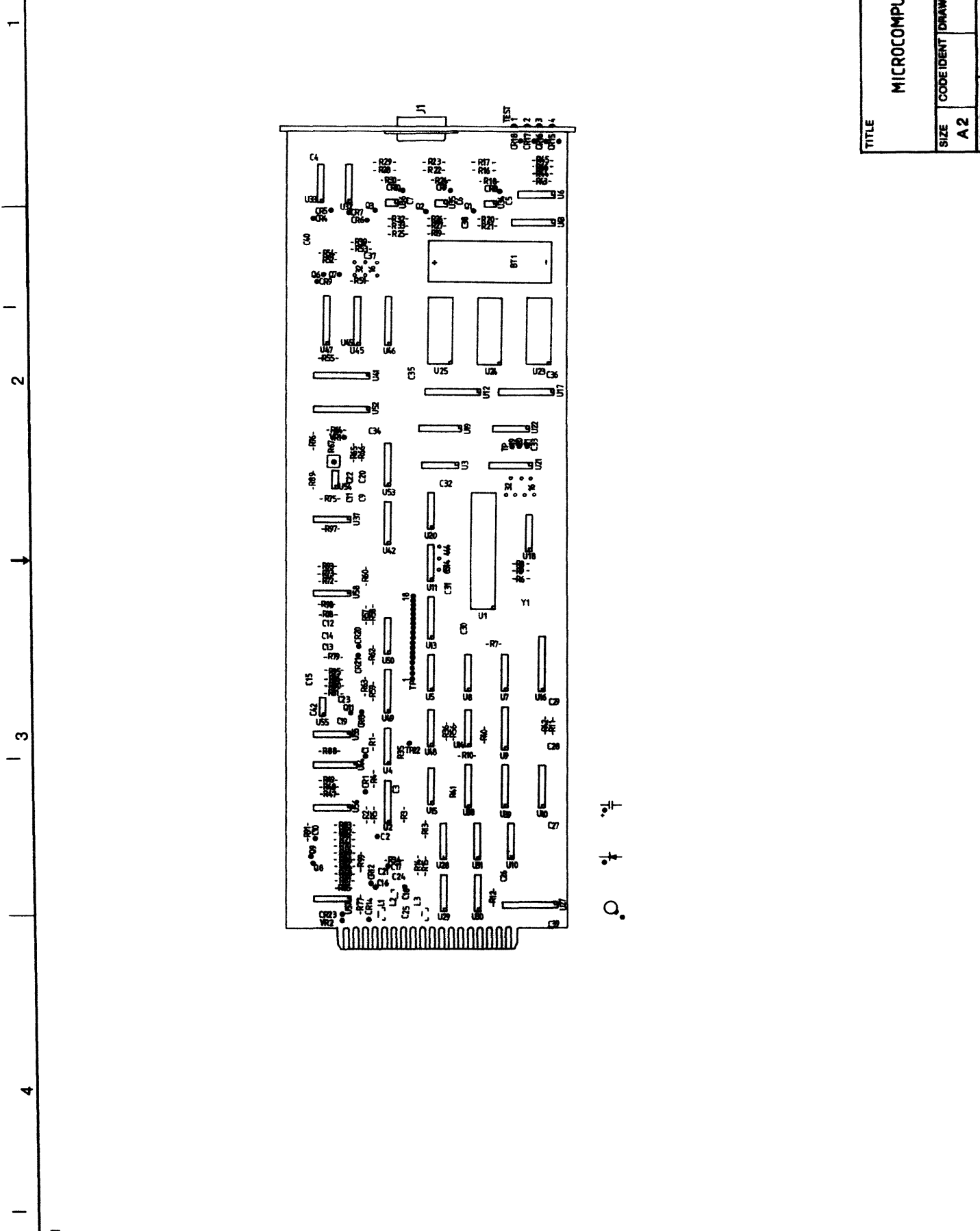

TITLE

MICROCOMPUTER

SIZE

A 2

CODE IDENT

DRAWING NO.

4,84,78

SCALE

SHEET 1 OF 1

DATE

11.11.1984

1 2 3 4

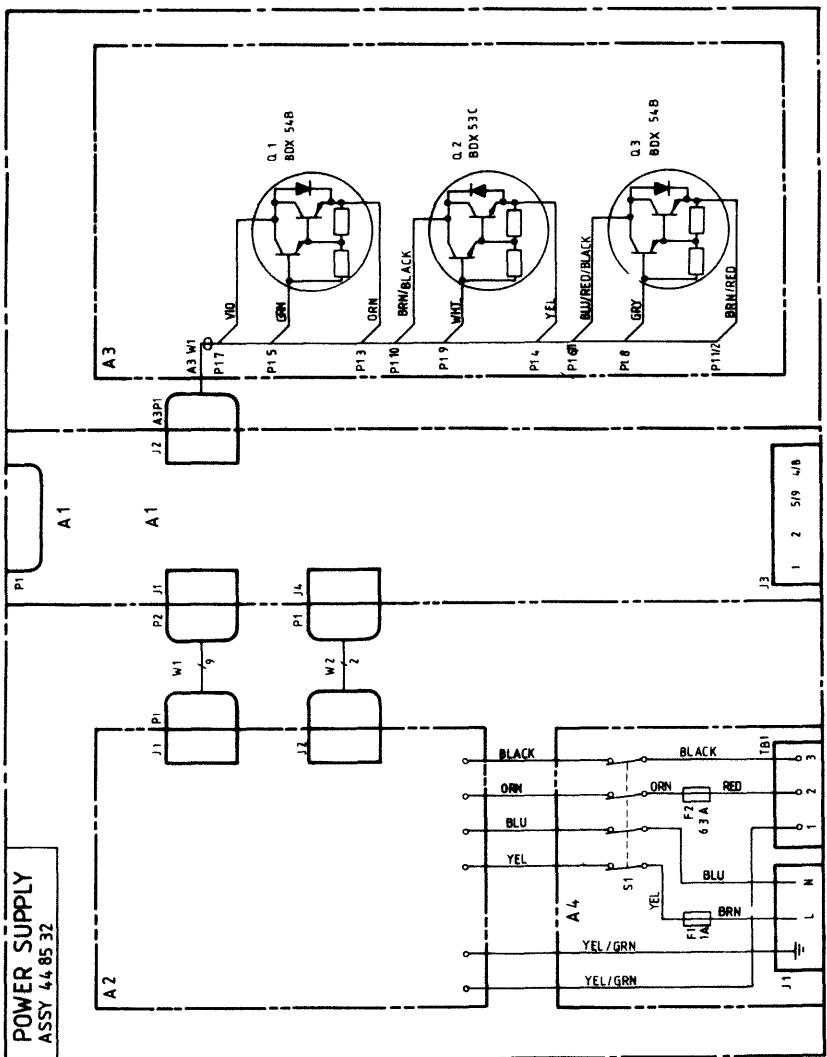

± 24VDC
 AC MAINS
 GND
 SIDE TONE INPUT
 4-w/4W LOUD SPEAKER

POWER SUPPLY
 ASSY 44 85 32

TITLE POWER SUPPLY		
SIZE A 2	CLASS	NO 44 85 32
SCALE	SHEET 1 OF 1	

1 2 3 4

D A B A

- ① VEE supply filter
- ② -15V reference voltage regulator.
The reference voltage is adjusted to -14.8V @ 25°C by means of R19
- ③ Standby/On switch circuit. When P1-A3 is grounded Q7 is switched on supplying +15V to ④
- ④ U5 forms part of the PWRL0 detector. C16, R38 and R39 generate a reference ripple from the AC REF signal. The reference ripple is compared with an adjustable threshold level (R42), holding Q17 in the off state when the reference ripple exceeds the threshold level. Q8 and Q18 ensure a PWRL0 signal during start-up until VBB reaches VEE.
- U5 generates in addition the 5V reference voltage for ⑤, ⑥ and ⑦. The 5V reference voltage is adjusted by means of R40.

- ⑤ +15V - VBB regulator.
U2 compares VBB/3 with the 5V reference voltage and supplies the regulating current for the driving transistor Q2.

U1 forms the current limiting circuit. When the R10 voltage drop exceeds the R9 voltage drop, U1 shunts the regulating current for Q2 producing a fold-back characteristic.

Service Sheet 29, A10A1

8-74

Q3, VR1 and R17 form crow-bar protection on the regulator output voltage. The trigger point for Q3 is approx. +17V.

- ⑥ -15V - VAA regulator.
U4C compares VAA with three times the 5V reference voltage and supplies the regulating current for the driving transistor Q5.
- U4b forms the current limiting circuit similar in operation to ⑤. Q6, VR2 and R37 form crow-bar protection on the regulator output voltage. The trigger point for Q6 is approx. -17V.
- ⑦ +5V-VCC/VDD regulator.
U4d compares VDD from a mother board sense point (P1-B6), or through R53, with the 5V reference voltage and supplies the regulating current for the driving transistor Q10.

U4a forms a current limiting circuit similar in operation to ⑤. Q11, VR4 and R63 form crow-bar protection on the regulated output voltage. The trigger point for Q11 is approx. +6.2V.

1 2 3 4

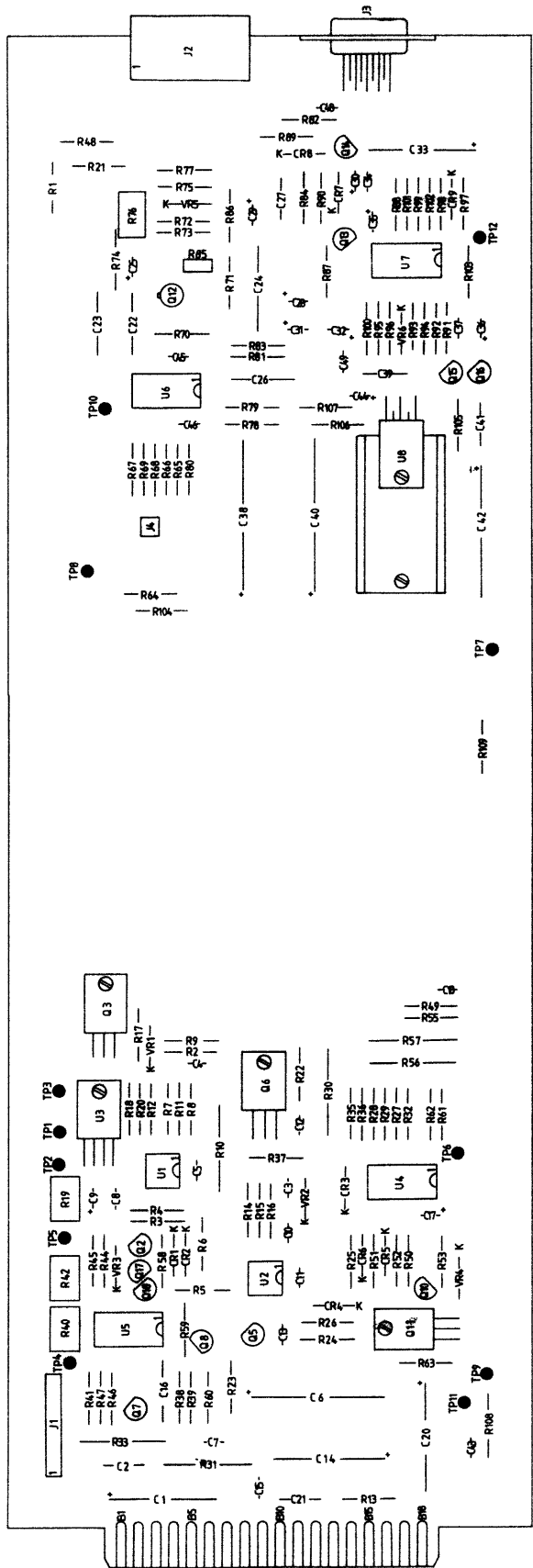

TITLE		POWER SUPPLY	
1		REGULATOR AND AF ASSY	
SIZE	CODE IDENT	DRAWING NO	
A1		44859	
SCALE		SHEET 1 OF 1	

1 2 3 4

D C B A

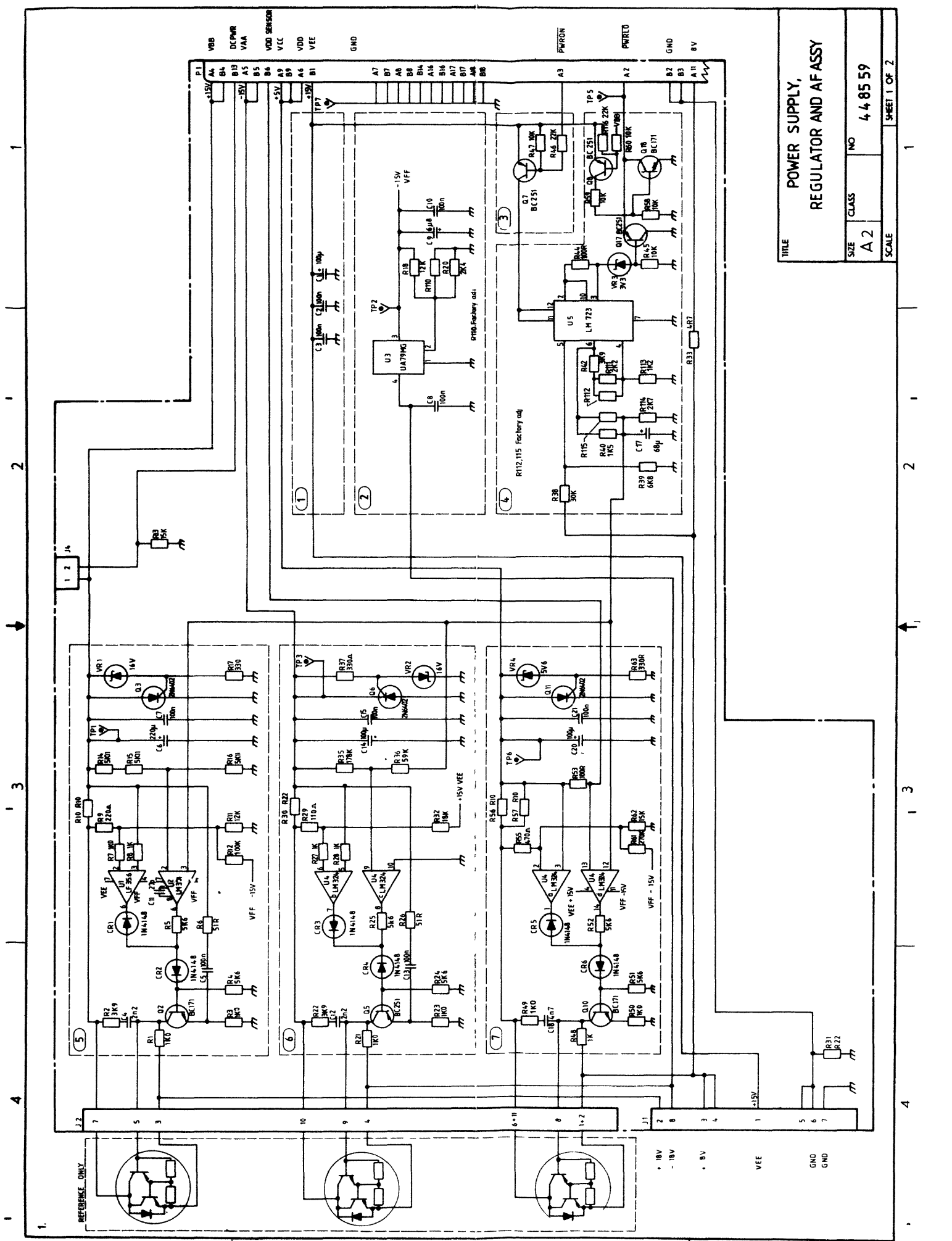

TITLE			
POWER SUPPLY, REGULATOR AND AF ASSY			
SIZE	CLASS	NO	SCALE
A 2		4 4 85 59	
SHEET 1 OF 2			

Service Sheet 29, A10A1

8-75

⑧ Notch-filter.

U6a, U6b and U6c form an inverting, voltage-controlled, band-pass filter with unity gain. The notch characteristic is obtained by adding the non-inverted input signal to the inverted output signal. Q12 acts as voltage controlled resistors in the filter. The filter is adjusted by means of R76 to 1kHz notch tune when TP9 is set to -11,5V.

⑨ Notch Control.

R84, R85, R86 and C29 filter and temperature stabilize the filter control voltage.

By means of Q13 and Q14 the notch filter may be bypassed. When TP9 reaches -15V, Q13 is switched on whereby the band-pass filter output is grounded.

U6d forms a summing amplifier for AFDET, band-pass filter output, and "Side-Tone" input.

⑩ AF-gain Control.

The AF signal from ⑨ is routed to U7-11. The control voltage between U7-6 and U7-9 adjusts the AF signal level at R103 by means of the emitter coupled amplifier within U7. The control voltage is derived from the AF gain control adjustment. The overall gain of the stage may be con-

trolled from -60 dB to approx. 0 dB.

⑪ AF Output Amplifier

U8 forms the AF output amplifier. The stage has a voltage gain of approx. 38 dB and is capable of delivering up to 4W in a 4 Ω load.

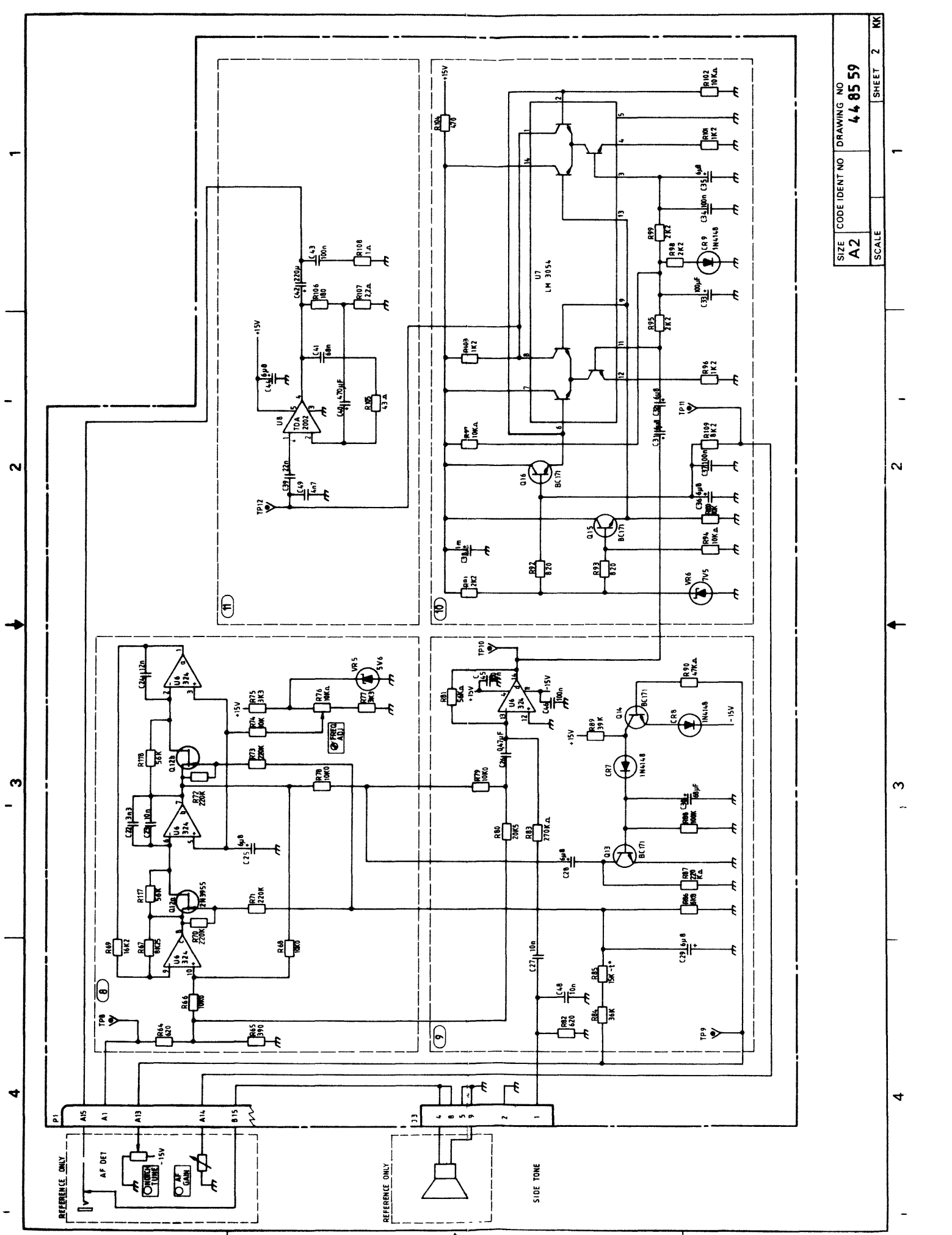

SIZE	CODE IDENT NO	DRAWING NO
A2		44 85 59
SCALE		SHEET 2 KK

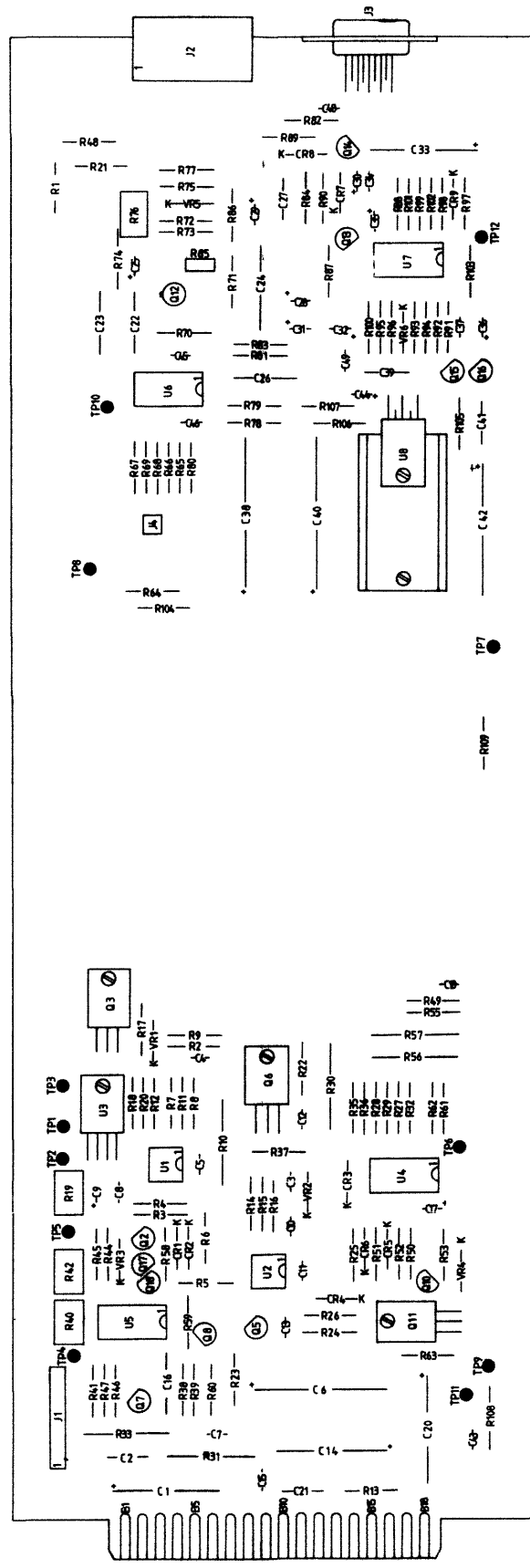

① EMI filter for AC-mains supply.

② AC-mains sensor.

③ EMI-filter for DC-24V supply.

④ DC/AC switch circuit.

When AC-mains is available U1 will discharge C10 during each positive half cycle.

When AC-mains is removed C10 will be charged through R3.

By means of Q1 the relay K1 will be energized whereby the mains transformer will be disconnected from mains, Q2 starts to conduct and ⑤, ⑥ and ⑦ receive a supply voltage.

When the AC-mains is restored C10 will be discharged, the relay K1 will be deenergized and ⑤, ⑥ and ⑦ returned to the stand-by state.

⑤ +5V regulator for inverter control.

⑥ 170 Hz oscillator.

⑦ U4 forms a Flip-Flop alternating the "on" state of Q3 and Q4. The output cycle frequency is 85 Hz.

⑧ Push-Pull transistors Q5 and Q6 alternate the current through the tertiary winding of the mains transformer. Q7 and Q8 act as current limiters and VR5 and VR6 as voltage limiters.

⑨ Mains transformer with 110V/220V straps.

For 110V supply, strap 1-2,3-4,5-6

For 220V supply, strap 2-3

⑩ Rectifiers and filters.

⑪ +15V regulator for stand-by supply. By means of R18 the voltage is adjusted to +14,8V @ 25°C.

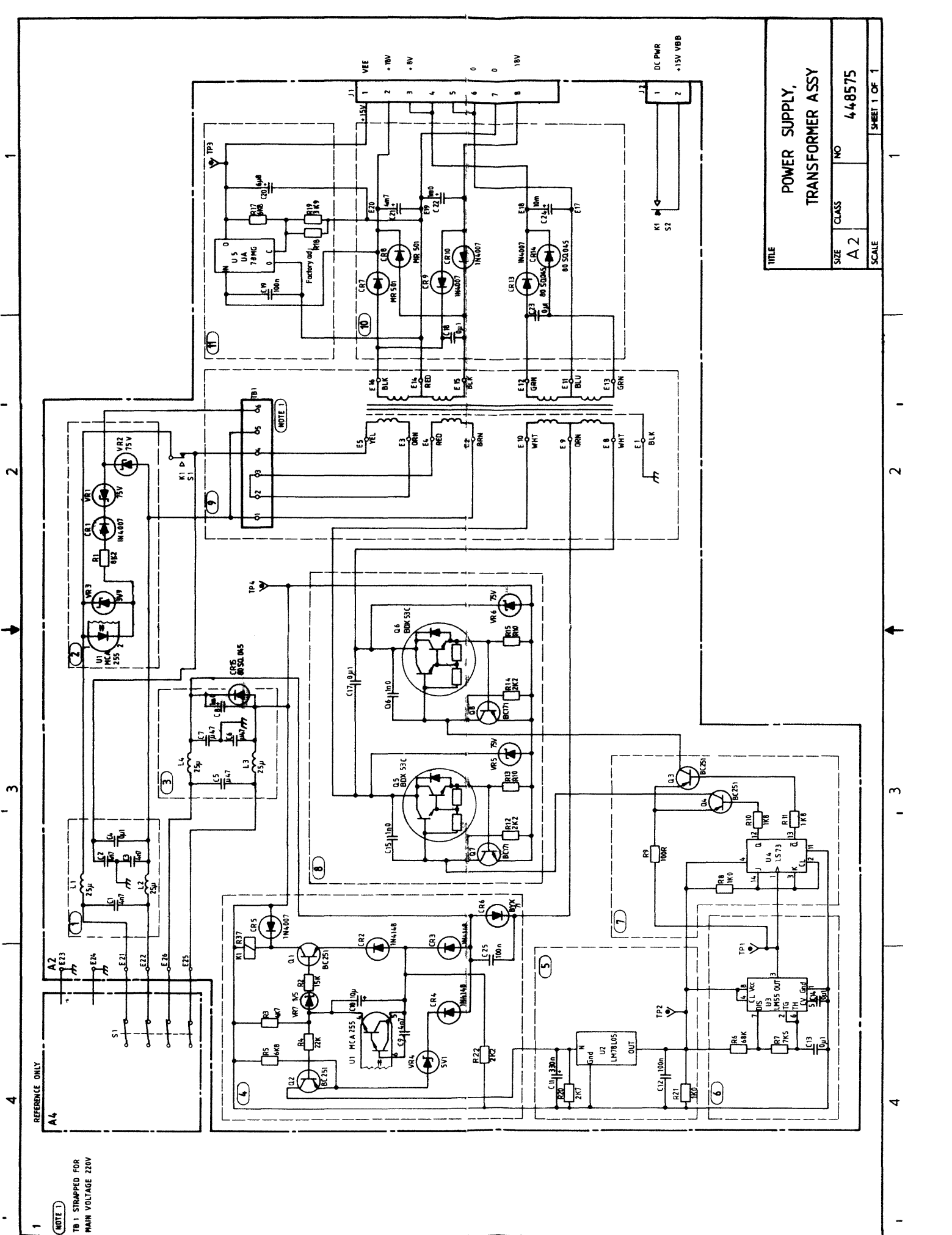

TITLE		POWER SUPPLY, TRANSFORMER ASSY	
SIZE	CLASS	NO	448575
A 2			
SCALE			SHEET 1 OF 1

NOTE 1
TB 1 STRAPPED FOR
MAIN VOLTAGE 220V

REFERENCE ONLY
A4

1 2 3 4

D C B A

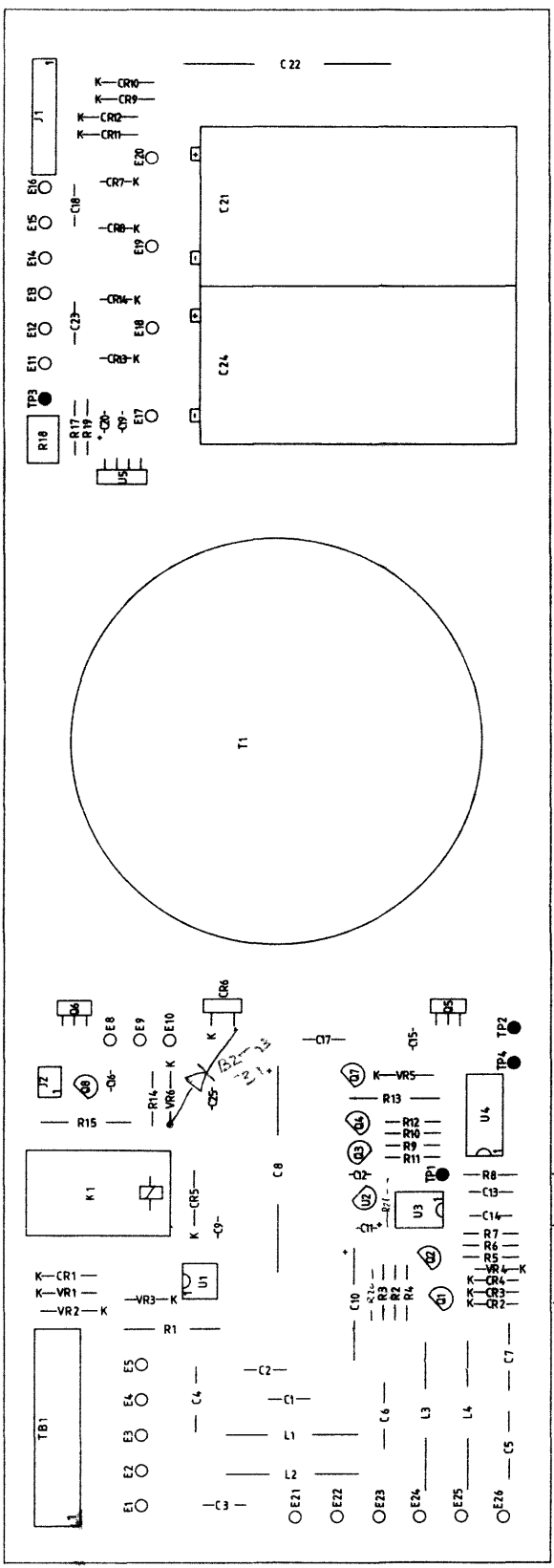

ON SOLDERING SIDE

TITLE		POWER SUPPLY, TRANSFORMER ASSY
SIZE	CODE IDENT	DRAWING NO
A1		44-8575
SCALE	2:1	SHEET 1 OF 1

ASSY 448591, FRONT PANEL CIRCUIT Schematic 1

- ① Address decoding with associated gates for generation of acknowledge \overline{FACK} , as handshaking signal for the microcomputer.

- ② Supply filters.

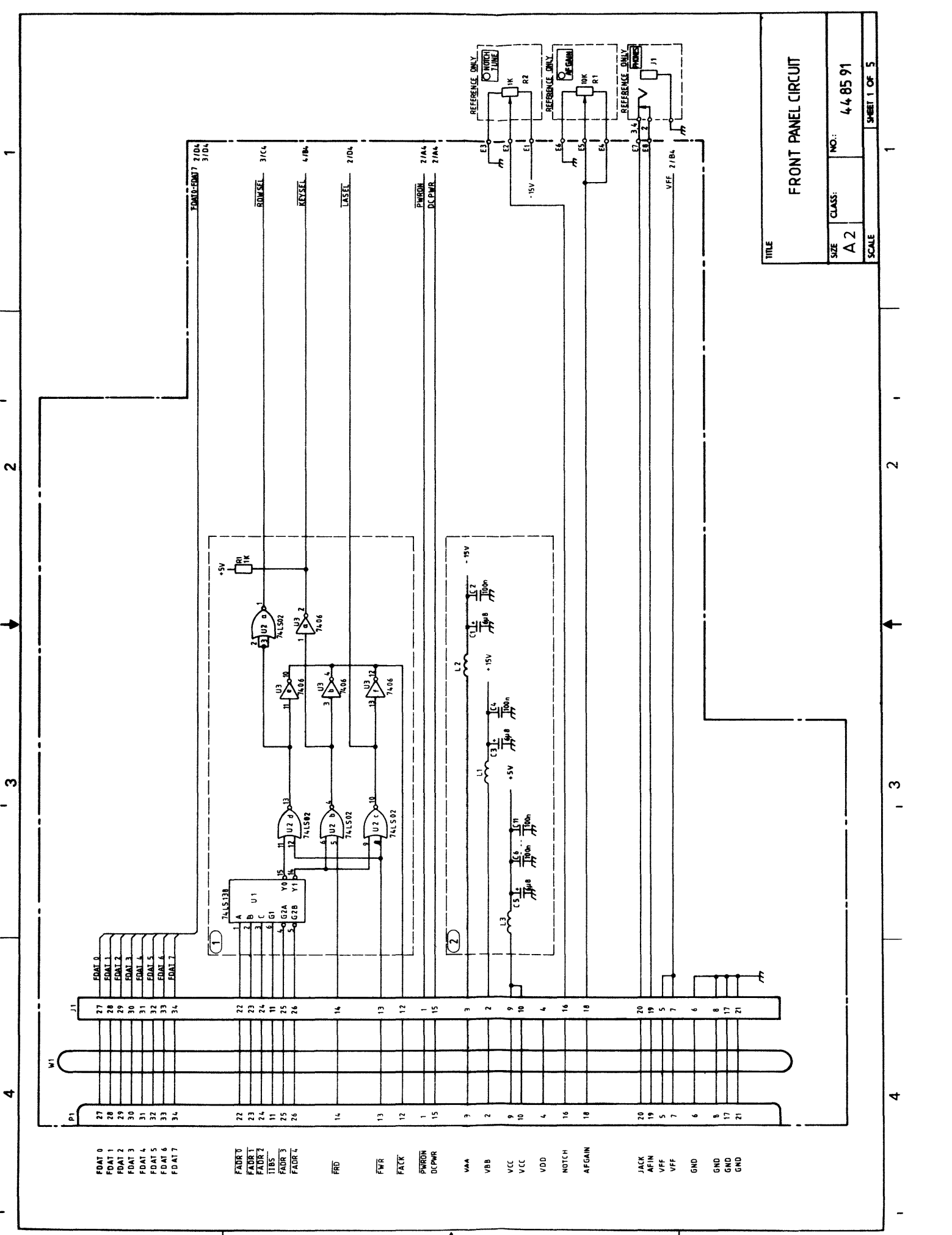

1
2
3
4

1
2
3
4

FDAT 0
FDAT 1
FDAT 2
FDAT 3
FDAT 4
FDAT 5
FDAT 6
FDAT 7

FADR 0
FADR 1
FADR 2
FADR 3
FADR 4

TIBS

FWR
FACK
PWRON
DCPWR

VAA
VBB
VCC
VCC
VDD
NOTCH
AFGAIN

JACK
AFIN
VFF
VFF
GND
GND
GND
GND

D
C
B
A

TITLE		FRONT PANEL CIRCUIT	
SIZE	CLASS:	NO.:	44 85 91
A 2			
SCALE		SHEET 1 OF 5	

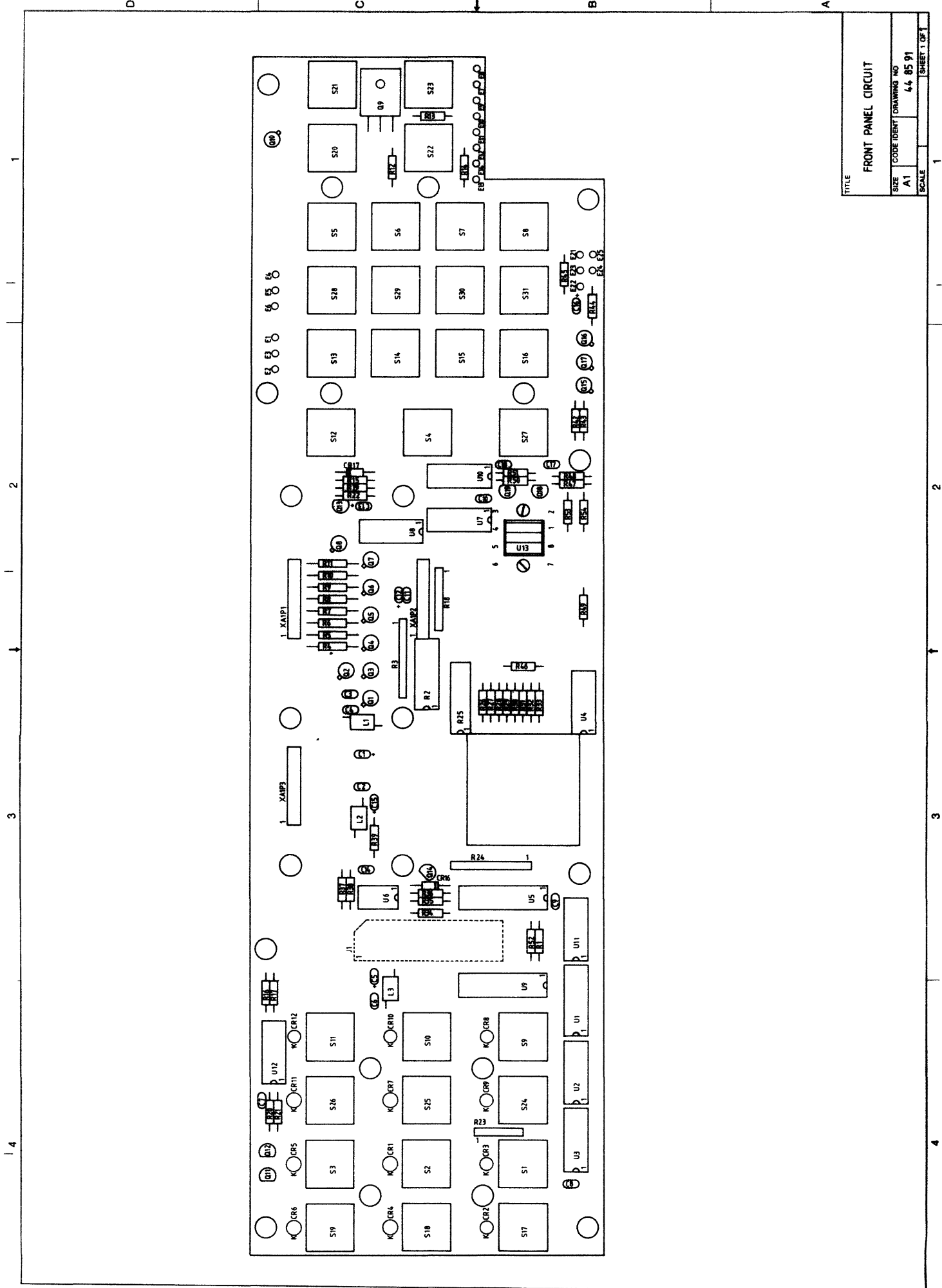

TITLE		FRONT PANEL CIRCUIT	
SIZE	CODE IDENT	DRAWING NO	
A1		44 85 91	
SCALE			SHEET 1 OF 1

③ Eight-bit latch used for segment information to displays and LED's, and data to D/A-converter ⑪

④ Q1-Q8: Drivers for segment information.
R4-R11: Current limiting resistors.

⑤ LED indicators.

CR no. Corresponding switch

1	inter
2	off
3	slow
4	WIDE
5	AM
6	SSB
7	narr
8	att
9	fast
10	vnar
11	RTTY
12	CW
13	tune
14	bfo
15	scan

⑥ Dimmer circuit, controls the light in displays, LED's and S-meter.

1 2 3 4

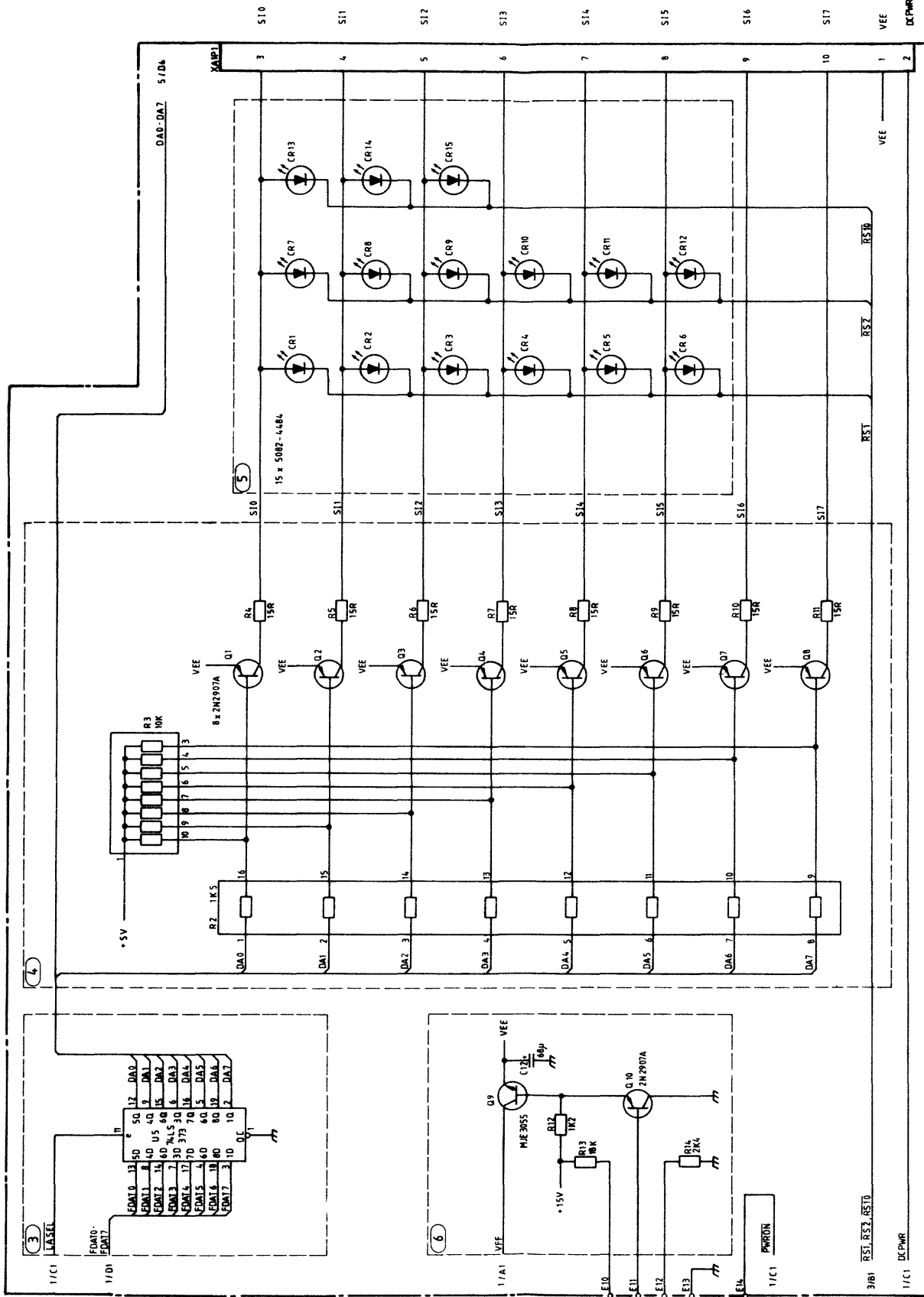

SIZE	CODE IDENT NO	DRAWING NO
A2		448591
SCALE		SHEET 2
		KK

D

C

B

A

1 2 3 4

1 2 3 4

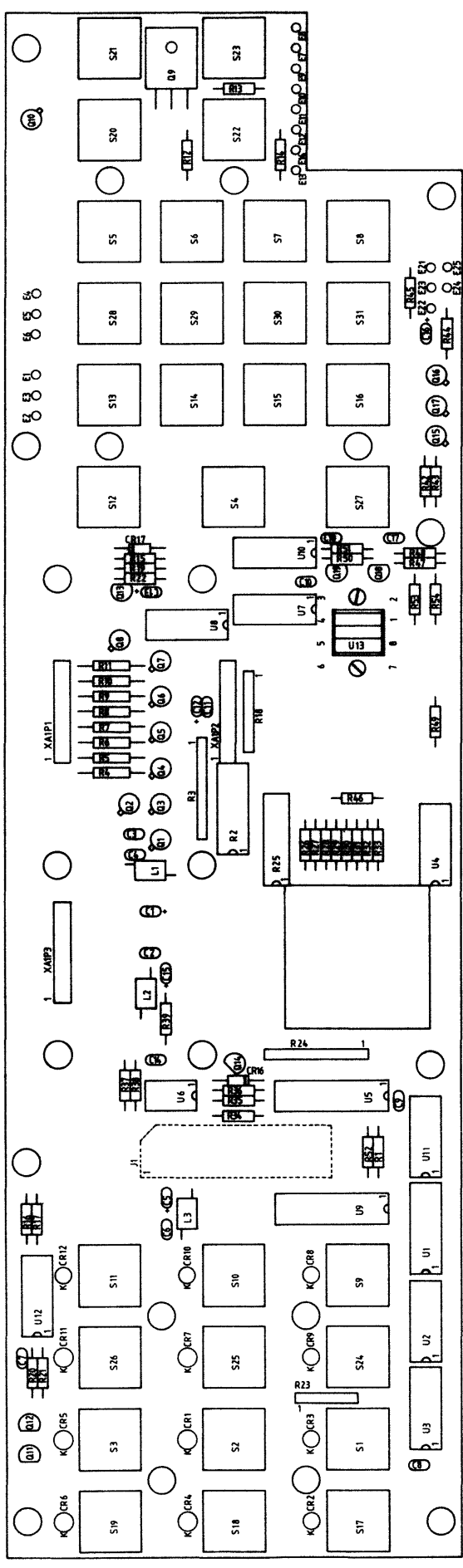

TITLE		FRONT PANEL CIRCUIT	
SIZE	CODE IDENT	DRAWING NO	
A1		44 85 91	
SCALE			SHEET 1 OF 1

⑦ U7, U8: Shift registers with associated pull-up network, used for multiplexing displays LED's and switches. It also selects the sample hold circuit ⑬, and clears tune F/F ⑫. R15, C13 clears U7 - U8 during start-up.

⑧ Drivers for multiplexing of LED's.

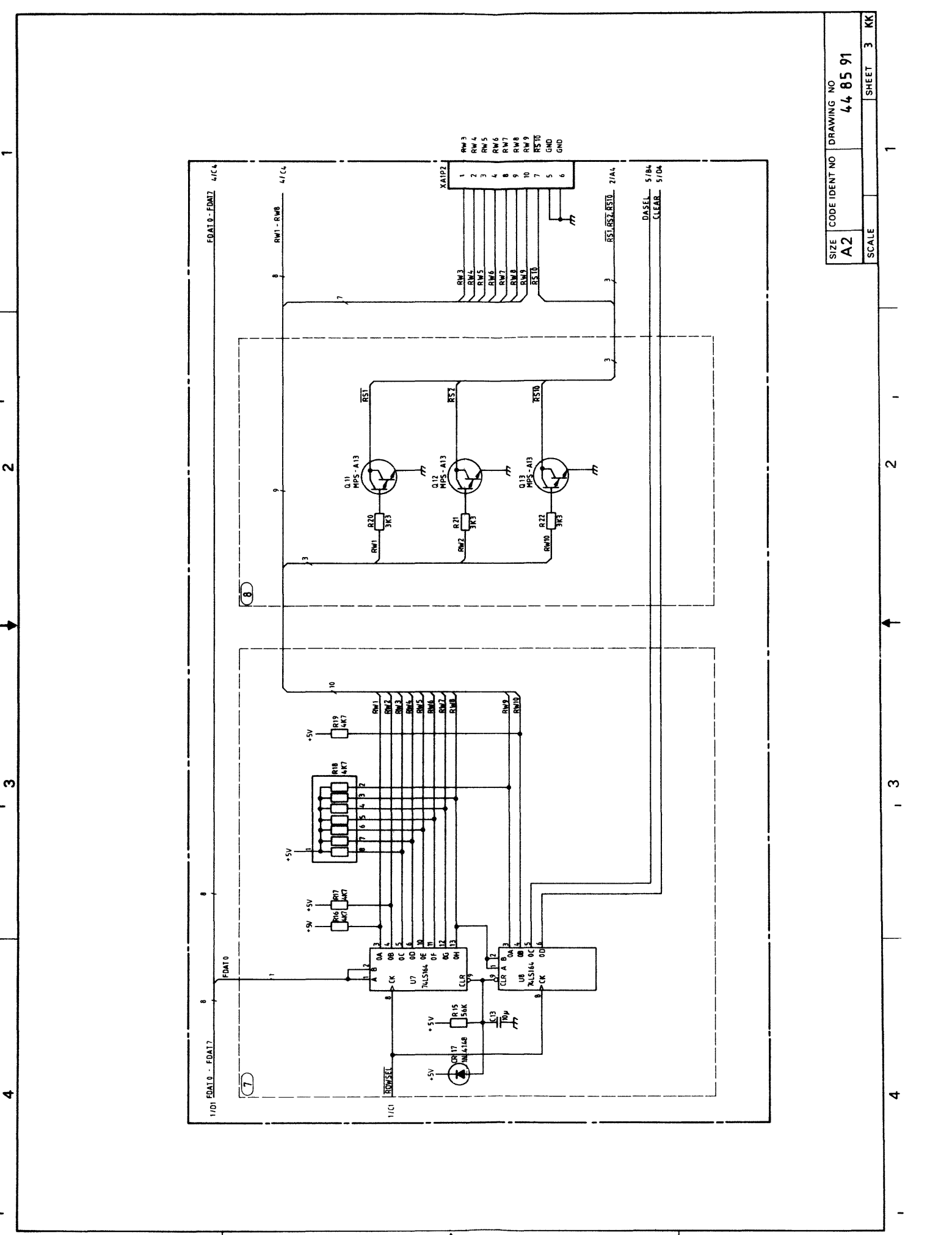

SIZE	CODE IDENT NO	DRAWING NO
A2		44 85 91
SCALE		SHEET 3 KK

1 2 3 4

D

C

B

A

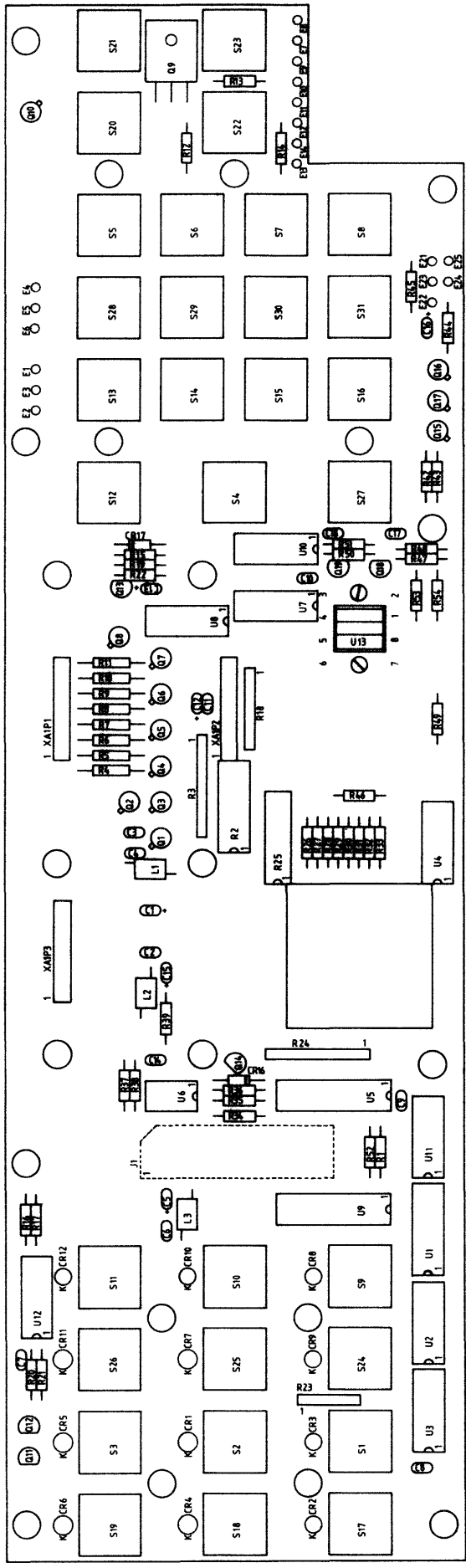

TITLE		FRONT PANEL CIRCUIT	
SIZE	CODE IDENT	DRAWING NO	
A1		44 85 91	
SCALE			SHEET 1 OF 1

1 2 3 4

ASSY 448591, FRONT PANEL CIRCUIT Schematic 4

- ⑨ Eight-bit output buffer, read by the microcomputer.

- ⑩ S1-S31, switches SPSTNO (Single Pole Single Throw Normally Open) with associated pull-up network and open-collector buffers.

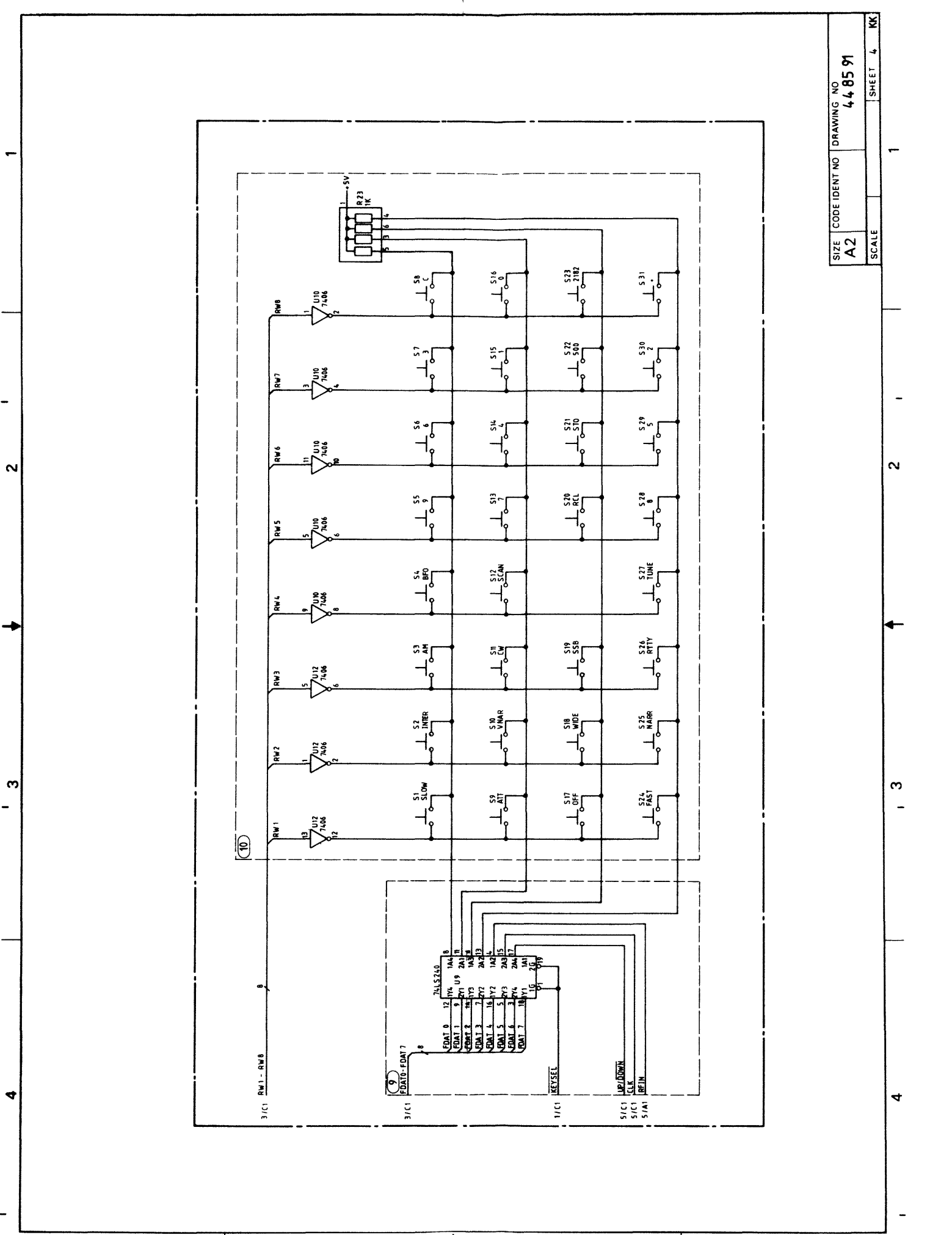

SIZE	CODE IDENT NO	DRAWING NO	
A2		44 85 91	
SCALE			SHEET 4 KK

1 2 3 4

D

C

B

A

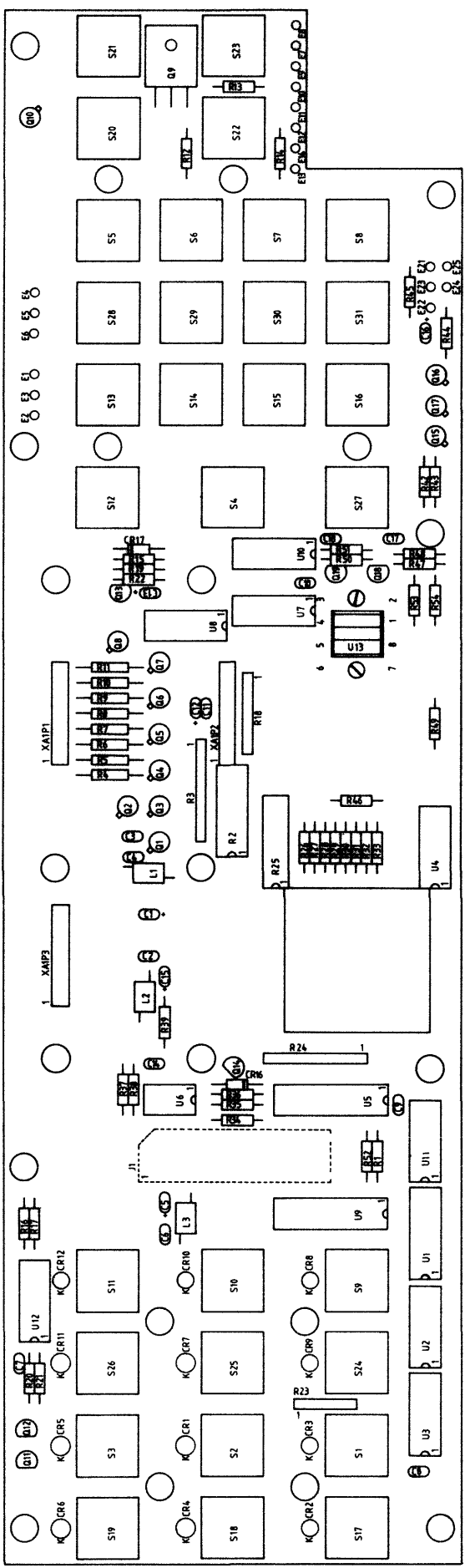

TITLE		FRONT PANEL CIRCUIT	
SIZE	CODE IDENT	DRAWING NO	
A1		44 85 91	
SCALE			SHEET 1 OF 1

1 2 3 4

⑪ Eight-bit Digital to Analog converter.

R24: pull-up network

R25-R33: R-2R network

U6b: Operational amplifier with an output range from 5V to 10V.

⑫ Input-circuit for inreading of tune adjustment.

U11a: is set when tuning down

U11b: is set when tuning up

When U11 has been read by the microcomputer, the program will clear U11a.

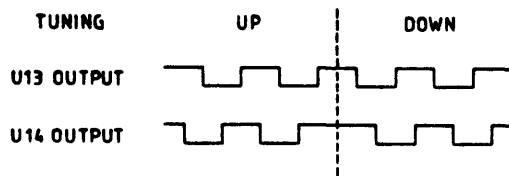

⑬ Sample hold circuit used as a source generator to the S-meter ⑭ and for A/D-conversion ⑮

⑭ S-meter with associated lamps.

⑮ Voltage comparator.

By means of the D/A-converter ⑪ and the comparator circuit an A/D-conversion of the RF-level is performed.

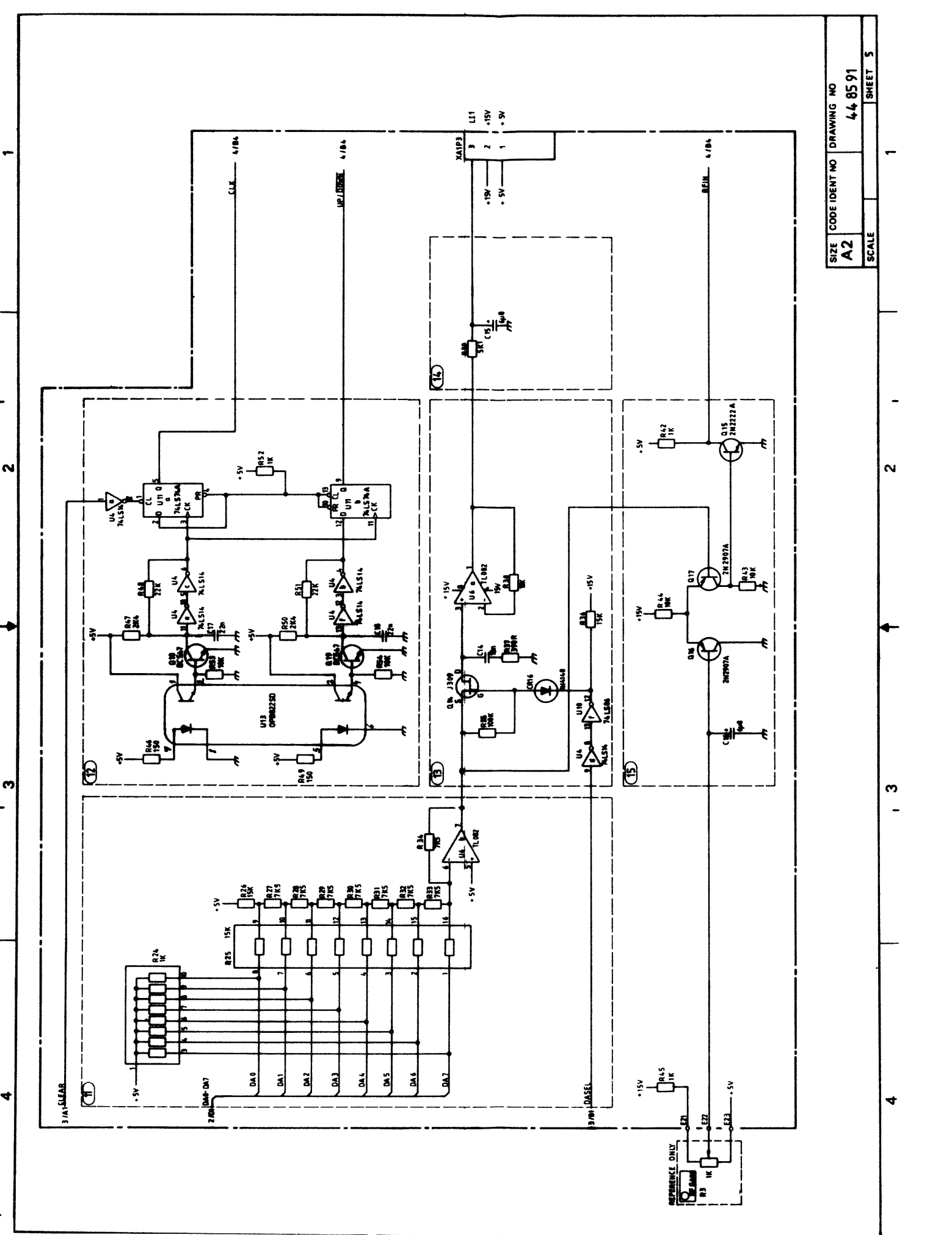

SIZE	CODE IDENT NO	DRAWING NO
A2		4-4 85 91
SCALE		SHEET 5

1 2 3 4

D

C

B

A

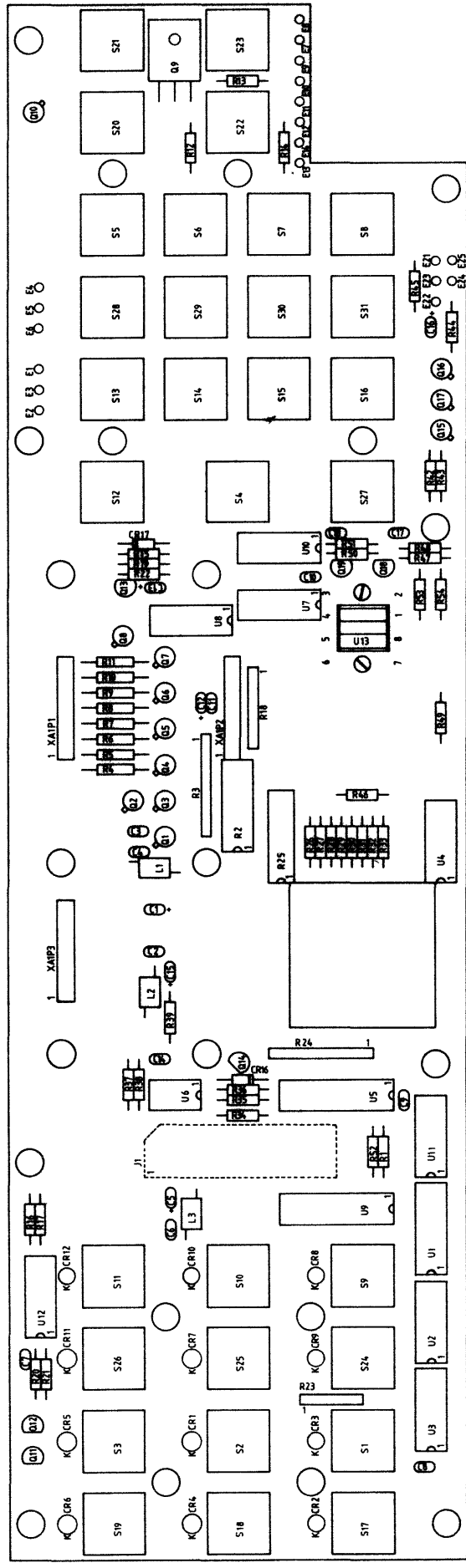

TITLE FRONT PANEL CIRCUIT

SIZE	CODE IDENT	DRAWING NO
A 1		44 85 91
SCALE		SHEET 1 OF 1

ASSY 448613, DISPLAY BOARD ASSEMBLY

- U1-U7 7-segment display.**
Most significant digit, U1.
- U8, U9 Light bars.**
- Q1-Q8 Drivers for multiplexing.**

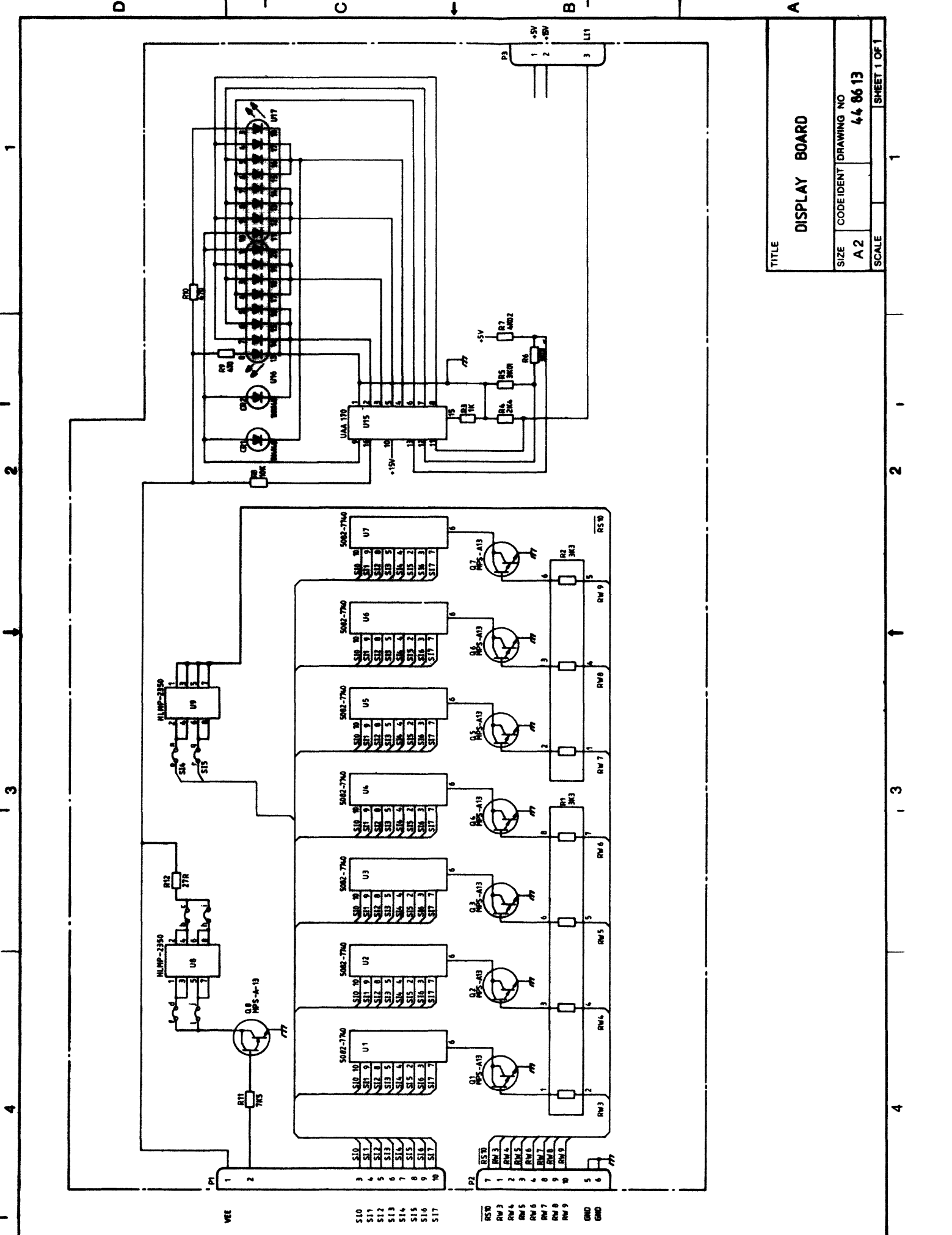

TITLE		DISPLAY BOARD	
SIZE	CODE IDENT	DRAWING NO	44 86 13
A 2			
SCALE			SHEET 1 OF 1

1. 4 3 2 1

D C B A

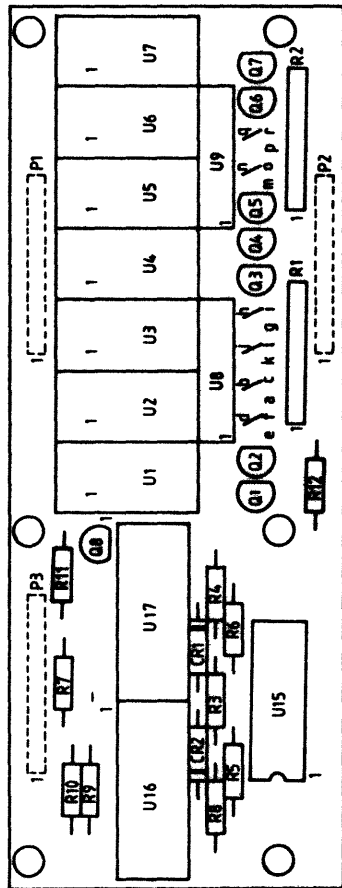

TITLE

DISPLAY BOARD

SIZE	CODE IDENT	DRAWING NO.	SHEET 1 OF 1
A 2		44 86 13	

1 2 3 4

ASSY 448648, MOTHERBOARD ASSEMBLY

To avoid noise in the more sensitive parts of the receiver, two buffers U1 and U2 separate the internal interface bus from the function bus. The internal interface bus is only activated when necessary.

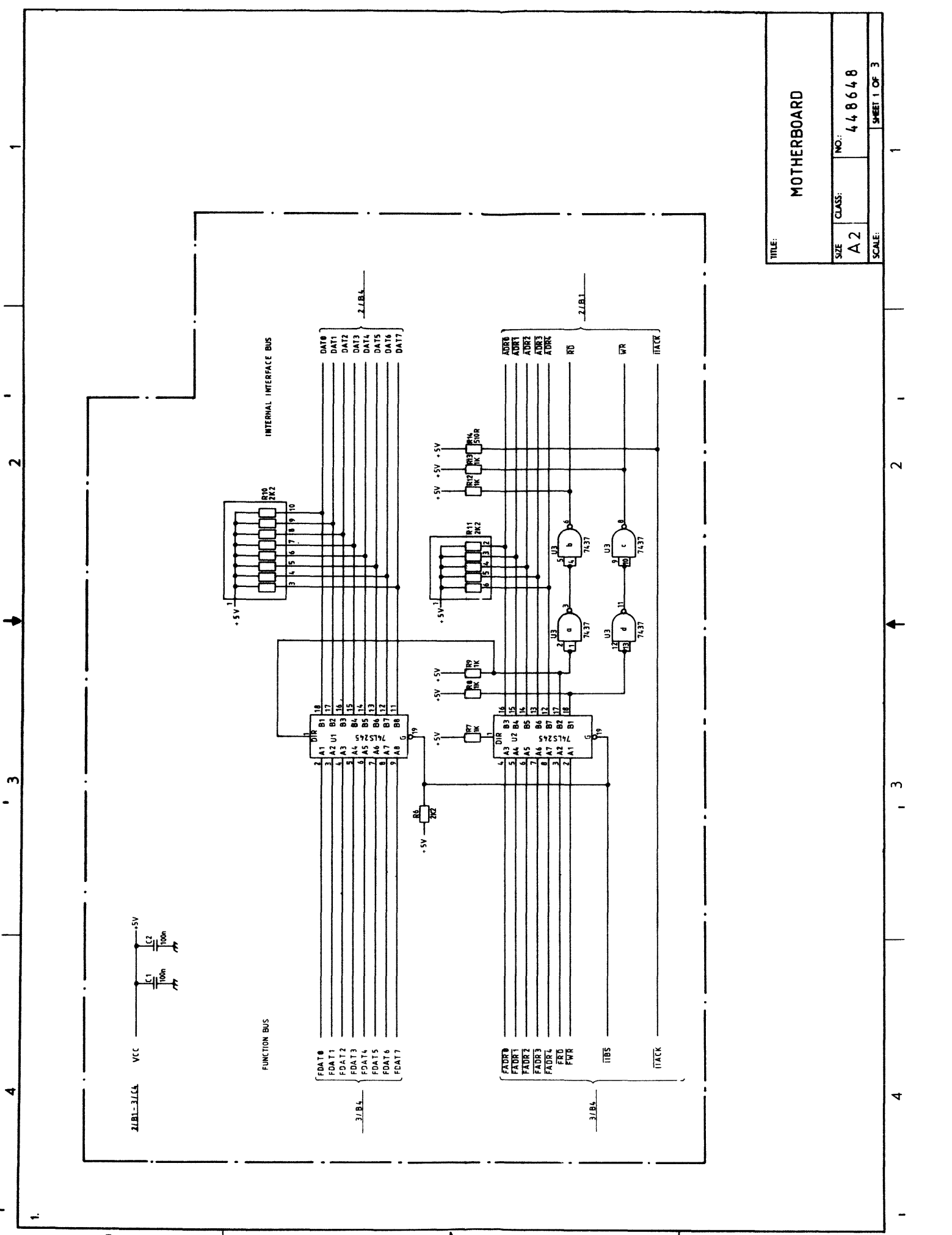

TITLE: MOTHERBOARD

SIZE CLASS: A2
 NO.: 448648

SCALE: SHEET 1 OF 3

A B C D

1 2 3 4

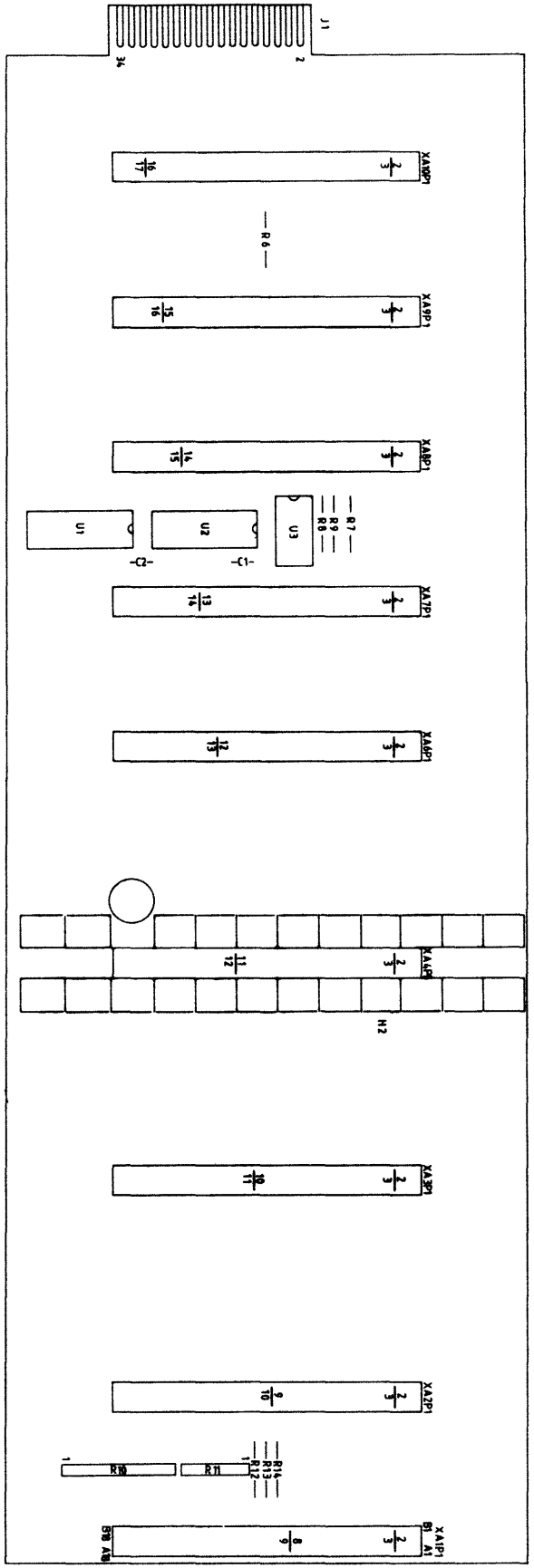

Codepin

TITLE		MOTHERBOARD	
SIZE	CODE IDENT	DRAWING NO	
A1		4, 8, 8, 8	
SCALE	SHEET 1 OF 1		

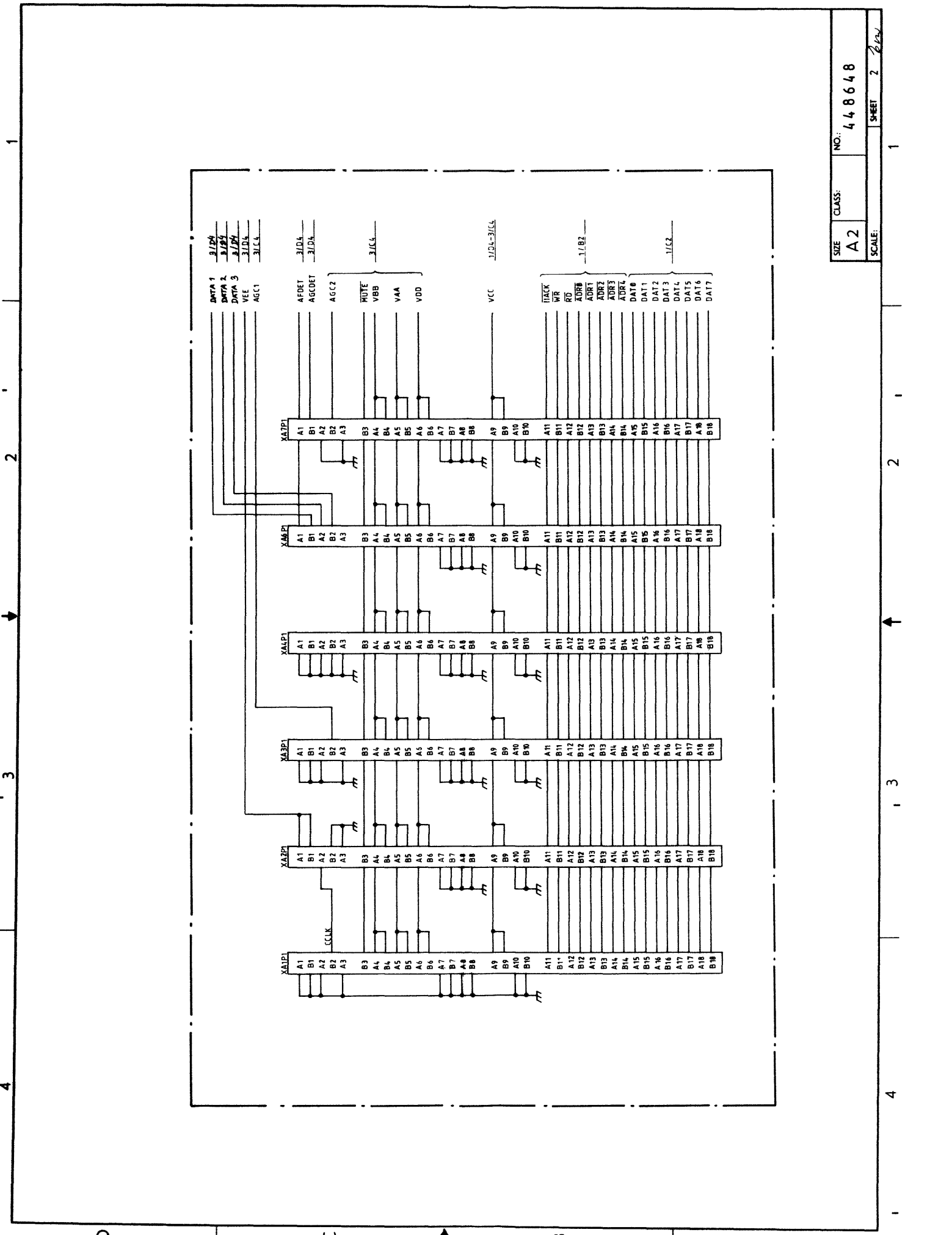

SIZE	CLASS:	NO.:
A2		448648
SCALE:		SHEET 2

1 2 3 4

D C B A

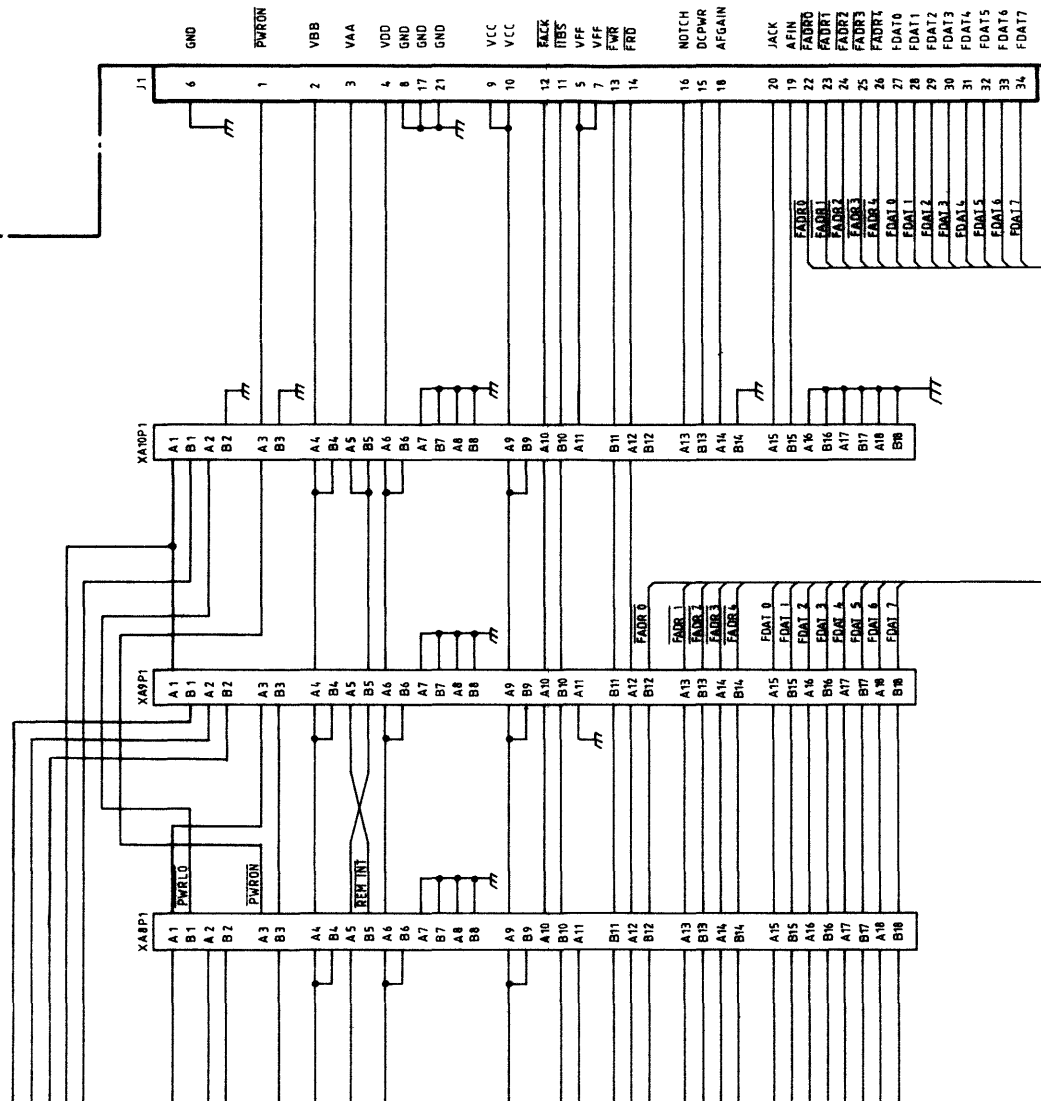
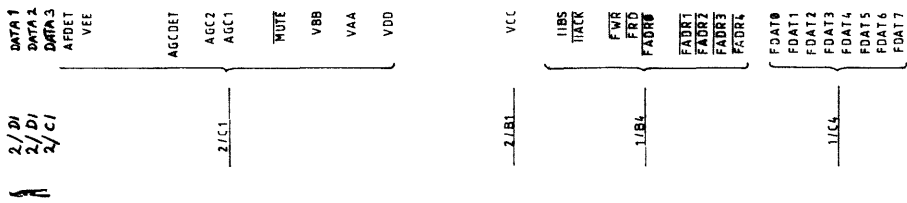

SIZE	CLASS	NO	448648
A2			
SCALE		SHEET 3	1

1 2 3 4

D C B A

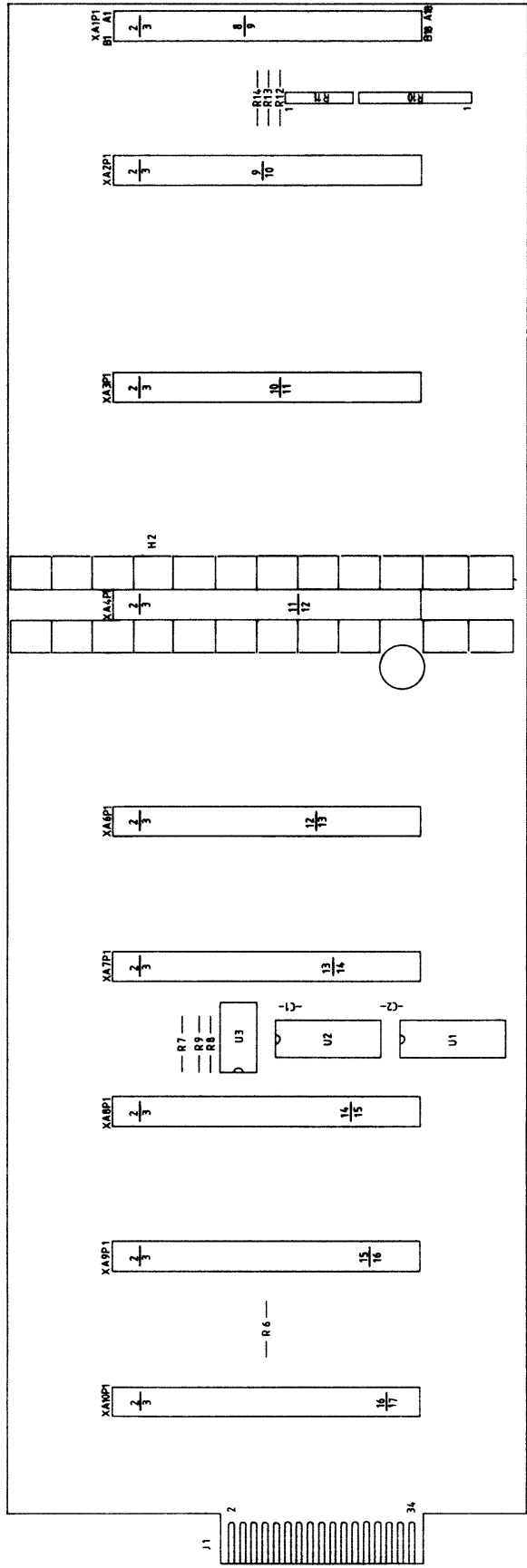

TITLE		MOTHERBOARD	
SIZE	CODE IDENT	DRAWING NO	
A1		448648	
SCALE			SHEET 1 OF 1