



MOTOROLA

intelligence everywhere™

MICOM-3F/3T/3R HF-SSB Transceivers



micom
best radio for worst events

Service Manual

6886859J01

COMMERCIAL WARRANTY (STANDARD)

Motorola radio communications products are warranted to be free from defects in material and workmanship for a period of ONE (1) YEAR, (except for crystals and channel elements which are warranted for a period of ten (10) years) from the date of shipment. Parts, including crystals and channel elements, will be replaced free of charge for the full warranty period but the labor to replace defective parts will only be provided for One Hundred-Twenty (120) days from the date of shipment. Thereafter purchaser must pay for the labor involved in repairing the product or replacing the parts at the prevailing rates together with any transportation charges to or from the place where warranty service is provided. This express warranty is extended by Motorola Communications and Electronics Inc., 1301 E. Algonquin Road, Schaumburg, Illinois 60196, to the original purchaser only, and only to those purchasing for purpose of leasing or solely for commercial, industrial, or governmental use.

THIS WARRANTY IS GIVEN IN LIEU OF ALL OTHER WARRANTIES EXPRESS OR IMPLIED WHICH ARE SPECIFICALLY EXCLUDED, INCLUDING WARRANTIES OF MERCHANTABILITY OR FITNESS FOR A PARTICULAR PURPOSE. IN NO EVENT SHALL MOTOROLA BE LIABLE FOR INCIDENTAL OR CONSEQUENTIAL DAMAGES TO THE FULL EXTENT SUCH MAY BE DISCLAIMED BY LAW.

In the event of a defect, malfunction or failure to conform to specifications established by Seller, or if appropriate, to specifications accepted by Seller in writing, during the period shown. Motorola, at its option, will either repair or replace the product or refund the purchase price thereof, and such action on the part of Motorola shall be the full extent of Motorola's liability hereunder.

This warranty is void if:

1. The product is used in other than its normal and customary manner.
2. The product has been subject to misuse, accident, neglect or damage.
3. Unauthorized alterations or repairs have been made, or unapproved parts used in the equipment.

This warranty extends only to individual products, batteries are excluded, but carry their own separate limited warranty. Because each radio system is unique, Motorola disclaims liability for range, coverage, or operation of the system as a whole under this warranty except by a separate written agreement signed by an officer of Motorola.

Non-Motorola manufactured products are excluded from this warranty, but subject to the warranty provided by their manufacturers, a copy of which will be supplied to you on specific written request.

To obtain performance of this warranty, purchaser must contact **mobat_support@mobatUSA.com**.

This warranty applies only within the United States.

COMPUTER SOFTWARE COPYRIGHTS

The Motorola products described in this instruction manual may include copyrighted Motorola computer programs stored in semiconductor memories or other media. Laws in the United States and other countries preserve for Motorola certain exclusive rights for copyrighted computer programs, including the exclusive right to copy or reproduce in any form the copyrighted computer program. Accordingly, any copyrighted Motorola computer programs contained in the Motorola products described in this instruction manual may not be copied or reproduced in any manner without the express written permission of Motorola. Furthermore, the purchase of Motorola products shall not be deemed to grant either directly or by implication, estoppel, or otherwise, any license under the copyrights, patents or patent applications of Motorola, except for the normal non-exclusive, royalty free license to use that arises by operation of law in the sale of a product.



MICOM-3F/3T/3R ***HF-SSB Transceivers***

© Motorola Inc., 2004
Motorola Inc.
Land Mobile Products Sector
1301 E. Algonquin Road
Schaumburg, IL 60196

Service Manual
Cat. No. 6886859J01

Table of Contents

	Page
Chapter 1 Introduction	1-1
1-1. Notational Conventions	1-1
1-2. Scope of this Manual	1-1
1-3. Federal Communication Commission Regulations	1-2
1-3.1 Compliance and Control Guidelines and Operating Instructions for Mobile Two-Way Radios Installed in Vehicles	1-2
1-3.2 Compliance and Control Guidelines and Operating Instructions for Mobile Two-Way Radios Installed as Fixed Site Control Stations	1-3
1-3.3 Electromagnetic Interference/Compatibility.....	1-3
1-3.4 Facilities	1-4
1-3.5 Vehicles.....	1-4
1-3.6 Driver Safety.....	1-4
1-3.7 When using your radio while driving, please:.....	1-4
1-3.8 Operational Warnings.....	1-4
1-3.9 Restrictions	1-5
1-4. Safe Handling of CMOS Devices.....	1-5
Chapter 2 Test Equipment & Spare Parts.....	2-1
2-1. Test Equipment.....	2-1
2-2. Spare Parts.....	2-2
Chapter 3 Disassembly & Reassembly.....	3-1
3-1. General	3-1
3-2. MICOM-3 Disassembly.....	3-2
3-2.1 Removing the Control Head	3-2
3-2.2 Removing the Cover (8).....	3-3
3-2.3 Removing the RF Shield (13).....	3-3
3-2.4 Removing the High Power Board (4).....	3-3
3-2.5 Control Head Disassembly.....	3-3
3-3. MICOM-3 Assembly	3-4
3-3.1 Control Head Assembly	3-4
3-3.2 High Power Board Assembly.....	3-4
3-3.3 LORD Board Assembly	3-5

	3-3.4 MICOM-3 Assembly	3-5
Chapter 4	Radio Tuning Procedure.....	4-1
4-1.	General	4-1
4-2.	Transmitter Calibration	4-1
4-3.	Power Calibration	4-1
4-4.	Oscillator Calibration	4-1
Chapter 5	Theory of Operation.....	5-1
5-1.	Introduction.....	5-1
5-2.	Transmitter	5-1
5-3.	Receiver	5-7
5-4.	Synthesizer	5-8
5-5.	Electronic Boards.....	5-10
	5-5.1 LORD Board.....	5-12
	5-5.2 High-Power Board.....	5-14
Chapter 6	Troubleshooting.....	6-1
6-1.	Overview.....	6-1
6-2.	Troubleshooting Charts.....	6-1
Chapter 7	Schematic Diagrams, Layouts and Parts Lists	7-1

Performance Specifications
MICOM-3F – Model M90AMNOKV5-K
MICOM-3T – Model M91AMNOKV5-K
MICOM-3R – Model M95AMNOKV5-K

General	<i>Transmit Frequency Range</i>	1.6 to 30 MHz
	<i>Receive Frequency Range</i>	0.1 to 30 MHz (0.1 to 1.6 MHz reduced performance)
	<i>RF Input Impedance</i>	50 Ω
	<i>Number of Channels</i>	200 simplex or half duplex, user programmable
	<i>Scanning</i>	5 groups with up to 100 channels per group, including 1 guard channel. Programmable scan rate: 1 to 5 sec. per channel, in 1 sec. steps
	<i>Frequency Stability</i>	0.6 ppm (0.1 ppm optional) @ -30° to 60°C
	<i>Frequency Drift (Aging)</i>	1 ppm/year
	<i>Synthesizer Lock Time</i>	10 msec. max.
	<i>Frequency Resolution</i>	10 Hz
	<i>Operating Temperature Range</i>	-30° to +60°C
	<i>Storage Temperature Range</i>	-40° to +85°C
	<i>Humidity</i>	Max. 95% @ 50°C
	<i>Remote Control Interface</i>	RS-232C (optional)
	<i>Modes of Operation</i>	<ul style="list-style-type: none"> • J3E SSB • R3E PILOT • H3E AME • J2ACW • J2B RTTY, ARQ, FEC, PACKET, MCW • B8C FAX, DATA, FSK
	<i>Operating Voltage</i>	13.8 VDC \pm 20%, negative ground
	<i>Dimensions</i>	
	<i>MICOM-3F</i>	92 H \times 302 W \times 270 D mm (3.7 H \times 11.9 W \times 10.7 D inch)
	<i>MICOM-3R</i>	92 H \times 302 W \times 285 D mm (3.7 H \times 11.9 W \times 11.3 D inch)
	<i>MICOM-3T</i>	92 H \times 302 W \times 285 D mm (3.7 H \times 11.9 W \times 11.3 D inch)

	<i>Weight</i>		
	<i>MICOM-3F</i>	5.7 kg (12.5 lb)	
	<i>MICOM-3R</i>	5.9 kg (13 lb)	
	<i>MICOM-3T</i>	5.8 kg (12.8 lb)	
	<i>ALE</i>	Per FED-STD-1045 and MIL-STD-188/141B	
Current Consumption @ 13.8 VDC	<i>Transmit</i>		
	<i>Voice (125 W P.E.P)</i>	14 A (see Note 2 on page vi)	
	<i>2 Tones (125 W P.E.P)</i>	23 A	
	<i>Single Tone</i>	28 A	
	<i>Receive</i>		
	<i>Full Audio</i>	3 A (see Note 2 on page vi)	
	<i>Squelch</i>	2.2 A (see Note 2 on page vi)	
FCC Information	<i>Transmitter Peak Envelope Power (P.E.P)</i>	125 W	
	<i>Frequency Range</i>	1.6 to 30 MHz	
	<i>Emissions Authorized</i>	J3E, R3E, H3E, J2A, J2B, B8C	
	<i>Applicable Parts of FCC Rules</i>	15, 80, 90	
	<i>FCC Type Acceptance Number</i>		
	<i>Standard for Stability</i>	ABZ9QCC1635	
	<i>0.1 ppm High Stability Option</i>	ABZ9QCC1634	
Military and Industrial Standards	<i>Vibration</i>	US MIL-STD 810C	Method 514.2
		US MIL-STD 810D	514.3
		US MIL-STD 810E	514.4
	<i>Shock</i>	US MIL-STD 810C	Method 516.2
		US MIL-STD 810D	516.3
		US MIL-STD 810E	516.4
	<i>Rain</i>	US MIL-STD 810C	Method 506.1
		US MIL-STD 810D	506.2
		US MIL-STD 810E	506.3
	<i>Dust</i>	US MIL-STD 810C	Method 510.1
		US MIL-STD 810D	510.2
		US MIL-STD 810E	510.3
	<i>Salt Fog</i>	US MIL-STD 810C	Method 509.1
		US MIL-STD 810D	509.2
		US MIL-STD 810E	509.3

The MICOM-3 also meets the EIA-RS152B for shock, vibration and applicable test procedures, US FCC for channel occupancy, spurious, interference and frequency tolerance. It is manufactured according to the demanding standards of ISO 900 and EMC (Electromagnetic Compatibility).

Transmitter	<i>Output Power</i>	125 W P.E.P and average
	<i>Reduced Power Levels</i>	25 W, 62 W, 100 W (RSS programmable)
	<i>Audio Bandwidth</i>	
	<i>Voice</i>	350 to 2700 Hz at -6 dB
	<i>CW</i>	650 to 1150 Hz
	<i>Low Speed Data</i>	1450 to 1950 Hz
	<i>High Speed Data</i>	350 to 3300 Hz (see Note 2 on page vi)
	<i>Audio Bandwidth Ripple</i>	3 dB
	<i>Intermodulation</i>	<ul style="list-style-type: none"> • -31 dB/P.E.P • -35 dB/P.E.P typical (see Note 1 on page vi)
	<i>Harmonic Emissions</i>	<ul style="list-style-type: none"> • -64 dB/P.E.P • -70 dB/P.E.P typical (see Note 1 on page vi)
	<i>Spurious Emissions</i>	<ul style="list-style-type: none"> • -64 dB/P.E.P • -70 dB/P.E.P typical (see Note 1 on page vi)
	<i>Carrier Suppression</i>	-50 dB/P.E.P
	<i>Undesired Sideband Suppression</i>	-55 dB/P.E.P
	<i>Audio Distortion</i>	2.5%
	<i>1/2 Power Microphone Sensitivity</i>	25 to 125mV (RMS)/600 Ω
	<i>Hum & Ripple</i>	-50 dB
	<i>Inband Noise</i>	-60 dB (30 Hz BW)
	<i>TX/RX Switching Time</i>	10 msec
	<i>Tx Tuning Adjustments</i>	None
	Receiver	<i>Sensitivity (SINAD) SSB</i>
<i>1/2 Rated Power Sensitivity</i>		1 μV for 2.5W audio at speaker
<i>Selectivity</i>		-6 dB @ 350 to 2700 Hz -60 dB @-1 kHz; +4 kHz
<i>Image Rejection</i>		-80 dB
<i>IF Rejection</i>		-85 dB
<i>Undesired Sideband Rejection</i>		-55 dB @ -1 kHz
<i>Spurious</i>		-80 dB
<i>Intermodulation</i>		-80 dB
<i>Crossmodulation</i>		-100 dB @ 100 kHz
<i>Desensitization</i>		-100 dB @ 100 kHz

<i>Reciprocal Mixing</i>	-100 dB @ 100 kHz
<i>Audio Power at Speaker</i>	5W @ 2.5% distortion
<i>RGC Range</i>	5 μ V to 1V (2 dB change in output level)
<i>RGC Time Constants</i>	
<i>Voice</i>	Attack time 10 msec Release time 1500 msec
<i>Data</i>	Attack time 10 msec Release time 10 msec
<i>Squelch</i>	Constant SINAD (digital)
<i>Clarifier Range</i>	\pm 200 Hz in 10 Hz steps (see Note 2 on page vi)
<i>Receiver Tuning Adjustments</i>	None
<i>Preselector Sections</i>	Sub-octave (1.6 MHz to 30 MHz range)
<i>Maximum Antenna Input</i>	20 kV transient, 100V RMS for 2 minutes

Controls Standard and optional: Volume, on/off, scroll, squelch, scan, USB/LSB, call, monitor, priority, function and accessory/programming connector

Note 1: Values noted as "Typical" are valid over 90% or more of the frequency range.

Note 2: Optional for authorized dealers only.

Specifications subject to change without notice.

MICOM-3F Model Complements

FKN4345A	DC Cable
FLN2776A	Control Head Assembly
FTN6069A	Control Head Board
FLN2774A	High Power Assembly
FTN6068A	High Power Board
FLN2773A	Low RF Assembly
FTN6067A	Low RF Board
FMN1615A	Microphone MICOM-3
FHN5910A	MICOM-3 Microphone Module
HMN3596A	GM300 Microphone Kit
6802941C60	MICOM-3 Owner's Manual

Operating Options

G424	Add	PC Control and Programming Software Package
S135	Enhanced	Digital Noise Blanker (recommended for mobile installations)
G112	Enhanced	High frequency stability option (0.1 ppm)
S809	Enhanced	Interface cable kit for CW key & headphones (Note 1)
G469	Enhanced	24VDC Operation (DC/DC converter)
G419	Enhanced	USB COM port for connecting external keyboard
G423	Add	ALE DTM/DBM (data transfer message/data block message)
G421	Add	Internal GPS Receiver with polling application
G849		Interface option for external secure voice device (VP-116)

Mobile Station Accessories

FAD1410	Automatic Tuning Whip Antenna
	or
F2265	Automatic Antenna Tuner
	1.6-30 MHz, lightweight, compact housing, includes 17 foot (5.2 m) RF cable and instruction manual
FAD1400	12 ft Whip Antenna (not required with FAD1410)
FLN2272	Mobile Mounting Kit
FSN1600	External Speaker Assembly

Fixed Station Operating Options (Note 2)

S71	Delete	Delete hand microphone
S308	Add	Phone patch interface cable kit, radio to phone patch (Note 1)
G561	Add	Interface cable for MICOM Link unit

Fixed Station Accessories

FMN1614	Desk microphone
FLN2271	Junction box for connecting up to 4 accessories in addition to CW key and headphones (Note 1)
FLN2294	Package kit for continuous duty data transmission. Includes FLN2271 junction box
FPN5590	AC Power supply with autoswitching for 110/220VAC

Service Manuals

6886859J01	MICOM-3F/3T/3R Service Manual
6886862J01	Service manual for MICOM-RM1000 1kW linear amplifier

Field Retrofit Kits

FLN2515	Interface cable kit for CW key & Headphones
FLN2517	Interface cable kit for Phone patch unit
FLN2530	Interface cable for MICOM Link unit
FLN2539	24VDC Operation (DC/DC converter)
FVN4841	PC Control and Programming Software Package

Remote Control Application Option

G420	2-wire Remote Control Head (up to 5 km)
------	---

1 kW Linear Amplifier

FLN3175	MICOM-RM1000 1 kW Linear Amplifier Unit (require option G156 interface cable option)
---------	--

Spare Boards Kit

FEN1672	Recommended Spare Boards Kit for MICOM-3F
---------	---

4 Year Extended Warranty

FRN8465

4 Year Warranty for MICOM-3F

Note 1: The MICOM-3 includes one accessory port for connecting one accessory device (phone patch, deskset, ARQ/RTTY modem, fax modem, computer, or headphones). If the simultaneous connection of two or more (up to 4 plus CW & headphones) devices to the accessory port is required, order FLN2271 junction box listed in this page. The FLN2271 is included with FLN2294 package kit.

Note 2: For Fixed Station Operation, order S71 (delete palm microphone), FMN1614 desk microphone and F2369 AC power supply/charger.

MICOM-3T Model Complements

FKN4345A	DC Cable
FLN2775A	Control Head Assembly
FTN6070A	Control Head Board
FLN3173A	High Power Assembly
FTN6068A	High Power Board
FLN2773A	Low RF Assembly
FTN6067A	Low RF Board
FMN1615A	Microphone MICOM-3
FHN591UA	MICOM-3 Microphone Module
HMN3596A	GM300 Microphone Kit
6886867J01	MICOM-3F/3T/3T Owner's Guide

Operating Options

G424	Add	PC Control and Programming Software Package
G112	Enhanced	High frequency stability option (0.1 ppm)
S809	Enhanced	Interface cable kit for CW key & headphones (Note 1)
G469	Enhanced	24VDC Operation (DC/DC converter)
G419	Enhanced	USB COM port for connecting external keyboard
G423	Add	ALE DTM/DBM (data transfer message/data block message)
G421	Add	Internal GPS Receiver with polling application
G849		Interface option for external secure voice device (VP-116)

Mobile Station Accessories

FAD1410	Automatic Tuning Whip Antenna
	or
F2265	Automatic Antenna Tuner
	1.6-30 MHz, lightweight, compact housing, includes 17 foot (5.2 m) RF cable and instruction manual
FAD1400	12 ft Whip Antenna (not required with FAD1410)
FLN2272	Mobile Mounting Kit
FSN1600	External Speaker Assembly

Fixed Station Operating Options (Note)

S71	Delete	Delete hand microphone
S308	Add	Phone patch interface cable kit, radio to phone patch (Note 1)
G561	Add	Interface cable for MICOM Link unit

Fixed Station Accessories

FMN1614	Desk microphone
FLN2271	Junction box for connecting up to 4 accessories in addition to CW key and headphones (Note 1)
FLN2294	Package kit for continuous duty data transmission. Includes FLN2271 junction box
FPN5590	AC Power Supply with Autoswitching for 110/220 VAC

Service Manuals

6886859J01	MICOM-3F/3T/3R Service Manual
------------	-------------------------------

Field Retrofit Kits

FLN2515	Interface cable kit for CW key & headphones (Note)
FLN2517	Interface cable kit for phone patch unit (Note)
FLN2530	Interface cable for MICOM Link unit
FLN2539	24VDC Operation (DC/DC converter)

Spare Boards Kit

FEN1673	Recommended Spare Boards Kit for MICOM-3T
---------	---

4 Year Extended Warranty

FRN8466	4 Year Warranty for MICOM-3T
---------	------------------------------

Note: The MICOM-3T includes one accessory port for connecting one accessory device (phone patch, deskset, ARQ/RTTY modem, fax modem, computer, or headphones). If the simultaneous connection of two or more (up to 4 plus CW & Headphones) devices to the accessory port is required, order FLN2271 junction box listed in this page. The FLN2271 is included with FLN2294 package kit.

MICOM-3R Model Complements

FKN4345A	DC Cable
FLN2777A	Control Head Assembly
FTN6069A	Control Head Board
FLN3174A	High Power Assembly
FTN6068A	High Power Board
FLN2773A	Low RF Assembly
FTN6067A	Low RF Board
6886867J01	MICOM-3F/3T/3R Owner's Guide

Operating Options

G424	Add	PC Control and Programming Software Package
G112	Enhanced	High frequency stability option (0.1 ppm)
S809	Enhanced	Interface cable kit for CW key & headphones (Note 1)
G469	Enhanced	24VDC Operation (DC/DC converter)
G419	Enhanced	USB COM port for connecting external keyboard
G423	Add	ALE DTM/DBM (data transfer message/data block message)
G421	Add	Internal GPS Receiver with polling application
G849		Interface option for external secure voice device (VP-116)

Mobile Station Accessories

FLN2537	Automatic Antenna Tuner 1.6 to 30 MHz, lightweight, compact housing, includes 17 foot (5.2 m) RF cable and instruction manual
FLN2538	Mobile Mounting Kit

Fixed Station Operating Options

S308	Phone patch interface cable kit, radio to phone patch (Note 1)
G561	Interface cable for MICOM Link unit

Military Type Audio Accessories

FMN5501	Military type Handset (H-250/U)
FSN5503	Military type External Speaker (LS-454/U)

Fixed Station Accessories (Note)

FLN2271	Junction box for connecting up to 4 accessories in addition to CW key and headphones
FLN2294	Package kit for continuous duty data transmission. Includes FLN2271 junction box
FPN5590	AC Power supply with autoswitching for 110/220VAC

Service Manuals

6886859J01	MICOM-3F/3T/3R Service Manual
------------	-------------------------------

Field Retrofit Kits

FKN4403	Interface cable kit for CW key & headphones (Note)
FKN4404	Interface cable kit for phone patch unit (Note)
FKN4405	Interface cable kit for fax modem (Note)
FKN4406	Interface cable kit for RTTY/ARQ modem (Note)
FLN2273	Spare RSS software package (Note)

Remote Control Application Option

G420	2-wire Remote Control Head (up to 5 km)
------	---

Spare Boards Kit

FEN1674	Recommended Spare Boards Kit for MICOM-3R
FEN1678	Recommended Spare Module Package for MICOM-RM1000 1 kW Linear Amplifier

4 Year Extended Warranty

FRN8467	4 Year Warranty for MICOM-3R
FRN8470	4 Year Warranty for MICOM-RM1000 1 kW Linear Amplifier

Note: The MICOM-3R includes one accessory port for connecting one accessory device (phone patch, deskset, ARQ/RTTY modem, fax modem, computer, or headphones). If the simultaneous connection of two or more (up to 4 plus CW & Headphones) devices to the accessory port is required, order FLN2271 junction box listed in this page. The FLN2271 is included with FLN2294 package kit.

Related Publications Available Separately

The following documents offer additional information:

6886867J01 MICOM-3F/3T/3T Owner's Guide

68P02942CSD MICOM-3 HF-SSB Transceiver, 1.6-30 MHz, 125 W P.E.P and Average,
Radio Service Software, User's Guide

Chapter 1

Introduction

1-1. Notational Conventions

Throughout the text in this publication, you will notice the use of warnings, cautions and notes. These notations are used to emphasize that safety hazard exist, and care must be taken and observed.



Warning

This Warning symbol denotes a hazard. It calls attention to a procedure or practice that could result in personal injury if not performed correctly.

Caution

The Caution symbol denotes a hazard. It calls attention to a procedure or practice that could result in damage to or destruction of part or all of the product if not performed correctly.

Note

An operational procedure, practice or condition, etc., which is essential to emphasize.

Throughout this manual, MICOM-3F, MICOM-3T and MICOM-3R are referred to as MICOM-3.

1-2. Scope of this Manual

This manual includes model/kit information, specifications, disassembly/reassembly procedures, alignment, troubleshooting, and all theory, schematic diagrams, printed circuit board details and parts lists for all parts in the equipment described.

Caution

This manual is intended for use by experienced technicians who are familiar with similar types of equipment.

1-3. Federal Communication Commission Regulations

The FCC has established limits for safe exposure to radio frequency (RF) emissions from mobile two-way radios. The FCC requires manufacturers to demonstrate compliance with RF exposure limits before mobile two-way radios can be marketed in the U.S. When two-way radios are approved for occupational/controlled environment exposure limits, the FCC requires users to be fully aware of, and exercise control over, their exposure. Awareness and control of RF exposure can be accomplished by education or training through appropriate means such as information and instructions in user manuals or safety booklets, or other appropriate means. This user safety booklet includes useful information about RF exposure and helpful instructions on how to control your RF exposure.

Your Motorola two-way radio is designed and tested to comply with a number of national and international standards and guidelines (listed below) regarding human exposure to radio frequency electromagnetic energy. **This radio complies with the IEEE (FCC) and ICNIRP exposure limits for occupational/controlled RF exposure environments at usage factors of up to 50% talk-50% listen.** In terms of measuring RF energy for compliance with FCC exposure guidelines, **your radio radiates measurable RF energy only while it is transmitting (during talking), not when it is receiving (listening) or in standby mode.**

Your Motorola two-way radio complies with the following RF energy exposure standards and guidelines:

- United States Federal Communications Commission, Code of Federal Regulations; 47CFR part 2 sub-part J
- American National Standards Institute (ANSI) / Institute of Electrical and Electronic Engineers (IEEE) C95.1-1992
- Institute of Electrical and Electronic Engineers (IEEE) C95.1-1999 Edition
- International Commission on Non-Ionizing Radiation Protection (ICNIRP) 1998
- Ministry of Health (Canada) Safety Code 6: Limits of Human Exposure to Radiofrequency Electromagnetic Fields in the Frequency Range from 3 kHz to 300 GHz, 1999
- Australian Communications Authority Radiocommunications (Electromagnetic Radiation – Human Exposure) Standard, 2001
- ANATEL, Brasil Regulatory Authority, Resolution 256 (April 11, 2001: Additional Requirements for SMR, Cellular and PCS Product Certification.

1-3.1 Compliance and Control Guidelines and Operating Instructions for Mobile Two-Way Radios Installed in Vehicles

To control your exposure and ensure compliance with the occupational/ controlled environment exposure limits, always adhere to the following procedures:

- **To transmit (talk), push the Push-To-Talk (PTT) button; to receive, release the PTT button.**

Transmit only when people outside the vehicle are at least the minimum lateral distance away (as shown in table below) from a properly installed, externally-mounted antenna.

The table below lists the minimum lateral distance for bystanders in an uncontrolled environment from the transmitting antenna at several different ranges of rated radio power for mobile radios installed in a vehicle.

Rated Power of Vehicle-Installed Mobile Two-Way Radio	Minimum Lateral Distance from Transmitting Antenna
Less than 7 watts	8 inches (20 centimeters)
7 to 15 watts	1 foot (30 centimeters)
16 to 50 watts	2 feet (60 centimeters)
51 to 110 watts	3 feet (90 centimeters)

- **Install mobile antennas at the center of the roof or the center of the trunk deck per specific guidelines and instructions in the Radio Installation Manual. These mobile antenna installation guidelines are limited to metal body vehicles.**

Use only the Motorola-approved, supplied antenna or a Motorola- approved replacement antenna. Use of non-Motorola-approved antennas, modifications, or attachments could damage the radio and may violate FCC regulations.

- **For a list of Motorola-approved antennas, visit the following web site: <http://www.motorola.com/cqjss/index.shtml>.**

For additional information on exposure requirements or other training information, visit <http://www.motorola.com/rfhealth>.

1-3.2 Compliance and Control Guidelines and Operating Instructions for Mobile Two-Way Radios Installed as Fixed Site Control Stations

If mobile radio equipment is installed at a fixed location and operated as a control station or as a fixed unit, the antenna installation must comply with the following requirements in order to ensure optimal performance and compliance with the RF energy exposure limits in the standards and guidelines listed in the Federal Communication Commission Regulations section.

- The antenna should be mounted outside the building on the roof or a tower if at all possible.
- As with all fixed site antenna installations, it is the responsibility of the licensee to manage the site in accordance with applicable regulatory requirements and may require additional compliance actions such as site survey measurements, signage, and site access restrictions in order to ensure that exposure limits are not exceeded.

1-3.3 Electromagnetic Interference/Compatibility

Note *Nearly every electronic device is susceptible to electromagnetic interference (EMI) if inadequately shielded, designed, or otherwise configured for electromagnetic compatibility. It may be necessary to conduct compatibility testing to determine if any electronic equipment used in or around vehicles or near fixed site antenna is sensitive to external RF energy or if any procedures need to be followed to eliminate or mitigate the potential for interaction between the radio transmitter and the equipment or device.*

1-3.4 Facilities

To avoid electromagnetic interference and/or compatibility conflicts, **turn off your radio in any facility where posted notices instruct you to do so.** Hospitals or health care facilities may be using equipment that is sensitive to external RF energy.

1-3.5 Vehicles

To avoid possible interaction between the radio transmitter and any vehicle electronic control modules, for example, ABS, engine, or transmission controls, the radio should be installed only by an experienced installer and that the following precautions be used when installing the radio:

1. Refer to the manufacturer's instructions or other technical bulletins for recommendations on radio installation.
2. Before installing the radio, determine the location of the electronic control modules and their harnesses in the vehicle.
3. Route all radio wiring, including the antenna transmission line, as far away as possible from the electronic control units and associated wiring.

1-3.6 Driver Safety

Check the laws and regulations on the use of radios in the area where you drive. Always obey them.

1-3.7 When using your radio while driving, please:

- Give full attention to driving and to the road.
- Pull off the road and park before making or answering a call if driving conditions so require.

1-3.8 Operational Warnings



For Vehicles with an Air Bag

Do not mount or place a mobile radio in the area over an air bag deployment area. Air bags inflate with great force. If a radio is placed in the air bag deployment area and the air bag inflates, the radio may be propelled with great force and cause serious injury to occupants of the vehicle.

Potentially Explosive Atmospheres

Turn off your radio prior to entering any area with a potentially explosive atmosphere. Sparks in a potentially explosive atmosphere can cause an explosion or fire resulting in bodily injury or even death.

The areas with potentially explosive atmospheres include fueling areas such as below decks on boats, fuel or chemical transfer or storage facilities, and areas where the air contains chemicals or particles such as grain, dust or metal powders. Areas with potentially explosive atmospheres are often, but not always, posted.



Blasting Caps and Blasting Areas

To avoid possible interference with blasting operations, turn off warning your radio when you are near electrical blasting caps, in a blasting area, or in areas posted: "Turn off two-way radio". Obey all signs and instructions.

For radios installed in vehicles fueled by liquefied petroleum gas, refer to the (U.S.) National Fire Protection Association standard, NFPA 58, for storage, handling, and/or container information. For a copy of the LP-gas standard, NFPA 58, contact the National Fire Protection Association, One Battery Park, Quincy, MA.

1-3.9 Restrictions

Because this radio contains a transmitter, federal law prohibits unauthorized, non-licensed personnel from adjusting or maintaining it. If any operational difficulties should arise while using this product, report them to authorized service personnel as soon as possible.



Do not attempt any unauthorized modification to the radio.

1-4. Safe Handling of CMOS Devices

Complementary metal-oxide semiconductor (CMOS) devices are used in this family of radios. While the attributes of CMOS are many, their characteristics make them susceptible to damage by electrostatic or high voltage charges. Damage can be latent, resulting in failures occurring weeks or months later. Therefore, special precautions must be taken to prevent device damage during disassembly, troubleshooting, and repair. Handling precautions are mandatory for CMOS circuits and are especially important in low humidity conditions.

Caution Do not attempt to disassemble the radio without observing the following handling precautions.

1. Eliminate static generators (plastics, styrofoam, etc.) in the work area.
2. Remove nylon or double-knit polyester jackets, roll up long sleeves, and remove or tie back loose hanging neckties.
3. Store and transport all static-sensitive devices in ESD protective containers.
4. If at all possible, handle CMOS devices by the package and not by the leads. Prior to touching the unit, touch an electrical ground to remove any static charge that you may have accumulated. The package and substrate may be electrically common. If so, the reaction of a discharge to the case would cause the same damage as touching the leads.
5. Disconnect all power from the unit before ESD sensitive components are removed or inserted, unless otherwise noted.

6. Use a static safeguarded workstation, which can be accomplished through the use of an anti-static kit (for example, Motorola part number 0180386A82). This kit includes a wrist strap, two ground cords, a static-control table mat and a static-control floor mat.

When these items are not readily available, observing the following techniques will minimize chance of damage:

- If a static-sensitive device is to be temporarily set down, use a conductive surface for placement of the device.
 - Make skin contact with a conductive work surface first and maintain this contact when the device is set down or picked up.
7. Always wear a conductive strap when servicing this equipment. The Motorola part number for a replacement wrist strap that connects to the table mat is 42-80385A58.
 8. When straightening CMOS pins, provide ground straps for apparatus used.
 9. When soldering, use a grounded soldering iron.

Chapter 2

Test Equipment & Spare Parts

2-1. Test Equipment

The list in Table 2-1 includes the standard test equipment required for servicing the MICOM-3 radios.

Table 2-1. Test Equipment

Model No.	Description	Comments
R2670	Motorola Communication Analyzer	
HP 8904A	Multi-function Synthesizer	
Pentium 3 or Better	Personal Computer	

2-2. Spare Parts

The lists in Table 2-2 to Table 2-5 include all the recommended spare part kits and components.

Note The spare parts marked with an asterisk in Table 2-2 to Table 2-5 are plant items.

Table 2-2. Spare Parts Common to All MICOM-3 Models

Manufacturer Kit/Part Number	Description
FTN6067A (for standard radio with 0.6 ppm frequency stability)	Low RF and Digital (LORD) board
FTN6068A	High Power board
0102701K52	Harmonic Filter module
4808115L07	PIN diode
2409646B25	Coil, 100 μ Hy
4808020K01	Final stage transistor ($\times 2$)
4808020K02	Driver transistor ($\times 2$)
FRN4345	DC cable
6500020986	Fuse, 30A
6500086099	Fuse, 7.5A
0102701K51	Flat cable (from Control Head to LORD board)
0102700K23	Flat cable (from High-Power to LORD board)
0102700K22	Internal coax
0102703K64	Battery assembly
FMN1615	Microphone

Table 2-3. Spare Parts for MICOM-3F – Model M90AMNOKV5-K

Manufacturer Kit/Part Number	Description
FLN2776A	Control Head Assembly
*20724811000	Front Panel
*20724821000	Window
*20722111400	LCD
*20724823000	Keypad
*20724822000	Left keypad
3608147K01	Volume knob, interior
3605422W02	Volume knob, exterior
5008351Y01	Speaker
3280603K01	Gasket, speaker
3204071P02	Gasket, panel
*20724812000	Set cables
FTN6069A	Control Head board
2802101U01	Zebra connector for LCD
2802102U01	Zebra connector for LCD

Table 2-4. Spare Parts for MICOM-3T – Model M91AMNOKV5-K

Manufacturer Kit/Part Number	Description
HKN6098A	Remote cable
3286211C01	Gasket, remote panel
FLN2775A	Control Head Assembly
*20724811000	Front panel
*20724814000	Back panel
*20724821000	Window
*20722111400	LCD
*20724823000	Keypad
*20724822000	Left keypad
3608147K01	Volume knob, interior
3605422W02	Volume knob, exterior
5008351Y01	Speaker
3286212C01	Gasket, board to panel
*20724812000	Set cables
FTN6070A	Control Head board
2802101U01	Zebra connector for LCD
2802102U01	Zebra connector for LCD
FRN5885	Interface board
0102705K85	Ground cable
0102701K51	Flat cable

Table 2-5. Spare Parts for MICOM-3R – Model M95AMNOKV5-K

Manufacturer Kit/Part Number	Description
FLN2777A	Control Head Assembly
*20724812000	Front Panel
*20724821000	Window
*20722111400	LCD
*20724823000	Keypad
*20724822000	Left keypad
3686525F01	Volume knob
0102706K34	Speaker
3286532F01	Gasket, speaker
3280605K05	Gasket, panel
*20724812000	Set cables
FTN6069A	Control Head board
2802101U01	Zebra connector for LCD

Intentionally Left Blank

Chapter 3

Disassembly & Reassembly

3-1. General

The following sections provides disassembly and reassembly instructions for MICOM-3.

When tightening screws, apply controlled torques in accordance with Table 3-1. The allowed torque tolerance is $\pm 10\%$.

Table 3-1. Tightening Torque for Metric System Screws

Screw Size (millimeter)	Thread Forming Metallic Surface	Threaded Metallic Surface	Plastic Surface
M3	10 kgf/cm	10 kgf/cm	6 kgf/cm
M4	15 kgf/cm	15 kgf/cm	7 kgf/cm
M5, M6	22 kgf/cm	18 kgf/cm	8 kgf/cm

Table 3-2. Tightening Torque for American System Screws

Screw Size (inch)	Thread Forming Metallic Surface	Threaded Metallic Surface	Plastic Surface
4-40	10 kgf/cm	7 kgf/cm	6 kgf/cm
6-32	15 kgf/cm	15 kgf/cm	7 kgf/cm
8-32, 10-32	22 kgf/cm	18 kgf/cm	8 kgf/cm

3-2. MICOM-3 Disassembly

Note The numbers in parentheses refer the subassembly or component number in the MICOM-3 or Control Head exploded views at the end of this manual.

3-2.1 Removing the Control Head

3-2.1.1 Removing the MICOM-3F Control Head

1. Insert a small flat blade screw driver, or similar, in the slotted area on the right hand-side panel of the radio.

Figure 3-1. MICOM-3F Control Head Removal

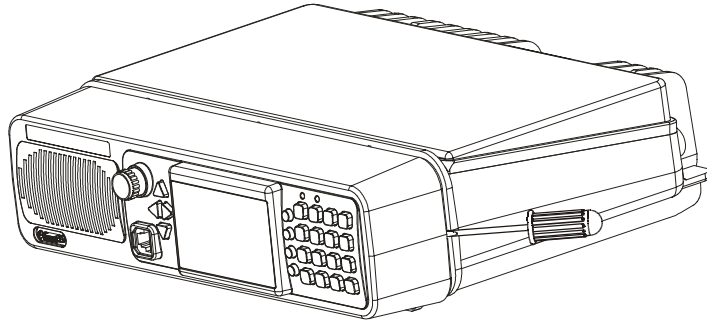

2. Press until the side of the control head releases.
3. Gently pull the control head away from the main board.
4. Remove the flat cable from the socket on the radio side.

Note This procedure is also used to open the MICOM-3T control head.

3-2.1.2 Removing the MICOM-3R Control Head

1. Unscrew the four screws located on the front panel.
2. Gently pull the control head away from the main board.
3. Remove the flat cable from the socket on the radio side.
4. in case you require to remove the handle, unscrew the fixing screws.

Figure 3-2. MICOM-3R Control Head Removal

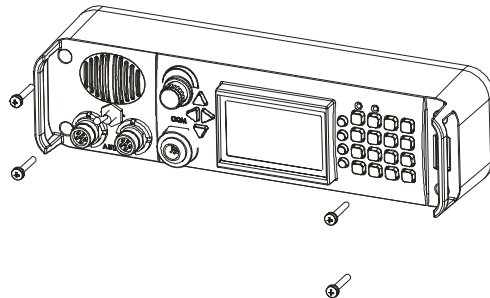

3-2.1.3 Removing the MICOM-3T Front Cover

Release the four screws of the front cover.

Figure 3-3. MICOM-3T Front Cover Removal

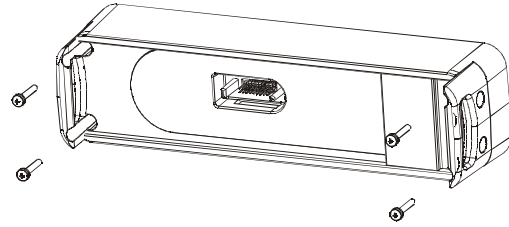

3-2.2 Removing the Cover (8)

See the corresponding MICOM-3 exploded view.

1. Remove the 2 screws (15) securing the cover (8) to the chassis (1).
2. Lift the cover over the chassis.
3. Remove the 2 RF coax cables (16) and the 40-pin flat cable (3).

3-2.3 Removing the RF Shield (13)

See the corresponding MICOM-3 exploded view.

1. Release the 6 screws (14) of the RF shield (12).
2. Remove the RF shield (12) and upper contacts (11) by gently prying up each corner of the shield.

3-2.4 Removing the High Power Board (4)

See the corresponding MICOM-3 exploded view.

1. Remove the PA shield (7).
2. Unplug the antenna connector from the PCB.
3. Remove the screws (5) and (6) securing the High Power board to the radio chassis.
4. Remove the screws securing the power transistors and the final transformers.
5. Remove the 4 screws securing the 4 regulators.
6. Carefully remove the High Power board (4) by rotating it out of the chassis.

3-2.5 Control Head Disassembly

See the corresponding Control Head exploded view.

1. Release screw (15) from the PCB and unplug the speaker connector.
2. To pull out the printed circuit board from the control head housing, insert a small blade screw driver in the side groove near the five protruding tabs. Remove the board from the control head housing.
3. Remove the keypad from the PCB assembly.
4. Disconnect the board from the speaker by removing it from the socket.

5. Take the LCD frame or other parts out of the control head.

3-3. MICOM-3 Assembly

3-3.1 Control Head Assembly

See the corresponding Control Head exploded view.

1. Place the speaker gasket (2) on the front panel (1) with the adhesive side towards the speaker.
2. Make sure the speaker (3) including the gasket is well positioned.
3. Position the speaker spacer (4) on the speaker (3) and secure it with 4 screws (5).
4. Insert the volume knob (6) into the knob opening located on the front panel. Ensure the knob fits and that you are able to rotate it in the clockwise direction.
5. Insert the LCD frame gasket (7) into its place.
6. Position the color sheet on the LCD frame.
7. Position the LCD display (8) onto the LCD frame and snap it into its place.
8. Insert the LCD frame with LCD and Zebra connectors into its place.
9. Place the keyboard onto the board assembly, making sure the keypad (12) is flush with the board.
10. Rotate the knob counter-clockwise to the OFF position.
11. Position the PCB holder (14) on the PCB and snap it in place. Secure it with the screw (15).
12. Position the LCD window (16) and the logo label (17) in the front panel.

3-3.2 High Power Board Assembly

See the corresponding MICOM-3 exploded view.

1. Ensure the regulator insulators are located on the chassis.
2. Inspect and if necessary, reapply thermal grease to the heatsinking pads on the chassis.
3. Replace the PA insulator (2) on the High Power board.
4. Connect the 40-pin flat cable (3) to the High Power board connector and replace the board on the chassis.
5. Insert the 40-pin flat cable through the opening towards the Control Head.
6. Position the High Power board correctly on the chassis (the 3-pin connector faces its recess in the chassis).
7. Install the power transistor screws (6).
8. Install the regulator screws.
9. Install the transformer screw.
10. Install the board screws (5).
11. Connect the antenna connector plug to the PCB.

12. Replace the PA shield (7).

3-3.3 LORD Board Assembly

See the corresponding MICOM-3 exploded view.

1. Make sure the cover (8) including the gasket (9) is well positioned.
2. Positioned the RF shield contacts on the RF shield.
3. Replace the PCB (13) with the 25-pin connector facing its recess in the low RF chassis.
4. Place shield on the PCB and secure it with the 6 screw (14).

3-3.4 MICOM-3 Assembly

See the corresponding MICOM-3 exploded view.

1. Replace the cover (8) on the chassis (1) and secure it with 2 screws (15).
2. Connect the 2 RF coax cables (16), the 24-pin flat cable (17) and the 40-pin flat cable (3) (see also Figure 5-9).
3. Place the front panel gasket (18) on the chassis (1) and insert the 24-pin flat cable through the opening in the gasket.
4. Position the gasket correctly around the chassis.
5. Reinstall the Control Head or front cover as follows:
 - For the MICOM-3F, press the Control Head onto the radio chassis snap until the protruding taps on the chassis snap into the recesses inside the control housing.
 - For the MICOM-3R and MICOM-3T, use the following procedure:
 - Place the front panel gasket (18) on the chassis (1) and insert the 24-pin flat cable and the ground wire through the opening in the gasket.

Note *Make sure that the front panel gasket is lubricated with NYE Fluorocarbon 865.*

- Position the gasket correctly around the chassis.
- Lock the 24-pin connector and the ground wire.
- Press the Control Head or front cover onto the radio chassis and fasten with the four screws removed in para. 3-2.1.2 and 3-2.1.3.

Intentionally Left Blank

Chapter 4

Radio Tuning Procedure

4-1. General

Following service, three calibrations are required:

- Transmitter calibration
- Power calibration
- Oscillator calibration.

An IBM PC (personal computer) and RSS (Radio Service Software) package, G424 (FVN4841), are required to align the radio. Refer to the RSS manual, publication number 6886867J01, for software installation and setup procedures.

4-2. Transmitter Calibration

1. Rotate fully clockwise potentiometers R299 (driver bias) and R298 (output bias), on the High-Power board.
2. Ensure that the High-Power board heatsink temperature is $25 \pm 5^{\circ}\text{C}$ and that no audio input is present.
3. Measure Q34 or Q35 transistors base voltage. Adjust R298 until the measured base voltage is $0.63 \pm 0.01\text{V}$.
4. Measure Q31 or Q32 drivers base voltage. Adjust R299 until the measured base voltage is $0.76 \pm 0.01\text{V}$.

4-3. Power Calibration

Perform the power calibration according to the power calibration procedure in the RSS manual.

4-4. Oscillator Calibration

Perform the oscillator calibration according to the calibration procedure in the RSS manual.

Intentionally Left Blank

Chapter 5

Theory of Operation

5-1. Introduction

See Figure 5-3, MICOM-3 block diagram.

This section provides a functional description of the MICOM-3 radio, in the following order:

- Transmitter
- Receiver
- Synthesizer
- Electronic boards.

5-2. Transmitter

Incoming audio signal is fed directly to the DSP processor U6042 after amplification and filtration. The DSP algorithm is translating the incoming audio signal to a stream of I and Q bits (Inphase and Quadrature). This I/Q representation of the audio signal is transferred to the Digital SSB modulator U6000 where a digital quadrature mixing is performed. The digital signal is then transferred to Sigma-Delta D/A which converts the digital signal to an analog form. The result is the "classic" IF SSB signal with a suppressed carrier at 1.05 MHz and "natural" suppression of the unwanted sideband. Since the quadrature mixing is performed digitally, there are no amplitude and phase inaccuracies which may degrade the unwanted carrier and unwanted sideband suppression. The only limiting factor is the performance of the Hilbert transform, performed by the DSP. Since this performance is controllable, the algorithm is designed to achieve unwanted sideband attenuation of at least 60 dB.

The 1.05 MHz IF signal is converted to 45.1 MHz IF signal at mixer U1108 and then amplified by Q1006. The crystal filter stage cuts out unwanted mixing products and suppresses spurious signals. This unit consists of crystal units FL1 and FL2, centered at 45.1 MHz.

The last conversion stage of the transmission path, implemented by mixer U1000, converts the signal to the final transmission frequency.

The transmission signal is then amplified by the exciter stage Q1004, Q1005 and then transferred to the High Power board, where it first passes the ALC attenuator Q39 and is amplified by the pre-driver amplifier, which consists of Q2-Q6.

The Power stage consists of two transistor pairs acting as two cascaded push-pull stages the driver stage (Q32 and Q33) is connected to the final stage (Q34 and Q35) via transformer T5. The output of the power amplifier is transferred to a 50 Ω impedance by transformer T3.

Maximum output power is 125W PEP (Peak Envelope Power) and average at transmission duty cycle of 1 to 4. Output power can be preprogrammed to one of 4 possible levels: 25W, 50W, 62.5W and

125W. Accurate sensors and the radio software keep the output power within the nominal output power $\pm 7.5\%$.

The transmitter includes thermal protections. If, for any reason, the transmitter internal temperature exceeds the maximum permitted temperature, the output power is automatically reduced to avoid any fault due to excessive heat.

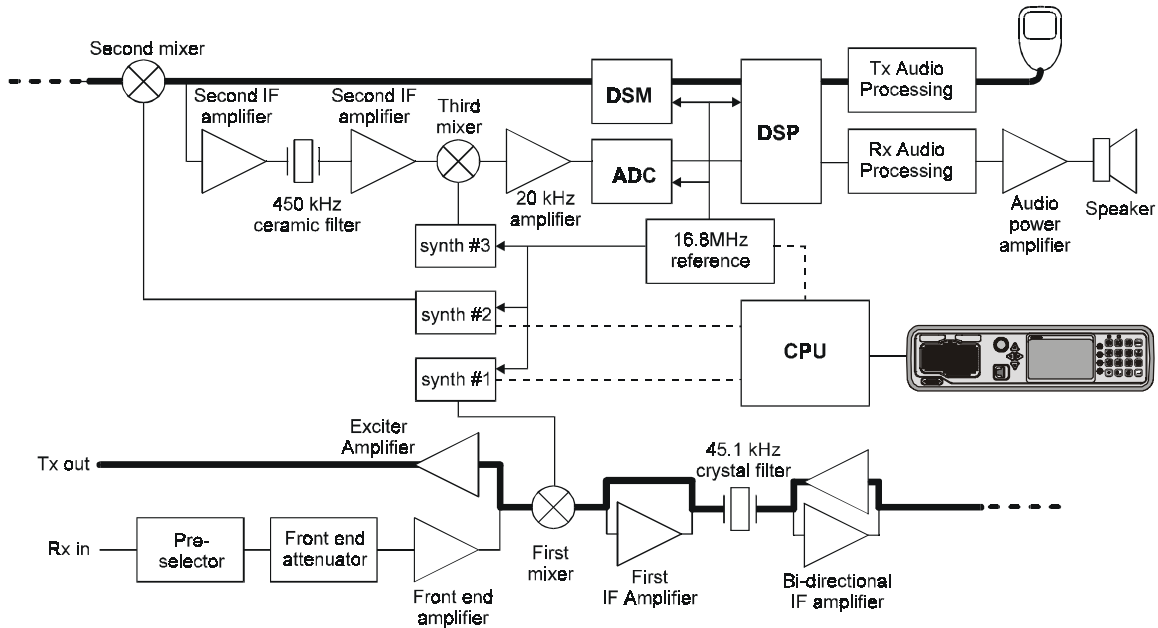

Figure 5-1. Signal Flow through the Transmitter (LORD Board)

Mismatch protection is also included. If VSWR (Voltage Standing Wave Ratio) is worse than 2:1, the output power is proportionally reduced to avoid damaging the transmitter.

Seven different multi-section elliptical low-pass filters are inserted between the transmitter's final output stage and the antenna to reject spurious and harmonic frequencies. The seven filters cover seven frequency ranges and are automatically switched by PIN diode switches into the circuit according to the channel selection. The frequency range of these filters are: 1.6 to 2.43 MHz, 2.43 to 3.7 MHz, 3.7 to 5.6 MHz, 5.6 to 8.5 MHz, 8.5 to 13 MHz, 13 to 19.8 MHz and 19.8 to 30 MHz.

The radio has a closed loop automatic level control (ALC) which keeps the output power within the limits of 125 ± 10 Watts.

The automatic gain control loop begins at the output of the harmonic filter near the antenna output where the output power is sampled (see T6 and its peripheral components in High Power board schematics). A voltage proportional to the output power is fed back to the power amplifier unit and enters a comparison amplifier U6 which compares the sample of the output level with the level determined by the power adjustment word stored in the radio memory and translated to an analog level by D/A U1104 on the LORD board. For every frequency range, the radio stores the appropriate power level word. The output of the comparison amplifier is fed to RF attenuator composed of CR54, CR56. Thus attenuator regulates the input power to the RF amplifier, keeping the output level constant.

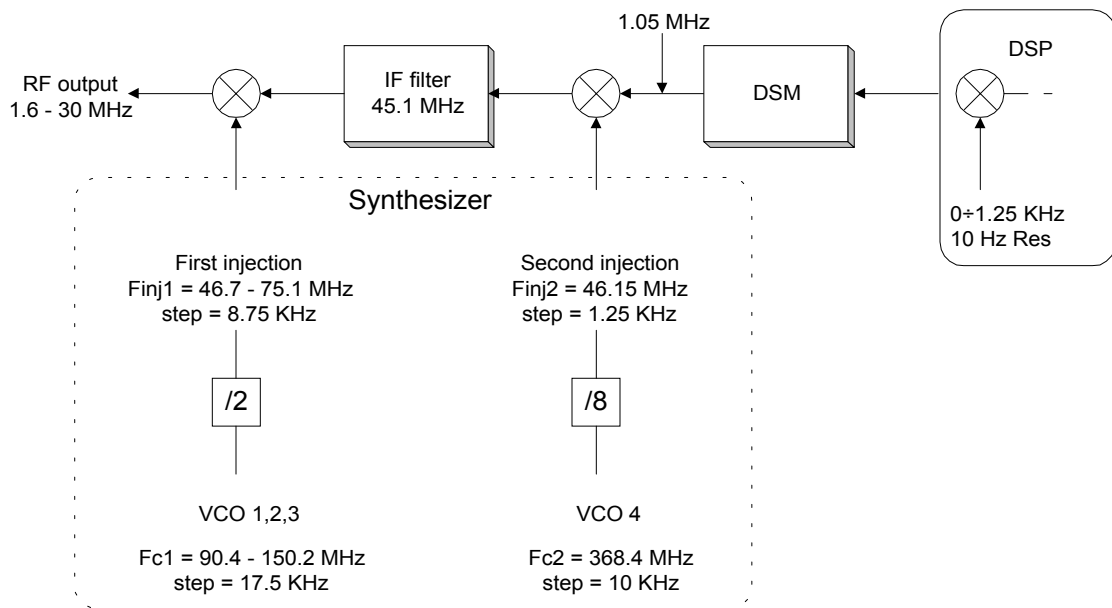

Figure 5-2. Transmit Path Frequency Conversion Scheme

Intentionally Left Blank

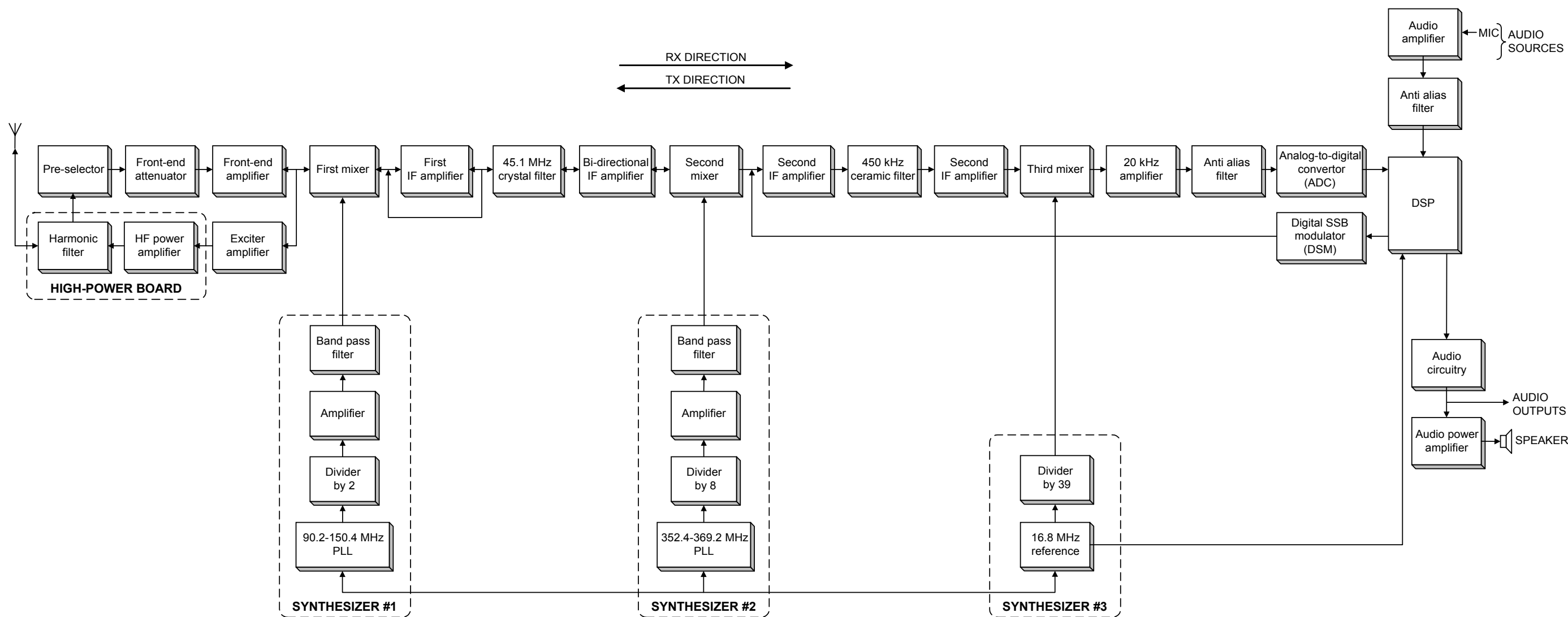

Figure 5-3. Micom-3 Block Diagram

5-3. Receiver

The receiver functions as an SSB demodulator for the HF band. It is based on a triple conversion scheme, which converts a specific 2.7 kHz band of the received spectrum to the input of an ADC (Analog to Digital Converter), centered at 20 kHz.

The conversion chain is based on analog circuitry that was designed to withstand out-of-band interference. The frequency resolution of both injections is limited to 1.25 kHz, which is insufficient to provide the specified 10 Hz resolution. Therefore, the analog section of the conversion chain provide a coarse tuning only.

After being digitized by the ADC, the received signal is being frequency shifted to the exact frequency by a digital algorithm in the DSP. This fine tuning process complements the coarse tuning performed by the analog section of the receiver. After being fine tuned, the signal is SSB demodulated and filtered according to the radio specifications.

The distribution of the overall frequency resolution between the DSP stage (fine tuning) and the analog stages (coarse tuning) is common to the receive and the transmit chains.

The RGC (Receiver automatic Gain Control) is an important segment of the receiver. It is based on analog attenuation stages, distributed along the analog part of the receiver chain, and a digital algorithm within the DSP. The analog attenuation stages serves as a step-attenuator. Each stage provides 0 dB attenuation or, when activated, a predefined attenuation. Therefore, the analog section of the receiver can provide only a coarse gain control.

The DSP controls the activation of these step-attenuator stages, while adding a smoothly varying gain control by scaling the signal after fine tuning and filtering. The overall performance of the RGC provides a 100 dB range, starting from -90 dBm.

The DSP processed signal is an audio signal which is amplified to levels up to 5W.

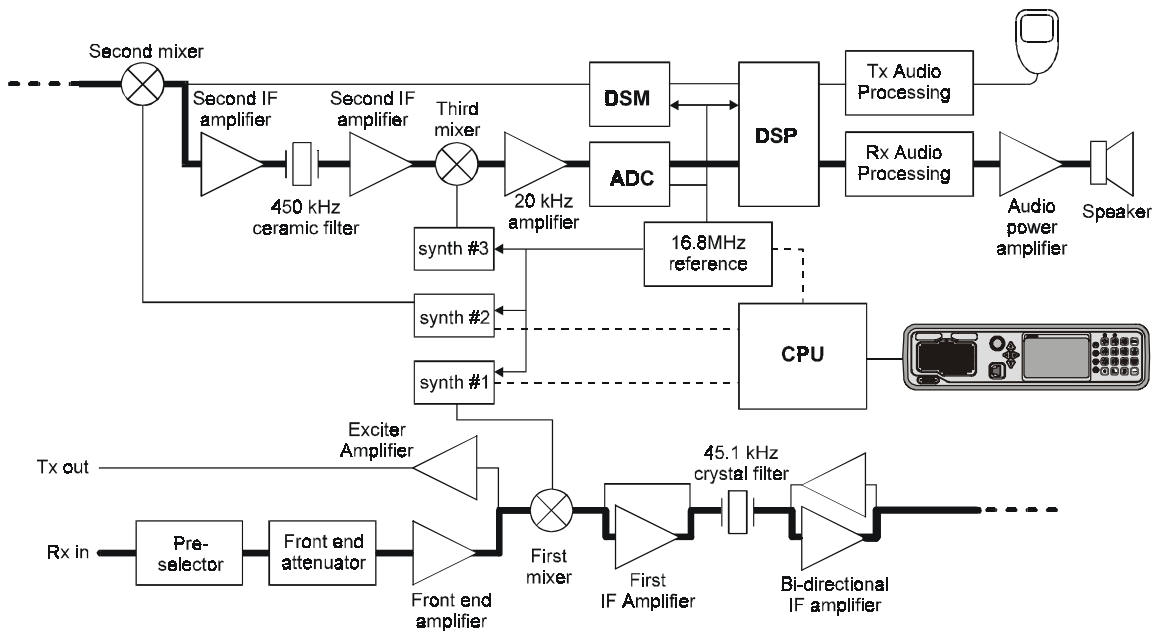

Figure 5-4. Signal Flow through the Receiver

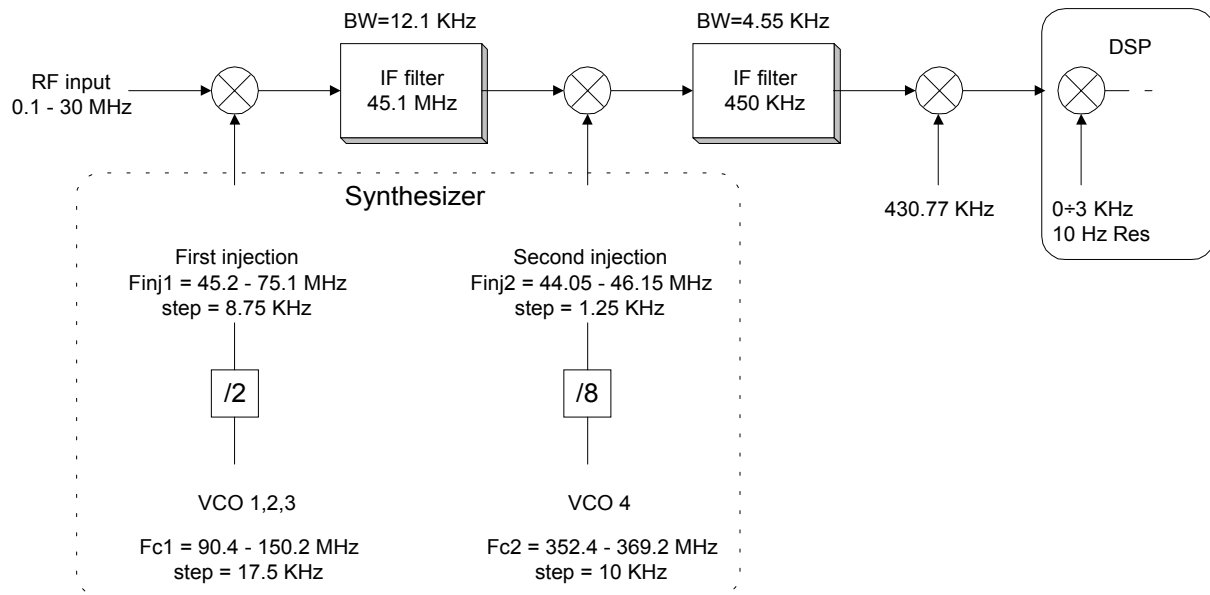

Figure 5-5. Receive Path Frequency Conversion Scheme

5-4. Synthesizer

The synthesizer is designed according to the MICOM-3 frequency plan, described in Figure 5-6.

The conversion principles are as follows:

- Receive path: the analog section performs triple frequency conversion; a fourth frequency conversion is done digitally.
Receive path bandwidth, 10 kHz, is determined by a ceramic filter at a 450 kHz frequency.
- Transmit path: the analog section performs double frequency conversion; a third frequency conversion is done digitally.
- The conversion frequency resolution of the analog part is 1.25 kHz.

The synthesizer provides two signals to the transmission and reception paths. The first injection signal covering 45.2 to 75.1 MHz is produced by a PLL (phase locked loop). To enable wide range coverage while maintaining low noise performance, the 45.2 to 75.1 MHz loop uses three VCOs (Voltage Controlled Oscillator) in three subranges. The second injection signal is also generated by a PLL IC covering the 44 to 46 MHz range with one VCO.

In both loops, the VCO frequencies are higher than the output frequencies. The first injection uses a division by two (U2002) and the second injection uses a division by eight (U2003). The frequency division decreases spurious level without degrading the lock-in time of the PLL. Frequency division improves frequency resolution too. Thus, the first injection provides a 8.75 kHz resolution and the second injection provides a 1.25 kHz resolution.

Both loops use a single reference oscillator at 16.8 MHz. As a result, the overall radio frequency stability and accuracy are determined by the accuracy and stability of this single reference oscillator.

The reference oscillator is a 1 ppm DTCXO (0.1 ppm OCXO for MICOM-3R). An optional 0.1 ppm OCXO can be ordered, for enhanced frequency accuracy. The OCXO is a hybrid add-on that is thermally isolated. It contains a 16.8 MHz crystal oscillator. The temperature of the oscillator is

controlled to 85°C, using a heat dissipating power transistor and a thermistor that monitors the temperature and provides feedback to a temperature controller circuitry on board.

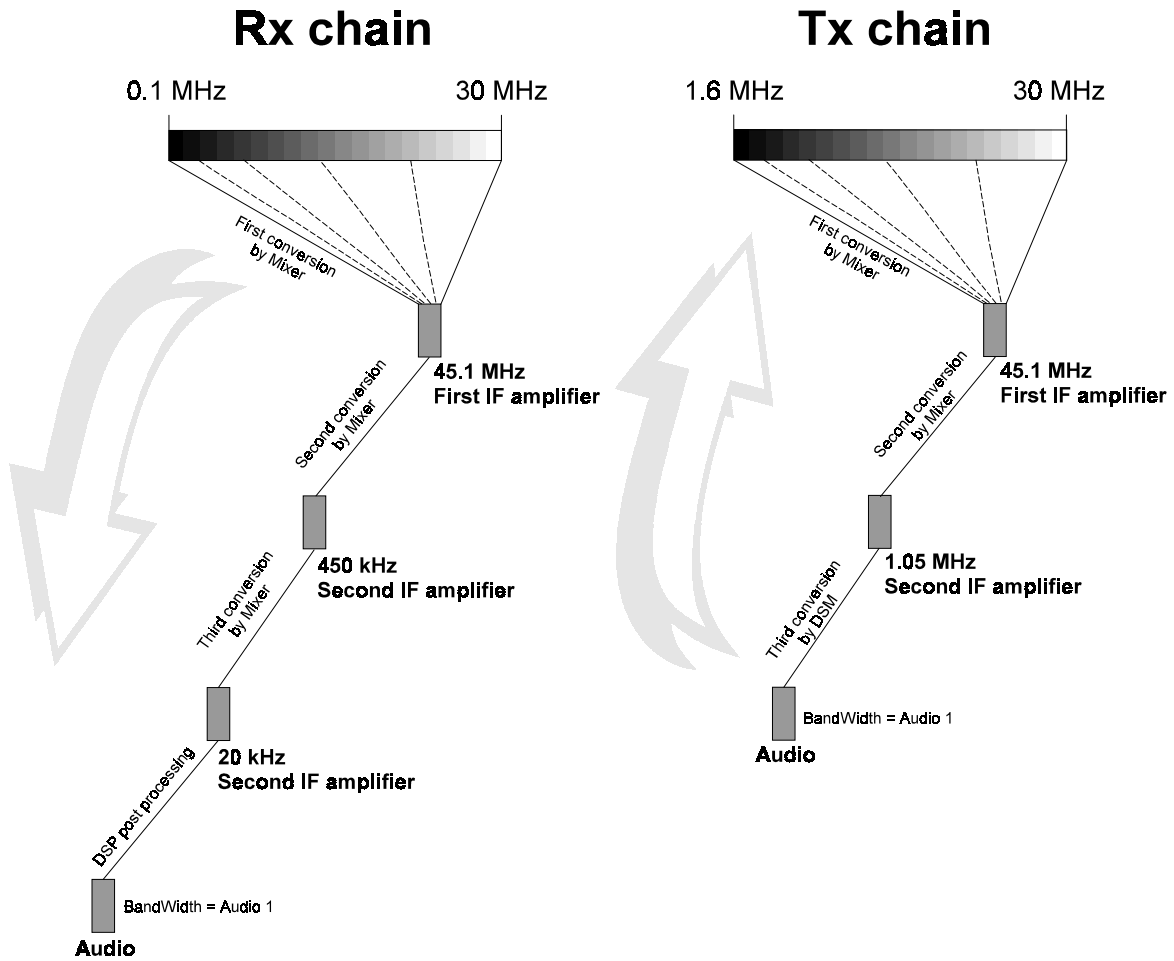

Figure 5-6. Bandwidths and Frequency Plan

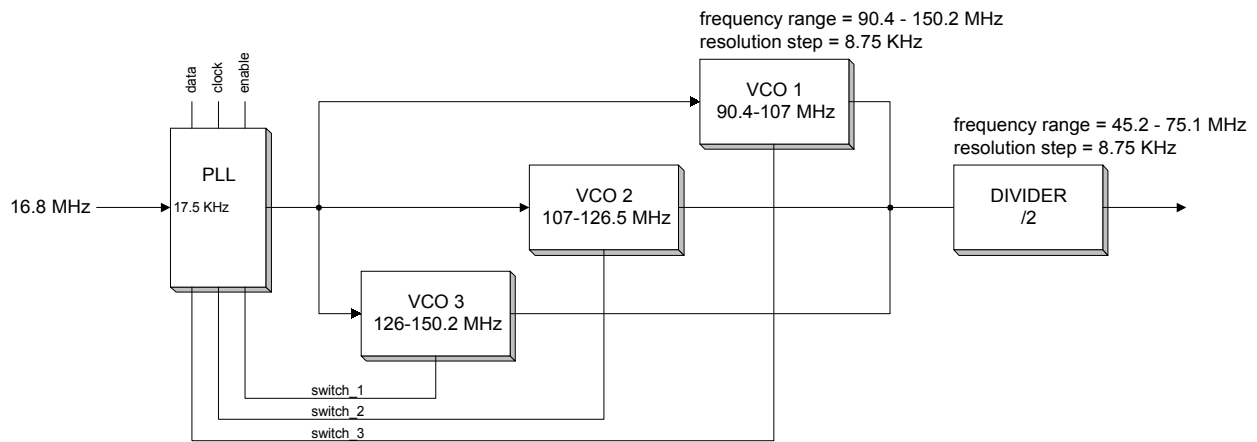

Figure 5-7. First Injection Block Diagram

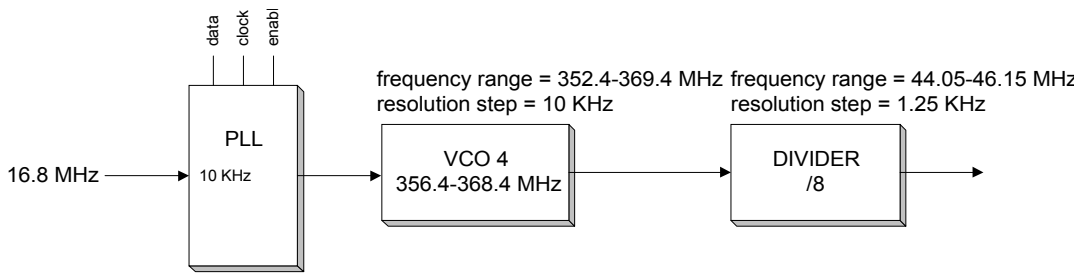

Figure 5-8. Second Injection Block Diagram

5-5. Electronic Boards

The circuitry of the basic MICOM-3 radio is located on three main boards, as follows:

- Low RF and Digital (LORD) board
- High-Power board
- Control Head board (two versions with similar characteristics are used, one for MICOM-3F and MICOM-3T, and the other for MICOM-3R).

Note MICOM-3T also uses an Interconnection board for connection to the Control Head board.

Figure 5-9 identifies the main boards and Table 5-1 indicates the location of the main radio circuits.

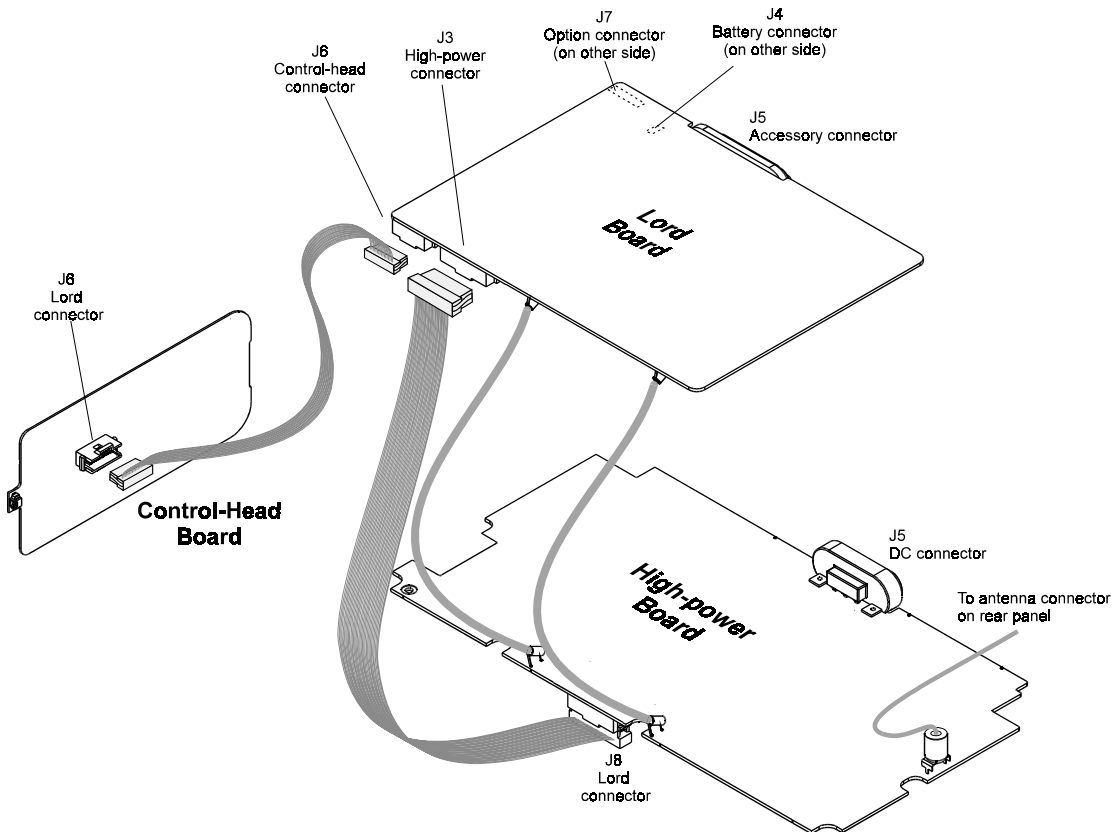

Figure 5-9. Identification of Main MICOM-3 Boards

Table 5-1. Location of Main MICOM-3 Circuits

Circuit	High-Power Board	LORD Board	Control Board
Tx/Rx Power Supply	x		
Receive Path	x	x	
Excitation		x	
Amplification and HF Processing	x		
DSP		x	
CPU		x	
Audio Processing		x	
Loudspeaker and Volume Control			x
Keyboard			x
Activation			x
Interfacing		x	
Frequency Reference		x	
Temperature Control	x	x	
Transmit Power Control	x	x	
Digital Voltage Supply	x		
Main Voltage Switching	x		

5-5.1 LORD Board

The LORD board functional block diagram is shown in Figure 5-3. Typical signal levels and frequencies are given in Figure 5-10.

These signals can be measured with a spectrum analyzer at the test points detailed in this figure. The location of the mentioned test points is illustrated in Figure 5-11.

Gain (dB)	-3	-2.5	0	13	10	-6	12	-4	15	-
P (dBm)	-95	-98	-100	-100	-86	-98	-104	-88±4	-97	-82
F (MHz)	Fin	Fin	Fin	Fin	Fin	Fin	45.1	45.1	45.1	45.1
Designation	*1	*2	PS_out	AMP_1	AMP_2	Second Mixer	AMP_4	AMP_3	xtal_out	IF2_3

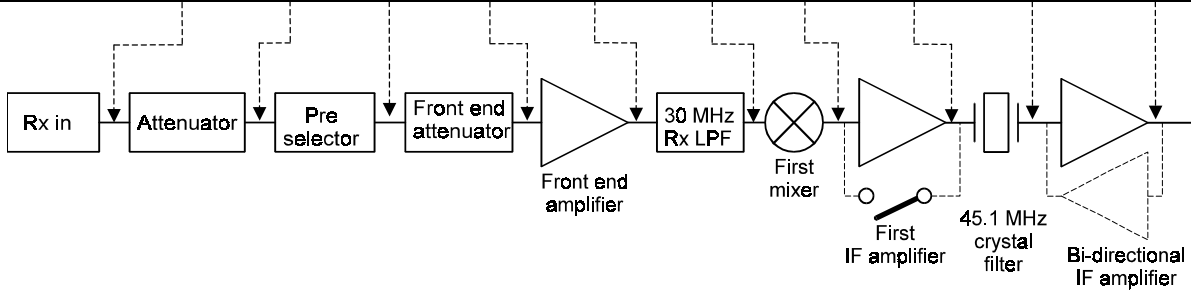

Gain (dB)	-6	22	-1.5	8	-1.5	13	0	28	0	-
P (dBm)	-82	-88	-66	-67.5	-59.5	-61	-48	-48	-20	-20
F (MHz)	45.1	0.45	0.45	0.45	0.45	0.45	0.45	0.02	0.02	0.02
Designation	IF2_3	IF3_1	IF3_2	IF3_3	IF3_4	IF3_5	IF3_6	AF_2	AF_3	ADC_in

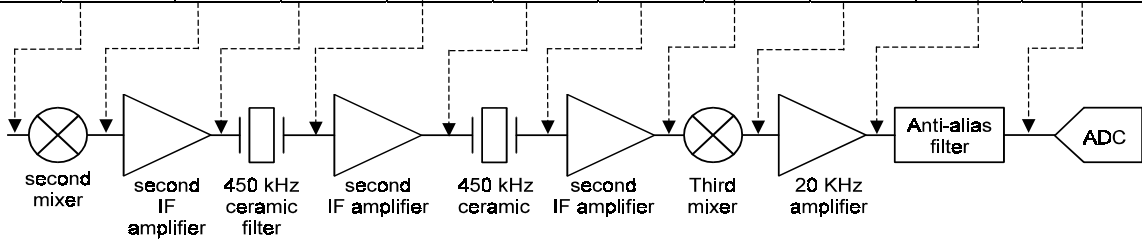

Gain (dB)	-6	15	-4	0	-6	-6	25	-6	-
P (dBm)	-25	-31	-15±4	-21	-27	-33	-6	-6	-12
F (MHz)	1.05	45.1	45.1	45.1	45.1	Fout	Fout	Fout	Fout
Designation	DSM_n	IF2_3	xtal_out	AMP_3	AMP_4	Second Mixer	Ex_amp_lpf	*3	ex_amp_out

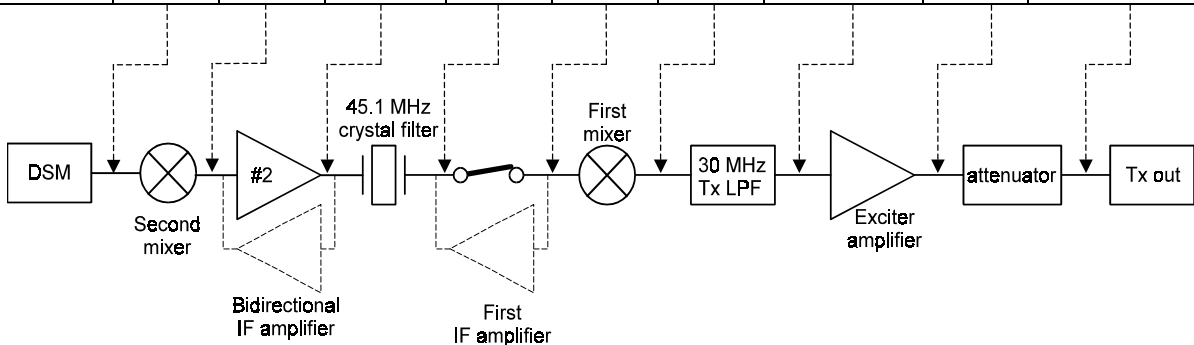

Figure 5-10. Receive and Transmit Signals, Frequencies and Gains

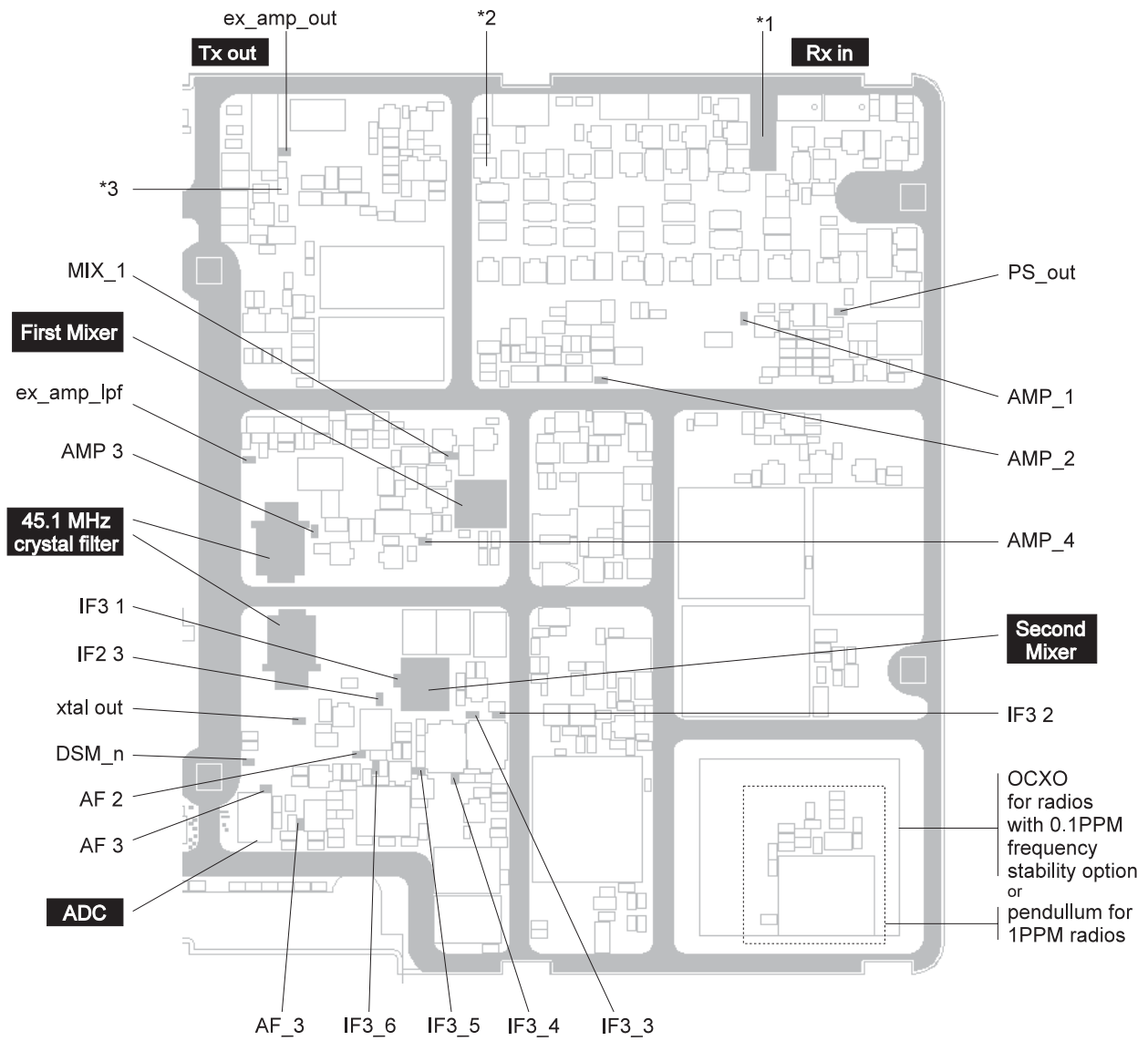

Figure 5-11. Test Points Map

5-5.2 High-Power Board

See Figure 5-12. The High-Power board comprises the Power Amplifier and the Harmonic Filter circuits.

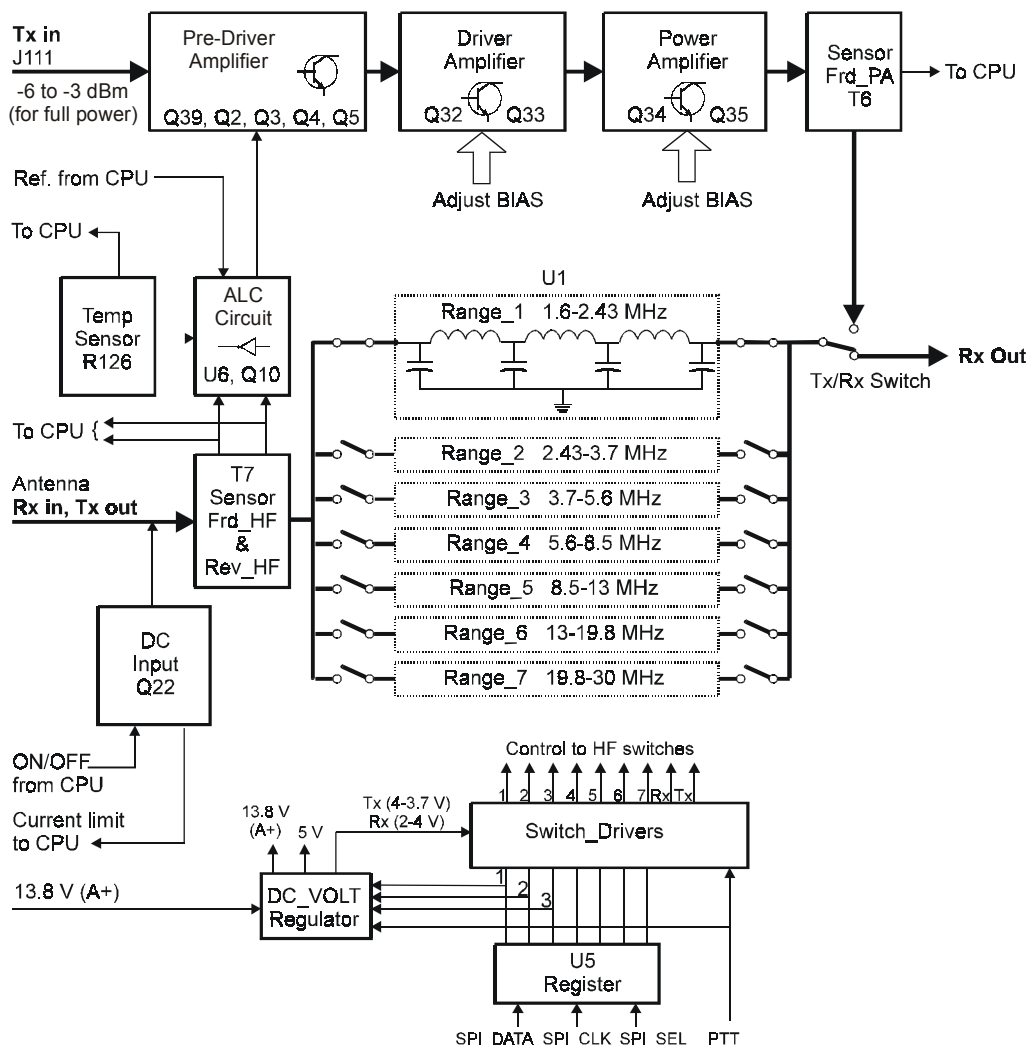

Figure 5-12. High Power Board Functional Block Diagram

5-5.2.1 Power Amplifier (PA)

The PA contains three RF (1.6 to 30 MHz) wide band amplification stages:

- Pre-driver (Q2, Q6)
- Push-pull driver (Q32, Q33)
- Final push-pull power stage (Q35, Q34).

The PA also includes a control circuit which controls the output power level according to the control signal provided by the ALC D/A (controlled by the microprocessor on the LORD board) and the temperature at the final push-pull transistor case. This circuit is implemented by three operational amplifiers (U6) that receive inputs from the ALC D/A and the VSWR detector (the harmonic filter circuit). It controls an active attenuator (CR54 and CR56), which regulates the RF input to the amplification stages.

A two-transistor circuit controls the bias of the driver and final amplifier transistors; as heatsink temperature increases, the circuit reduces the bias correspondingly.

5-5.2.2 Harmonic Filter

The harmonic filter is used to attenuate the unwanted spurious and harmonics of the transmitted and received signals. During transmission, the Tx/Rx switch is in transmit state, transferring the RF output from the PA to the antenna via the harmonic filter. In the receive mode, the Tx/Rx switch is in the receive state, transferring the received signal from the antenna to the LORD board via the harmonic filter.

The harmonic filter contains:

- Seven selectable low pass filters.
- Seven electronic switches. Only one switch is on at any time, while the others remain off.
- Tx/Rx electronic switch (includes CR33, CR34, CR35 and CR36).
- Forward/reflected power detector (includes T7, CR4 and CR5).

The filter ranges and switches are listed in Table 5-2.

Table 5-2. Harmonic Filter Bands/Ranges and Controlling Switches

Filter	Range (MHz)	Switch PIN Diodes
1	1.6 to 2.43	CR40, CR47
2	2.43 to 3.7	CR37, CR44
3	3.7 to 5.6	CR39, CR46
4	5.6 to 8.5	CR42, CR49
5	8.5 to 13	CR41, CR59, CR48, CR59
6	13 to 19.8	CR38, CR45
7	19.8 to 30	CR37, CR44

The harmonic filter contains seven selectable low pass filters, each covering a section of the 1.6 to 30 MHz range. Seven control lines are used to select an appropriate filter according to the operating frequency. When a control line is pulled down, the corresponding PIN diode switch is turned on and inserts the corresponding filter in the signal path.

A forward/reflected power detector is inserted between the filters and the antenna. During transmission it generates two DC signals: one proportional to the forward RF power delivered to the antenna, and the other proportional to the RF power reflected from the antenna. The signals are sent to both the exciter and the Control board for controlling the level of the power output as a function of the following parameters:

- VSWR value. If the VSWR increases above 2:1, the output power is gradually decreased, to protect the radio from high reflected power.
- Harmonic filter insertion losses. If the harmonic filter insertion loss is too high, the output power level is decreased.

Table 5-3. Accessories Connector Pin Functions

Pin	Designation	Function	Direction	Notes
1	SPKR-	Floating output to external speaker	Output	1A
2	STOP SCAN	Digital output indication for stop scan function	Output	
3	SPKR+	Floating output to external speaker	Output	1A
4	EXT RX AUDIO+	Floating receive audio output	Output	0 dBm, 600 Ω
5	EXT RX AUDIO-	Floating receive audio output	Output	0 dBm, 600 Ω
6	EXT TX AUDIO+	Floating transmit audio input	Input	-9 to 0 dBm, 600 Ω
7	EXT TX AUDIO-	Floating transmit audio input	Input	
8	PTT IN VOICE	PTT for voice transmission	Input	
9	PTT IN DATA	PTT for data transmission	Input	
10	PTT IN CW	PTT for Morse (CW) transmission	Input	
11	SW A+	Primary DC voltage output	Output	Max 1A
12	DSI/KW C C	BDM – Data serial in/kW amplifier channel change	Output	Multiplexed signals
13	KW ON OFF	kW amplifier power on/off	Output	
14	REV CLOSE LOOP	Close the loop of ALC radio	Input	
15	RXA	Receive input (point-to-point protocol to host/HLC)	Input	
16	TXA	Transmit output (point-to-point protocol to host/HLC)	Output	
17	EX RESET	External RESET (for BDM)	Input	
18	GND	Ground	Output	
19	KW PTT	kW PTT	Output	
20	EXT ALARM	External alarm output	Output	
21	VPP	Flash programming voltage, input to BDM	Input	Not connected to J1
22	DSC/KW ALC	BDM – Data serial clock/kW amplifier ALC	Input/ Output	Multiplexed signals
23	SQ GATE	Squelch open or closed	Output	
24	DSO/FAN ON OFF	BDM – Data serial out/Fan control	Output	Multiplexed signals
25	FREZE/KW TU	BDM – Freeze/kW amplifier tune	Output	Multiplexed signals
26	GND	Ground	Output	
27	FWD CLOSE LOOP	ALC radio loop closure	Input	
28	RXC	Receive input (point-to-point protocol to host/HLC)	Input	
29	TXB	RS-232 protocol to VP-116, PPS, 500W, ASTIC	Output	

Table 5-3. Accessories Connector Pin Functions (Cont.)

Pin	Designation	Function	Direction	Notes
30	AMP REV	Maintain constant power at 500W transceiver output	Input	
31	RXD	Receive input (point-to-point protocol to host/HLC)	Input	
32	TX AUDIO OUT	Input to baseband TX path	Input	
33	RXB	RS-232 protocol to VP-116, PPS, 500W, ASTIC	Input	
34	RX AUDIO OUT	Input to baseband RX path	Input	
35	RX AUDIO IN	Output from baseband RX path	Output	
36	AMP FWD	Maintain constant power at 500W transceiver output	Output	
37	VP PTT	PTT output	Output	Active low
38	TXD	Transmit output (point-to-point protocol to host/HLC)	Output	
39	TXC	Transmit output (point-to-point protocol to host/HLC)	Output	
40	TX AUDIO IN	Output from baseband TX path	Output	
41	EXT RX AUDIO(2)+	Audio out from ISB hybrid	Output	
42	EXT TX AUDIO(2)-	Audio out from ISB hybrid	Output	
43	EXT RX DATA-	Baseband output	Output	0 dBm, 600 Ω
44	EXT RX DATA+	Baseband output	Output	0 dBm, 600 Ω

Intentionally Left Blank

Chapter 6

Troubleshooting

6-1. Overview

In case of malfunctioning, perform the following steps (refer to the Maintenance section in the MICOM-3F/3T/3R HF-SSB Transceivers Owner's Guide, publication number: 6886867J01):

1. Use BITE function
2. Refer to the User Troubleshooting Chart
3. Follow the troubleshooting procedures in this section which provide instructions for isolating faulty boards.

Troubleshooting a board at component level should be performed according to the relevant schematic diagrams.

6-2. Troubleshooting Charts

This section contains two troubleshooting charts:

- Receiver
- Transmitter.

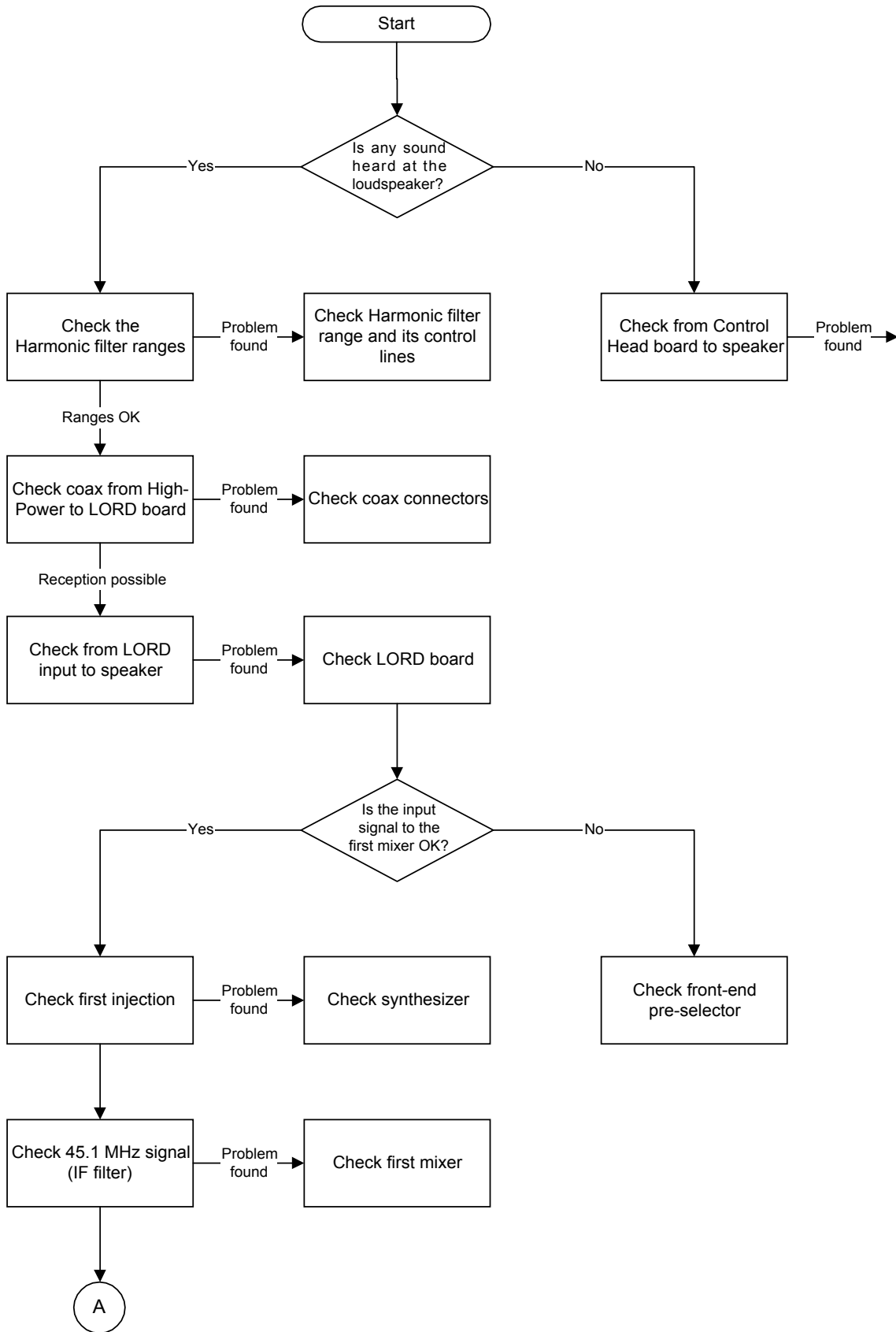

Figure 6-1.A. Receiver Troubleshooting Flowchart (Sheet 1 of 2)

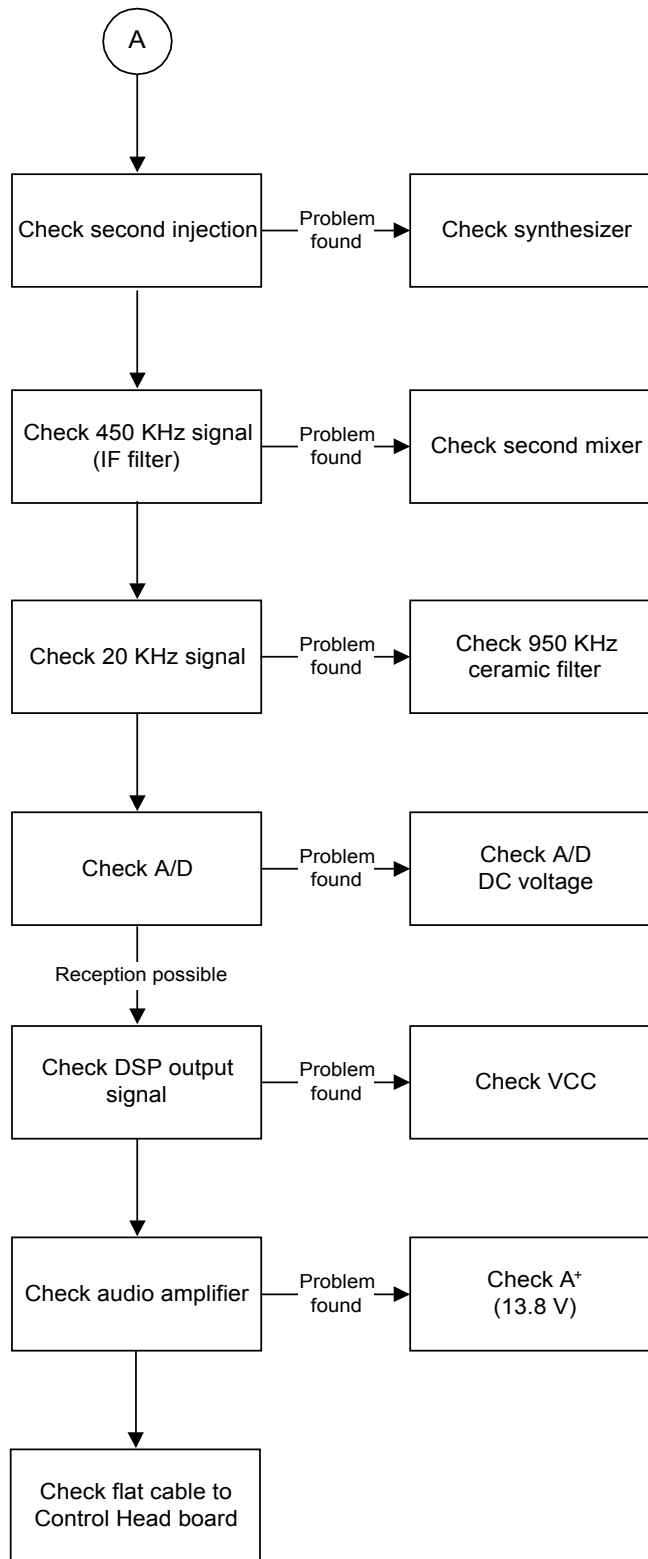

Figure 6-1.B. Receiver Troubleshooting Flowchart (Sheet 2 of 2)

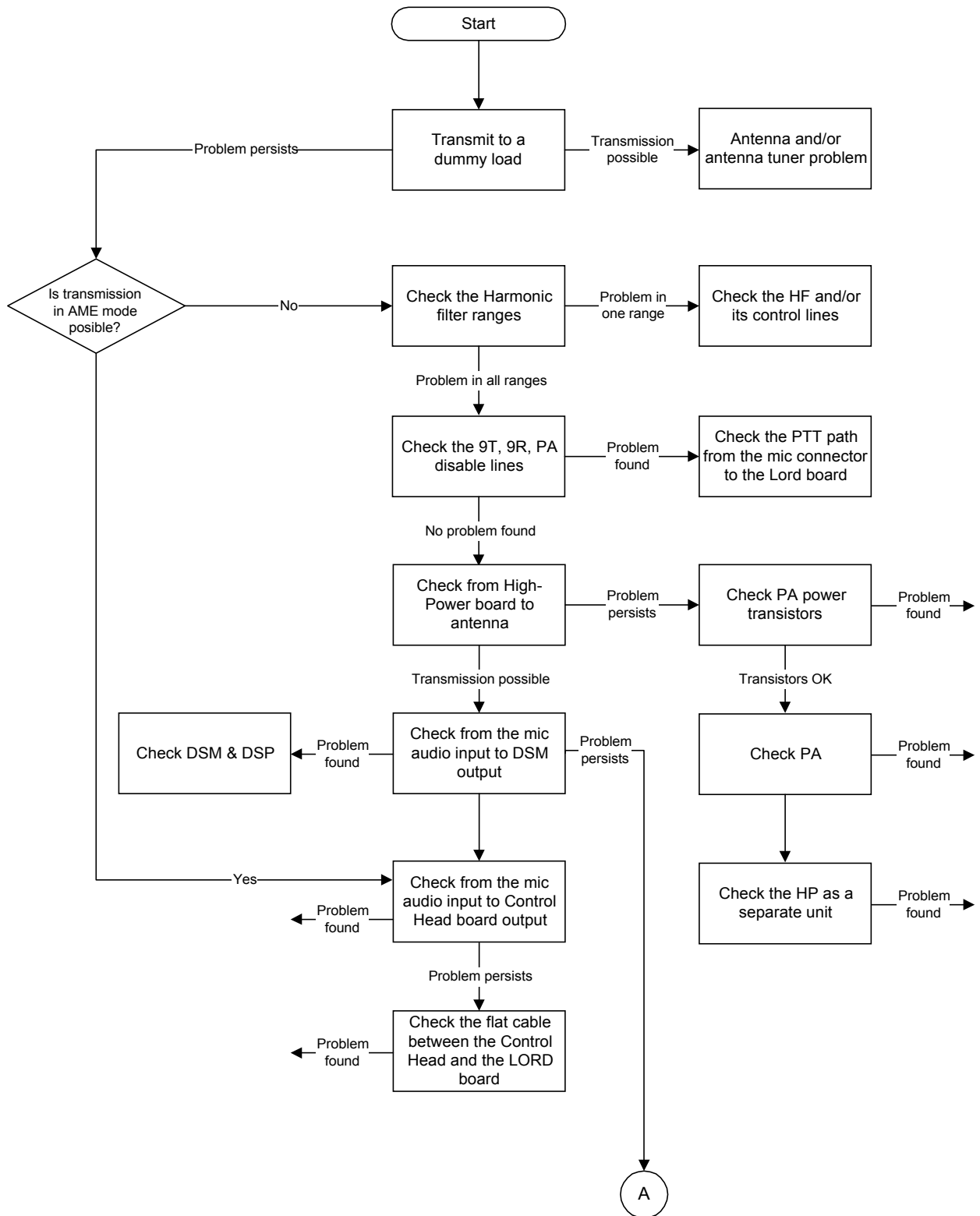

Figure 6-2.A. Transmitter Troubleshooting Flowchart (Sheet 1 of 2)

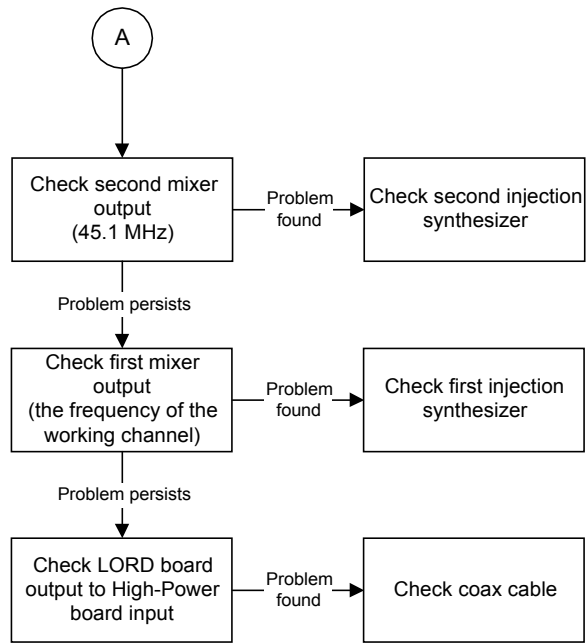

Figure 6-2.B. Transmitter Troubleshooting Flowchart (Sheet 2 of 2)

Intentionally Left Blank

Chapter 7

Schematic Diagrams, Layouts and Parts Lists

Note *Spare parts with Part No. starting with 20 or 40 are plant items.*

LORD BOARD
Model FTN6067A
Printed Circuit Board Details

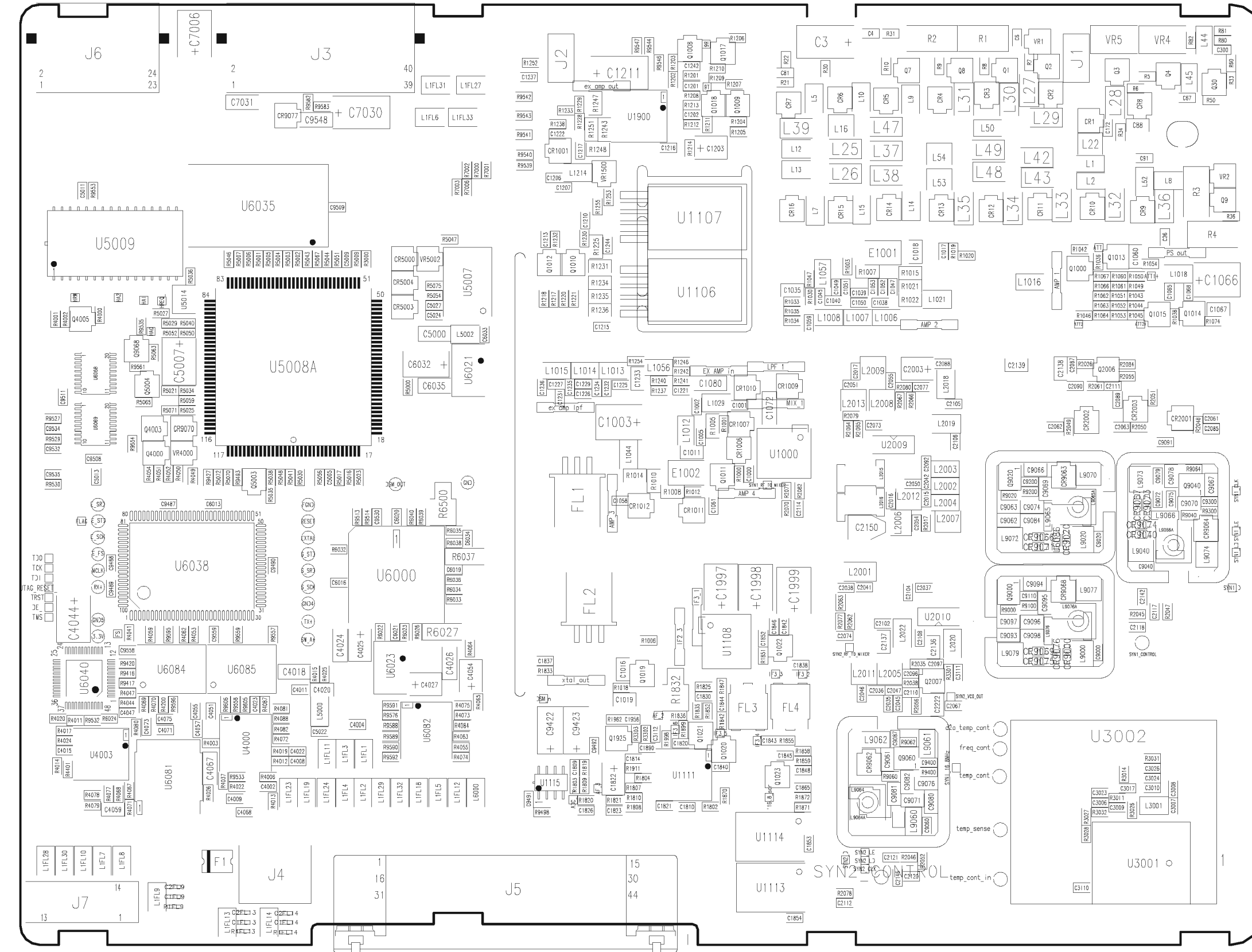

TOP VIEW



BOTTOM VIEW

LORD BOARD
Model FTN6067A
Schematic Diagram - Top Hierarchy

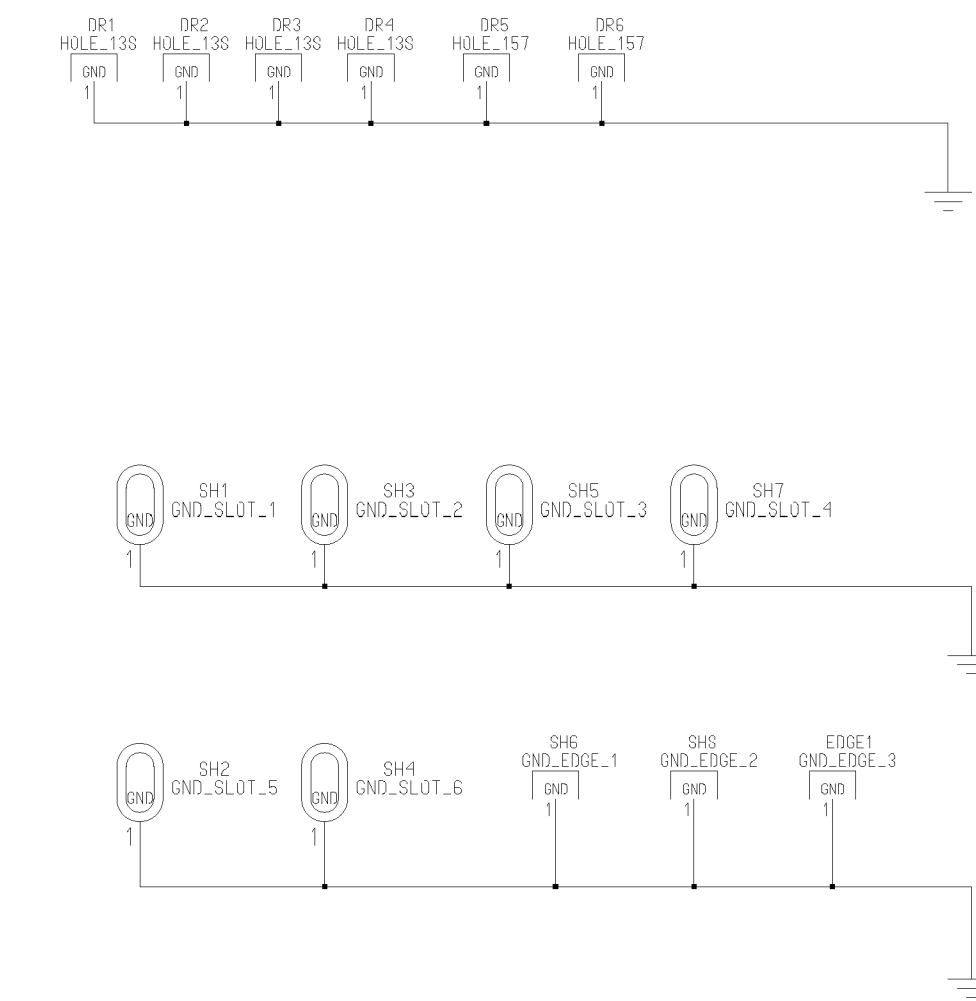
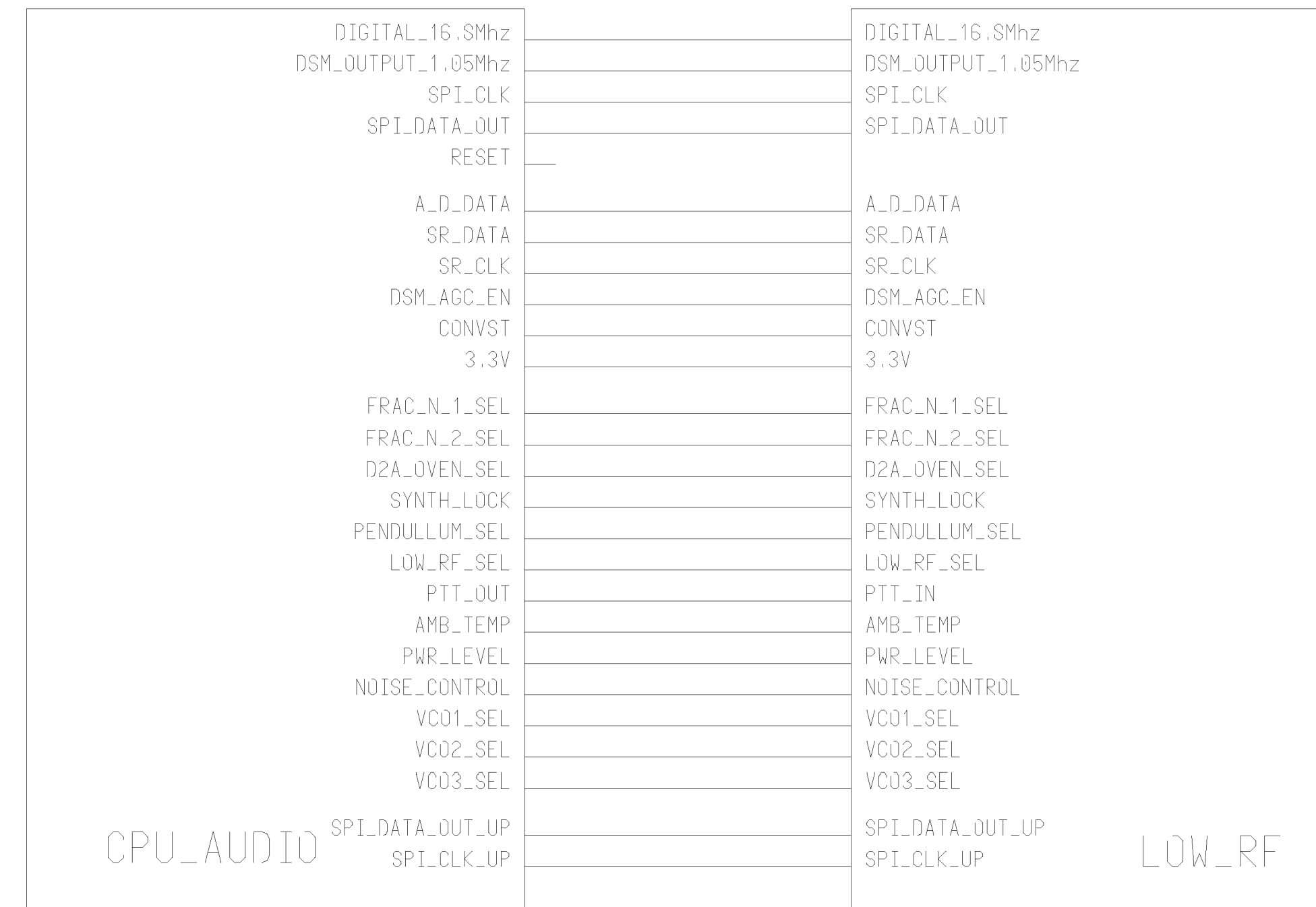

LORD BOARD
Model FTN6067A
Schematic Diagram - RF Section

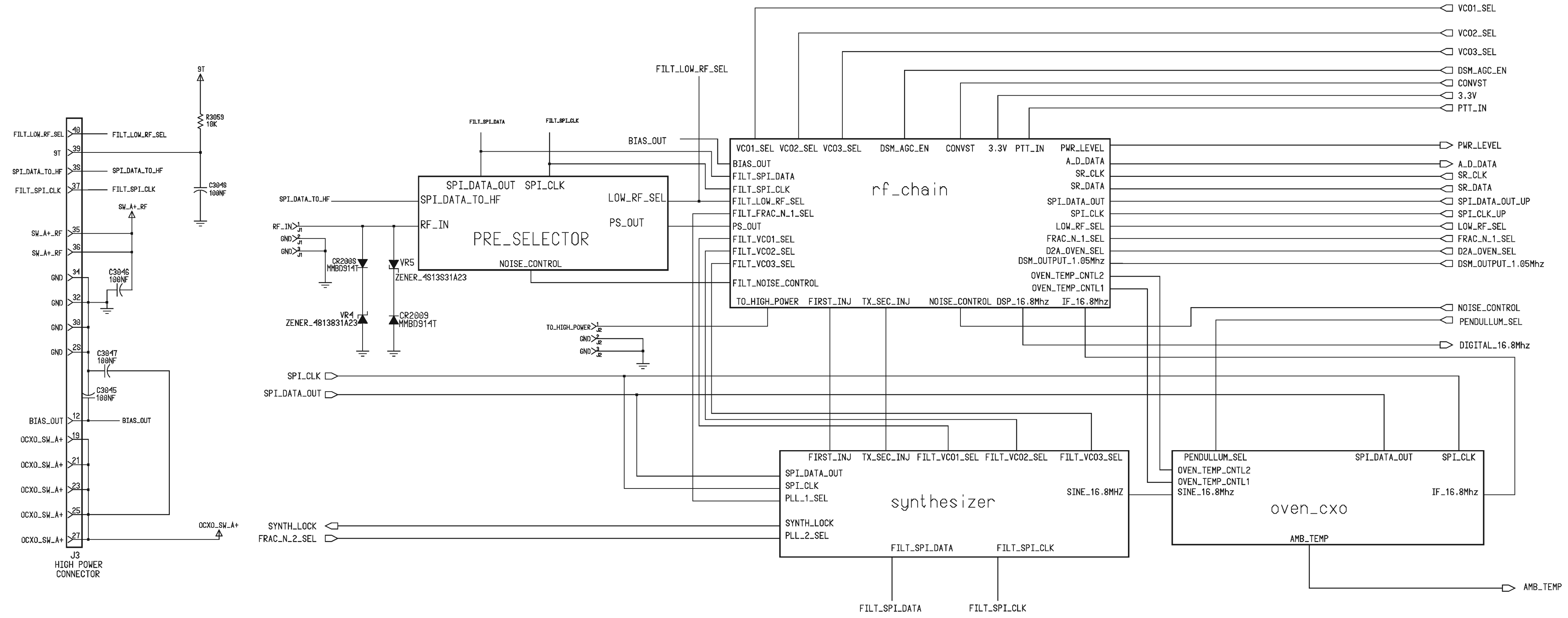

LORD BOARD

Model FTN6067A

Schematic Diagram - RF Section

Pre-Selector Section

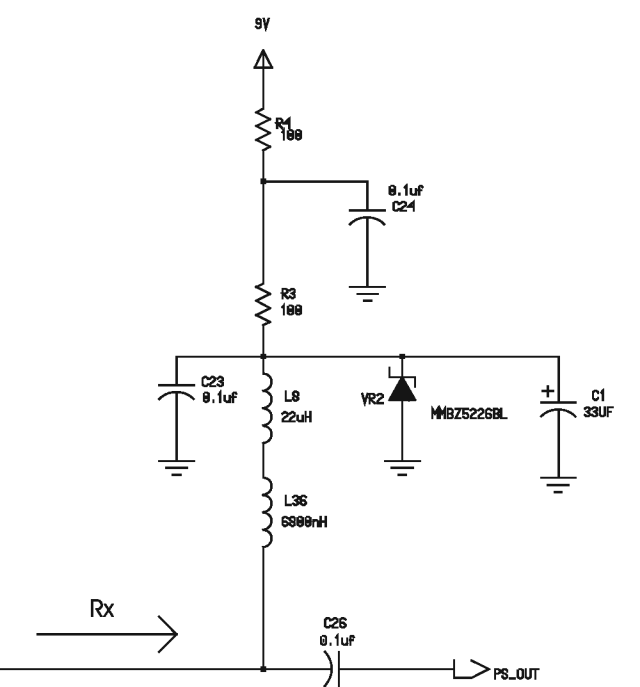
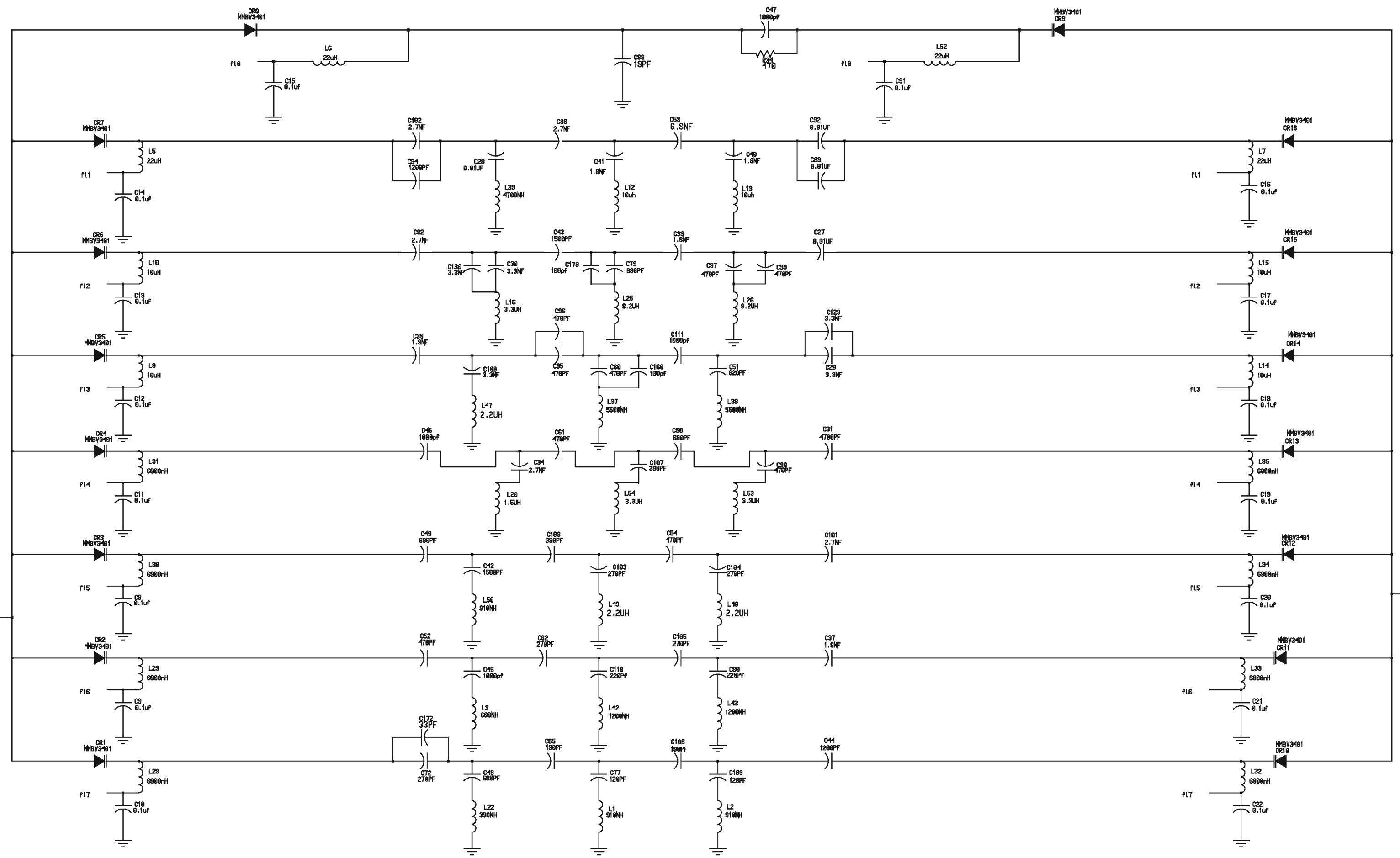
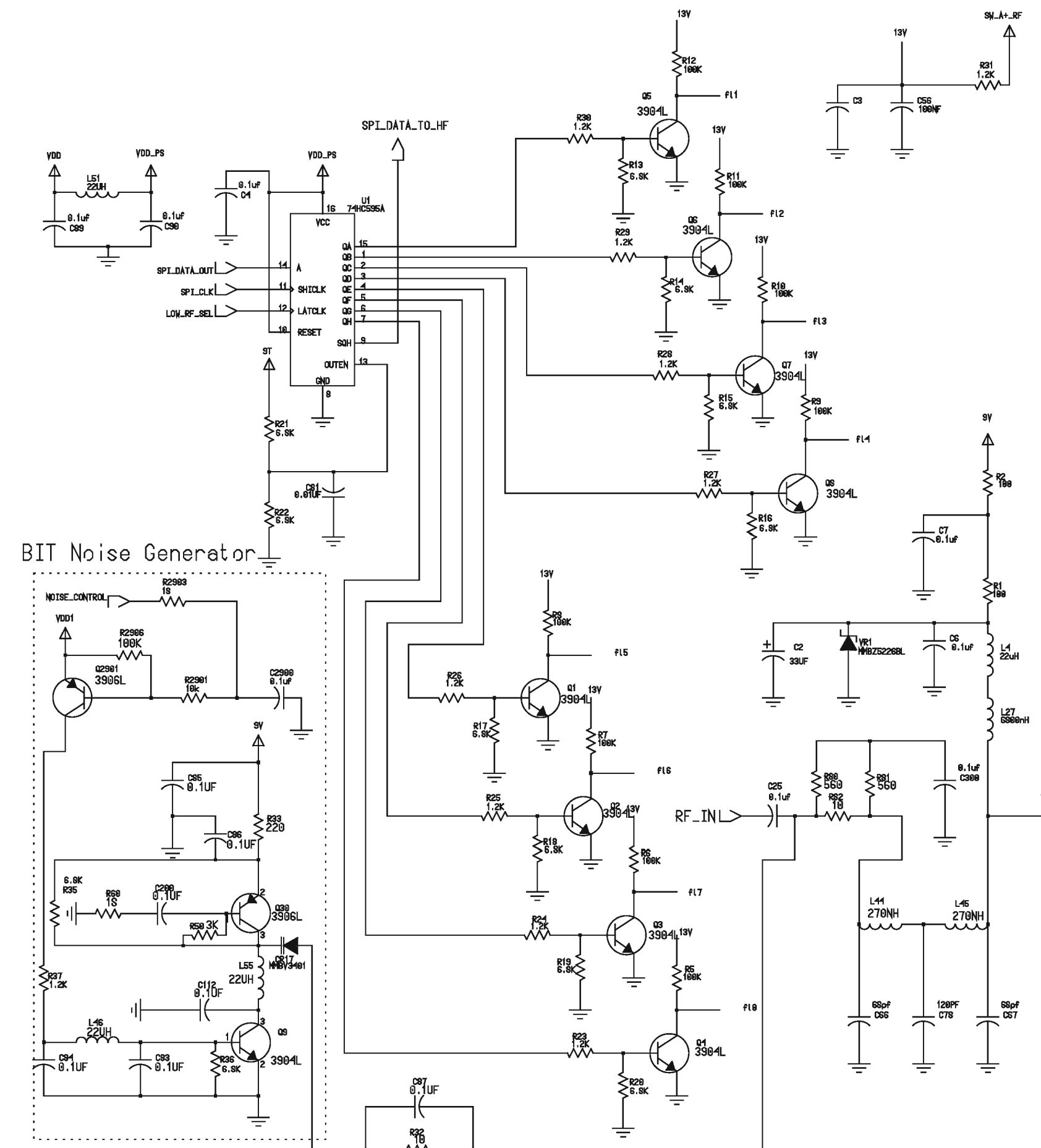

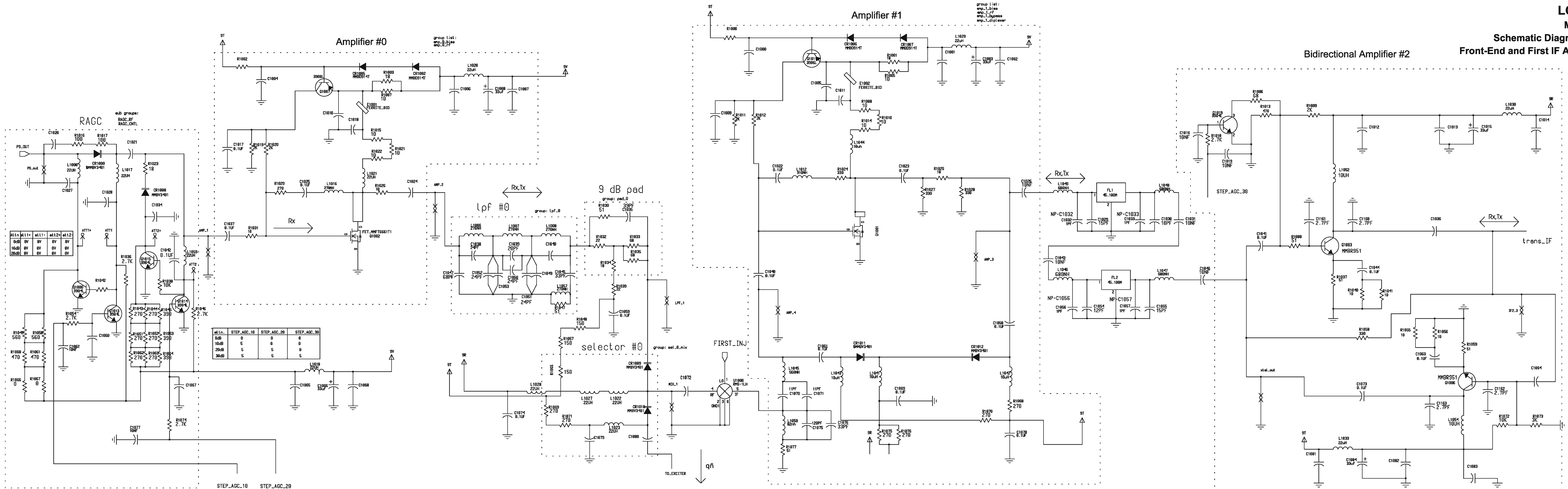

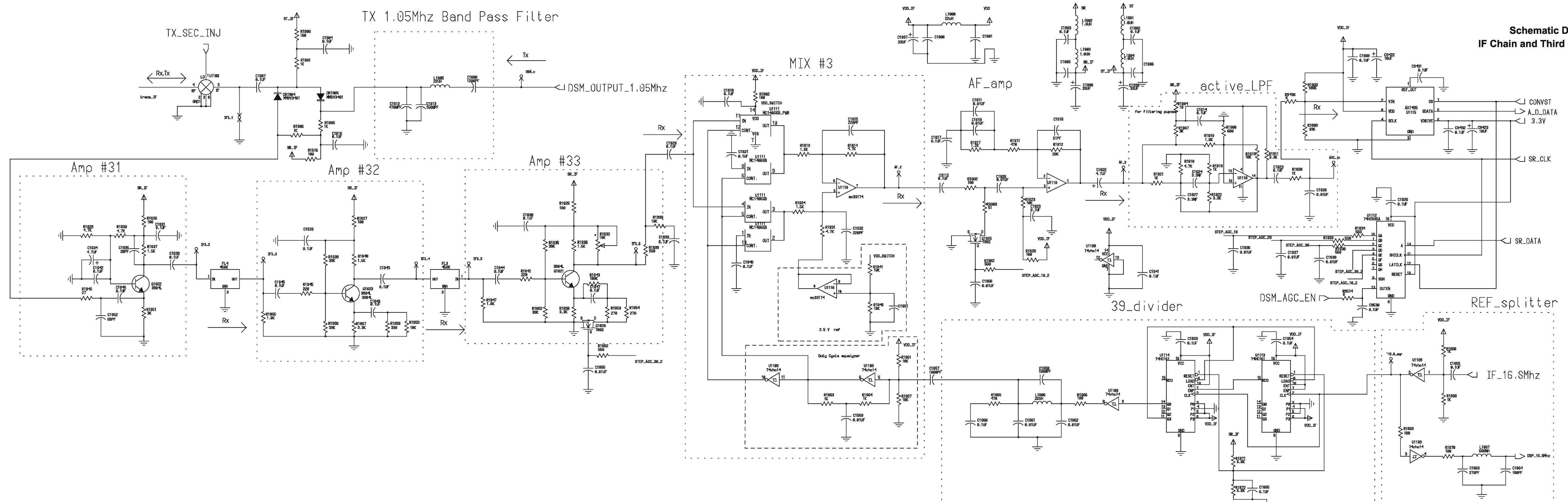

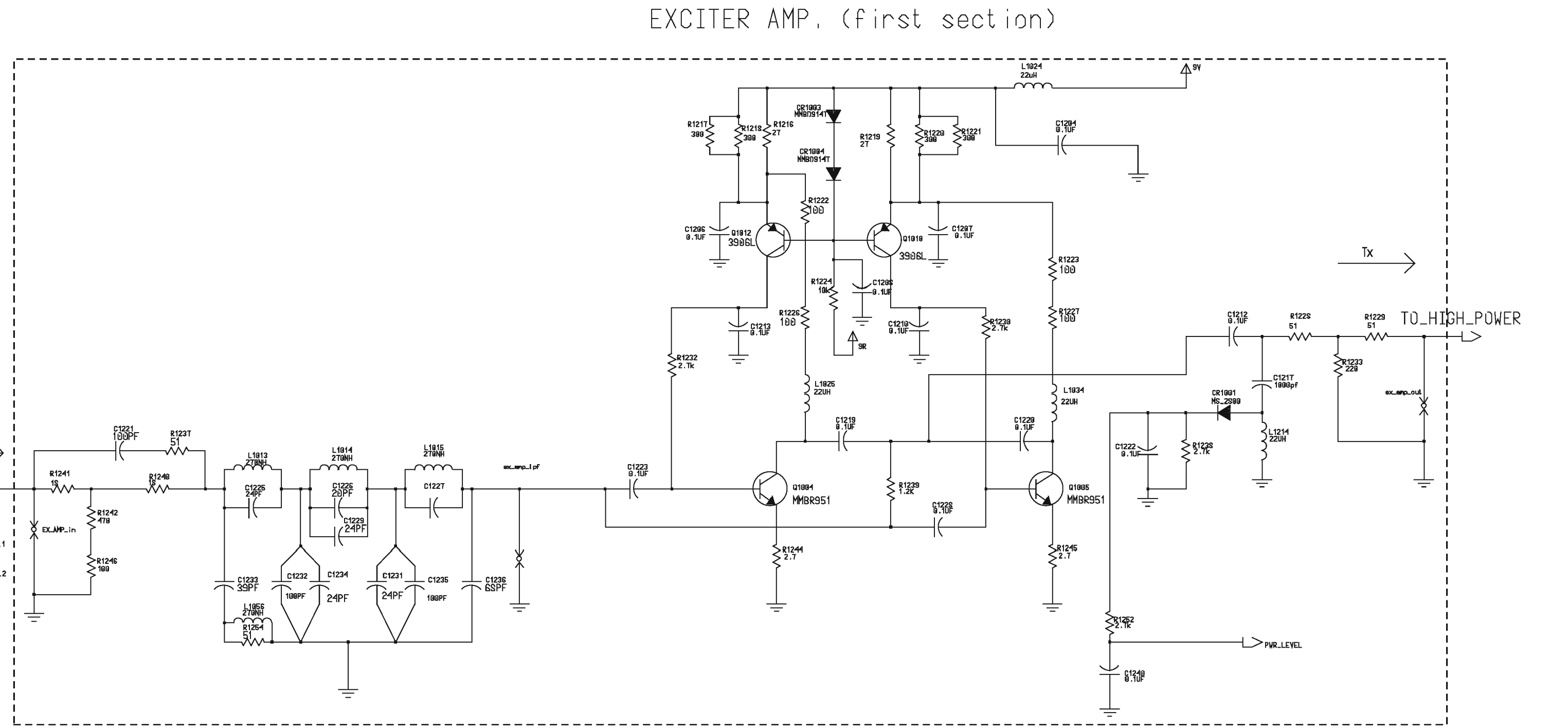
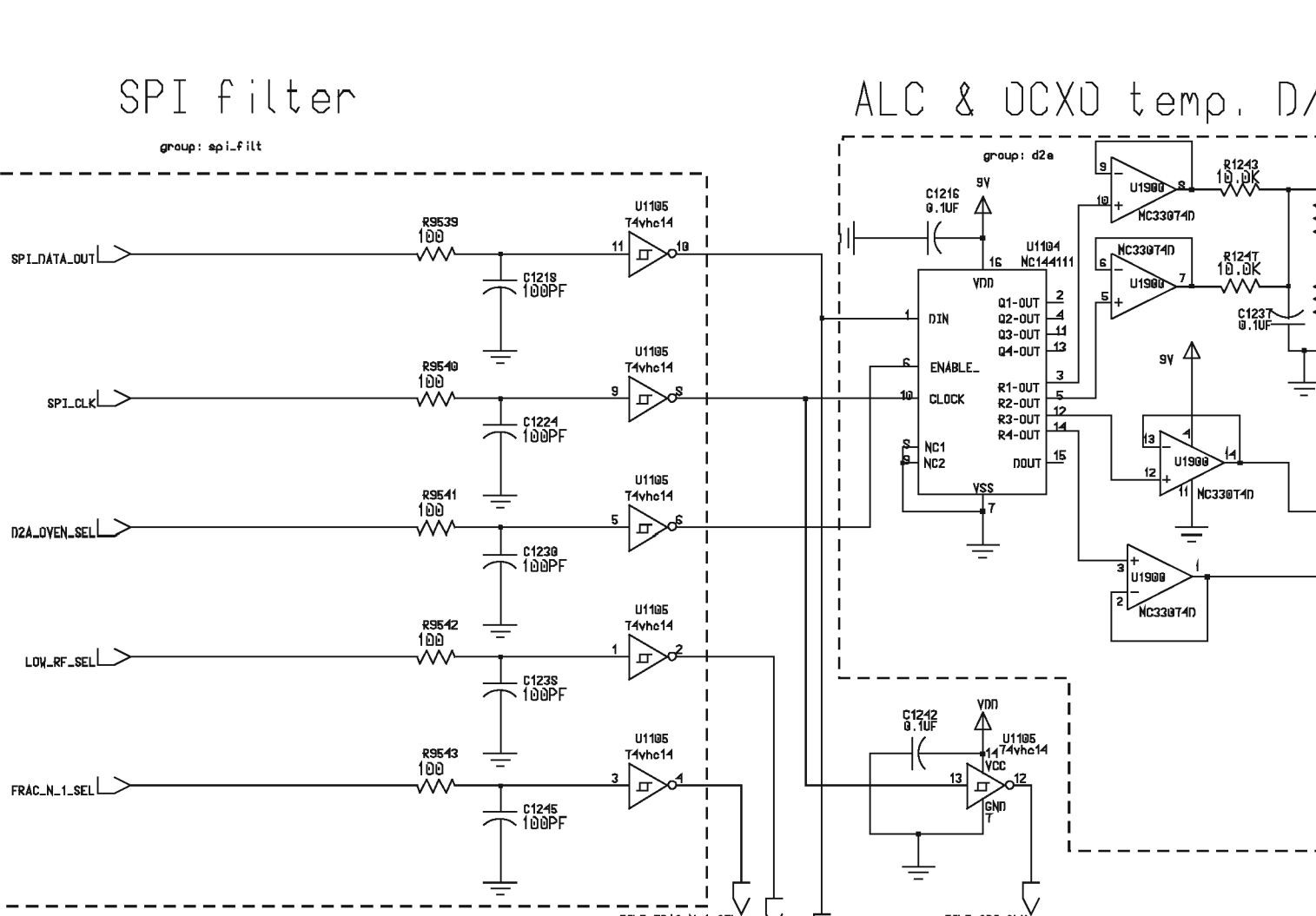
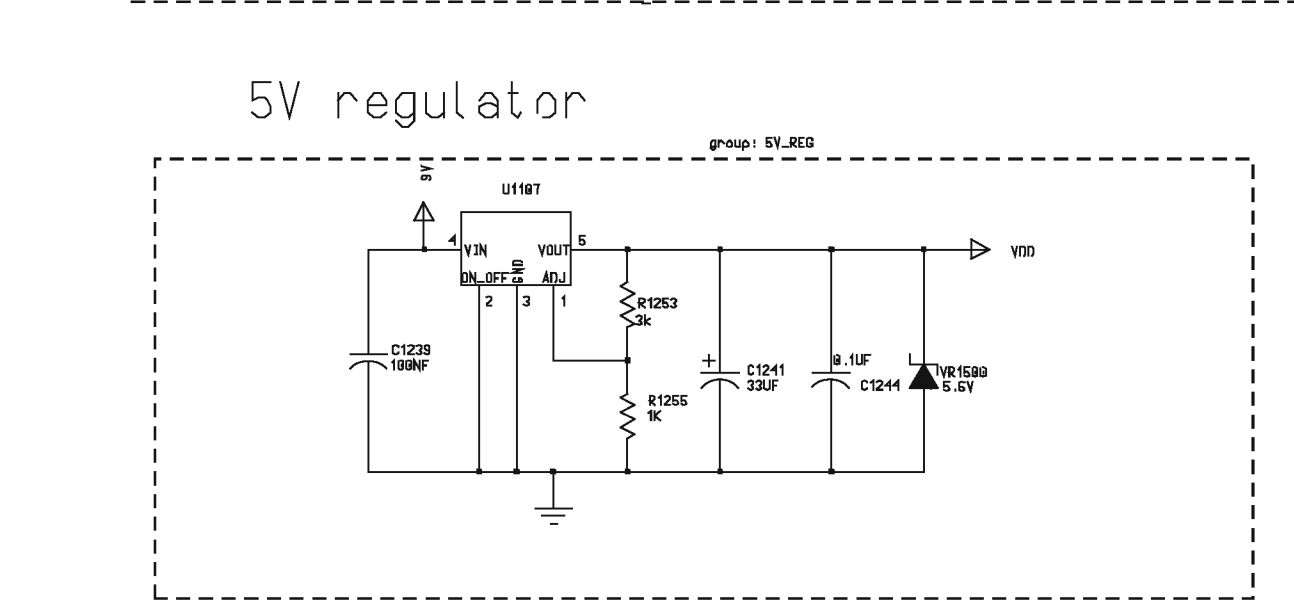
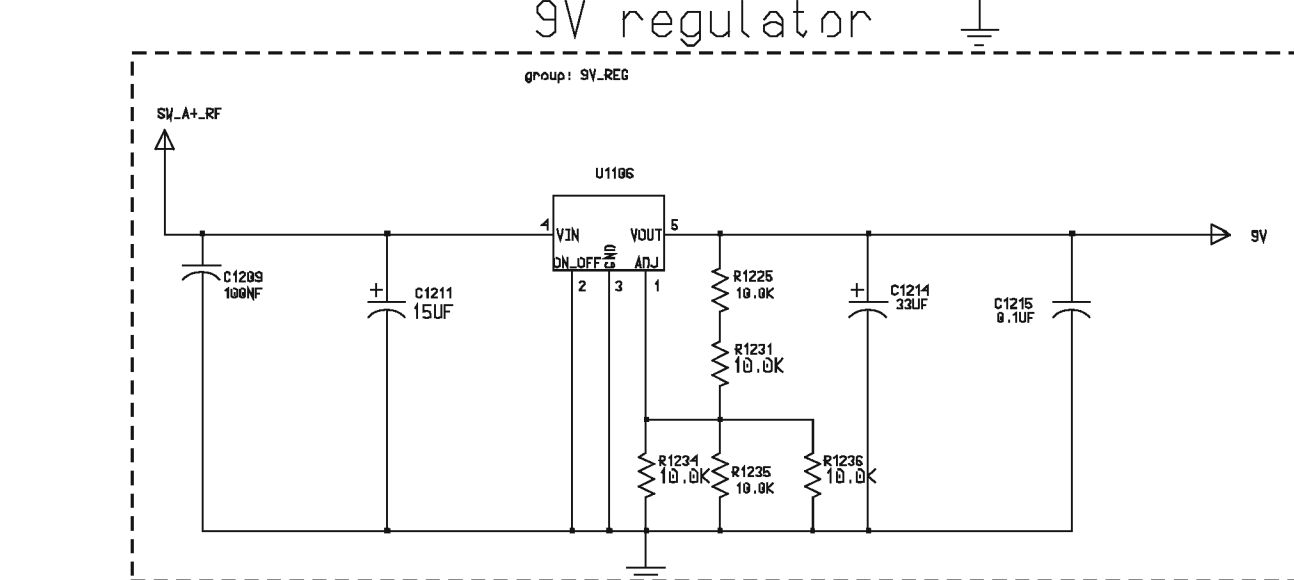
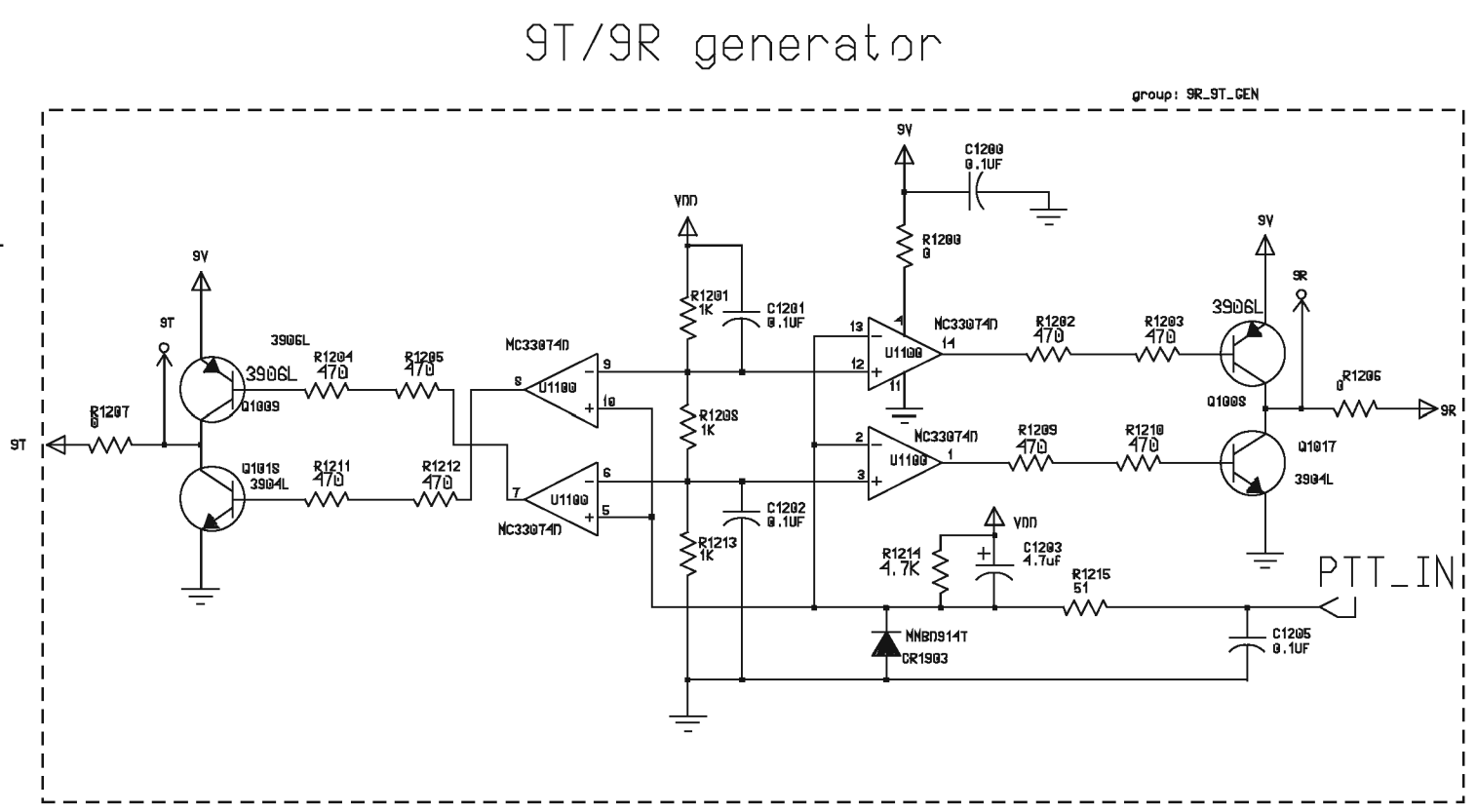
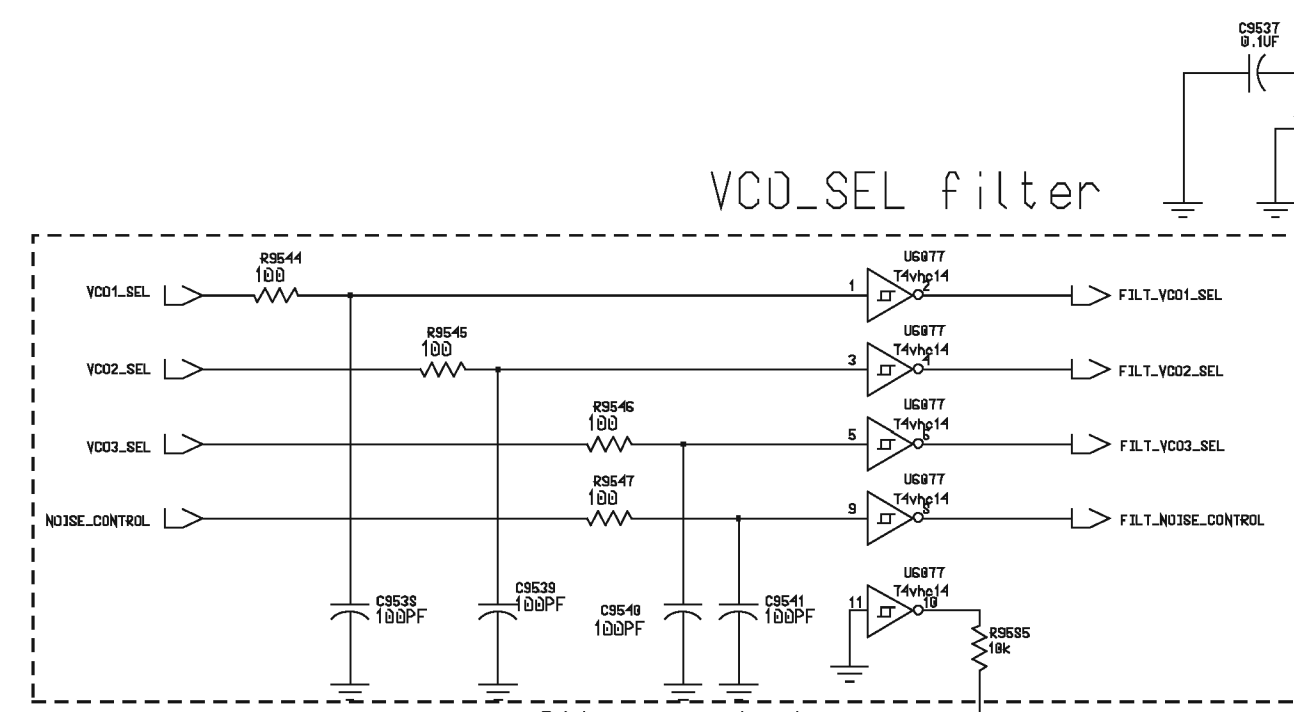

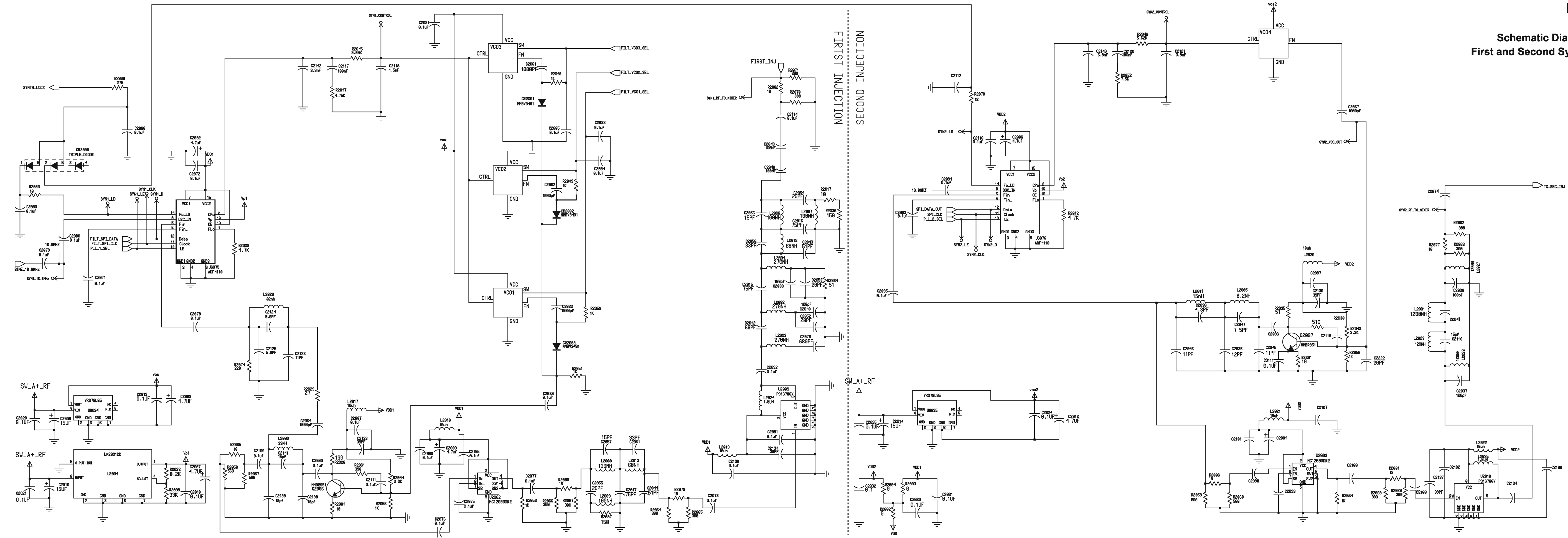

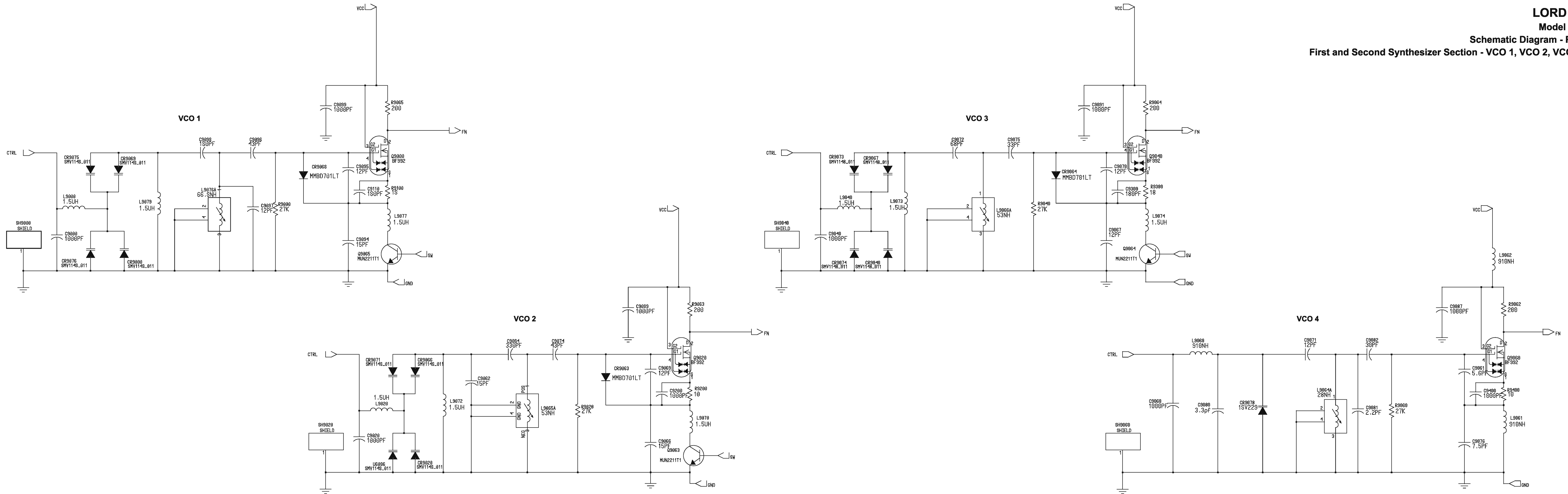

LORD BOARD
Model FTN6067A
Schematic Diagram - RF Section
OCXO Control Section

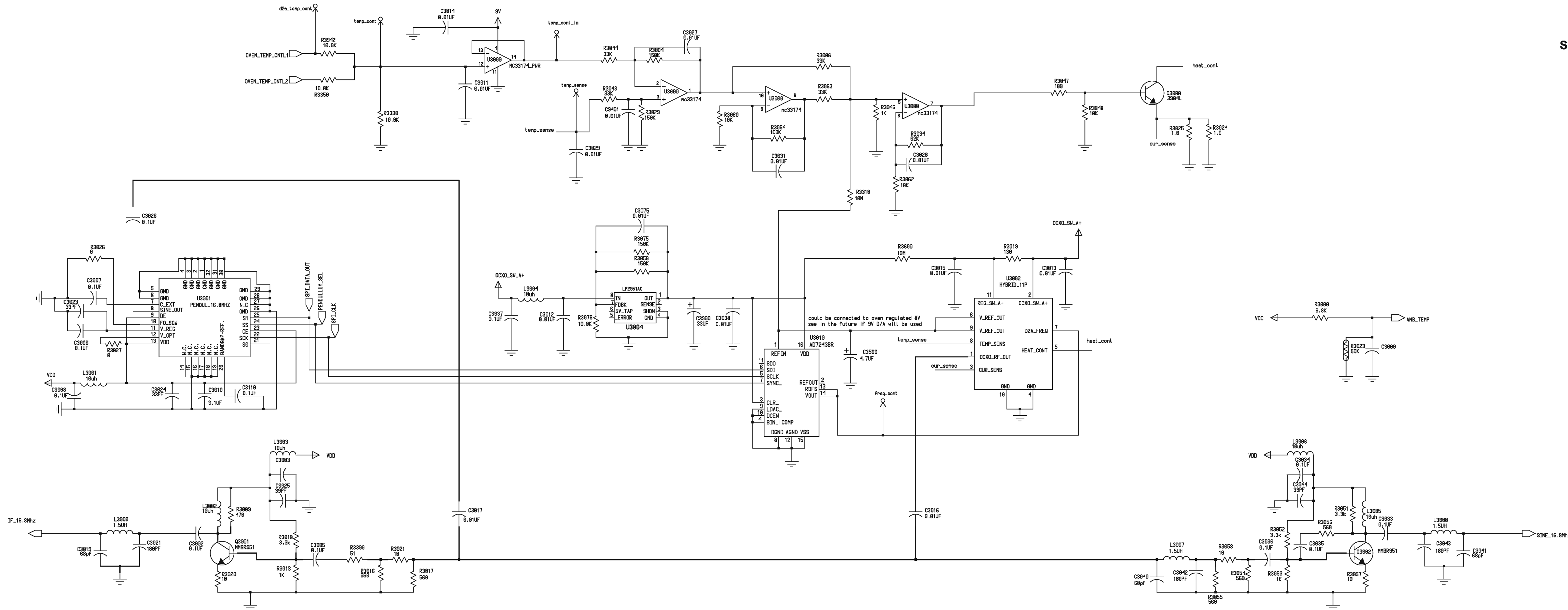

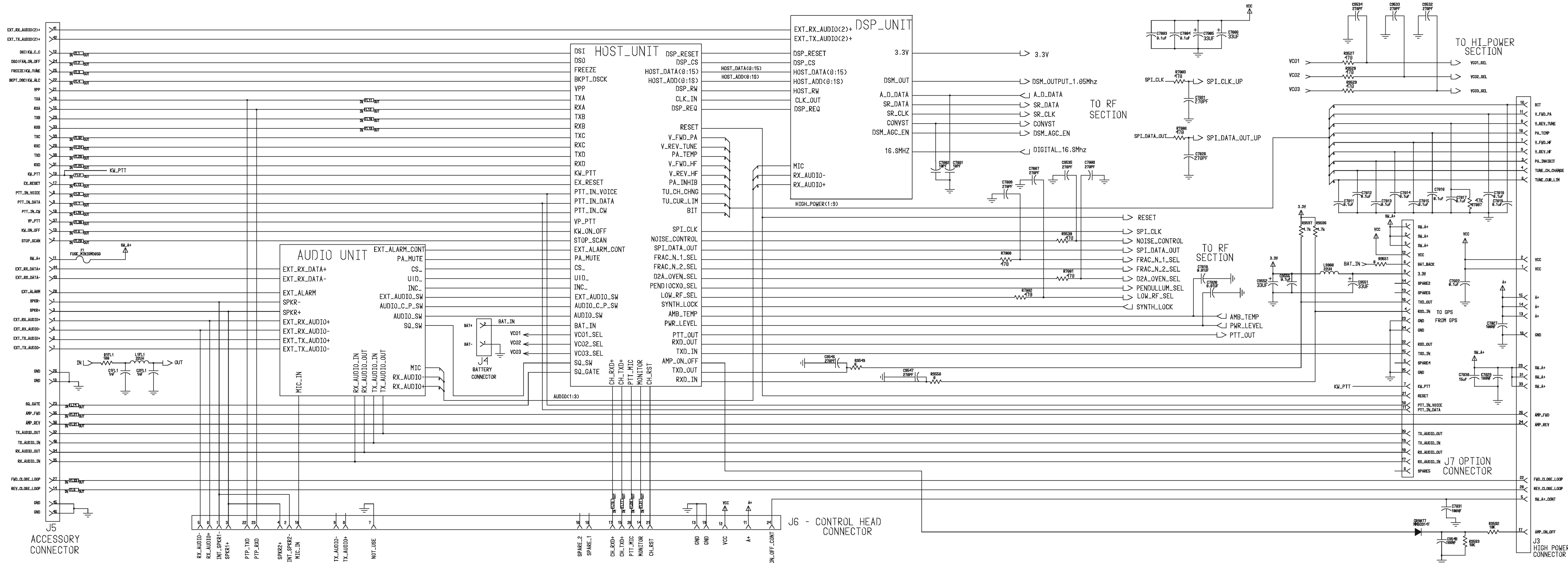

LORD BOARD
Model FTN6067A
Schematic Diagram - CPU and Audio Section
Host Section

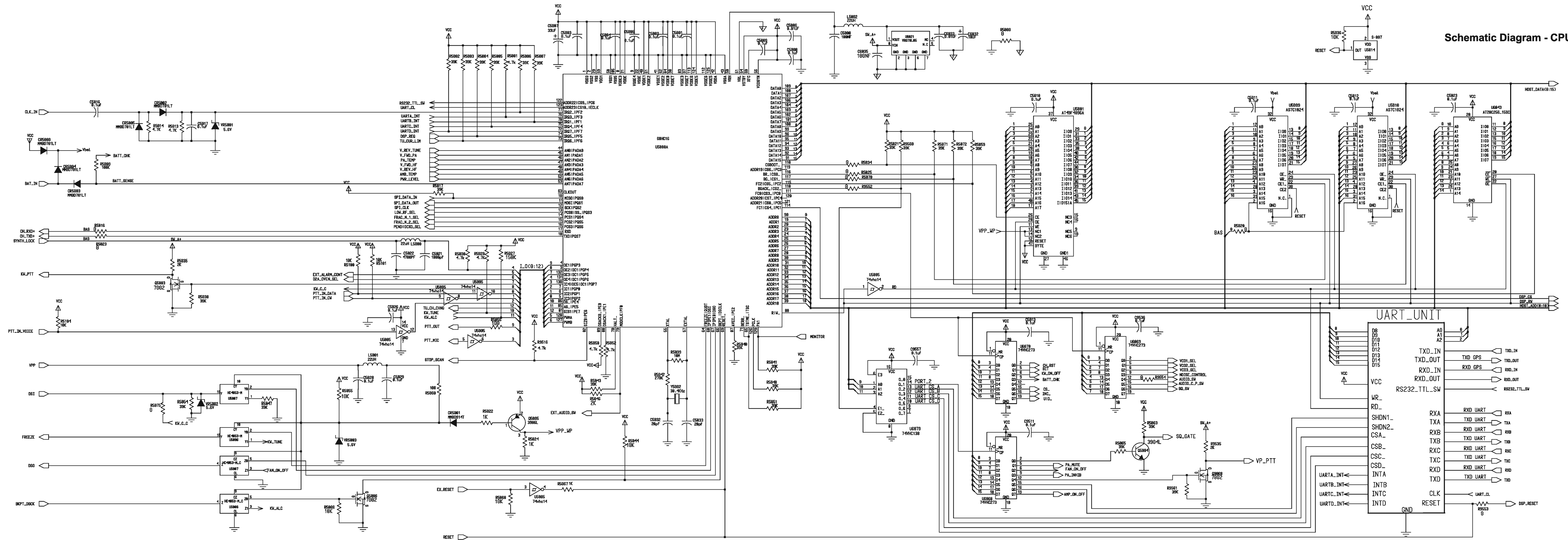

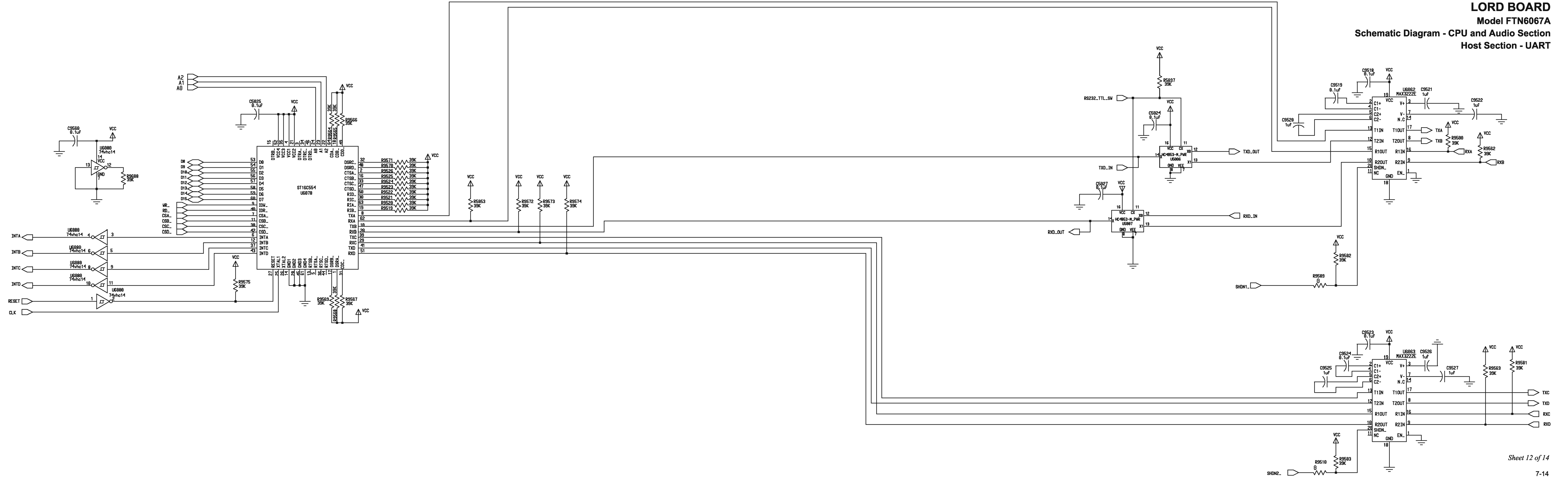

LORD BOARD

Model FTN6067A

Schematic Diagram - CPU and Audio Section
DSP Section

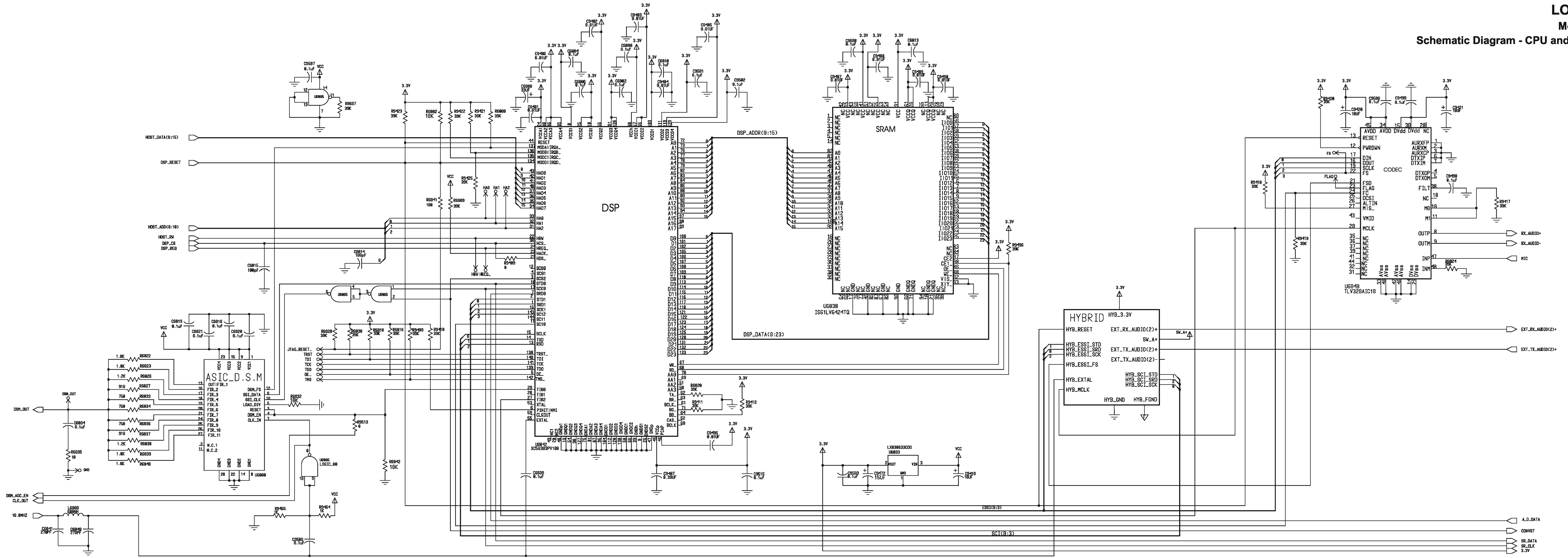

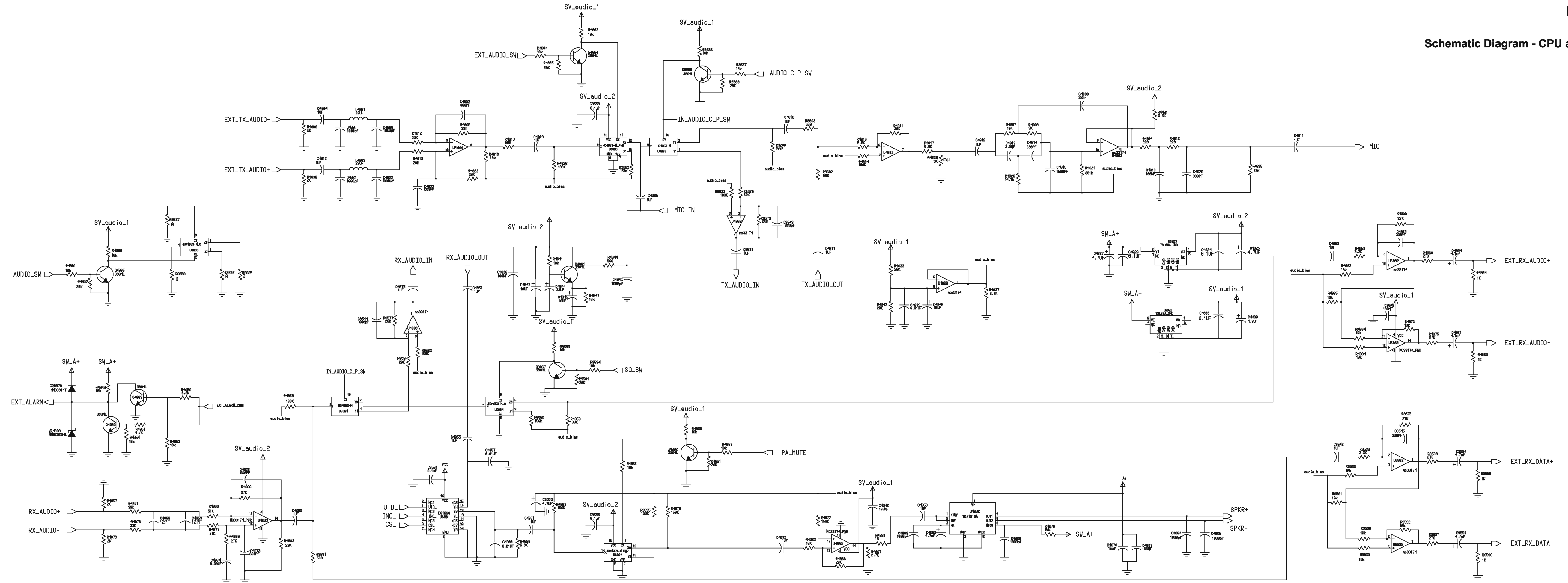

Table 7-1. FTN6067A, LORD Board, Parts List

Reference Designation	Part No.	Description
BL1	2072-32200-00	PCB LORD FOR MICOM-3
C1	2072-17107-00	CAP TANT CHIP 33UF 16V
C2	2072-17107-00	CAP TANT CHIP 33UF 16V
C3	2072-17105-00	CAP TANT CHIP 15UF 25V
C4	4017-20284-00	CAP CHIP X7R 100NF 16V
C6	4017-20284-00	CAP CHIP X7R 100NF 16V
C7	4017-20284-00	CAP CHIP X7R 100NF 16V
C8	4017-20284-00	CAP CHIP X7R 100NF 16V
C9	4017-20284-00	CAP CHIP X7R 100NF 16V
C10	4017-20284-00	CAP CHIP X7R 100NF 16V
C11	4017-20284-00	CAP CHIP X7R 100NF 16V
C12	4017-20284-00	CAP CHIP X7R 100NF 16V
C13	4017-20284-00	CAP CHIP X7R 100NF 16V
C14	4017-20284-00	CAP CHIP X7R 100NF 16V
C15	4017-20284-00	CAP CHIP X7R 100NF 16V
C16	4017-20284-00	CAP CHIP X7R 100NF 16V
C17	4017-20284-00	CAP CHIP X7R 100NF 16V
C18	4017-20284-00	CAP CHIP X7R 100NF 16V
C19	4017-20284-00	CAP CHIP X7R 100NF 16V
C20	4017-20284-00	CAP CHIP X7R 100NF 16V
C21	4017-20284-00	CAP CHIP X7R 100NF 16V
C22	4017-20284-00	CAP CHIP X7R 100NF 16V
C23	4017-20284-00	CAP CHIP X7R 100NF 16V
C24	4017-20284-00	CAP CHIP X7R 100NF 16V
C25	4017-20284-00	CAP CHIP X7R 100NF 16V
C26	4017-20284-00	CAP CHIP X7R 100NF 16V
C27	4017-20271-00	CAP CHIP X7R 10NF 10%
C28	4017-20271-00	CAP CHIP X7R 10NF 10%
C29	2072-17032-00	CAP CHIP X7R 3.3NF
C30	2072-17032-00	CAP CHIP X7R 3.3NF
C31	4017-20267-00	CAP CHIP X7R 4.7NF 10%
C34	2072-17025-00	CAP CHIP X7R 2.7NF
C36	2072-17025-00	CAP CHIP X7R 2.7NF
C37	2072-17031-00	CAP CHIP X7R 1.8NF
C38	2072-17031-00	CAP CHIP X7R 1.8NF
C39	2072-17031-00	CAP CHIP X7R 1.8NF
C40	2072-17031-00	CAP CHIP X7R 1.8NF
C41	2072-17031-00	CAP CHIP X7R 1.8NF
C42	4017-20261-00	CAP 0603 X7R 1.5N 50V
C43	4017-20261-00	CAP 0603 X7R 1.5N 50V
C44	2072-17030-00	CAP CHIP X7R 1.2NF
C45	4017-25282-00	CAP CHIP CG 1NF 5%
C46	4017-25282-00	CAP CHIP CG 1NF 5%
C47	4017-25282-00	CAP CHIP CG 1NF 5%
C48	2072-17029-00	CAP CHIP X7R 680PF
C49	2072-17029-00	CAP CHIP X7R 680PF

Table 7-1. FTN6067A, LORD Board, Parts List

Reference Designation	Part No.	Description
C50	2072-17029-00	CAP CHIP X7R 680PF
C51	2072-17028-00	CAP CHIP X7R 620PF
C52	4017-25279-00	CAP CHIP CG 470PF 5%
C54	4017-25279-00	CAP CHIP CG 470PF 5%
C56	4017-20284-00	CAP CHIP X7R 100NF 16V
C58	2072-17026-00	CAP CHIP X7R 6.8NF
C60	4017-25279-00	CAP CHIP CG 470PF 5%
C61	4017-25279-00	CAP CHIP CG 470PF 5%
C62	4017-25276-00	CAP CHIP CG 270PF 5%
C65	4017-25274-00	CAP 0603 NPO 180P 50V
C66	4017-25269-00	CAP 0603 NPO 68P 50V
C67	4017-25269-00	CAP 0603 NPO 68P 50V
C72	4017-25276-00	CAP CHIP CG 270PF 5%
C77	2072-17056-00	CAP CHIP CL1 +/-30 120P
C78	2072-17056-00	CAP CHIP CL1 +/-30 120P
C79	4017-25081-00	CAP CHIP CER COG 680PF
C80	4017-25075-00	CAP CHIP CER COG 220PF
C81	4017-20271-00	CAP CHIP X7R 10NF 10%
C82	2072-17025-00	CAP CHIP X7R 2.7NF
C83	4017-20284-00	CAP CHIP X7R 100NF 16V
C84	4017-20284-00	CAP CHIP X7R 100NF 16V
C85	4017-20284-00	CAP CHIP X7R 100NF 16V
C86	4017-20284-00	CAP CHIP X7R 100NF 16V
C87	4017-20284-00	CAP CHIP X7R 100NF 16V
C88	4017-25062-00	CAP CHIP CER COG 18PF
C89	4017-20284-00	CAP CHIP X7R 100NF 16V
C90	4017-20284-00	CAP CHIP X7R 100NF 16V
C91	4017-20284-00	CAP CHIP X7R 100NF 16V
C92	4017-20271-00	CAP CHIP X7R 10NF 10%
C93	4017-20271-00	CAP CHIP X7R 10NF 10%
C94	2072-17030-00	CAP CHIP X7R 1.2NF
C95	4017-25279-00	CAP CHIP CG 470PF 5%
C96	4017-25279-00	CAP CHIP CG 470PF 5%
C97	4017-25279-00	CAP CHIP CG 470PF 5%
C98	4017-25279-00	CAP CHIP CG 470PF 5%
C99	4017-25279-00	CAP CHIP CG 470PF 5%
C100	2072-17032-00	CAP CHIP X7R 3.3NF
C101	2072-17025-00	CAP CHIP X7R 2.7NF
C102	2072-17025-00	CAP CHIP X7R 2.7NF
C103	4017-25276-00	CAP CHIP CG 270PF 5%
C104	4017-25276-00	CAP CHIP CG 270PF 5%
C105	4017-25276-00	CAP CHIP CG 270PF 5%
C106	4017-25274-00	CAP 0603 NPO 180P 50V
C107	2072-17009-00	CAP CHIP 1206 390PF 5%
C108	2072-17009-00	CAP CHIP 1206 390PF 5%
C109	2072-17056-00	CAP CHIP CL1 +/-30 120P
C110	4017-25075-00	CAP CHIP CER COG 220PF

Table 7-1. FTN6067A, LORD Board, Parts List

Reference Designation	Part No.	Description
C111	4017-25282-00	CAP CHIP CG 1NF 5%
C112	4017-20284-00	CAP CHIP X7R 100NF 16V
C129	2072-17032-00	CAP CHIP X7R 3.3NF
C130	2072-17032-00	CAP CHIP X7R 3.3NF
C160	4017-25271-00	CAP CHIP CG 100PF 5%
C172	4017-25265-00	CAP CHIP 0603 NPO 33PF
C179	4017-25271-00	CAP CHIP CG 100PF 5%
C200	4017-20284-00	CAP CHIP X7R 100NF 16V
C300	4017-20284-00	CAP CHIP X7R 100NF 16V
C1000	4017-20284-00	CAP CHIP X7R 100NF 16V
C1001	4017-20284-00	CAP CHIP X7R 100NF 16V
C1002	4017-20284-00	CAP CHIP X7R 100NF 16V
C1003	2072-17107-00	CAP TANT CHIP 33UF 16V
C1004	4017-20284-00	CAP CHIP X7R 100NF 16V
C1005	4017-20284-00	CAP CHIP X7R 100NF 16V
C1006	4017-20284-00	CAP CHIP X7R 100NF 16V
C1007	4017-20284-00	CAP CHIP X7R 100NF 16V
C1008	2072-17107-00	CAP TANT CHIP 33UF 16V
C1009	4017-20284-00	CAP CHIP X7R 100NF 16V
C1010	4017-20284-00	CAP CHIP X7R 100NF 16V
C1011	4017-20171-00	CAP CHIP X7R 10NF 100V
C1012	4017-20284-00	CAP CHIP X7R 100NF 16V
C1013	4017-20284-00	CAP CHIP X7R 100NF 16V
C1014	4017-20284-00	CAP CHIP X7R 100NF 16V
C1015	2072-17107-00	CAP TANT CHIP 33UF 16V
C1016	4017-20171-00	CAP CHIP X7R 10NF 100V
C1017	4017-20284-00	CAP CHIP X7R 100NF 16V
C1018	4017-20171-00	CAP CHIP X7R 10NF 100V
C1019	4017-20171-00	CAP CHIP X7R 10NF 100V
C1020	4017-20284-00	CAP CHIP X7R 100NF 16V
C1021	4017-20284-00	CAP CHIP X7R 100NF 16V
C1022	4017-20284-00	CAP CHIP X7R 100NF 16V
C1023	4017-20284-00	CAP CHIP X7R 100NF 16V
C1024	4017-20284-00	CAP CHIP X7R 100NF 16V
C1025	4017-20284-00	CAP CHIP X7R 100NF 16V
C1026	4017-20171-00	CAP CHIP X7R 10NF 100V
C1027	4017-20284-00	CAP CHIP X7R 100NF 16V
C1028	4017-20284-00	CAP CHIP X7R 100NF 16V
C1029	4017-25061-00	CAP CHIP CER COG 15PF
C1030	2072-17002-00	CAP CHIP 1206 10PF 5%
C1031	4017-20171-00	CAP CHIP X7R 10NF 100V
C1034	4017-20284-00	CAP CHIP X7R 100NF 16V
C1035	4017-25066-00	CAP CHIP CER COG 39PF
C1036	4017-20284-00	CAP CHIP X7R 100NF 16V
C1037	4017-20284-00	CAP CHIP X7R 100NF 16V
C1038	2072-17019-00	CAP CHIP 0603 24PF
C1039	2072-17018-00	CAP CHIP 0603 20PF

Table 7-1. FTN6067A, LORD Board, Parts List

Reference Designation	Part No.	Description
C1040	2072-17019-00	CAP CHIP 0603 24PF
C1041	4017-20284-00	CAP CHIP X7R 100NF 16V
C1042	4017-20284-00	CAP CHIP X7R 100NF 16V
C1043	4017-20171-00	CAP CHIP X7R 10NF 100V
C1044	4017-20284-00	CAP CHIP X7R 100NF 16V
C1045	4017-25265-00	CAP CHIP 0603 NPO 33PF
C1046	4017-20171-00	CAP CHIP X7R 10NF 100V
C1047	4017-25269-00	CAP 0603 NPO 68P 50V
C1048	4017-20284-00	CAP CHIP X7R 100NF 16V
C1049	4017-25271-00	CAP CHIP CG 100PF 5%
C1050	2072-17019-00	CAP CHIP 0603 24PF
C1051	2072-17019-00	CAP CHIP 0603 24PF
C1052	2072-17019-00	CAP CHIP 0603 24PF
C1053	4017-25271-00	CAP CHIP CG 100PF 5%
C1054	2072-17003-00	CAP CHIP 1206 12PF 5%
C1055	4017-25061-00	CAP CHIP CER COG 15PF
C1058	4017-20284-00	CAP CHIP X7R 100NF 16V
C1059	4017-20284-00	CAP CHIP X7R 100NF 16V
C1060	4017-20171-00	CAP CHIP X7R 10NF 100V
C1061	4017-20284-00	CAP CHIP X7R 100NF 16V
C1062	4017-20171-00	CAP CHIP X7R 10NF 100V
C1063	4017-20284-00	CAP CHIP X7R 100NF 16V
C1064	4017-20284-00	CAP CHIP X7R 100NF 16V
C1065	4017-20284-00	CAP CHIP X7R 100NF 16V
C1066	2072-17107-00	CAP TANT CHIP 33UF 16V
C1067	4017-20171-00	CAP CHIP X7R 10NF 100V
C1068	4017-20284-00	CAP CHIP X7R 100NF 16V
C1069	4017-20284-00	CAP CHIP X7R 100NF 16V
C1070	2072-17017-00	CAP CHIP 0603 11PF
C1071	2072-17017-00	CAP CHIP 0603 11PF
C1072	4017-20284-00	CAP CHIP X7R 100NF 16V
C1073	4017-20284-00	CAP CHIP X7R 100NF 16V
C1074	4017-20284-00	CAP CHIP X7R 100NF 16V
C1075	2072-17056-00	CAP CHIP CL1 +/-30 120P
C1076	4017-25265-00	CAP CHIP 0603 NPO 33PF
C1077	4017-20171-00	CAP CHIP X7R 10NF 100V
C1078	4017-20284-00	CAP CHIP X7R 100NF 16V
C1079	4017-20284-00	CAP CHIP X7R 100NF 16V
C1080	4017-20284-00	CAP CHIP X7R 100NF 16V
C1081	4017-20284-00	CAP CHIP X7R 100NF 16V
C1082	4017-20284-00	CAP CHIP X7R 100NF 16V
C1083	4017-20284-00	CAP CHIP X7R 100NF 16V
C1084	2072-17107-00	CAP TANT CHIP 33UF 16V
C1160	4017-25252-00	CAP CHIP 2.7PF 50V
C1161	4017-25252-00	CAP CHIP 2.7PF 50V
C1162	4017-25252-00	CAP CHIP 2.7PF 50V
C1163	4017-25252-00	CAP CHIP 2.7PF 50V

Table 7-1. FTN6067A, LORD Board, Parts List

Reference Designation	Part No.	Description
C1200	4017-20284-00	CAP CHIP X7R 100NF 16V
C1201	4017-20284-00	CAP CHIP X7R 100NF 16V
C1202	4017-20284-00	CAP CHIP X7R 100NF 16V
C1203	4017-80125-02	CAP CHIP TAN 4.7UF 25V
C1204	4017-20284-00	CAP CHIP X7R 100NF 16V
C1205	4017-20284-00	CAP CHIP X7R 100NF 16V
C1206	4017-20284-00	CAP CHIP X7R 100NF 16V
C1207	4017-20284-00	CAP CHIP X7R 100NF 16V
C1208	4017-20284-00	CAP CHIP X7R 100NF 16V
C1209	4017-20284-00	CAP CHIP X7R 100NF 16V
C1210	4017-20284-00	CAP CHIP X7R 100NF 16V
C1211	2072-17105-00	CAP TANT CHIP 15UF 25V
C1212	4017-20284-00	CAP CHIP X7R 100NF 16V
C1213	4017-20284-00	CAP CHIP X7R 100NF 16V
C1214	2072-17107-00	CAP TANT CHIP 33UF 16V
C1215	4017-20284-00	CAP CHIP X7R 100NF 16V
C1216	4017-20284-00	CAP CHIP X7R 100NF 16V
C1217	4017-25282-00	CAP CHIP CG 1NF 5%
C1218	4017-25271-00	CAP CHIP CG 100PF 5%
C1219	4017-20284-00	CAP CHIP X7R 100NF 16V
C1220	4017-20284-00	CAP CHIP X7R 100NF 16V
C1221	4017-25271-00	CAP CHIP CG 100PF 5%
C1222	4017-20284-00	CAP CHIP X7R 100NF 16V
C1223	4017-20284-00	CAP CHIP X7R 100NF 16V
C1224	4017-25271-00	CAP CHIP CG 100PF 5%
C1225	2072-17019-00	CAP CHIP 0603 24PF
C1226	2072-17018-00	CAP CHIP 0603 20PF
C1227	2072-17019-00	CAP CHIP 0603 24PF
C1228	4017-20284-00	CAP CHIP X7R 100NF 16V
C1229	2072-17019-00	CAP CHIP 0603 24PF
C1230	4017-25271-00	CAP CHIP CG 100PF 5%
C1231	2072-17019-00	CAP CHIP 0603 24PF
C1232	4017-25271-00	CAP CHIP CG 100PF 5%
C1233	4017-25066-00	CAP CHIP CER COG 39PF
C1234	2072-17019-00	CAP CHIP 0603 24PF
C1235	4017-25271-00	CAP CHIP CG 100PF 5%
C1236	4017-25269-00	CAP 0603 NPO 68P 50V
C1237	4017-20284-00	CAP CHIP X7R 100NF 16V
C1238	4017-25271-00	CAP CHIP CG 100PF 5%
C1239	4017-20284-00	CAP CHIP X7R 100NF 16V
C1240	4017-20284-00	CAP CHIP X7R 100NF 16V
C1241	2072-17107-00	CAP TANT CHIP 33UF 16V
C1242	4017-20284-00	CAP CHIP X7R 100NF 16V
C1244	4017-20284-00	CAP CHIP X7R 100NF 16V
C1245	4017-25271-00	CAP CHIP CG 100PF 5%
C1800	4017-20284-00	CAP CHIP X7R 100NF 16V
C1801	4017-20284-00	CAP CHIP X7R 100NF 16V

Table 7-1. FTN6067A, LORD Board, Parts List

Reference Designation	Part No.	Description
C1802	4017-20284-00	CAP CHIP X7R 100NF 16V
C1803	4017-20284-00	CAP CHIP X7R 100NF 16V
C1804	4017-20284-00	CAP CHIP X7R 100NF 16V
C1805	4017-20284-00	CAP CHIP X7R 100NF 16V
C1806	4017-20284-00	CAP CHIP X7R 100NF 16V
C1807	4017-20284-00	CAP CHIP X7R 100NF 16V
C1808	2072-17030-00	CAP CHIP X7R 1.2NF
C1809	4017-20284-00	CAP CHIP X7R 100NF 16V
C1810	4017-20284-00	CAP CHIP X7R 100NF 16V
C1811	4017-20271-00	CAP CHIP X7R 10NF 10%
C1812	4017-20267-00	CAP CHIP X7R 4.7NF 10%
C1813	4017-20261-00	CAP 0603 X7R 1.5N 50V
C1814	4017-20284-00	CAP CHIP X7R 100NF 16V
C1815	4017-25075-00	CAP CHIP CER COG 220PF
C1816	2072-17020-00	CAP CHIP 0603 51PF
C1817	4017-20284-00	CAP CHIP X7R 100NF 16V
C1818	4017-20284-00	CAP CHIP X7R 100NF 16V
C1819	4017-20271-00	CAP CHIP X7R 10NF 10%
C1820	4017-20284-00	CAP CHIP X7R 100NF 16V
C1821	4017-20284-00	CAP CHIP X7R 100NF 16V
C1822	4017-80125-02	CAP CHIP TAN 4.7UF 25V
C1823	4017-20284-00	CAP CHIP X7R 100NF 16V
C1824	2072-17032-00	CAP CHIP X7R 3.3NF
C1825	4017-20271-00	CAP CHIP X7R 10NF 10%
C1826	4017-20271-00	CAP CHIP X7R 10NF 10%
C1827	2072-17032-00	CAP CHIP X7R 3.3NF
C1828	4017-20284-00	CAP CHIP X7R 100NF 16V
C1829	4017-20284-00	CAP CHIP X7R 100NF 16V
C1830	4017-20284-00	CAP CHIP X7R 100NF 16V
C1831	4017-20284-00	CAP CHIP X7R 100NF 16V
C1832	4017-25075-00	CAP CHIP CER COG 220PF
C1833	4017-20284-00	CAP CHIP X7R 100NF 16V
C1834	4017-80125-02	CAP CHIP TAN 4.7UF 25V
C1835	2072-17018-00	CAP CHIP 0603 20PF
C1836	4017-20271-00	CAP CHIP X7R 10NF 10%
C1837	4017-20271-00	CAP CHIP X7R 10NF 10%
C1838	4017-20284-00	CAP CHIP X7R 100NF 16V
C1839	4017-20271-00	CAP CHIP X7R 10NF 10%
C1840	4017-20284-00	CAP CHIP X7R 100NF 16V
C1841	4017-20284-00	CAP CHIP X7R 100NF 16V
C1842	4017-20284-00	CAP CHIP X7R 100NF 16V
C1843	4017-20284-00	CAP CHIP X7R 100NF 16V
C1844	4017-20284-00	CAP CHIP X7R 100NF 16V
C1845	4017-20284-00	CAP CHIP X7R 100NF 16V
C1846	4017-20284-00	CAP CHIP X7R 100NF 16V
C1847	4017-20284-00	CAP CHIP X7R 100NF 16V
C1848	4017-20284-00	CAP CHIP X7R 100NF 16V

Table 7-1. FTN6067A, LORD Board, Parts List

Reference Designation	Part No.	Description
C1851	4017-20284-00	CAP CHIP X7R 100NF 16V
C1852	4017-25269-00	CAP 0603 NPO 68P 50V
C1853	4017-20284-00	CAP CHIP X7R 100NF 16V
C1854	4017-20284-00	CAP CHIP X7R 100NF 16V
C1855	4017-20284-00	CAP CHIP X7R 100NF 16V
C1856	4017-20271-00	CAP CHIP X7R 10NF 10%
C1857	4017-25282-00	CAP CHIP CG 1NF 5%
C1858	4017-25282-00	CAP CHIP CG 1NF 5%
C1859	4017-20271-00	CAP CHIP X7R 10NF 10%
C1860	4017-20284-00	CAP CHIP X7R 100NF 16V
C1861	4017-20271-00	CAP CHIP X7R 10NF 10%
C1862	4017-20271-00	CAP CHIP X7R 10NF 10%
C1863	4017-25276-00	CAP CHIP CG 270PF 5%
C1864	4017-25274-00	CAP 0603 NPO 180P 50V
C1865	4017-20284-00	CAP CHIP X7R 100NF 16V
C1890	4017-20284-00	CAP CHIP X7R 100NF 16V
C1956	4017-20271-00	CAP CHIP X7R 10NF 10%
C1997	2072-17107-00	CAP TANT CHIP 33UF 16V
C1998	2072-17107-00	CAP TANT CHIP 33UF 16V
C1999	2072-17107-00	CAP TANT CHIP 33UF 16V
C1FL1	4017-20559-00	CAP CHIP X7R 1NF 10%
C1FL2	4017-20559-00	CAP CHIP X7R 1NF 10%
C1FL3	4017-20559-00	CAP CHIP X7R 1NF 10%
C1FL4	4017-20559-00	CAP CHIP X7R 1NF 10%
C1FL5	4017-20559-00	CAP CHIP X7R 1NF 10%
C1FL6	4017-20559-00	CAP CHIP X7R 1NF 10%
C1FL7	4017-20559-00	CAP CHIP X7R 1NF 10%
C1FL8	4017-20559-00	CAP CHIP X7R 1NF 10%
C1FL9	4017-20559-00	CAP CHIP X7R 1NF 10%
C1FL10	4017-20559-00	CAP CHIP X7R 1NF 10%
C1FL11	4017-20559-00	CAP CHIP X7R 1NF 10%
C1FL12	4017-20559-00	CAP CHIP X7R 1NF 10%
C1FL13	4017-20559-00	CAP CHIP X7R 1NF 10%
C1FL14	4017-20559-00	CAP CHIP X7R 1NF 10%
C1FL15	4017-20559-00	CAP CHIP X7R 1NF 10%
C1FL17	4017-20559-00	CAP CHIP X7R 1NF 10%
C1FL18	4017-20559-00	CAP CHIP X7R 1NF 10%
C1FL19	4017-20559-00	CAP CHIP X7R 1NF 10%
C1FL20	4017-20559-00	CAP CHIP X7R 1NF 10%
C1FL21	4017-20559-00	CAP CHIP X7R 1NF 10%
C1FL23	4017-25282-00	CAP CHIP CG 1NF 5%
C1FL24	4017-25282-00	CAP CHIP CG 1NF 5%
C1FL27	4017-20559-00	CAP CHIP X7R 1NF 10%
C1FL28	4017-20559-00	CAP CHIP X7R 1NF 10%
C1FL29	4017-25282-00	CAP CHIP CG 1NF 5%
C1FL30	4017-20559-00	CAP CHIP X7R 1NF 10%
C1FL31	4017-20559-00	CAP CHIP X7R 1NF 10%

Table 7-1. FTN6067A, LORD Board, Parts List

Reference Designation	Part No.	Description
C1FL32	4017-25282-00	CAP CHIP CG 1NF 5%
C1FL33	4017-20559-00	CAP CHIP X7R 1NF 10%
C2000	4017-20284-00	CAP CHIP X7R 100NF 16V
C2002	4017-80125-02	CAP CHIP TAN 4.7UF 25V
C2003	4017-80125-02	CAP CHIP TAN 4.7UF 25V
C2004	4017-80125-02	CAP CHIP TAN 4.7UF 25V
C2006	4017-80125-02	CAP CHIP TAN 4.7UF 25V
C2007	4017-80125-02	CAP CHIP TAN 4.7UF 25V
C2008	4017-80125-02	CAP CHIP TAN 4.7UF 25V
C2009	2072-17105-00	CAP TANT CHIP 15UF 25V
C2010	2072-17105-00	CAP TANT CHIP 15UF 25V
C2013	4017-80125-02	CAP CHIP TAN 4.7UF 25V
C2014	2072-17105-00	CAP TANT CHIP 15UF 25V
C2015	2072-17021-00	CAP CHIP 0603 75PF
C2016	2072-17021-00	CAP CHIP 0603 75PF
C2017	2072-17021-00	CAP CHIP 0603 75PF
C2018	4017-20183-00	CAP 1812 X7R 100N 100V
C2019	4017-20183-00	CAP 1812 X7R 100N 100V
C2020	4017-20183-00	CAP 1812 X7R 100N 100V
C2021	4017-20183-00	CAP 1812 X7R 100N 100V
C2024	4017-20183-00	CAP 1812 X7R 100N 100V
C2025	4017-20183-00	CAP 1812 X7R 100N 100V
C2030	4017-20284-00	CAP CHIP X7R 100NF 16V
C2031	4017-20284-00	CAP CHIP X7R 100NF 16V
C2032	4017-20284-00	CAP CHIP X7R 100NF 16V
C2035	4017-25260-00	CAP 0603 NPO 12P 50V
C2036	2072-17015-00	CAP CHIP 0603 4.3PF
C2037	4017-25271-00	CAP CHIP CG 100PF 5%
C2038	4017-25271-00	CAP CHIP CG 100PF 5%
C2039	4017-25271-00	CAP CHIP CG 100PF 5%
C2040	4017-25271-00	CAP CHIP CG 100PF 5%
C2041	4017-25269-00	CAP 0603 NPO 68P 50V
C2042	4017-25269-00	CAP 0603 NPO 68P 50V
C2043	2072-17020-00	CAP CHIP 0603 51PF
C2044	2072-17020-00	CAP CHIP 0603 51PF
C2045	2072-17017-00	CAP CHIP 0603 11PF
C2046	2072-17017-00	CAP CHIP 0603 11PF
C2047	2072-17016-00	CAP CHIP 0603 7.5PF
C2048	4017-20284-00	CAP CHIP X7R 100NF 16V
C2049	4017-20284-00	CAP CHIP X7R 100NF 16V
C2050	4017-25265-00	CAP CHIP 0603 NPO 33PF
C2051	4017-25265-00	CAP CHIP 0603 NPO 33PF
C2052	2072-17018-00	CAP CHIP 0603 20PF
C2053	2072-17018-00	CAP CHIP 0603 20PF
C2054	2072-17018-00	CAP CHIP 0603 20PF
C2055	2072-17018-00	CAP CHIP 0603 20PF
C2056	4017-25261-00	CAP 0603 NPO 15P 50V

Table 7-1. FTN6067A, LORD Board, Parts List

Reference Designation	Part No.	Description
C2057	4017-25261-00	CAP 0603 NPO 15P 50V
C2061	4017-25282-00	CAP CHIP CG 1NF 5%
C2062	4017-25282-00	CAP CHIP CG 1NF 5%
C2063	4017-25282-00	CAP CHIP CG 1NF 5%
C2064	4017-25282-00	CAP CHIP CG 1NF 5%
C2067	4017-25282-00	CAP CHIP CG 1NF 5%
C2070	2072-17029-00	CAP CHIP X7R 680PF
C2071	4017-20284-00	CAP CHIP X7R 100NF 16V
C2072	4017-20284-00	CAP CHIP X7R 100NF 16V
C2073	4017-20284-00	CAP CHIP X7R 100NF 16V
C2074	4017-20284-00	CAP CHIP X7R 100NF 16V
C2075	4017-20284-00	CAP CHIP X7R 100NF 16V
C2076	4017-20284-00	CAP CHIP X7R 100NF 16V
C2077	4017-20284-00	CAP CHIP X7R 100NF 16V
C2078	4017-20284-00	CAP CHIP X7R 100NF 16V
C2079	4017-20284-00	CAP CHIP X7R 100NF 16V
C2080	4017-20284-00	CAP CHIP X7R 100NF 16V
C2081	4017-20284-00	CAP CHIP X7R 100NF 16V
C2083	4017-20284-00	CAP CHIP X7R 100NF 16V
C2084	4017-20284-00	CAP CHIP X7R 100NF 16V
C2085	4017-20284-00	CAP CHIP X7R 100NF 16V
C2086	4017-20284-00	CAP CHIP X7R 100NF 16V
C2087	4017-20284-00	CAP CHIP X7R 100NF 16V
C2088	4017-20284-00	CAP CHIP X7R 100NF 16V
C2089	4017-20284-00	CAP CHIP X7R 100NF 16V
C2090	4017-20284-00	CAP CHIP X7R 100NF 16V
C2091	4017-20284-00	CAP CHIP X7R 100NF 16V
C2092	4017-20284-00	CAP CHIP X7R 100NF 16V
C2093	4017-20284-00	CAP CHIP X7R 100NF 16V
C2094	4017-20284-00	CAP CHIP X7R 100NF 16V
C2095	4017-20284-00	CAP CHIP X7R 100NF 16V
C2096	4017-20284-00	CAP CHIP X7R 100NF 16V
C2097	4017-20284-00	CAP CHIP X7R 100NF 16V
C2098	4017-20284-00	CAP CHIP X7R 100NF 16V
C2099	4017-20284-00	CAP CHIP X7R 100NF 16V
C2100	4017-20284-00	CAP CHIP X7R 100NF 16V
C2101	4017-20284-00	CAP CHIP X7R 100NF 16V
C2102	4017-20284-00	CAP CHIP X7R 100NF 16V
C2103	4017-20284-00	CAP CHIP X7R 100NF 16V
C2104	4017-20284-00	CAP CHIP X7R 100NF 16V
C2105	4017-20284-00	CAP CHIP X7R 100NF 16V
C2106	4017-20284-00	CAP CHIP X7R 100NF 16V
C2107	4017-20284-00	CAP CHIP X7R 100NF 16V
C2108	4017-20284-00	CAP CHIP X7R 100NF 16V
C2109	4017-20284-00	CAP CHIP X7R 100NF 16V
C2110	4017-20284-00	CAP CHIP X7R 100NF 16V
C2111	4017-20284-00	CAP CHIP X7R 100NF 16V

Table 7-1. FTN6067A, LORD Board, Parts List

Reference Designation	Part No.	Description
C2112	4017-20284-00	CAP CHIP X7R 100NF 16V
C2114	4017-20284-00	CAP CHIP X7R 100NF 16V
C2116	4017-20284-00	CAP CHIP X7R 100NF 16V
C2117	4017-20284-00	CAP CHIP X7R 100NF 16V
C2118	4017-20261-00	CAP 0603 X7R 1.5N 50V
C2120	4017-20284-00	CAP CHIP X7R 100NF 16V
C2121	4017-20266-00	CAP CHIP X7R 3.9NF 50V
C2123	2072-17017-00	CAP CHIP 0603 11PF
C2124	4017-25256-00	CAP CHIP 5.6PF 100V
C2125	4017-25256-00	CAP CHIP 5.6PF 100V
C2133	4017-25066-00	CAP CHIP CER COG 39PF
C2134	4017-25066-00	CAP CHIP CER COG 39PF
C2136	4017-25066-00	CAP CHIP CER COG 39PF
C2137	4017-25066-00	CAP CHIP CER COG 39PF
C2138	4017-25062-00	CAP CHIP CER COG 18PF
C2139	4017-25062-00	CAP CHIP CER COG 18PF
C2140	4017-25061-00	CAP CHIP CER COG 15PF
C2141	4017-25061-00	CAP CHIP CER COG 15PF
C2142	4017-20266-00	CAP CHIP X7R 3.9NF 50V
C2146	4017-20269-00	CAP 0603 X7R 6.8NF 50V
C2222	2072-17012-00	CAP CHIP 0805 20PF 5%
C2900	4017-20284-00	CAP CHIP X7R 100NF 16V
C2FL1	4017-20559-00	CAP CHIP X7R 1NF 10%
C2FL2	4017-20559-00	CAP CHIP X7R 1NF 10%
C2FL3	4017-20559-00	CAP CHIP X7R 1NF 10%
C2FL4	4017-20559-00	CAP CHIP X7R 1NF 10%
C2FL5	4017-20559-00	CAP CHIP X7R 1NF 10%
C2FL6	4017-20559-00	CAP CHIP X7R 1NF 10%
C2FL7	4017-20559-00	CAP CHIP X7R 1NF 10%
C2FL8	4017-20559-00	CAP CHIP X7R 1NF 10%
C2FL9	4017-20559-00	CAP CHIP X7R 1NF 10%
C2FL10	4017-20559-00	CAP CHIP X7R 1NF 10%
C2FL11	4017-20559-00	CAP CHIP X7R 1NF 10%
C2FL12	4017-20559-00	CAP CHIP X7R 1NF 10%
C2FL13	4017-20559-00	CAP CHIP X7R 1NF 10%
C2FL14	4017-20559-00	CAP CHIP X7R 1NF 10%
C2FL15	4017-20559-00	CAP CHIP X7R 1NF 10%
C2FL17	4017-20559-00	CAP CHIP X7R 1NF 10%
C2FL18	4017-20559-00	CAP CHIP X7R 1NF 10%
C2FL19	4017-20559-00	CAP CHIP X7R 1NF 10%
C2FL20	4017-20559-00	CAP CHIP X7R 1NF 10%
C2FL21	4017-20559-00	CAP CHIP X7R 1NF 10%
C2FL23	4017-25282-00	CAP CHIP CG 1NF 5%
C2FL24	4017-25282-00	CAP CHIP CG 1NF 5%
C2FL27	4017-20559-00	CAP CHIP X7R 1NF 10%
C2FL28	4017-20559-00	CAP CHIP X7R 1NF 10%
C2FL29	4017-25282-00	CAP CHIP CG 1NF 5%

Table 7-1. FTN6067A, LORD Board, Parts List

Reference Designation	Part No.	Description
C2FL30	4017-20559-00	CAP CHIP X7R 1NF 10%
C2FL31	4017-20559-00	CAP CHIP X7R 1NF 10%
C2FL32	4017-25282-00	CAP CHIP CG 1NF 5%
C2FL33	4017-20559-00	CAP CHIP X7R 1NF 10%
C3000	4017-20271-00	CAP CHIP X7R 10NF 10%
C3002	4017-20284-00	CAP CHIP X7R 100NF 16V
C3003	4017-20284-00	CAP CHIP X7R 100NF 16V
C3005	4017-20284-00	CAP CHIP X7R 100NF 16V
C3006	4017-20284-00	CAP CHIP X7R 100NF 16V
C3007	4017-20284-00	CAP CHIP X7R 100NF 16V
C3008	4017-20284-00	CAP CHIP X7R 100NF 16V
C3010	4017-20284-00	CAP CHIP X7R 100NF 16V
C3011	4017-20271-00	CAP CHIP X7R 10NF 10%
C3012	4017-20271-00	CAP CHIP X7R 10NF 10%
C3013	4017-20271-00	CAP CHIP X7R 10NF 10%
C3014	4017-20271-00	CAP CHIP X7R 10NF 10%
C3015	4017-20271-00	CAP CHIP X7R 10NF 10%
C3016	4017-20271-00	CAP CHIP X7R 10NF 10%
C3017	4017-20271-00	CAP CHIP X7R 10NF 10%
C3019	4017-25269-00	CAP 0603 NPO 68P 50V
C3021	4017-25274-00	CAP 0603 NPO 180P 50V
C3023	4017-25265-00	CAP CHIP 0603 NPO 33PF
C3024	4017-25265-00	CAP CHIP 0603 NPO 33PF
C3025	4017-25066-00	CAP CHIP CER COG 39PF
C3026	4017-20284-00	CAP CHIP X7R 100NF 16V
C3027	4017-20271-00	CAP CHIP X7R 10NF 10%
C3028	4017-20271-00	CAP CHIP X7R 10NF 10%
C3029	4017-20271-00	CAP CHIP X7R 10NF 10%
C3031	4017-20271-00	CAP CHIP X7R 10NF 10%
C3033	4017-20284-00	CAP CHIP X7R 100NF 16V
C3034	4017-20284-00	CAP CHIP X7R 100NF 16V
C3035	4017-20284-00	CAP CHIP X7R 100NF 16V
C3036	4017-20284-00	CAP CHIP X7R 100NF 16V
C3037	4017-20284-00	CAP CHIP X7R 100NF 16V
C3038	4017-20271-00	CAP CHIP X7R 10NF 10%
C3040	4017-25269-00	CAP 0603 NPO 68P 50V
C3041	4017-25269-00	CAP 0603 NPO 68P 50V
C3042	4017-25274-00	CAP 0603 NPO 180P 50V
C3043	4017-25274-00	CAP 0603 NPO 180P 50V
C3044	4017-25066-00	CAP CHIP CER COG 39PF
C3045	4017-20284-00	CAP CHIP X7R 100NF 16V
C3046	4017-20284-00	CAP CHIP X7R 100NF 16V
C3047	4017-20284-00	CAP CHIP X7R 100NF 16V
C3048	4017-20284-00	CAP CHIP X7R 100NF 16V
C3075	4017-20271-00	CAP CHIP X7R 10NF 10%
C3110	4017-20284-00	CAP CHIP X7R 100NF 16V
C3111	4017-20284-00	CAP CHIP X7R 100NF 16V

Table 7-1. FTN6067A, LORD Board, Parts List

Reference Designation	Part No.	Description
C3112	4017-20284-00	CAP CHIP X7R 100NF 16V
C3500	4017-80125-02	CAP CHIP TAN 4.7UF 25V
C3900	2072-17107-00	CAP TANT CHIP 33UF 16V
C4000	4017-20276-00	CAP CHIP X7 33NF 25V
C4002	2072-17029-00	CAP CHIP X7R 680PF
C4004	2072-17110-00	CAP CHIP 0603 X7R 1UF 2
C4007	4017-25282-00	CAP CHIP CG 1NF 5%
C4008	4017-25282-00	CAP CHIP CG 1NF 5%
C4009	2072-17110-00	CAP CHIP 0603 X7R 1UF 2
C4010	2072-17110-00	CAP CHIP 0603 X7R 1UF 2
C4011	2072-17110-00	CAP CHIP 0603 X7R 1UF 2
C4012	2072-17110-00	CAP CHIP 0603 X7R 1UF 2
C4013	2072-17032-00	CAP CHIP X7R 3.3NF
C4014	2072-17029-00	CAP CHIP X7R 680PF
C4015	4017-20261-00	CAP 0603 X7R 1.5N 50V
C4016	2072-17110-00	CAP CHIP 0603 X7R 1UF 2
C4017	2072-17110-00	CAP CHIP 0603 X7R 1UF 2
C4018	4017-20284-00	CAP CHIP X7R 100NF 16V
C4020	4017-25077-00	CAP CHIP CER COG 330PF
C4021	4017-25282-00	CAP CHIP CG 1NF 5%
C4022	4017-25282-00	CAP CHIP CG 1NF 5%
C4023	2072-17029-00	CAP CHIP X7R 680PF
C4024	4017-20183-00	CAP 1812 X7R 100N 100V
C4025	4017-80125-02	CAP CHIP TAN 4.7UF 25V
C4026	4017-20183-00	CAP 1812 X7R 100N 100V
C4027	4017-80125-02	CAP CHIP TAN 4.7UF 25V
C4030	4017-20183-00	CAP 1812 X7R 100N 100V
C4035	2072-17110-00	CAP CHIP 0603 X7R 1UF 2
C4038	4017-20284-00	CAP CHIP X7R 100NF 16V
C4039	4017-20271-00	CAP CHIP X7R 10NF 10%
C4040	2072-17104-00	CAP TANT CHIP 10UF 16V
C4042	4017-20284-00	CAP CHIP X7R 100NF 16V
C4043	2072-17104-00	CAP TANT CHIP 10UF 16V
C4044	2072-17107-00	CAP TANT CHIP 33UF 16V
C4045	2072-17104-00	CAP TANT CHIP 10UF 16V
C4047	4017-25282-00	CAP CHIP CG 1NF 5%
C4051	2072-17110-00	CAP CHIP 0603 X7R 1UF 2
C4052	4017-25077-00	CAP CHIP CER COG 330PF
C4053	2072-17110-00	CAP CHIP 0603 X7R 1UF 2
C4054	4017-80125-02	CAP CHIP TAN 4.7UF 25V
C4055	2072-17110-00	CAP CHIP 0603 X7R 1UF 2
C4056	2072-17029-00	CAP CHIP X7R 680PF
C4057	4017-20271-00	CAP CHIP X7R 10NF 10%
C4058	2072-17110-00	CAP CHIP 0603 X7R 1UF 2
C4059	4017-25060-00	CAP CHIP CER COG 12PF
C4060	4017-25060-00	CAP CHIP CER COG 12PF
C4061	4017-80125-02	CAP CHIP TAN 4.7UF 25V

Table 7-1. FTN6067A, LORD Board, Parts List

Reference Designation	Part No.	Description
C4062	2072-17110-00	CAP CHIP 0603 X7R 1UF 2
C4064	4017-25282-00	CAP CHIP CG 1NF 5%
C4065	4017-25282-00	CAP CHIP CG 1NF 5%
C4066	4017-25282-00	CAP CHIP CG 1NF 5%
C4067	4017-20284-00	CAP CHIP X7R 100NF 16V
C4068	4017-25282-00	CAP CHIP CG 1NF 5%
C4069	4017-80125-02	CAP CHIP TAN 4.7UF 25V
C4070	2072-17105-00	CAP TANT CHIP 15UF 25V
C4071	2072-17110-00	CAP CHIP 0603 X7R 1UF 2
C4072	2072-17110-00	CAP CHIP 0603 X7R 1UF 2
C4073	2072-17029-00	CAP CHIP X7R 680PF
C4074	2072-17821-00	CAP CHIP X7R 390NF 16V
C4075	2072-17110-00	CAP CHIP 0603 X7R 1UF 2
C4300	4017-20271-00	CAP CHIP X7R 10NF 10%
C4400	4017-80125-02	CAP CHIP TAN 4.7UF 25V
C5000	4017-20284-00	CAP CHIP X7R 100NF 16V
C5001	4017-20284-00	CAP CHIP X7R 100NF 16V
C5002	4017-20284-00	CAP CHIP X7R 100NF 16V
C5003	4017-20284-00	CAP CHIP X7R 100NF 16V
C5004	4017-20284-00	CAP CHIP X7R 100NF 16V
C5005	4017-20284-00	CAP CHIP X7R 100NF 16V
C5006	4017-20271-00	CAP CHIP X7R 10NF 10%
C5007	2072-17107-00	CAP TANT CHIP 33UF 16V
C5008	4017-20284-00	CAP CHIP X7R 100NF 16V
C5009	4017-20284-00	CAP CHIP X7R 100NF 16V
C5010	4017-20284-00	CAP CHIP X7R 100NF 16V
C5011	4017-20284-00	CAP CHIP X7R 100NF 16V
C5012	4017-20284-00	CAP CHIP X7R 100NF 16V
C5013	4017-20284-00	CAP CHIP X7R 100NF 16V
C5016	4017-20284-00	CAP CHIP X7R 100NF 16V
C5017	4017-20284-00	CAP CHIP X7R 100NF 16V
C5021	4017-25282-00	CAP CHIP CG 1NF 5%
C5022	4017-20267-00	CAP CHIP X7R 4.7NF 10%
C5023	4017-20284-00	CAP CHIP X7R 100NF 16V
C5024	4017-20284-00	CAP CHIP X7R 100NF 16V
C5025	4017-20284-00	CAP CHIP X7R 100NF 16V
C5026	4017-20284-00	CAP CHIP X7R 100NF 16V
C5027	4017-20284-00	CAP CHIP X7R 100NF 16V
C5028	4017-20284-00	CAP CHIP X7R 100NF 16V
C5029	4017-20284-00	CAP CHIP X7R 100NF 16V
C5032	2072-17018-00	CAP CHIP 0603 20PF
C5033	2072-17018-00	CAP CHIP 0603 20PF
C6000	2072-17107-00	CAP TANT CHIP 33UF 16V
C6002	4017-20284-00	CAP CHIP X7R 100NF 16V
C6004	4017-20284-00	CAP CHIP X7R 100NF 16V
C6006	4017-20284-00	CAP CHIP X7R 100NF 16V
C6008	4017-20284-00	CAP CHIP X7R 100NF 16V

Table 7-1. FTN6067A, LORD Board, Parts List

Reference Designation	Part No.	Description
C6010	4017-20284-00	CAP CHIP X7R 100NF 16V
C6013	4017-20284-00	CAP CHIP X7R 100NF 16V
C6014	4017-25271-00	CAP CHIP CG 100PF 5%
C6015	4017-25271-00	CAP CHIP CG 100PF 5%
C6016	4017-20284-00	CAP CHIP X7R 100NF 16V
C6019	4017-20284-00	CAP CHIP X7R 100NF 16V
C6020	4017-20284-00	CAP CHIP X7R 100NF 16V
C6021	4017-20284-00	CAP CHIP X7R 100NF 16V
C6032	2072-17104-00	CAP TANT CHIP 10UF 16V
C6033	4017-20271-00	CAP CHIP X7R 10NF 10%
C6034	4017-20284-00	CAP CHIP X7R 100NF 16V
C6035	4017-20284-00	CAP CHIP X7R 100NF 16V
C6039	4017-20284-00	CAP CHIP X7R 100NF 16V
C6040	4017-25276-00	CAP CHIP CG 270PF 5%
C6041	4017-25276-00	CAP CHIP CG 270PF 5%
C7001	4017-25259-00	CAP CHIP CG 10PF 5%
C7002	4017-25259-00	CAP CHIP CG 10PF 5%
C7003	4017-20284-00	CAP CHIP X7R 100NF 16V
C7004	4017-20284-00	CAP CHIP X7R 100NF 16V
C7005	2072-17107-00	CAP TANT CHIP 33UF 16V
C7006	2072-17107-00	CAP TANT CHIP 33UF 16V
C7007	4017-25276-00	CAP CHIP CG 270PF 5%
C7008	4017-25276-00	CAP CHIP CG 270PF 5%
C7009	4017-25276-00	CAP CHIP CG 270PF 5%
C7010	4017-20271-00	CAP CHIP X7R 10NF 10%
C7011	4017-20284-00	CAP CHIP X7R 100NF 16V
C7012	4017-20284-00	CAP CHIP X7R 100NF 16V
C7013	4017-20284-00	CAP CHIP X7R 100NF 16V
C7014	4017-20284-00	CAP CHIP X7R 100NF 16V
C7015	4017-20284-00	CAP CHIP X7R 100NF 16V
C7016	4017-20284-00	CAP CHIP X7R 100NF 16V
C7017	4017-20284-00	CAP CHIP X7R 100NF 16V
C7018	4017-20284-00	CAP CHIP X7R 100NF 16V
C7019	4017-20284-00	CAP CHIP X7R 100NF 16V
C7020	4017-20271-00	CAP CHIP X7R 10NF 10%
C7021	4017-25276-00	CAP CHIP CG 270PF 5%
C7022	4017-20284-00	CAP CHIP X7R 100NF 16V
C7027	4017-20284-00	CAP CHIP X7R 100NF 16V
C7028	4017-25276-00	CAP CHIP CG 270PF 5%
C7029	4017-20284-00	CAP CHIP X7R 100NF 16V
C7030	2072-17105-00	CAP TANT CHIP 15UF 25V
C7031	4017-20284-00	CAP CHIP X7R 100NF 16V
C9000	4017-25282-00	CAP CHIP CG 1NF 5%
C9020	4017-25282-00	CAP CHIP CG 1NF 5%
C9040	4017-25282-00	CAP CHIP CG 1NF 5%
C9060	4017-25282-00	CAP CHIP CG 1NF 5%
C9061	4017-25056-00	CAP CHIP CER COG 5.6PF

Table 7-1. FTN6067A, LORD Board, Parts List

Reference Designation	Part No.	Description
C9062	4017-25061-00	CAP CHIP CER COG 15PF
C9063	2072-17053-00	CAP CHIP 5PF
C9066	4017-25061-00	CAP CHIP CER COG 15PF
C9067	4017-25060-00	CAP CHIP CER COG 12PF
C9069	4017-25060-00	CAP CHIP CER COG 12PF
C9070	4017-25060-00	CAP CHIP CER COG 12PF
C9071	4017-25060-00	CAP CHIP CER COG 12PF
C9072	4017-25269-00	CAP 0603 NPO 68P 50V
C9074	2072-17014-00	CAP CHIP 0805 43PF 5%
C9075	4017-25265-00	CAP CHIP 0603 NPO 33PF
C9076	2072-17011-00	CAP CHIP 0805 7.5PF
C9078	4017-25053-00	CAP CHIP CER COG 3.3PF
C9080	4017-25053-00	CAP CHIP CER COG 3.3PF
C9081	2072-17052-00	CAP CHIP 2.2PF
C9082	2072-17001-00	CAP CHIP 0805 30PF 5%
C9084	4017-25077-00	-CAP CHIP CER COG 330PF
C9087	4017-25282-00	CAP CHIP CG 1NF 5%
C9089	4017-25282-00	CAP CHIP CG 1NF 5%
C9091	4017-25282-00	CAP CHIP CG 1NF 5%
C9094	4017-25061-00	CAP CHIP CER COG 15PF
C9095	4017-25060-00	CAP CHIP CER COG 12PF
C9096	2072-17014-00	CAP CHIP 0805 43PF 5%
C9097	4017-25060-00	CAP CHIP CER COG 12PF
C9098	4017-25074-00	CAP CHIP CER COG 180PF
C9099	4017-25282-00	CAP CHIP CG 1NF 5%
C9110	4017-25274-00	CAP 0603 NPO 180P 50V
C9200	4017-25282-00	CAP CHIP CG 1NF 5%
C9300	4017-25274-00	CAP 0603 NPO 180P 50V
C9400	4017-25282-00	CAP CHIP CG 1NF 5%
C9401	4017-20271-00	CAP CHIP X7R 10NF 10%
C9407	2072-17821-00	CAP CHIP X7R 390NF 16V
C9419	2072-17104-00	CAP TANT CHIP 10UF 16V
C9420	2072-17104-00	CAP TANT CHIP 10UF 16V
C9421	2072-17104-00	CAP TANT CHIP 10UF 16V
C9422	2072-17104-00	CAP TANT CHIP 10UF 16V
C9423	2072-17104-00	CAP TANT CHIP 10UF 16V
C9472	2072-17105-00	CAP TANT CHIP 15UF 25V
C9481	4017-20271-00	CAP CHIP X7R 10NF 10%
C9482	4017-20271-00	CAP CHIP X7R 10NF 10%
C9483	4017-20271-00	CAP CHIP X7R 10NF 10%
C9484	4017-20271-00	CAP CHIP X7R 10NF 10%
C9485	4017-20271-00	CAP CHIP X7R 10NF 10%
C9486	4017-20271-00	CAP CHIP X7R 10NF 10%
C9487	4017-20271-00	CAP CHIP X7R 10NF 10%
C9488	4017-20271-00	CAP CHIP X7R 10NF 10%
C9489	4017-20271-00	CAP CHIP X7R 10NF 10%
C9490	4017-20271-00	CAP CHIP X7R 10NF 10%

Table 7-1. FTN6067A, LORD Board, Parts List

Reference Designation	Part No.	Description
C9491	4017-20284-00	CAP CHIP X7R 100NF 16V
C9492	4017-20284-00	CAP CHIP X7R 100NF 16V
C9496	4017-20271-00	CAP CHIP X7R 10NF 10%
C9498	4017-20284-00	CAP CHIP X7R 100NF 16V
C9499	4017-20284-00	CAP CHIP X7R 100NF 16V
C9500	4017-20284-00	CAP CHIP X7R 100NF 16V
C9501	4017-20284-00	CAP CHIP X7R 100NF 16V
C9502	4017-20284-00	CAP CHIP X7R 100NF 16V
C9503	4017-20284-00	CAP CHIP X7R 100NF 16V
C9506	4017-20284-00	CAP CHIP X7R 100NF 16V
C9507	4017-20284-00	CAP CHIP X7R 100NF 16V
C9508	4017-20284-00	CAP CHIP X7R 100NF 16V
C9509	4017-20284-00	CAP CHIP X7R 100NF 16V
C9511	4017-20284-00	CAP CHIP X7R 100NF 16V
C9515	4017-20284-00	CAP CHIP X7R 100NF 16V
C9518	4017-20284-00	CAP CHIP X7R 100NF 16V
C9519	4017-20284-00	CAP CHIP X7R 100NF 16V
C9520	2072-17110-00	CAP CHIP 0603 X7R 1UF 2
C9521	2072-17110-00	CAP CHIP 0603 X7R 1UF 2
C9522	2072-17110-00	CAP CHIP 0603 X7R 1UF 2
C9523	4017-20284-00	CAP CHIP X7R 100NF 16V
C9524	4017-20284-00	CAP CHIP X7R 100NF 16V
C9525	2072-17110-00	CAP CHIP 0603 X7R 1UF 2
C9526	2072-17110-00	CAP CHIP 0603 X7R 1UF 2
C9527	2072-17110-00	CAP CHIP 0603 X7R 1UF 2
C9530	4017-20284-00	CAP CHIP X7R 100NF 16V
C9531	2072-17110-00	CAP CHIP 0603 X7R 1UF 2
C9532	4017-25276-00	CAP CHIP CG 270PF 5%
C9533	4017-25276-00	CAP CHIP CG 270PF 5%
C9534	4017-25276-00	CAP CHIP CG 270PF 5%
C9535	4017-25276-00	CAP CHIP CG 270PF 5%
C9536	4017-20284-00	CAP CHIP X7R 100NF 16V
C9537	4017-20284-00	CAP CHIP X7R 100NF 16V
C9538	4017-25271-00	CAP CHIP CG 100PF 5%
C9539	4017-25271-00	CAP CHIP CG 100PF 5%
C9540	4017-25271-00	CAP CHIP CG 100PF 5%
C9541	4017-25271-00	CAP CHIP CG 100PF 5%
C9542	2072-17110-00	CAP CHIP 0603 X7R 1UF 2
C9543	2072-17029-00	CAP CHIP X7R 680PF
C9544	2072-17029-00	CAP CHIP X7R 680PF
C9545	4017-25077-00	CAP CHIP CER COG 330PF
C9546	4017-25276-00	CAP CHIP CG 270PF 5%
C9547	4017-25276-00	CAP CHIP CG 270PF 5%
C9548	4017-20284-00	CAP CHIP X7R 100NF 16V
C9549	4017-20284-00	CAP CHIP X7R 100NF 16V
C9551	2072-17107-00	CAP TANT CHIP 33UF 16V
C9552	2072-17107-00	CAP TANT CHIP 33UF 16V

Table 7-1. FTN6067A, LORD Board, Parts List

Reference Designation	Part No.	Description
C9553	4017-80125-02	CAP CHIP TAN 4.7UF 25V
C9554	4017-80125-02	CAP CHIP TAN 4.7UF 25V
C9555	4017-80125-02	CAP CHIP TAN 4.7UF 25V
C9556	4017-20284-00	CAP CHIP X7R 100NF 16V
C9557	4017-20284-00	CAP CHIP X7R 100NF 16V
C9558	4017-20284-00	CAP CHIP X7R 100NF 16V
C9559	4017-20284-00	CAP CHIP X7R 100NF 16V
C9560	4017-20284-00	CAP CHIP X7R 100NF 16V
C9561	4017-20284-00	CAP CHIP X7R 100NF 16V
CR1	2072-21025-00	PIN DIODE 35V
CR2	2072-21025-00	PIN DIODE 35V
CR3	2072-21025-00	PIN DIODE 35V
CR4	2072-21025-00	PIN DIODE 35V
CR5	2072-21025-00	PIN DIODE 35V
CR6	2072-21025-00	PIN DIODE 35V
CR7	2072-21025-00	PIN DIODE 35V
CR8	2072-21025-00	PIN DIODE 35V
CR9	2072-21025-00	PIN DIODE 35V
CR10	2072-21025-00	PIN DIODE 35V
CR11	2072-21025-00	PIN DIODE 35V
CR12	2072-21025-00	PIN DIODE 35V
CR13	2072-21025-00	PIN DIODE 35V
CR14	2072-21025-00	PIN DIODE 35V
CR15	2072-21025-00	PIN DIODE 35V
CR16	2072-21025-00	PIN DIODE 35V
CR17	2072-21025-00	PIN DIODE 35V
CR1000	2072-21025-00	PIN DIODE 35V
CR1001	4021-10114-35	SKY DIODE 50V HSMS2800
CR1002	4021-10721-35	DIODE GEN PURP .1A 100V
CR1003	4021-10721-35	DIODE GEN PURP .1A 100V
CR1004	4021-10721-35	DIODE GEN PURP .1A 100V
CR1005	4021-10721-35	DIODE GEN PURP .1A 100V
CR1006	4021-10721-35	DIODE GEN PURP .1A 100V
CR1007	4021-10721-35	DIODE GEN PURP .1A 100V
CR1008	2072-21025-00	PIN DIODE 35V
CR1009	2072-21025-00	PIN DIODE 35V
CR1010	2072-21025-00	PIN DIODE 35V
CR1011	2072-21025-00	PIN DIODE 35V
CR1012	2072-21025-00	PIN DIODE 35V
CR1903	4021-10721-35	DIODE GEN PURP .1A 100V
CR1904	2072-21025-00	PIN DIODE 35V
CR1905	2072-21025-00	PIN DIODE 35V
CR2000	2072-21014-00	DIODE TRIPLE SOT143-RH
CR2001	2072-21025-00	PIN DIODE 35V
CR2002	2072-21025-00	PIN DIODE 35V
CR2003	2072-21025-00	PIN DIODE 35V
CR2008	4021-10721-35	DIODE GEN PURP .1A 100V

Table 7-1. FTN6067A, LORD Board, Parts List

Reference Designation	Part No.	Description
CR2009	4021-10721-35	DIODE GEN PURP .1A 100V
CR5000	4021-10115-35	SKY DIODE 70V SOT-23
CR5001	4021-10721-35	DIODE GEN PURP .1A 100V
CR5002	4021-10115-35	SKY DIODE 70V SOT-23
CR5003	4021-10115-35	SKY DIODE 70V SOT-23
CR5004	4021-10115-35	SKY DIODE 70V SOT-23
CR5005	4021-10115-35	SKY DIODE 70V SOT-23
CR9000	2072-21124-00	VARICAP 39PF
CR9020	2072-21124-00	VARICAP 39PF
CR9040	2072-21124-00	VARICAP 39PF
CR9063	4021-10115-35	SKY DIODE 70V SOT-23
CR9064	4021-10115-35	SKY DIODE 70V SOT-23
CR9066	2072-21124-00	VARICAP 39PF
CR9067	2072-21124-00	VARICAP 39PF
CR9068	4021-10115-35	SKY DIODE 70V SOT-23
CR9069	2072-21124-00	VARICAP 39PF
CR9070	4021-10721-35	DIODE GEN PURP .1A 100V
CR9071	2072-21124-00	VARICAP 39PF
CR9073	2072-21124-00	VARICAP 39PF
CR9074	2072-21124-00	VARICAP 39PF
CR9075	2072-21124-00	VARICAP 39PF
CR9076	2072-21124-00	VARICAP 39PF
CR9077	4021-10721-35	DIODE GEN PURP .1A 100V
CR9078	2072-21029-00	DIODE VARACTOR
E1001	2072-18001-00	INDUCTOR BEAD CHIP
E1002	2072-18001-00	INDUCTOR BEAD CHIP
F1	4023-60003-00	MULTIFUSE CHIP 500MA
FL1	2072-14001-00	XTAL FLTR 45.1MHZ 25KHZ
FL2	2072-14001-00	XTAL FLTR 45.1MHZ 25KHZ
FL3	2072-14002-00	XTAL FLTR 45.1MHZ 25KHZ
FL4	2072-14002-00	XTAL FLTR 45.1MHZ 25KHZ
J1	2072-33016-00	RECEPTACLE COAX 002 PIN
J2	2072-33016-00	RECEPTACLE COAX 002 PIN
J3	2072-33007-00	HEADER RT 40 PIN
J4	4033-51109-01	CONN. 2P 1.25mm SMT PLU
J5	2072-33008-00	CONNECTOR D-TYPE 44 PIN
J6	2072-33006-00	CONN HEADER 24 PIN RIGH
J7	2072-33003-00	PLUG SMD LOPRO 25 POS
L1	4018-12329-00	INDUCTOR, CHIP 910NH 5
L2	4018-12329-00	INDUCTOR, CHIP 910NH 5
L3	2072-18009-00	IND CHIP 680NH 5%
L4	4018-12206-00	CHIP IND 22UH 5% 1008
L5	4018-12206-00	CHIP IND 22UH 5% 1008
L6	4018-12206-00	CHIP IND 22UH 5% 1008
L7	4018-12206-00	CHIP IND 22UH 5% 1008
L8	4018-12206-00	CHIP IND 22UH 5% 1008
L9	2072-18008-00	CHIP IND 10000NH 5%

Table 7-1. FTN6067A, LORD Board, Parts List

Reference Designation	Part No.	Description
L10	2072-18008-00	CHIP IND 10000NH 5%
L12	2072-18008-00	CHIP IND 10000NH 5%
L13	2072-18008-00	CHIP IND 10000NH 5%
L14	2072-18008-00	CHIP IND 10000NH 5%
L15	2072-18008-00	CHIP IND 10000NH 5%
L16	4018-12036-50	RFC 3.3UH 5%
L20	4018-12032-20	RFC 1.5UH 2% SMT
L22	4018-12022-20	RFC 390NH 2% SMT
L25	2072-18006-00	CHIP IND 8200NH 5%
L26	2072-18006-00	CHIP IND 8200NH 5%
L27	2072-18005-00	CHIP IND 6800NH 5%
L28	2072-18005-00	CHIP IND 6800NH 5%
L29	2072-18005-00	CHIP IND 6800NH 5%
L30	2072-18005-00	CHIP IND 6800NH 5%
L31	2072-18005-00	CHIP IND 6800NH 5%
L32	2072-18005-00	CHIP IND 6800NH 5%
L33	2072-18005-00	CHIP IND 6800NH 5%
L34	2072-18005-00	CHIP IND 6800NH 5%
L35	2072-18005-00	CHIP IND 6800NH 5%
L36	2072-18005-00	CHIP IND 6800NH 5%
L37	2072-18004-00	CHIP IND 5600NH 5%
L38	2072-18004-00	CHIP IND 5600NH 5%
L39	2072-18003-00	CHIP IND 4700NH 5% 246
L42	2072-18002-00	CHIP IND 1200NH 5%
L43	2072-18002-00	CHIP IND 1200NH 5%
L44	4018-12320-10	RFC 0.27 UH 1% SMT
L45	4018-12320-10	RFC 0.27 UH 1% SMT
L46	4018-12206-00	CHIP IND 22UH 5% 1008
L47	2072-18010-00	CHIP IND 2200NH 10%
L48	2072-18010-00	CHIP IND 2200NH 10%
L49	2072-18010-00	CHIP IND 2200NH 10%
L50	4018-12329-00	INDUCTOR, CHIP 910NH 5
L51	4018-12206-00	CHIP IND 22UH 5% 1008
L52	4018-12206-00	CHIP IND 22UH 5% 1008
L53	4018-12036-50	RFC 3.3UH 5%
L54	4018-12036-50	RFC 3.3UH 5%
L55	4018-12206-00	CHIP IND 22UH 5% 1008
L1000	4018-12206-00	CHIP IND 22UH 5% 1008
L1006	4018-12320-10	RFC 0.27 UH 1% SMT
L1007	4018-12320-10	RFC 0.27 UH 1% SMT
L1008	4018-12320-10	RFC 0.27 UH 1% SMT
L1012	4018-12329-00	INDUCTOR, CHIP 910NH 5
L1013	4018-12320-10	RFC 0.27 UH 1% SMT
L1014	4018-12320-10	RFC 0.27 UH 1% SMT
L1015	4018-12320-10	RFC 0.27 UH 1% SMT
L1016	4018-12320-10	RFC 0.27 UH 1% SMT
L1017	4018-12206-00	CHIP IND 22UH 5% 1008

Table 7-1. FTN6067A, LORD Board, Parts List

Reference Designation	Part No.	Description
L1018	4018-12206-00	CHIP IND 22UH 5% 1008
L1020	4018-12206-00	CHIP IND 22UH 5% 1008
L1021	4018-12206-00	CHIP IND 22UH 5% 1008
L1022	4018-12206-00	CHIP IND 22UH 5% 1008
L1023	4018-12206-00	CHIP IND 22UH 5% 1008
L1024	4018-12206-00	CHIP IND 22UH 5% 1008
L1025	4018-12206-00	CHIP IND 22UH 5% 1008
L1027	4018-12206-00	CHIP IND 22UH 5% 1008
L1028	4018-12206-00	CHIP IND 22UH 5% 1008
L1029	4018-12206-00	CHIP IND 22UH 5% 1008
L1030	4018-12206-00	CHIP IND 22UH 5% 1008
L1033	4018-12206-00	CHIP IND 22UH 5% 1008
L1034	4018-12206-00	CHIP IND 22UH 5% 1008
L1041	2072-18008-00	CHIP IND 10000NH 5%
L1042	2072-18008-00	CHIP IND 10000NH 5%
L1043	2072-18008-00	CHIP IND 10000NH 5%
L1044	2072-18008-00	CHIP IND 10000NH 5%
L1045	4018-12024-50	RFC 0.560UH 5%
L1046	4018-12026-20	RFC 680NH 2% SMT
L1047	4018-12026-20	RFC 680NH 2% SMT
L1048	4018-12026-20	RFC 680NH 2% SMT
L1049	4018-12026-20	RFC 680NH 2% SMT
L1050	4018-12014-00	COIL CHIP 82NH 5%
L1052	2072-18008-00	CHIP IND 10000NH 5%
L1054	2072-18008-00	CHIP IND 10000NH 5%
L1056	4018-12320-10	RFC 0.27 UH 1% SMT
L1057	4018-12320-10	RFC 0.27 UH 1% SMT
L1059	4018-12206-00	CHIP IND 22UH 5% 1008
L1214	4018-12206-00	CHIP IND 22UH 5% 1008
L1800	4018-12206-00	CHIP IND 22UH 5% 1008
L1801	4018-12029-20	RFC 1UH 2% SMT
L1802	4018-12029-20	RFC 1UH 2% SMT
L1803	4018-12029-20	RFC 1UH 2% SMT
L1804	4018-12029-20	RFC 1UH 2% SMT
L1805	4018-12206-00	CHIP IND 22UH 5% 1008
L1806	4018-12206-00	CHIP IND 22UH 5% 1008
L1807	2072-18009-00	IND CHIP 680NH 5%
L1FL1	4018-12206-00	CHIP IND 22UH 5% 1008
L1FL2	4018-12206-00	CHIP IND 22UH 5% 1008
L1FL3	4018-12206-00	CHIP IND 22UH 5% 1008
L1FL4	4018-12206-00	CHIP IND 22UH 5% 1008
L1FL5	4018-12206-00	CHIP IND 22UH 5% 1008
L1FL6	4018-12206-00	CHIP IND 22UH 5% 1008
L1FL7	4018-12206-00	CHIP IND 22UH 5% 1008
L1FL8	4018-12206-00	CHIP IND 22UH 5% 1008
L1FL9	4018-12206-00	CHIP IND 22UH 5% 1008
L1FL10	4018-12206-00	CHIP IND 22UH 5% 1008

Table 7-1. FTN6067A, LORD Board, Parts List

Reference Designation	Part No.	Description
L1FL11	4018-12206-00	CHIP IND 22UH 5% 1008
L1FL12	4018-12206-00	CHIP IND 22UH 5% 1008
L1FL13	4018-12206-00	CHIP IND 22UH 5% 1008
L1FL14	4018-12206-00	CHIP IND 22UH 5% 1008
L1FL15	4018-12206-00	CHIP IND 22UH 5% 1008
L1FL17	4018-12206-00	CHIP IND 22UH 5% 1008
L1FL18	4018-12206-00	CHIP IND 22UH 5% 1008
L1FL19	4018-12206-00	CHIP IND 22UH 5% 1008
L1FL20	4018-12206-00	CHIP IND 22UH 5% 1008
L1FL21	4018-12206-00	CHIP IND 22UH 5% 1008
L1FL23	4018-12206-00	CHIP IND 22UH 5% 1008
L1FL24	4018-12206-00	CHIP IND 22UH 5% 1008
L1FL27	4018-12206-00	CHIP IND 22UH 5% 1008
L1FL28	4018-12206-00	CHIP IND 22UH 5% 1008
L1FL29	4018-12206-00	CHIP IND 22UH 5% 1008
L1FL30	4018-12206-00	CHIP IND 22UH 5% 1008
L1FL31	4018-12206-00	CHIP IND 22UH 5% 1008
L1FL32	4018-12206-00	CHIP IND 22UH 5% 1008
L1FL33	4018-12206-00	CHIP IND 22UH 5% 1008
L2000	4018-12419-00	RFC CHIP 33NH 5%
L2001	2072-18002-00	CHIP IND 1200NH 5%
L2002	4018-12320-10	RFC 0.27 UH 1% SMT
L2003	4018-12320-10	RFC 0.27 UH 1% SMT
L2004	4018-12320-10	RFC 0.27 UH 1% SMT
L2005	2072-18007-00	CHIP IND 8.2NH 5%
L2006	4018-12015-20	RFC 100NH 2% SMT
L2007	4018-12015-20	RFC 100NH 2% SMT
L2008	4018-12015-20	RFC 100NH 2% SMT
L2009	4018-12015-20	RFC 100NH 2% SMT
L2011	4018-12006-00	COIL CHIP 15NH 5%
L2012	4018-12013-00	RFC 68NH 10% SMT
L2013	4018-12013-00	RFC 68NH 10% SMT
L2017	2072-18008-00	CHIP IND 10000NH 5%
L2018	2072-18008-00	CHIP IND 10000NH 5%
L2019	2072-18008-00	CHIP IND 10000NH 5%
L2020	2072-18008-00	CHIP IND 10000NH 5%
L2021	2072-18008-00	CHIP IND 10000NH 5%
L2022	2072-18008-00	CHIP IND 10000NH 5%
L2023	4018-12016-20	RFC 120NH 2% SMT
L2024	4018-12029-20	RFC 1UH 2% SMT
L2025	4018-12029-20	RFC 1UH 2% SMT
L2026	4018-12014-00	COIL CHIP 82NH 5%
L2027	4018-12016-20	RFC 120NH 2% SMT
L2028	4018-12016-20	RFC 120NH 2% SMT
L3000	4018-12032-20	RFC 1.5UH 2% SMT
L3001	2072-18008-00	CHIP IND 10000NH 5%
L3002	2072-18008-00	CHIP IND 10000NH 5%

Table 7-1. FTN6067A, LORD Board, Parts List

Reference Designation	Part No.	Description
L3003	2072-18008-00	CHIP IND 10000NH 5%
L3004	2072-18008-00	CHIP IND 10000NH 5%
L3005	2072-18008-00	CHIP IND 10000NH 5%
L3006	2072-18008-00	CHIP IND 10000NH 5%
L3007	4018-12032-20	RFC 1.5UH 2% SMT
L3008	4018-12032-20	RFC 1.5UH 2% SMT
L4001	4018-12206-00	CHIP IND 22UH 5% 1008
L4002	4018-12206-00	CHIP IND 22UH 5% 1008
L5000	4018-12206-00	CHIP IND 22UH 5% 1008
L5001	4018-12206-00	CHIP IND 22UH 5% 1008
L5002	4018-12206-00	CHIP IND 22UH 5% 1008
L6000	2072-18009-00	IND CHIP 680NH 5%
L9000	4018-12032-20	RFC 1.5UH 2% SMT
L9020	4018-12032-20	RFC 1.5UH 2% SMT
L9040	4018-12032-20	RFC 1.5UH 2% SMT
L9060	4018-12329-00	INDUCTOR, CHIP 910NH 5
L9061	4018-12329-00	INDUCTOR, CHIP 910NH 5
L9062	4018-12329-00	INDUCTOR, CHIP 910NH 5
L9064A	4018-20024-00	COIL VAR. 28NH
L9065A	4018-20004-00	COIL VAR. 53NH
L9066A	4018-20004-00	COIL VAR. 53NH
L9070	4018-12032-20	RFC 1.5UH 2% SMT
L9072	4018-12032-20	RFC 1.5UH 2% SMT
L9073	4018-12032-20	RFC 1.5UH 2% SMT
L9074	4018-12032-20	RFC 1.5UH 2% SMT
L9076A	4018-20006-00	COIL VAR. 67NH
L9077	4018-12032-20	RFC 1.5UH 2% SMT
L9079	4018-12032-20	RFC 1.5UH 2% SMT
L9080	4018-12206-00	CHIP IND 22UH 5% 1008
Q1	4021-00342-35	NPN 40V .2A GEN PURP
Q2	4021-00342-35	NPN 40V .2A GEN PURP
Q3	4021-00342-35	NPN 40V .2A GEN PURP
Q4	4021-00342-35	NPN 40V .2A GEN PURP
Q5	4021-00342-35	NPN 40V .2A GEN PURP
Q6	4021-00342-35	NPN 40V .2A GEN PURP
Q7	4021-00342-35	NPN 40V .2A GEN PURP
Q8	4021-00342-35	NPN 40V .2A GEN PURP
Q9	4021-00342-35	NPN 40V .2A GEN PURP
Q30	4021-00343-35	PNP 40V .2A
Q1000	4021-00342-35	NPN 40V .2A GEN PURP
Q1001	2072-21024-00	N-CH TMOS FET
Q1002	2072-21024-00	N-CH TMOS FET
Q1003	2072-21026-00	XSTR, RF SOT-23
Q1004	2072-21026-00	XSTR, RF SOT-23
Q1005	2072-21026-00	XSTR, RF SOT-23
Q1006	2072-21026-00	XSTR, RF SOT-23
Q1007	4021-00343-35	PNP 40V .2A

Table 7-1. FTN6067A, LORD Board, Parts List

Reference Designation	Part No.	Description
Q1008	4021-00343-35	PNP 40V .2A
Q1009	4021-00343-35	PNP 40V .2A
Q1010	4021-00343-35	PNP 40V .2A
Q1011	4021-00343-35	PNP 40V .2A
Q1012	4021-00343-35	PNP 40V .2A
Q1013	4021-00342-35	NPN 40V .2A GEN PURP
Q1014	4021-00342-35	NPN 40V .2A GEN PURP
Q1015	4021-00342-35	NPN 40V .2A GEN PURP
Q1017	4021-00342-35	NPN 40V .2A GEN PURP
Q1018	4021-00342-35	NPN 40V .2A GEN PURP
Q1019	4021-00342-35	NPN 40V .2A GEN PURP
Q1020	4021-00176-35	N-CH MOSFET LOW PWR
Q1021	4021-00342-35	NPN 40V .2A GEN PURP
Q1022	4021-00342-35	NPN 40V .2A GEN PURP
Q1023	4021-00342-35	NPN 40V .2A GEN PURP
Q1925	4021-00176-35	N-CH MOSFET LOW PWR
Q2006	2072-21026-00	XSTR, RF SOT-23
Q2007	2072-21026-00	XSTR, RF SOT-23
Q2901	4021-00343-35	PNP 40V .2A
Q3000	4021-00342-35	NPN 40V .2A GEN PURP
Q3001	2072-21026-00	XSTR, RF SOT-23
Q3002	2072-21026-00	XSTR, RF SOT-23
Q4000	4021-00342-35	NPN 40V .2A GEN PURP
Q4001	4021-00342-35	NPN 40V .2A GEN PURP
Q4002	4021-00342-35	NPN 40V .2A GEN PURP
Q4003	4021-00342-35	NPN 40V .2A GEN PURP
Q4004	4021-00342-35	NPN 40V .2A GEN PURP
Q4005	4021-00342-35	NPN 40V .2A GEN PURP
Q5003	4021-00176-35	N-CH MOSFET LOW PWR
Q5004	4021-00342-35	NPN 40V .2A GEN PURP
Q5005	4021-00343-35	PNP 40V .2A
Q5006	4021-00176-35	N-CH MOSFET LOW PWR
Q9000	2072-21019-00	TSTR FET
Q9020	2072-21019-00	TSTR FET
Q9040	2072-21019-00	TSTR FET
Q9060	2072-21019-00	TSTR FET
Q9063	2072-21015-00	XSTR W/RES BIAS
Q9064	2072-21015-00	XSTR W/RES BIAS
Q9065	2072-21015-00	XSTR W/RES BIAS
Q9066	4021-00342-35	NPN 40V .2A GEN PURP
Q9067	4021-00342-35	NPN 40V .2A GEN PURP
Q9068	4021-00176-35	N-CH MOSFET LOW PWR
R1	4016-41000-10	RES 2512 100 1% 1W
R2	4016-41000-10	RES 2512 100 1% 1W
R3	4016-41000-10	RES 2512 100 1% 1W
R4	4016-41000-10	RES 2512 100 1% 1W
R5	4016-21003-10	RES SMD 100K 1% 1/16W

Table 7-1. FTN6067A, LORD Board, Parts List

Reference Designation	Part No.	Description
R6	4016-21003-10	RES SMD 100K 1% 1/16W
R7	4016-21003-10	RES SMD 100K 1% 1/16W
R8	4016-21003-10	RES SMD 100K 1% 1/16W
R9	4016-21003-10	RES SMD 100K 1% 1/16W
R10	4016-21003-10	RES SMD 100K 1% 1/16W
R11	4016-21003-10	RES SMD 100K 1% 1/16W
R12	4016-21003-10	RES SMD 100K 1% 1/16W
R13	4016-26811-10	RES CHIP 0603 6.81K 1%
R14	4016-26811-10	RES CHIP 0603 6.81K 1%
R15	4016-26811-10	RES CHIP 0603 6.81K 1%
R16	4016-26811-10	RES CHIP 0603 6.81K 1%
R17	4016-26811-10	RES CHIP 0603 6.81K 1%
R18	4016-26811-10	RES CHIP 0603 6.81K 1%
R19	4016-26811-10	RES CHIP 0603 6.81K 1%
R20	4016-26811-10	RES CHIP 0603 6.81K 1%
R21	4016-26811-10	RES CHIP 0603 6.81K 1%
R22	4016-26811-10	RES CHIP 0603 6.81K 1%
R23	4016-21211-10	RES SMD 1.21K 1% 1/16W
R24	4016-21211-10	RES SMD 1.21K 1% 1/16W
R25	4016-21211-10	RES SMD 1.21K 1% 1/16W
R26	4016-21211-10	RES SMD 1.21K 1% 1/16W
R27	4016-21211-10	RES SMD 1.21K 1% 1/16W
R28	4016-21211-10	RES SMD 1.21K 1% 1/16W
R29	4016-21211-10	RES SMD 1.21K 1% 1/16W
R30	4016-21211-10	RES SMD 1.21K 1% 1/16W
R31	4016-21211-10	RES SMD 1.21K 1% 1/16W
R32	4016-20100-50	RES CHIP 10 5% 1/16W
R33	4016-22210-10	RES SMD 221 1% 1/16W
R34	4016-24750-10	RES SMD 475 1% 1/16W
R35	4016-26811-10	RES CHIP 0603 6.81K 1%
R36	4016-26811-10	RES CHIP 0603 6.81K 1%
R37	4016-21211-10	RES SMD 1.21K 1% 1/16W
R50	4016-23011-10	RES SMD 3.01K 1% 1/16W
R60	4016-21829-10	RES CHIP 0603 18.2 1%
R80	4016-25620-10	RES CHIP 0603 562 1%
R81	4016-25620-10	RES CHIP 0603 562 1%
R82	4016-20100-50	RES CHIP 10 5% 1/16W
R1000	4016-21002-10	RES SMD 10.0K 1% 1/16W
R1001	4016-21829-10	RES CHIP 0603 18.2 1%
R1002	4016-21002-10	RES SMD 10.0K 1% 1/16W
R1003	4016-21829-10	RES CHIP 0603 18.2 1%
R1005	4016-21009-10	RES CHIP 0603 10 1%
R1006	4016-26819-10	RES CHIP 0603 68.1 1%
R1007	4016-21009-10	RES CHIP 0603 10 1%
R1008	4016-21009-10	RES CHIP 0603 10 1%
R1009	4016-22001-10	RES SMD 2.0K 1% 1/16W
R1010	4016-21009-10	RES CHIP 0603 10 1%

Table 7-1. FTN6067A, LORD Board, Parts List

Reference Designation	Part No.	Description
R1011	4016-22001-10	RES SMD 2.0K 1% 1/16W
R1012	4016-22001-10	RES SMD 2.0K 1% 1/16W
R1013	4016-24750-10	RES SMD 475 1% 1/16W
R1014	4016-21009-10	RES CHIP 0603 10 1%
R1015	4016-21009-10	RES CHIP 0603 10 1%
R1016	4016-21000-10	RES SMD 100 1% 1/16W
R1017	4016-21000-10	RES SMD 100 1% 1/16W
R1018	4016-22741-10	RES SMD 2.74K 1% 1/16W
R1019	4016-22001-10	RES SMD 2.0K 1% 1/16W
R1020	4016-22001-10	RES SMD 2.0K 1% 1/16W
R1021	4016-21009-10	RES CHIP 0603 10 1%
R1022	4016-21009-10	RES CHIP 0603 10 1%
R1023	4016-21829-10	RES CHIP 0603 18.2 1%
R1024	4016-23320-10	RES SMD 332 1% 1/16W
R1025	4016-21829-10	RES CHIP 0603 18.2 1%
R1026	4016-20100-50	RES CHIP 10 5% 1/16W
R1027	4016-23320-10	RES SMD 332 1% 1/16W
R1028	4016-23320-10	RES SMD 332 1% 1/16W
R1029	4016-22740-10	RES SMD 274 1% 1/16W
R1030	4016-25119-10	RES CHIP 0603 51.1 1%
R1031	4016-20100-50	RES CHIP 10 5% 1/16W
R1032	4016-22219-10	RES SMD 22.1 1% 1/16W
R1033	4016-26819-10	RES CHIP 0603 68.1 1%
R1034	4016-21829-10	RES CHIP 0603 18.2 1%
R1035	4016-26819-10	RES CHIP 0603 68.1 1%
R1036	4016-22741-10	RES SMD 2.74K 1% 1/16W
R1037	4016-25119-10	RES CHIP 0603 51.1 1%
R1038	4016-21002-10	RES SMD 10.0K 1% 1/16W
R1039	4016-22219-10	RES SMD 22.1 1% 1/16W
R1040	4016-20100-50	RES CHIP 10 5% 1/16W
R1041	4016-20100-50	RES CHIP 10 5% 1/16W
R1042	4016-21002-10	RES SMD 10.0K 1% 1/16W
R1043	4016-22740-10	RES SMD 274 1% 1/16W
R1044	4016-22740-10	RES SMD 274 1% 1/16W
R1045	4016-23920-10	RES SMD 392 1% 1/16W
R1046	4016-22741-10	RES SMD 2.74K 1% 1/16W
R1047	4016-25119-10	RES CHIP 0603 51.1 1%
R1048	4016-21500-10	RES SMD 150 1% 1/16W
R1049	4016-25620-10	RES CHIP 0603 562 1%
R1050	4016-25620-10	RES CHIP 0603 562 1%
R1051	4016-22740-10	RES SMD 274 1% 1/16W
R1052	4016-22740-10	RES SMD 274 1% 1/16W
R1053	4016-23920-10	RES SMD 392 1% 1/16W
R1054	4016-22741-10	RES SMD 2.74K 1% 1/16W
R1055	4016-20100-50	RES CHIP 10 5% 1/16W
R1056	4016-20100-50	RES CHIP 10 5% 1/16W
R1057	4016-21500-10	RES SMD 150 1% 1/16W

Table 7-1. FTN6067A, LORD Board, Parts List

Reference Designation	Part No.	Description
R1058	4016-23320-10	RES SMD 332 1% 1/16W
R1059	4016-25119-10	RES CHIP 0603 51.1 1%
R1060	4016-24750-10	RES SMD 475 1% 1/16W
R1061	4016-24750-10	RES SMD 475 1% 1/16W
R1062	4016-22740-10	RES SMD 274 1% 1/16W
R1063	4016-22740-10	RES SMD 274 1% 1/16W
R1064	4016-23920-10	RES SMD 392 1% 1/16W
R1065	4016-21500-10	RES SMD 150 1% 1/16W
R1066	4016-20000-50	RES CHIP 0603 JUMPER
R1067	4016-20000-50	RES CHIP 0603 JUMPER
R1068	4016-32740-10	RES CHIP 0805 274 1%
R1069	4016-32740-10	RES CHIP 0805 274 1%
R1070	4016-32740-10	RES CHIP 0805 274 1%
R1071	4016-32740-10	RES CHIP 0805 274 1%
R1072	4016-21002-10	RES SMD 10.0K 1% 1/16W
R1073	4016-23011-10	RES SMD 3.01K 1% 1/16W
R1074	4016-22741-10	RES SMD 2.74K 1% 1/16W
R1075	4016-32740-10	RES CHIP 0805 274 1%
R1076	4016-32740-10	RES CHIP 0805 274 1%
R1077	4016-25119-10	RES CHIP 0603 51.1 1%
R1088	4016-25119-10	RES CHIP 0603 51.1 1%
R1200	4016-20000-50	RES CHIP 0603 JUMPER
R1201	4016-21001-10	RES SMD 1.00K 1% 1/16W
R1202	4016-24750-10	RES SMD 475 1% 1/16W
R1203	4016-24750-10	RES SMD 475 1% 1/16W
R1204	4016-24750-10	RES SMD 475 1% 1/16W
R1205	4016-24750-10	RES SMD 475 1% 1/16W
R1206	4016-20000-50	RES CHIP 0603 JUMPER
R1207	4016-20000-50	RES CHIP 0603 JUMPER
R1208	4016-21001-10	RES SMD 1.00K 1% 1/16W
R1209	4016-24750-10	RES SMD 475 1% 1/16W
R1210	4016-24750-10	RES SMD 475 1% 1/16W
R1211	4016-24750-10	RES SMD 475 1% 1/16W
R1212	4016-24750-10	RES SMD 475 1% 1/16W
R1213	4016-21001-10	RES SMD 1.00K 1% 1/16W
R1214	4016-24751-10	RES SMD 4.75K 1% 1/16W
R1215	4016-25119-10	RES CHIP 0603 51.1 1%
R1216	4016-22749-10	RES SMD 27.4 1% 1/16W
R1217	4016-23010-10	RES CHIP 0603 301 1%
R1218	4016-23010-10	RES CHIP 0603 301 1%
R1219	4016-22749-10	RES SMD 27.4 1% 1/16W
R1220	4016-23010-10	RES CHIP 0603 301 1%
R1221	4016-23010-10	RES CHIP 0603 301 1%
R1222	4016-21000-10	RES SMD 100 1% 1/16W
R1223	4016-21000-10	RES SMD 100 1% 1/16W
R1224	4016-21002-10	RES SMD 10.0K 1% 1/16W
R1225	4016-21002-10	RES SMD 10.0K 1% 1/16W

Table 7-1. FTN6067A, LORD Board, Parts List

Reference Designation	Part No.	Description
R1226	4016-21000-10	RES SMD 100 1% 1/16W
R1227	4016-21000-10	RES SMD 100 1% 1/16W
R1228	4016-25119-10	RES CHIP 0603 51.1 1%
R1229	4016-25119-10	RES CHIP 0603 51.1 1%
R1230	4016-22741-10	RES SMD 2.74K 1% 1/16W
R1231	4016-21002-10	RES SMD 10.0K 1% 1/16W
R1232	4016-22741-10	RES SMD 2.74K 1% 1/16W
R1233	4016-22210-10	RES SMD 221 1% 1/16W
R1234	4016-21002-10	RES SMD 10.0K 1% 1/16W
R1235	4016-21002-10	RES SMD 10.0K 1% 1/16W
R1236	4016-21002-10	RES SMD 10.0K 1% 1/16W
R1237	4016-25119-10	RES CHIP 0603 51.1 1%
R1238	4016-22741-10	RES SMD 2.74K 1% 1/16W
R1239	4016-21211-10	RES SMD 1.21K 1% 1/16W
R1240	4016-21829-10	RES CHIP 0603 18.2 1%
R1241	4016-21829-10	RES CHIP 0603 18.2 1%
R1242	4016-24750-10	RES SMD 475 1% 1/16W
R1243	4016-21002-10	RES SMD 10.0K 1% 1/16W
R1244	4016-30279-50	RES CHIP 2.7 5% 1\10W
R1245	4016-30279-50	RES CHIP 2.7 5% 1\10W
R1246	4016-21000-10	RES SMD 100 1% 1/16W
R1247	4016-21002-10	RES SMD 10.0K 1% 1/16W
R1248	4016-21002-10	RES SMD 10.0K 1% 1/16W
R1251	4016-21002-10	RES SMD 10.0K 1% 1/16W
R1252	4016-22741-10	RES SMD 2.74K 1% 1/16W
R1253	4016-23011-10	RES SMD 3.01K 1% 1/16W
R1254	4016-25119-10	RES CHIP 0603 51.1 1%
R1255	4016-21001-10	RES SMD 1.00K 1% 1/16W
R1800	4016-21000-10	RES SMD 100 1% 1/16W
R1801	4016-21001-10	RES SMD 1.00K 1% 1/16W
R1802	4016-21000-10	RES SMD 100 1% 1/16W
R1803	4016-21003-10	RES SMD 100K 1% 1/16W
R1804	4016-20100-50	RES CHIP 10 5% 1/16W
R1805	4016-21001-10	RES SMD 1.00K 1% 1/16W
R1806	4016-21001-10	RES SMD 1.00K 1% 1/16W
R1807	4016-23011-10	RES SMD 3.01K 1% 1/16W
R1808	4016-26810-10	RES SMD 681 1% 1/16W
R1809	4016-23322-10	RES SMD 33.2K 1% 1/16W
R1810	4016-21821-10	RES SMD 1.82K 1% 1/16W
R1811	4016-24750-10	RES SMD 475 1% 1/16W
R1812	4016-22002-10	RES SMD 20.0K 1% 1/16W
R1813	4016-21501-10	RES SMD 1.50K 1% 1/16W
R1814	4016-24751-10	RES SMD 4.75K 1% 1/16W
R1815	4016-21002-10	RES SMD 10.0K 1% 1/16W
R1816	4016-21000-10	RES SMD 100 1% 1/16W
R1817	4016-21211-10	RES SMD 1.21K 1% 1/16W
R1818	4016-24751-10	RES SMD 4.75K 1% 1/16W

Table 7-1. FTN6067A, LORD Board, Parts List

Reference Designation	Part No.	Description
R1819	4016-21001-10	RES SMD 1.00K 1% 1/16W
R1820	4016-21001-10	RES SMD 1.00K 1% 1/16W
R1821	4016-21001-10	RES SMD 1.00K 1% 1/16W
R1822	4016-23321-10	RES SMD 3.32K 1% 1/16W
R1823	4016-21002-10	RES SMD 10.0K 1% 1/16W
R1824	4016-21501-10	RES SMD 1.50K 1% 1/16W
R1825	4016-21000-10	RES SMD 100 1% 1/16W
R1826	4016-21000-10	RES SMD 100 1% 1/16W
R1827	4016-21000-10	RES SMD 100 1% 1/16W
R1828	4016-21000-10	RES SMD 100 1% 1/16W
R1829	4016-24751-10	RES SMD 4.75K 1% 1/16W
R1830	4016-24751-10	RES SMD 4.75K 1% 1/16W
R1831	4016-24751-10	RES SMD 4.75K 1% 1/16W
R1832	4016-60102-00	TRIMPOT 10K OHM
R1833	4016-25620-10	RES CHIP 0603 562 1%
R1834	4016-25620-10	RES CHIP 0603 562 1%
R1835	4016-23922-10	RES SMD 39.2K 1% 1/16W
R1836	4016-21501-10	RES SMD 1.50K 1% 1/16W
R1837	4016-21501-10	RES SMD 1.50K 1% 1/16W
R1838	4016-25620-10	RES CHIP 0603 562 1%
R1839	4016-23922-10	RES SMD 39.2K 1% 1/16W
R1840	4016-21501-10	RES SMD 1.50K 1% 1/16W
R1841	4016-21002-10	RES SMD 10.0K 1% 1/16W
R1842	4016-22210-10	RES SMD 221 1% 1/16W
R1843	4016-21003-10	RES SMD 100K 1% 1/16W
R1845	4016-22210-10	RES SMD 221 1% 1/16W
R1846	4016-22749-10	RES SMD 27.4 1% 1/16W
R1847	4016-21821-10	RES SMD 1.82K 1% 1/16W
R1848	4016-21002-10	RES SMD 10.0K 1% 1/16W
R1850	4016-23321-10	RES SMD 3.32K 1% 1/16W
R1851	4016-23011-10	RES SMD 3.01K 1% 1/16W
R1852	4016-23922-10	RES SMD 39.2K 1% 1/16W
R1853	4016-22740-10	RES SMD 274 1% 1/16W
R1854	4016-22740-10	RES SMD 274 1% 1/16W
R1855	4016-21821-10	RES SMD 1.82K 1% 1/16W
R1856	4016-23922-10	RES SMD 39.2K 1% 1/16W
R1857	4016-23321-10	RES SMD 3.32K 1% 1/16W
R1858	4016-23320-10	RES SMD 332 1% 1/16W
R1859	4016-21002-10	RES SMD 10.0K 1% 1/16W
R1860	4016-21001-10	RES SMD 1.00K 1% 1/16W
R1861	4016-21002-10	RES SMD 10.0K 1% 1/16W
R1862	4016-25620-10	RES CHIP 0603 562 1%
R1863	4016-21001-10	RES SMD 1.00K 1% 1/16W
R1864	4016-21001-10	RES SMD 1.00K 1% 1/16W
R1865	4016-24750-10	RES SMD 475 1% 1/16W
R1866	4016-21000-10	RES SMD 100 1% 1/16W
R1867	4016-21002-10	RES SMD 10.0K 1% 1/16W

Table 7-1. FTN6067A, LORD Board, Parts List

Reference Designation	Part No.	Description
R1868	4016-21001-10	RES SMD 1.00K 1% 1/16W
R1869	4016-21000-10	RES SMD 100 1% 1/16W
R1870	4016-21000-10	RES SMD 100 1% 1/16W
R1871	4016-26811-10	RES CHIP 0603 6.81K 1%
R1872	4016-26811-10	RES CHIP 0603 6.81K 1%
R1899	4016-25620-10	RES CHIP 0603 562 1%
R1911	4016-23321-10	RES SMD 3.32K 1% 1/16W
R1962	4016-25620-10	RES CHIP 0603 562 1%
R1998	4016-21002-10	RES SMD 10.0K 1% 1/16W
R1FL1	4016-51000-10	RES CHIP 0402 100
R1FL2	4016-51000-10	RES CHIP 0402 100
R1FL3	4016-51000-10	RES CHIP 0402 100
R1FL4	4016-51000-10	RES CHIP 0402 100
R1FL5	4016-51000-10	RES CHIP 0402 100
R1FL6	4016-51000-10	RES CHIP 0402 100
R1FL9	4016-51000-10	RES CHIP 0402 100
R1FL10	4016-51000-10	RES CHIP 0402 100
R1FL11	4016-51000-10	RES CHIP 0402 100
R1FL12	4016-51000-10	RES CHIP 0402 100
R1FL13	4016-51000-10	RES CHIP 0402 100
R1FL14	4016-51000-10	RES CHIP 0402 100
R1FL15	4016-51000-10	RES CHIP 0402 100
R1FL17	4016-51000-10	RES CHIP 0402 100
R1FL18	4016-51000-10	RES CHIP 0402 100
R1FL19	4016-51000-10	RES CHIP 0402 100
R1FL20	4016-51000-10	RES CHIP 0402 100
R1FL21	4016-51000-10	RES CHIP 0402 100
R1FL23	4016-21000-10	RES SMD 100 1% 1/16W
R1FL24	4016-21000-10	RES SMD 100 1% 1/16W
R1FL27	4016-51000-10	RES CHIP 0402 100
R1FL28	4016-51000-10	RES CHIP 0402 100
R1FL29	4016-21000-10	RES SMD 100 1% 1/16W
R1FL30	4016-51000-10	RES CHIP 0402 100
R1FL31	4016-51000-10	RES CHIP 0402 100
R1FL32	4016-21000-10	RES SMD 100 1% 1/16W
R1FL33	4016-51000-10	RES CHIP 0402 100
R2000	4016-22740-10	RES SMD 274 1% 1/16W
R2002	4016-20000-50	RES CHIP 0603 JUMPER
R2003	4016-20000-50	RES CHIP 0603 JUMPER
R2004	4016-20000-50	RES CHIP 0603 JUMPER
R2008	4016-24751-10	RES SMD 4.75K 1% 1/16W
R2009	4016-23322-10	RES SMD 33.2K 1% 1/16W
R2012	4016-24751-10	RES SMD 4.75K 1% 1/16W
R2017	4016-20100-50	RES CHIP 10 5% 1/16W
R2022	4016-28251-10	RES SMD 8.25K 1% 1/16W
R2026	4016-21300-10	RES SMD 130 1% 1/16W
R2029	4016-22749-10	RES SMD 27.4 1% 1/16W

Table 7-1. FTN6067A, LORD Board, Parts List

Reference Designation	Part No.	Description
R2034	4016-25119-10	RES CHIP 0603 51.1 1%
R2035	4016-25119-10	RES CHIP 0603 51.1 1%
R2036	4016-21500-10	RES SMD 150 1% 1/16W
R2037	4016-21500-10	RES SMD 150 1% 1/16W
R2038	4016-25110-10	RES SMD 511 1% 1/16W
R2043	4016-23321-10	RES SMD 3.32K 1% 1/16W
R2044	4016-23321-10	RES SMD 3.32K 1% 1/16W
R2045	4016-29091-10	RES SMD 9.09K 1% 1/16W
R2046	4016-25621-10	RES CHIP 0603 5.62K 1%
R2047	4016-24751-10	RES SMD 4.75K 1% 1/16W
R2048	4016-21001-10	RES SMD 1.00K 1% 1/16W
R2049	4016-21001-10	RES SMD 1.00K 1% 1/16W
R2050	4016-21001-10	RES SMD 1.00K 1% 1/16W
R2051	4016-21001-10	RES SMD 1.00K 1% 1/16W
R2052	4016-27501-10	RES SMD 7.5K 1% 1/16W
R2053	4016-21001-10	RES SMD 1.00K 1% 1/16W
R2054	4016-21001-10	RES SMD 1.00K 1% 1/16W
R2055	4016-21001-10	RES SMD 1.00K 1% 1/16W
R2056	4016-21001-10	RES SMD 1.00K 1% 1/16W
R2057	4016-25620-10	RES CHIP 0603 562 1%
R2058	4016-25620-10	RES CHIP 0603 562 1%
R2059	4016-25620-10	RES CHIP 0603 562 1%
R2060	4016-25620-10	RES CHIP 0603 562 1%
R2061	4016-23920-10	RES SMD 392 1% 1/16W
R2062	4016-23010-10	RES CHIP 0603 301 1%
R2063	4016-23010-10	RES CHIP 0603 301 1%
R2064	4016-23010-10	RES CHIP 0603 301 1%
R2065	4016-23010-10	RES CHIP 0603 301 1%
R2066	4016-23010-10	RES CHIP 0603 301 1%
R2067	4016-23010-10	RES CHIP 0603 301 1%
R2068	4016-23010-10	RES CHIP 0603 301 1%
R2069	4016-23010-10	RES CHIP 0603 301 1%
R2070	4016-23010-10	RES CHIP 0603 301 1%
R2071	4016-23010-10	RES CHIP 0603 301 1%
R2074	4016-22210-10	RES SMD 221 1% 1/16W
R2077	4016-21829-10	RES CHIP 0603 18.2 1%
R2078	4016-21829-10	RES CHIP 0603 18.2 1%
R2079	4016-21829-10	RES CHIP 0603 18.2 1%
R2080	4016-21829-10	RES CHIP 0603 18.2 1%
R2081	4016-21829-10	RES CHIP 0603 18.2 1%
R2082	4016-21829-10	RES CHIP 0603 18.2 1%
R2083	4016-21829-10	RES CHIP 0603 18.2 1%
R2084	4016-20100-50	RES CHIP 10 5% 1/16W
R2085	4016-20100-50	RES CHIP 10 5% 1/16W
R2086	4016-20100-50	RES CHIP 10 5% 1/16W
R2901	4016-21002-10	RES SMD 10.0K 1% 1/16W
R2903	4016-21829-10	RES CHIP 0603 18.2 1%

Table 7-1. FTN6067A, LORD Board, Parts List

Reference Designation	Part No.	Description
R2906	4016-21003-10	RES SMD 100K 1% 1/16W
R2FL20	4016-51002-10	RES CHIP 0402 10K
R3000	4016-26811-10	RES CHIP 0603 6.81K 1%
R3004	4016-21503-10	RES SMD 150K 1% 1/16W
R3006	4016-23322-10	RES SMD 33.2K 1% 1/16W
R3009	4016-24750-10	RES SMD 475 1% 1/16W
R3010	4016-23321-10	RES SMD 3.32K 1% 1/16W
R3013	4016-21001-10	RES SMD 1.00K 1% 1/16W
R3016	4016-25620-10	RES CHIP 0603 562 1%
R3017	4016-25620-10	RES CHIP 0603 562 1%
R3019	4016-21300-10	RES SMD 130 1% 1/16W
R3020	4016-20100-50	RES CHIP 10 5% 1/16W
R3021	4016-20100-50	RES CHIP 10 5% 1/16W
R3023	4016-91491-00	TERM NTC
R3024	4016-40109-50	RES 2512 1.0 5% 1W
R3025	4016-40109-50	RES 2512 1.0 5% 1W
R3027	4016-20000-50	RES CHIP 0603 JUMPER
R3029	4016-21503-10	RES SMD 150K 1% 1/16W
R3031	4016-21503-10	RES SMD 150K 1% 1/16W
R3034	4016-26192-10	RES CHIP 0603 61.9K 1%
R3043	4016-23322-10	RES SMD 33.2K 1% 1/16W
R3044	4016-23322-10	RES SMD 33.2K 1% 1/16W
R3046	4016-21001-10	RES SMD 1.00K 1% 1/16W
R3047	4016-21000-10	RES SMD 100 1% 1/16W
R3048	4016-21002-10	RES SMD 10.0K 1% 1/16W
R3050	4016-21503-10	RES SMD 150K 1% 1/16W
R3051	4016-23321-10	RES SMD 3.32K 1% 1/16W
R3052	4016-23321-10	RES SMD 3.32K 1% 1/16W
R3053	4016-21001-10	RES SMD 1.00K 1% 1/16W
R3054	4016-25620-10	RES CHIP 0603 562 1%
R3055	4016-25620-10	RES CHIP 0603 562 1%
R3056	4016-25620-10	RES CHIP 0603 562 1%
R3057	4016-20100-50	RES CHIP 10 5% 1/16W
R3058	4016-20100-50	RES CHIP 10 5% 1/16W
R3059	4016-21002-10	RES SMD 10.0K 1% 1/16W
R3060	4016-21002-10	RES SMD 10.0K 1% 1/16W
R3062	4016-21002-10	RES SMD 10.0K 1% 1/16W
R3063	4016-23322-10	RES SMD 33.2K 1% 1/16W
R3064	4016-21003-10	RES SMD 100K 1% 1/16W
R3075	4016-21503-10	RES SMD 150K 1% 1/16W
R3076	4016-21002-10	RES SMD 10.0K 1% 1/16W
R3300	4016-25119-10	RES CHIP 0603 51.1 1%
R3301	4016-20100-50	RES CHIP 10 5% 1/16W
R3302	4016-21000-10	RES SMD 100 1% 1/16W
R3303	4016-25119-10	RES CHIP 0603 51.1 1%
R3310	4016-20106-50	RES CHIP 10M 5% 1/16W
R3330	4016-21002-10	RES SMD 10.0K 1% 1/16W

Table 7-1. FTN6067A, LORD Board, Parts List

Reference Designation	Part No.	Description
R3350	4016-21002-10	RES SMD 10.0K 1% 1/16W
R3600	4016-20106-50	RES CHIP 10M 5% 1/16W
R3942	4016-21002-10	RES SMD 10.0K 1% 1/16W
R3FL20	4016-24751-10	RES SMD 4.75K 1% 1/16W
R4000	4016-21002-10	RES SMD 10.0K 1% 1/16W
R4001	4016-21002-10	RES SMD 10.0K 1% 1/16W
R4002	4016-22002-10	RES SMD 20.0K 1% 1/16W
R4003	4016-21002-10	RES SMD 10.0K 1% 1/16W
R4004	4016-21002-10	RES SMD 10.0K 1% 1/16W
R4005	4016-22002-10	RES SMD 20.0K 1% 1/16W
R4006	4016-23922-10	RES SMD 39.2K 1% 1/16W
R4007	4016-21002-10	RES SMD 10.0K 1% 1/16W
R4008	4016-23011-10	RES SMD 3.01K 1% 1/16W
R4009	4016-22001-10	RES SMD 2.0K 1% 1/16W
R4011	4016-22002-10	RES SMD 20.0K 1% 1/16W
R4012	4016-22002-10	RES SMD 20.0K 1% 1/16W
R4013	4016-25620-10	RES CHIP 0603 562 1%
R4014	4016-22210-10	RES SMD 221 1% 1/16W
R4015	4016-22210-10	RES SMD 221 1% 1/16W
R4016	4016-25621-10	RES CHIP 0603 5.62K 1%
R4017	4016-26811-10	RES CHIP 0603 6.81K 1%
R4018	4016-21002-10	RES SMD 10.0K 1% 1/16W
R4019	4016-22002-10	RES SMD 20.0K 1% 1/16W
R4020	4016-23011-10	RES SMD 3.01K 1% 1/16W
R4021	4016-23013-10	RES SMD 301K 1% 1/16W
R4022	4016-23922-10	RES SMD 39.2K 1% 1/16W
R4024	4016-21003-10	RES SMD 100K 1% 1/16W
R4025	4016-22002-10	RES SMD 20.0K 1% 1/16W
R4026	4016-21003-10	RES SMD 100K 1% 1/16W
R4028	4016-21472-10	RES SMD 14.7K 1% 1/16W
R4030	4016-22001-10	RES SMD 2.0K 1% 1/16W
R4033	4016-22002-10	RES SMD 20.0K 1% 1/16W
R4037	4016-22741-10	RES SMD 2.74K 1% 1/16W
R4041	4016-21002-10	RES SMD 10.0K 1% 1/16W
R4043	4016-22002-10	RES SMD 20.0K 1% 1/16W
R4044	4016-25620-10	RES CHIP 0603 562 1%
R4047	4016-21002-10	RES SMD 10.0K 1% 1/16W
R4049	4016-21002-10	RES SMD 10.0K 1% 1/16W
R4050	4016-26811-10	RES CHIP 0603 6.81K 1%
R4051	4016-24751-10	RES SMD 4.75K 1% 1/16W
R4052	4016-21002-10	RES SMD 10.0K 1% 1/16W
R4053	4016-21003-10	RES SMD 100K 1% 1/16W
R4054	4016-21002-10	RES SMD 10.0K 1% 1/16W
R4055	4016-22742-10	RES SMD 27.4K 1% 1/16W
R4056	4016-21002-10	RES SMD 10.0K 1% 1/16W
R4057	4016-21002-10	RES SMD 10.0K 1% 1/16W
R4058	4016-23321-10	RES SMD 3.32K 1% 1/16W

Table 7-1. FTN6067A, LORD Board, Parts List

Reference Designation	Part No.	Description
R4059	4016-21003-10	RES SMD 100K 1% 1/16W
R4060	4016-22740-10	RES SMD 274 1% 1/16W
R4061	4016-22002-10	RES SMD 20.0K 1% 1/16W
R4062	4016-21002-10	RES SMD 10.0K 1% 1/16W
R4063	4016-21002-10	RES SMD 10.0K 1% 1/16W
R4064	4016-21001-10	RES SMD 1.00K 1% 1/16W
R4065	4016-21002-10	RES SMD 10.0K 1% 1/16W
R4066	4016-22742-10	RES SMD 27.4K 1% 1/16W
R4067	4016-22001-10	RES SMD 2.0K 1% 1/16W
R4068	4016-25112-10	RES SMD 51.1K 1% 1/16W
R4069	4016-21503-10	RES SMD 150K 1% 1/16W
R4070	4016-21503-10	RES SMD 150K 1% 1/16W
R4071	4016-23922-10	RES SMD 39.2K 1% 1/16W
R4072	4016-21503-10	RES SMD 150K 1% 1/16W
R4073	4016-21002-10	RES SMD 10.0K 1% 1/16W
R4074	4016-21002-10	RES SMD 10.0K 1% 1/16W
R4075	4016-22740-10	RES SMD 274 1% 1/16W
R4076	4016-21002-10	RES SMD 10.0K 1% 1/16W
R4077	4016-25112-10	RES SMD 51.1K 1% 1/16W
R4078	4016-23922-10	RES SMD 39.2K 1% 1/16W
R4079	4016-22001-10	RES SMD 2.0K 1% 1/16W
R4080	4016-22742-10	RES SMD 27.4K 1% 1/16W
R4081	4016-21829-10	RES CHIP 0603 18.2 1%
R4082	4016-21002-10	RES SMD 10.0K 1% 1/16W
R4083	4016-22002-10	RES SMD 20.0K 1% 1/16W
R4084	4016-21002-10	RES SMD 10.0K 1% 1/16W
R4085	4016-21001-10	RES SMD 1.00K 1% 1/16W
R4086	4016-26811-10	RES CHIP 0603 6.81K 1%
R4087	4016-22741-10	RES SMD 2.74K 1% 1/16W
R4088	4016-22002-10	RES SMD 20.0K 1% 1/16W
R4200	4016-21003-10	RES SMD 100K 1% 1/16W
R4401	4016-23321-10	RES SMD 3.32K 1% 1/16W
R5000	4016-20000-50	RES CHIP 0603 JUMPER
R5001	4016-24751-10	RES SMD 4.75K 1% 1/16W
R5002	4016-23922-10	RES SMD 39.2K 1% 1/16W
R5003	4016-23922-10	RES SMD 39.2K 1% 1/16W
R5004	4016-23922-10	RES SMD 39.2K 1% 1/16W
R5005	4016-23922-10	RES SMD 39.2K 1% 1/16W
R5006	4016-23922-10	RES SMD 39.2K 1% 1/16W
R5007	4016-23922-10	RES SMD 39.2K 1% 1/16W
R5009	4016-21003-10	RES SMD 100K 1% 1/16W
R5013	4016-24751-10	RES SMD 4.75K 1% 1/16W
R5014	4016-24751-10	RES SMD 4.75K 1% 1/16W
R5016	4016-20000-50	RES CHIP 0603 JUMPER
R5017	4016-23922-10	RES SMD 39.2K 1% 1/16W
R5020	4016-20000-50	RES CHIP 0603 JUMPER
R5021	4016-23922-10	RES SMD 39.2K 1% 1/16W

Table 7-1. FTN6067A, LORD Board, Parts List

Reference Designation	Part No.	Description
R5022	4016-21001-10	RES SMD 1.00K 1% 1/16W
R5023	4016-20000-50	RES CHIP 0603 JUMPER
R5024	4016-21001-10	RES SMD 1.00K 1% 1/16W
R5025	4016-20000-50	RES CHIP 0603 JUMPER
R5027	4016-21503-10	RES SMD 150K 1% 1/16W
R5029	4016-24751-10	RES SMD 4.75K 1% 1/16W
R5030	4016-24751-10	RES SMD 4.75K 1% 1/16W
R5034	4016-20000-50	RES CHIP 0603 JUMPER
R5035	4016-22001-10	RES SMD 2.0K 1% 1/16W
R5036	4016-21501-10	RES SMD 1.50K 1% 1/16W
R5037	4016-23922-10	RES SMD 39.2K 1% 1/16W
R5038	4016-23922-10	RES SMD 39.2K 1% 1/16W
R5039	4016-20106-50	RES CHIP 10M 5% 1/16W
R5040	4016-23922-10	RES SMD 39.2K 1% 1/16W
R5041	4016-23922-10	RES SMD 39.2K 1% 1/16W
R5042	4016-22743-10	RES SMD 274K 1% 1/16W
R5043	4016-23922-10	RES SMD 39.2K 1% 1/16W
R5044	4016-21002-10	RES SMD 10.0K 1% 1/16W
R5046	4016-22001-10	RES SMD 2.0K 1% 1/16W
R5047	4016-23922-10	RES SMD 39.2K 1% 1/16W
R5048	4016-23922-10	RES SMD 39.2K 1% 1/16W
R5050	4016-24751-10	RES SMD 4.75K 1% 1/16W
R5051	4016-23922-10	RES SMD 39.2K 1% 1/16W
R5052	4016-24751-10	RES SMD 4.75K 1% 1/16W
R5053	4016-23922-10	RES SMD 39.2K 1% 1/16W
R5054	4016-23922-10	RES SMD 39.2K 1% 1/16W
R5055	4016-21002-10	RES SMD 10.0K 1% 1/16W
R5056	4016-21000-10	RES SMD 100 1% 1/16W
R5059	4016-23922-10	RES SMD 39.2K 1% 1/16W
R5060	4016-21000-10	RES SMD 100 1% 1/16W
R5063	4016-23922-10	RES SMD 39.2K 1% 1/16W
R5065	4016-23922-10	RES SMD 39.2K 1% 1/16W
R5066	4016-21002-10	RES SMD 10.0K 1% 1/16W
R5067	4016-22000-10	RES SMD 200 1% 1/16W
R5068	4016-21002-10	RES SMD 10.0K 1% 1/16W
R5070	4016-20000-50	RES CHIP 0603 JUMPER
R5071	4016-23922-10	RES SMD 39.2K 1% 1/16W
R5072	4016-23922-10	RES SMD 39.2K 1% 1/16W
R5075	4016-20000-50	RES CHIP 0603 JUMPER
R5100	4016-21002-10	RES SMD 10.0K 1% 1/16W
R5101	4016-21002-10	RES SMD 10.0K 1% 1/16W
R5104	4016-21002-10	RES SMD 10.0K 1% 1/16W
R6000	4016-23922-10	RES SMD 39.2K 1% 1/16W
R6002	4016-21002-10	RES SMD 10.0K 1% 1/16W
R6009	4016-23922-10	RES SMD 39.2K 1% 1/16W
R6016	4016-23922-10	RES SMD 39.2K 1% 1/16W
R6018	4016-23922-10	RES SMD 39.2K 1% 1/16W

Table 7-1. FTN6067A, LORD Board, Parts List

Reference Designation	Part No.	Description
R6020	4016-23922-10	RES SMD 39.2K 1% 1/16W
R6022	4016-21821-10	RES SMD 1.82K 1% 1/16W
R6023	4016-21821-10	RES SMD 1.82K 1% 1/16W
R6024	4016-23922-10	RES SMD 39.2K 1% 1/16W
R6026	4016-21211-10	RES SMD 1.21K 1% 1/16W
R6027	4016-19090-10	RES CHIP 909 1% 1/8W
R6028	4016-23922-10	RES SMD 39.2K 1% 1/16W
R6030	4016-23922-10	RES SMD 39.2K 1% 1/16W
R6032	4016-21002-10	RES SMD 10.0K 1% 1/16W
R6033	4016-27500-10	RES CHIP 0603 750 1%
R6034	4016-27500-10	RES CHIP 0603 750 1%
R6035	4016-21829-10	RES CHIP 0603 18.2 1%
R6036	4016-27500-10	RES CHIP 0603 750 1%
R6037	4016-19090-10	RES CHIP 909 1% 1/8W
R6038	4016-21211-10	RES SMD 1.21K 1% 1/16W
R6039	4016-21821-10	RES SMD 1.82K 1% 1/16W
R6040	4016-21821-10	RES SMD 1.82K 1% 1/16W
R6041	4016-21000-10	RES SMD 100 1% 1/16W
R6042	4016-21002-10	RES SMD 10.0K 1% 1/16W
R7000	4016-24750-10	RES SMD 475 1% 1/16W
R7001	4016-24750-10	RES SMD 475 1% 1/16W
R7002	4016-24750-10	RES SMD 475 1% 1/16W
R7003	4016-24750-10	RES SMD 475 1% 1/16W
R7006	4016-24750-10	RES SMD 475 1% 1/16W
R7007	4016-24752-10	RES SMD 47.5K 1% 1/16W
R9000	4016-22742-10	RES SMD 27.4K 1% 1/16W
R9020	4016-22742-10	RES SMD 27.4K 1% 1/16W
R9040	4016-22742-10	RES SMD 27.4K 1% 1/16W
R9060	4016-22742-10	RES SMD 27.4K 1% 1/16W
R9062	4016-22000-10	RES SMD 200 1% 1/16W
R9063	4016-22000-10	RES SMD 200 1% 1/16W
R9064	4016-22000-10	RES SMD 200 1% 1/16W
R9065	4016-22000-10	RES SMD 200 1% 1/16W
R9100	4016-21829-10	RES CHIP 0603 18.2 1%
R9200	4016-20100-50	RES CHIP 10 5% 1/16W
R9300	4016-21829-10	RES CHIP 0603 18.2 1%
R9400	4016-20100-50	RES CHIP 10 5% 1/16W
R9409	4016-23922-10	RES SMD 39.2K 1% 1/16W
R9410	4016-23922-10	RES SMD 39.2K 1% 1/16W
R9411	4016-23922-10	RES SMD 39.2K 1% 1/16W
R9412	4016-23922-10	RES SMD 39.2K 1% 1/16W
R9417	4016-23922-10	RES SMD 39.2K 1% 1/16W
R9418	4016-23922-10	RES SMD 39.2K 1% 1/16W
R9419	4016-23922-10	RES SMD 39.2K 1% 1/16W
R9420	4016-23922-10	RES SMD 39.2K 1% 1/16W
R9421	4016-23922-10	RES SMD 39.2K 1% 1/16W
R9422	4016-23922-10	RES SMD 39.2K 1% 1/16W

Table 7-1. FTN6067A, LORD Board, Parts List

Reference Designation	Part No.	Description
R9423	4016-23922-10	RES SMD 39.2K 1% 1/16W
R9427	4016-23922-10	RES SMD 39.2K 1% 1/16W
R9464	4016-21001-10	RES SMD 1.00K 1% 1/16W
R9465	4016-21001-10	RES SMD 1.00K 1% 1/16W
R9489	4016-20000-50	RES CHIP 0603 JUMPER
R9493	4016-20000-50	RES CHIP 0603 JUMPER
R9496	4016-23922-10	RES SMD 39.2K 1% 1/16W
R9497	4016-20000-50	RES CHIP 0603 JUMPER
R9498	4016-20000-50	RES CHIP 0603 JUMPER
R9500	4016-23922-10	RES SMD 39.2K 1% 1/16W
R9501	4016-23922-10	RES SMD 39.2K 1% 1/16W
R9502	4016-23922-10	RES SMD 39.2K 1% 1/16W
R9503	4016-23922-10	RES SMD 39.2K 1% 1/16W
R9509	4016-20000-50	RES CHIP 0603 JUMPER
R9510	4016-20000-50	RES CHIP 0603 JUMPER
R9513	4016-20000-50	RES CHIP 0603 JUMPER
R9514	4016-20000-50	RES CHIP 0603 JUMPER
R9516	4016-24751-10	RES SMD 4.75K 1% 1/16W
R9519	4016-23922-10	RES SMD 39.2K 1% 1/16W
R9520	4016-23922-10	RES SMD 39.2K 1% 1/16W
R9521	4016-23922-10	RES SMD 39.2K 1% 1/16W
R9522	4016-23922-10	RES SMD 39.2K 1% 1/16W
R9523	4016-23922-10	RES SMD 39.2K 1% 1/16W
R9524	4016-23922-10	RES SMD 39.2K 1% 1/16W
R9525	4016-23922-10	RES SMD 39.2K 1% 1/16W
R9526	4016-23922-10	RES SMD 39.2K 1% 1/16W
R9527	4016-24750-10	RES SMD 475 1% 1/16W
R9528	4016-24750-10	RES SMD 475 1% 1/16W
R9529	4016-24750-10	RES SMD 475 1% 1/16W
R9530	4016-24750-10	RES SMD 475 1% 1/16W
R9531	4016-22002-10	RES SMD 20.0K 1% 1/16W
R9532	4016-21003-10	RES SMD 100K 1% 1/16W
R9533	4016-21003-10	RES SMD 100K 1% 1/16W
R9535	4016-22001-10	RES SMD 2.0K 1% 1/16W
R9536	4016-23321-10	RES SMD 3.32K 1% 1/16W
R9537	4016-22740-10	RES SMD 274 1% 1/16W
R9538	4016-22740-10	RES SMD 274 1% 1/16W
R9539	4016-21000-10	RES SMD 100 1% 1/16W
R9540	4016-21000-10	RES SMD 100 1% 1/16W
R9541	4016-21000-10	RES SMD 100 1% 1/16W
R9542	4016-21000-10	RES SMD 100 1% 1/16W
R9543	4016-21000-10	RES SMD 100 1% 1/16W
R9544	4016-21000-10	RES SMD 100 1% 1/16W
R9545	4016-21000-10	RES SMD 100 1% 1/16W
R9546	4016-21000-10	RES SMD 100 1% 1/16W
R9547	4016-21000-10	RES SMD 100 1% 1/16W
R9549	4016-20000-50	RES CHIP 0603 JUMPER

Table 7-1. FTN6067A, LORD Board, Parts List

Reference Designation	Part No.	Description
R9550	4016-20000-50	RES CHIP 0603 JUMPER
R9551	4016-20000-50	RES CHIP 0603 JUMPER
R9552	4016-20000-50	RES CHIP 0603 JUMPER
R9553	4016-20000-50	RES CHIP 0603 JUMPER
R9554	4016-20000-50	RES CHIP 0603 JUMPER
R9557	4016-20000-50	RES CHIP 0603 JUMPER
R9558	4016-20000-50	RES CHIP 0603 JUMPER
R9559	4016-21503-10	RES SMD 150K 1% 1/16W
R9560	4016-23922-10	RES SMD 39.2K 1% 1/16W
R9561	4016-23922-10	RES SMD 39.2K 1% 1/16W
R9562	4016-23922-10	RES SMD 39.2K 1% 1/16W
R9563	4016-23922-10	RES SMD 39.2K 1% 1/16W
R9564	4016-23922-10	RES SMD 39.2K 1% 1/16W
R9565	4016-23922-10	RES SMD 39.2K 1% 1/16W
R9566	4016-23922-10	RES SMD 39.2K 1% 1/16W
R9567	4016-23922-10	RES SMD 39.2K 1% 1/16W
R9568	4016-23922-10	RES SMD 39.2K 1% 1/16W
R9569	4016-23922-10	RES SMD 39.2K 1% 1/16W
R9570	4016-23922-10	RES SMD 39.2K 1% 1/16W
R9571	4016-23922-10	RES SMD 39.2K 1% 1/16W
R9572	4016-23922-10	RES SMD 39.2K 1% 1/16W
R9573	4016-23922-10	RES SMD 39.2K 1% 1/16W
R9574	4016-23922-10	RES SMD 39.2K 1% 1/16W
R9575	4016-23922-10	RES SMD 39.2K 1% 1/16W
R9576	4016-22742-10	RES SMD 27.4K 1% 1/16W
R9577	4016-22002-10	RES SMD 20.0K 1% 1/16W
R9578	4016-22002-10	RES SMD 20.0K 1% 1/16W
R9579	4016-22002-10	RES SMD 20.0K 1% 1/16W
R9580	4016-22002-10	RES SMD 20.0K 1% 1/16W
R9581	4016-22002-10	RES SMD 20.0K 1% 1/16W
R9582	4016-21002-10	RES SMD 10.0K 1% 1/16W
R9583	4016-21002-10	RES SMD 10.0K 1% 1/16W
R9584	4016-21002-10	RES SMD 10.0K 1% 1/16W
R9585	4016-21002-10	RES SMD 10.0K 1% 1/16W
R9586	4016-21002-10	RES SMD 10.0K 1% 1/16W
R9587	4016-21002-10	RES SMD 10.0K 1% 1/16W
R9588	4016-21002-10	RES SMD 10.0K 1% 1/16W
R9589	4016-21002-10	RES SMD 10.0K 1% 1/16W
R9590	4016-21002-10	RES SMD 10.0K 1% 1/16W
R9591	4016-21002-10	RES SMD 10.0K 1% 1/16W
R9592	4016-21002-10	RES SMD 10.0K 1% 1/16W
R9593	4016-21002-10	RES SMD 10.0K 1% 1/16W
R9594	4016-21002-10	RES SMD 10.0K 1% 1/16W
R9595	4016-21503-10	RES SMD 150K 1% 1/16W
R9596	4016-21503-10	RES SMD 150K 1% 1/16W
R9597	4016-24751-10	RES SMD 4.75K 1% 1/16W
R9598	4016-24751-10	RES SMD 4.75K 1% 1/16W

Table 7-1. FTN6067A, LORD Board, Parts List

Reference Designation	Part No.	Description
R9599	4016-21001-10	RES SMD 1.00K 1% 1/16W
R9600	4016-21001-10	RES SMD 1.00K 1% 1/16W
R9601	4016-25620-10	RES CHIP 0603 562 1%
R9602	4016-25620-10	RES CHIP 0603 562 1%
R9603	4016-25620-10	RES CHIP 0603 562 1%
R9605	4016-20000-50	RES CHIP 0603 JUMPER
R9606	4016-20000-50	RES CHIP 0603 JUMPER
R9607	4016-23922-10	RES SMD 39.2K 1% 1/16W
R9608	4016-23922-10	RES SMD 39.2K 1% 1/16W
U0001	4021-60063-50	HCMOS SHF REG 74HC595
U1000	4014-60015-00	MIXER 500MHZ LO-10DB
U1100	4021-20170-54	QUAD OP AMP.
U1104	2072-21039-00	IC D/A CONV 6BIT 4CHAN
U1105	4021-44014-64	VHC HEX SCHMIDT TRIG.
U1106	2072-21042-00	IC 9.3V REG
U1107	2072-21042-00	IC 9.3V REG
U1108	4014-60015-00	MIXER 500MHZ LO-10DB
U1109	4021-44014-64	VHC HEX SCHMIDT TRIG.
U1110	4021-20170-54	QUAD OP AMP.
U1111	4021-70007-54	CMOS BLT ANL SW
U1112	4021-60063-50	HCMOS SHF REG 74HC595
U1113	4021-31161-50	COUNT 4BIT 74HC161
U1114	4021-31161-50	COUNT 4BIT 74HC161
U1115	2072-21056-00	CONVERTER A TO D 1MHZ 1
U1900	4021-20170-54	QUAD OP AMP.
U2002	2112-21805-00	DIVIDE 8/2,4,8
U2003	2112-21805-00	DIVIDE 8/2,4,8
U2004	2072-21044-00	IC ADJ. LOW DROPOUT POS
U2009	2072-21058-00	MMIC AMP 5V G=23DB
U2010	2072-21058-00	MMIC AMP 5V G=23DB
U3000	4021-20170-54	QUAD OP AMP.
U3001	2072-24012-00	EPIC OSC 16.8MHZ SINE W
U3004	4021-20010-54	V-REG ADJ LP2951
U4000	4021-20170-54	QUAD OP AMP.
U4002	2072-21035-00	AUDIO PA AMP.
U4003	4021-20170-54	QUAD OP AMP.
U5001	2072-21048-00	IC 256KX16,512KX8 FLASH
U5005	4021-44014-64	VHC HEX SCHMIDT TRIG.
U5006	2388-21830-00	IC 14053 SOIC
U5007	2388-21830-00	IC 14053 SOIC
U5008A	2072-21036-00	IC 68HC16 W/SCI,QUEUD S
U5009	2072-21053-00	SRAM 128K*8BIT MEMORY
U5010	2072-21053-00	SRAM 128K*8BIT MEMORY
U5014	2072-21105-00	VOLTAGE DETECTOR
U6000	2072-21031-00	ASIC D.S.M
U6021	2072-21045-00	REG 5V POS 100MA
U6022	2072-21046-00	REG 8V POS 100MA

Table 7-1. FTN6067A, LORD Board, Parts List

Reference Designation	Part No.	Description
U6023	2072-21046-00	REG 8V POS 100MA
U6024	2072-21045-00	REG 5V POS 100MA
U6025	2072-21045-00	REG 5V POS 100MA
U6033	2072-21055-00	REGULATOR 5V TO 3.3V
U6038	2072-21052-00	SRAM 64K*24BIT MEMORY
U6040	2072-21054-00	CODEC 16BIT 22KSPS SIGN
U6042	2072-21050-00	DSP 56303 100MHZ CLOCK
U6043	2072-21051-00	EEPROM 32K*8BIT
U6062	2072-21057-00	RS-232 TRANSCEIVERS 5V
U6063	2072-21057-00	RS-232 TRANSCEIVERS 5V
U6065	4021-35000-54	AC QUAD 2-INP NAND
U6068	2072-33137-00	OCTAL D-TYPE FLIP FLOP
U6069	2072-33137-00	OCTAL D-TYPE FLIP FLOP
U6070	2072-33137-00	OCTAL D-TYPE FLIP FLOP
U6075	2072-21123-00	SYNTHESIZER PLL
U6076	2072-21123-00	SYNTHESIZER PLL
U6077	4021-44014-64	VHC HEX SCHMIDT TRIG.
U6078	2072-21125-00	Quad UART with 16-Byte
U6079	4021-44138-64	VHC 3 TO 8 DECODER
U6080	4021-44014-64	VHC HEX SCHMIDT TRIG.
U6081	2072-21113-00	POT DIG UP/DW 128TAP LO
U6082	4021-20170-54	QUAD OP AMP.
U6084	2388-21830-00	IC 14053 SOIC
U6085	2388-21830-00	IC 14053 SOIC
U6086	2072-21124-00	VARICAP 39PF
VR1	4021-10420-35	ZENER 3.3V 5% 225MW
VR2	4021-10420-35	ZENER 3.3V 5% 225MW
VR4	2072-21028-00	DIODE 10V 5% 1.5W
VR5	2072-21028-00	DIODE 10V 5% 1.5W
VR1500	4021-10421-35	ZENER 5.6V 5% 225MW
VR4000	4021-10422-35	ZENER 27V 5% 225MW
VR5001	4021-10421-35	ZENER 5.6V 5% 225MW
VR5002	4021-10421-35	ZENER 5.6V 5% 225MW
VR5003	4021-10421-35	ZENER 5.6V 5% 225MW
Y5002	2072-24011-00	OSC 38.4 KHZ +-25PPM 48

Intentionally Left Blank

HIGH-POWER BOARD
Model FTN6068A
Printed Circuit Board Details



TOP SIDE

BOTTOM SIDE

HIGH-POWER BOARD

Model FTN6068A

Schematic Diagram

Harmonic Filter Drivers Section

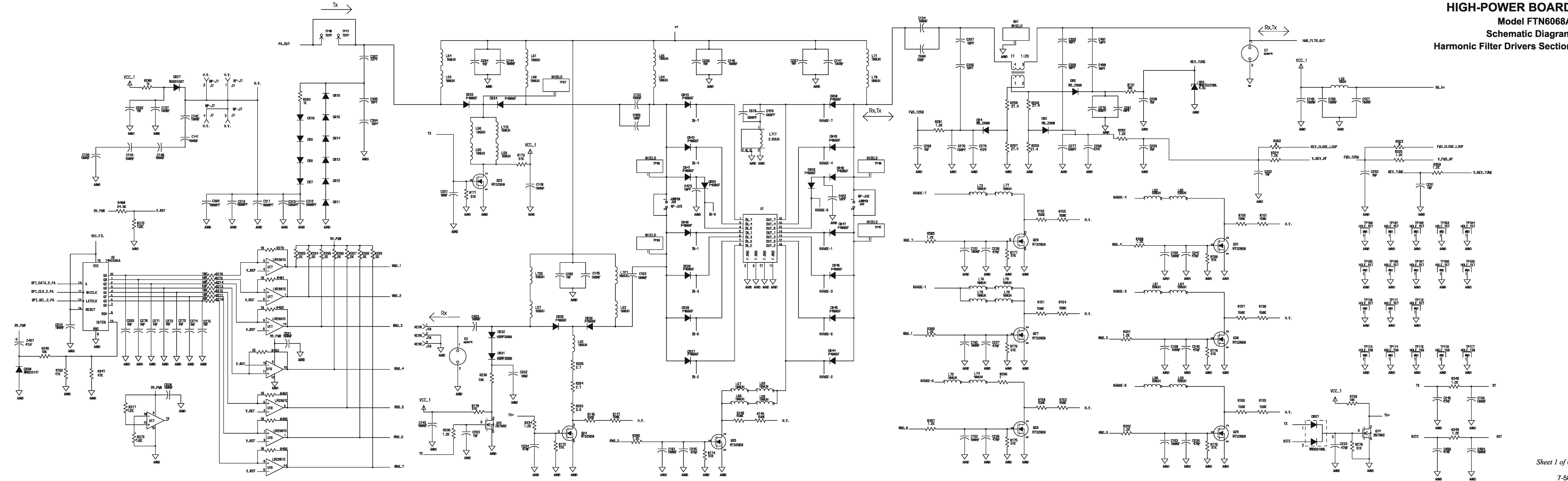

HIGH-POWER BOARD

Model FTN6068A

Schematic Diagram
DC Regulators Section

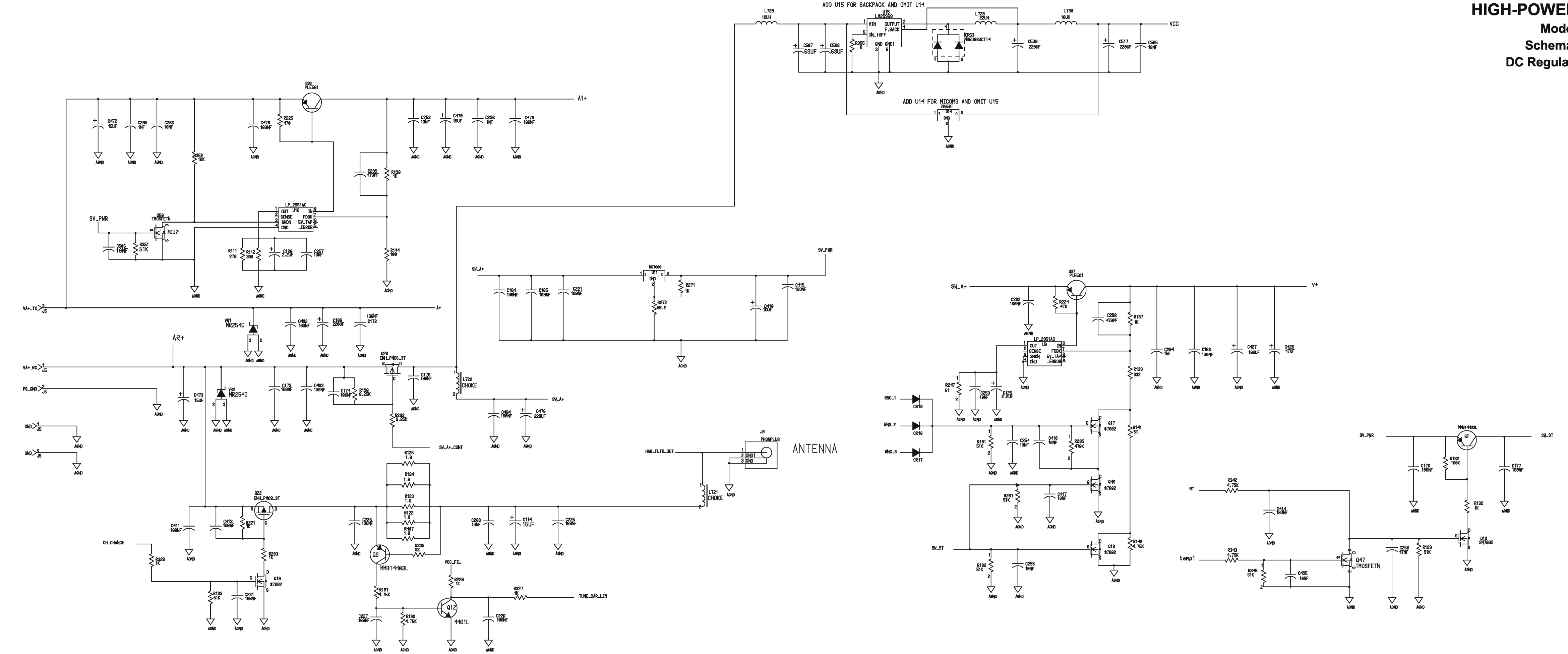

HIGH-POWER BOARD
Model FTN6068A
Schematic Diagram
Power Amplifier Section

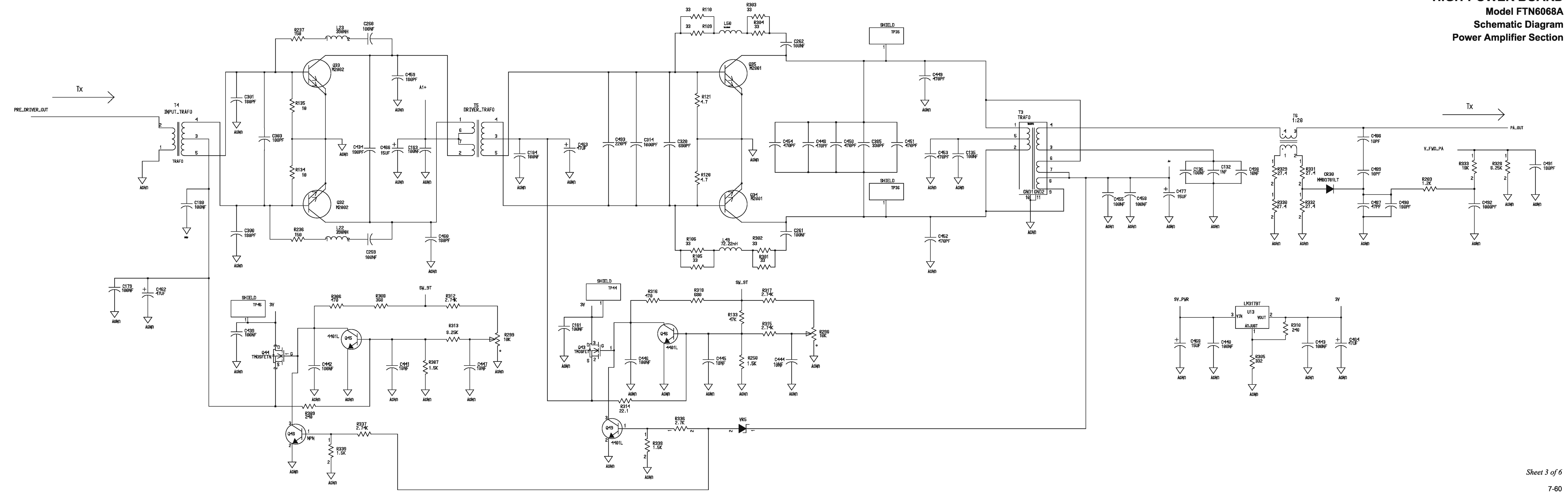

HIGH-POWER BOARD

Model FTN6068A

Schematic Diagram

Drivers Section

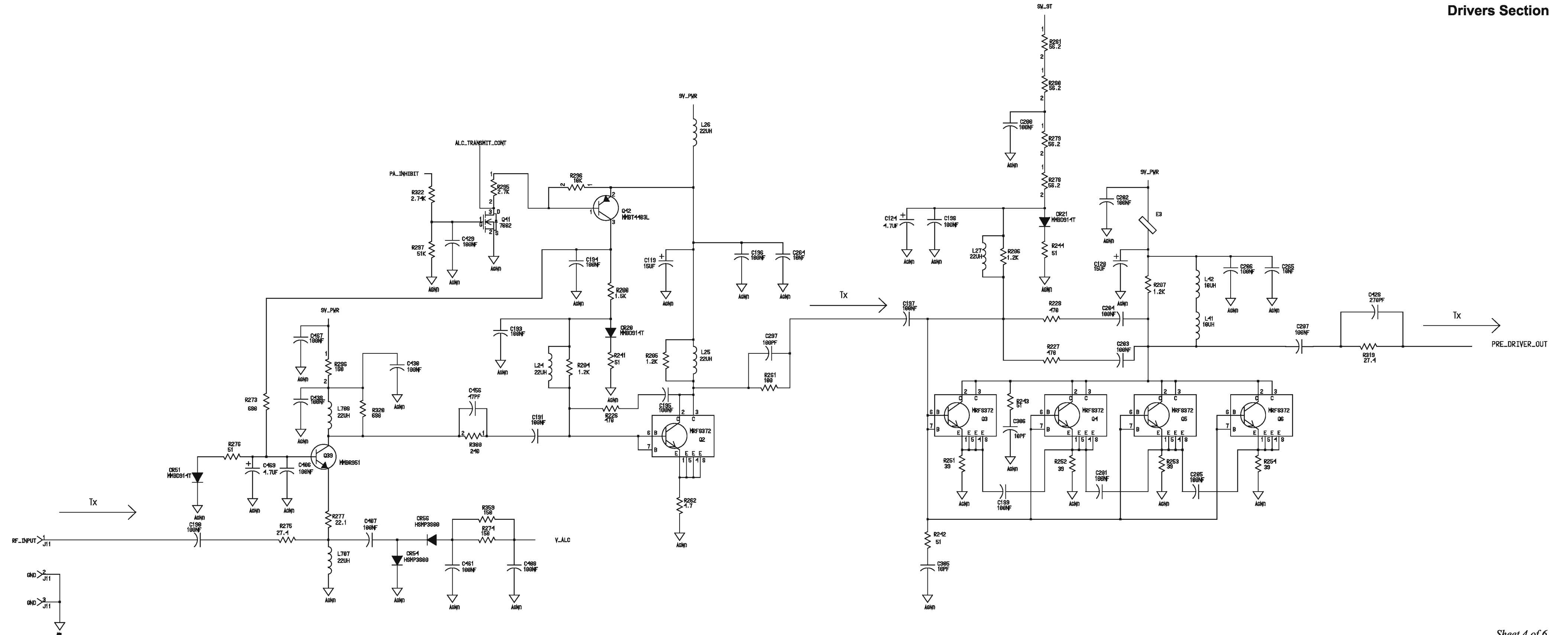

HIGH-POWER BOARD
Model FTN6068A
Schematic Diagram
ALC Section

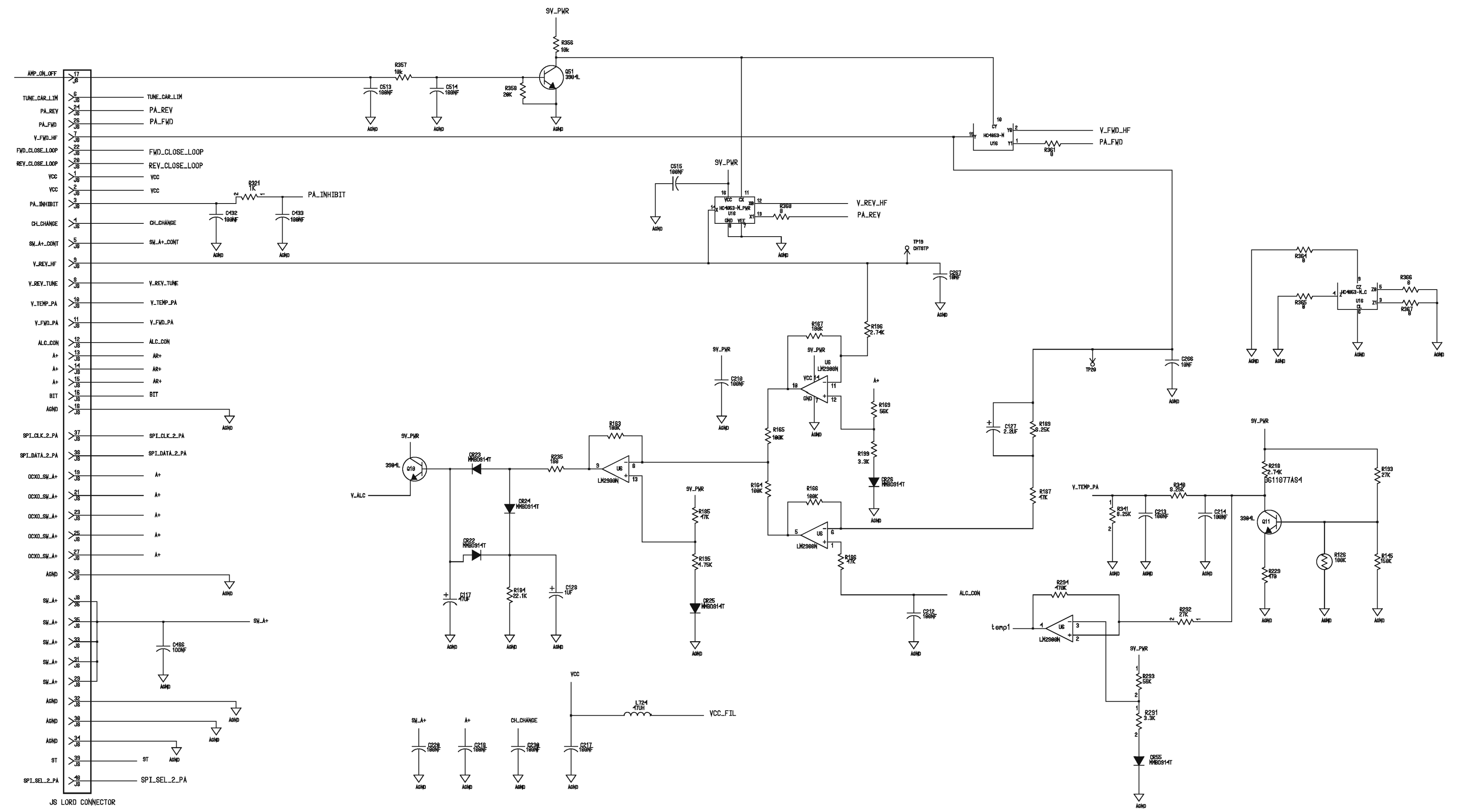

HIGH-POWER BOARD
Model FTN6068A
Schematic Diagram
Harmonic Filter Section

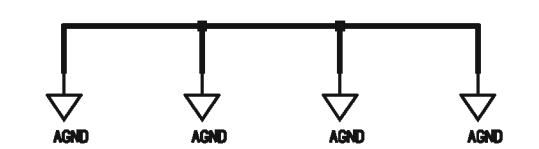
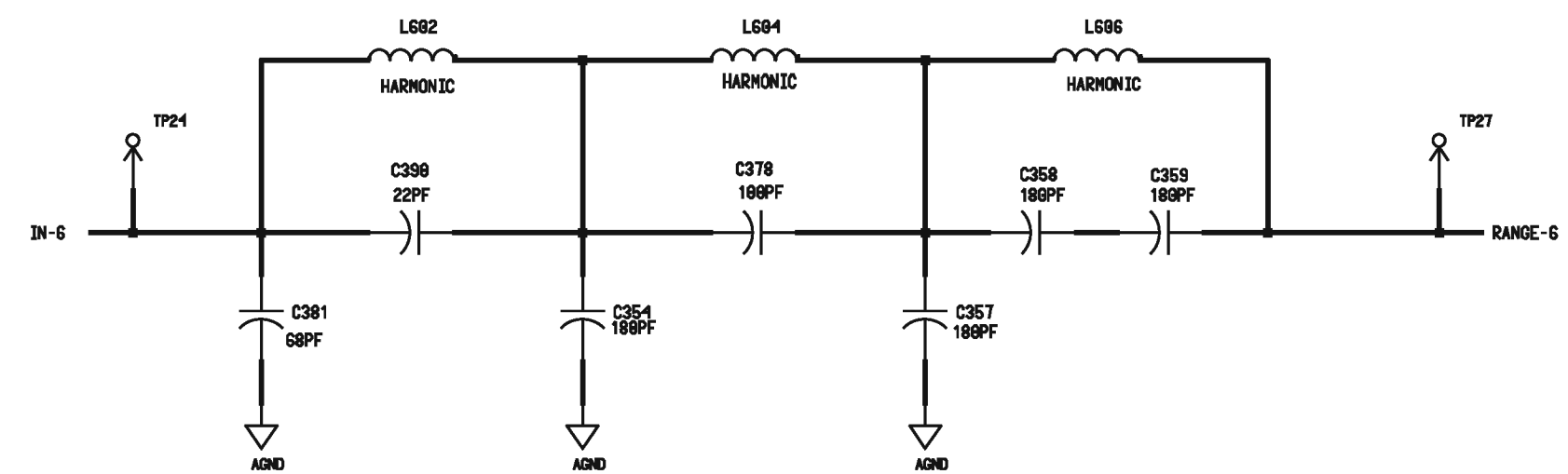
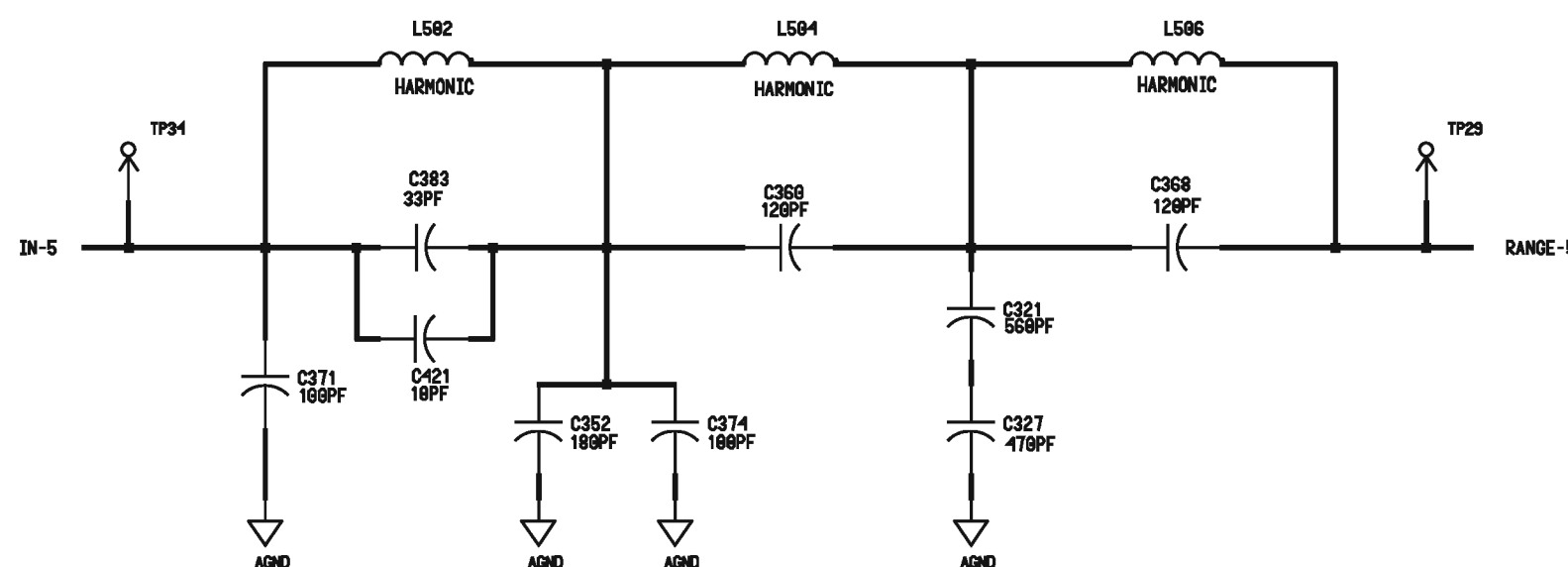
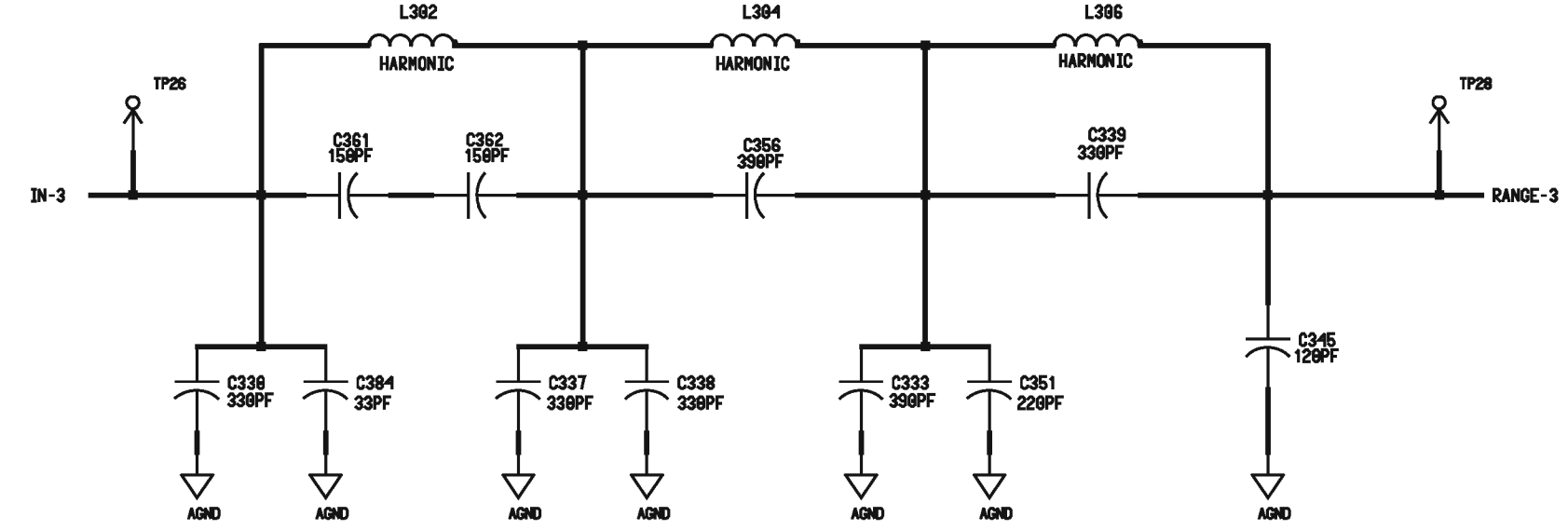
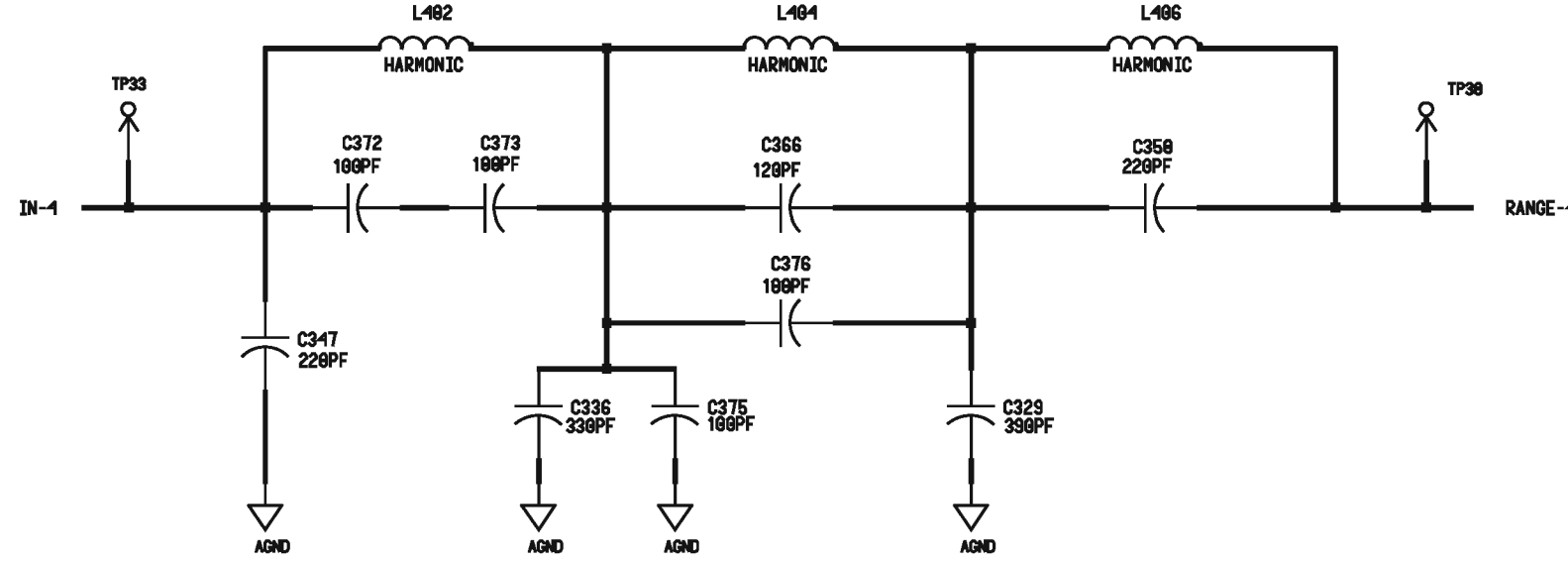
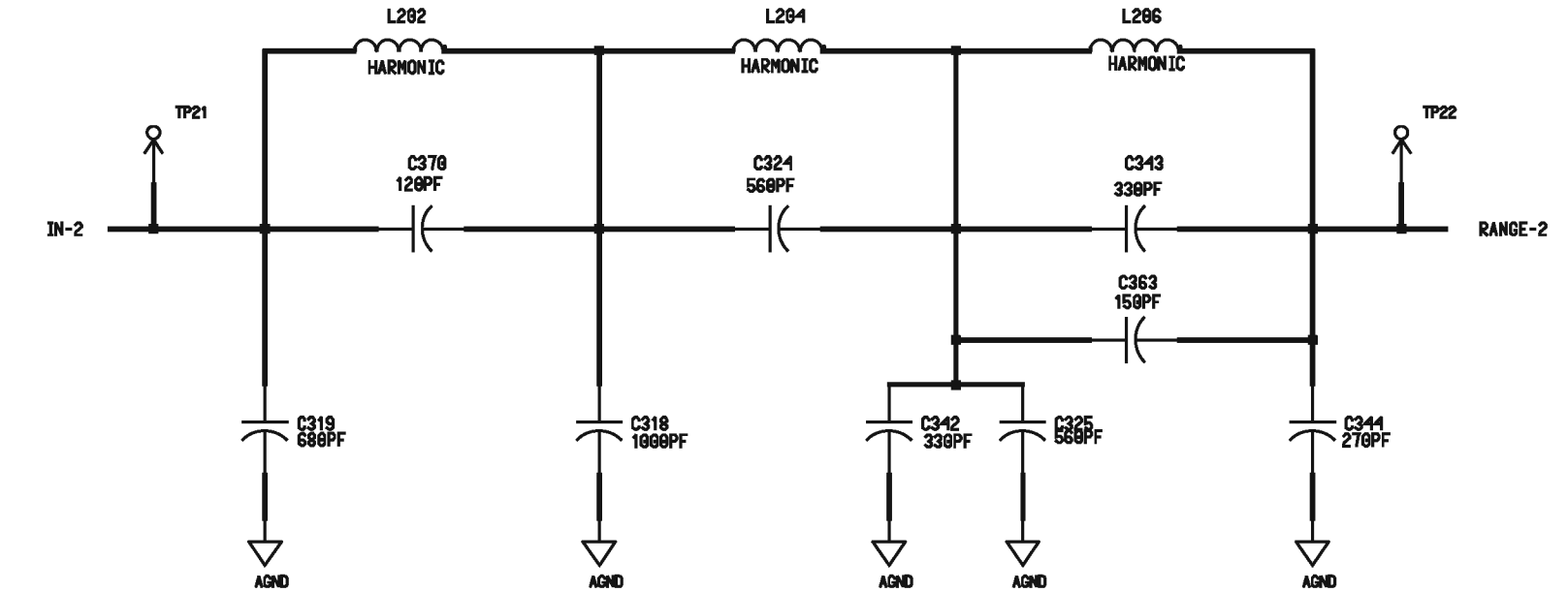
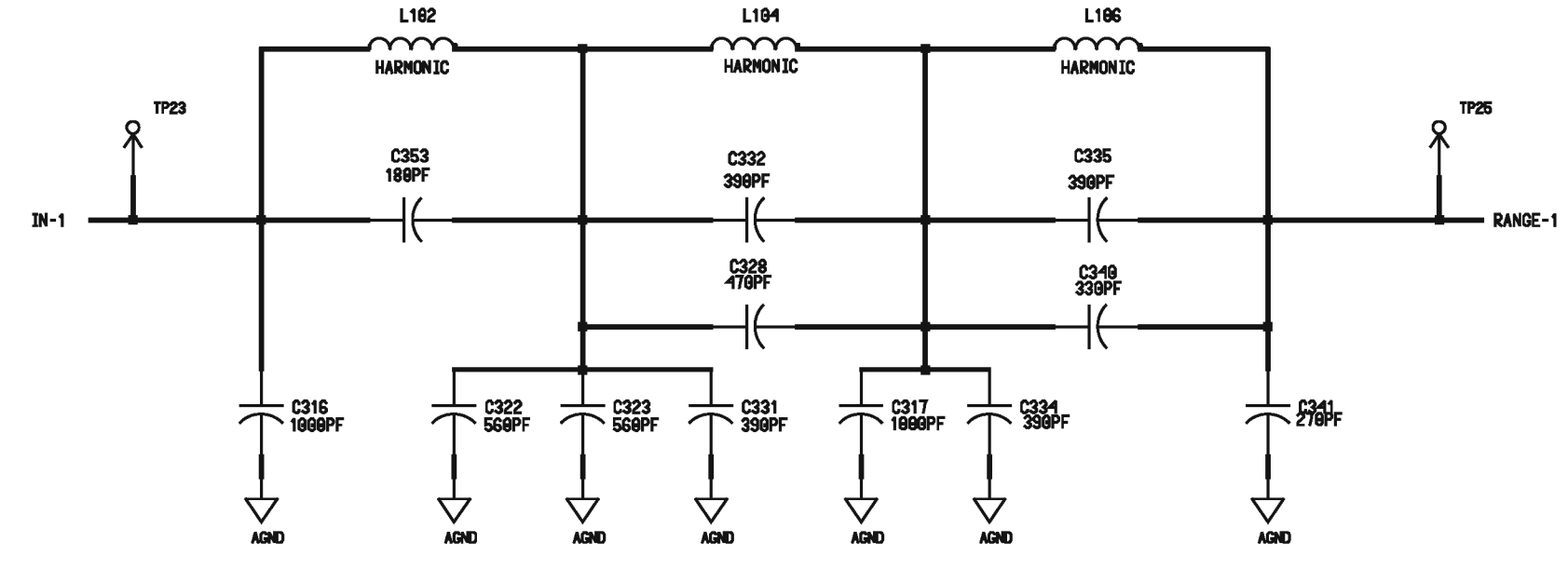
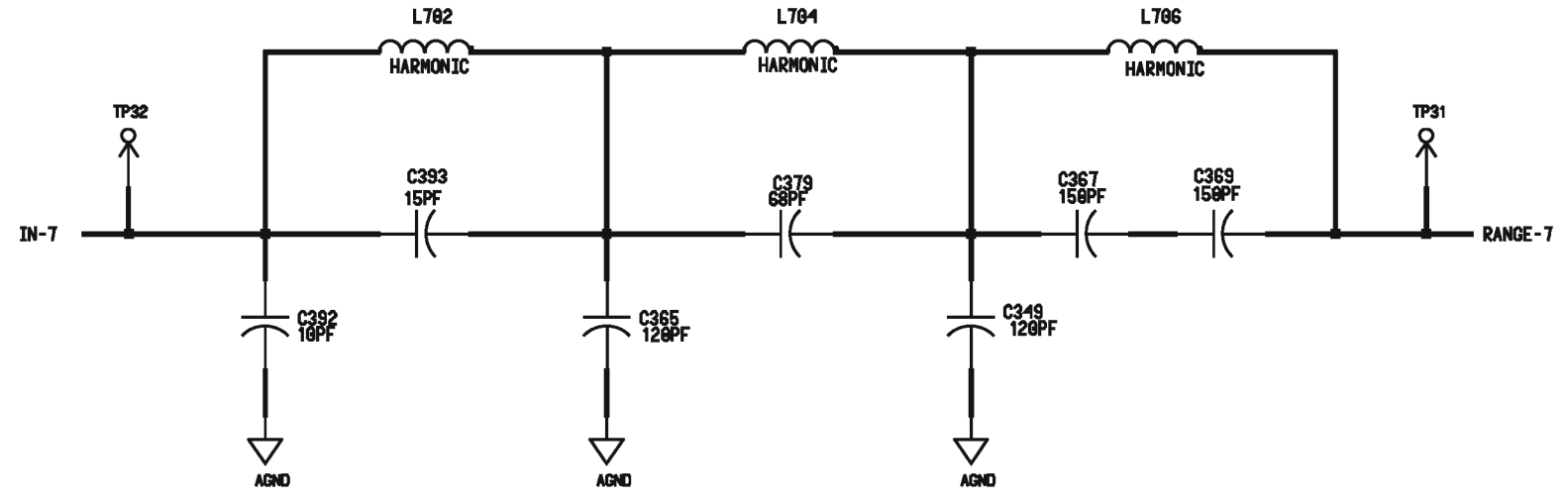

Table 7-2. FTN6068A, High-Power Board, Parts List

Reference Designation	Part No.	Description
C106	2072-17108-00	CAP ALU 220UF 35V
C114	2072-17105-00	CAP TANT CHIP 15UF 25V
C117	2072-17106-00	CAP TANT CHIP 47UF 10V
C119	2072-17105-00	CAP TANT CHIP 15UF 25V
C120	2072-17105-00	CAP TANT CHIP 15UF 25V
C124	2072-17103-00	CAP TANT CHIP 4.7UF 10V
C125	2072-17102-00	CAP TANT CHIP 2.2UF 20V
C126	2072-17102-00	CAP TANT CHIP 2.2UF 20V
C127	2072-17102-00	CAP TANT CHIP 2.2UF 20V
C128	4017-80101-02	CAP CHIP TAN 1UF 25V
C132	4017-25775-00	CAP 1206 NPO 1000P 5% 5
C133	4017-20183-00	CAP 1812 X7R 100N 100V
C134	4017-20183-00	CAP 1812 X7R 100N 100V
C135	4017-20183-00	CAP 1812 X7R 100N 100V
C136	4017-20183-00	CAP 1812 X7R 100N 100V
C137	4017-20085-00	CAP CHIP CER X7R 100NF
C138	4017-20085-00	CAP CHIP CER X7R 100NF
C139	4017-20085-00	CAP CHIP CER X7R 100NF
C140	4017-20085-00	CAP CHIP CER X7R 100NF
C141	4017-20085-00	CAP CHIP CER X7R 100NF
C142	4017-20085-00	CAP CHIP CER X7R 100NF
C143	4017-20085-00	CAP CHIP CER X7R 100NF
C144	4017-20085-00	CAP CHIP CER X7R 100NF
C145	4017-20085-00	CAP CHIP CER X7R 100NF
C146	4017-20085-00	CAP CHIP CER X7R 100NF
C147	4017-20085-00	CAP CHIP CER X7R 100NF
C148	4017-20085-00	CAP CHIP CER X7R 100NF
C149	4017-20085-00	CAP CHIP CER X7R 100NF
C151	4017-20085-00	CAP CHIP CER X7R 100NF
C152	4017-20085-00	CAP CHIP CER X7R 100NF
C153	4017-20085-00	CAP CHIP CER X7R 100NF
C156	4017-20085-00	CAP CHIP CER X7R 100NF
C157	4017-20085-00	CAP CHIP CER X7R 100NF
C158	4017-20085-00	CAP CHIP CER X7R 100NF
C159	4017-20085-00	CAP CHIP CER X7R 100NF
C160	4017-20085-00	CAP CHIP CER X7R 100NF
C161	4017-20085-00	CAP CHIP CER X7R 100NF
C162	4017-20085-00	CAP CHIP CER X7R 100NF
C163	4017-20085-00	CAP CHIP CER X7R 100NF
C164	4017-20085-00	CAP CHIP CER X7R 100NF
C165	4017-20085-00	CAP CHIP CER X7R 100NF
C166	4017-20085-00	CAP CHIP CER X7R 100NF
C172	4017-20085-00	CAP CHIP CER X7R 100NF
C173	4017-20085-00	CAP CHIP CER X7R 100NF
C174	4017-20085-00	CAP CHIP CER X7R 100NF
C176	4017-20085-00	CAP CHIP CER X7R 100NF

Table 7-2. FTN6068A, High-Power Board, Parts List

Reference Designation	Part No.	Description
C177	4017-20085-00	CAP CHIP CER X7R 100NF
C178	4017-20085-00	CAP CHIP CER X7R 100NF
C179	4017-20085-00	CAP CHIP CER X7R 100NF
C180	4017-20085-00	CAP CHIP CER X7R 100NF
C181	4017-20085-00	CAP CHIP CER X7R 100NF
C183	4017-20085-00	CAP CHIP CER X7R 100NF
C184	4017-20085-00	CAP CHIP CER X7R 100NF
C190	4017-20085-00	CAP CHIP CER X7R 100NF
C191	4017-20085-00	CAP CHIP CER X7R 100NF
C193	4017-20085-00	CAP CHIP CER X7R 100NF
C194	4017-20085-00	CAP CHIP CER X7R 100NF
C195	4017-20085-00	CAP CHIP CER X7R 100NF
C196	4017-20085-00	CAP CHIP CER X7R 100NF
C197	4017-20085-00	CAP CHIP CER X7R 100NF
C198	4017-20085-00	CAP CHIP CER X7R 100NF
C199	4017-20085-00	CAP CHIP CER X7R 100NF
C200	4017-20085-00	CAP CHIP CER X7R 100NF
C201	4017-20085-00	CAP CHIP CER X7R 100NF
C202	4017-20085-00	CAP CHIP CER X7R 100NF
C203	4017-20085-00	CAP CHIP CER X7R 100NF
C204	4017-20085-00	CAP CHIP CER X7R 100NF
C205	4017-20085-00	CAP CHIP CER X7R 100NF
C206	4017-20085-00	CAP CHIP CER X7R 100NF
C207	4017-20085-00	CAP CHIP CER X7R 100NF
C210	4017-20085-00	CAP CHIP CER X7R 100NF
C212	4017-20085-00	CAP CHIP CER X7R 100NF
C213	4017-20085-00	CAP CHIP CER X7R 100NF
C214	4017-20085-00	CAP CHIP CER X7R 100NF
C217	4017-20085-00	CAP CHIP CER X7R 100NF
C218	4017-20085-00	CAP CHIP CER X7R 100NF
C220	4017-20085-00	CAP CHIP CER X7R 100NF
C221	4017-20085-00	CAP CHIP CER X7R 100NF
C225	4017-20085-00	CAP CHIP CER X7R 100NF
C226	4017-20085-00	CAP CHIP CER X7R 100NF
C227	4017-20085-00	CAP CHIP CER X7R 100NF
C228	4017-20085-00	CAP CHIP CER X7R 100NF
C230	4017-20085-00	CAP CHIP CER X7R 100NF
C231	4017-20085-00	CAP CHIP CER X7R 100NF
C232	4017-20085-00	CAP CHIP CER X7R 100NF
C233	2072-17027-00	CAP CHIP X7R 47NF
C234	2072-17027-00	CAP CHIP X7R 47NF
C235	2072-17027-00	CAP CHIP X7R 47NF
C236	2072-17027-00	CAP CHIP X7R 47NF
C237	2072-17027-00	CAP CHIP X7R 47NF
C238	2072-17027-00	CAP CHIP X7R 47NF
C239	2072-17027-00	CAP CHIP X7R 47NF
C240	2072-17027-00	CAP CHIP X7R 47NF

Table 7-2. FTN6068A, High-Power Board, Parts List

Reference Designation	Part No.	Description
C241	2072-17027-00	CAP CHIP X7R 47NF
C245	2072-17027-00	CAP CHIP X7R 47NF
C250	2072-17027-00	CAP CHIP X7R 47NF
C251	4017-20102-00	CAP CHIP 10NF 200V
C252	4017-20102-00	CAP CHIP 10NF 200V
C253	4017-20102-00	CAP CHIP 10NF 200V
C254	4017-20102-00	CAP CHIP 10NF 200V
C255	4017-20102-00	CAP CHIP 10NF 200V
C256	4017-20102-00	CAP CHIP 10NF 200V
C257	4017-20102-00	CAP CHIP 10NF 200V
C258	4017-20102-00	CAP CHIP 10NF 200V
C259	4017-20085-00	CAP CHIP CER X7R 100NF
C260	4017-20085-00	CAP CHIP CER X7R 100NF
C261	4017-20085-00	CAP CHIP CER X7R 100NF
C262	4017-20085-00	CAP CHIP CER X7R 100NF
C264	4017-20102-00	CAP CHIP 10NF 200V
C265	4017-20102-00	CAP CHIP 10NF 200V
C266	4017-20102-00	CAP CHIP 10NF 200V
C267	4017-20102-00	CAP CHIP 10NF 200V
C268	4017-20102-00	CAP CHIP 10NF 200V
C269	4017-25101-00	CAP CHIP CER 1NF 200V
C270	4017-25101-00	CAP CHIP CER 1NF 200V
C271	4017-25101-00	CAP CHIP CER 1NF 200V
C272	4017-25101-00	CAP CHIP CER 1NF 200V
C273	4017-25101-00	CAP CHIP CER 1NF 200V
C274	4017-25101-00	CAP CHIP CER 1NF 200V
C275	4017-25101-00	CAP CHIP CER 1NF 200V
C276	2072-17024-00	CAP CHIP 180PF 100V
C277	2072-17024-00	CAP CHIP 180PF 100V
C278	4017-25071-00	CAP CHIP CER COG 100PF
C279	2072-17023-00	CAP CHIP 47PF 100V
C280	2072-17023-00	CAP CHIP 47PF 100V
C281	2072-17022-00	CAP CHIP 0805 10PF 100V
C282	4017-25775-00	CAP 1206 NPO 1000P 5% 5
C283	4017-25775-00	CAP 1206 NPO 1000P 5% 5
C284	4017-25775-00	CAP 1206 NPO 1000P 5% 5
C285	4017-25775-00	CAP 1206 NPO 1000P 5% 5
C286	4017-25775-00	CAP 1206 NPO 1000P 5% 5
C287	4017-25775-00	CAP 1206 NPO 1000P 5% 5
C288	4017-25775-00	CAP 1206 NPO 1000P 5% 5
C289	4017-25775-00	CAP 1206 NPO 1000P 5% 5
C290	4017-25775-00	CAP 1206 NPO 1000P 5% 5
C291	4017-25775-00	CAP 1206 NPO 1000P 5% 5
C292	4017-25775-00	CAP 1206 NPO 1000P 5% 5
C293	4017-25775-00	CAP 1206 NPO 1000P 5% 5
C294	4017-25775-00	CAP 1206 NPO 1000P 5% 5
C295	4017-25775-00	CAP 1206 NPO 1000P 5% 5

Table 7-2. FTN6068A, High-Power Board, Parts List

Reference Designation	Part No.	Description
C296	4017-25775-00	CAP 1206 NPO 1000P 5% 5
C297	2072-17006-00	CAP CHIP 1206 100PF 5%
C298	2072-17055-00	CAP CHIP CL1 +/-30 470P
C299	2072-17055-00	CAP CHIP CL1 +/-30 470P
C300	2072-17007-00	CAP CHIP 1206 180PF 5%
C301	2072-17007-00	CAP CHIP 1206 180PF 5%
C303	2072-17006-00	CAP CHIP 1206 100PF 5%
C305	2072-17002-00	CAP CHIP 1206 10PF 5%
C306	2072-17002-00	CAP CHIP 1206 10PF 5%
C309	4017-25433-00	CAP CER CHIP 1000PF 500
C310	4017-25433-00	CAP CER CHIP 1000PF 500
C311	4017-25433-00	CAP CER CHIP 1000PF 500
C312	4017-25433-00	CAP CER CHIP 1000PF 500
C313	4017-25433-00	CAP CER CHIP 1000PF 500
C314	4017-25433-00	CAP CER CHIP 1000PF 500
C316	4017-25433-00	CAP CER CHIP 1000PF 500
C317	4017-25433-00	CAP CER CHIP 1000PF 500
C318	4017-25433-00	CAP CER CHIP 1000PF 500
C319	4017-25431-00	CAP CER CHIP 680PF 500V
C320	4017-25431-00	CAP CER CHIP 680PF 500V
C321	4017-25430-00	CAP CER CHIP 560PF 500V
C322	4017-25430-00	CAP CER CHIP 560PF 500V
C323	4017-25430-00	CAP CER CHIP 560PF 500V
C324	4017-25430-00	CAP CER CHIP 560PF 500V
C325	4017-25430-00	CAP CER CHIP 560PF 500V
C327	4017-25429-00	CAP CER CHIP 470PF 500V
C328	4017-25429-00	CAP CER CHIP 470PF 500V
C329	4017-25428-00	CAP CER CHIP 390PF 500V
C330	4017-25427-00	CAP CER CHIP 330PF 500V
C331	4017-25428-00	CAP CER CHIP 390PF 500V
C332	4017-25428-00	CAP CER CHIP 390PF 500V
C333	4017-25428-00	CAP CER CHIP 390PF 500V
C334	4017-25428-00	CAP CER CHIP 390PF 500V
C335	4017-25428-00	CAP CER CHIP 390PF 500V
C336	4017-25427-00	CAP CER CHIP 330PF 500V
C337	4017-25427-00	CAP CER CHIP 330PF 500V
C338	4017-25427-00	CAP CER CHIP 330PF 500V
C339	4017-25427-00	CAP CER CHIP 330PF 500V
C340	4017-25427-00	CAP CER CHIP 330PF 500V
C341	4017-25426-00	CAP CER CHIP 270PF 500V
C342	4017-25427-00	CAP CER CHIP 330PF 500V
C343	4017-25427-00	CAP CER CHIP 330PF 500V
C344	4017-25426-00	CAP CER CHIP 270PF 500V
C345	4017-25422-00	CAP CER CHIP 120PF 500V
C347	4017-25425-00	CAP CER CHIP 220PF 500V
C349	4017-60027-20	CAP PORC. 120PF 2%
C350	4017-25425-00	CAP CER CHIP 220PF 500V

Table 7-2. FTN6068A, High-Power Board, Parts List

Reference Designation	Part No.	Description
C351	4017-25425-00	CAP CER CHIP 220PF 500V
C352	4017-25424-00	CAP CER CHIP 180PF 500V
C353	4017-25424-00	CAP CER CHIP 180PF 500V
C354	4017-25424-00	CAP CER CHIP 180PF 500V
C356	4017-25428-00	CAP CER CHIP 390PF 500V
C357	4017-25424-00	CAP CER CHIP 180PF 500V
C358	4017-25424-00	CAP CER CHIP 180PF 500V
C359	4017-25424-00	CAP CER CHIP 180PF 500V
C360	4017-60027-20	CAP PORC. 120PF 2%
C361	4017-25423-00	CAP CER CHIP 150PF 500V
C362	4017-25423-00	CAP CER CHIP 150PF 500V
C363	4017-25423-00	CAP CER CHIP 150PF 500V
C365	4017-60027-20	CAP PORC. 120PF 2%
C366	4017-60027-20	CAP PORC. 120PF 2%
C367	4017-25423-00	CAP CER CHIP 150PF 500V
C368	4017-60027-20	CAP PORC. 120PF 2%
C369	4017-25423-00	CAP CER CHIP 150PF 500V
C370	4017-60027-20	CAP PORC. 120PF 2%
C371	4017-60026-20	CAP PORC. 100PF 2%
C372	4017-60026-20	CAP PORC. 100PF 2%
C373	4017-60026-20	CAP PORC. 100PF 2%
C374	4017-60026-20	CAP PORC. 100PF 2%
C375	4017-60026-20	CAP PORC. 100PF 2%
C376	4017-60026-20	CAP PORC. 100PF 2%
C378	4017-60026-20	CAP PORC. 100PF 2%
C379	4017-60024-20	CAP PORC. 68PF 2%
C381	4017-60024-20	CAP PORC. 68PF 2%
C383	4017-25415-00	CAP CER CHIP 33PF 500V
C384	4017-25415-00	CAP CER CHIP 33PF 500V
C385	4017-25427-00	CAP CER CHIP 330PF 500V
C387	4017-25413-00	CAP CER CHIP 22PF 500V
C390	4017-25413-00	CAP CER CHIP 22PF 500V
C392	4017-25409-00	CAP CER CHIP 10PF 500V
C393	4017-25411-00	CAP CER CHIP 15PF 500V
C394	4017-25409-00	CAP CER CHIP 10PF 500V
C395	4017-25409-00	CAP CER CHIP 10PF 500V
C396	4017-25409-00	CAP CER CHIP 10PF 500V
C397	4017-25409-00	CAP CER CHIP 10PF 500V
C398	4017-25409-00	CAP CER CHIP 10PF 500V
C399	4017-25409-00	CAP CER CHIP 10PF 500V
C400	4017-25409-00	CAP CER CHIP 10PF 500V
C401	4017-25409-00	CAP CER CHIP 10PF 500V
C403	4017-20085-00	CAP CHIP CER X7R 100NF
C404	4017-20085-00	CAP CHIP CER X7R 100NF
C406	4017-20085-00	CAP CHIP CER X7R 100NF
C407	4017-20085-00	CAP CHIP CER X7R 100NF
C408	4017-20085-00	CAP CHIP CER X7R 100NF

Table 7-2. FTN6068A, High-Power Board, Parts List

Reference Designation	Part No.	Description
C409	2072-17027-00	CAP CHIP X7R 47NF
C410	2072-17104-00	CAP TANT CHIP 10UF 16V
C411	4017-20085-00	CAP CHIP CER X7R 100NF
C413	4017-20085-00	CAP CHIP CER X7R 100NF
C414	4017-20085-00	CAP CHIP CER X7R 100NF
C415	4017-20085-00	CAP CHIP CER X7R 100NF
C417	4017-20102-00	CAP CHIP 10NF 200V
C418	4017-20102-00	CAP CHIP 10NF 200V
C419	4017-25431-00	CAP CER CHIP 680PF 500V
C421	4017-25409-00	CAP CER CHIP 10PF 500V
C422	4017-25409-00	CAP CER CHIP 10PF 500V
C423	4017-25409-00	CAP CER CHIP 10PF 500V
C426	2072-17106-00	CAP TANT CHIP 47UF 10V
C427	4017-80202-02	CAP LOW ESR 100UF 10V
C428	2072-17008-00	CAP CHIP 1206 270PF 5%
C429	4017-20085-00	CAP CHIP CER X7R 100NF
C430	4017-20085-00	CAP CHIP CER X7R 100NF
C432	4017-20085-00	CAP CHIP CER X7R 100NF
C433	4017-20085-00	CAP CHIP CER X7R 100NF
C434	2072-17007-00	CAP CHIP 1206 180PF 5%
C438	4017-20085-00	CAP CHIP CER X7R 100NF
C439	4017-20085-00	CAP CHIP CER X7R 100NF
C440	4017-20085-00	CAP CHIP CER X7R 100NF
C441	4017-20102-00	CAP CHIP 10NF 200V
C442	4017-20085-00	CAP CHIP CER X7R 100NF
C443	4017-20085-00	CAP CHIP CER X7R 100NF
C444	4017-20102-00	CAP CHIP 10NF 200V
C445	4017-20102-00	CAP CHIP 10NF 200V
C446	4017-20085-00	CAP CHIP CER X7R 100NF
C447	4017-20102-00	CAP CHIP 10NF 200V
C448	4017-25429-00	CAP CER CHIP 470PF 500V
C449	4017-25429-00	CAP CER CHIP 470PF 500V
C450	4017-25429-00	CAP CER CHIP 470PF 500V
C451	4017-25429-00	CAP CER CHIP 470PF 500V
C452	4017-25429-00	CAP CER CHIP 470PF 500V
C453	4017-25429-00	CAP CER CHIP 470PF 500V
C454	4017-25429-00	CAP CER CHIP 470PF 500V
C455	4017-20085-00	CAP CHIP CER X7R 100NF
C456	2072-17005-00	CAP CHIP 1206 47PF 5%
C458	4017-20085-00	CAP CHIP CER X7R 100NF
C459	2072-17007-00	CAP CHIP 1206 180PF 5%
C460	2072-17007-00	CAP CHIP 1206 180PF 5%
C461	4017-20085-00	CAP CHIP CER X7R 100NF
C462	2072-17106-00	CAP TANT CHIP 47UF 10V
C463	2072-17106-00	CAP TANT CHIP 47UF 10V
C464	2072-17106-00	CAP TANT CHIP 47UF 10V
C466	2072-17105-00	CAP TANT CHIP 15UF 25V

Table 7-2. FTN6068A, High-Power Board, Parts List

Reference Designation	Part No.	Description
C467	4017-20085-00	CAP CHIP CER X7R 100NF
C468	2072-17105-00	CAP TANT CHIP 15UF 25V
C469	2072-17103-00	CAP TANT CHIP 4.7UF 10V
C470	2072-17105-00	CAP TANT CHIP 15UF 25V
C472	2072-17105-00	CAP TANT CHIP 15UF 25V
C473	2072-17105-00	CAP TANT CHIP 15UF 25V
C476	2072-17108-00	CAP ALU 220UF 35V
C477	2072-17105-00	CAP TANT CHIP 15UF 25V
C478	4017-20085-00	CAP CHIP CER X7R 100NF
C479	4017-20085-00	CAP CHIP CER X7R 100NF
C482	4017-20085-00	CAP CHIP CER X7R 100NF
C483	4017-20085-00	CAP CHIP CER X7R 100NF
C484	4017-20085-00	CAP CHIP CER X7R 100NF
C486	4017-20085-00	CAP CHIP CER X7R 100NF
C487	4017-25067-00	CAP CHIP CER COG 47PF
C488	4017-25409-00	CAP CER CHIP 10PF 500V
C489	4017-25409-00	CAP CER CHIP 10PF 500V
C490	4017-25074-00	CAP CHIP CER COG 180PF
C491	4017-25074-00	CAP CHIP CER COG 180PF
C492	4017-25433-00	CAP CER CHIP 1000PF 500
C493	4017-25425-00	CAP CER CHIP 220PF 500V
C495	4017-20102-00	CAP CHIP 10NF 200V
C497	2072-17106-00	CAP TANT CHIP 47UF 10V
C498	4017-20102-00	CAP CHIP 10NF 200V
C499	4017-20102-00	CAP CHIP 10NF 200V
C500	4017-20102-00	CAP CHIP 10NF 200V
C505	4017-20071-00	CAP CHIP CER X7R 10NF
C506	4017-20102-00	CAP CHIP 10NF 200V
C507	4017-80207-02	CAP TANT. 68UF 20V SMT
C508	4017-80207-02	CAP TANT. 68UF 20V SMT
C509	4017-80130-02	CHIPCAP. 220UF 16V
C511	4017-80204-02	CAP TANT. 33UF 25V SMT
C512	4017-80109-02	CAP CHIP TAN 100UF 16V
C513	4017-20085-00	CAP CHIP CER X7R 100NF
C514	4017-20085-00	CAP CHIP CER X7R 100NF
C515	4017-20085-00	CAP CHIP CER X7R 100NF
C517	4017-80130-02	CHIPCAP. 220UF 16V
C518	4017-25431-00	CAP CER CHIP 680PF 500V
C519	4017-20085-00	CAP CHIP CER X7R 100NF
C520	4017-20085-00	CAP CHIP CER X7R 100NF
C521	4017-20085-00	CAP CHIP CER X7R 100NF
CR4	4021-10114-35	SKY DIODE 50V HSMS2800
CR5	4021-10114-35	SKY DIODE 50V HSMS2800
CR6	4021-10114-35	SKY DIODE 50V HSMS2800
CR7	4021-10721-35	DIODE GEN PURP .1A 100V
CR8	4021-10721-35	DIODE GEN PURP .1A 100V
CR9	4021-10721-35	DIODE GEN PURP .1A 100V

Table 7-2. FTN6068A, High-Power Board, Parts List

Reference Designation	Part No.	Description
CR10	4021-10721-35	DIODE GEN PURP .1A 100V
CR11	4021-10721-35	DIODE GEN PURP .1A 100V
CR12	4021-10721-35	DIODE GEN PURP .1A 100V
CR13	4021-10721-35	DIODE GEN PURP .1A 100V
CR14	4021-10721-35	DIODE GEN PURP .1A 100V
CR15	4021-10721-35	DIODE GEN PURP .1A 100V
CR16	4021-10721-35	DIODE GEN PURP .1A 100V
CR17	4021-10721-35	DIODE GEN PURP .1A 100V
CR18	4021-10721-35	DIODE GEN PURP .1A 100V
CR19	4021-10721-35	DIODE GEN PURP .1A 100V
CR20	4021-10721-35	DIODE GEN PURP .1A 100V
CR21	4021-10721-35	DIODE GEN PURP .1A 100V
CR22	4021-10721-35	DIODE GEN PURP .1A 100V
CR23	4021-10721-35	DIODE GEN PURP .1A 100V
CR24	4021-10721-35	DIODE GEN PURP .1A 100V
CR25	4021-10721-35	DIODE GEN PURP .1A 100V
CR26	4021-10721-35	DIODE GEN PURP .1A 100V
CR27	4021-10282-35	RECT FAST-RECV 1A 600V
CR30	4021-10115-35	SKY DIODE 70V SOT-23
CR31	2072-21018-00	DIODE PIN SMD
CR32	2072-21018-00	DIODE PIN SMD
CR33	2072-21017-00	DIODE PIN SMD
CR34	2072-21017-00	DIODE PIN SMD
CR35	2072-21017-00	DIODE PIN SMD
CR36	2072-21017-00	DIODE PIN SMD
CR37	2072-21017-00	DIODE PIN SMD
CR38	2072-21017-00	DIODE PIN SMD
CR39	2072-21017-00	DIODE PIN SMD
CR40	2072-21017-00	DIODE PIN SMD
CR41	2072-21017-00	DIODE PIN SMD
CR42	2072-21017-00	DIODE PIN SMD
CR43	2072-21017-00	DIODE PIN SMD
CR44	2072-21017-00	DIODE PIN SMD
CR45	2072-21017-00	DIODE PIN SMD
CR46	2072-21017-00	DIODE PIN SMD
CR47	2072-21017-00	DIODE PIN SMD
CR48	2072-21017-00	DIODE PIN SMD
CR49	2072-21017-00	DIODE PIN SMD
CR50	2072-21017-00	DIODE PIN SMD
CR51	4021-10721-35	DIODE GEN PURP .1A 100V
CR54	2072-21018-00	DIODE PIN SMD
CR55	4021-10721-35	DIODE GEN PURP .1A 100V
CR56	2072-21018-00	DIODE PIN SMD
CR57	4021-10722-35	DIODE DUAL 70V COMM CAT
CR58	2072-21017-00	DIODE PIN SMD
CR59	2072-21017-00	DIODE PIN SMD
CR60	4021-10721-35	DIODE GEN PURP .1A 100V

Table 7-2. FTN6068A, High-Power Board, Parts List

Reference Designation	Part No.	Description
CR63	4021-10138-35	DIODE SCHOT 2X3A/60V
E1	2072-23002-00	ARRESTOR 350 VOLT
E2	2072-23001-00	ARRESTOR 90 VOLT
E3	2072-18001-00	INDUCTOR BEAD CHIP
J5	2072-33002-00	CONN D-TYPE 3 POUER CON
J8	2072-33005-00	HEADER 40 POS. 0.050" S
J10	2072-33016-00	RECEPTACLE COAX 002 PIN
J11	2072-33016-00	RECEPTACLE COAX 002 PIN
L22	4018-12323-00	INDUCTOR, CHIP 390NH 5
L23	4018-12323-00	INDUCTOR, CHIP 390NH 5
L24	4018-12206-00	CHIP IND 22UH 5% 1008
L25	4018-12206-00	CHIP IND 22UH 5% 1008
L26	4018-12206-00	CHIP IND 22UH 5% 1008
L27	4018-12206-00	CHIP IND 22UH 5% 1008
L33	2072-18008-00	CHIP IND 10000NH 5%
L41	2072-18008-00	CHIP IND 10000NH 5%
L42	2072-18008-00	CHIP IND 10000NH 5%
L49	2072-13008-00	COIL AIR WOUND INDUC 72
L50	2072-13008-00	COIL AIR WOUND INDUC 72
L53	4018-01340-00	RFC 100UH 10% SMT
L54	4018-01340-00	RFC 100UH 10% SMT
L55	4018-01340-00	RFC 100UH 10% SMT
L56	4018-01340-00	RFC 100UH 10% SMT
L57	4018-01340-00	RFC 100UH 10% SMT
L58	4018-01340-00	RFC 100UH 10% SMT
L60	4018-01340-00	RFC 100UH 10% SMT
L61	4018-01340-00	RFC 100UH 10% SMT
L62	4018-01340-00	RFC 100UH 10% SMT
L63	4018-01340-00	RFC 100UH 10% SMT
L64	4018-01340-00	RFC 100UH 10% SMT
L65	4018-01340-00	RFC 100UH 10% SMT
L66	4018-01340-00	RFC 100UH 10% SMT
L67	4018-01340-00	RFC 100UH 10% SMT
L68	4018-01340-00	RFC 100UH 10% SMT
L69	4018-01340-00	RFC 100UH 10% SMT
L70	4018-01340-00	RFC 100UH 10% SMT
L71	4018-01340-00	RFC 100UH 10% SMT
L72	4018-01340-00	RFC 100UH 10% SMT
L73	4018-01340-00	RFC 100UH 10% SMT
L74	4018-01340-00	RFC 100UH 10% SMT
L75	4018-01340-00	RFC 100UH 10% SMT
L76	4018-01340-00	RFC 100UH 10% SMT
L77	4018-01340-00	RFC 100UH 10% SMT
L78	4018-01340-00	RFC 100UH 10% SMT
L79	4018-01340-00	RFC 100UH 10% SMT
L80	4018-01340-00	RFC 100UH 10% SMT
L81	4018-01340-00	RFC 100UH 10% SMT

Table 7-2. FTN6068A, High-Power Board, Parts List

Reference Designation	Part No.	Description
L82	4018-01340-00	RFC 100UH 10% SMT
L83	4018-01340-00	RFC 100UH 10% SMT
L84	4018-01340-00	RFC 100UH 10% SMT
L85	4018-01340-00	RFC 100UH 10% SMT
L707	4018-12206-00	CHIP IND 22UH 5% 1008
L708	4018-12206-00	CHIP IND 22UH 5% 1008
L715	4018-01340-00	RFC 100UH 10% SMT
L717	2072-13002-00	RFCOIL 2.03UH 2408050
L721	2072-13001-00	RF CHOKE 220UH 2404626
L722	2072-13003-00	COIL RF 100UH 10%
L724	4018-01323-00	RFC 47UH 5%
L726	4018-01340-00	RFC 100UH 10% SMT
L727	4018-01340-00	RFC 100UH 10% SMT
L728	4018-02009-00	COIL HIGH CUR 22UH 3A
L729	4018-02001-00	COIL 10UH 1A
Q2	2072-21027-00	TSTR NPN SML SIG
Q3	2072-21027-00	TSTR NPN SML SIG
Q4	2072-21027-00	TSTR NPN SML SIG
Q5	2072-21027-00	TSTR NPN SML SIG
Q6	2072-21027-00	TSTR NPN SML SIG
Q7	4021-00341-35	PNP 40V .6A SW
Q8	4021-00341-35	PNP 40V .6A SW
Q10	4021-00342-35	NPN 40V .2A GEN PURP
Q11	4021-00342-35	NPN 40V .2A GEN PURP
Q12	4021-00340-35	NPN SW. 40V SOT-23
Q14	4021-00176-35	N-CH MOSFET LOW PWR
Q15	4021-00176-35	N-CH MOSFET LOW PWR
Q16	4021-00176-35	N-CH MOSFET LOW PWR
Q17	4021-00176-35	N-CH MOSFET LOW PWR
Q18	4021-00176-35	N-CH MOSFET LOW PWR
Q19	4021-00176-35	N-CH MOSFET LOW PWR
Q20	2072-21021-00	FET P-CH 30V 50A
Q22	2072-21022-00	P-CH PWR FET 60V 5A
Q23	2072-21020-00	TSTRN-CH 500V 2A
Q24	2072-21020-00	TSTRN-CH 500V 2A
Q25	2072-21020-00	TSTRN-CH 500V 2A
Q26	2072-21020-00	TSTRN-CH 500V 2A
Q27	2072-21020-00	TSTRN-CH 500V 2A
Q28	2072-21020-00	TSTRN-CH 500V 2A
Q29	2072-21020-00	TSTRN-CH 500V 2A
Q30	2072-21020-00	TSTRN-CH 500V 2A
Q31	2072-21020-00	TSTRN-CH 500V 2A
Q36	2072-21013-00	TSTR M9807
Q37	2072-21013-00	TSTR M9807
Q39	2072-21026-00	XSTR, RF SOT-23
Q40	4021-00176-35	N-CH MOSFET LOW PWR
Q41	4021-00176-35	N-CH MOSFET LOW PWR

Table 7-2. FTN6068A, High-Power Board, Parts List

Reference Designation	Part No.	Description
Q42	4021-00341-35	PNP 40V .6A SW
Q43	2072-21023-00	N-CH 60V 12A
Q44	2072-21023-00	N-CH 60V 12A
Q45	4021-00340-35	NPN SW. 40V SOT-23
Q46	4021-00340-35	NPN SW. 40V SOT-23
Q47	4021-00176-35	N-CH MOSFET LOW PWR
Q48	4021-00340-35	NPN SW. 40V SOT-23
Q49	4021-00340-35	NPN SW. 40V SOT-23
Q50	4021-00176-35	N-CH MOSFET LOW PWR
Q51	4021-00342-35	NPN 40V .2A GEN PURP
R102	4016-14752-10	RES CHIP 47.5K 1% 1/8W
R105	4016-43329-10	RES CHIP 33.2 1% 1W
R106	4016-43329-10	RES CHIP 33.2 1% 1W
R109	4016-43329-10	RES CHIP 33.2 1% 1W
R110	4016-43329-10	RES CHIP 33.2 1% 1W
R111	4016-42740-10	RES CHIP 274 1% 1W
R112	4016-43920-10	RES CHIP 392 1% 1W
R120	4016-40479-50	RES CHIP 4.7 5% 1W 251
R121	4016-40479-50	RES CHIP 4.7 5% 1W 251
R122	4016-40109-50	RES 2512 1.0 5% 1W
R123	4016-40109-50	RES 2512 1.0 5% 1W
R124	4016-40109-50	RES 2512 1.0 5% 1W
R125	4016-40109-50	RES 2512 1.0 5% 1W
R126	4016-91494-00	TERM. NTC 100K
R129	4016-15112-10	RES CHIP 51.1K 1% 1/8W
R130	4016-11002-10	RES CHIP 10.0K 1% 1/8W
R131	4016-11002-10	RES CHIP 10.0K 1% 1/8W
R132	4016-11001-10	RES CHIP 1.00K 1% 1/8W
R133	4016-14752-10	RES CHIP 47.5K 1% 1/8W
R134	4016-11009-10	RES CHIP 10.0 1% 1/8W
R135	4016-11009-10	RES CHIP 10.0 1% 1/8W
R137	4016-11001-10	RES CHIP 1.00K 1% 1/8W
R138	4016-11001-10	RES CHIP 1.00K 1% 1/8W
R139	4016-13320-10	RES CHIP 332 1% 1/8W
R140	4016-14751-10	RES CHIP 4.75K 1% 1/8W
R141	4016-15119-10	RES CHIP 51.1 1% 1/8W
R144	4016-11000-10	RES CHIP 100 1% 1/8W
R145	4016-11503-10	RES CHIP 150K 1% 1/8W
R146	4016-11503-10	RES CHIP 150K 1% 1/8W
R147	4016-11503-10	RES CHIP 150K 1% 1/8W
R148	4016-11503-10	RES CHIP 150K 1% 1/8W
R149	4016-11503-10	RES CHIP 150K 1% 1/8W
R150	4016-11503-10	RES CHIP 150K 1% 1/8W
R151	4016-11503-10	RES CHIP 150K 1% 1/8W
R152	4016-11503-10	RES CHIP 150K 1% 1/8W
R153	4016-11503-10	RES CHIP 150K 1% 1/8W
R154	4016-11503-10	RES CHIP 150K 1% 1/8W

Table 7-2. FTN6068A, High-Power Board, Parts List

Reference Designation	Part No.	Description
R155	4016-11503-10	RES CHIP 150K 1% 1/8W
R156	4016-11503-10	RES CHIP 150K 1% 1/8W
R157	4016-11503-10	RES CHIP 150K 1% 1/8W
R158	4016-11503-10	RES CHIP 150K 1% 1/8W
R159	4016-11503-10	RES CHIP 150K 1% 1/8W
R160	4016-11503-10	RES CHIP 150K 1% 1/8W
R161	4016-11503-10	RES CHIP 150K 1% 1/8W
R162	4016-11003-10	RES CHIP 100K 1% 1/8W
R163	4016-11003-10	RES CHIP 100K 1% 1/8W
R164	4016-11003-10	RES CHIP 100K 1% 1/8W
R165	4016-11003-10	RES CHIP 100K 1% 1/8W
R166	4016-11003-10	RES CHIP 100K 1% 1/8W
R167	4016-11003-10	RES CHIP 100K 1% 1/8W
R169	4016-15622-10	RES CHIP 56.2K 1% 1/8W
R170	4016-15112-10	RES CHIP 51.1K 1% 1/8W
R171	4016-15112-10	RES CHIP 51.1K 1% 1/8W
R172	4016-15112-10	RES CHIP 51.1K 1% 1/8W
R173	4016-15112-10	RES CHIP 51.1K 1% 1/8W
R174	4016-15112-10	RES CHIP 51.1K 1% 1/8W
R175	4016-15112-10	RES CHIP 51.1K 1% 1/8W
R176	4016-15112-10	RES CHIP 51.1K 1% 1/8W
R177	4016-15112-10	RES CHIP 51.1K 1% 1/8W
R178	4016-15112-10	RES CHIP 51.1K 1% 1/8W
R179	4016-15112-10	RES CHIP 51.1K 1% 1/8W
R180	4016-15112-10	RES CHIP 51.1K 1% 1/8W
R181	4016-15112-10	RES CHIP 51.1K 1% 1/8W
R182	4016-15112-10	RES CHIP 51.1K 1% 1/8W
R183	4016-15112-10	RES CHIP 51.1K 1% 1/8W
R184	4016-12212-10	RES CHIP 22.1K 1% 1/8W
R185	4016-14752-10	RES CHIP 47.5K 1% 1/8W
R186	4016-14752-10	RES CHIP 47.5K 1% 1/8W
R187	4016-14752-10	RES CHIP 47.5K 1% 1/8W
R189	4016-18251-10	-RES CHIP 8.25K 1% 1/8W
R190	4016-18251-10	RES CHIP 8.25K 1% 1/8W
R193	4016-12742-10	RES CHIP 27.4K 1% 1/8W
R195	4016-14751-10	RES CHIP 4.75K 1% 1/8W
R196	4016-12741-10	RES CHIP 2.74K 1% 1/8W
R197	4016-14751-10	RES CHIP 4.75K 1% 1/8W
R198	4016-14751-10	RES CHIP 4.75K 1% 1/8W
R199	4016-13321-10	-RES CHIP 3.32K 1% 1/8W
R200	4016-11501-10	RES CHIP 1.50K 1% 1/8W
R201	4016-11211-10	RES CHIP 1.21K 1% 1/8W
R202	4016-11211-10	RES CHIP 1.21K 1% 1/8W
R203	4016-11211-10	RES CHIP 1.21K 1% 1/8W
R204	4016-11211-10	RES CHIP 1.21K 1% 1/8W
R205	4016-11211-10	RES CHIP 1.21K 1% 1/8W
R206	4016-11211-10	RES CHIP 1.21K 1% 1/8W

Table 7-2. FTN6068A, High-Power Board, Parts List

Reference Designation	Part No.	Description
R207	4016-11211-10	RES CHIP 1.21K 1% 1/8W
R208	4016-11001-10	RES CHIP 1.00K 1% 1/8W
R209	4016-11001-10	RES CHIP 1.00K 1% 1/8W
R210	4016-21002-10	RES SMD 10.0K 1% 1/16W
R211	4016-21002-10	RES SMD 10.0K 1% 1/16W
R212	4016-21002-10	RES SMD 10.0K 1% 1/16W
R213	4016-21002-10	RES SMD 10.0K 1% 1/16W
R214	4016-21002-10	RES SMD 10.0K 1% 1/16W
R215	4016-21002-10	RES SMD 10.0K 1% 1/16W
R216	4016-21002-10	RES SMD 10.0K 1% 1/16W
R218	4016-12741-10	RES CHIP 2.74K 1% 1/8W
R220	4016-11001-10	RES CHIP 1.00K 1% 1/8W
R221	4016-11001-10	RES CHIP 1.00K 1% 1/8W
R224	4016-14750-10	RES CHIP 475 1% 1/8W
R225	4016-14750-10	RES CHIP 475 1% 1/8W
R226	4016-14750-10	RES CHIP 475 1% 1/8W
R227	4016-14750-10	RES CHIP 475 1% 1/8W
R228	4016-14750-10	RES CHIP 475 1% 1/8W
R229	4016-14750-10	RES CHIP 475 1% 1/8W
R235	4016-11820-10	RES CHIP 182 1% 1/8W
R236	4016-11500-10	RES CHIP 150 1% 1/8W
R237	4016-11500-10	RES CHIP 150 1% 1/8W
R238	4016-11300-10	RES CHIP 130 1% 1/8W
R239	4016-18259-10	RES CHIP 82.5 1% 1/8W
R241	4016-15119-10	RES CHIP 51.1 1% 1/8W
R242	4016-15119-10	RES CHIP 51.1 1% 1/8W
R243	4016-15119-10	RES CHIP 51.1 1% 1/8W
R244	4016-15119-10	RES CHIP 51.1 1% 1/8W
R247	4016-45119-10	RES 2512 51.1 1% 1W
R250	4016-11501-10	RES CHIP 1.50K 1% 1/8W
R251	4016-13929-10	RES CHIP 39.2 1% 1/8W
R252	4016-13929-10	RES CHIP 39.2 1% 1/8W
R253	4016-13929-10	RES CHIP 39.2 1% 1/8W
R254	4016-13929-10	RES CHIP 39.2 1% 1/8W
R257	4016-12749-10	RES SMD 27.4 1% 1/8W
R258	4016-12749-10	RES SMD 27.4 1% 1/8W
R259	4016-12749-10	RES SMD 27.4 1% 1/8W
R260	4016-12749-10	RES SMD 27.4 1% 1/8W
R261	4016-11000-10	RES CHIP 100 1% 1/8W
R262	4016-40479-50	RES CHIP 4.7 5% 1W 251
R263	4016-10399-50	RES CHIP 3.9 5% 1/8W
R264	4016-10279-50	RES CHIP 2.7 5% 1/8W
R265	4016-10279-50	RES CHIP 2.7 5% 1/8W
R266	4016-10109-50	RES CHIP 1 1/8W
R270	4016-15112-10	RES CHIP 51.1K 1% 1/8W
R271	4016-11001-10	RES CHIP 1.00K 1% 1/8W
R272	4016-15629-10	RES CHIP 56.2 1% 1/8W

Table 7-2. FTN6068A, High-Power Board, Parts List

Reference Designation	Part No.	Description
R273	4016-16810-10	RES CHIP 681 1% 1/8W
R274	4016-11500-10	RES CHIP 150 1% 1/8W
R275	4016-12749-10	RES SMD 27.4 1% 1/8W
R276	4016-15119-10	RES CHIP 51.1 1% 1/8W
R277	4016-12219-10	RES CHIP 22.1 1% 1/8W
R278	4016-15629-10	RES CHIP 56.2 1% 1/8W
R279	4016-15629-10	RES CHIP 56.2 1% 1/8W
R280	4016-15629-10	RES CHIP 56.2 1% 1/8W
R281	4016-15629-10	RES CHIP 56.2 1% 1/8W
R282	4016-18251-10	RES CHIP 8.25K 1% 1/8W
R283	4016-11001-10	RES CHIP 1.00K 1% 1/8W
R285	4016-14753-10	RES CHIP 475K 1% 1/8W
R286	4016-11820-10	RES CHIP 182 1% 1/8W
R287	4016-15112-10	RES CHIP 51.1K 1% 1/8W
R291	4016-13321-10	RES CHIP 3.32K 1% 1/8W
R292	4016-12742-10	RES CHIP 27.4K 1% 1/8W
R293	4016-15622-10	RES CHIP 56.2K 1% 1/8W
R294	4016-14753-10	RES CHIP 475K 1% 1/8W
R295	4016-12741-10	RES CHIP 2.74K 1% 1/8W
R296	4016-11002-10	RES CHIP 10.0K 1% 1/8W
R297	4016-15112-10	RES CHIP 51.1K 1% 1/8W
R298	4016-60102-00	TRIMPOT 10K OHM
R299	4016-60102-00	TRIMPOT 10K OHM
R300	4016-12430-10	RES CHIP 243 1% 1/8W
R301	4016-43329-10	RES CHIP 33.2 1% 1W
R302	4016-43329-10	RES CHIP 33.2 1% 1W
R303	4016-43329-10	RES CHIP 33.2 1% 1W
R304	4016-43329-10	RES CHIP 33.2 1% 1W
R305	4016-13320-10	RES CHIP 332 1% 1/8W
R306	4016-91493-00	TERM. NTC 470
R307	4016-11501-10	RES CHIP 1.50K 1% 1/8W
R308	4016-13650-10	RES CHIP 365 1% 1/8W
R309	4016-12430-10	RES CHIP 243 1% 1/8W
R310	4016-12430-10	RES CHIP 243 1% 1/8W
R312	4016-12741-10	RES CHIP 2.74K 1% 1/8W
R313	4016-18251-10	RES CHIP 8.25K 1% 1/8W
R314	4016-12219-10	RES CHIP 22.1 1% 1/8W
R315	4016-12741-10	RES CHIP 2.74K 1% 1/8W
R316	4016-91493-00	TERM. NTC 470
R317	4016-12741-10	RES CHIP 2.74K 1% 1/8W
R318	4016-16810-10	RES CHIP 681 1% 1/8W
R319	4016-12749-10	RES SMD 27.4 1% 1/8W
R320	4016-16810-10	RES CHIP 681 1% 1/8W
R321	4016-11001-10	RES CHIP 1.00K 1% 1/8W
R322	4016-12741-10	RES CHIP 2.74K 1% 1/8W
R324	4016-11211-10	RES CHIP 1.21K 1% 1/8W
R325	4016-11211-10	RES CHIP 1.21K 1% 1/8W

Table 7-2. FTN6068A, High-Power Board, Parts List

Reference Designation	Part No.	Description
R326	4016-11001-10	RES CHIP 1.00K 1% 1/8W
R327	4016-11001-10	RES CHIP 1.00K 1% 1/8W
R328	4016-18251-10	-RES CHIP 8.25K 1% 1/8W
R329	4016-12749-10	RES SMD 27.4 1% 1/8W
R330	4016-12749-10	RES SMD 27.4 1% 1/8W
R331	4016-12749-10	RES SMD 27.4 1% 1/8W
R332	4016-12749-10	RES SMD 27.4 1% 1/8W
R333	4016-11822-10	RES CHIP 18.2K 1% 1/8W
R334	4016-11211-10	RES CHIP 1.21K 1% 1/8W
R335	4016-11211-10	RES CHIP 1.21K 1% 1/8W
R336	4016-12741-10	RES CHIP 2.74K 1% 1/8W
R337	4016-12741-10	RES CHIP 2.74K 1% 1/8W
R338	4016-11501-10	RES CHIP 1.50K 1% 1/8W
R339	4016-11501-10	RES CHIP 1.50K 1% 1/8W
R340	4016-18251-10	-RES CHIP 8.25K 1% 1/8W
R341	4016-18251-10	-RES CHIP 8.25K 1% 1/8W
R342	4016-14751-10	RES CHIP 4.75K 1% 1/8W
R343	4016-14751-10	RES CHIP 4.75K 1% 1/8W
R345	4016-15112-10	RES CHIP 51.1K 1% 1/8W
R346	4016-11822-10	RES CHIP 18.2K 1% 1/8W
R347	4016-14752-10	RES CHIP 47.5K 1% 1/8W
R348	4016-11211-10	RES CHIP 1.21K 1% 1/8W
R349	4016-11211-10	RES CHIP 1.21K 1% 1/8W
R350	4016-11211-10	RES CHIP 1.21K 1% 1/8W
R351	4016-15112-10	RES CHIP 51.1K 1% 1/8W
R352	4016-11002-10	RES CHIP 10.0K 1% 1/8W
R355	4016-10000-10	RES CHIP 1/8W JMPR 0.0
R356	4016-21002-10	RES SMD 10.0K 1% 1/16W
R357	4016-21002-10	RES SMD 10.0K 1% 1/16W
R358	4016-22002-10	RES SMD 20.0K 1% 1/16W
R359	4016-11500-10	RES CHIP 150 1% 1/8W
R360	4016-10000-10	RES CHIP 1/8W JMPR 0.0
R361	4016-10000-10	RES CHIP 1/8W JMPR 0.0
R362	4016-10000-10	RES CHIP 1/8W JMPR 0.0
R363	4016-10000-10	RES CHIP 1/8W JMPR 0.0
R364	4016-10000-10	RES CHIP 1/8W JMPR 0.0
R365	4016-10000-10	RES CHIP 1/8W JMPR 0.0
R366	4016-10000-10	RES CHIP 1/8W JMPR 0.0
R367	4016-10000-10	RES CHIP 1/8W JMPR 0.0
R376	4016-21002-10	RES SMD 10.0K 1% 1/16W
R377	4016-21002-10	RES SMD 10.0K 1% 1/16W
R378	4016-21002-10	RES SMD 10.0K 1% 1/16W
R379	4016-21004-10	RES SMD 1.0M 1% 1/16W
R386	4016-21211-10	RES SMD 1.21K 1% 1/16W
R387	4016-21211-10	RES SMD 1.21K 1% 1/16W
R388	4016-21211-10	RES SMD 1.21K 1% 1/16W
R389	4016-21211-10	RES SMD 1.21K 1% 1/16W

Table 7-2. FTN6068A, High-Power Board, Parts List

Reference Designation	Part No.	Description
R390	4016-21211-10	RES SMD 1.21K 1% 1/16W
R391	4016-21211-10	RES SMD 1.21K 1% 1/16W
R392	4016-21211-10	RES SMD 1.21K 1% 1/16W
R393	4016-21211-10	RES SMD 1.21K 1% 1/16W
R394	4016-21211-10	RES SMD 1.21K 1% 1/16W
R395	4016-21211-10	RES SMD 1.21K 1% 1/16W
R396	4016-21211-10	RES SMD 1.21K 1% 1/16W
R397	4016-21211-10	RES SMD 1.21K 1% 1/16W
R398	4016-21211-10	RES SMD 1.21K 1% 1/16W
R399	4016-21211-10	RES SMD 1.21K 1% 1/16W
R400	4016-22492-10	RES SMD 24.9K 1% 1/16W
R401	4016-21004-10	RES SMD 1.0M 1% 1/16W
R402	4016-21004-10	RES SMD 1.0M 1% 1/16W
R403	4016-21004-10	RES SMD 1.0M 1% 1/16W
R404	4016-21004-10	RES SMD 1.0M 1% 1/16W
R405	4016-21004-10	RES SMD 1.0M 1% 1/16W
R406	4016-21004-10	RES SMD 1.0M 1% 1/16W
R407	4016-40109-50	RES 2512 1.0 5% 1W
SH1	2072-40050-00	SHLD 2683423K03
T3	2072-13004-00	RF POWER TRANSFORMER 2
T4	2072-13005-00	RF TRANSFORMER 2504641
T5	2072-13006-00	RF TRANSFORMER 2504641
T6	2072-13007-00	COIL TOROID 2583727K-0
T7	2072-13007-00	COIL TOROID 2583727K-0
U5	4021-60063-50	HCMOS SHF REG 74HC595
U6	2072-21043-00	QUADRUPLE NORTON OP .AM
U9	4021-20010-54	V-REG ADJ LP2951
U10	4021-20010-54	V-REG ADJ LP2951
U11	2072-21089-00	REG 8V 3A
U13	2112-21670-00	ADJ V-REG TO220
U14	2072-21107-00	IC,5V VOLT REG
U16	2388-21830-00	IC 14053 SOIC
U17	4021-20111-50	QUAD VOLT COMP LM2901
U18	4021-20111-50	QUAD VOLT COMP LM2901
VR1	2072-21030-00	DIODE REVERSE POLARITY
VR2	2072-21030-00	DIODE REVERSE POLARITY
VR3	4021-10471-35	ZENER 4.3V 5% 225MW SOT
VR5	4021-10423-35	ZENER 17V 5% 225MW

CONTROL HEAD BOARD
Model FTN6069A
Printed Circuit Board Details

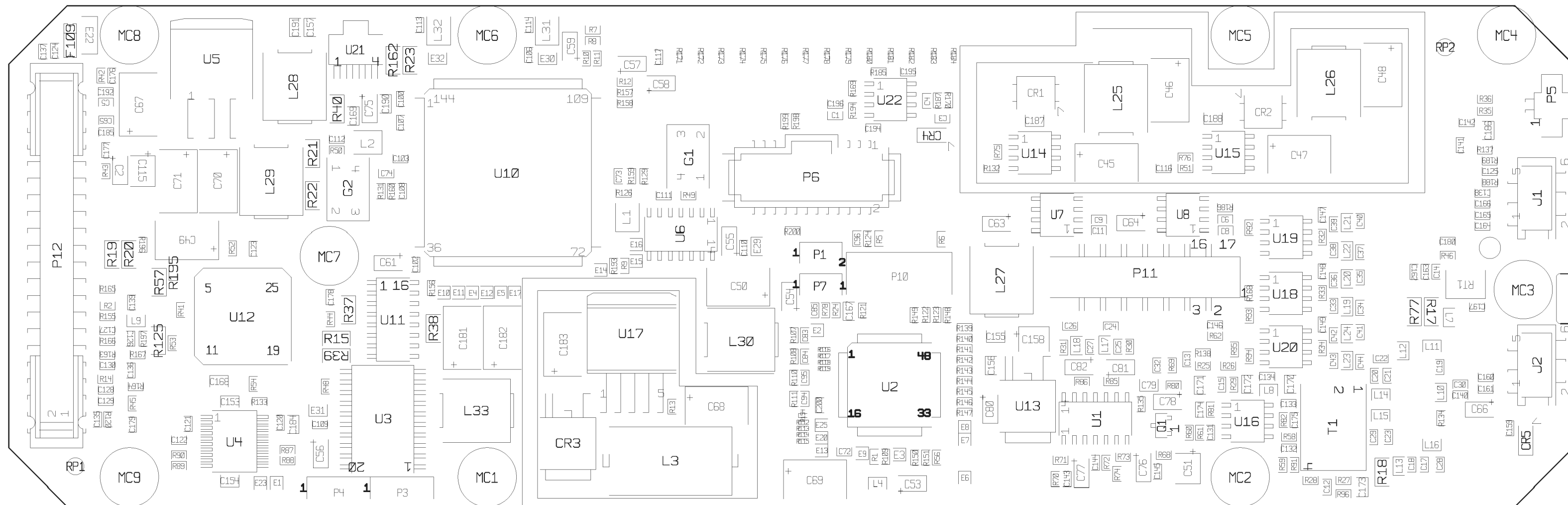

TOP VIEW

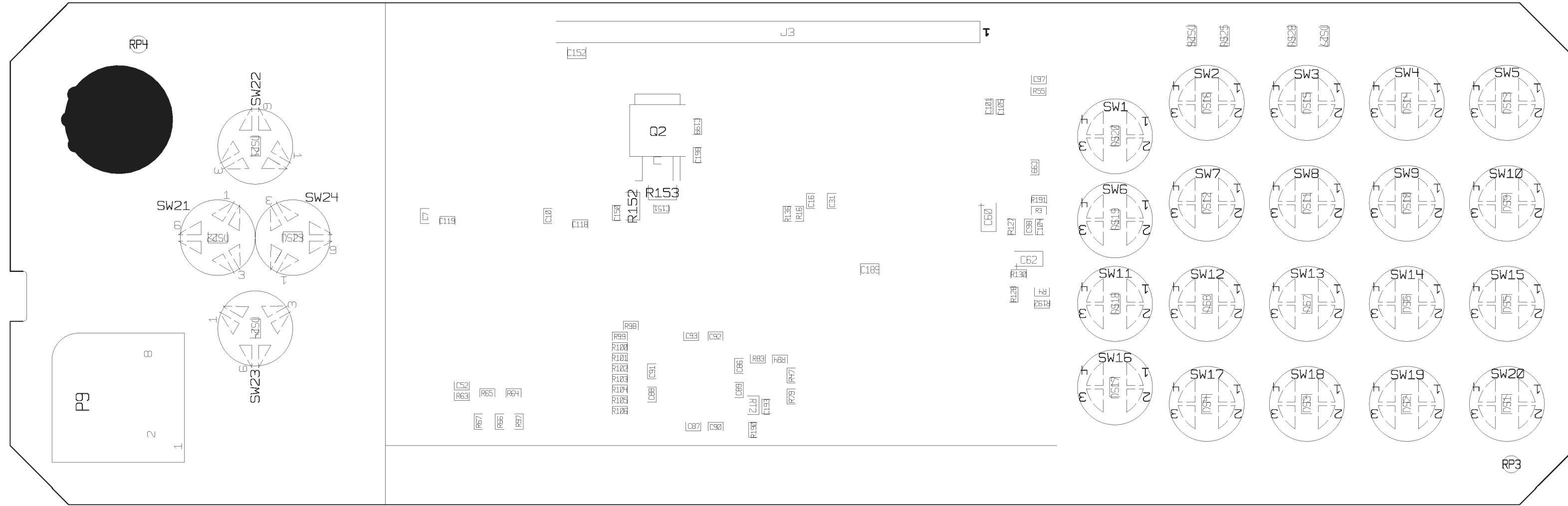

BOTTOM VIEW

CONTROL HEAD BOARD
Model FTN6069A
Schematic Diagram
Host Section - CPU

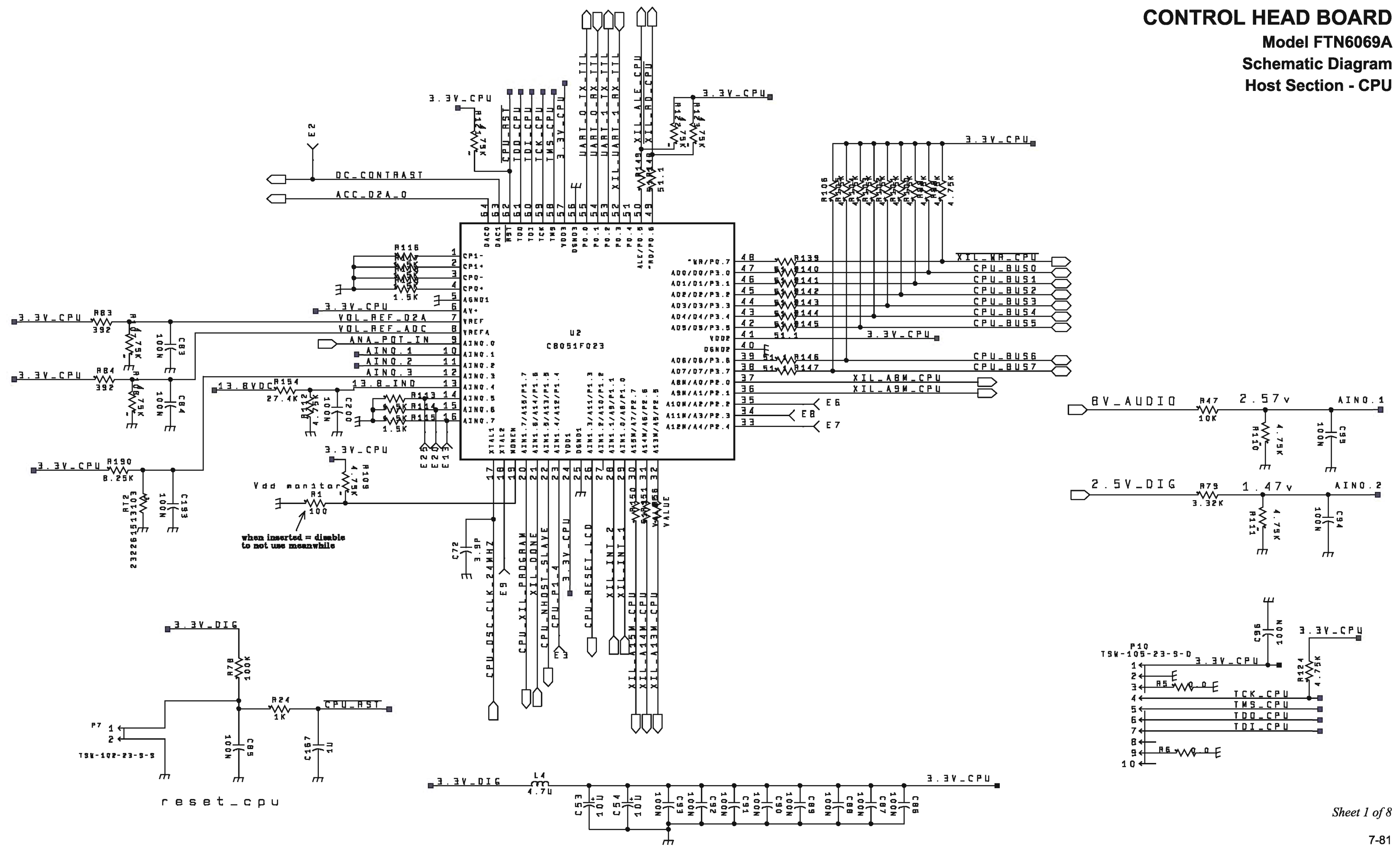

CONTROL HEAD BOARD

Model FTN6069A
Schematic Diagram
Host Section - FPGA

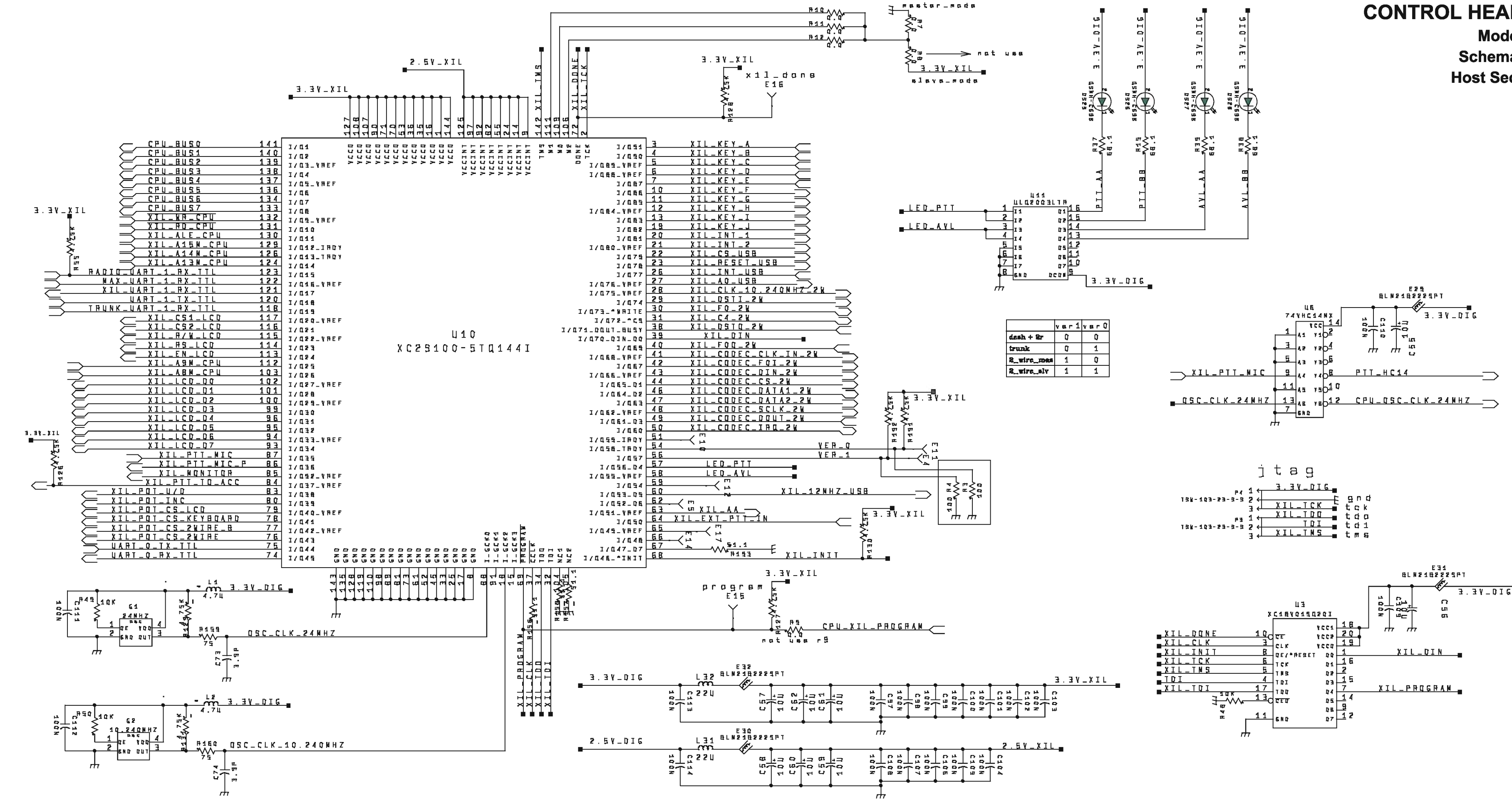

CONTROL HEAD BOARD
Model FTN6069A
Schematic Diagram
LCD Panel and Backlighting Section

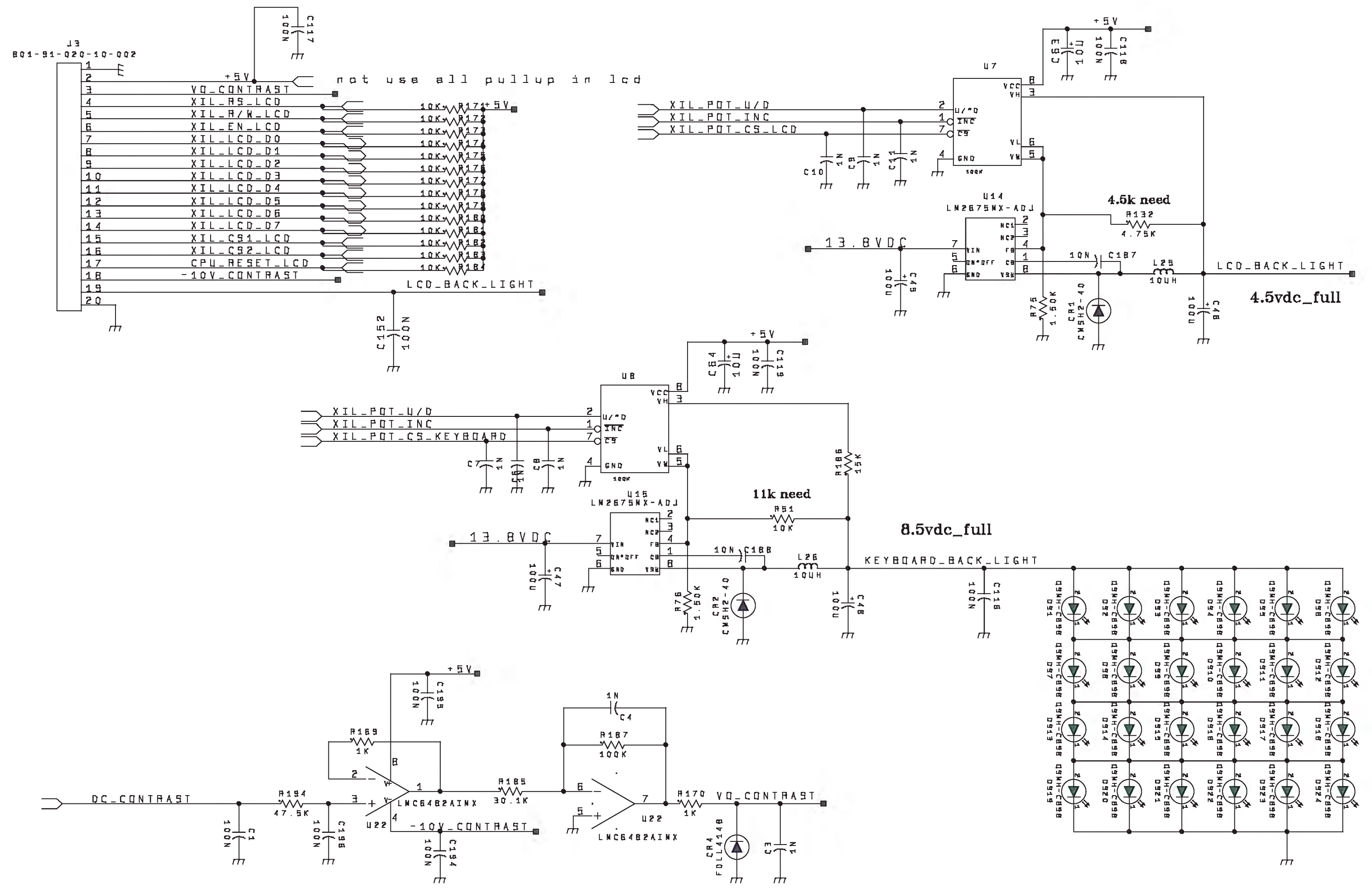

CONTROL HEAD BOARD
Model FTM6069A
Schematic Diagram
RS-232 and USB Interfaces Section

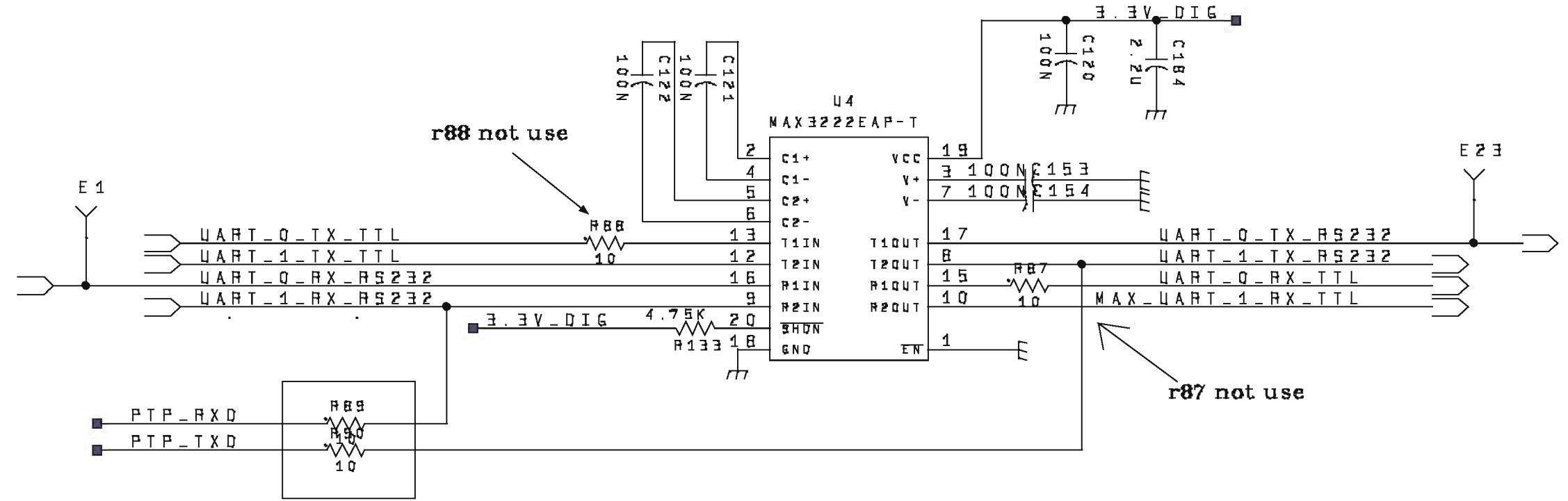

the rsistors connects only if use rss from mic connector in 2 wire

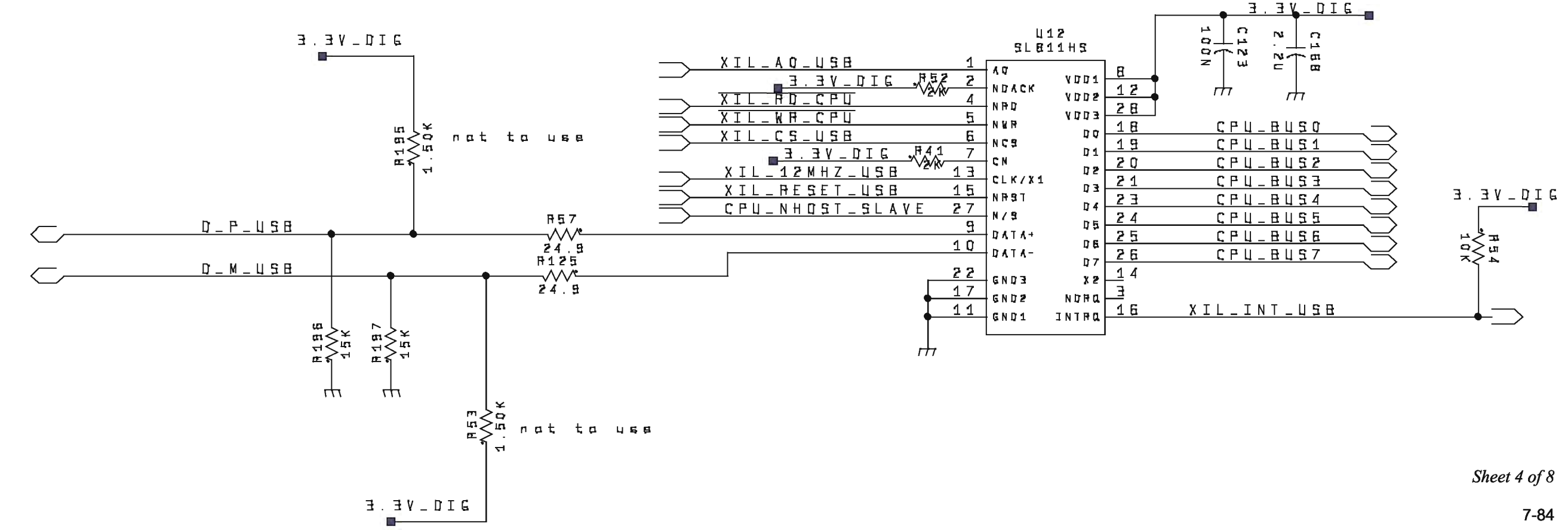

CONTROL HEAD BOARD
Model FTN6069A
Schematic Diagram
Power Supply Section

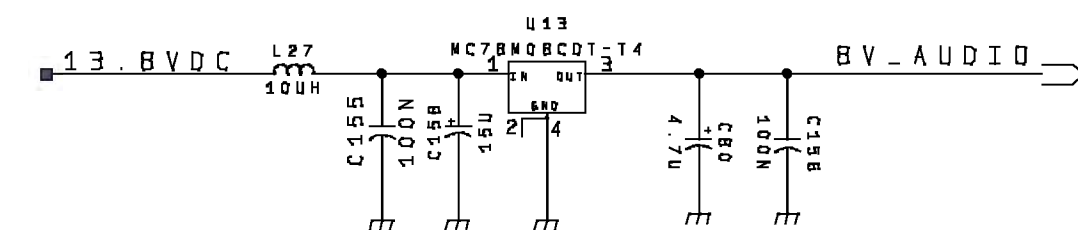
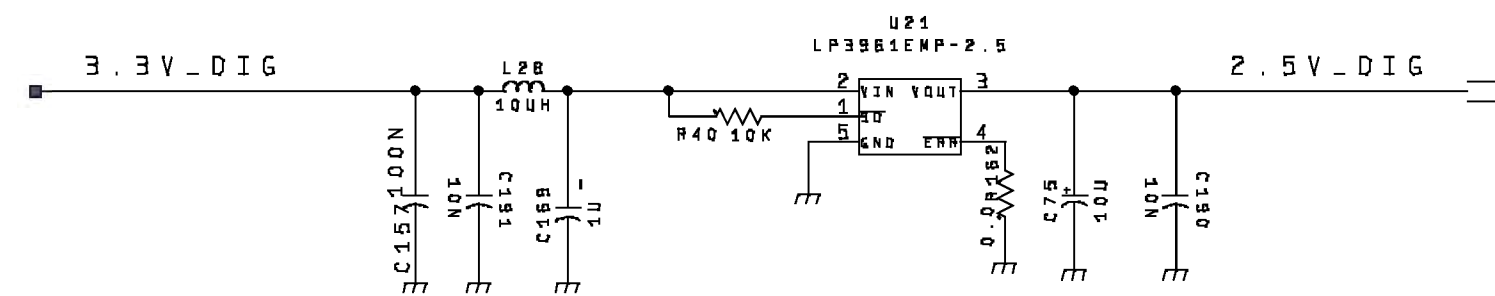
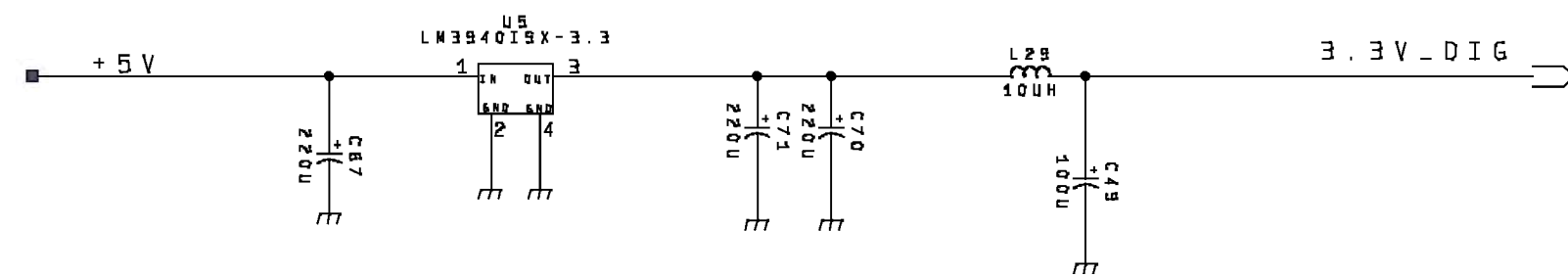
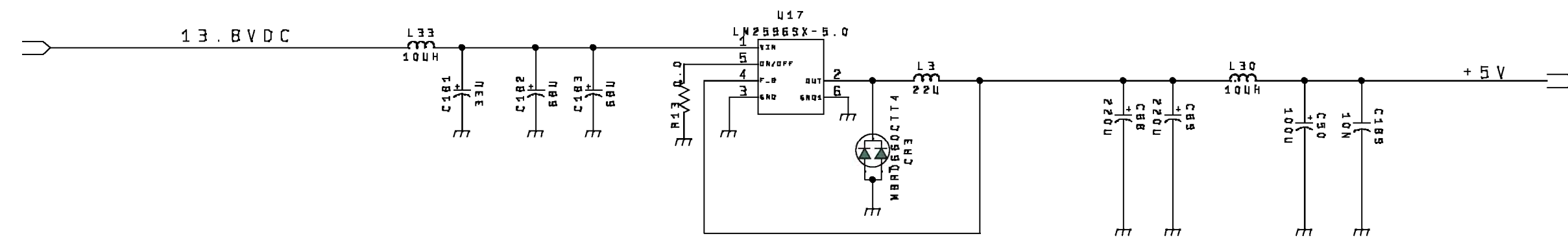

CONTROL HEAD BOARD
Model FTN6069A
Schematic Diagram
Audio and Accessories Interface Section

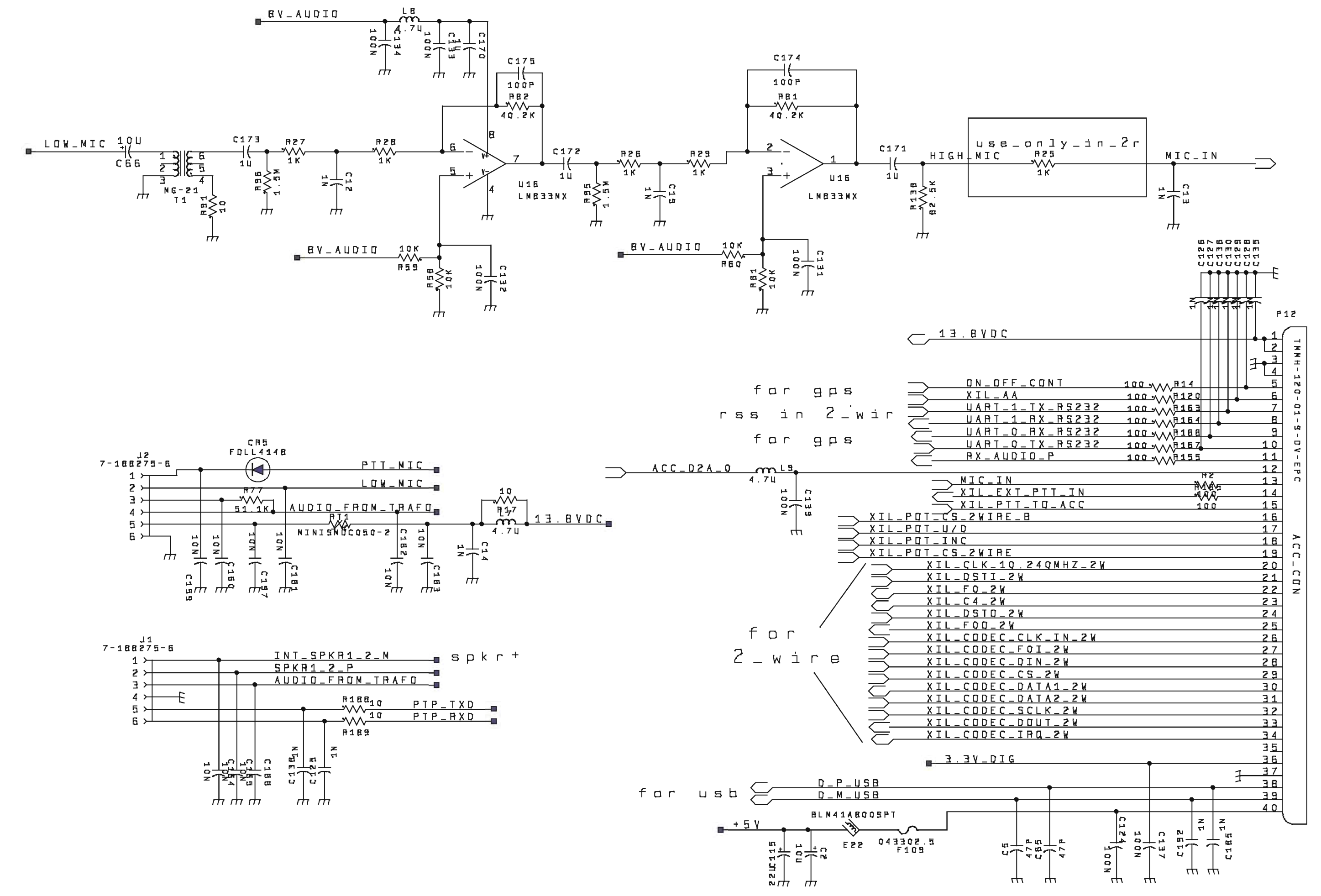

CONTROL HEAD BOARD
Model FTN6069A
Schematic Diagram
Keypad Section

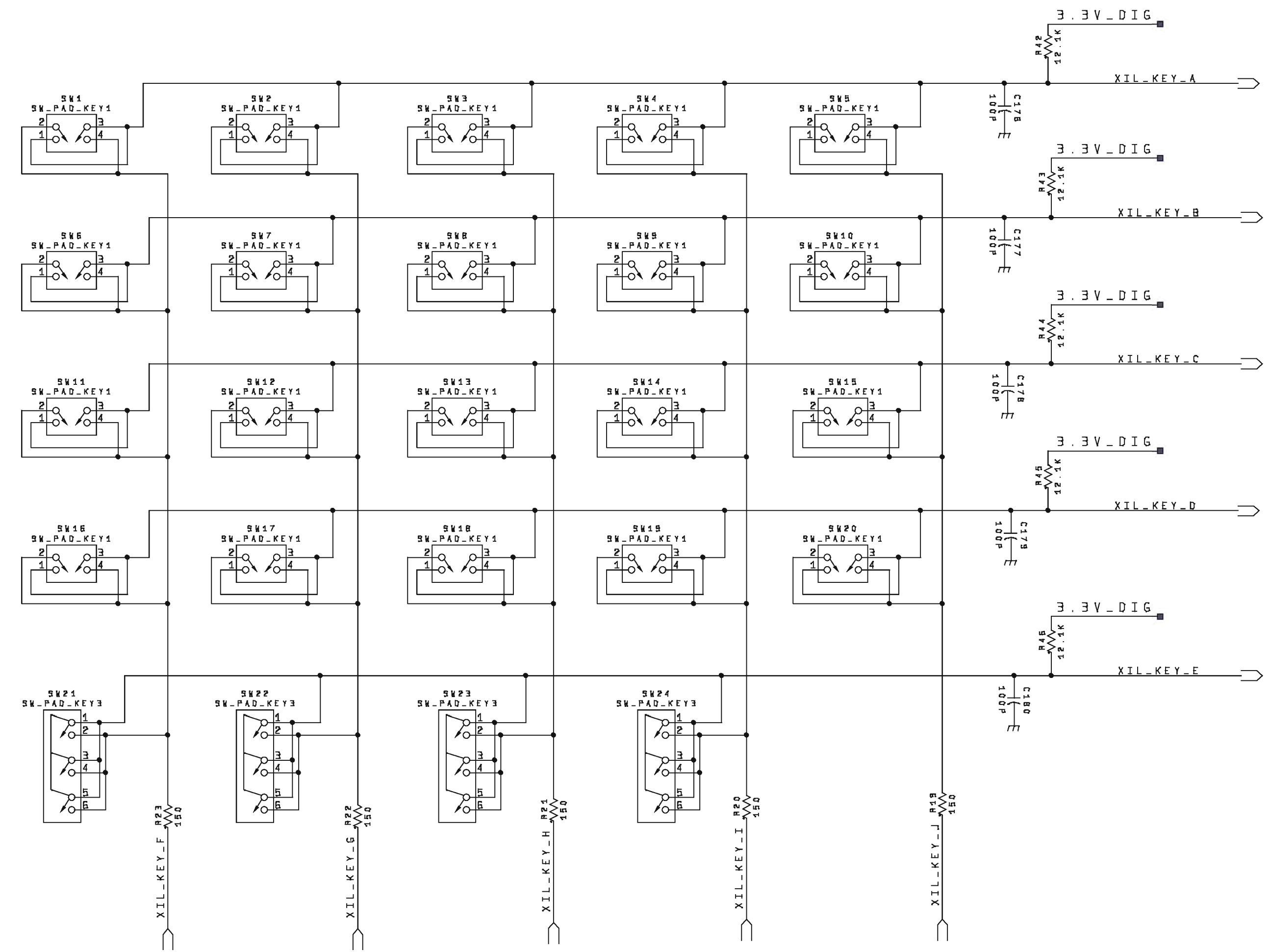

CONTROL HEAD BOARD
Model FTN6069A
Schematic Diagram
Interface to Trunk Unit Section

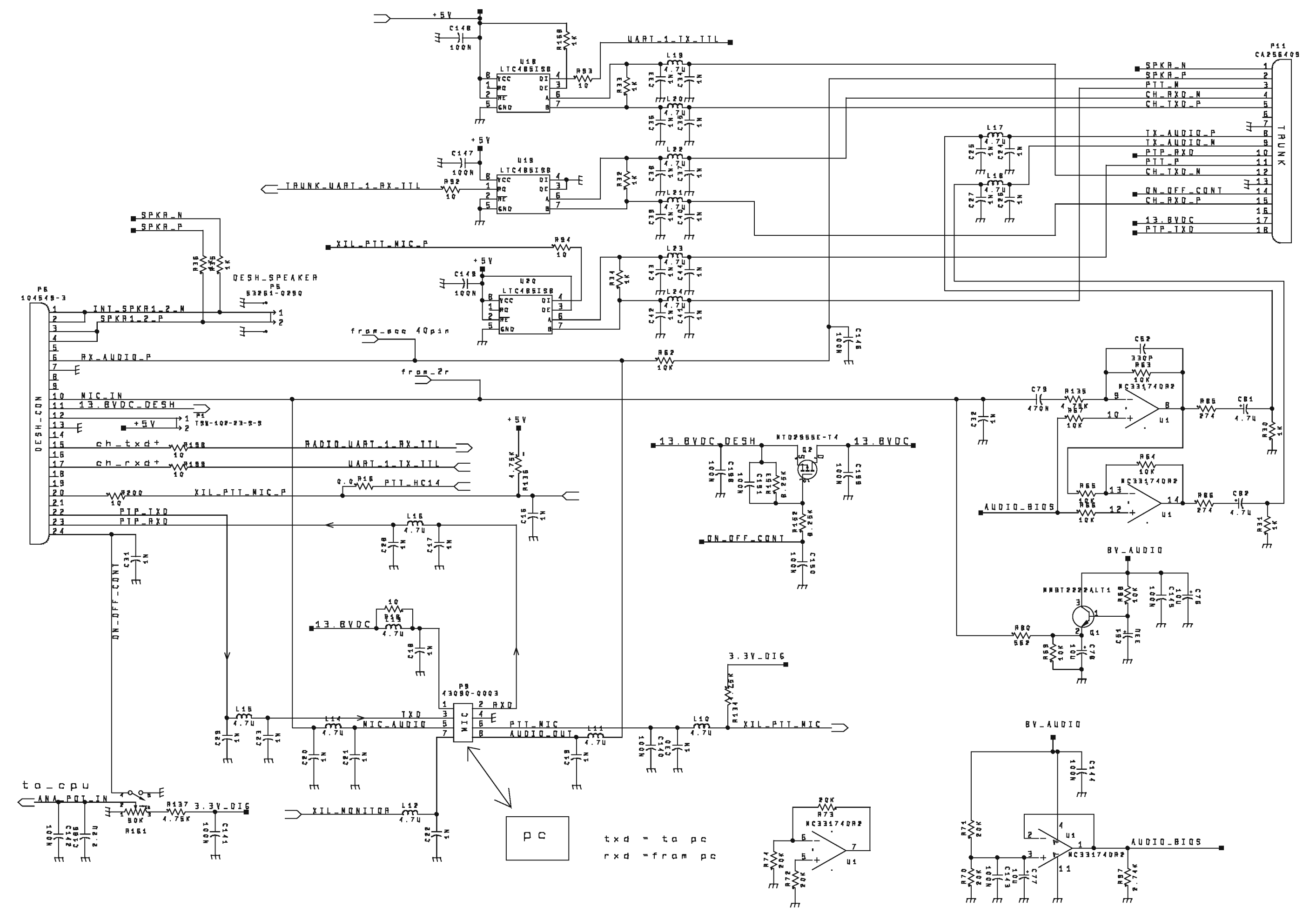

Table 7-3. FTN6069A, MICOM-3F, MICOM-3R, Control Head Board, Parts List

Reference Designation	Part No.	Description
	2072-21114-00	LCD FOR CONTROL HEAD MI
C1	4017-20284-00	CAP CHIP X7R 100NF 16V
C2	4017-80220-02	CAP CHIP TAN 10U 10V
C3	4017-25282-00	CAP CHIP CG 1NF 5%
C4	4017-25282-00	CAP CHIP CG 1NF 5%
C5	4017-25267-00	CAP CHIP 0603 NPO 47PF
C6	4017-25282-00	CAP CHIP CG 1NF 5%
C7	4017-25282-00	CAP CHIP CG 1NF 5%
C8	4017-25282-00	CAP CHIP CG 1NF 5%
C9	4017-25282-00	CAP CHIP CG 1NF 5%
C10	4017-25282-00	CAP CHIP CG 1NF 5%
C11	4017-25282-00	CAP CHIP CG 1NF 5%
C12	4017-25282-00	CAP CHIP CG 1NF 5%
C13	4017-25282-00	CAP CHIP CG 1NF 5%
C14	4017-25282-00	CAP CHIP CG 1NF 5%
C15	4017-25282-00	CAP CHIP CG 1NF 5%
C16	4017-25282-00	CAP CHIP CG 1NF 5%
C17	4017-25282-00	CAP CHIP CG 1NF 5%
C18	4017-25282-00	CAP CHIP CG 1NF 5%
C19	4017-25282-00	CAP CHIP CG 1NF 5%
C20	4017-25282-00	CAP CHIP CG 1NF 5%
C21	4017-25282-00	CAP CHIP CG 1NF 5%
C22	4017-25282-00	CAP CHIP CG 1NF 5%
C23	4017-25282-00	CAP CHIP CG 1NF 5%
C24	4017-25282-00	CAP CHIP CG 1NF 5%
C25	4017-25282-00	CAP CHIP CG 1NF 5%
C26	4017-25282-00	CAP CHIP CG 1NF 5%
C27	4017-25282-00	CAP CHIP CG 1NF 5%
C28	4017-25282-00	CAP CHIP CG 1NF 5%
C29	4017-25282-00	CAP CHIP CG 1NF 5%
C30	4017-25282-00	CAP CHIP CG 1NF 5%
C31	4017-25282-00	CAP CHIP CG 1NF 5%
C32	4017-25282-00	CAP CHIP CG 1NF 5%
C33	4017-25282-00	CAP CHIP CG 1NF 5%
C34	4017-25282-00	CAP CHIP CG 1NF 5%
C35	4017-25282-00	CAP CHIP CG 1NF 5%
C36	4017-25282-00	CAP CHIP CG 1NF 5%
C37	4017-25282-00	CAP CHIP CG 1NF 5%
C38	4017-25282-00	CAP CHIP CG 1NF 5%
C39	4017-25282-00	CAP CHIP CG 1NF 5%
C40	4017-25282-00	CAP CHIP CG 1NF 5%
C41	4017-25282-00	CAP CHIP CG 1NF 5%
C42	4017-25282-00	CAP CHIP CG 1NF 5%
C43	4017-25282-00	CAP CHIP CG 1NF 5%
C44	4017-25282-00	CAP CHIP CG 1NF 5%

Table 7-3. FTN6069A, MICOM-3F, MICOM-3R, Control Head Board, Parts List

Reference Designation	Part No.	Description
C45	4017-80109-02	CAP CHIP TAN 100UF 16V
C46	4017-80109-02	CAP CHIP TAN 100UF 16V
C47	4017-80109-02	CAP CHIP TAN 100UF 16V
C48	4017-80109-02	CAP CHIP TAN 100UF 16V
C49	4017-80109-02	CAP CHIP TAN 100UF 16V
C50	4017-80109-02	CAP CHIP TAN 100UF 16V
C51	4017-80127-02	CAP CHIP TAN 33UF 10V
C52	4017-25277-00	CAP CHIP CG 330PF 5%
C53	4017-80120-02	CHIPCAP. 10UF 6.3V
C54	4017-80120-02	CHIPCAP. 10UF 6.3V
C55	4017-80120-02	CHIPCAP. 10UF 6.3V
C56	4017-80120-02	CHIPCAP. 10UF 6.3V
C57	4017-80120-02	CHIPCAP. 10UF 6.3V
C58	4017-80120-02	CHIPCAP. 10UF 6.3V
C59	4017-80120-02	CHIPCAP. 10UF 6.3V
C60	4017-80120-02	CHIPCAP. 10UF 6.3V
C61	4017-80120-02	CHIPCAP. 10UF 6.3V
C62	4017-80120-02	CHIPCAP. 10UF 6.3V
C63	4017-80120-02	CHIPCAP. 10UF 6.3V
C64	4017-80120-02	CHIPCAP. 10UF 6.3V
C65	4017-25267-00	CAP CHIP 0603 NPO 47PF
C66	4017-80120-02	CHIPCAP. 10UF 6.3V
C67	4017-80130-02	CHIPCAP. 220UF 16V
C68	4017-80130-02	CHIPCAP. 220UF 16V
C69	4017-80130-02	CHIPCAP. 220UF 16V
C70	4017-80130-02	CHIPCAP. 220UF 16V
C71	4017-80130-02	CHIPCAP. 220UF 16V
C72	4017-25254-00	CAP 0603 COG 3.9P 50V
C73	4017-25254-00	CAP 0603 COG 3.9P 50V
C74	4017-25254-00	CAP 0603 COG 3.9P 50V
C75	4017-80220-02	CAP CHIP TAN 10U 10V
C76	4017-80220-02	CAP CHIP TAN 10U 10V
C77	4017-80220-02	CAP CHIP TAN 10U 10V
C78	4017-80220-02	CAP CHIP TAN 10U 10V
C79	4017-20201-00	CAP CHIP X7R 470N 16V
C80	4017-80102-02	CAP CHIP TAN 4.7UF 10V
C81	4017-80102-02	CAP CHIP TAN 4.7UF 10V
C82	4017-80102-02	CAP CHIP TAN 4.7UF 10V
C83	4017-20284-00	CAP CHIP X7R 100NF 16V
C84	4017-20284-00	CAP CHIP X7R 100NF 16V
C85	4017-20284-00	CAP CHIP X7R 100NF 16V
C86	4017-20284-00	CAP CHIP X7R 100NF 16V
C87	4017-20284-00	CAP CHIP X7R 100NF 16V
C88	4017-20284-00	CAP CHIP X7R 100NF 16V
C89	4017-20284-00	CAP CHIP X7R 100NF 16V
C90	4017-20284-00	CAP CHIP X7R 100NF 16V

Table 7-3. FTN6069A, MICOM-3F, MICOM-3R, Control Head Board, Parts List

Reference Designation	Part No.	Description
C91	4017-20284-00	CAP CHIP X7R 100NF 16V
C92	4017-20284-00	CAP CHIP X7R 100NF 16V
C93	4017-20284-00	CAP CHIP X7R 100NF 16V
C94	4017-20284-00	CAP CHIP X7R 100NF 16V
C95	4017-20284-00	CAP CHIP X7R 100NF 16V
C96	4017-20284-00	CAP CHIP X7R 100NF 16V
C97	4017-20284-00	CAP CHIP X7R 100NF 16V
C98	4017-20284-00	CAP CHIP X7R 100NF 16V
C99	4017-20284-00	CAP CHIP X7R 100NF 16V
C100	4017-20284-00	CAP CHIP X7R 100NF 16V
C101	4017-20284-00	CAP CHIP X7R 100NF 16V
C102	4017-20284-00	CAP CHIP X7R 100NF 16V
C103	4017-20284-00	CAP CHIP X7R 100NF 16V
C104	4017-20284-00	CAP CHIP X7R 100NF 16V
C105	4017-20284-00	CAP CHIP X7R 100NF 16V
C106	4017-20284-00	CAP CHIP X7R 100NF 16V
C107	4017-20284-00	CAP CHIP X7R 100NF 16V
C108	4017-20284-00	CAP CHIP X7R 100NF 16V
C109	4017-20284-00	CAP CHIP X7R 100NF 16V
C110	4017-20284-00	CAP CHIP X7R 100NF 16V
C111	4017-20284-00	CAP CHIP X7R 100NF 16V
C112	4017-20284-00	CAP CHIP X7R 100NF 16V
C113	4017-20284-00	CAP CHIP X7R 100NF 16V
C114	4017-20284-00	CAP CHIP X7R 100NF 16V
C115	4017-80128-02	CAP CHIP TAN 22UF 16V
C116	4017-20284-00	CAP CHIP X7R 100NF 16V
C117	4017-20284-00	CAP CHIP X7R 100NF 16V
C118	4017-20284-00	CAP CHIP X7R 100NF 16V
C119	4017-20284-00	CAP CHIP X7R 100NF 16V
C120	4017-20284-00	CAP CHIP X7R 100NF 16V
C121	4017-20284-00	CAP CHIP X7R 100NF 16V
C122	4017-20284-00	CAP CHIP X7R 100NF 16V
C123	4017-20284-00	CAP CHIP X7R 100NF 16V
C124	4017-20284-00	CAP CHIP X7R 100NF 16V
C125	4017-25282-00	CAP CHIP CG 1NF 5%
C126	4017-25282-00	CAP CHIP CG 1NF 5%
C127	4017-25282-00	CAP CHIP CG 1NF 5%
C128	4017-25282-00	CAP CHIP CG 1NF 5%
C129	4017-25282-00	CAP CHIP CG 1NF 5%
C130	4017-25282-00	CAP CHIP CG 1NF 5%
C131	4017-20284-00	CAP CHIP X7R 100NF 16V
C132	4017-20284-00	CAP CHIP X7R 100NF 16V
C133	4017-20284-00	CAP CHIP X7R 100NF 16V
C134	4017-20284-00	CAP CHIP X7R 100NF 16V
C135	4017-25282-00	CAP CHIP CG 1NF 5%
C136	4017-25282-00	CAP CHIP CG 1NF 5%

Table 7-3. FTN6069A, MICOM-3F, MICOM-3R, Control Head Board, Parts List

Reference Designation	Part No.	Description
C137	4017-20284-00	CAP CHIP X7R 100NF 16V
C138	4017-25282-00	CAP CHIP CG 1NF 5%
C139	4017-20284-00	CAP CHIP X7R 100NF 16V
C140	4017-20284-00	CAP CHIP X7R 100NF 16V
C141	4017-20284-00	CAP CHIP X7R 100NF 16V
C142	4017-20284-00	CAP CHIP X7R 100NF 16V
C143	4017-20284-00	CAP CHIP X7R 100NF 16V
C144	4017-20284-00	CAP CHIP X7R 100NF 16V
C145	4017-20284-00	CAP CHIP X7R 100NF 16V
C146	4017-20284-00	CAP CHIP X7R 100NF 16V
C147	4017-20284-00	CAP CHIP X7R 100NF 16V
C148	4017-20284-00	CAP CHIP X7R 100NF 16V
C149	4017-20284-00	CAP CHIP X7R 100NF 16V
C150	4017-20284-00	CAP CHIP X7R 100NF 16V
C151	4017-20284-00	CAP CHIP X7R 100NF 16V
C152	4017-20151-00	CAP CHIP X7R 100NF 25V
C153	4017-20151-00	CAP CHIP X7R 100NF 25V
C154	4017-20151-00	CAP CHIP X7R 100NF 25V
C155	4017-20151-00	CAP CHIP X7R 100NF 25V
C156	4017-20151-00	CAP CHIP X7R 100NF 25V
C157	4017-20151-00	CAP CHIP X7R 100NF 25V
C158	4017-80126-02	CAP CHIP TAN 15UF 16V
C159	4017-20271-00	CAP CHIP X7R 10NF 10%
C160	4017-20271-00	CAP CHIP X7R 10NF 10%
C161	4017-20271-00	CAP CHIP X7R 10NF 10%
C162	4017-20271-00	CAP CHIP X7R 10NF 10%
C163	4017-20271-00	CAP CHIP X7R 10NF 10%
C164	4017-20271-00	CAP CHIP X7R 10NF 10%
C165	4017-20271-00	CAP CHIP X7R 10NF 10%
C166	4017-20271-00	CAP CHIP X7R 10NF 10%
C167	4017-20161-00	CAP CHIP X7R 1UF 10V
C168	4017-20202-00	CAP CHIP X5R 2.2U 10V
C169	4017-20161-00	CAP CHIP X7R 1UF 10V
C170	4017-20161-00	CAP CHIP X7R 1UF 10V
C171	4017-20161-00	CAP CHIP X7R 1UF 10V
C172	4017-20161-00	CAP CHIP X7R 1UF 10V
C173	4017-20161-00	CAP CHIP X7R 1UF 10V
C174	4017-25271-00	CAP CHIP CG 100PF 5%
C175	4017-25271-00	CAP CHIP CG 100PF 5%
C176	4017-25271-00	CAP CHIP CG 100PF 5%
C177	4017-25271-00	CAP CHIP CG 100PF 5%
C178	4017-25271-00	CAP CHIP CG 100PF 5%
C179	4017-25271-00	CAP CHIP CG 100PF 5%
C180	4017-25271-00	CAP CHIP CG 100PF 5%
C181	4017-80204-02	CAP TANT. 33UF 25V SMT
C182	4017-80207-02	CAP TANT. 68UF 20V SMT

Table 7-3. FTN6069A, MICOM-3F, MICOM-3R, Control Head Board, Parts List

Reference Designation	Part No.	Description
C183	4017-80207-02	CAP TANT. 68UF 20V SMT
C184	4017-20202-00	CAP CHIP X5R 2.2U 10V
C185	4017-25282-00	CAP CHIP CG 1NF 5%
C186	4017-20202-00	CAP CHIP X5R 2.2U 10V
C187	4017-20071-00	CAP CHIP CER X7R 10NF
C188	4017-20071-00	CAP CHIP CER X7R 10NF
C189	4017-20071-00	CAP CHIP CER X7R 10NF
C190	4017-20071-00	CAP CHIP CER X7R 10NF
C191	4017-20071-00	CAP CHIP CER X7R 10NF
C192	4017-25282-00	CAP CHIP CG 1NF 5%
C193	4017-20284-00	CAP CHIP X7R 100NF 16V
C194	4017-20284-00	CAP CHIP X7R 100NF 16V
C195	4017-20284-00	CAP CHIP X7R 100NF 16V
C196	4017-20284-00	CAP CHIP X7R 100NF 16V
C197	4017-20271-00	CAP CHIP X7R 10NF 10%
C198	4017-20284-00	CAP CHIP X7R 100NF 16V
C199	4017-20284-00	CAP CHIP X7R 100NF 16V
C200	4017-20284-00	CAP CHIP X7R 100NF 16V
CR1	4021-10538-35	RECT SKY 2A 40V
CR2	4021-10538-35	RECT SKY 2A 40V
CR3	4021-10138-35	DIODE SCHOT 2X3A/60V
CR5	4021-10100-35	SW DIODE 70V FDLL4148
DS1	2072-21012-00	LED SMT GREEN
DS2	2072-21012-00	LED SMT GREEN
DS3	2072-21012-00	LED SMT GREEN
DS4	2072-21012-00	LED SMT GREEN
DS5	2072-21012-00	LED SMT GREEN
DS6	2072-21012-00	LED SMT GREEN
DS7	2072-21012-00	LED SMT GREEN
DS8	2072-21012-00	LED SMT GREEN
DS9	2072-21012-00	LED SMT GREEN
DS10	2072-21012-00	LED SMT GREEN
DS11	2072-21012-00	LED SMT GREEN
DS12	2072-21012-00	LED SMT GREEN
DS13	2072-21012-00	LED SMT GREEN
DS14	2072-21012-00	LED SMT GREEN
DS15	2072-21012-00	LED SMT GREEN
DS16	2072-21012-00	LED SMT GREEN
DS17	2072-21012-00	LED SMT GREEN
DS18	2072-21012-00	LED SMT GREEN
DS19	2072-21012-00	LED SMT GREEN
DS20	2072-21012-00	LED SMT GREEN
DS21	2072-21012-00	LED SMT GREEN
DS22	2072-21012-00	LED SMT GREEN
DS23	2072-21012-00	LED SMT GREEN
DS24	2072-21012-00	LED SMT GREEN

Table 7-3. FTN6069A, MICOM-3F, MICOM-3R, Control Head Board, Parts List

Reference Designation	Part No.	Description
DS25	2072-21010-00	LED SMT YEL
DS26	2072-21010-00	LED SMT YEL
DS27	2072-21011-00	LED SMT RED
DS28	2072-21011-00	LED SMT RED
E22	4018-60003-00	BEAD EMI
E29	4018-60007-00	BEAD EMI 2.2K
E30	4018-60007-00	BEAD EMI 2.2K
E31	4018-60007-00	BEAD EMI 2.2K
E32	4018-60007-00	BEAD EMI 2.2K
F109	4023-60020-00	FUSE VERY FAST 1206 2.5
G1	4024-10026-00	CRYSTAL OSC 24.00MHZ
J1	4033-60052-01	CONN. MICRO SMD 6S
J2	4033-60052-01	CONN. MICRO SMD 6S
J3	4033-50283-01	CONN. PCB. 20S
L1	4018-10017-00	COIL 4.7 UH 10% SM
L2	4018-10017-00	COIL 4.7 UH 10% SM
L3	4018-02009-00	COIL HIGH CUR 22UH 3A
L4	4018-12052-00	COIL FIX. 4.7UH
L7	4018-12052-00	COIL FIX. 4.7UH
L8	4018-12052-00	COIL FIX. 4.7UH
L9	4018-12052-00	COIL FIX. 4.7UH
L10	4018-12052-00	COIL FIX. 4.7UH
L11	4018-12052-00	COIL FIX. 4.7UH
L12	4018-12052-00	COIL FIX. 4.7UH
L13	4018-12052-00	COIL FIX. 4.7UH
L14	4018-12052-00	COIL FIX. 4.7UH
L15	4018-12052-00	COIL FIX. 4.7UH
L16	4018-12052-00	COIL FIX. 4.7UH
L17	4018-12052-00	COIL FIX. 4.7UH
L18	4018-12052-00	COIL FIX. 4.7UH
L19	4018-12052-00	COIL FIX. 4.7UH
L20	4018-12052-00	COIL FIX. 4.7UH
L21	4018-12052-00	COIL FIX. 4.7UH
L22	4018-12052-00	COIL FIX. 4.7UH
L23	4018-12052-00	COIL FIX. 4.7UH
L24	4018-12052-00	COIL FIX. 4.7UH
L25	4018-02001-00	COIL 10UH 1A
L26	4018-02001-00	COIL 10UH 1A
L27	4018-02001-00	COIL 10UH 1A
L28	4018-02001-00	COIL 10UH 1A
L29	4018-02001-00	COIL 10UH 1A
L30	4018-02001-00	COIL 10UH 1A
L31	4018-10016-00	COIL CHIP 22UH 10%
L32	4018-10016-00	COIL CHIP 22UH 10%
L33	4018-02001-00	COIL 10UH 1A
P3	4033-50213-01	STRIP SINGLE ROW 3 PIN

Table 7-3. FTN6069A, MICOM-3F, MICOM-3R, Control Head Board, Parts List

Reference Designation	Part No.	Description
P4	4033-50213-01	STRIP SINGLE ROW 3 PIN
P5	4033-51109-01	CONN. 2P 1.25mm SMT PLU
P6	4033-51201-01	HEADER 0.05" 2 Row 24P
P7	4033-50212-01	STRIP SINGLE ROW 2 PIN
P9	2072-33325-00	CONNECTOR MIC
P10	4033-50225-01	STRIP DOUBLE ROW 5PIN
P12	4033-51202-00	HEADER 2mm 40PIN SMT
Q2	4021-00218-35	P-CH MOSFET MTD2955
R2	4016-21000-10	RES SMD 100 1% 1/16W
R3	4016-21000-10	RES SMD 100 1% 1/16W
R4	4016-21000-10	RES SMD 100 1% 1/16W
R5	4016-20000-50	RES CHIP 0603 JUMPER
R6	4016-20000-50	RES CHIP 0603 JUMPER
R7	4016-20000-50	RES CHIP 0603 JUMPER
R10	4016-20000-50	RES CHIP 0603 JUMPER
R11	4016-20000-50	RES CHIP 0603 JUMPER
R12	4016-20000-50	RES CHIP 0603 JUMPER
R13	4016-20000-50	RES CHIP 0603 JUMPER
R14	4016-21000-10	RES SMD 100 1% 1/16W
R15	4016-16819-10	RES CHIP 68.1 1% 1/8W
R17	4016-11009-10	RES CHIP 10.0 1% 1/8W
R18	4016-11009-10	RES CHIP 10.0 1% 1/8W
R19	4016-11500-10	RES CHIP 150 1% 1/8W
R20	4016-11500-10	RES CHIP 150 1% 1/8W
R21	4016-11500-10	RES CHIP 150 1% 1/8W
R22	4016-11500-10	RES CHIP 150 1% 1/8W
R23	4016-11500-10	RES CHIP 150 1% 1/8W
R24	4016-21001-10	RES SMD 1.00K 1% 1/16W
R25	4016-21001-10	RES SMD 1.00K 1% 1/16W
R26	4016-21001-10	RES SMD 1.00K 1% 1/16W
R27	4016-21001-10	RES SMD 1.00K 1% 1/16W
R28	4016-21001-10	RES SMD 1.00K 1% 1/16W
R29	4016-21001-10	RES SMD 1.00K 1% 1/16W
R30	4016-21001-10	RES SMD 1.00K 1% 1/16W
R31	4016-21001-10	RES SMD 1.00K 1% 1/16W
R32	4016-21001-10	RES SMD 1.00K 1% 1/16W
R33	4016-21001-10	RES SMD 1.00K 1% 1/16W
R34	4016-21001-10	RES SMD 1.00K 1% 1/16W
R35	4016-21001-10	RES SMD 1.00K 1% 1/16W
R36	4016-21001-10	RES SMD 1.00K 1% 1/16W
R37	4016-16819-10	RES CHIP 68.1 1% 1/8W
R38	4016-16819-10	RES CHIP 68.1 1% 1/8W
R39	4016-16819-10	RES CHIP 68.1 1% 1/8W
R40	4016-11002-10	RES CHIP 10.0K 1% 1/8W
R41	4016-22001-10	RES SMD 2.0K 1% 1/16W
R42	4016-21212-10	RES SMD 12.1K 1% 1/16W

Table 7-3. FTN6069A, MICOM-3F, MICOM-3R, Control Head Board, Parts List

Reference Designation	Part No.	Description
R43	4016-21212-10	RES SMD 12.1K 1% 1/16W
R44	4016-21212-10	RES SMD 12.1K 1% 1/16W
R45	4016-21212-10	RES SMD 12.1K 1% 1/16W
R46	4016-21212-10	RES SMD 12.1K 1% 1/16W
R47	4016-21002-10	RES SMD 10.0K 1% 1/16W
R48	4016-21002-10	RES SMD 10.0K 1% 1/16W
R49	4016-21002-10	RES SMD 10.0K 1% 1/16W
R50	4016-21002-10	RES SMD 10.0K 1% 1/16W
R51	4016-21002-10	RES SMD 10.0K 1% 1/16W
R52	4016-22001-10	RES SMD 2.0K 1% 1/16W
R54	4016-21002-10	RES SMD 10.0K 1% 1/16W
R55	4016-24751-10	RES SMD 4.75K 1% 1/16W
R56	4016-25119-10	RES CHIP 0603 51.1 1%
R57	4016-12499-10	RES CHIP 24.9 1% 1/8W
R58	4016-21002-10	RES SMD 10.0K 1% 1/16W
R59	4016-21002-10	RES SMD 10.0K 1% 1/16W
R60	4016-21002-10	RES SMD 10.0K 1% 1/16W
R61	4016-21002-10	RES SMD 10.0K 1% 1/16W
R62	4016-21002-10	RES SMD 10.0K 1% 1/16W
R63	4016-21002-10	RES SMD 10.0K 1% 1/16W
R64	4016-21002-10	RES SMD 10.0K 1% 1/16W
R65	4016-21002-10	RES SMD 10.0K 1% 1/16W
R66	4016-21002-10	RES SMD 10.0K 1% 1/16W
R67	4016-21002-10	RES SMD 10.0K 1% 1/16W
R68	4016-21002-10	RES SMD 10.0K 1% 1/16W
R69	4016-21002-10	RES SMD 10.0K 1% 1/16W
R70	4016-22002-10	RES SMD 20.0K 1% 1/16W
R71	4016-22002-10	RES SMD 20.0K 1% 1/16W
R72	4016-22002-10	RES SMD 20.0K 1% 1/16W
R73	4016-22002-10	RES SMD 20.0K 1% 1/16W
R74	4016-22002-10	RES SMD 20.0K 1% 1/16W
R75	4016-21501-10	RES SMD 1.50K 1% 1/16W
R76	4016-21501-10	RES SMD 1.50K 1% 1/16W
R77	4016-15112-10	RES CHIP 51.1K 1% 1/8W
R78	4016-21003-10	RES SMD 100K 1% 1/16W
R79	4016-23321-10	RES SMD 3.32K 1% 1/16W
R80	4016-25620-10	RES CHIP 0603 562 1%
R81	4016-24022-10	RES SMD 40.2K 1% 1/16W
R82	4016-24022-10	RES SMD 40.2K 1% 1/16W
R83	4016-23920-10	RES SMD 392 1% 1/16W
R84	4016-23920-10	RES SMD 392 1% 1/16W
R85	4016-22740-10	RES SMD 274 1% 1/16W
R86	4016-22740-10	RES SMD 274 1% 1/16W
R87	4016-21009-10	RES CHIP 0603 10 1%
R88	4016-21009-10	RES CHIP 0603 10 1%
R91	4016-21009-10	RES CHIP 0603 10 1%

Table 7-3. FTN6069A, MICOM-3F, MICOM-3R, Control Head Board, Parts List

Reference Designation	Part No.	Description
R92	4016-21009-10	RES CHIP 0603 10 1%
R93	4016-21009-10	RES CHIP 0603 10 1%
R94	4016-21009-10	RES CHIP 0603 10 1%
R95	4016-20155-50	RES CHIP 1.5M 5% 1/16W
R96	4016-20155-50	RES CHIP 1.5M 5% 1/16W
R97	4016-22741-10	RES SMD 2.74K 1% 1/16W
R98	4016-24751-10	RES SMD 4.75K 1% 1/16W
R99	4016-24751-10	RES SMD 4.75K 1% 1/16W
R100	4016-24751-10	RES SMD 4.75K 1% 1/16W
R101	4016-24751-10	RES SMD 4.75K 1% 1/16W
R102	4016-24751-10	RES SMD 4.75K 1% 1/16W
R103	4016-24751-10	RES SMD 4.75K 1% 1/16W
R104	4016-24751-10	RES SMD 4.75K 1% 1/16W
R105	4016-24751-10	RES SMD 4.75K 1% 1/16W
R106	4016-24751-10	RES SMD 4.75K 1% 1/16W
R107	4016-24751-10	RES SMD 4.75K 1% 1/16W
R108	4016-24751-10	RES SMD 4.75K 1% 1/16W
R109	4016-24751-10	RES SMD 4.75K 1% 1/16W
R110	4016-24751-10	RES SMD 4.75K 1% 1/16W
R111	4016-24751-10	RES SMD 4.75K 1% 1/16W
R112	4016-54751-10	RES CHIP 0402 4.75K
R113	4016-51501-10	RES CHIP 0402 1.5K
R114	4016-51501-10	RES CHIP 0402 1.5K
R115	4016-51501-10	RES CHIP 0402 1.5K
R116	4016-51501-10	RES CHIP 0402 1.5K
R117	4016-51501-10	RES CHIP 0402 1.5K
R118	4016-51501-10	RES CHIP 0402 1.5K
R119	4016-51501-10	RES CHIP 0402 1.5K
R120	4016-21000-10	RES SMD 100 1% 1/16W
R121	4016-24751-10	RES SMD 4.75K 1% 1/16W
R122	4016-24751-10	RES SMD 4.75K 1% 1/16W
R123	4016-24751-10	RES SMD 4.75K 1% 1/16W
R124	4016-24751-10	RES SMD 4.75K 1% 1/16W
R125	4016-12499-10	RES CHIP 24.9 1% 1/8W
R126	4016-24751-10	RES SMD 4.75K 1% 1/16W
R127	4016-24751-10	RES SMD 4.75K 1% 1/16W
R128	4016-24751-10	RES SMD 4.75K 1% 1/16W
R129	4016-24751-10	RES SMD 4.75K 1% 1/16W
R130	4016-24751-10	RES SMD 4.75K 1% 1/16W
R131	4016-24751-10	RES SMD 4.75K 1% 1/16W
R132	4016-24751-10	RES SMD 4.75K 1% 1/16W
R133	4016-24751-10	RES SMD 4.75K 1% 1/16W
R134	4016-24751-10	RES SMD 4.75K 1% 1/16W
R135	4016-24751-10	RES SMD 4.75K 1% 1/16W
R136	4016-24751-10	RES SMD 4.75K 1% 1/16W
R137	4016-24751-10	RES SMD 4.75K 1% 1/16W

Table 7-3. FTN6069A, MICOM-3F, MICOM-3R, Control Head Board, Parts List

Reference Designation	Part No.	Description
R138	4016-28252-10	RES CHIP 0603 82.5K 1%
R139	4016-25119-10	RES CHIP 0603 51.1 1%
R140	4016-25119-10	RES CHIP 0603 51.1 1%
R141	4016-25119-10	RES CHIP 0603 51.1 1%
R142	4016-25119-10	RES CHIP 0603 51.1 1%
R143	4016-25119-10	RES CHIP 0603 51.1 1%
R144	4016-25119-10	RES CHIP 0603 51.1 1%
R145	4016-25119-10	RES CHIP 0603 51.1 1%
R146	4016-25119-10	RES CHIP 0603 51.1 1%
R147	4016-25119-10	RES CHIP 0603 51.1 1%
R148	4016-25119-10	RES CHIP 0603 51.1 1%
R149	4016-25119-10	RES CHIP 0603 51.1 1%
R150	4016-25119-10	RES CHIP 0603 51.1 1%
R151	4016-25119-10	RES CHIP 0603 51.1 1%
R152	4016-18251-10	-RES CHIP 8.25K 1% 1/8W
R153	4016-18251-10	-RES CHIP 8.25K 1% 1/8W
R154	4016-52742-10	RES CHIP 0402 27.4K 1%
R155	4016-21000-10	RES SMD 100 1% 1/16W
R156	4016-25119-10	RES CHIP 0603 51.1 1%
R157	4016-25119-10	RES CHIP 0603 51.1 1%
R158	4016-25119-10	RES CHIP 0603 51.1 1%
R159	4016-27509-10	RES CHIP 0603 75 1%
R160	4016-27509-10	RES CHIP 0603 75 1%
R161	4011-61001-00	POT VOL/ON/OFF
R162	4016-10000-10	RES CHIP 1/8W JMPR 0.0
R163	4016-21000-10	RES SMD 100 1% 1/16W
R164	4016-21000-10	RES SMD 100 1% 1/16W
R165	4016-21000-10	RES SMD 100 1% 1/16W
R166	4016-21000-10	RES SMD 100 1% 1/16W
R167	4016-21000-10	RES SMD 100 1% 1/16W
R168	4016-21001-10	RES SMD 1.00K 1% 1/16W
R169	4016-21001-10	RES SMD 1.00K 1% 1/16W
R170	4016-21001-10	RES SMD 1.00K 1% 1/16W
R185	4016-23012-10	RES CHIP 0603 30.1K 1%
R186	4016-21502-10	RES SMD 15.0K 1% 1/16W
R187	4016-21003-10	RES SMD 100K 1% 1/16W
R188	4016-21009-10	RES CHIP 0603 10 1%
R189	4016-21009-10	RES CHIP 0603 10 1%
R190	4016-28251-10	RES SMD 8.25K 1% 1/16W
R191	4016-24751-10	RES SMD 4.75K 1% 1/16W
R192	4016-24751-10	RES SMD 4.75K 1% 1/16W
R193	4016-25119-10	RES CHIP 0603 51.1 1%
R194	4016-24752-10	RES SMD 47.5K 1% 1/16W
R195	4016-21501-10	RES SMD 1.50K 1% 1/16W
R196	4016-21502-10	RES SMD 15.0K 1% 1/16W
R197	4016-21502-10	RES SMD 15.0K 1% 1/16W

Table 7-3. FTN6069A, MICOM-3F, MICOM-3R, Control Head Board, Parts List

Reference Designation	Part No.	Description
R198	4016-21009-10	RES CHIP 0603 10 1%
R199	4016-21009-10	RES CHIP 0603 10 1%
R200	4016-21009-10	RES CHIP 0603 10 1%
RT1	4023-60003-00	MULTIFUSE CHIP 500MA
RT2	4016-91103-20	TERM. NTC
T1	2072-13020-00	XFMR AF 600 TO 600
U2	4021-50040-64	MICRO 8051 FLASH RAM UA
U3	4021-60409-54	SERIAL PROM ISP JTAG 3.
U5	4021-20195-84	V-REG LDO 3.3V/1A
U6	4021-44014-54	INVERTER HEX SCHMIDT
U7	4021-74015-54	EE POT. X9C104S
U8	4021-74015-54	EE POT. X9C104S
U10	4021-39026-64	FPGA SPARTAN II
U11	4021-00039-35	NPN DARL ARRAY ULQ2003
U12	4021-50095-64	CONTR. USB HOST/SLAVE E
U13	4021-22114-50	+8V REG FIX 0.5A
U14	2112-21249-00	DC/DC/BUCK 1A SIMPLE SW
U15	2112-21249-00	DC/DC/BUCK 1A SIMPLE SW
U16	4021-20174-54	OP AMP AUDIO X2 L.NOIS
U17	4021-22007-54	SW.REG.+5V 3A
U21	4021-22101-74	LDO 2V5 0.8A EN+ERROR
U22	4021-20311-54	OP. AMP. DUAL R TO R

Table 7-4. FTN6070A, MICOM-3T Control Head Board, Parts List

Reference Designation	Part No.	Description
	2072-21114-00	LCD FOR CONTROL HEAD MI
C1	4017-20284-00	CAP CHIP X7R 100NF 16V
C2	4017-80220-02	CAP CHIP TAN 10U 10V
C3	4017-25282-00	CAP CHIP CG 1NF 5%
C4	4017-25282-00	CAP CHIP CG 1NF 5%
C5	4017-25267-00	CAP CHIP 0603 NPO 47PF
C6	4017-25282-00	CAP CHIP CG 1NF 5%
C7	4017-25282-00	CAP CHIP CG 1NF 5%
C8	4017-25282-00	CAP CHIP CG 1NF 5%
C9	4017-25282-00	CAP CHIP CG 1NF 5%
C10	4017-25282-00	CAP CHIP CG 1NF 5%
C11	4017-25282-00	CAP CHIP CG 1NF 5%
C12	4017-25282-00	CAP CHIP CG 1NF 5%
C13	4017-25282-00	CAP CHIP CG 1NF 5%
C14	4017-25282-00	CAP CHIP CG 1NF 5%
C15	4017-25282-00	CAP CHIP CG 1NF 5%
C16	4017-25282-00	CAP CHIP CG 1NF 5%
C17	4017-25282-00	CAP CHIP CG 1NF 5%
C18	4017-25282-00	CAP CHIP CG 1NF 5%
C19	4017-25282-00	CAP CHIP CG 1NF 5%
C20	4017-25282-00	CAP CHIP CG 1NF 5%
C21	4017-25282-00	CAP CHIP CG 1NF 5%
C22	4017-25282-00	CAP CHIP CG 1NF 5%
C23	4017-25282-00	CAP CHIP CG 1NF 5%
C24	4017-25282-00	CAP CHIP CG 1NF 5%
C25	4017-25282-00	CAP CHIP CG 1NF 5%
C26	4017-25282-00	CAP CHIP CG 1NF 5%
C27	4017-25282-00	CAP CHIP CG 1NF 5%
C28	4017-25282-00	CAP CHIP CG 1NF 5%
C29	4017-25282-00	CAP CHIP CG 1NF 5%
C30	4017-25282-00	CAP CHIP CG 1NF 5%
C31	4017-25282-00	CAP CHIP CG 1NF 5%
C32	4017-25282-00	CAP CHIP CG 1NF 5%
C33	4017-25282-00	CAP CHIP CG 1NF 5%
C34	4017-25282-00	CAP CHIP CG 1NF 5%
C35	4017-25282-00	CAP CHIP CG 1NF 5%
C36	4017-25282-00	CAP CHIP CG 1NF 5%
C37	4017-25282-00	CAP CHIP CG 1NF 5%
C38	4017-25282-00	CAP CHIP CG 1NF 5%
C39	4017-25282-00	CAP CHIP CG 1NF 5%
C40	4017-25282-00	CAP CHIP CG 1NF 5%
C41	4017-25282-00	CAP CHIP CG 1NF 5%
C42	4017-25282-00	CAP CHIP CG 1NF 5%
C43	4017-25282-00	CAP CHIP CG 1NF 5%
C44	4017-25282-00	CAP CHIP CG 1NF 5%
C45	4017-80109-02	CAP CHIP TAN 100UF 16V

Table 7-4. FTN6070A, MICOM-3T Control Head Board, Parts List

Reference Designation	Part No.	Description
C46	4017-80109-02	CAP CHIP TAN 100UF 16V
C47	4017-80109-02	CAP CHIP TAN 100UF 16V
C48	4017-80109-02	CAP CHIP TAN 100UF 16V
C49	4017-80109-02	CAP CHIP TAN 100UF 16V
C50	4017-80109-02	CAP CHIP TAN 100UF 16V
C51	4017-80127-02	CAP CHIP TAN 33UF 10V
C52	4017-25277-00	CAP CHIP CG 330PF 5%
C53	4017-80120-02	CHIP CAP. 10UF 6.3V
C54	4017-80120-02	CHIP CAP. 10UF 6.3V
C55	4017-80120-02	CHIP CAP. 10UF 6.3V
C56	4017-80120-02	CHIP CAP. 10UF 6.3V
C57	4017-80120-02	CHIP CAP. 10UF 6.3V
C58	4017-80120-02	CHIP CAP. 10UF 6.3V
C59	4017-80120-02	CHIP CAP. 10UF 6.3V
C60	4017-80120-02	CHIP CAP. 10UF 6.3V
C61	4017-80120-02	CHIP CAP. 10UF 6.3V
C62	4017-80120-02	CHIP CAP. 10UF 6.3V
C63	4017-80120-02	CHIP CAP. 10UF 6.3V
C64	4017-80120-02	CHIP CAP. 10UF 6.3V
C65	4017-25267-00	CAP CHIP 0603 NPO 47PF
C66	4017-80120-02	CHIP CAP. 10UF 6.3V
C67	4017-80130-02	CHIP CAP. 220UF 16V
C68	4017-80130-02	CHIP CAP. 220UF 16V
C69	4017-80130-02	CHIP CAP. 220UF 16V
C70	4017-80130-02	CHIP CAP. 220UF 16V
C71	4017-80130-02	CHIP CAP. 220UF 16V
C72	4017-25254-00	CAP 0603 COG 3.9P 50V
C73	4017-25254-00	CAP 0603 COG 3.9P 50V
C74	4017-25254-00	CAP 0603 COG 3.9P 50V
C75	4017-80220-02	CAP CHIP TAN 10U 10V
C76	4017-80220-02	CAP CHIP TAN 10U 10V
C77	4017-80220-02	CAP CHIP TAN 10U 10V
C78	4017-80220-02	CAP CHIP TAN 10U 10V
C79	4017-20201-00	CAP CHIP X7R 470N 16V
C80	4017-80102-02	CAP CHIP TAN 4.7UF 10V
C81	4017-80102-02	CAP CHIP TAN 4.7UF 10V
C82	4017-80102-02	CAP CHIP TAN 4.7UF 10V
C83	4017-20284-00	CAP CHIP X7R 100NF 16V
C84	4017-20284-00	CAP CHIP X7R 100NF 16V
C85	4017-20284-00	CAP CHIP X7R 100NF 16V
C86	4017-20284-00	CAP CHIP X7R 100NF 16V
C87	4017-20284-00	CAP CHIP X7R 100NF 16V
C88	4017-20284-00	CAP CHIP X7R 100NF 16V
C89	4017-20284-00	CAP CHIP X7R 100NF 16V
C90	4017-20284-00	CAP CHIP X7R 100NF 16V
C91	4017-20284-00	CAP CHIP X7R 100NF 16V
C92	4017-20284-00	CAP CHIP X7R 100NF 16V

Table 7-4. FTN6070A, MICOM-3T Control Head Board, Parts List

Reference Designation	Part No.	Description
C93	4017-20284-00	CAP CHIP X7R 100NF 16V
C94	4017-20284-00	CAP CHIP X7R 100NF 16V
C95	4017-20284-00	CAP CHIP X7R 100NF 16V
C96	4017-20284-00	CAP CHIP X7R 100NF 16V
C97	4017-20284-00	CAP CHIP X7R 100NF 16V
C98	4017-20284-00	CAP CHIP X7R 100NF 16V
C99	4017-20284-00	CAP CHIP X7R 100NF 16V
C100	4017-20284-00	CAP CHIP X7R 100NF 16V
C101	4017-20284-00	CAP CHIP X7R 100NF 16V
C102	4017-20284-00	CAP CHIP X7R 100NF 16V
C103	4017-20284-00	CAP CHIP X7R 100NF 16V
C104	4017-20284-00	CAP CHIP X7R 100NF 16V
C105	4017-20284-00	CAP CHIP X7R 100NF 16V
C106	4017-20284-00	CAP CHIP X7R 100NF 16V
C107	4017-20284-00	CAP CHIP X7R 100NF 16V
C108	4017-20284-00	CAP CHIP X7R 100NF 16V
C109	4017-20284-00	CAP CHIP X7R 100NF 16V
C110	4017-20284-00	CAP CHIP X7R 100NF 16V
C111	4017-20284-00	CAP CHIP X7R 100NF 16V
C112	4017-20284-00	CAP CHIP X7R 100NF 16V
C113	4017-20284-00	CAP CHIP X7R 100NF 16V
C114	4017-20284-00	CAP CHIP X7R 100NF 16V
C115	4017-80128-02	CAP CHIP TAN 22UF 16V
C116	4017-20284-00	CAP CHIP X7R 100NF 16V
C117	4017-20284-00	CAP CHIP X7R 100NF 16V
C118	4017-20284-00	CAP CHIP X7R 100NF 16V
C119	4017-20284-00	CAP CHIP X7R 100NF 16V
C120	4017-20284-00	CAP CHIP X7R 100NF 16V
C121	4017-20284-00	CAP CHIP X7R 100NF 16V
C122	4017-20284-00	CAP CHIP X7R 100NF 16V
C123	4017-20284-00	CAP CHIP X7R 100NF 16V
C124	4017-20284-00	CAP CHIP X7R 100NF 16V
C125	4017-25282-00	CAP CHIP CG 1NF 5%
C126	4017-25282-00	CAP CHIP CG 1NF 5%
C127	4017-25282-00	CAP CHIP CG 1NF 5%
C128	4017-25282-00	CAP CHIP CG 1NF 5%
C129	4017-25282-00	CAP CHIP CG 1NF 5%
C130	4017-25282-00	CAP CHIP CG 1NF 5%
C131	4017-20284-00	CAP CHIP X7R 100NF 16V
C132	4017-20284-00	CAP CHIP X7R 100NF 16V
C133	4017-20284-00	CAP CHIP X7R 100NF 16V
C134	4017-20284-00	CAP CHIP X7R 100NF 16V
C135	4017-25282-00	CAP CHIP CG 1NF 5%
C136	4017-25282-00	CAP CHIP CG 1NF 5%
C137	4017-20284-00	CAP CHIP X7R 100NF 16V
C138	4017-25282-00	CAP CHIP CG 1NF 5%
C139	4017-20284-00	CAP CHIP X7R 100NF 16V

Table 7-4. FTN6070A, MICOM-3T Control Head Board, Parts List

Reference Designation	Part No.	Description
C140	4017-20284-00	CAP CHIP X7R 100NF 16V
C141	4017-20284-00	CAP CHIP X7R 100NF 16V
C142	4017-20284-00	CAP CHIP X7R 100NF 16V
C143	4017-20284-00	CAP CHIP X7R 100NF 16V
C144	4017-20284-00	CAP CHIP X7R 100NF 16V
C145	4017-20284-00	CAP CHIP X7R 100NF 16V
C146	4017-20284-00	CAP CHIP X7R 100NF 16V
C147	4017-20284-00	CAP CHIP X7R 100NF 16V
C148	4017-20284-00	CAP CHIP X7R 100NF 16V
C149	4017-20284-00	CAP CHIP X7R 100NF 16V
C150	4017-20284-00	CAP CHIP X7R 100NF 16V
C151	4017-20284-00	CAP CHIP X7R 100NF 16V
C152	4017-20151-00	CAP CHIP X7R 100NF 25V
C153	4017-20151-00	CAP CHIP X7R 100NF 25V
C154	4017-20151-00	CAP CHIP X7R 100NF 25V
C155	4017-20151-00	CAP CHIP X7R 100NF 25V
C156	4017-20151-00	CAP CHIP X7R 100NF 25V
C157	4017-20151-00	CAP CHIP X7R 100NF 25V
C158	4017-80126-02	CAP CHIP TAN 15UF 16V
C159	4017-20271-00	CAP CHIP X7R 10NF 10%
C160	4017-20271-00	CAP CHIP X7R 10NF 10%
C161	4017-20271-00	CAP CHIP X7R 10NF 10%
C162	4017-20271-00	CAP CHIP X7R 10NF 10%
C163	4017-20271-00	CAP CHIP X7R 10NF 10%
C164	4017-20271-00	CAP CHIP X7R 10NF 10%
C165	4017-20271-00	CAP CHIP X7R 10NF 10%
C166	4017-20271-00	CAP CHIP X7R 10NF 10%
C167	4017-20161-00	CAP CHIP X7R 1UF 10V
C168	4017-20202-00	CAP CHIP X5R 2.2U 10V
C169	4017-20161-00	CAP CHIP X7R 1UF 10V
C170	4017-20161-00	CAP CHIP X7R 1UF 10V
C171	4017-20161-00	CAP CHIP X7R 1UF 10V
C172	4017-20161-00	CAP CHIP X7R 1UF 10V
C173	4017-20161-00	CAP CHIP X7R 1UF 10V
C174	4017-25271-00	CAP CHIP CG 100PF 5%
C175	4017-25271-00	CAP CHIP CG 100PF 5%
C176	4017-25271-00	CAP CHIP CG 100PF 5%
C177	4017-25271-00	CAP CHIP CG 100PF 5%
C178	4017-25271-00	CAP CHIP CG 100PF 5%
C179	4017-25271-00	CAP CHIP CG 100PF 5%
C180	4017-25271-00	CAP CHIP CG 100PF 5%
C181	4017-80204-02	CAP TANT. 33UF 25V SMT
C182	4017-80207-02	CAP TANT. 68UF 20V SMT
C183	4017-80207-02	CAP TANT. 68UF 20V SMT
C184	4017-20202-00	CAP CHIP X5R 2.2U 10V
C185	4017-25282-00	CAP CHIP CG 1NF 5%
C186	4017-20202-00	CAP CHIP X5R 2.2U 10V

Table 7-4. FTN6070A, MICOM-3T Control Head Board, Parts List

Reference Designation	Part No.	Description
C187	4017-20071-00	CAP CHIP CER X7R 10NF
C188	4017-20071-00	CAP CHIP CER X7R 10NF
C189	4017-20071-00	CAP CHIP CER X7R 10NF
C190	4017-20071-00	CAP CHIP CER X7R 10NF
C191	4017-20071-00	CAP CHIP CER X7R 10NF
C192	4017-25282-00	CAP CHIP CG 1NF 5%
C193	4017-20284-00	CAP CHIP X7R 100NF 16V
C194	4017-20284-00	CAP CHIP X7R 100NF 16V
C195	4017-20284-00	CAP CHIP X7R 100NF 16V
C196	4017-20284-00	CAP CHIP X7R 100NF 16V
C197	4017-20271-00	CAP CHIP X7R 10NF 10%
C198	4017-20284-00	CAP CHIP X7R 100NF 16V
C199	4017-20284-00	CAP CHIP X7R 100NF 16V
C200	4017-20284-00	CAP CHIP X7R 100NF 16V
CR1	4021-10538-35	RECT SKY 2A 40V
CR2	4021-10538-35	RECT SKY 2A 40V
CR3	4021-10138-35	DIODE SCHOT 2X3A/60V
CR5	4021-10100-35	SW DIODE 70V FDLL4148
DS1	2072-21012-00	LED SMT GREEN
DS2	2072-21012-00	LED SMT GREEN
DS3	2072-21012-00	LED SMT GREEN
DS4	2072-21012-00	LED SMT GREEN
DS5	2072-21012-00	LED SMT GREEN
DS6	2072-21012-00	LED SMT GREEN
DS7	2072-21012-00	LED SMT GREEN
DS8	2072-21012-00	LED SMT GREEN
DS9	2072-21012-00	LED SMT GREEN
DS10	2072-21012-00	LED SMT GREEN
DS11	2072-21012-00	LED SMT GREEN
DS12	2072-21012-00	LED SMT GREEN
DS13	2072-21012-00	LED SMT GREEN
DS14	2072-21012-00	LED SMT GREEN
DS15	2072-21012-00	LED SMT GREEN
DS16	2072-21012-00	LED SMT GREEN
DS17	2072-21012-00	LED SMT GREEN
DS18	2072-21012-00	LED SMT GREEN
DS19	2072-21012-00	LED SMT GREEN
DS20	2072-21012-00	LED SMT GREEN
DS21	2072-21012-00	LED SMT GREEN
DS22	2072-21012-00	LED SMT GREEN
DS23	2072-21012-00	LED SMT GREEN
DS24	2072-21012-00	LED SMT GREEN
DS25	2072-21010-00	LED SMT YEL
DS26	2072-21010-00	LED SMT YEL
DS27	2072-21011-00	LED SMT RED
DS28	2072-21011-00	LED SMT RED
E22	4018-60003-00	BEAD EMI

Table 7-4. FTN6070A, MICOM-3T Control Head Board, Parts List

Reference Designation	Part No.	Description
E29	4018-60007-00	BEAD EMI 2.2K
E30	4018-60007-00	BEAD EMI 2.2K
E31	4018-60007-00	BEAD EMI 2.2K
E32	4018-60007-00	BEAD EMI 2.2K
F109	4023-60020-00	FUSE VERY FAST 1206 2.5
G1	4024-10026-00	CRYSTAL OSC 24.00MHz
J3	4033-50283-01	CONN. PCB. 20S
L1	4018-10017-00	COIL 4.7 UH 10% SM
L2	4018-10017-00	COIL 4.7 UH 10% SM
L3	4018-02009-00	COIL HIGH CUR 22UH 3A
L4	4018-12052-00	COIL FIX. 4.7UH
L7	4018-12052-00	COIL FIX. 4.7UH
L8	4018-12052-00	COIL FIX. 4.7UH
L9	4018-12052-00	COIL FIX. 4.7UH
L10	4018-12052-00	COIL FIX. 4.7UH
L11	4018-12052-00	COIL FIX. 4.7UH
L12	4018-12052-00	COIL FIX. 4.7UH
L13	4018-12052-00	COIL FIX. 4.7UH
L14	4018-12052-00	COIL FIX. 4.7UH
L15	4018-12052-00	COIL FIX. 4.7UH
L16	4018-12052-00	COIL FIX. 4.7UH
L17	4018-12052-00	COIL FIX. 4.7UH
L18	4018-12052-00	COIL FIX. 4.7UH
L19	4018-12052-00	COIL FIX. 4.7UH
L20	4018-12052-00	COIL FIX. 4.7UH
L21	4018-12052-00	COIL FIX. 4.7UH
L22	4018-12052-00	COIL FIX. 4.7UH
L23	4018-12052-00	COIL FIX. 4.7UH
L24	4018-12052-00	COIL FIX. 4.7UH
L25	4018-02001-00	COIL 10UH 1A
L26	4018-02001-00	COIL 10UH 1A
L27	4018-02001-00	COIL 10UH 1A
L28	4018-02001-00	COIL 10UH 1A
L29	4018-02001-00	COIL 10UH 1A
L30	4018-02001-00	COIL 10UH 1A
L31	4018-10016-00	COIL CHIP 22UH 10%
L32	4018-10016-00	COIL CHIP 22UH 10%
L33	4018-02001-00	COIL 10UH 1A
P3	4033-50213-01	STRIP SINGLE ROW 3 PIN
P4	4033-50213-01	STRIP SINGLE ROW 3 PIN
P7	4033-50212-01	STRIP SINGLE ROW 2 PIN
P9	2072-33325-00	CONNECTOR MIC
P10	4033-50225-01	STRIP DOUBLE ROW 5PIN
P11	4033-51301-01	HEADER SMD VERTICAL 18P
P12	4033-51202-00	HEADER 2mm 40PIN SMT
Q1	4021-00202-35	NPN LO PWR MMBT2222A
R2	4016-21000-10	RES SMD 100 1% 1/16W

Table 7-4. FTN6070A, MICOM-3T Control Head Board, Parts List

Reference Designation	Part No.	Description
R4	4016-21000-10	RES SMD 100 1% 1/16W
R5	4016-20000-50	RES CHIP 0603 JUMPER
R6	4016-20000-50	RES CHIP 0603 JUMPER
R7	4016-20000-50	RES CHIP 0603 JUMPER
R10	4016-20000-50	RES CHIP 0603 JUMPER
R11	4016-20000-50	RES CHIP 0603 JUMPER
R12	4016-20000-50	RES CHIP 0603 JUMPER
R13	4016-20000-50	RES CHIP 0603 JUMPER
R14	4016-21000-10	RES SMD 100 1% 1/16W
R15	4016-16819-10	RES CHIP 68.1 1% 1/8W
R17	4016-11009-10	RES CHIP 10.0 1% 1/8W
R18	4016-11009-10	RES CHIP 10.0 1% 1/8W
R19	4016-11500-10	RES CHIP 150 1% 1/8W
R20	4016-11500-10	RES CHIP 150 1% 1/8W
R21	4016-11500-10	RES CHIP 150 1% 1/8W
R22	4016-11500-10	RES CHIP 150 1% 1/8W
R23	4016-11500-10	RES CHIP 150 1% 1/8W
R24	4016-21001-10	RES SMD 1.00K 1% 1/16W
R26	4016-21001-10	RES SMD 1.00K 1% 1/16W
R27	4016-21001-10	RES SMD 1.00K 1% 1/16W
R28	4016-21001-10	RES SMD 1.00K 1% 1/16W
R29	4016-21001-10	RES SMD 1.00K 1% 1/16W
R30	4016-21001-10	RES SMD 1.00K 1% 1/16W
R31	4016-21001-10	RES SMD 1.00K 1% 1/16W
R32	4016-21001-10	RES SMD 1.00K 1% 1/16W
R33	4016-21001-10	RES SMD 1.00K 1% 1/16W
R34	4016-21001-10	RES SMD 1.00K 1% 1/16W
R35	4016-21001-10	RES SMD 1.00K 1% 1/16W
R36	4016-21001-10	RES SMD 1.00K 1% 1/16W
R37	4016-16819-10	RES CHIP 68.1 1% 1/8W
R38	4016-11780-10	RES CHIP 178 1% 1/8W
R39	4016-11780-10	RES CHIP 178 1% 1/8W
R40	4016-11002-10	RES CHIP 10.0K 1% 1/8W
R41	4016-22001-10	RES SMD 2.0K 1% 1/16W
R42	4016-21212-10	RES SMD 12.1K 1% 1/16W
R43	4016-21212-10	RES SMD 12.1K 1% 1/16W
R44	4016-21212-10	RES SMD 12.1K 1% 1/16W
R45	4016-21212-10	RES SMD 12.1K 1% 1/16W
R46	4016-21212-10	RES SMD 12.1K 1% 1/16W
R47	4016-21002-10	RES SMD 10.0K 1% 1/16W
R48	4016-21002-10	RES SMD 10.0K 1% 1/16W
R49	4016-21002-10	RES SMD 10.0K 1% 1/16W
R50	4016-21002-10	RES SMD 10.0K 1% 1/16W
R51	4016-21002-10	RES SMD 10.0K 1% 1/16W
R52	4016-22001-10	RES SMD 2.0K 1% 1/16W
R54	4016-21002-10	RES SMD 10.0K 1% 1/16W
R55	4016-24751-10	RES SMD 4.75K 1% 1/16W

Table 7-4. FTN6070A, MICOM-3T Control Head Board, Parts List

Reference Designation	Part No.	Description
R56	4016-25119-10	RES CHIP 0603 51.1 1%
R57	4016-12499-10	RES CHIP 24.9 1% 1/8W
R58	4016-21002-10	RES SMD 10.0K 1% 1/16W
R59	4016-21002-10	RES SMD 10.0K 1% 1/16W
R60	4016-21002-10	RES SMD 10.0K 1% 1/16W
R61	4016-21002-10	RES SMD 10.0K 1% 1/16W
R62	4016-21002-10	RES SMD 10.0K 1% 1/16W
R63	4016-21002-10	RES SMD 10.0K 1% 1/16W
R64	4016-21002-10	RES SMD 10.0K 1% 1/16W
R65	4016-21002-10	RES SMD 10.0K 1% 1/16W
R66	4016-21002-10	RES SMD 10.0K 1% 1/16W
R67	4016-21002-10	RES SMD 10.0K 1% 1/16W
R68	4016-21002-10	RES SMD 10.0K 1% 1/16W
R69	4016-21002-10	RES SMD 10.0K 1% 1/16W
R70	4016-22002-10	RES SMD 20.0K 1% 1/16W
R71	4016-22002-10	RES SMD 20.0K 1% 1/16W
R72	4016-22002-10	RES SMD 20.0K 1% 1/16W
R73	4016-22002-10	RES SMD 20.0K 1% 1/16W
R74	4016-22002-10	RES SMD 20.0K 1% 1/16W
R75	4016-21501-10	RES SMD 1.50K 1% 1/16W
R76	4016-21501-10	RES SMD 1.50K 1% 1/16W
R77	4016-15112-10	RES CHIP 51.1K 1% 1/8W
R78	4016-21003-10	RES SMD 100K 1% 1/16W
R79	4016-23321-10	RES SMD 3.32K 1% 1/16W
R80	4016-25620-10	RES CHIP 0603 562 1%
R81	4016-24022-10	RES SMD 40.2K 1% 1/16W
R82	4016-24022-10	RES SMD 40.2K 1% 1/16W
R83	4016-23920-10	RES SMD 392 1% 1/16W
R84	4016-23920-10	RES SMD 392 1% 1/16W
R85	4016-22740-10	RES SMD 274 1% 1/16W
R86	4016-22740-10	RES SMD 274 1% 1/16W
R87	4016-21009-10	RES CHIP 0603 10 1%
R88	4016-21009-10	RES CHIP 0603 10 1%
R91	4016-21009-10	RES CHIP 0603 10 1%
R92	4016-21009-10	RES CHIP 0603 10 1%
R93	4016-21009-10	RES CHIP 0603 10 1%
R94	4016-21009-10	RES CHIP 0603 10 1%
R95	4016-20155-50	RES CHIP 1.5M 5% 1/16W
R96	4016-20155-50	RES CHIP 1.5M 5% 1/16W
R97	4016-22741-10	RES SMD 2.74K 1% 1/16W
R98	4016-24751-10	RES SMD 4.75K 1% 1/16W
R99	4016-24751-10	RES SMD 4.75K 1% 1/16W
R100	4016-24751-10	RES SMD 4.75K 1% 1/16W
R101	4016-24751-10	RES SMD 4.75K 1% 1/16W
R102	4016-24751-10	RES SMD 4.75K 1% 1/16W
R103	4016-24751-10	RES SMD 4.75K 1% 1/16W
R104	4016-24751-10	RES SMD 4.75K 1% 1/16W

Table 7-4. FTN6070A, MICOM-3T Control Head Board, Parts List

Reference Designation	Part No.	Description
R105	4016-24751-10	RES SMD 4.75K 1% 1/16W
R106	4016-24751-10	RES SMD 4.75K 1% 1/16W
R107	4016-24751-10	RES SMD 4.75K 1% 1/16W
R108	4016-24751-10	RES SMD 4.75K 1% 1/16W
R109	4016-24751-10	RES SMD 4.75K 1% 1/16W
R110	4016-24751-10	RES SMD 4.75K 1% 1/16W
R111	4016-24751-10	RES SMD 4.75K 1% 1/16W
R112	4016-54751-10	RES CHIP 0402 4.75K
R113	4016-51501-10	RES CHIP 0402 1.5K
R114	4016-51501-10	RES CHIP 0402 1.5K
R115	4016-51501-10	RES CHIP 0402 1.5K
R116	4016-51501-10	RES CHIP 0402 1.5K
R117	4016-51501-10	RES CHIP 0402 1.5K
R118	4016-51501-10	RES CHIP 0402 1.5K
R119	4016-51501-10	RES CHIP 0402 1.5K
R120	4016-21000-10	RES SMD 100 1% 1/16W
R121	4016-24751-10	RES SMD 4.75K 1% 1/16W
R122	4016-24751-10	RES SMD 4.75K 1% 1/16W
R123	4016-24751-10	RES SMD 4.75K 1% 1/16W
R124	4016-24751-10	RES SMD 4.75K 1% 1/16W
R125	4016-12499-10	RES CHIP 24.9 1% 1/8W
R126	4016-24751-10	RES SMD 4.75K 1% 1/16W
R127	4016-24751-10	RES SMD 4.75K 1% 1/16W
R128	4016-24751-10	RES SMD 4.75K 1% 1/16W
R129	4016-24751-10	RES SMD 4.75K 1% 1/16W
R130	4016-24751-10	RES SMD 4.75K 1% 1/16W
R131	4016-24751-10	RES SMD 4.75K 1% 1/16W
R132	4016-24751-10	RES SMD 4.75K 1% 1/16W
R133	4016-24751-10	RES SMD 4.75K 1% 1/16W
R134	4016-24751-10	RES SMD 4.75K 1% 1/16W
R135	4016-24751-10	RES SMD 4.75K 1% 1/16W
R136	4016-24751-10	RES SMD 4.75K 1% 1/16W
R137	4016-24751-10	RES SMD 4.75K 1% 1/16W
R138	4016-28252-10	RES CHIP 0603 82.5K 1%
R139	4016-25119-10	RES CHIP 0603 51.1 1%
R140	4016-25119-10	RES CHIP 0603 51.1 1%
R141	4016-25119-10	RES CHIP 0603 51.1 1%
R142	4016-25119-10	RES CHIP 0603 51.1 1%
R143	4016-25119-10	RES CHIP 0603 51.1 1%
R144	4016-25119-10	RES CHIP 0603 51.1 1%
R145	4016-25119-10	RES CHIP 0603 51.1 1%
R146	4016-25119-10	RES CHIP 0603 51.1 1%
R147	4016-25119-10	RES CHIP 0603 51.1 1%
R148	4016-25119-10	RES CHIP 0603 51.1 1%
R149	4016-25119-10	RES CHIP 0603 51.1 1%
R150	4016-25119-10	RES CHIP 0603 51.1 1%
R151	4016-25119-10	RES CHIP 0603 51.1 1%

Table 7-4. FTN6070A, MICOM-3T Control Head Board, Parts List

Reference Designation	Part No.	Description
R152	4016-18251-10	RES CHIP 8.25K 1% 1/8W
R153	4016-18251-10	RES CHIP 8.25K 1% 1/8W
R154	4016-52742-10	RES CHIP 0402 27.4K 1%
R155	4016-21000-10	RES SMD 100 1% 1/16W
R156	4016-25119-10	RES CHIP 0603 51.1 1%
R157	4016-25119-10	RES CHIP 0603 51.1 1%
R158	4016-25119-10	RES CHIP 0603 51.1 1%
R159	4016-27509-10	RES CHIP 0603 75 1%
R160	4016-27509-10	RES CHIP 0603 75 1%
R161	4011-61001-00	POT VOL/ON/OFF
R162	4016-10000-10	RES CHIP 1/8W JMPR 0.0
R163	4016-21000-10	RES SMD 100 1% 1/16W
R164	4016-21000-10	RES SMD 100 1% 1/16W
R165	4016-21000-10	RES SMD 100 1% 1/16W
R166	4016-21000-10	RES SMD 100 1% 1/16W
R167	4016-21000-10	RES SMD 100 1% 1/16W
R168	4016-21001-10	RES SMD 1.00K 1% 1/16W
R169	4016-21001-10	RES SMD 1.00K 1% 1/16W
R170	4016-21001-10	RES SMD 1.00K 1% 1/16W
R185	4016-23012-10	RES CHIP 0603 30.1K 1%
R186	4016-21502-10	RES SMD 15.0K 1% 1/16W
R187	4016-21003-10	RES SMD 100K 1% 1/16W
R188	4016-21009-10	RES CHIP 0603 10 1%
R189	4016-21009-10	RES CHIP 0603 10 1%
R190	4016-28251-10	RES SMD 8.25K 1% 1/16W
R191	4016-24751-10	RES SMD 4.75K 1% 1/16W
R192	4016-24751-10	RES SMD 4.75K 1% 1/16W
R193	4016-25119-10	RES CHIP 0603 51.1 1%
R194	4016-24752-10	RES SMD 47.5K 1% 1/16W
R195	4016-21501-10	RES SMD 1.50K 1% 1/16W
R196	4016-21502-10	RES SMD 15.0K 1% 1/16W
R197	4016-21502-10	RES SMD 15.0K 1% 1/16W
R198	4016-21009-10	RES CHIP 0603 10 1%
R199	4016-21009-10	RES CHIP 0603 10 1%
R200	4016-21009-10	RES CHIP 0603 10 1%
RT1	4023-60003-00	MULTIFUSE CHIP 500MA
RT2	4016-91103-20	TERM. NTC
U1	4021-20170-54	QUAD OP AMP.
U2	4021-50040-64	MICRO 8051 FLASH RAM UA
U3	4021-60409-54	SERIAL PROM ISP JTAG 3.
U5	4021-20195-84	V-REG LDO 3.3V/1A
U6	4021-44014-54	INVERTER HEX SCHMIDT
U7	4021-74015-54	EE POT. X9C104S
U8	4021-74015-54	EE POT. X9C104S
U10	4021-39026-64	FPGA SPARTAN II
U11	4021-00039-35	NPN DARL ARRAY ULQ2003
U12	4021-50095-64	CONTR. USB HOST/SLAVE E

Table 7-4. FTN6070A, MICOM-3T Control Head Board, Parts List

Reference Designation	Part No.	Description
U14	2112-21249-00	DC/DC/BUCK 1A SIMPLE SW
U15	2112-21249-00	DC/DC/BUCK 1A SIMPLE SW
U17	4021-22007-54	SW.REG.+5V 3A
U18	4021-70098-54	LINE TRANSCEIVER RS485/
U19	4021-70098-54	LINE TRANSCEIVER RS485/
U20	4021-70098-54	LINE TRANSCEIVER RS485/
U21	4021-22101-74	LDO 2V5 0.8A EN+ERROR
U22	4021-20311-54	OP. AMP. DUAL R TO R

Intentionally Left Blank

Table 7-5. MICOM-3F Parts List

Reference Designation	Part No.	Description
1	2704597K01	Chassis
2	1404860P01	PA insulator
3	0102700K23	HP-LORD, 40-pin flat cable
4	FTN6068A	High Power board
5	03010908A82	Screw, M3 × 0.5 × 8
6	03010911A11	Screw, M3 × 0.5 × 8
7	1504002P01	PA shield
8	1504596K01	Cover
9	3204012P01	Cover gasket
10	3904382P01	Lower contacts
11	3904381P01	Upper contacts
12	2604072P01	RF shield
13	FTN6067A	Low RF board
14	0310907C25	Screw, M3 × P0.5 × 16
15	0308390Y13	Screw, M6.0 × 1.0 × 40
16	0102700K22	HP-LORD, RF coax
17	0102701K51	Control Head-LORD, 40-pin flat cable
18	3204071P02	Front panel gasket
19	FLN2776A	Control Head gasket
20	FLN2272	Mobile mounting kit
21	4204841P01	Battery cover
22	0102703K64	Battery
23	04MB000008	Disk

MICOM-3F

Exploded View

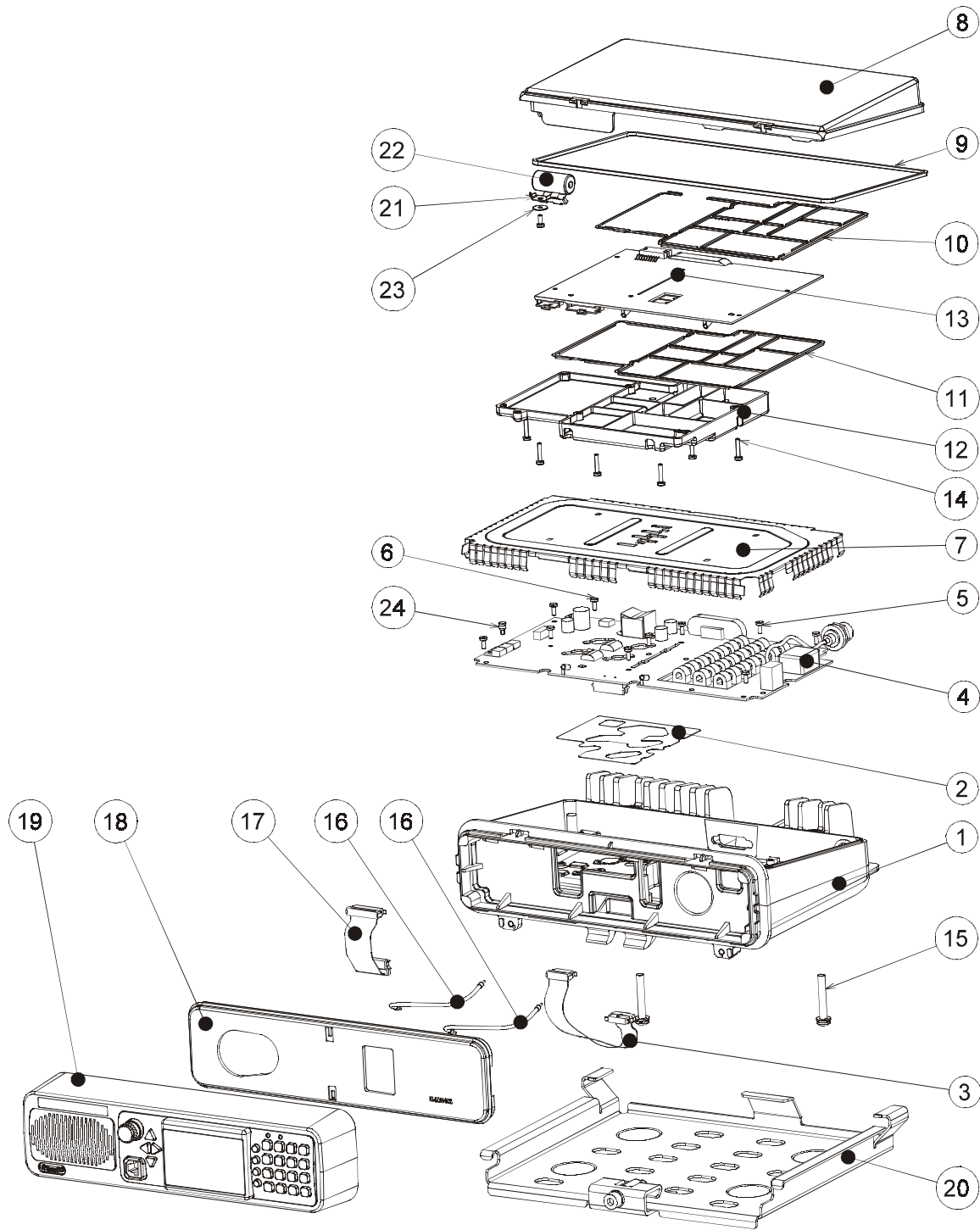

Table 7-6. MICOM-3T Parts List

Reference Designation	Part No.	Description
1	2704597K01	Chassis
2	1404860P01	PA insulator
3	0102700K23	HP-LORD, 40-pin flat cable
4	FTN6068A	High Power board
5	03010908A82	Screw, M3 × 0.5 × 8
6	03010911A11	Screw, M3 × 0.5 × 8
7	1504002P01	PA shield
8	1504596K01	Cover
9	3204012P01	Cover gasket
10	3904382P01	Lower contacts
11	3904381P01	Upper contacts
12	2604072P01	RF shield
13	FTN6067A	Low RF board
14	0310907C25	Screw, M3 × P0.5 × 16
15	0308390Y13	Screw, M6.0 × 1.0 × 40
16	0102700K22	HP-LORD, RF coax
17	0102701K51	Control Head-LORD, 40-pin flat cable
18	3204071P02	Front panel gasket
19	FHN5880A	Control Head gasket
20	0308390Y11	Mobile mounting kit
21	4204841P01	Battery cover
22	0102703K64	Battery
23	04MB000008	Disk

MICOM-3T

Exploded View

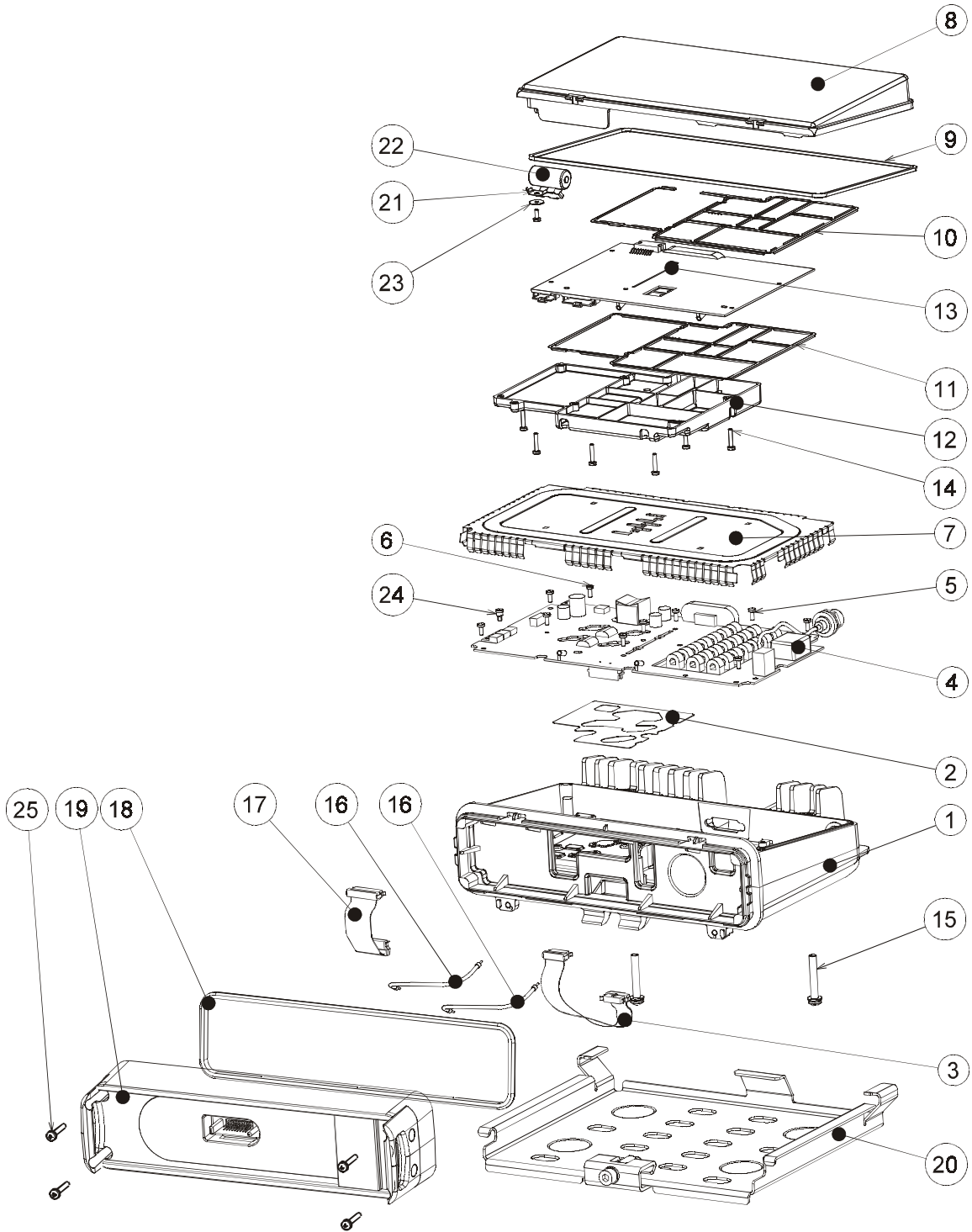

Table 7-7. MICOM-3R Parts List

Reference Designation	Part No.	Description
1	2704597K01	Chassis
2	1404860P01	PA insulator
3	0102700K23	HP-LORD, 40-pin flat cable
4	FTN6068A	High Power board
5	03010908A82	Screw, M3 × 0.5 × 8
6	03010911A11	Screw, M3 × 0.5 × 8
7	1504002P01	PA shield
8	1504596K01	Cover
9	3204012P01	Cover gasket
10	3904382P01	Lower contacts
11	3904381P01	Upper contacts
12	2604072P01	RF shield
13	FTN6067A	Low RF board
14	0310907C25	Screw, M3 × P0.5 × 16
15	0308390Y13	Screw, M6.0 × 1.0 × 40
16	0102700K22	HP-LORD, RF coax
17	0102701K51	Control Head-LORD, 40-pin flat cable
18	3204071P02	Front panel gasket
19	FLN2777A	Control Head gasket
20	0308390Y11	Mobile mounting kit
21	4204841P01	Battery cover
22	0102703K64	Battery
23	04MB000008	Disk

MICOM-3R

Exploded View

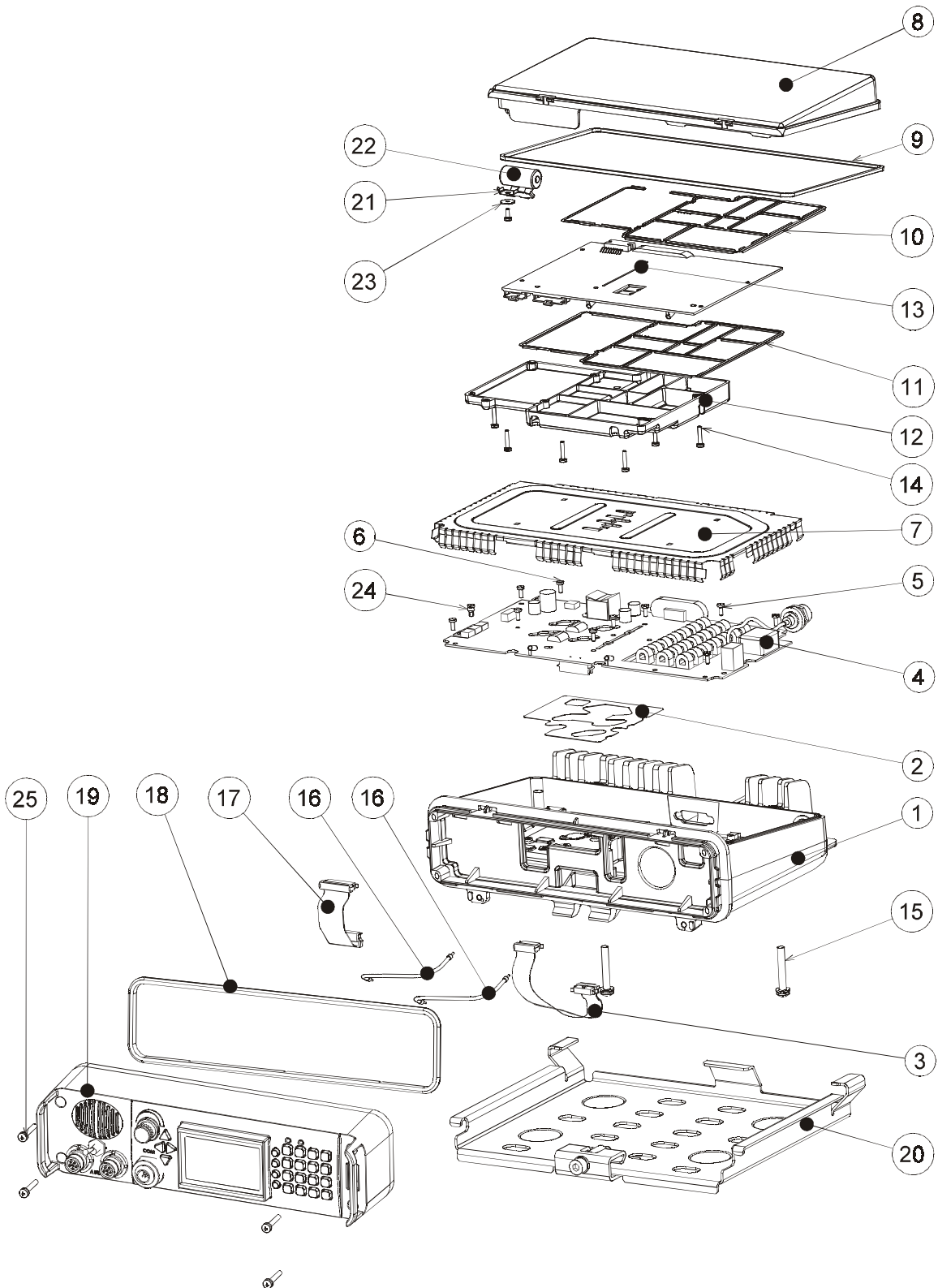

Table 7-8. Control Head Assembly, Parts List

Reference Designation	Part No.	Description
1	207248110-00	Panel
2	207232300-00	PCB
3	207242500-00	Insert
4	297248210-00	Window
5	207248220-00	Keypad left
6	297248230-00	Keypad
7	297233063-00	PCB USB
8	297232056-00	Pegged PCB
9	297240320-00	Gasket for speaker
10	297231051-00	Speaker
11	297240300-00	Plastic knob volume
12	297231011-00	Rubber knob volume
13	207241950-00	Screw M1.6-10
14	207248370-00	Plain washer M1.6
15	207252202-00	Tread forming screw
16	207252065-00	Tread forming screw
17	207248360-00	Spacer 4.3 × 8.0-7.0

Control Head Assembly

Exploded View

