

TESTING THE ESP504/520 220-222 MHz MOBILE RADIO USING THE IFR 1200 SUPER S SERVICE MONITOR



The ESP504 and 520 mobile units are advanced narrowband transceivers designed to be used in a 5 kHz channel spacing environment. These radios employ a novel modulation technique to keep the occupied bandwidth low (4 kHz) and still perform comparably to wider-bandwidth FM radios. The following guide was created to make servicing of the ESP504 and ESP520 mobile radios more convenient. For detailed information on this modulation technique and on the use, installation and servicing of these radios, refer to the ESP504/520 Instruction Manual, MAN-0504-01.

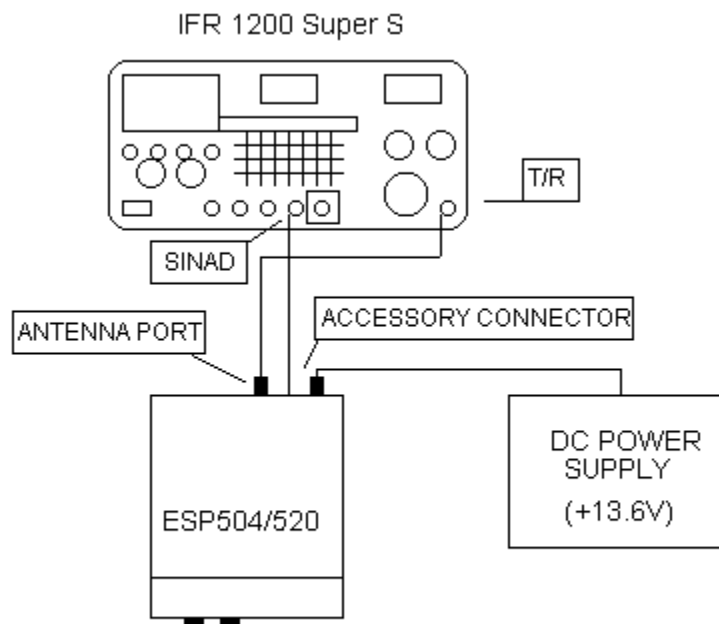

Figure 1 Receiver Test Setup

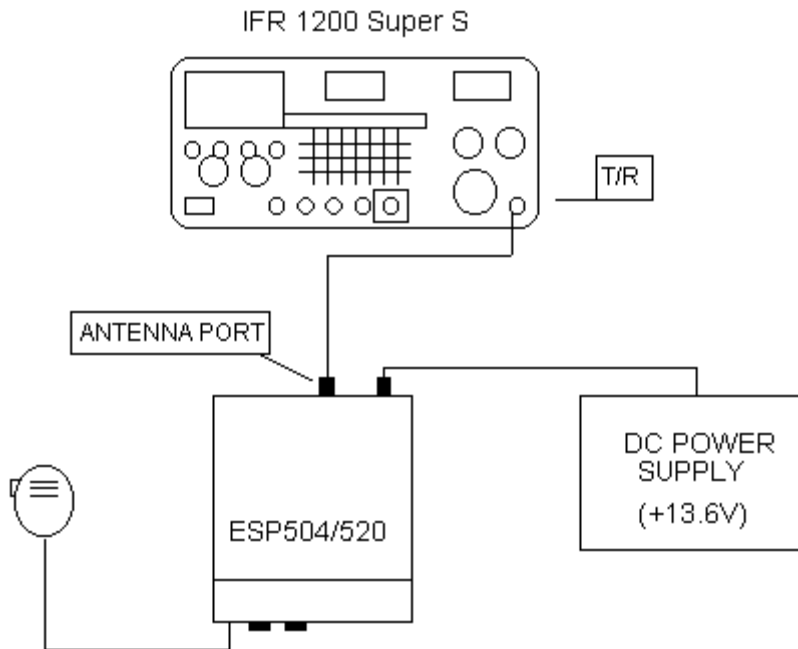

Figure 2 Transmitter Test Setup

1. PRELIMINARY SETUP - Entering Test Modes Condition

- a. Set up the radio to apply power from a power supply.
- b. Turn radio OFF.
- c. Install plug in mic jack which shorts TXd to RXd (pins 1 and 8) OR remove top cover and install jumper JU5 on Personality Board (ASY-0505-02).
- d. Turn radio ON. The radio is in Test Mode 1.
- e. On ESP504 verify that Mode 1 LED is on and there is no busy or fault tone from the radio.
- f. On ESP520 verify that display reads "*MODE 01" and there is no busy or fault tone from the radio.

Refer to Section 12 of the ESP504/520 Instruction Manual for detailed information on Field Test Modes.

2. RECEIVER TESTS

The receiver tests to be performed are 12 dB SINAD sensitivity, audio distortion, squelch sensitivity, and AFC lock range.

Definition: Standard Receiver Test Modulation (SRTM)

The required settings to create SRTM are as follows:

-Modulation Type:	AM
-RF Frequency:	220.0015 MHz (or the radio assigned frequency minus 1000 Hz)
- Modulation Frequency:	2900 Hz
- Modulation Level:	63%

2.1 12 dB SINAD Sensitivity

- a. Configure the test setup per Figure 1, **except do not hookup the audio output of the radio (accessory connector cable or ACC) to the EXT MOD/SINAD port yet.**
- b. Unsquench the receiver by pressing the HRN key in.
- c. Setup the IFR1200 to generate SRTM as follows:
 1. set MODE switch to GEN,
 2. set MODULATION switch to AM NORMAL,
 3. set METER switch to kHz/%x10 = 20,
 4. use keypad to set TONE = 2900 Hz,
 5. use keypad to set RF frequency = 220.0015 MHz,
 6. set TONE GENERATOR VAR switch to INTL,
 7. press keypad 2ND FUNCT, METER (display reads "0.0 kHz AM XXXX"),
 8. adjust TONE GENERATOR VAR pot for 63% read on display.
The service monitor is now generating SRTM.
- d. Set IFR1200 METER switch to SINAD. Note IFR1200 display now reads SINAD.
- e. Hookup the ACC to the EXT MOD/SINAD port.
- f. Set GEN LEVEL to .35uV/-116 dBm. IFR display should read >12 dB SINAD.

2.2 Audio Distortion

- g. Follow steps a, b and c of the section 2.1 12 dB SINAD Sensitivity Test.
- h. Remove the ACC from the EXT MOD/SINAD port and connect it to the SCOPE/DVM port.
- i. Set the IFR1200 scope: VERTICAL = 1V/div - HORIZONTAL = 1 mS/div
- j. Set input coupling switch to GND and adjust VERT POS for trace to appear at bottom of display.
- k. Set input coupling to AC. The display should show recovered audio.
- l. Set GEN LEVEL to -47 dBm (1000 uV).

- m. Adjust radio volume control for peak ac voltage displayed on scope = 5.6V. This will be loud if test is performed using the radio internal speaker as the load.
- n. Disconnect the ACC from the SCOPE/DVN port and connect it to the EXT MOD/SINAD port.
- o. Set METER switch to DIST.
- p. Press keypad 2ND FUNCT, METER to read distortion measurement from display. Should be $\leq 5\%$.

2.3 Squelch Sensitivity

- q. Set the radio to carrier squelch by pressing the HRN key so it is in the outward position and press the SCN key in. NOTE: the squelch will open intermittently. There is no adjustment for this.
- r. Set the IFR1200 as follows:
 1. install a 20 dB attenuator between the radio and the T/R port,
 2. set the GEN LEVEL to minimum (approx -130 dBm),
 3. set the TONE GENERATOR VAR switch to OFF (turns off modulation),
 4. set the RF frequency to 220.0044 MHz.
- s. Increase the GEN LEVEL until the squelch just opens. Level output should be < -109 dBm (squelch sensitivity -129 dBm).

Be sure to remove the 20 dB attenuator before performing any other tests.

2.4 AFC Lock Range

- t. Set the IFR1200 as follows:
 1. set the TONE GENERATOR VAR switch to INTL,
 2. set the GEN LEVEL to -116 dBm,
 3. set the RF frequency to 220.0018MHz
 4. set METER to kHz/ $\% \times 10 = 20$,
 5. select 2ND FUNCT, METER,
 6. adjust TONE GENERATOR VAR pot for 63% AM read on the display.
- u. Set the volume control on the radio so audio can be heard. 1000 Hz audio should be present. If so, the AFC is properly locking at the high extreme.
- v. Disconnect the rf cable from the T/R port (remove rf signal)
- w. Change the RF frequency to 220.0012 and reconnect the rf cable to the T/R port. 1000 Hz audio should be present. If so, the AFC is properly locking at the low extreme.

3. TRANSMITTER TESTS

The transmitter tests to be performed are transmitter power output and frequency accuracy.

3.1 Transmitter Power Output and Frequency Accuracy

- a. Set up the equipment as shown in Figure 2.
- b. Press the radio AUX key to put radio in simplex (MODE 1 LED flashing).
- c. Set the IFR1200 as follows:
 1. set RF frequency to 220.0025 MHz,
 2. set METER switch to WATTS/AVG/150,
 3. set FREQ ERROR switch to 300,
 4. press keypad 2ND FUNCT, METER.
- d. Set the mobile to transmit a 1kHz test tone by pressing the PGM key in. The mobile will now transmit a calibrated 1 kHz test tone, along with data carrier and pilot tone, when the mic PTT is depressed*.
- e. Press the PTT switch on the mic.
- f. Set the mobile to transmit a 2 kHz full power test tone* (with data carrier and pilot suppressed) by pressing and releasing the AUX key while the radio is in transmit.
- g. Read the power output from the radio on the IFR1200 display. Should be 18 to 22 watts.
- h. Read the frequency error from the FREQ ERROR meter. Error should be < 100 Hz.

* The spectrum sweeps of these signals may be observed by setting the scope display to HORIZONTAL = 1 kHz/div.