

SAILOR

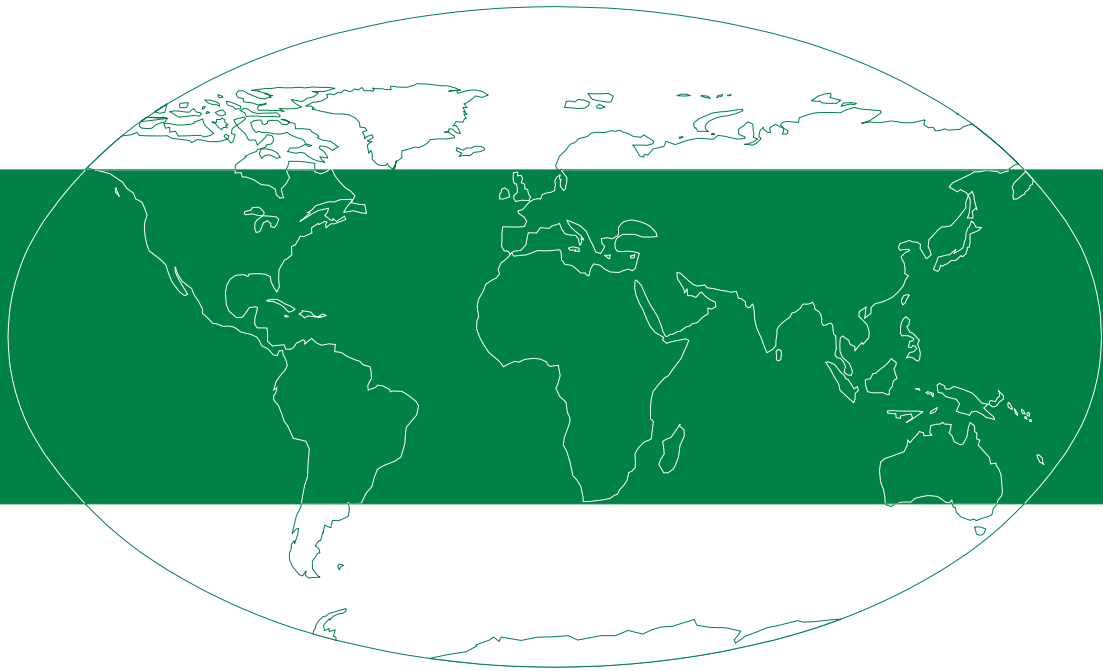

TECHNICAL MANUAL
FOR
COMPACT HF SSB N2161



S.P. RADIO A/S · AALBORG · DENMARK

Please note

Any responsibility or liability for loss or damage in connection with the use of this product and the accompanying documentation is disclaimed.

The information in this manual is furnished for informational use only, is subject to change without notice, may contain errors or inaccuracies, and represents no commitment whatsoever.

This agreement is governed by the laws of Denmark.

Doc. no.: M2161GB

Issue: A/0129

1 INTRODUCTION

1.1 GENERAL DESCRIPTION

N2161 is a power supply unit constructed for supplying the Transmitter T2130 from the mains.

N2161 makes an automatic change-over from mains supply to battery supply in case of mains failure.

N2161 has a built-in 12V DC regulator for supplying a VHF radiotelephone. However, the N2161 cannot supply the VHF radiotelephone and the transmitter T2130, when both are transmitting simultaneously, due to the current limiter in N2161.

N2161 is short-circuit protected at the output by means of a current limiter.

1.2 TECHNICAL DATA

Input Voltage:	110V - 127V - 220V - 240V AC
Input Frequency:	50 - 60 Hz
Output Voltage:	30.5V DC \pm 1V at 1A load
Output Current:	0.1 - 20A continuously
Output Limit:	25A for max. 15 minutes
Output Protection:	25A current limiter
Noise into Mains:	Better than CEPT
Operating Temperature:	-15°C to +55°C
On/Off Control:	From T2130 or VHF

12V VOLTAGE REGULATOR

Output Voltage:	13.2V DC \pm 10%
Output Current:	Max. 8A
Output Protection:	Fuse 8A

1.3 PRINCIPLE OF OPERATION

The Power Supply N2161 is an insulated thyristor rectifier. The thyristors are placed on the secondary side of a mains transformer to minimize the interference on the mains.

The mains voltage is transformed down by the mains transformer. This voltage is then rectified by the phase controlled rectifier bridge. By varying the phase, the turn-on time, it is possible to control the average value of the direct voltage applied to the load.

The control unit measures the output voltage of N2161 and controls the turn-on time for the thyristors. The output from the rectifier bridge is incomplete sine waves. These pulses are then filtered by the output LC-filter to an average DC-voltage.

The control unit also measures the output current and reduces the output voltage if the current is too high. Constant current mode.

1 INTRODUCTION

N2161

The output voltage is connected to the battery voltage via a diode. Normally the output voltage from the N2161 is higher than the battery voltage and the diode is not conducting. But if the output voltage of N2161 is lower than the battery voltage, then the battery takes over the supply to the transmitter. This is an automatic change-over if the mains fails. The transmitter is always supplied by the N2161 if N2161 is ON. The N2161 can be switched on/off by the on/off input.

The 12V voltage regulator is a linear serial regulator where most of the loss is dissipated in resistors. It is provided with a terminal for remote shut-down. If the on/off terminal is connected to the -terminal, the regulator is ON. If the on/off terminal is disconnected, the regulator is off.

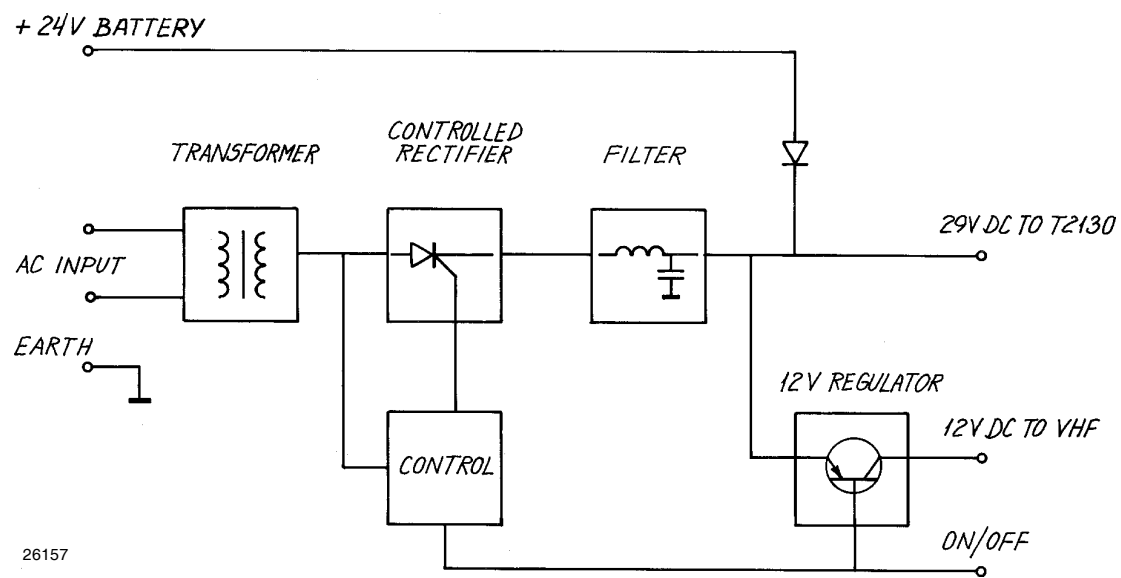

26157



N2161

2 INSTALLATION

2.1 MOUNTING POSSIBILITIES/DIMENSIONS AND DRILLING PLAN

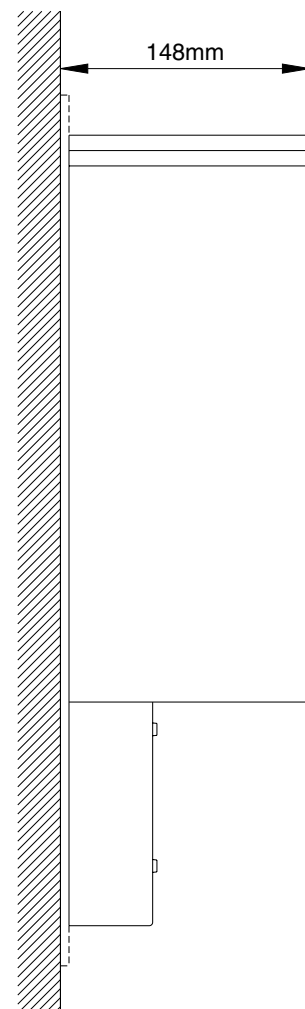
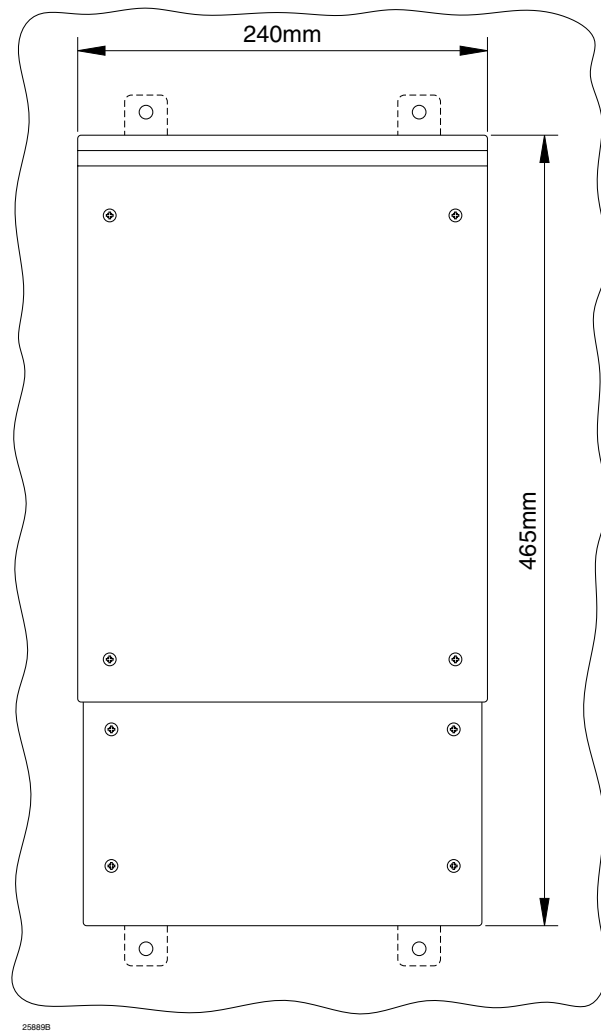

9727

PAGE 2-1



2 INSTALLATION

N2161

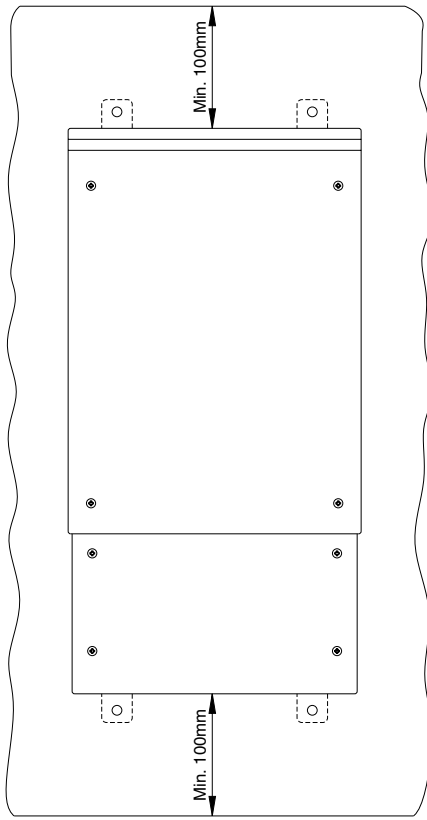

Free Space for air circulation.
Ambient temperature: max. 40° C.
Weight: N2161 22.5 kg

Free space for air circulation
and cable entry.

25891B

26197A

PAGE 2-2

9727

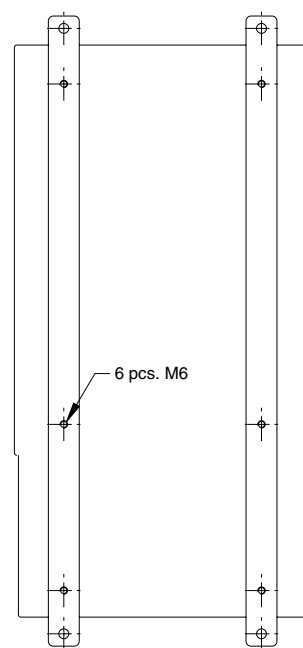
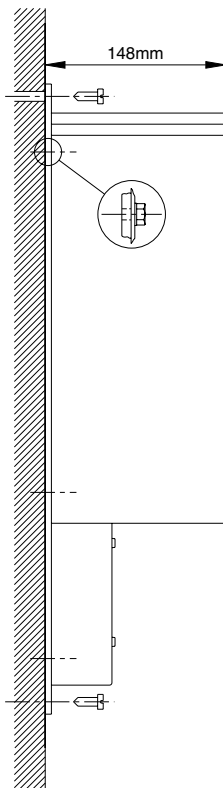
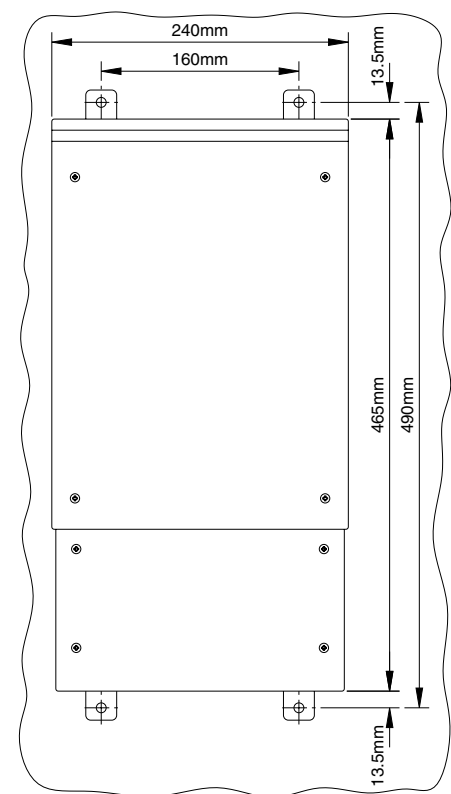

2.2. ELECTRICAL CONNECTION

2.2.1. MAIN CABLE PLAN WHEN CONNECTED TO HF SSB T2130

Note 1, 2 and 3

Distance/cable dimensions table

Distance in meters	1.3	2	3.2	5	8	10	13	16	24	34	Mains fuse
Copper cable dimensions in mm ²											
Note 1 T2130 DC supply cables 24V DC approx 13A and N2161 DC supply cables 24V DC approx 13A	1.5	2.5	4	6	10	10	16	16	25	35	
Note 2 N2161 AC supply cables 220V AC approx 3A 110V AC approx 6A	1.5	1.5	1.5	1.5	1.5	1.5	1.5	1.5	1.5		10A 10A
Note 3 N2160 DC supply cables 12V DC approx 50A	4	6	10	16	25	35	50	70	95	120	

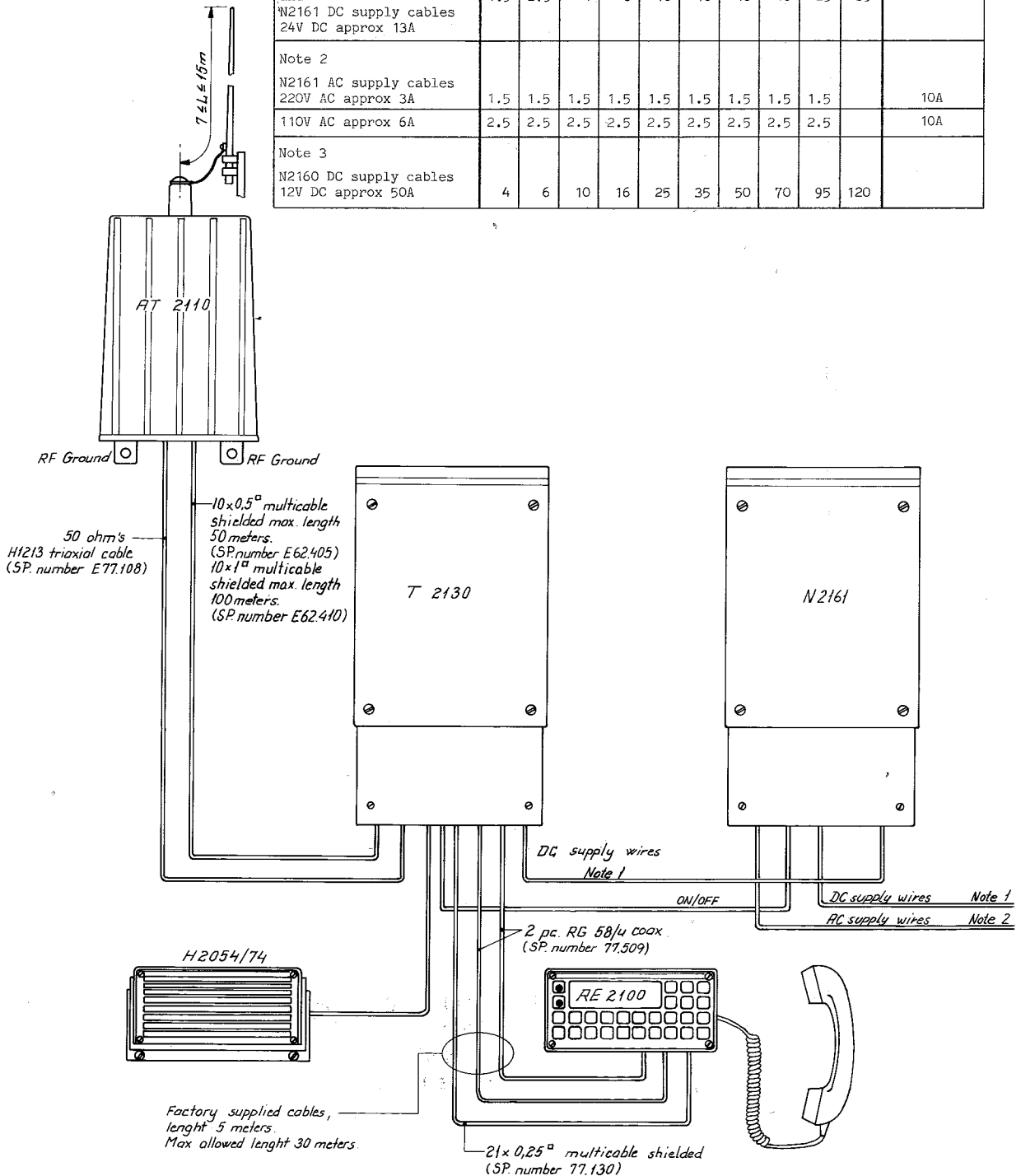

N2161 4-0-26109A

2.2.2. CONNECTIONS TO N2161

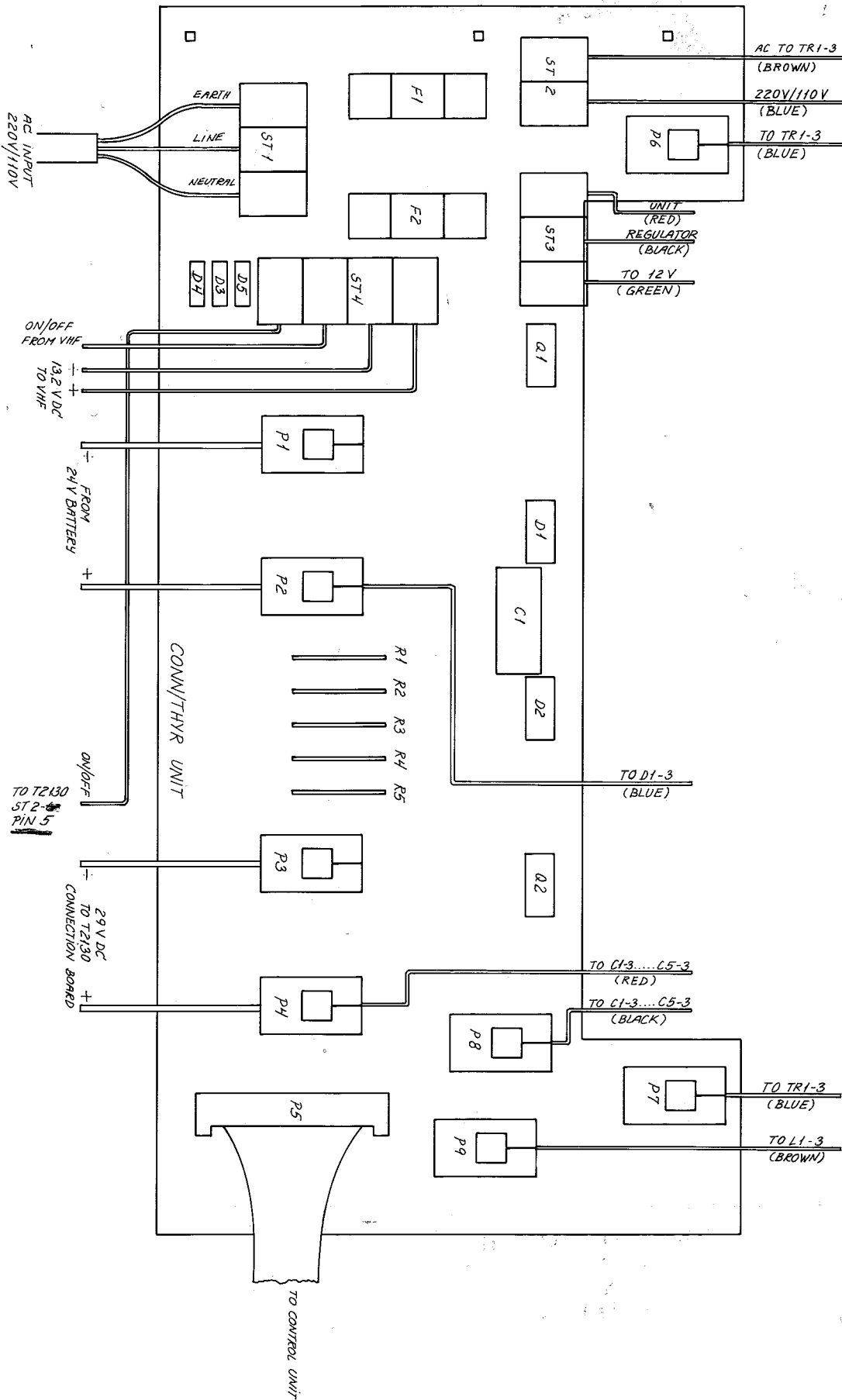

N2161 4-0-26199

3. SERVICE

3.1. MAINTENANCE

When the SAILOR N2161 has been correctly installed, the maintenance of the power supply can, dependent on the environments and working hours, be reduced to a performance check at the service workshop at intervals not exceeding 5 years.

A performance check list is enclosed in the section 3.4. PERFORMANCE CHECK.

Also inspect cables and plugs for mechanical defects and corrosion.

Any repair of the set should be followed by a check described in the section 3.5 NECESSARY ADJUSTMENT AND CHECK AFTER REPAIR.

3.2. RECOMMENDED TEST EQUIPMENT

Multimeter	Philips PM2518X
Oscilloscope	Philips PM3214

3.3. TROUBLE SHOOTING

Trouble shooting, repair and check of N2161 should only be performed by persons, who have the sufficient technical knowledge and the necessary test equipment at their disposal.

1. The output voltage at the 29V DC terminals is too low:
 - a. The N2161 is overloaded. Max. output current is 25A.
 - b. Wrong adjustment. See the chapter 3.5. NECESSARY ADJUSTMENT AND CHECK AFTER REPAIR to adjust the output voltage.

2. The output voltage at the 29V DC terminals is too high:
 - a. Wrong adjustment. See the chapter 3.5. NECESSARY ADJUSTMENT AND CHECK AFTER REPAIR to adjust the output voltage.
 - b. The control unit is out of order.
 - c. Bad connections for the wires connected to plug P5-1 pin 4 or 8.
 - d. No load is connected to the 29V DC output terminals while the N2161 is switched on. To obtain a proper regulation, it is recommended to connect a small dummy load to the 29V DC output terminals. A resistor of 330 ohm/4W is sufficient.

3. No output voltage at the 29V DC output terminals:
 - a. The on/off circuit is out of order.
 - b. The fuses on the connector/thyristor unit are blown out.
 - c. The diode D1-1 or D2-1 or the thyristor Q1-1 or Q2-1 is defective.
 - d. The control unit is out of order.
 - e. The 17V AC wire from trafo TR1-3 to the control unit is broken.

3.4. PERFORMANCE CHECK

Any value, which differs too much from the values given in this chapter, should lead to a repair and/or adjustment of the circuit in question. Please see the chapter 3.5. NECESSARY ADJUSTMENT AND CHECK AFTER REPAIR.

3.4.1. PERFORMANCE CHECK OF 29V DC

1. Connect the N2161 to the AC mains, which it is strapped for. Normally the N2161 is strapped for 220V AC.
2. Connect a small dummy load to the 29V DC output terminals P3-1 and P4-1. A resistor of 330 ohm/4W is sufficient to get a proper regulation.
3. Connect the on/off T2130 terminal ST4-1 pin 1 to the -29V DC terminal P3-1 to switch on the N2161.
4. Measure across the 29V DC output terminals with a voltmeter and read 31.0V DC $\pm 0.5V$.

3.4.2. PERFORMANCE CHECK OF CURRENT LIMITER

1. If this check is the only one executed, please first execute chapter 3.4.1. PERFORMANCE CHECK OF 29V DC.
2. Connect a dummy load to the 29V DC output terminals to get a load of 25A at 26V DC output voltage. Then connect a resistor load of 1.04 ohm, which can be made by paralleling several power resistors so it can handle up to 700W.
NOTE! The current limiter is only a peak current limiter. Therefore the N2161 must only work at current limiting for max. 15 minutes at 40°C ambient temperature.
3. Switch on the N2161 by connecting the on/off T2130 terminal ST4-1 pin 1 to the -29V DC terminal P3-1.
4. Connect a voltmeter across the 29V DC output terminals and read 26.0V DC $\pm 0.5V$ at a load of 25A.
5. Connect a scope to the 29V DC output terminals and check that the ripple is less than 2Vpp at full load.
6. Switch off the N2161 and disconnect the dummy load.

3.4.3. PERFORMANCE CHECK OF 12V REGULATOR

1. If this check is the only one to be executed, please first execute chapter 3.4.1. PERFORMANCE CHECK OF 29V DC.
2. Connect a dummy load of 1.85 ohm/100W to the 12V DC output terminals ST4-1 pin 3 and 4.
3. Connect the on/off VHF terminal ST4-1 pin 2 to the -29V DC terminal P3-1 to switch on the 12V regulator and the N2161.
4. Connect a voltmeter across the dummy load and read 13V DC $\pm 1V$ at a load of 7A.
5. Connect a scope across the dummy load and check that the ripple is less than 50mVpp.

3.5. NECESSARY ADJUSTMENT AND CHECK AFTER REPAIR

Change or Repair of Connection/Thyristor Unit (Module 1) or of Control Unit (Module 2)

Execute chapter 3.4.1. PERFORMANCE CHECK OF 29V DC and adjust if necessary the output voltage to 31.0V DC $\pm 0.1V$ with R13-2.

Then execute chapter 3.4.2. PERFORMANCE CHECK OF CURRENT LIMITER, point 1 to 4. Adjust if necessary the current limiter with R44-2 until the output voltage is 26.0V DC $\pm 0.1V$ at a load of 25A.

The current limiter is only a peak current limiter, therefore the N2161 must only work at current limiting for max. 15 minutes at 40°C ambient temperature.

Change or Repair of Chassis Mounted Components

Execute chapter 3.4. PERFORMANCE CHECK.

Change or Repair of 12V Regulator Unit

Execute chapter 3.4.3. PERFORMANCE CHECK OF 12V REGULATOR.

3.6. ADJUSTMENT LOCATIONS

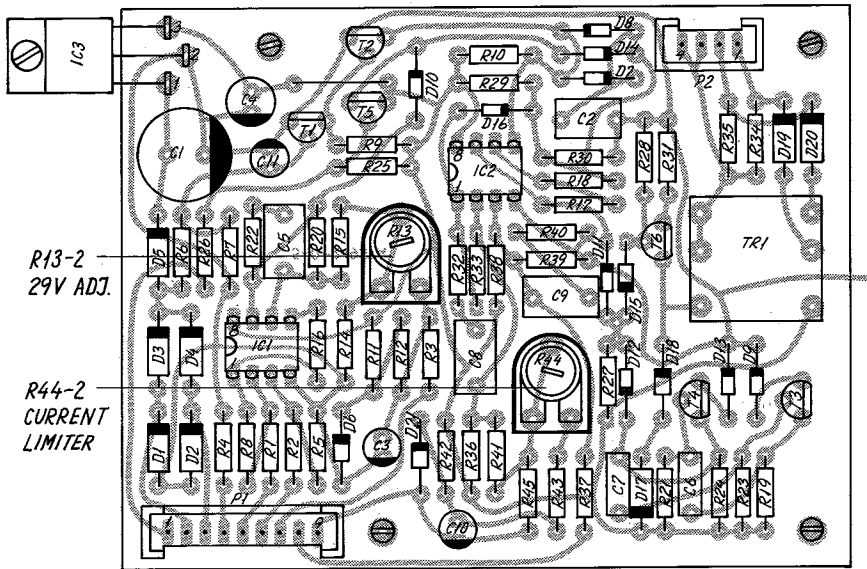

R13-2
29V ADJ.

R44-2
CURRENT
LIMITER

CONTROL UNIT (MODULE 2)

4-6-24957 4-9-24957

N2161

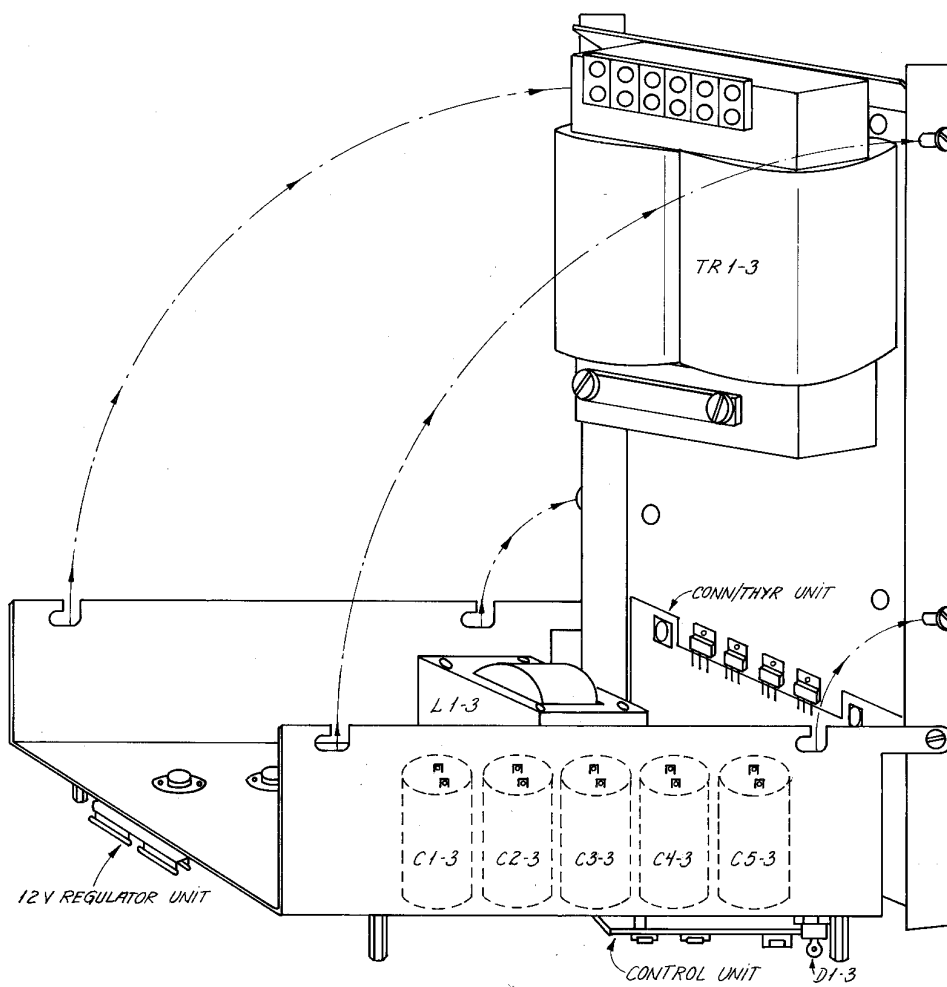
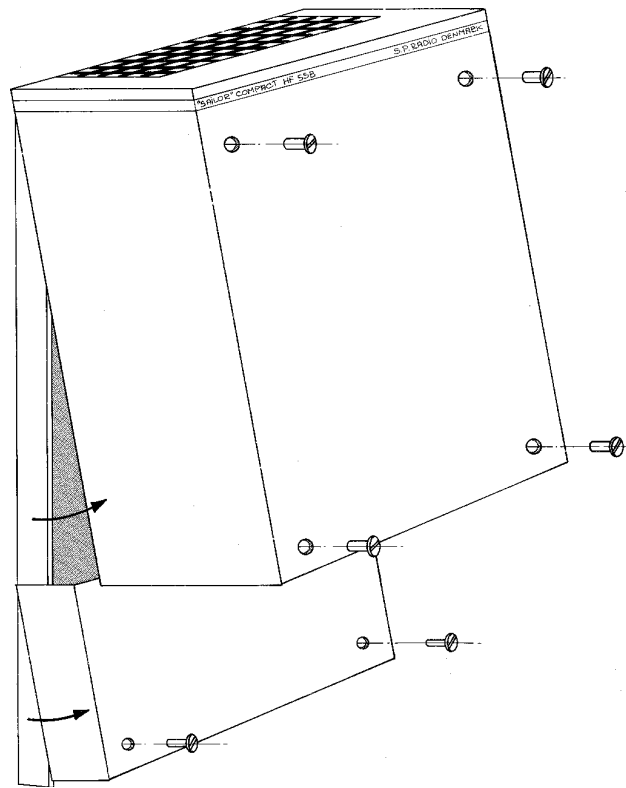

4-0-25892, 4-0-26156

5. CIRCUIT DESCRIPTION

5.1. CONNECTION/THYRISTOR UNIT (MODULE 1)

The thyristor unit also serves as a connection board for the thyristors Q1-1, Q2-1, and the diodes D1-1, D2-1, and the cable entry.

The capacitor C1-1 of 2.2uF limits the dV/dT across the thyristors to prevent false triggering, and reduces noise into the mains.

In the module 1, the current sense resistors R1-1 to R5-1, and the mains fuses F1-1 and F2-1 are placed together with all the main connectors for connections to the surroundings.

The 46V AC from TR1-3 is fed to the thyristor unit. The turn-on time is controlled by the Control Unit (Module 2).

When the thyristor is turned on, a rectified AC voltage is fed to the output smoothing capacitors C1-3 to C5-3 through the inductor L1-3. When the rectified AC voltage is higher than the output voltage, the current starts to run in inductor L1-3. When the rectified AC voltage again become smaller than the output voltage, the inductor forces the current in the thyristors to continue to the zero crossing of the AC voltage. At this moment the thyristors turn off instantly. In the next period it is the other thyristor, which is turned on by the control unit. The current sense resistors R1-1 to R5-1 is used by the control unit to measure the output current.

5.1. COMPONENT LOCATION CONNECTION/THYRISTOR UNIT (MODULE 1)

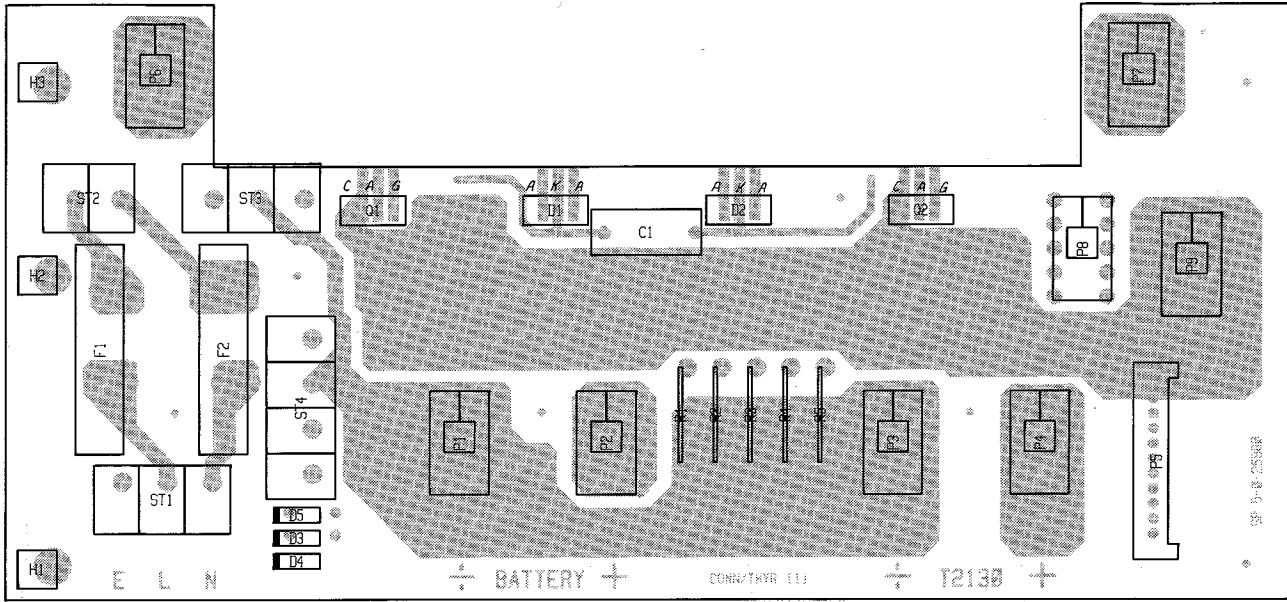

Seen from component side with upper side tracks

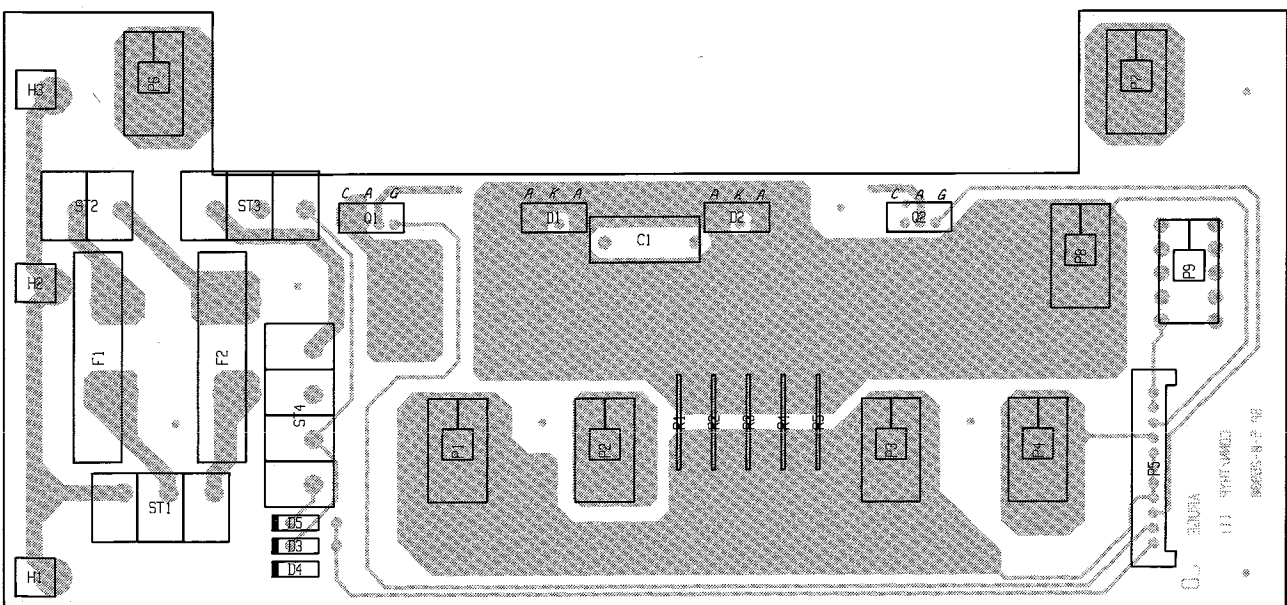

Seen from component side with lower side tracks

Connection/Thyristor Unit (1)

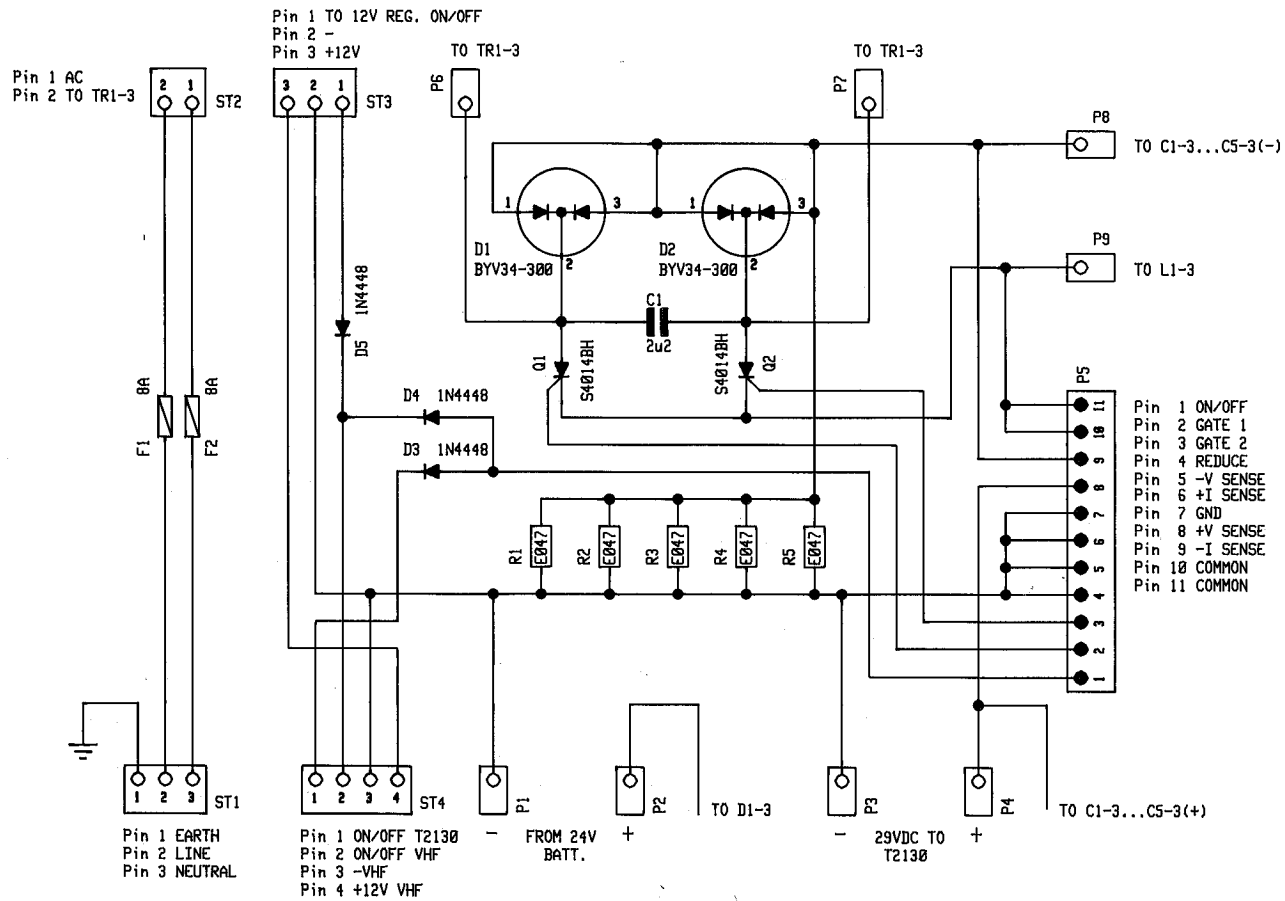

5.2. CONTROL UNIT (MODULE 2)

The control unit produces the necessary pulses to the thyristors. These thyristors are the stabilizing element for the 29V output voltage.

17V AC from the mains transformer TR1-3 is rectified by the diodes D1-2 to D4-2. This full wave rectified sine wave is then peak rectified by D5-2 and C1-2 and led to IC3-3. This is a fixed 15V voltage regulator, which delivers all the supply current to the other components on the board. The full wave rectified sine wave is in addition led to the base of T1-2 through R6-2. T1-2 is conducting most of the time, but is off for a short period around the zero crossing of the sine wave. In this short period T2-2 is conducting and discharges C2-2 through D8-2. C2-2 is discharged down to approx. 0.7V, the forward voltage in D8-2. The voltage on pin 5 on IC2a-2 is then nearly zero.

When T2-2 stops conducting, this voltage rises instantly with two forward diode voltages from D7-2 and D8-2. C2-2 starts to be charged by R10-2 and D7-2. The voltage on pin 5 now rises with a nearly constant slope. T2-2 starts discharging C2-2 again, etc. This takes place two times every period of the mains frequency.

This ramp voltage is compared with the control voltage at the common point of R18-2, R29-2, R30-2, D14-2 and D16-2 by IC2a2. If the ramp voltage is smaller than the control voltage, the output pin 7 of IC1a2 is low. The combination of T3-2 and T4-2 makes a 7 kHz astable multivibrator. The diodes D9-2 and D13-2 eliminate the influence of spreads in base-emitter break-down voltages of the transistors.

This 7 kHz is gated together with the signal from the comparator IC2a-2 and fed to T6-2. If the voltage on pin 7 at IC2a2 is low, the 7 kHz signal is not allowed to pass to T6-2. D15-2 ensures a proper turn on and off of T6-2, which acts as a constant AC current source to the trigger transformer TR12. The current is determined by the supply voltage, R27-2, R28-2, R31-2 and D15-2 to approx. 100 mA. The combination D17-2 and D18-2 demagnetizes TR1-2.

The current signal is amplified by a factor 3:1:1 by TR1-2, rectified by D19-2, and D20-2 and led to the thyristors. R34-2 and R35-2 prevent false triggering of the thyristors.

The control voltage can never be less than approx. 0.7V due to R29-2 and R30-2, but the ramp voltage is always less than 0.7V every time the mains frequency is zero crossing. Therefore, pin 7 at IC2a-2 goes low and prevents the 7 kHz trigger signal from reaching the thyristors. The thyristors are thus ensured a proper turn off of one thyristor before the other is turned on.

If the on/off terminal pin 1 in P1-2 is floating, the transistor T5-2 will pull up the control voltage point to approx. 14V. The maximum voltage of the ramp voltage is approx. 8V, so the output voltage of IC2a-2 is then permanently low, and no trigger signal is led to the thyristors. If the on/off terminal is connected to ground, T5-2 is reverse biased and has no influence on the control voltage.

By varying the control voltage, the moment of triggering the thyristors on sine wave is varied, and thus the output voltage.

5.2. CONTROL UNIT (MODULE 2)

The +29V output voltage is sensed by the common mode amplifier IC1a-2 and divided down to 3.8V. A common mode amplifier is used to remove the sensitivity to noise. This voltage is compared to the reference voltage from D6-2, divided by R12-2, R13-2, and R14-2. The difference is amplified by IC2b-2 (voltage error amplifier) and led by D10-2 and D14-2 to the control voltage point.

When pin 7 in P1-2 is grounded, R3-2 bypasses some of the current around R13-2 and reduces the reference potential for IC2b-2.

The output current is sensed by R1-1 to R5-1. The voltage is led to P1-2, pin 8 and P1-2, pin 9. This voltage is compared with a reference voltage produced by D21-2, R43-2, R44-2, and R45-2 in the common mode amplifier IC2b2. The two resistors R36-2 and R38-2 offset the amplifier to ensure that the input common mode voltage range of IC2b-2 is not exceeded. The error voltage is fed to the control voltage point at D16-2.

The diodes D10-2, D14-2, and D16-2 ensure that the highest voltage of the error voltages has the highest priority.

The output voltage is adjusted by R13-2
The output current is adjusted by R44-2.

5.2. COMPONENT LOCATION CONTROL UNIT (MODULE 2)

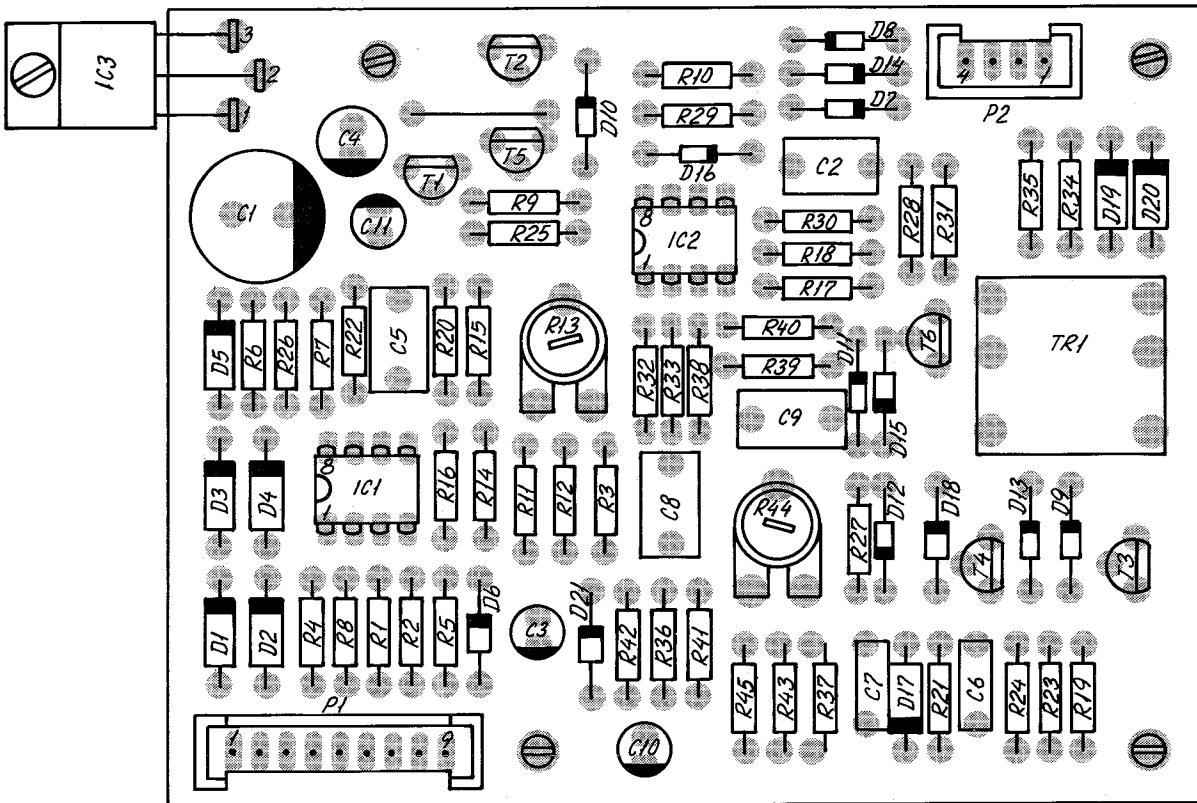

Seen from component side with upper side tracks

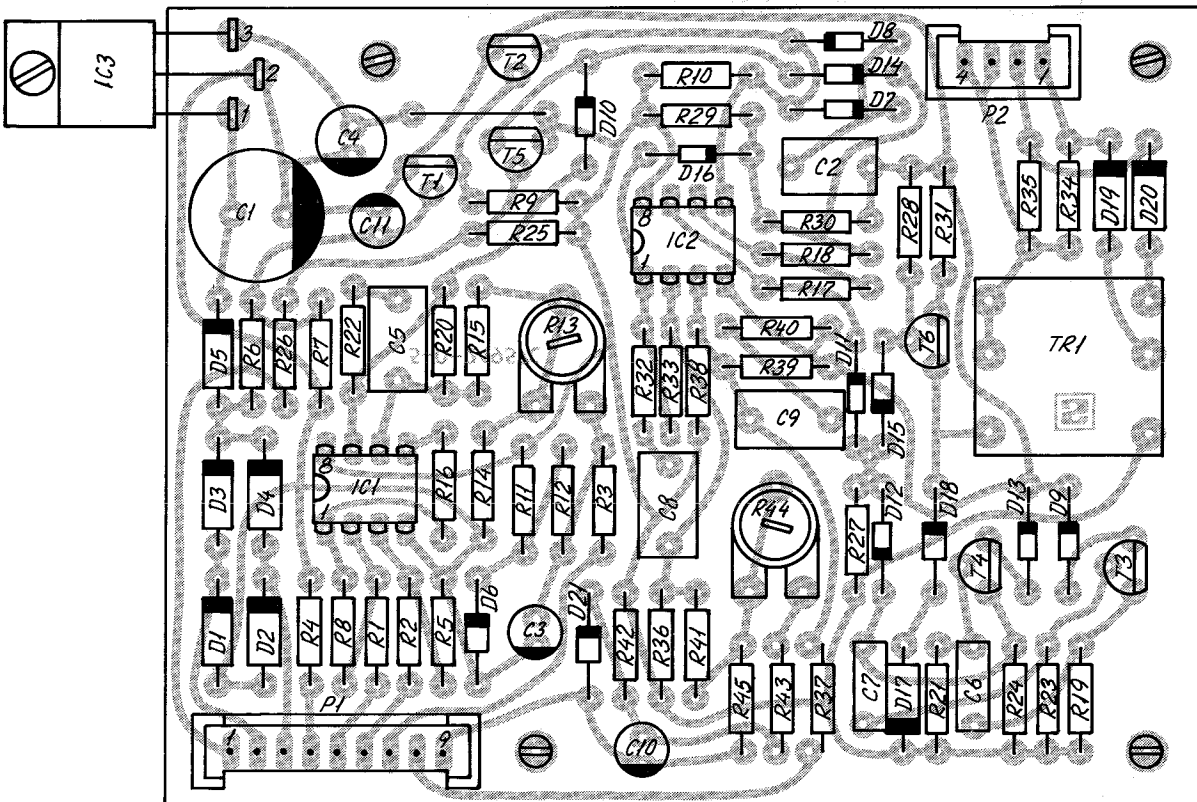

Seen from component side with lower side tracks

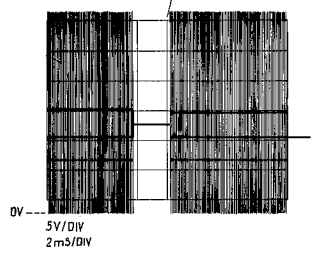
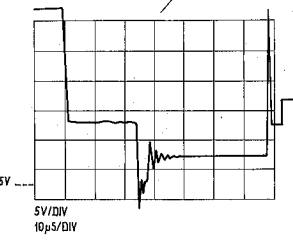
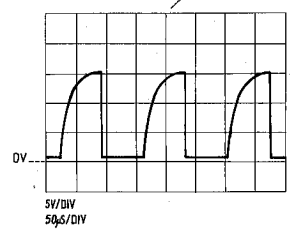
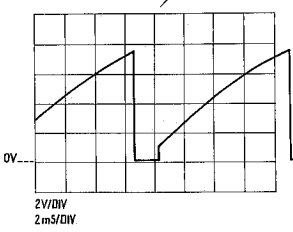
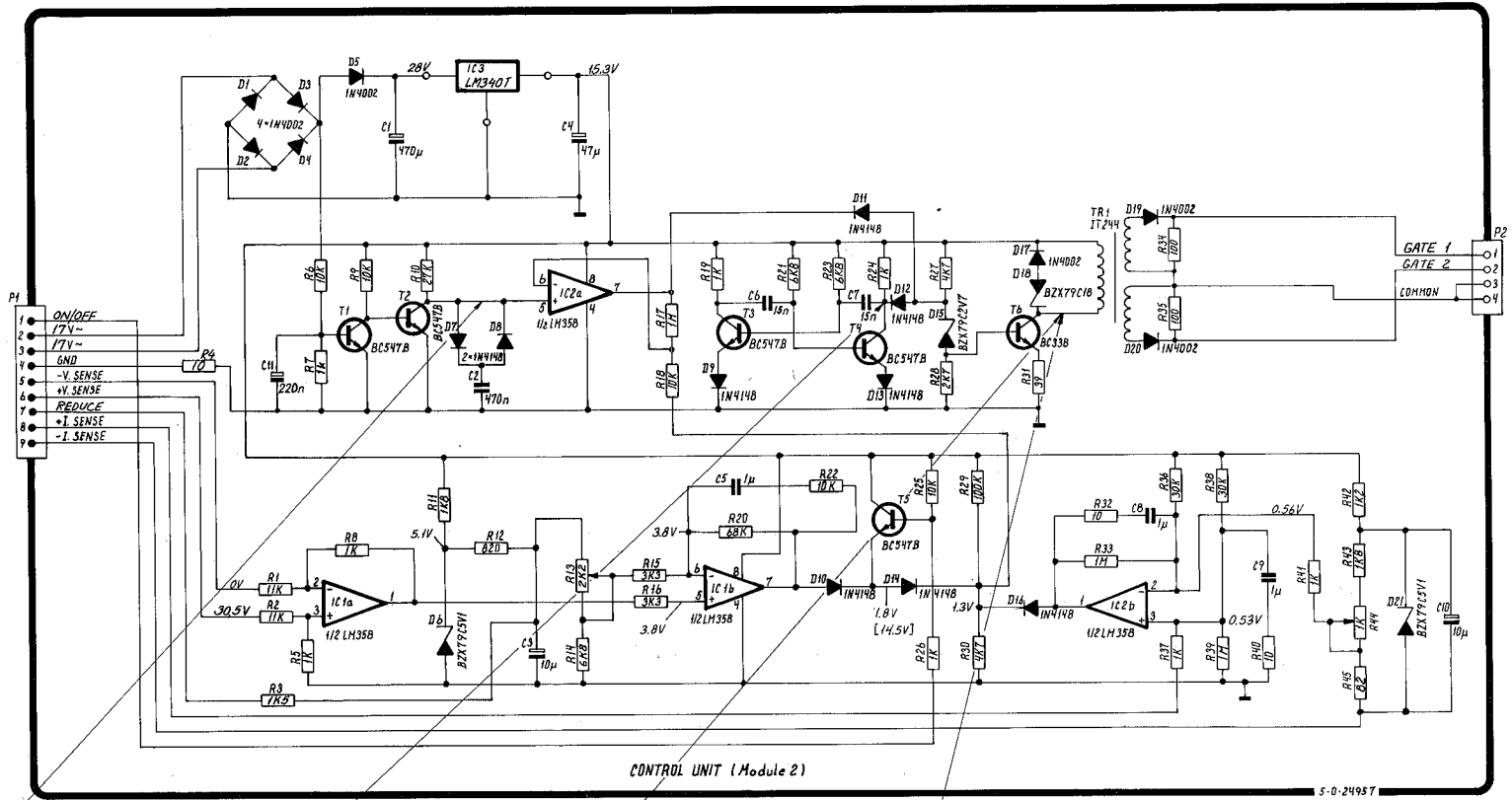

CONTROL UNIT MODULE 2

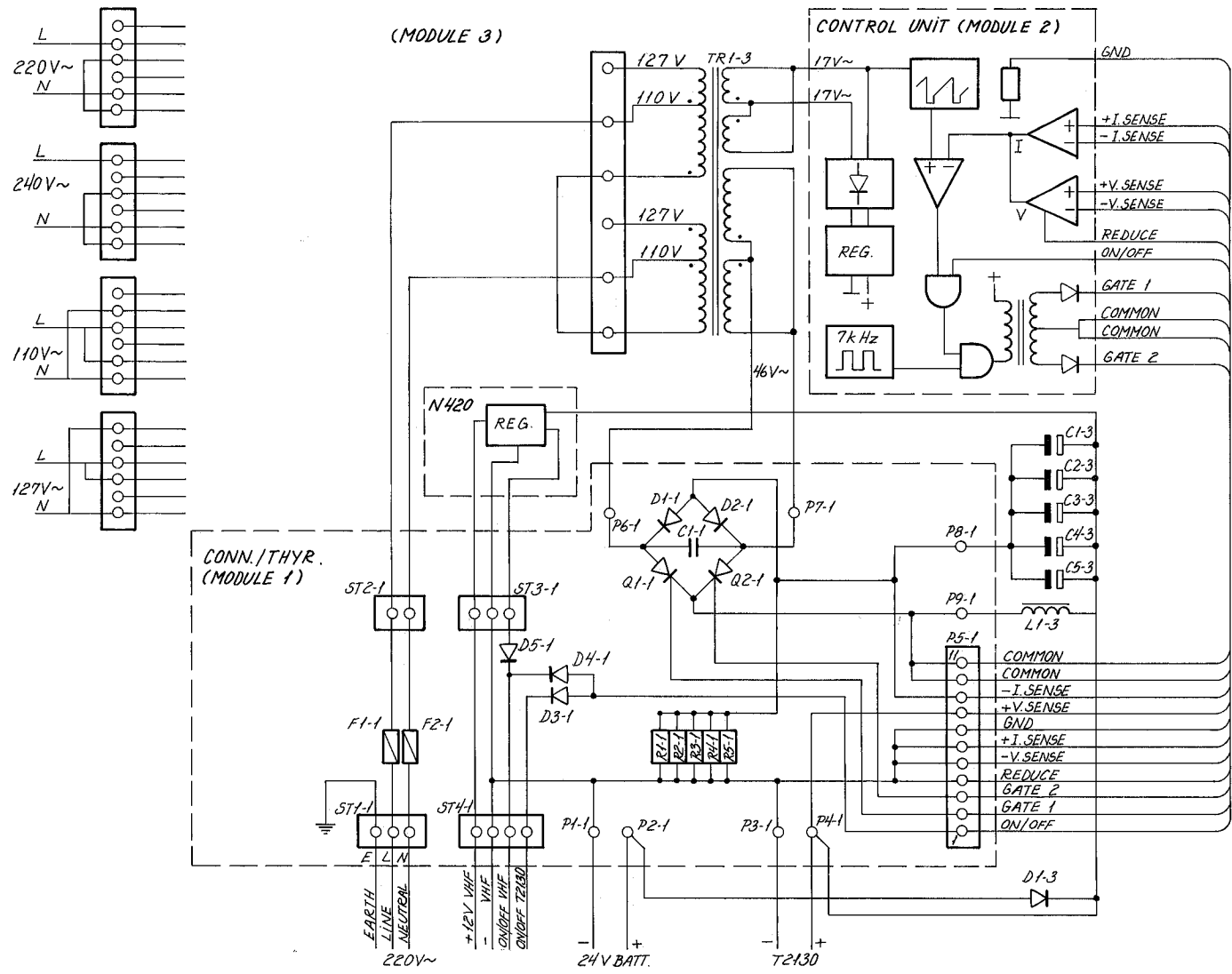

5.4. 12V VOLTAGE REGULATOR

The output voltage is regulated by the integrated voltage regulator IC1. The output voltage is 12V DC plus the forward voltage of the diodes D5 and D6 approx. 13.4V DC, if T4 is turned on.

If the output voltage falls, the current through IC1 and R5 increases. An increase in voltage across R5 will result in an increase in T1 and R10-R23, and the output current. T1 delivers most of the output current and IC1 only a small driver current.

If the input voltage is low and the output current is high, the voltage across R10-R23 causes T1 to go into saturation. The voltage across R4 increases, and when the voltage across R4 and V_{BE} of T1 is higher than approx. 1V, T3 starts to conduct base current to T1. This transistor starts to shunt the remaining current to the output, bypassing R10-R23.

When the input voltage and the output current are high, T1 is nearly saturated. When the input voltage is low and the output current is high, the resistors R1-R3 will result in saturation of both T1 and T2. The combination of T1 in saturation and T2 delivering the remaining output current divides the total loss, so that the most is lost in resistors and gives us lower loss in the semi-conductors and lower junction temperature, which ends up in a higher reliability for the whole regulator.

T4 is used to switch the regulator on/off. If the on/off input is disconnected, T4 is off, and the base currents to T1 and T2 are zero and the current through IC1 is zero too. The standby current consumption is then less than 10 microamp.

If the on/off input is connected to -input, T4 goes into saturation and the regulator starts.

In case of short-circuit of the output, R5 and D3 limit the current through IC1 and T4 to approx. 250 mA, and R1-R3 and D3 limit the current through T1 and T2 to approx. 15 Amp.

The temperature on the heatsink will increase and activate the thermal protection circuit inside IC1 and lower the output voltage, even though a short-circuit of the output should be avoided.

The diode D1 protects against reverse input voltage. It blows the fuse in case of a wrong input connection.

The zener diode D4 acts as an input voltage transient protection.

5.4. COMPONENT LOCATION 12V VOLTAGE REGULATOR

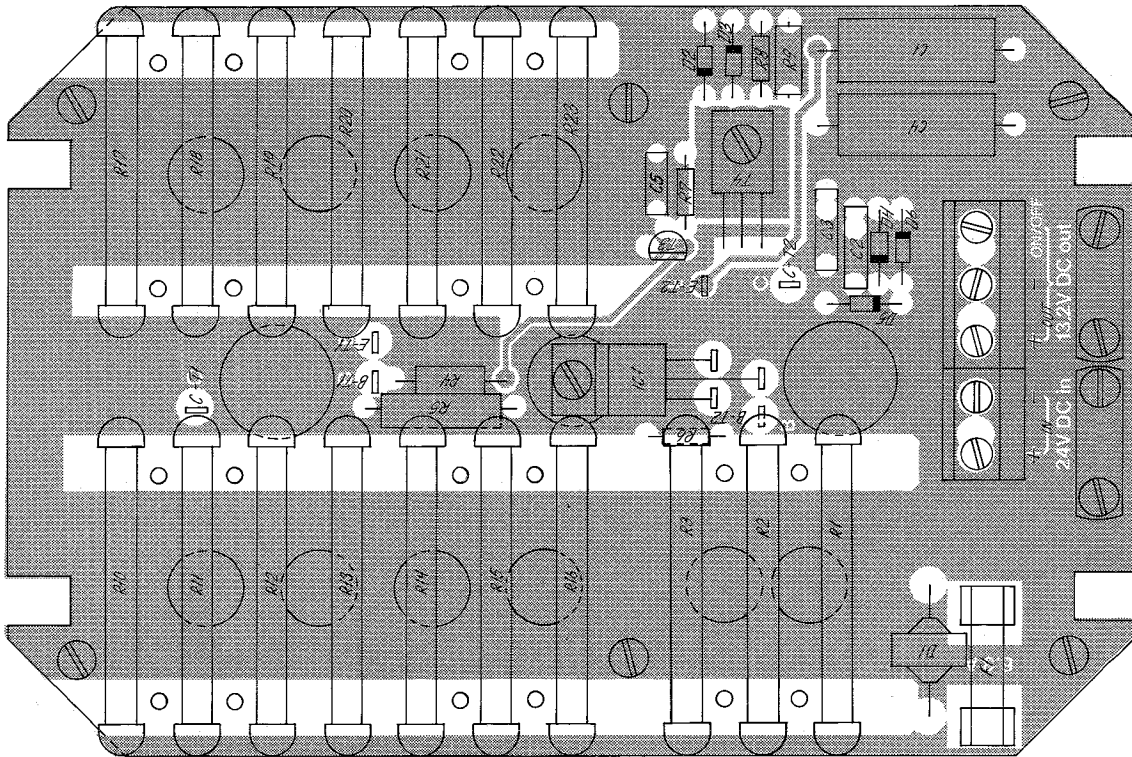

Seen from component side with upper side tracks

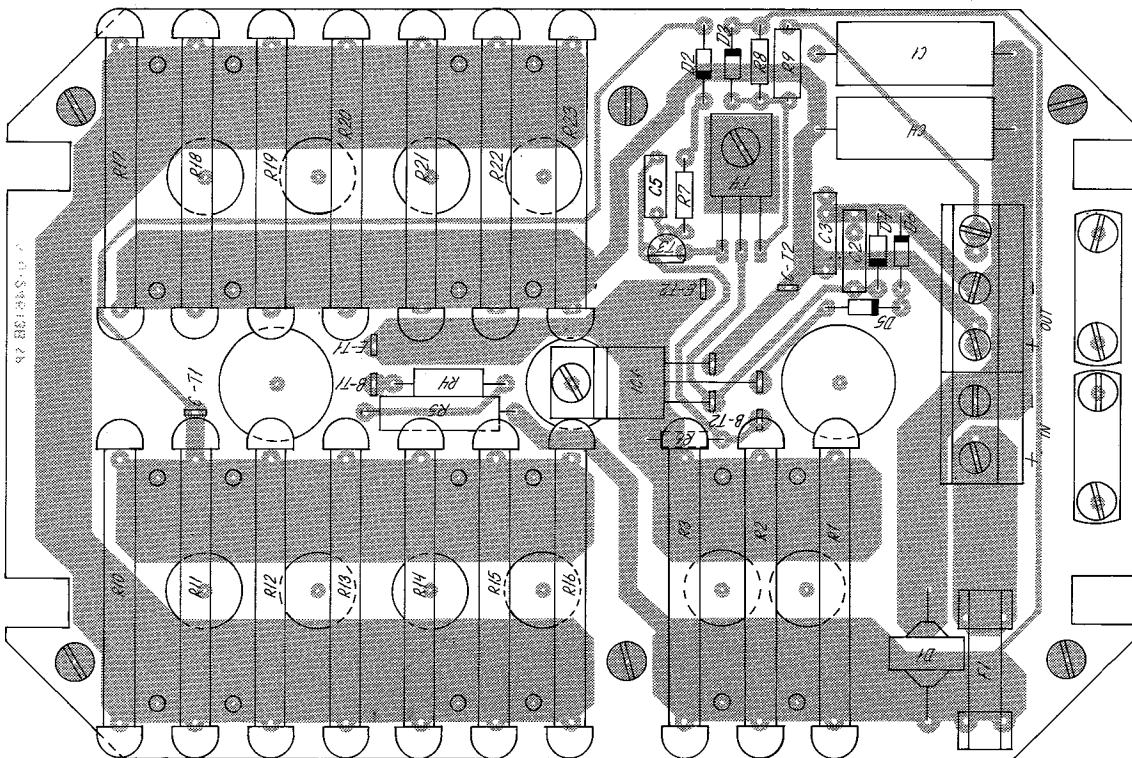

Seen from component side with lower side tracks

5-0-24613

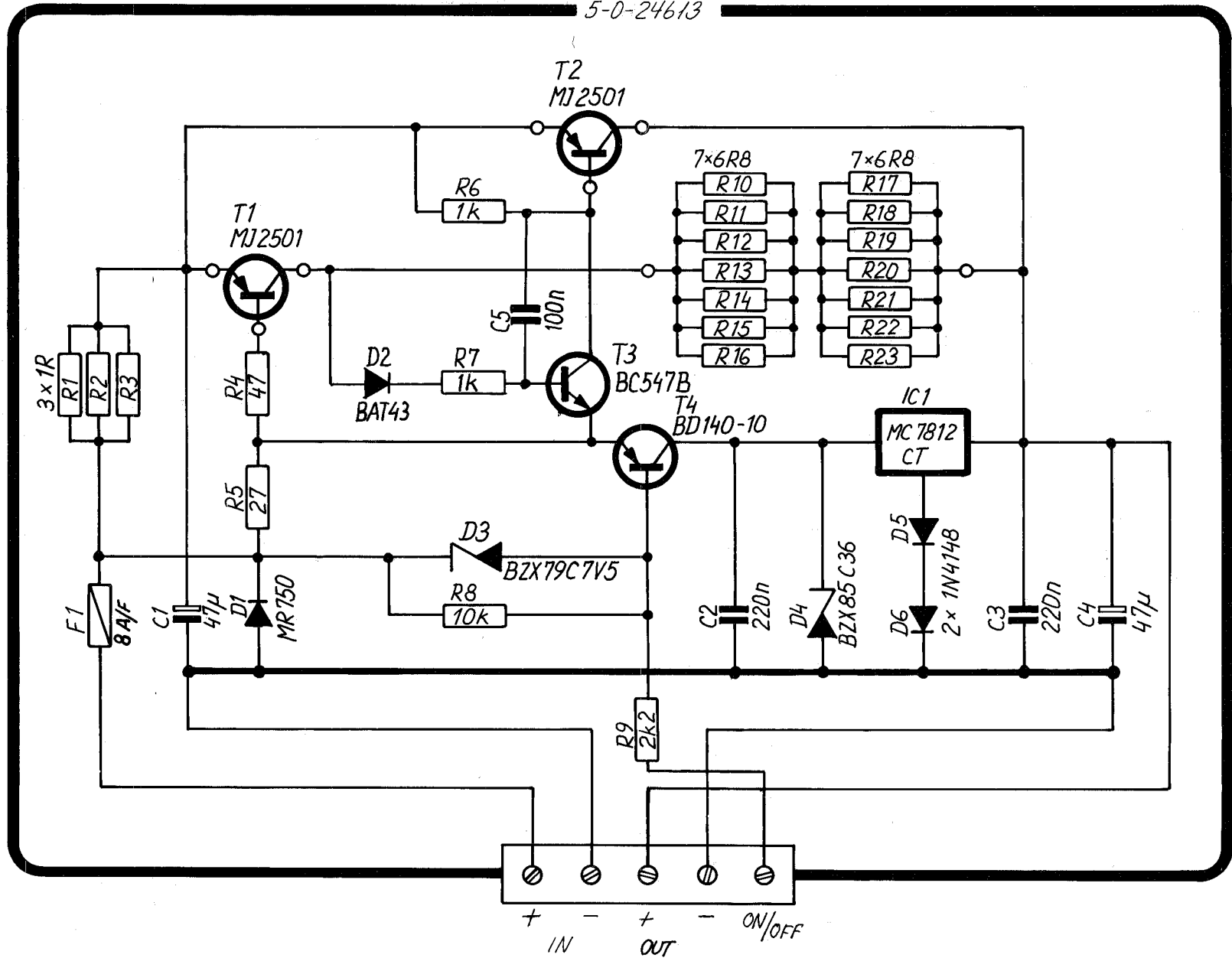

12V VOLTAGE REGULATOR

6 PARTS LIST

HF SSB N2161		POWER SUPPLY AC to 24VDC		SP. RADIO A/S	802161
POSITION	DESCRIPTION		MANUFACTOR	TYPE	PARTNO.
VARIOUS	SMALL COVER T2130			225878 GREEN RILSAN	22587800
VARIOUS	COWER WITH STREAMER N2161		ECI A/S	3-0-25970	225970
VARIOUS	BASE UNIT N2161	N2161	ECI A/S		702161
VARIOUS	LASHING KIT FOR T2130	AND N2160 / N2161	ECI A/S	0-0-26141	726141
VARIOUS	SPARE FUSES FOR N2161		ECI A/S	0-0-26196	726196
VARIOUS	SCREW	M5x10 PHRX-A2	HFC	HFC 1877 M5x10 PHRX-A2 DIN 7985	87.452
VARIOUS	THUMB SCREW M3x5x12	DIN464	O.J.D.	FINGERSKRUE M3x5 DIN464	90.620
VARIOUS	MANUAL N2161 ENGLISH		ECI A/S		M2161GB

BASE UNIT N2161		N2161	ECI A/S		702161
POSITION	DESCRIPTION		MANUFACTOR	TYPE	PARTNO.
VARIOUS	INSULATION WASHER	SILICONE FOIL 18x12x0.18	HAFNIA	TO-220 18x12x0.18mm	30.541
VARIOUS	INSULATION WASHER	SILICONE FOIL 18x12x0.18	HAFNIA	TO-220 18x12x0.18mm	30.541
VARIOUS	INSULATION WASHER	SILICONE FOIL 18x12x0.18	HAFNIA	TO-220 18x12x0.18mm	30.541
-1	CONNECTION/THYRISTOR UNIT	N2161	ECI A/S	5-0-25980A / 4-0-25980A	625980
-2	CONTROL UNIT N1410	MODULE 2	ECI A/S	4-6-24957 / 4-0-24957D	600792
-4	VOLTAGE REGULATOR	N420	ECI A/S	5-0-24613G / 4-0-24613D	600416
C1-3	CAPACITOR ELECTROLYTIC	10000uF -10/+50% 63VDC	ERO	EY 02 DF 510 J & U8 DIN 41331	14.870
C2-3	CAPACITOR ELECTROLYTIC	10000uF -10/+50% 63VDC	ERO	EY 02 DF 510 J & U8 DIN 41331	14.870
C3-3	CAPACITOR ELECTROLYTIC	10000uF -10/+50% 63VDC	ERO	EY 02 DF 510 J & U8 DIN 41331	14.870
C4-3	CAPACITOR ELECTROLYTIC	10000uF -10/+50% 63VDC	ERO	EY 02 DF 510 J & U8 DIN 41331	14.870
C5-3	CAPACITOR ELECTROLYTIC	10000uF -10/+50% 63VDC	ERO	EY 02 DF 510 J & U8 DIN 41331	14.870
D1-3	DIODE POW.RECT.35A/100VDC	1N1184R/BYX52-300R	INT.RECTIFIER	1N1184R INCL.HARDWARE (1N1185R,-86R,-,90R)	25.165
IC3-2	POS. VOLTAGE REG. 15V/1A	MC7815, LM340T-15	MOTOROLA	MC7815CT (MC7815BT)	31.090
L1-3	CHOKER 2mH/20ADC		KOHSEL	Art. Nr. 96/58-5290 6-0-31838	22.185
Q1-(4)	TRANSISTOR DARLINGTON	MJ2501	MOTOROLA	MJ2501	29.235
Q2-(4)	TRANSISTOR DARLINGTON	MJ2501	MOTOROLA	MJ2501	29.235
TR1-3	TRANSFORMER MAINS	1k3VA N2161	KOHSEL	Art. Nr.: U1120/40-5281 6-0-31833	22.509

CONNECTION/THYRISTOR UNIT		N2161	ECI A/S	5-0-25980A / 4-0-25980A	625980
POSITION	DESCRIPTION		MANUFACTOR	TYPE	PARTNO.
VARIOUS	FUSE CLIP	1/4" PCB TYPE	LITTELFUSE	102 071	78.389
C1-1	CAPACITOR MKT	2.2uF 5% 63V	ERO	MKT1822	11.141
D1-1	DIODE DUAL 2x10A/300VDC	TO-220 BYV34-300	PHILIPS	BYV34-300 (-400-500)	27.158
D2-1	DIODE DUAL 2x10A/300VDC	TO-220 BYV34-300	PHILIPS	BYV34-300 (-400-500)	27.158
D3-1	DIODE HIGH SPEED	1N4448	PHILIPS	1N4448	25.147
D4-1	DIODE HIGH SPEED	1N4448	PHILIPS	1N4448	25.147
D5-1	DIODE HIGH SPEED	1N4448	PHILIPS	1N4448	25.147
F1/220V	FUSE	8AM ø6.3x32mm	LITTELFUSE	311008	45.628
F1/110V	FUSE	15AM ø6.3x32mm	LITTELFUSE	311015	45.630
F2/220V	FUSE	8AM ø6.3x32mm	LITTELFUSE	311008	45.628
F2/110V	FUSE	15AM ø6.3x32mm	LITTELFUSE	311015	45.630
P1-1	CONNECTION ELEMENT	FOR M5 SCREW	ESPERA	1-0-25860	225860
P2-1	CONNECTION ELEMENT	FOR M5 SCREW	ESPERA	1-0-25860	225860
P3-1	CONNECTION ELEMENT	FOR M5 SCREW	ESPERA	1-0-25860	225860
P4-1	CONNECTION ELEMENT	FOR M5 SCREW	ESPERA	1-0-25860	225860
P5-1	PLUG (MALE)	11 POLE	AMP	1-826375-1	78.111
P6-1	CONNECTION ELEMENT	FOR M5 SCREW	ESPERA	1-0-25860	225860
P7-1	CONNECTION ELEMENT	FOR M5 SCREW	ESPERA	1-0-25860	225860
P8-1	CONNECTION ELEMENT	FOR M5 SCREW	ESPERA	1-0-25860	225860
P9-1	CONNECTION ELEMENT	FOR M5 SCREW	ESPERA	1-0-25860	225860
Q1-1	SCR 200V/40A rms TO-220	S4014BH/S4012BH	TAG	S4014BH (S4014 DH/MH/NM)	29.930
Q2-1	SCR 200V/40A rms TO-220	S4014BH/S4012BH	TAG	S4014BH (S4014 DH/MH/NM)	29.930
R1-1	RESISTOR	47m OHM 5% 0.6W	MODULOHM I/S	98247/47U-J-MI-A-1	06.233
R2-1	RESISTOR	47m OHM 5% 0.6W	MODULOHM I/S	98247/47U-J-MI-A-1	06.233
R3-1	RESISTOR	47m OHM 5% 0.6W	MODULOHM I/S	98247/47U-J-MI-A-1	06.233
R4-1	RESISTOR	47m OHM 5% 0.6W	MODULOHM I/S	98247/47U-J-MI-A-1	06.233
R5-1	RESISTOR	47m OHM 5% 0.6W	MODULOHM I/S	98247/47U-J-MI-A-1	06.233
ST1-1	TERMINAL BLOCK	3 POLES 2.5mm ²	PTR	AK110/3DS m.MESS.SKRUER	81.037

6 PARTS LIST

N2161

POSITION	DESCRIPTION		MANUFACTURER	TYPE	PART NO.
ST2-1	TERMINAL BLOCK	2 POLES 2.5mm ²	PTR	AK110/2DS m.MESS.SKRUER	81.035
ST3-1	TERMINAL BLOCK	3 POLES 2.5mm ²	PTR	AK110/3DS m.MESS.SKRUER	81.037
ST4-1	TERMINAL BLOCK	4 POLES 2.5mm ²	PTR	AK110/4DS m.MESS.SKRUER	81.038

CONTROL UNIT N1410	MODULE 2	ECI A/S	4-6-24957 / 4-0-24957D	600792
--------------------	----------	---------	------------------------	--------

POSITION	DESCRIPTION		MANUFACTURER	TYPE	PART NO.
C1-2	CAPACITOR ELECTROLYTIC	470uF -20/+50% 40VDC	ERO	EKM 05 FG 347 G 05	14.650
C2-2	CAPACITOR MKT	470nF 10% 100V	SIEMENS	B32510-D1474-K000	11.231
C3-2	CAPACITOR ELECTROLYTIC	10uF 20% 35VDC	ELNA	RJ2-35-V-100-M-T34(T58)	14.512
C4-2	CAPACITOR ELECTROLYTIC	47uF 20% 25VDC	ELNA	RJ2-25-V-470-M-F1	14.524
C5-2	CAPACITOR MKT	1uF 10% 63V	ERO	MKT 1818-510/06 5-G	11.138
C6-2	CAPACITOR MKT	15nF 10% 400V	SIEMENS	B32520-B6153-K000	11.364
C7-2	CAPACITOR MKT	15nF 10% 400V	SIEMENS	B32520-B6153-K000	11.364
C8-2	CAPACITOR MKT	1uF 10% 63V	ERO	MKT 1818-510/06 5-G	11.138
C9-2	CAPACITOR MKT	1uF 10% 63V	ERO	MKT 1818-510/06 5-G	11.138
C10-2	CAPACITOR ELECTROLYTIC	10uF 20% 35VDC	ELNA	RJ2-35-V-100-M-T34(T58)	14.512
C11-2	CAPACITOR ELECTROLYTIC	0.22uF 20% 50VDC	ELNA	RJ2-50V-R22-M-T34	14.502
D1-2	DIODE RECTIFIER	1N4002 100V/1A	MOTOROLA	1N4002(03/04/05/06/07)RL	25.100
D2-2	DIODE RECTIFIER	1N4002 100V/1A	MOTOROLA	1N4002(03/04/05/06/07)RL	25.100
D3-2	DIODE RECTIFIER	1N4002 100V/1A	MOTOROLA	1N4002(03/04/05/06/07)RL	25.100
D4-2	DIODE RECTIFIER	1N4002 100V/1A	MOTOROLA	1N4002(03/04/05/06/07)RL	25.100
D5-2	DIODE RECTIFIER	1N4002 100V/1A	MOTOROLA	1N4002(03/04/05/06/07)RL	25.100
D6-2	DIODE ZENER	5.1V 5% 0.4W BZX79C5V1	PHILIPS	BZX79C5V1	26.527
D7-2	DIODE	1N4148 HIGH SPEED	PHILIPS	1N4148-143	25.131
D8-2	DIODE	1N4148 HIGH SPEED	PHILIPS	1N4148-143	25.131
D9-2	DIODE	1N4148 HIGH SPEED	PHILIPS	1N4148-143	25.131
D10-2	DIODE	1N4148 HIGH SPEED	PHILIPS	1N4148-143	25.131
D11-2	DIODE	1N4148 HIGH SPEED	PHILIPS	1N4148-143	25.131
D12-2	DIODE	1N4148 HIGH SPEED	PHILIPS	1N4148-143	25.131
D13-2	DIODE	1N4148 HIGH SPEED	PHILIPS	1N4148-143	25.131
D14-2	DIODE	1N4148 HIGH SPEED	PHILIPS	1N4148-143	25.131
D15-2	DIODE ZENER	2V7 5% 0.4W BZX79C2V7	PHILIPS	BZX79C2V7	26.506
D16-2	DIODE	1N4148 HIGH SPEED	PHILIPS	1N4148-143	25.131
D17-2	DIODE RECTIFIER	1N4002 100V/1A	MOTOROLA	1N4002(03/04/05/06/07)RL	25.100
D18-2	DIODE ZENER	18V 5% 0.4W BZX79C18	PHILIPS	BZX79C18	26.564
D19-2	DIODE RECTIFIER	1N4002 100V/1A	MOTOROLA	1N4002(03/04/05/06/07)RL	25.100
D20-2	DIODE RECTIFIER	1N4002 100V/1A	MOTOROLA	1N4002(03/04/05/06/07)RL	25.100
D21-2	DIODE ZENER	5V6 5% 0.4W BZX79C5V6	PHILIPS	BZX79C5V6	26.530
IC1-2	DUAL OP AMP	LM358N	MOTOTOLA	LM 358N REDESIGNES/931122/JH-MOT	31.100
IC2-2	DUAL OP AMP	LM358N	MOTOTOLA	LM 358N REDESIGNES/931122/JH-MOT	31.100
P1-2	PLUG (MALE)	9 POLE	AMP	0-826375-9	78.109
P2-2	PLUG (MALE)	4 POLE	AMP	0-826375-4	78.104
R1-2	RESISTOR	11 KOHM 1% 0.4W	PHILIPS	2322 156 11103	03.458
R2-2	RESISTOR	11 KOHM 1% 0.4W	PHILIPS	2322 156 11103	03.458
R3-2	RESISTOR MF	1k6 OHM 5% 0.4W	PHILIPS	2322 181 53162	01.205
R4-2	RESISTOR MF	10 OHM 5% 0.4W	PHILIPS	2322 181 53109	01.150
R5-2	RESISTOR MF	1k00 OHM 1% 0.4W	PHILIPS	2322 156 11002	03.395
R6-2	RESISTOR MF	10k OHM 5% 0.4W	PHILIPS	2322 181 53103	01.225
R7-2	RESISTOR MF	1k0 OHM 5% 0.4W	PHILIPS	2322 181 53102	01.200
R8-2	RESISTOR MF	1k00 OHM 1% 0.4W	PHILIPS	2322 156 11002	03.395
R9-2	RESISTOR MF	10k OHM 5% 0.4W	PHILIPS	2322 181 53103	01.225
R10-2	RESISTOR MF	27k OHM 5% 0.4W	PHILIPS	2322 181 53273	01.235
R11-2	RESISTOR MF	1k8 OHM 5% 0.4W	PHILIPS	2322 181 53182	01.206
R12-2	RESISTOR MF	820 OHM 5% 0.4W	PHILIPS	2322 181 53821	01.197
R13-2	POTENTIOMETER TRIMMING	2.2 KOHM 10% 0.5W	PHILIPS	2322 484 75222	07.665
R14-2	RESISTOR MF	4k7 OHM 5% 0.4W	PHILIPS	2322 181 53472	01.216
R15-2	RESISTOR MF	3k3 OHM 5% 0.4W	PHILIPS	2322 181 53332	01.212
R16-2	RESISTOR MF	3k3 OHM 5% 0.4W	PHILIPS	2322 181 53332	01.212
R17-2	RESISTOR MF	1M0 OHM 5% 0.4W	PHILIPS	2322 181 53105	01.275
R18-2	RESISTOR MF	10k OHM 5% 0.4W	PHILIPS	2322 181 53103	01.225
R19-2	RESISTOR MF	1k0 OHM 5% 0.4W	PHILIPS	2322 181 53102	01.200
R20-2	RESISTOR MF	68k OHM 5% 0.4W	PHILIPS	2322 181 53683	01.245
R21-2	RESISTOR MF	6k8 OHM 5% 0.4W	PHILIPS	2322 181 53682	01.220
R22-2	RESISTOR MF	10k OHM 5% 0.4W	PHILIPS	2322 181 53103	01.225
R23-2	RESISTOR MF	6k8 OHM 5% 0.4W	PHILIPS	2322 181 53682	01.220
R24-2	RESISTOR MF	1k0 OHM 5% 0.4W	PHILIPS	2322 181 53102	01.200
R25-2	RESISTOR MF	10k OHM 5% 0.4W	PHILIPS	2322 181 53103	01.225
R26-2	RESISTOR MF	1k0 OHM 5% 0.4W	PHILIPS	2322 181 53102	01.200
R27-2	RESISTOR MF	4k7 OHM 5% 0.4W	PHILIPS	2322 181 53472	01.216
R28-2	RESISTOR MF	2k7 OHM 5% 0.4W	PHILIPS	2322 181 53272	01.210

PAGE 6-2

9727

6 PARTS LIST

N2161

POSITION	DESCRIPTION		MANUFACTURER	TYPE	PART NO.
R29-2	RESISTOR MF	100k OHM 5% 0.4W	PHILIPS	2322 181 53104	01.250
R30-2	RESISTOR MF	4k7 OHM 5% 0.4W	PHILIPS	2322 181 53472	01.216
R31-2	RESISTOR MF	39 OHM 5% 0.4W	PHILIPS	2322 181 53399	01.164
R32-2	RESISTOR MF	10 OHM 5% 0.4W	PHILIPS	2322 181 53109	01.150
R33-2	RESISTOR	1 MOHM 1% 0.4W	PHILIPS	2322 156 11005	03.604
R34-2	RESISTOR MF	100 OHM 5% 0.4W	PHILIPS	2322 181 53101	01.175
R35-2	RESISTOR MF	100 OHM 5% 0.4W	PHILIPS	2322 181 53101	01.175
R36-2	RESISTOR	30 KOHM 1% 0.4W	PHILIPS	2322 156 13003	03.460
R37-2	RESISTOR MF	1k00 OHM 1% 0.4W	PHILIPS	2322 156 11002	03.395
R38-2	RESISTOR	30 KOHM 1% 0.4W	PHILIPS	2322 156 13003	03.460
R39-2	RESISTOR	1 MOHM 1% 0.4W	PHILIPS	2322 156 11005	03.604
R40-2	RESISTOR MF	10 OHM 5% 0.4W	PHILIPS	2322 181 53109	01.150
R41-2	RESISTOR MF	1k00 OHM 1% 0.4W	PHILIPS	2322 156 11002	03.395
R42-2	RESISTOR MF	1k2 OHM 5% 0.4W	PHILIPS	2322 181 53122	01.202
R43-2	RESISTOR MF	1k8 OHM 5% 0.4W	PHILIPS	2322 181 53182	01.206
R44-2	POTENTIOMETER TRIMMING	1 KOHM 10% 0.5W	PHILIPS	2322 484 75102	07.660
R45-2	RESISTOR MF	82 OHM 5% 0.4W	PHILIPS	2322 181 53829	01.172
T1-2	TRANSISTOR AF	BC547B NPN TO-92	PHILIPS	BC547B-126	28.067
T2-2	TRANSISTOR AF	BC547B NPN TO-92	PHILIPS	BC547B-126	28.067
T3-2	TRANSISTOR AF	BC547B NPN TO-92	PHILIPS	BC547B-126	28.067
T4-2	TRANSISTOR AF	BC547B NPN TO-92	PHILIPS	BC547B-126	28.067
T5-2	TRANSISTOR AF	BC547B NPN TO-92	PHILIPS	BC547B-126	28.067
T6-2	TRANSISTOR AF	BC338-25 NPN TO-92	PHILIPS	BC338-25-126 (BC337-25-126)	28.058
TR1-2	TRANSFORMER	3:1:1	SCHAFFNER	IT 244	22.000

VOLTAGE REGULATOR	N420	ECI A/S	5-0-24613G / 4-0-24613D	600416
-------------------	------	---------	-------------------------	--------

POSITION	DESCRIPTION		MANUFACTURER	TYPE	PART NO.
C1	CAPACITOR ELECTROLYTIC	47uF -10/+50% 63V	NATIONAL	ECEB 1JV 470S	14.552
C2	CAPACITOR MKT	220nF 10% 63VDC	ERO	MKT 1818-422/06 5-G 1818422065	11.090
C3	CAPACITOR MKT	220nF 10% 63VDC	ERO	MKT 1818-422/06 5-G 1818422065	11.090
C4	CAPACITOR ELECTROLYTIC	47uF -10/+50% 63V	NATIONAL	ECEB 1JV 470S	14.552
C5	CAPACITOR MKT	100nF 10% 100VDC	ERO	MKT 1818-410/01 5-G	11.180
D1	DIODE RECTIFIER 50V/6ADC	MR750, RL750	MOTOROLA	MR750 (51,52,54,56,60)	25.219
D2	DIODE SCHOTTKY	BAT 43	THOMSON-CSF	BAT43	27.600
D3	DIODE ZENER	7.5V 5% 0.4W BZX79C7V5	PHILIPS	BZX79C7V5	26.539
D5	DIODE	1N4148 HIGH SPEED	PHILIPS	1N4148-143	25.131
D6	DIODE	1N4148 HIGH SPEED	PHILIPS	1N4148-143	25.131
F1	FUSE	8AF 250V *5x20mm	LITTEL FUSE	217008, TYPE EA	45.561
IC1	POS. VOLTAGE REG. 12V/1A	MC7812-LM340T-12	MOTOROLA	MC7812CT (MC7812BT)	31.260
R1	RESISTOR POWER	1R0 OHM 10% 6.5W	VITROHM	1R0 10% TYPE 296-0	05.725
R2	RESISTOR POWER	1R0 OHM 10% 6.5W	VITROHM	1R0 10% TYPE 296-0	05.725
R3	RESISTOR POWER	1R0 OHM 10% 6.5W	VITROHM	1R0 10% TYPE 296-0	05.725
R4	RESISTOR	47 OHM 5% 0.6W	BEYSCHLAG	MBB 0207-00-BX-47R 5%	03.167
R5	RESISTOR PMF	27 OHM 5% 3W	PHILIPS	2322 195 13279	04.660
R6	RESISTOR MF	1k0 OHM 5% 0.4W	PHILIPS	2322 181 53102	01.200
R7	RESISTOR MF	1k0 OHM 5% 0.4W	PHILIPS	2322 181 53102	01.200
R8	RESISTOR MF	10k OHM 5% 0.4W	PHILIPS	2322 181 53103	01.225
R9	RESISTOR	2.2 KOHM 5% 0.6W	DRALORIC	SMA 0207 S TK100-2K2 5%	03.208
R10	RESISTOR POWER	6R8 OHM 10% 6.5W	VITROHM	6R8 10% TYPE 296-0	05.730
R11	RESISTOR POWER	6R8 OHM 10% 6.5W	VITROHM	6R8 10% TYPE 296-0	05.730
R12	RESISTOR POWER	6R8 OHM 10% 6.5W	VITROHM	6R8 10% TYPE 296-0	05.730
R13	RESISTOR POWER	6R8 OHM 10% 6.5W	VITROHM	6R8 10% TYPE 296-0	05.730
R14	RESISTOR POWER	6R8 OHM 10% 6.5W	VITROHM	6R8 10% TYPE 296-0	05.730
R15	RESISTOR POWER	6R8 OHM 10% 6.5W	VITROHM	6R8 10% TYPE 296-0	05.730
R16	RESISTOR POWER	6R8 OHM 10% 6.5W	VITROHM	6R8 10% TYPE 296-0	05.730
R17	RESISTOR POWER	6R8 OHM 10% 6.5W	VITROHM	6R8 10% TYPE 296-0	05.730
R18	RESISTOR POWER	6R8 OHM 10% 6.5W	VITROHM	6R8 10% TYPE 296-0	05.730
R19	RESISTOR POWER	6R8 OHM 10% 6.5W	VITROHM	6R8 10% TYPE 296-0	05.730
R20	RESISTOR POWER	6R8 OHM 10% 6.5W	VITROHM	6R8 10% TYPE 296-0	05.730
R21	RESISTOR POWER	6R8 OHM 10% 6.5W	VITROHM	6R8 10% TYPE 296-0	05.730
R22	RESISTOR POWER	6R8 OHM 10% 6.5W	VITROHM	6R8 10% TYPE 296-0	05.730
R23	RESISTOR POWER	6R8 OHM 10% 6.5W	VITROHM	6R8 10% TYPE 296-0	05.730
T1	TRANSISTOR DARLINGTON	MJ2501	MOTOROLA	MJ2501	29.235
T2	TRANSISTOR DARLINGTON	MJ2501	MOTOROLA	MJ2501	29.235
T3	TRANSISTOR AF	BC547B NPN TO-92	PHILIPS	BC547B-126	28.067
T4	TRANSISTOR	BD140-10	PHILIPS	BD140-10	29.066