

# Sailor

# Sailor

**INSTRUKTIONSBOG FOR  
SAILOR N 1400**

**INSTRUCTION BOOK FOR  
SAILOR N 1400**



**A/S S. P. RADIO · AALBORG · DENMARK**

## CONTENTS:

GENERAL DESCRIPTION .....	2
TECHNICAL DATA .....	3
CONTROLS .....	4
PRINCIPLE OF OPERATION .....	5
SERVICE:	
1. MAINTENANCE .....	6
2. NECESSARY TEST EQUIPMENT .....	7
3. TROUBLE-SHOOTING .....	11
4. PERFORMANCE CHECK FOR N1400 .....	12
5. ADJUSTMENT PROCEDURE FOR N1400 .....	15
6. NECESSARY ADJUSTMENTS AFTER REPAIR FOR N1400 .....	15
7. FUNCTION CHECK N1400 .....	16
PIN CONFIGURATIONS .....	17
CIRCUIT DESCRIPTION .....	18
ADJUSTMENT LOCATIONS AND SCHEMATIC DIAGRAMS	
PARTS LIST	
MAIN SCHEMATIC DIAGRAM	

SAILOR N1400

## GENERAL DESCRIPTION

SAILOR N1400 is a DC power supply intended to supply a SAILOR SSB short-wave set, when the set has to be supplied from a 24V battery.

SAILOR N1400 has a MAIN SWITCH which controls all power supply to the short-wave set. All fuses for the short-wave set are located behind the AIR FILTER.

SAILOR N1400 has a built-in delay unit which ensures the proper sequence for applying voltages to the transmitter, regardless of how the MAIN SWITCH is operated.

SAILOR N1400 with MAIN SWITCH in position RECEIVER ONLY. Only the receiver is supplied and low power consumption is achieved.

SAILOR N1400 with MAIN SWITCH in position STAND BY, filament and negative bias are supplied to the transmitter.

SAILOR N1400 has a meter which controls the input voltage. A switch behind the AIR FILTER makes it possible with the same meter to check the voltages inside the set.

SAILOR N1400 is provided with thermal breakers which switch off the set, if the temperature inside the power supply gets too high.

SAILOR N1400 has a built-in loudspeaker for the connected receiver.

SAILOR N1400 fits into SAILOR 19" rack system.

# TECHNICAL DATA

The power supply N1400 delivers all necessary voltages to a SAILOR SSB short wave set with an output power of 800 W PEP in the frequencies range 4 - 27.5 MHz. In the frequency range 1.6 - 4 MHz the plate voltage is reduced in order to limit the output power to 400 W PEP. When N1400 is used for 405 - 535 kHz transmitters the plate voltage is the same as when the frequency range is 4 - 27.5 MHz.

Input voltage: Normal voltage 26.5V DC  $\pm 10\%$

Input current:

Input current (24V DC)	1.6 - 4 MHz	4 - 27.5 MHz
Receiver only	1.8A	1.8A
Stand by	8.2A	8.2A
On	9.0A	9.0A
Tune (full PEP 2-tone)	41A	55A
SSB Normal Speech	34A	43A
A3H Normal Speech	40A	52A
A2H telegraphy Key up/down	19/41	21/55
A1 telegraphy Key up/down	19/49	21/68

Output voltages:

DC unstabilized

Va 1.4/2 KV  
 Vfilament =input  
 -45V -45V

DC stabilized

Vdriver 28V  $\pm 5\%$   
 Vg1 -60V  $\pm 5\%$   
 22V 22V  $\pm 2\%$   
 \* 8V 8V  $\pm 5\%$   
 2xVg2 400V  $\pm 2\%$

The currents from Vg2's are limited to protect the screen in the PA tubes.

AC unstabilized

Blower supply 50 - 60 Hz

Operation temperature range:  $-15^{\circ}\text{C}$  to  $+55^{\circ}\text{C}$

Cooling:

With MAIN SWITCH in position STAND BY and ON the internal blower is running. If the inside temperature gets too high thermal breakers disconnect the 22V and stop the set until it has cooled down.

When MAIN SWITCH is in position RECEIVER ONLY and the internal temperature exceeds  $+55^{\circ}\text{C}$  the internal blower starts automatically, when the temperature falls below  $+40^{\circ}\text{C}$  the blower stops. (Valid for power supplies N1400 with serial number higher than 173759).

\* Power supplies N1400 with a serial number below 174144 do not have the 8V supply.

SAILOR N1400



## CONTROLS

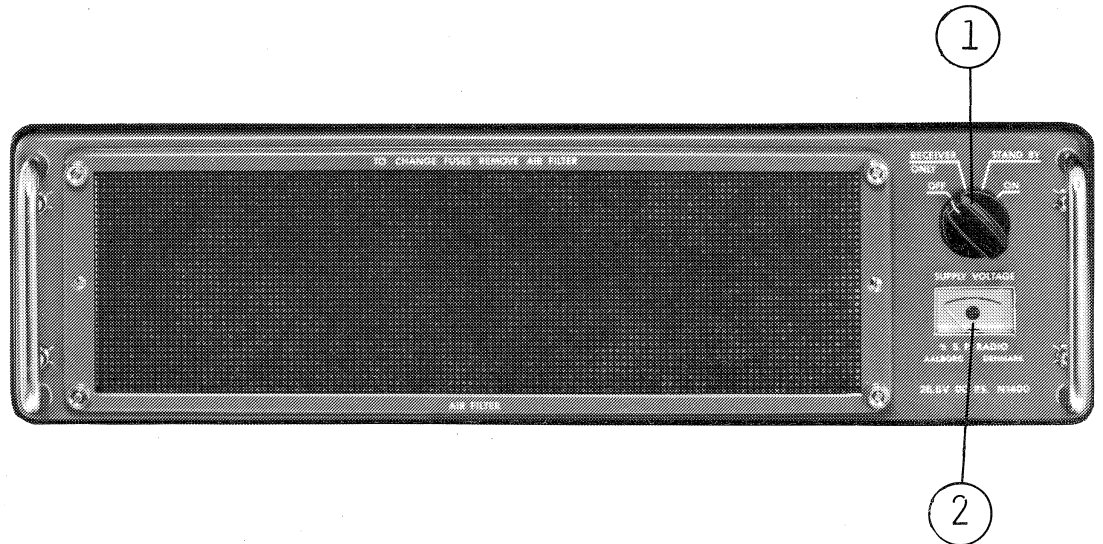

### ① MAIN SWITCH

Switching between the functions.

#### OFF

The set is switched off.

#### RECEIVER ONLY

The receiver is supplied with power and ready for use.

#### STAND BY

Internal blower starts and voltages are supplied to the transmitter in order to make it ready for use.

#### ON

The transmitter is ready for use if it has been in position STAND BY or ON for a period equal to or longer than the delay time.

### ② SUPPLY VOLTAGE METER

Meter checking the input voltage to the set. Internal voltage check, by using the switch located behind the AIR FILTER it is possible to check different voltages in the set.

# PRINCIPLE OF OPERATION N1400

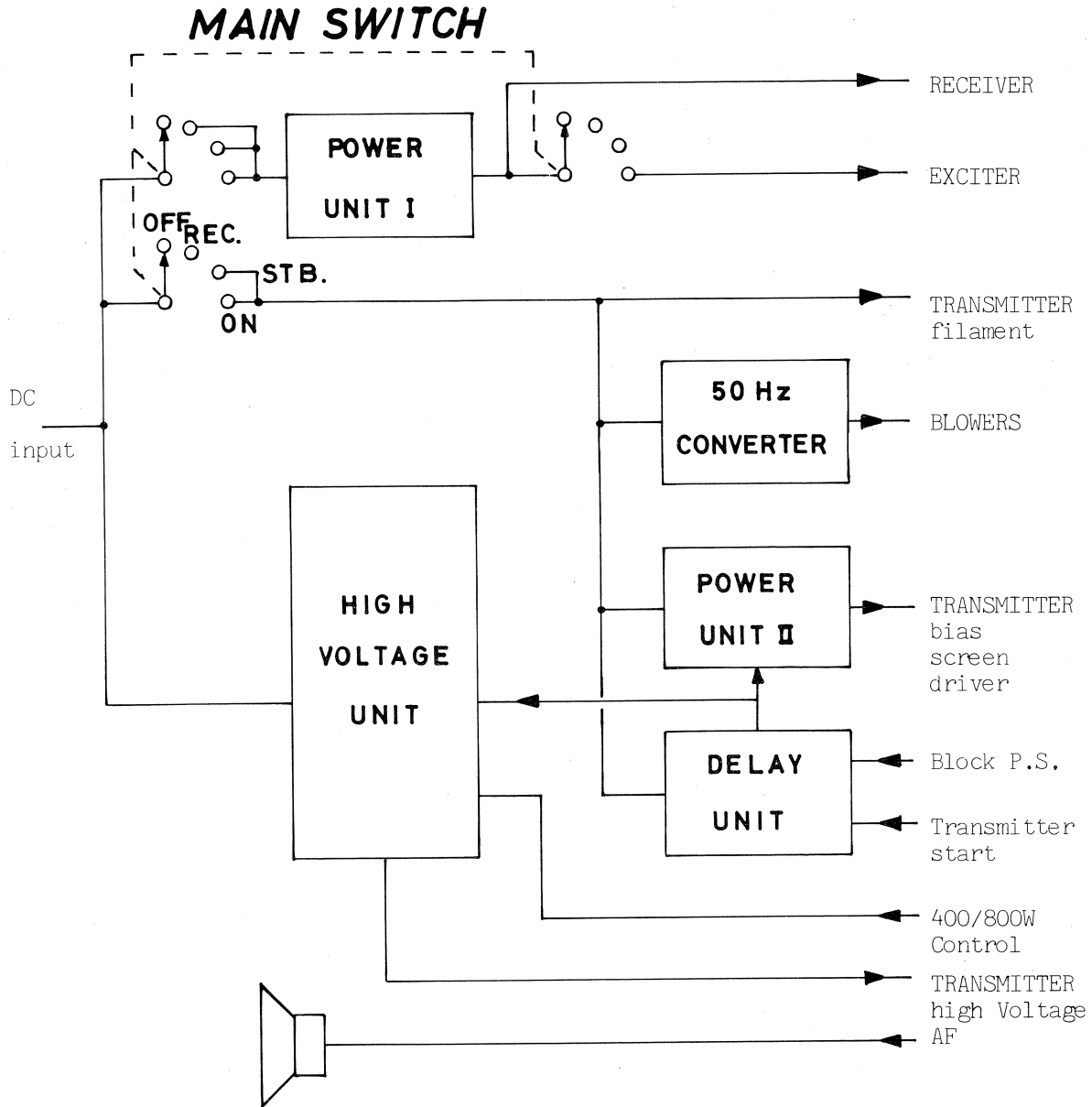

SAILOR N1400

## POWER SUPPLY N1400

The function of the power supply is controlled from MAIN SWITCH, DELAY UNIT and the control inputs Transmitter start and Block P.S.

POWER UNIT I is connected in positions RECEIVER ONLY, STAND BY and ON. It supplies the RECEIVER and the EXCITER. The EXCITER in position ON only.

POWER UNIT II is connected in positions STAND BY and ON. The output bias is present, whereas the outputs screen and driver follows the Transmitter start control input if the power supply N1400 is not blocked via the control input Block P.S.

50 Hz CONVERTER is connected in positions STAND BY and ON, the internal blower runs and AC is supplied to the transmitter blower.

HIGH VOLTAGE UNIT is only in function in position ON when the control inputs Transmitter start and Block P.S. are present. The size of the HIGH VOLTAGE is controlled via the control input 400/800W Control.

DELAY UNIT is started in position STAND BY and runs in STAND BY and ON while filament is supplied to the transmitter tubes. After the delay time, the control inputs Transmitter start and Block P.S. are allowed to pass through the DELAY UNIT.

## SERVICE

1. MAINTENANCE
2. NECESSARY TEST EQUIPMENT
3. TROUBLE-SHOOTING
4. PERFORMANCE CHECK
5. ADJUSTMENT PROCEDURE
6. NECESSARY ADJUSTMENTS AFTER REPAIR
7. FUNCTION CHECK

### 1. MAINTENANCE

#### 1.1.

When the SAILOR SHORT WAVE SET type 1000 has been correctly installed, the maintenance can, dependent on the environment and working hours, be reduced to a performance check at the service workshop at intervals not exceeding 5 years. A complete performance check list is enclosed in the PERFORMANCE CHECK section.

Also inspect the antennae, cables and plugs for mechanical defects, salt deposits, corrosion and any foreign bodies.

Along with each set a TEST SHEET is delivered, in which some of the measurements made at the factory are listed. If the performance check does not show the same values as those on the TEST SHEET, the set must be adjusted as described under ADJUSTMENT PROCEDURE.

Any repair of the set should be followed by a FUNCTION CHECK of the unit in question.

## 2. NECESSARY TEST EQUIPMENT

T1127	N140X	S1300	R1117	
X	X	X	X	<u>OSCILLOSCOPE:</u> Bandwidth 0-25 MHz Sensitivity 2mV/cm Input impedance 1 Mohm//30 pF Triggering EXT-INT-ENVELOPE E.g. PHILIPS PM3212
X		X	X	<u>PASSIVE PROBE:</u> Attenuation 10x Input resistance DC 10 Mohm Input capacitance 15 pF Compensation range 10 pF - 30 pF E.g. PHILIPS PM 9396
		X	X	<u>MULTIMETER:</u> Sensitivity (f.s.d.) 1V Input impedance 10 Mohm Accuracy (f.s.d.) +2% E.g. PHILIPS PM2503
X	X			<u>MULTIMETER:</u> Sensitivity 0.3V and 3A Input impedance 30 Kohm/V Accuracy (F.S.d.) +1% Current range 100A Voltage range 500V, and 2.5 kV E.g. Unigor A43, with probe and shunt

SAILOR N1400  
1/5

NECESSARY TEST EQUIPMENT cont.:

SAILOR N1400  
A 2/5

T1127	N140X	S1300	R1117
		X	
			X
		X	X
			X

TONEGENERATOR:

Frequency range 200 - 3000 Hz  
 Output 1V RMS  
 Output impedance  $\leq 600$  ohm  
 E.g. PHILIPS PM5107

AF VOLTMETER:

Sensitivity (f.s.d.) 300 mV  
 Input impedance  $\geq 4$  ohm  
 Accuracy (f.s.d.)  $\pm 5$  %  
 Frequency range 100 Hz - 5 kHz  
 E.g. PHILIPS PM2503

FREQUENCY COUNTER:

Frequency range 100 Hz - 40 MHz  
 Resolution 0,1 Hz at  $f \geq 10$  MHz  
 Accuracy  $1 \cdot 10^{-7}$   
 Sensitivity 100 mV RMS  
 Input impedance 1 Mohm  
 Single period measurement range 1 sec.  
 resolution 1 mS  
 E.g. PHILIPS PM6611 + PM9679

SIGNAL GENERATOR

Frequency range 550 kHz - 30 MHz  
 R1118: 100 kHz - 30 MHz  
 Output impedance 50/75 ohm  
 Output voltage 1 uV - 100 mV EMF  
 Modulation AM, 30%, 1000 Hz  
 E.g. PHILIPS PM5326

NECESSARY TEST EQUIPMENT cont.:

T1127	N140X	S1300	R1117
X			
		X	X
		X	
X			
X		X	

POWER SUPPLIES

T1127:

V<sub>out</sub> 26,5V DC  
 I<sub>out</sub> 60A DC  
 E.g. 2 pcs. LAMBDA type LMG24

R1117/S1300:

V<sub>out</sub> 1 22V  
 I<sub>out</sub> 1 1,5A  
 V<sub>out</sub> 2 -45V  
 I<sub>out</sub> 2 0,2A  
 E.g. SAILOR POWER SUPPLY type N1402

TEST BOX S1300:

SP type S1300/01 TEST BOX

POWER METER:

Power range 500W  
 E.g. Bird Thruline Wattmeter Model 43  
 plug-in element 500W 2-30 MHz  
 impedance 50 ohm

RF-AMMETER (Thermocross)

Current range 5A  
 E.g. HELWEG MIKKELSEN & CO. Copenhagen, Denmark  
 type TR-68x71 5A

DUMMY LOAD for HF bands, 4 MHz to 25 MHz

Impedance 50 ohm  
 Frequency range 0-25 MHz  
 Power range 500W  
 E.g. BIRD Termaline Coaxial resistor Model 8401

SAILOR N1400  
A 3/5



SAILOR N1400  
A 4/5

T1127	N140X	S1300	R1117
X			

DUMMY LOAD for C.T. band 1.6 MHz to 4 MHz

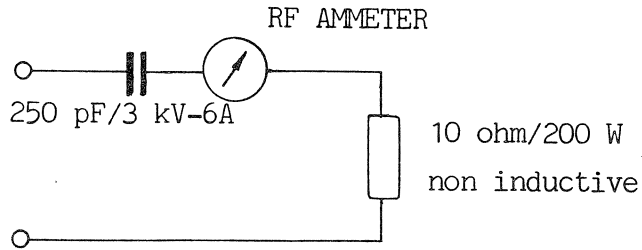

250 pF

E.g. DRALORIC 06 1291 TD 20x50 L

8 KV<sub>S</sub> 250 pF  $\pm 20\%$  R85

10 ohm

E.g. 10 pcs. DALE PH-25A-17, 100 ohm 5% 25W

X DUMMY LOAD for the C.T. band 1.6 to 4 MHz

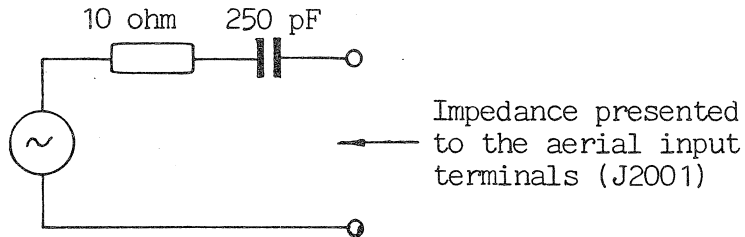

X DUMMY LOAD for the HF bands 4 MHz to 25 MHz

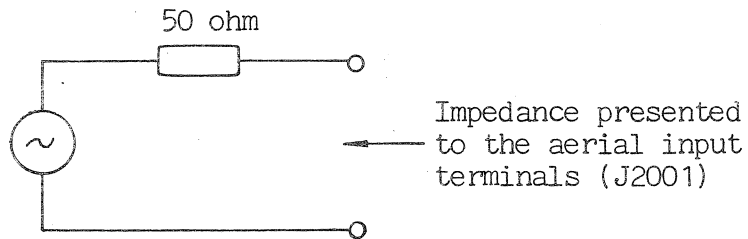

E.g. SAILOR Rx DUMMY LOAD type H219.

### 3. TROUBLE-SHOOTING

Trouble-shooting should only be performed by persons with sufficient technical knowledge, who have the necessary test equipment at their disposal, and who have carefully studied the operation principles and structure of the unit in question.

Start to find out whether the fault is somewhere in the antenna circuit, the power source, or in the short-wave set.

For help with trouble-shooting in the short-wave set there is a built-in test meter and test meter switch, located behind the air filter on the power supply.

When the fault has been located to a certain unit look up the PERFORMANCE CHECK list in the instruction book and make relevant performance check to incircle the fault. Then look up the CIRCUIT DESCRIPTION. This section contains schematic diagrams, description of the modules and pictures showing the location of the components. (ADJUSTMENT LOCATIONS).

Typical AC and DC voltages are indicated on the schematic diagrams.

No adjustment must take place unless the service workshop has the necessary test equipment to perform the ADJUSTMENT PROCEDURE in question.

After repair or replacement of the module look up the section NECESSARY ADJUSTMENTS AFTER REPAIR to see, whether the unit has to be adjusted or not.

Anyway the unit has to have a complete FUNCTION CHECK after repair.

## 4. PERFORMANCE CHECK FOR N1400

In order to make the performance check easier, the function of the power supply for the different modes, in which the power supply can operate, are listed in the tables below.

### 4.1.

TABLE I, POWER SUPPLY FUNCTION.

This table indicates the outputs from the power supply and in which conditions the different outputs are present. To achieve all these outputs, the power supply shall be connected to a short-wave set or controlled externally as indicated in 4.3. (table III) and 4.4. (table IV).

Used in	Use	Voltage (V)	Pin in J701	OFF	RECEIVER ONLY	STAND BY	ON		
			Common					keyed	
Receiver		22	Chassis 10, 16 22, 23	11	X	X	X	X	
		-45		12	X	X	X	X	
Exciter		22		25				X	X
		-45		24	X	X	X	X	X
Transmitter	Va	1.4/2K							XD
	Vg2	400		1					XD
	Vg2	400		4					XD
	Vg1	-60		18			X	X	X
	Vdriver	28	7					XD	
	Blower	220 AC	Between	33 36			X	X	X
	Filament	26.5	26, 27	6			X	X	X
		26.5		9		X	X	X	X
	26.5	15				X	X	X	
Receiver		8	chassis	13	X	X	X	X	

X voltage present

XD voltage present after delay

PERFORMANCE CHECK FOR N1400 cont.:

4.1.1.

The accuracy of voltages.

Following voltages are stabilized:

22V, Vg2, Vg1, Vdriver and 8V

22V and Vg2 = 400V within  $\pm 2\%$

Vg1 = -60V, Vdriver = 28V and 8V within  $\pm 5\%$

Other voltages are not stabilized and will vary with input voltage and load.

4.2.

TABLE II, VOLTAGE CHECK WITH SUPPLY VOLTAGE METER.

This table indicates in which way the meter marked SUPPLY VOLTAGE can be used for checking different voltages inside the power supply. Correct reading is when the pointer is in the middle of the green area.

NOTE: Va only reaches the green area when Va = 2kV (frequency above 4 MHz, or 405 - 535 kHz, pin 17 in J701 grounded).

This meter is only for checking, not for measuring voltages.

meter switch \ MAIN SWITCH	OFF	RECEIVER ONLY	STAND BY	ON	
					keyed
input		X	X	X	X
Va					XD
Vg2					XD
22V		X	X	X	X
Vdriver					XD
Vg1			X	X	X

After use leave the meter switch in pos. input.

SAILOR N1400

PERFORMANCE CHECK FOR N1400 cont.:

4.3.

TABLE III, CONTROL OF POWER SUPPLY.

This table indicates the state for the power supply, versus the control conditions. The MAIN SWITCH in position ON.

Control Conditions			State for P.S.	
Block P.S.	Transmitter start	Delay time past	Keyed	High Voltage present
pin 14 J701	pin 31 J701	30 secs for N1400E 6 secs		
grounded	22V	No		
grounded	0V	Yes		
grounded	22V	Yes	X	X
open	22V	Yes		
open	0V	Yes		

4.4.

TABLE IV, CONTROL OF Va VERSUS FREQUENCY.

This table indicates how the high voltage Va is changed when the frequency is changed.

Frequency	400/800W Control	High Voltage Va
MHz	pin 17 J701	kV
below 4	open	1.4
above 4	grounded	2
0.405 - 0.535	grounded	2

## 5. ADJUSTMENT PROCEDURE FOR N1400

5.1.  
ADJUSTMENT OF 22V.

5.1.1.  
With the voltmeter in 30V range connect the + terminal to TP1 and the - terminal to chassis. The MAIN SWITCH in pos. ON (if the power supply is separate, load the 22V with 3 - 3.5A).

5.1.2.  
Adjust with potentiometer R111 to the voltmeter reads 22.0V.

5.1.3.  
Connect an oscilloscope to TP1 and check that the ripple is less than 200 mVpp.

5.1.4.  
If possible vary the supply voltage and check that the 22V remains stable.

5.2.  
ADJUSTMENT OF  $V_{g2}$ .

5.2.1.  
With the voltmeter in 500 or 1000V range, connect the + terminal to TP2 and the - terminal to chassis. Key the short-wave set, but no drive to the PA stage (ex. A3J, no modulation). If the power supply is separate, key the power supply using the information in TABLE III 4.3.

5.2.2.  
Adjust with potentiometer R226 to the voltmeter reads 400V.

5.2.3.  
Move the voltmeter to TP3, the reading shall remain 400V, even though TP4 is short-circuited to chassis. With the voltmeter on TP4 check that the voltage remain 400V when TP3 is short-circuited to chassis.

5.2.4.  
Check that the voltage of TP5 is -60V.

5.2.5.  
Check that the voltage of TP6 is 28V.

## 6. NECESSARY ADJUSTMENTS AFTER REPAIR

6.1.  
AFTER REPAIR IN POWER UNIT I, PERFORM ADJUSTMENT IN ACCORDANCE WITH SECTION 5.1. ADJUSTMENT OF 22V.

6.2.  
AFTER REPAIR IN POWER UNIT II PERFORM ADJUSTMENT IN ACCORDANCE WITH SECTION 5.2. ADJUSTMENT OF  $V_{g2}$ .



## 7. FUNCTION CHECK FOR N1400

### 7.1.

FUNCTION CHECK WHEN THE POWER SUPPLY IS INSTALLED IN A SHORT-WAVE SET.

#### 7.1.1.

Using TABLE II section 4.2. check that the reading on the meter marked SUPPLY VOLTAGE is correct.

### 7.2.

FUNCTION CHECK WHEN THE POWER SUPPLY IS SEPARATE.

#### 7.2.1.

The power supply supplied with the correct input and controlled in accordance with TABLE III section 4.3. and TABLE IV section 4.4. Use TABLE II section 4.2. to check the function via the SUPPLY VOLTAGE meter.

#### 7.2.2.

When the power supply is separate and unloaded the power consumption can give information about the condition of the circuit.

Input Voltage	OFF	RECEIVER ONLY	STAND BY	ON		
					Keyed 1.4KV	Keyed 2KV
	Iin	Iin	Iin	Iin	Iin	Iin
24V DC	0	0.75	3	3	7.5	9.3

### 7.3.

NOTES FOR SUPPLY VOLTAGE METER.

#### 7.3.1.

In position Vg2 only Vg2 on pin 4 in J701 is checked.

#### 7.3.2.

In N1400 it is not possible to check the voltages -45V and 8V with the meter.

#### 7.3.3.

Working frequency of converters. The frequency is between 300 - 500 Hz.

BOTTOM VIEW

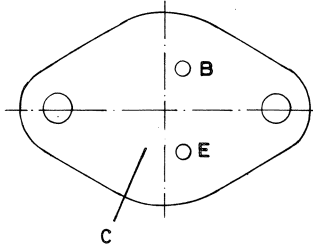

MJ 802  
MJ 3000  
2N5686

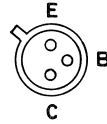

BC 141-10



BRY 39



2N5064

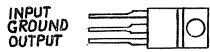

MC7808

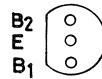

2N4871

# CIRCUIT DESCRIPTION N1400

## HIGH VOLTAGE UNIT

The HIGH VOLTAGE UNIT is made by three DC - DC converter units, which are identical except for the first one, which is self-oscillating. The two next ones are driven from the preceding converter.

The high voltage can be either 1.4 kV or 2 kV dependent on whether the third converter is driven or not. The drive is controlled via relay RE301 (400/800 W Control).

The high voltage unit starts when +22V is supplied to the relays RE302 and RE303. RE302 has no time delay and supplies DC bias to the transistors T301 and T302 and opens up for the feed-back of AC via transformer TR301 and oscillation starts. After the delay time for RE303 (50 - 90 mS ), the DC bias to T301 and T302 is disconnected and only AC is fed back. If an overload comes up, the collector-collector impedance is reduced, the feed-back disappears and the converter stops.

NOTE! In order to ensure the correct function of the converters during overload: the transistors T301 and T302 must have lower  $h_{FE}$  or the same as T303 - T306 (matched pairs).

When the high voltage is 1.4 kV the diodes D318 and D319 protect the rectifier circuits with D316 and D317 if an overload or a flash-over take place. C320, R324, D320 and D321 suppress high voltages during start and switching.

## POWER UNIT I

This unit supplies the receiver and the exciter with the voltages +8V, +22V, -45V. and insulates the battery from the chassis.

The transistors T101 and T102 together with the matching transformers TR101 and TR102 are a DC-DC converter which gives two output voltages, the negative one is -45V and unstabilized. The other output is positive and via the regulator, consisting of the transistors T103 and T104 and the 7.5V zener diode D105 stabilized to +22V, adjustment of +22V is made by R111. The output +22V is secured against overload by the fuse F702 6.3A.

The diode D106 limits the peak current through the switch S701, because the capacitor C103 is charged-up.

## POWER UNIT II

This unit supplies the transmitter and the driver unit with stabilized voltages. The input to the DC-DC converter is stabilized in the regulator, consisting of the transistors T201 and T202 and the 7.5V zener diode D201.

The output from the regulator is fed to the DC-DC converter with the transistors T203 and T204 and the matching transformers TR201 and TR202. The four outputs of the transformer TR202 are thereby stabilized and adjustment of the voltages is made by R226. The ratio of the voltages is determined by the transformer TR202.

The output Vg1 -60V is present as soon as the unit is in function, whereas the outputs V<sub>driver</sub> +28V and the two Vg2 +400V are controlled by the +22V to the relays RE201, RE202 and RE203 (Transmitter start).

The circuit for the Vg2 supply is made so that the currents to the screens in the PA tubes are limited due to R219 and R220. If a screen tends to emit the increase of screen voltage is prevented due to a low impedance in the circuit consisting of R218 and the diodes D208 and D209.

The POWER UNIT II has built-in resistors for the TEST METER.

#### DELAY UNIT

The DELAY UNIT starts when it is connected. Across the zener diode D401 there is a voltage of 7.5V and the capacitor C404 starts charging up via resistor R407, when the anode gate is 0.7V below the anode, the D401 is triggered and the capacitor C404 is discharged.

In order to ensure enough current in the gate, a negative going pulse 200 - 500 mS of 0.7V is fed to the gate via C403.

The discharge of C404 causes a positive pulse across R406. The SCR D405 is triggered and relay RE402 is closed.

Relay RE401 is controlled via the control input Block P.S., when both relays are closed control inputs are allowed to pass through the DELAY UNIT.

#### 50 Hz CONVERTER

This unit supplies the blowers with AC voltages with a frequency of 50 - 60 Hz dependent on the input voltage. The converter consists of the transistors T501 and T502 and the matching transformers TR501 and TR502. The diodes D503 and D504 limit the voltage with reversal polarity across T501 and T502.

The diode D505 limits the peak current through the switch S701, because the capacitor C501 is charged up. R504, C502 and C503 suppress high voltages during switching T501 and T502.

#### TEST METER

When using the SUPPLY VOLTAGE meter M601 and the switch S601, voltages are monitored. The resistors are placed either on the test meter print or in the different units.

#### MAIN SWITCH

The switch S701 controls the function of the power supply and it is operated from the front.

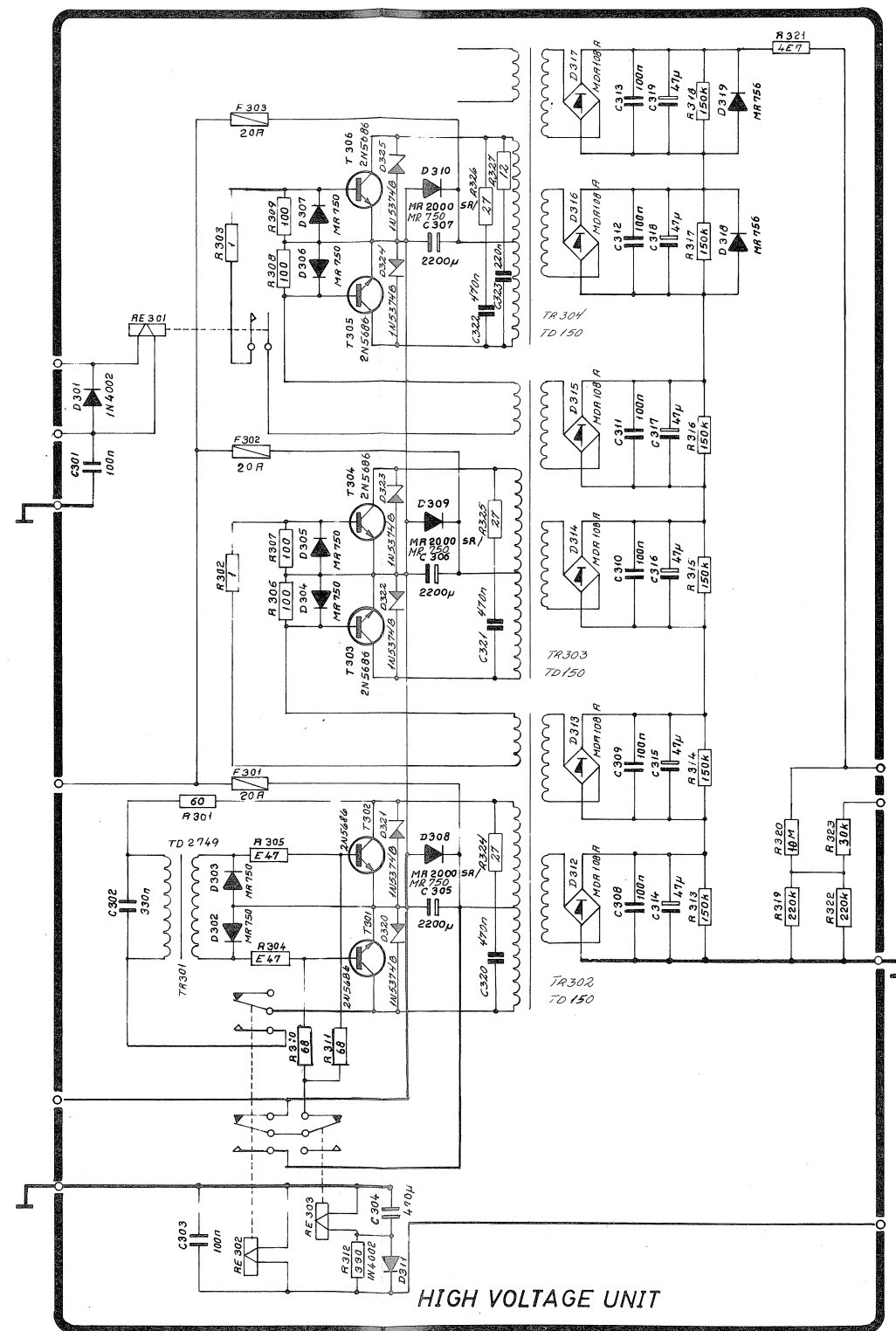
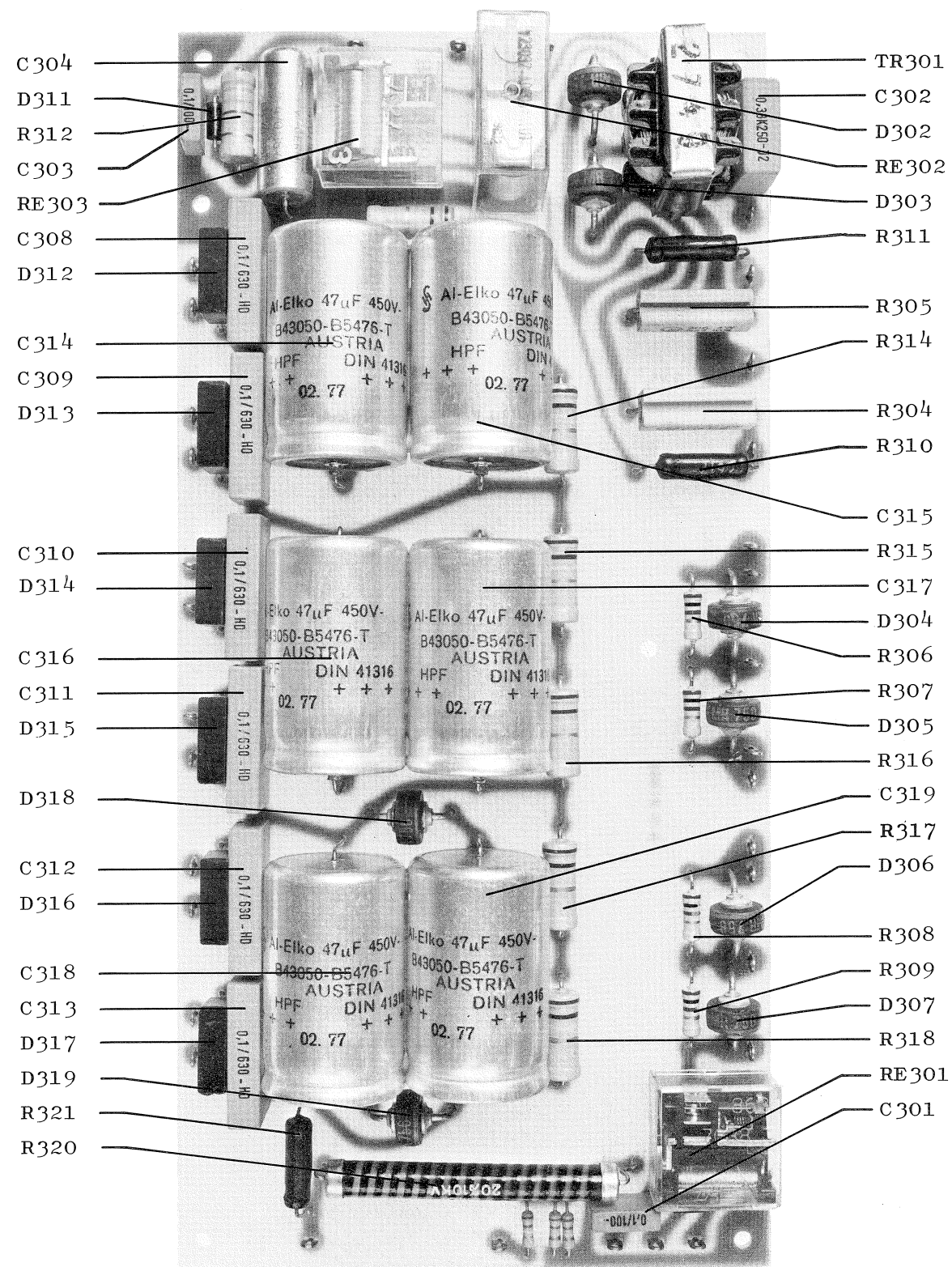

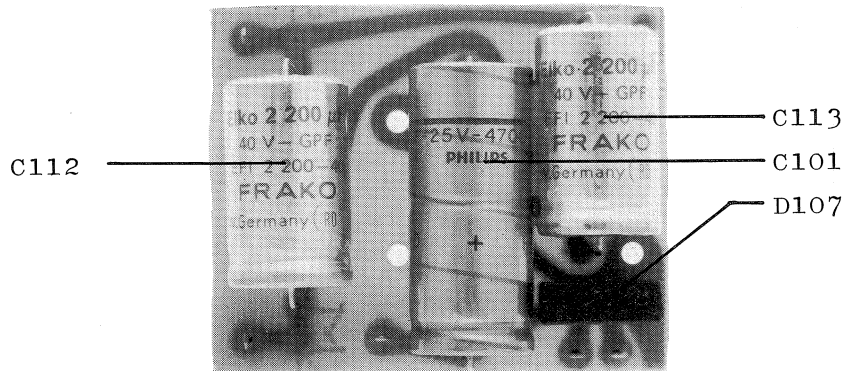
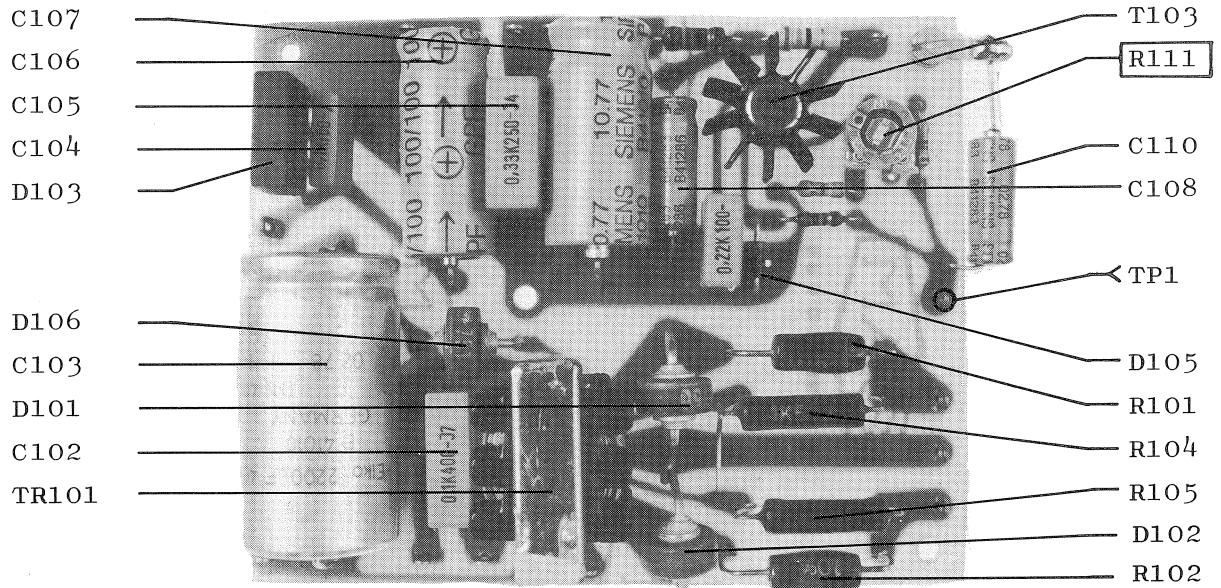
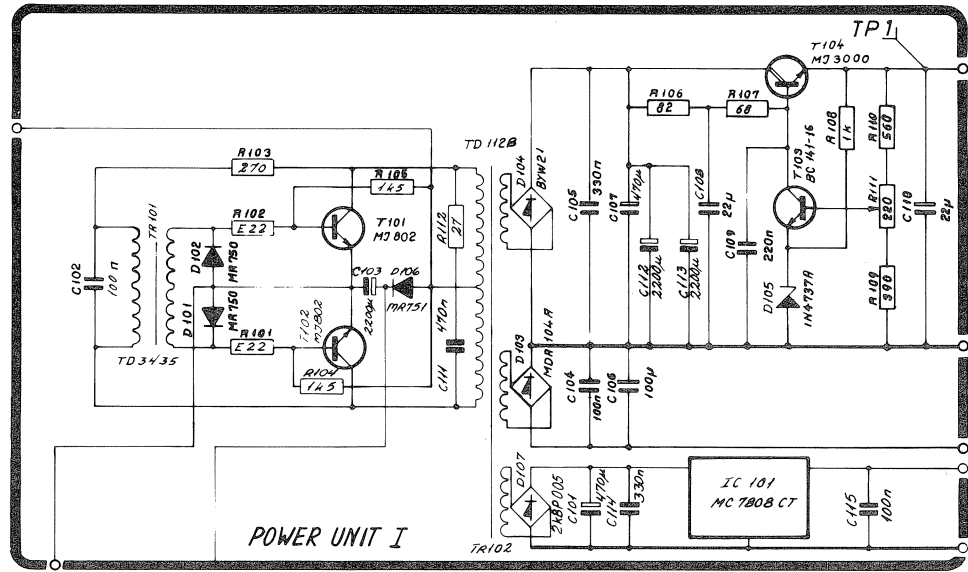



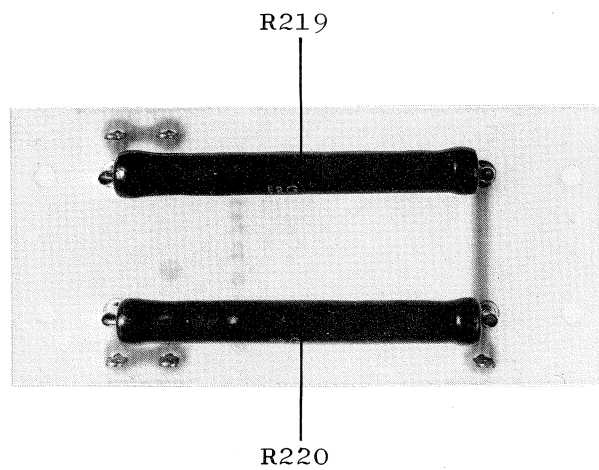
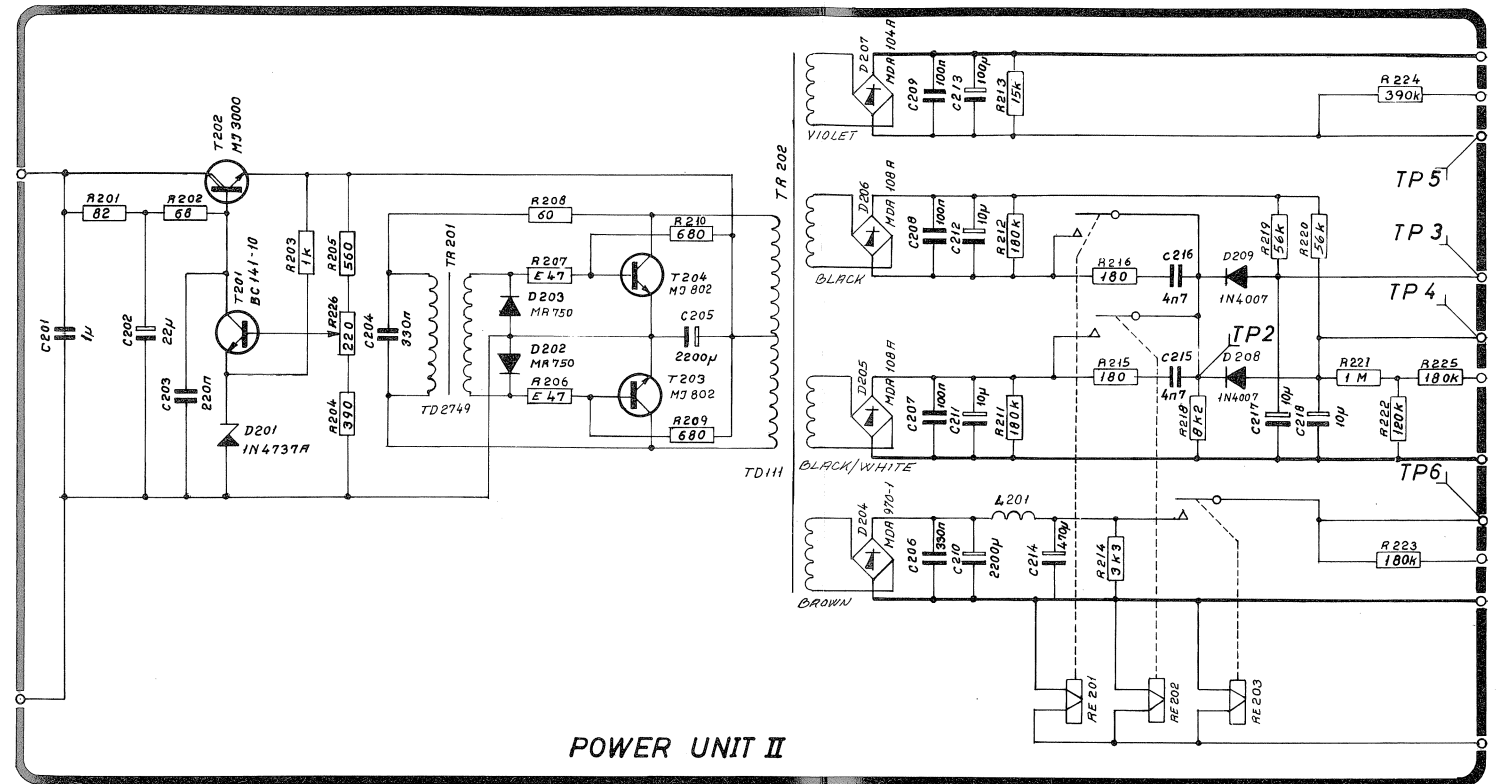
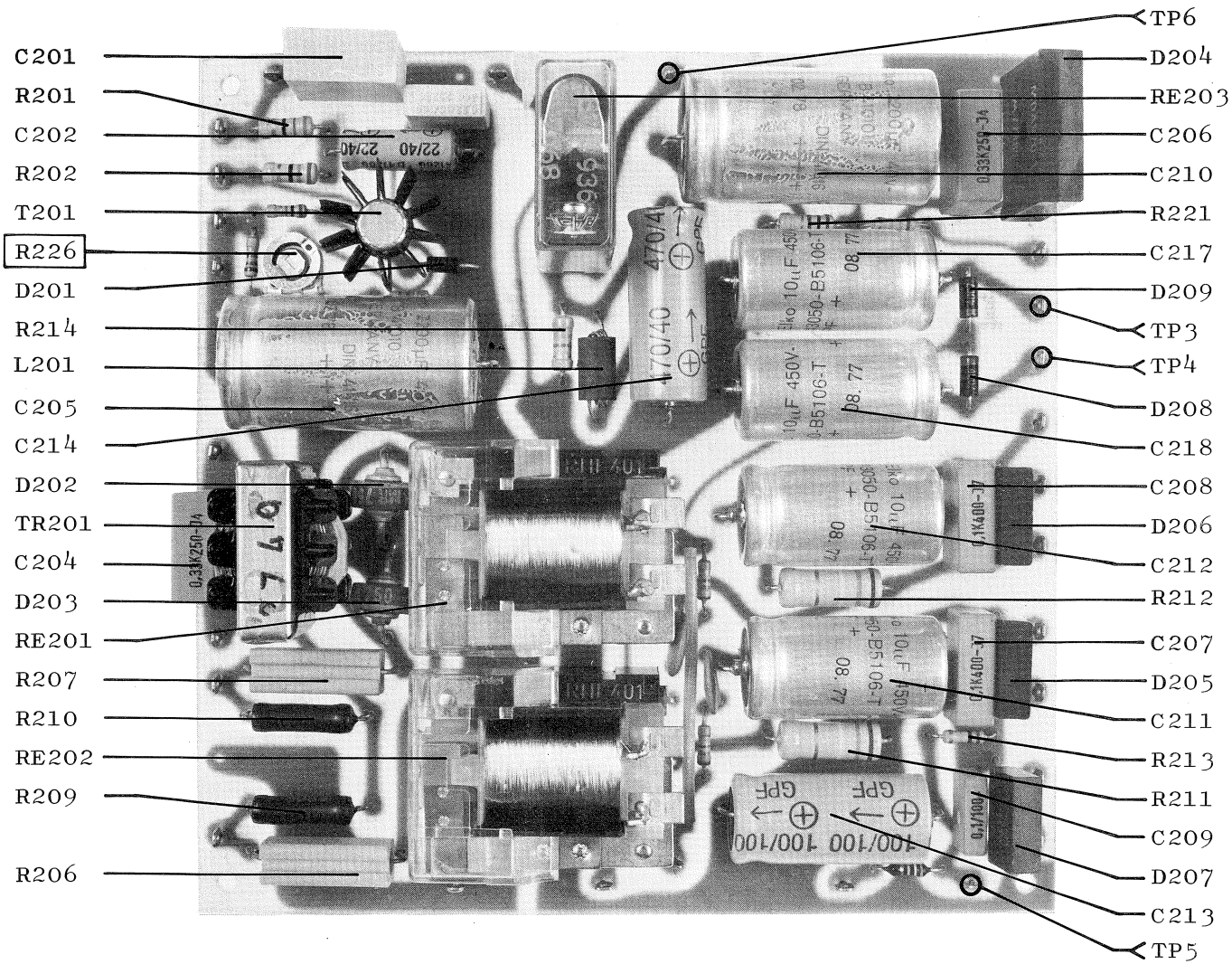

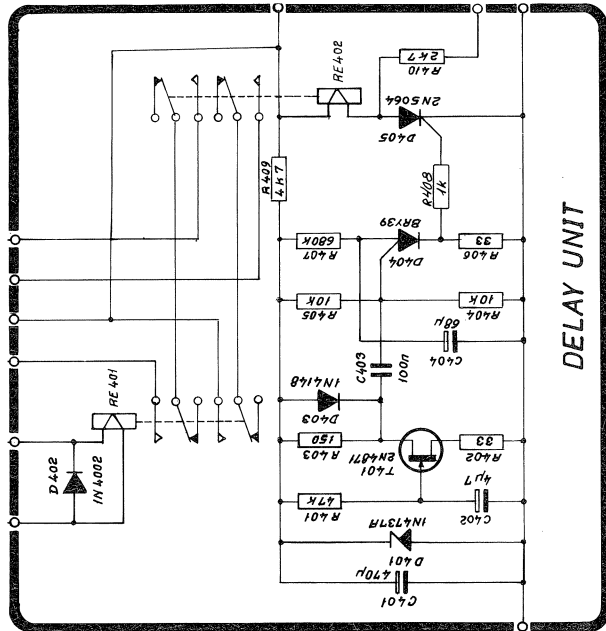

DELAY UNIT

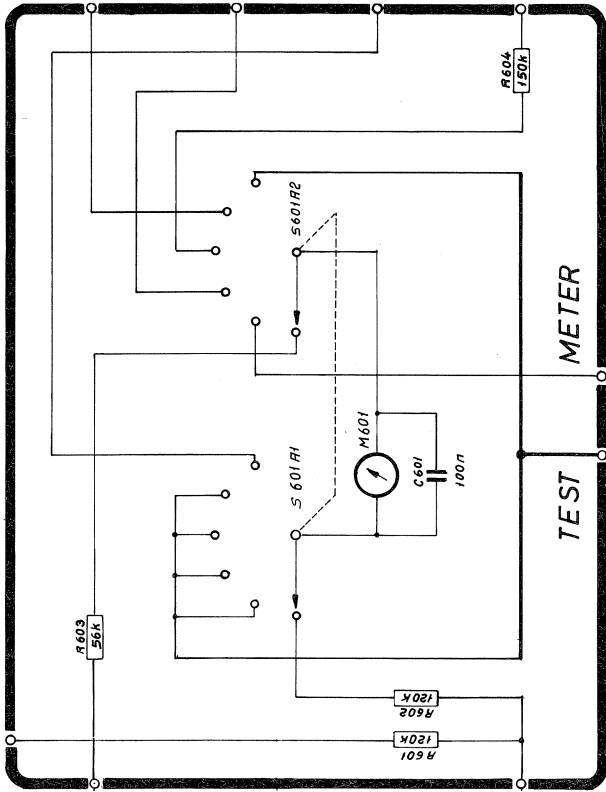
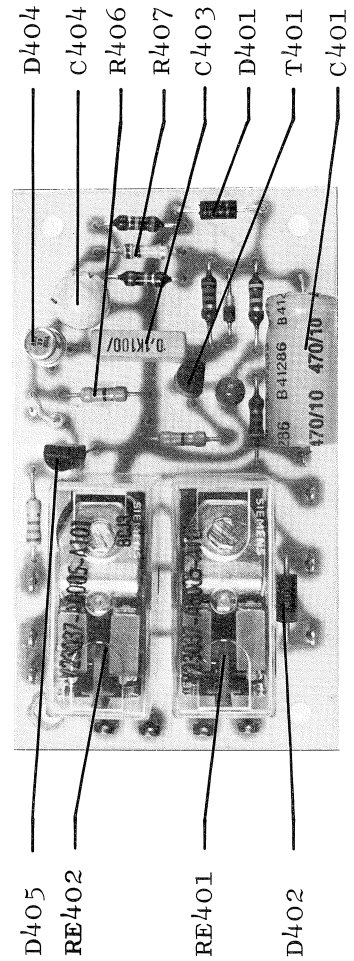

METER

TEST

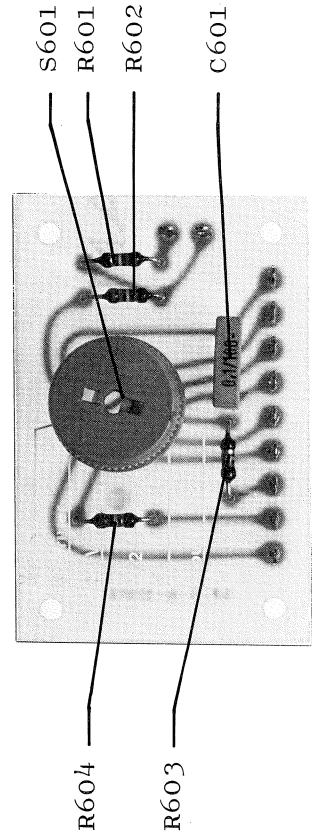

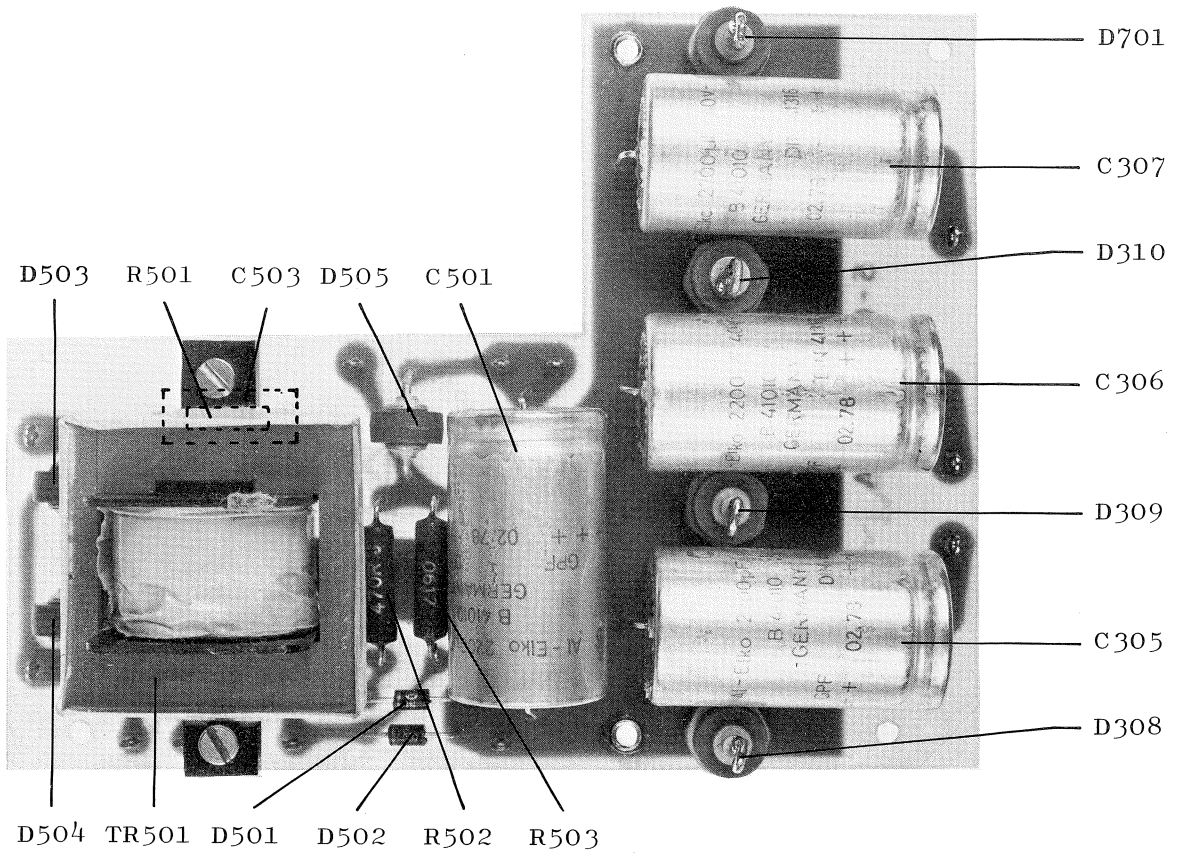
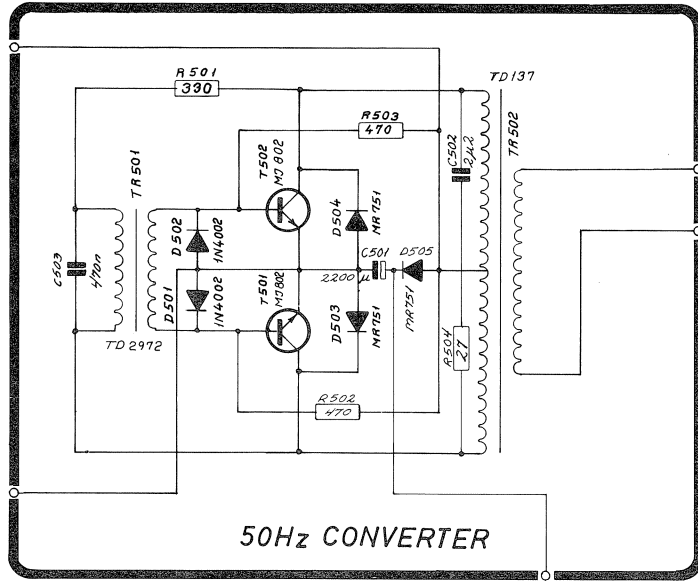



N1400 FRONT VIEW

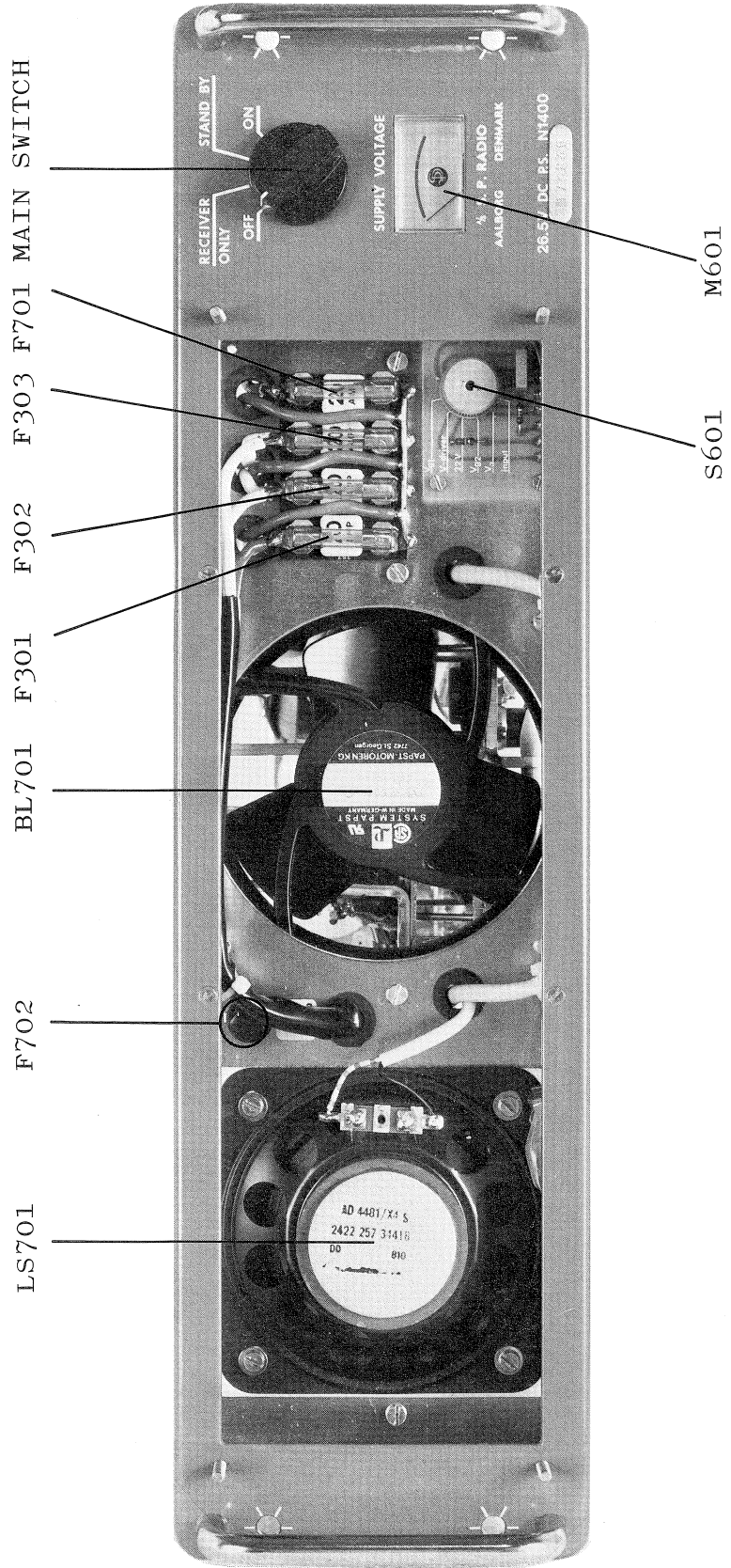

N1400 TOP VIEW

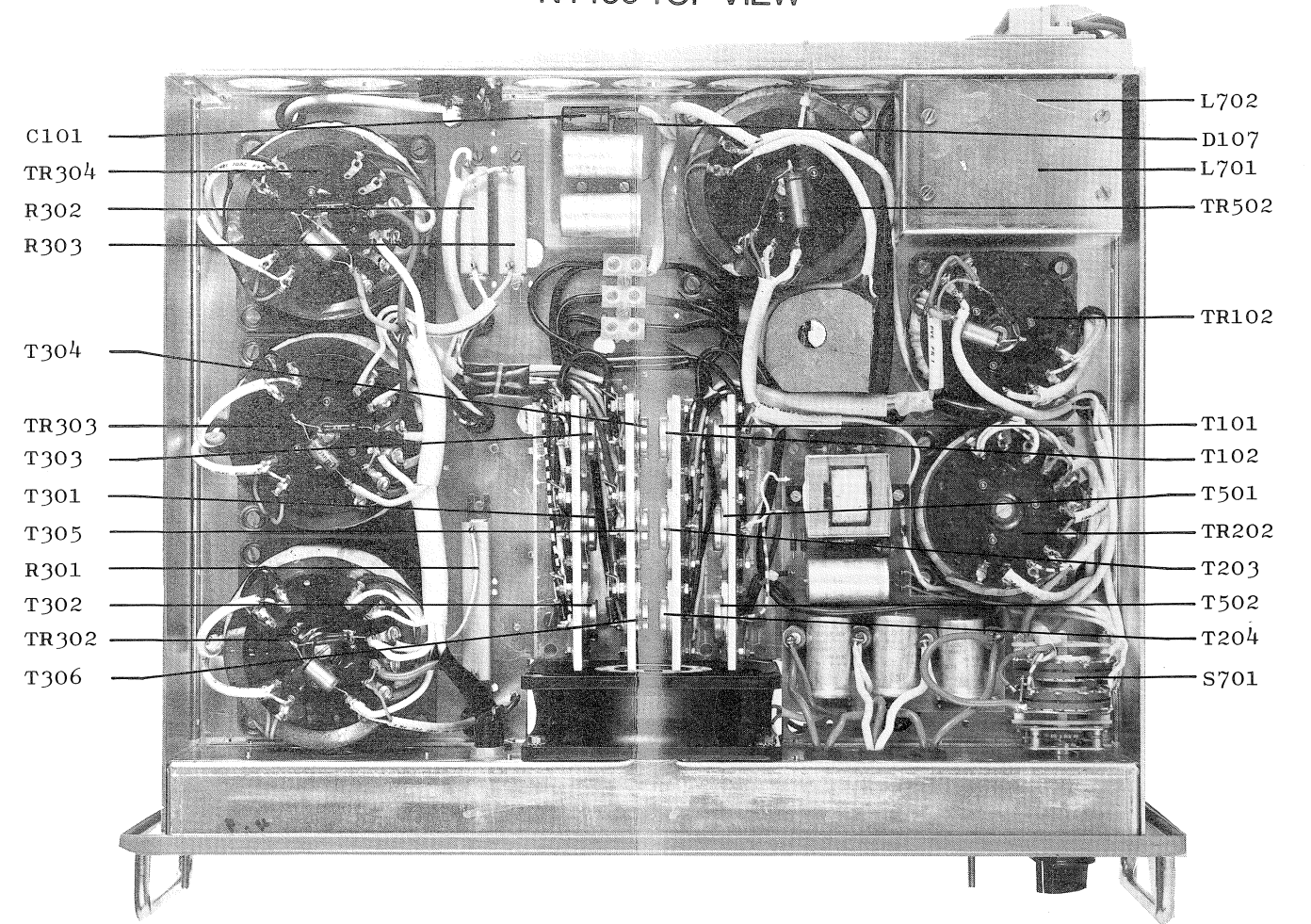

N1400 BOTTOM VIEW

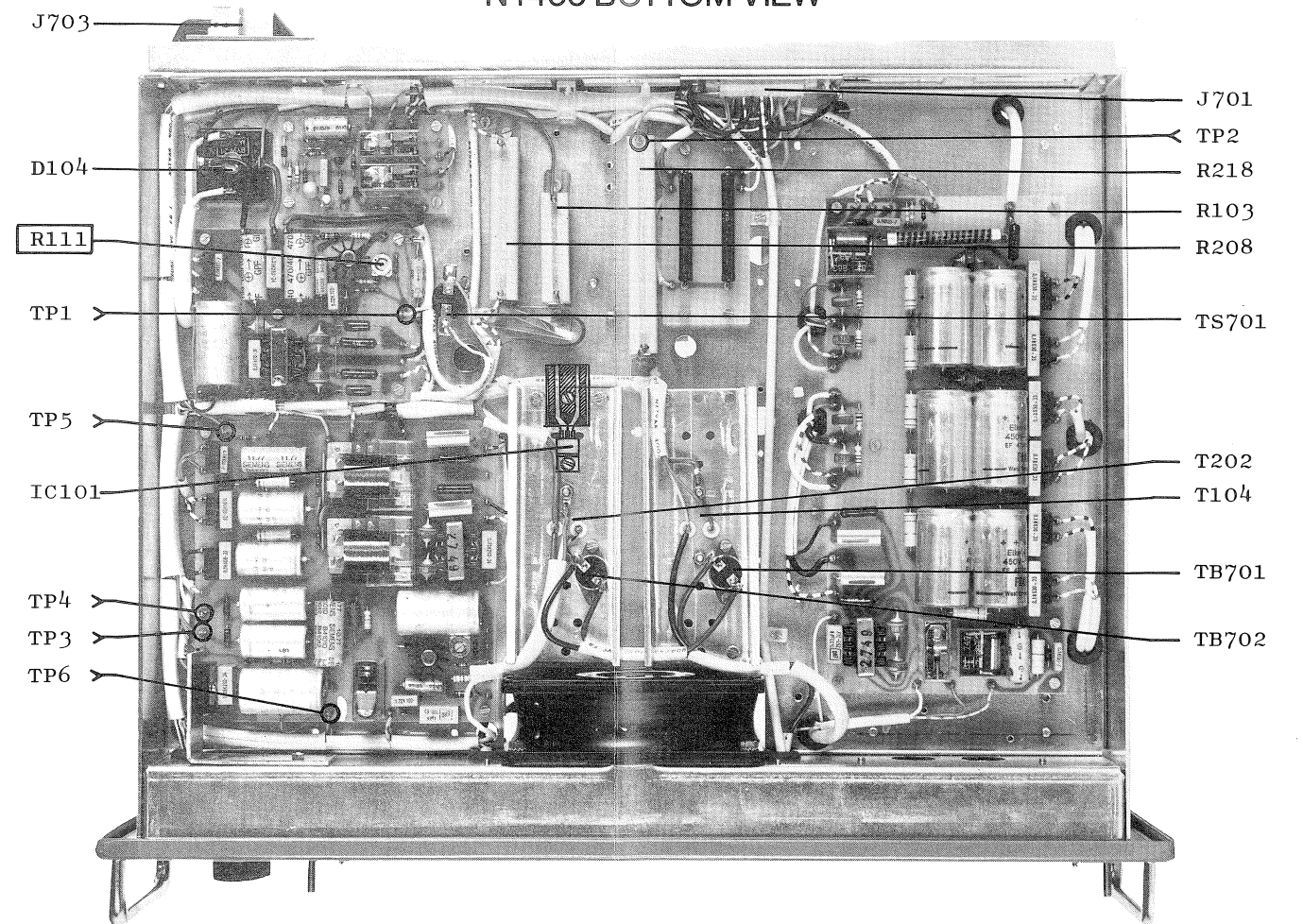

d

## Power unit I N1400

<i>Symbol</i>	<i>Description</i>			<i>Manufact.</i>	
R101	Resistor	0,22 ohm	4W	Philips	2322 329 34227
R102	Resistor	0,22 ohm	4W	Philips	2322 329 34227
R103	Resistor	270 ohm 5%	15W	Vitrohm	220-0
R104	Resistor	1,5 Kohm	4,2W	Philips	2322 330 22152
R105	Resistor	1,5 Kohm	4,2W	Philips	2322 330 22152
R106	Resistor	82 ohm	0,5W	Philips	2322 212 13829
R107	Resistor	68 ohm	0,5W	Philips	2322 212 13689
R108	Resistor	1Kohm	0,33W	Philips	2322 211 13102
R109	Resistor	390 ohm	0,33W	Philips	2322 211 13391
R110	Resistor	560 ohm	0,33W	Philips	2322 211 13561
R111	Potentiometer	220 ohm 20%		Noble	TM8KV2-1S-220
R112	Resistor	27 ohm	4,2W	Philips	2322 330 22279
C101	Capacitor electrolytic	4700uF	25V	Philips	2222 021 16472
C102	Capacitor polyester	0,1uF	400V	ERO	MKT 1822-410/4
C103	Capacitor electrolytic	2200uF	40V	Siemens	B41010-C7228-T
C104	Capacitor polyester	0,1uF	100V	ERO	MKT 1822-410/0
C105	Capacitor polyester	0,33uF	250V	ERO	MKT 1822-433/2
C106	Capacitor electrolytic	100uF	100V	Siemens	B41010-A9107-T
C107	Capacitor electrolytic	470uF	40V	Siemens	B41010-A7477-T
C108	Capacitor electrolytic	22uF	40V	Siemens	B41283-B7226-T
C109	Capacitor polyester	0,22uF	100V	ERO	MKT 1822-422/0
C110	Capacitor electrolytic	22uF	40V	Siemens	B41283-B7226-T
C111	Capacitor polyester	0,47uF	250V	ERO	MKC 1860-447/2
C112	Capacitor electrolytic	2200uF	40V	FRAKO	EFI 2200-4
C113	Capacitor electrolytic	2200uF	40V	FRAKO	EFI 2200-4
C114	Capacitor	0,33uF	100V	ERO	MKT 1822-433/0
C115	Capacitor	0,1uF	100V	ERO	MKT 1822-410/0
T101	Transistor	matched pair		Motorola	MJ802
T102	Transistor			Motorola	MJ802
T103	Transistor			Siemens	BC141-16
T104	Transistor			Motorola	MJ3000
D101	Diode			Motorola	MR750
D102	Diode			Motorola	MR750
D103	Diode bridge			Motorola	MDA104A/MDA204
D104	Diode bridge			Motorola	BYW21
D105	Diode Zener	7,5V		Motorola	1N4737A
D106	Diode			Motorola	MR751
D107	Diode bridge			G.I.	2KBP 005
IC101	Integrated circuit			Motorola	MC 7808 CT
TR101	Transformer			Tradania	TD3435
TR102	Transformer			Tradania	TD112B

c

## Power unit II N1400/N1401

Symbol	Description	Manufact.	
R201	Resistor 82 ohm 0,5W	Philips	2322 212 13829
R202	Resistor 68 ohm 0,5W	Philips	2322 212 13689
R203	Resistor 1Kohm 0,33W	Philips	2322 211 13102
R204	Resistor 390 ohm 0,33W	Philips	2322 211 13391
R205	Resistor 560 ohm 0,33W	Philips	2322 211 13561
R206	Resistor 0,47 ohm 10% 4W	Vitrohm	206-0
R207	Resistor 0,47 ohm 10% 4W	Vitrohm	206-0
R208	Resistor 60 ohm 5% 23W	Vitrohm	222-0
R209	Resistor 680 ohm 4,2W	Philips	2322 330 22681
R210	Resistor 680 ohm 4,2W	Philips	2322 330 22681
R211	Resistor 180Kohm 1,15W	Philips	2322 214 13184
R212	Resistor 180Kohm 1,15W	Philips	2322 214 13184
R213	Resistor 15Kohm 0,33W	Philips	2322 211 13153
R214	Resistor 3,3Kohm 0,5W	Philips	2322 211 13332
R215	Resistor 180 ohm 0,33W	Philips	2322 211 13181
R216	Resistor 180 ohm 0,33W	Philips	2322 211 13181
R218	Resistor 8,2Kohm 5% 30W	Vitrohm	224-0
R219	Resistor 56Kohm 5% 12W	Danotherm	GAN 12
R220	Resistor 56Kohm 5% 12W	Danotherm	GAN 12
R221	Resistor 1Mohm 0,5W	Philips	2322 212 13105
R222	Resistor 120Kohm 0,33W	Philips	2322 211 13124
R223	Resistor 180Kohm 0,33W	Philips	2322 211 13184
R224	Resistor 390Kohm 0,33W	Philips	2322 211 13394
R225	Resistor 180Kohm 0,33W	Philips	2322 211 13184
R226	Potentiometer 220 ohm	Draloric	70 WTD-K-C
C201	Capacitor polyester 1uF 100V	ERO	MKT1822-510/0
C202	Capacitor electrolytic 22uF 40V	Siemens	B41283-B7226-T
C203	Capacitor polyester 0,22uF 100V	ERO	MKT1822-422/0
C204	Capacitor polyester 0,33uF 250V	ERO	MKT1822-433/2
C205	Capacitor electrolytic 2200uF 40V	Siemens	B41010-C7228-T
C206	Capacitor polyester 0,33uF 250V	ERO	MKT1822-433/2
C207	Capacitor polyester 0,1uF 400V	ERO	MKT1822-410/4
C208	Capacitor polyester 0,1uF 400V	ERO	MKT1822-410/4



C

## Power unit II N1400/N1401

Symbol	Description	Manufact.	
C209	Capacitor polyester 0,1uF 100V	ERO	MKT1822-410/0
C210	Capacitor electrolytic 2200uF 40V	Siemens	B41010-C7228-T
C211	Capacitor electrolytic 10uF 450V	Siemens	B43050-B5106-T
C212	Capacitor electrolytic 10uF 450V	Siemens	B43050-B5106-T
C213	Capacitor electrolytic 100uF 100V	Siemens	B41010-A9107-T
C214	Capacitor electrolytic 470uF 40V	Siemens	B41010-A7477-T
C215	Capacitor ceramic 4,7nF 400V	Ferroperm	9/0138,9
C216	Capacitor ceramic 4,7nF 400V	Ferroperm	9/0138,9
C217	Capacitor electrolytic 10uF 450V	Siemens	B43050-B5106-T
C218	Capacitor electrolytic 10uF 450V	Siemens	B43050-B5106-T
T201	Transistor	Siemens	BC141-10
T202	Transistor	Motorola	MJ3000
T203	Transistor	Motorola	BUV49
T204	Transistor matched pair	Motorola	BUV49
D201	Diode zener 7,5V	Motorola	1N4737A
D202	Diode	Motorola	MR750
D203	Diode	Motorola	MR750
D204	Diode bridge	Motorola	MDA970-1
D205	Diode bridge	Motorola	MDA108A/MDA208
D206	Diode bridge	Motorola	MDA108A/MDA208
D207	Diode bridge	Motorola	MDA104A/MDA204
D208	Diode	Motorola	1N4007
D209	Diode	Motorola	1N4007
L201	Coil	S.P.	Drg.No. TL067
TR201	Transformer	Tradania	TD2749
TR202	Transformer	Tradania	TD111
RE201	Relay	AEG	RHL401 24V/02
RE202	Relay	AEG	RHL401 24V/02
RE203	Relay	PASI	KH/A BV 936

A

## High Voltage unit N1400

Symbol	Description	Manufact.	
R301	Resistor 60 ohm 5% 2,5W	Vitrohm	222-0
R302	Resistor 1 ohm 10% 1,5W	Vitrohm	220-0
R303	Resistor 1 ohm 10% 1,5W	Vitrohm	220-0
R304	Resistor 0,47 ohm 10% 4W	Vitrohm	206-0
R305	Resistor 0,47 ohm 10% 4W	Vitrohm	206-0
R306	Resistor 100 ohm 0,5W	Philips	2322 212 13101
R307	Resistor 100 ohm 0,5W	Philips	2322 212 13101
R308	Resistor 100 ohm 0,5W	Philips	2322 212 13101
R309	Resistor 100 ohm 0,5W	Philips	2322 212 13101
R310	Resistor 68 ohm 4,2W	Philips	2322 330 22689
R311	Resistor 68 ohm 4,2W	Philips	2322 330 22689
R312	Resistor 330 ohm 1,15W	Philips	2322 214 13331
R313	Resistor 150 Kohm 1,15W	Philips	2322 214 13154
R314	Resistor 150 Kohm 1,15W	Philips	2322 214 13154
R315	Resistor 150 Kohm 1,15W	Philips	2322 214 13154
R316	Resistor 150 Kohm 1,15W	Philips	2322 214 13154
R317	Resistor 150 Kohm 1,15W	Philips	2322 214 13154
R318	Resistor 150 Kohm 1,15W	Philips	2322 214 13154
R319	Resistor 220 Kohm 0,33W	Philips	2322 211 13224
R320	Resistor 10 Mohm 10% 1W	Philips	2322 244 13106
R321	Resistor 4,7 ohm 4,2W	Philips	2322 330 22478
R322	Resistor 220 Kohm 0,33W	Philips	2322 211 13224
R323	Resistor 30 Kohm 5% 0,4W	Philips	2322 181 53303
R324	Resistor 27 ohm 4,2W	Philips	2322 330 22279
R325	Resistor 27 ohm 4,2W	Philips	2322 330 22279
R326	Resistor 27 ohm 4,2W	Philips	2322 330 22279
R327	Resistor 12 ohm 4,2W	Philips	2322 330 21129
C301	Capacitor polyester 0,1 uF 100V	ERO	MKT 1822-410/0
C302	Capacitor polyester 0,33 uF 250V	ERO	MKT 1222-433/2
C303	Capacitor polyester 0,1 uF 100V	ERO	MKT 1222-410/0
C304	Capacitor electrolytic 470 uF 16V	Siemens	B41283-A4477-T
C305	Capacitor electrolytic 2200 uF 40V	Siemens	B41010-C7228-T
C306	Capacitor electrolytic 2200 uF 40V	Siemens	B41010-C7228-T
C307	Capacitor electrolytic 2200 uF 40V	Siemens	B41010-C7228-T
C308	Capacitor polyester 0,1 uF 630V	ERO	MKT 1822-410/6
C309	Capacitor polyester 0,1 uF 630V	ERO	MKT 1822-410/6
C310	Capacitor polyester 0,1 uF 630V	ERO	MKT 1822-410/6
C311	Capacitor polyester 0,1 uF 630V	ERO	MKT 1822-410/6

a

## High Voltage unit N1400

Symbol	Description	Manufact.	
C312	Capacitor polyester 0,1 uF 630V	ERO	MKT 1822-410/6
C313	Capacitor polyester 0,1 uF 630V	ERO	MKT 1822-410/6
C314	Capacitor electrolytic 47 uF 450V	Siemens	B43050-B5476-T
C315	Capacitor electrolytic 47 uF 450V	Siemens	B43050-B5476-T
C316	Capacitor electrolytic 47 uF 450V	Siemens	B43050-B5476-T
C317	Capacitor electrolytic 47 uF 450V	Siemens	B43050-B5476-T
C318	Capacitor electrolytic 47 uF 450V	Siemens	B43050-B5476-T
C319	Capacitor electrolytic 47 uF 450V	Siemens	B43050-B5476-T
C320	Capacitor polyester 0,47 uF 250V	ERO	MKC 1860-447/2
C321	Capacitor polyester 0,47 uF 250V	ERO	MKC 1860-447/2
C322	Capacitor polyester 0,47 uF 250V	ERO	MKC 1860-447/2
C323	Capacitor polyester 0,22 uF 250V	ERO	MKC 1860-422/2
T301	Transistor matched pair	Motorola	2N5686
T302	Transistor	Motorola	2N5686
T303	Transistor matched pair	Motorola	2N5686
T304	Transistor	Motorola	2N5686
T305	Transistor matched pair	Motorola	2N5686
T306	Transistor	Motorola	2N5686
D301	Diode	Motorola	1N4002
D302	Diode	Motorola	MR750
D303	Diode	Motorola	MR750
D304	Diode	Motorola	MR750
D305	Diode	Motorola	MR750
D306	Diode	Motorola	MR750
D307	Diode	Motorola	MR750
D308	Diode	Motorola	MR2500SR
D309	Diode	Motorola	MR2500SR
D310	Diode	Motorola	MR2500SR
D311	Diode	Motorola	1N4002
D312	Diode bridge	Motorola	MDA108A/MDA208
D313	Diode bridge	Motorola	MDA108A/MDA208
D314	Diode bridge	Motorola	MDA108A/MDA208
D315	Diode bridge	Motorola	MDA108A/MDA208
D316	Diode bridge	Motorola	MDA108A/MDA208
D317	Diode bridge	Motorola	MDA108A/MDA208
D318	Diode	Motorola	MR756

High Voltage unit N1400

<i>Symbol</i>	<i>Description</i>	<i>Manufact.</i>	
D319	Diode	Motorola	MR756
D320	Diode Zener	75V Motorola	1N5374B
D321	Diode Zener	75V Motorola	1N5374B
D322	Diode Zener	75V Motorola	1N5374B
D323	Diode Zener	75V Motorola	1N5374B
D324	Diode Zener	75V Motorola	1N5374B
D325	Diode Zener	75V Motorola	1N5374B
TR301	Transformer	Tradania	TD2749
TR302	Transformer	Tradania	TD150
TR303	Transformer	Tradania	TD150
TR304	Transformer	Tradania	TD150
RE301	Relay	PASI	MS/K BV 863
RE302	Relay	Siemens	V23037-A0005-A101
RE303	Relay	PASI	MS/K BV 749
F301	Fuse	20A Wickmann	PL411020
F302	Fuse	20A Wickmann	PL411020
F303	Fuse	20A Wickmann	PL411020

**b**

## Delay unit N1400/N1401

Symbol	Description	Manufact.	
R401	Resistor 47Kohm	Philips	0,33W 2322 211 13473
R402	Resistor 33 ohm	Philips	0,33W 2322 211 13339
R403	Resistor 150 ohm	Philips	0,33W 2322 211 13151
R404	Resistor 10Kohm	Philips	0,33W 2322 211 13103
R405	Resistor 10Kohm	Philips	0,33W 2322 211 13103
R406	Resistor 33 ohm	Philips	0,33W 2322 211 13339
R407	Resistor 680Kohm	Philips	0,33W 2322 211 13684
R408	Resistor 1Kohm	Philips	0,33W 2322 106 13102
R409	Resistor 4,7Kohm	Philips	0,33W 2322 211 13472
R410	Resistor 2,7Kohm	Philips	0,33W 2322 211 13272
C401	Capacitor electrolytic 470uF	Siemens	10V B41283-A3477-T
C402	Capacitor tantal 4,7uF	ERO	35V ETP2E 4.7/35
C403	Capacitor polyester 0,1uF	ERO	100V MKT 1822-410/0
C404	Capacitor tantal 68uF $\pm 10\%$	ERO	16V ETQ5 68/16 $\pm 10\%$
T401	Transistor UJT	Motorola	2N4871
D401	Diode zener	Motorola	7,5V 1N4737A
D402	Diode	Motorola	1N4002
D403	Diode	Texas	1N4148
D404	Diode SCR	Philips	BRY39
D405	Diode SCR	Motorola	2N5064
RE401	Relay	Siemens	V23037-A0005-A101
RE402	Relay	Siemens	V23037-A0005-A101
	<u>For N1400E only.</u>		
R407	Resistor 120Kohm	Philips	0,33W 2322 211 13124

**b**

## 50 Hz converter N1400

<i>Symbol</i>	<i>Description</i>		<i>Manufact.</i>		
R501	Resistor	330 ohm	4,2W	Philips	2322 330 22331
R502	Resistor	470 ohm	4,2W	Philips	2322 330 22471
R503	Resistor	470 ohm	4,2W	Philips	2322 330 22471
R504	Resistor	27 ohm	4,2W	Philips	2322 330 22279
C501	Capacitor electrolytic	2200uF	40V	Siemens	B41010-C7228-T
C502	Capacitor	2,2 uF	100V	ERO	MKC 1860-522/0
C503	Capacitor polyester	0,47uF	250V	ERO	MKC 1860-447/2
T501	Transistor	matched pair		Motorola	MJ802
T502	Transistor			Motorola	MJ802
D501	Diode			Motorola	1N4002
D502	Diode			Motorola	1N4002
D503	Diode			Motorola	MR751
D504	Diode			Motorola	MR751
D505	Diode			Motorola	MR751
TR501	Transformer			Tradania	TD2972
TR502	Transformer			Tradania	TD137

Testmeter N1400 /N1401

<i>Symbol</i>	<i>Description</i>			<i>Manufact.</i>	
R601	Resistor	120Kohm	0,33W	Philips	2322 211 13124
R602	Resistor	120Kohm	0,33W	Philips	2322 211 13124
R603	Resistor	56Kohm	0,33W	Philips	2322 211 13563
R604	Resistor	150Kohm	0,33W	Philips	2322 211 13154
C601	Capacitor polyester	0,1uF	100V	ERO	MKT1822-410/0
M601	Meter			Aug.Eklöw	MG20 Drg. No. 9-3-21496
S601	Switch			ITT	R8P 12F 2x6NCC

d

## Chassis N1400

Symbol	Description	Manufact.	
C701	Capacitor polyester 1 uF 100V	Philips	2222 341 29105
C702	Capacitor polyester 1 uF 100V	Philips	2222 341 29105
C703	Capacitor polyester 1 uF 100V	Philips	2222 341 29105
C704	Capacitor polyester 1 uF 100V	Philips	2222 341 29105
C705	Capacitor polyester 1 uF 100V	Philips	2222 341 29105
D701	Diode	Motorola	MR2000SR/MR750
L701	Coil	Tradania	TD3125
L702	Coil	Tradania	TD3125
F701	Fuse 20A	Wickmann	PL411020
F702	Fuse 6,3A	ELU	5x20 mm 6,3A
S701	Switch	NSF	HD 120231 S MSD 2
J701	Receptacle	Molex	1772-2
J702	Socket	Hirschmann	Meb 160
J703	Plug	Weidmüller	STV 2/10-3338.6
LS701	Loudspeaker	Philips	2422 257 34437
BL701	Blower 220V AC	PAPST	Typ 4550N
TB701	Thermal Breaker	Elmwood	2455R-21-910
TB702	Thermal Breaker	Elmwood	2455R-21-910
TS701	Thermostat	Elmwood	2455R-21-923
FP701	Ferroxcube beads	Kaschke	K3/1200/0.1Hz 4/2/7A



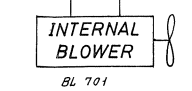
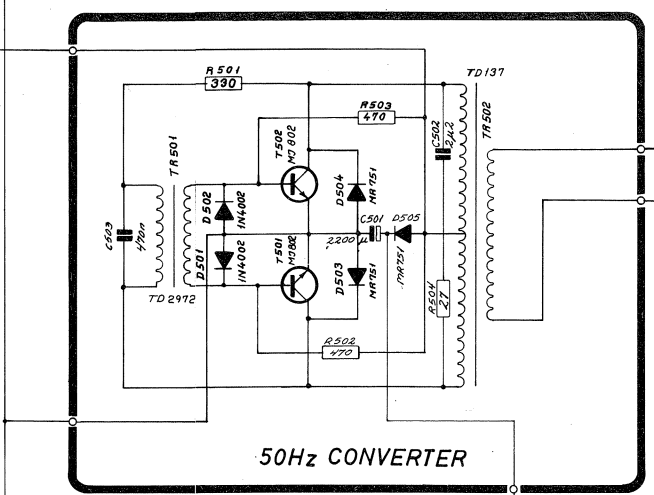
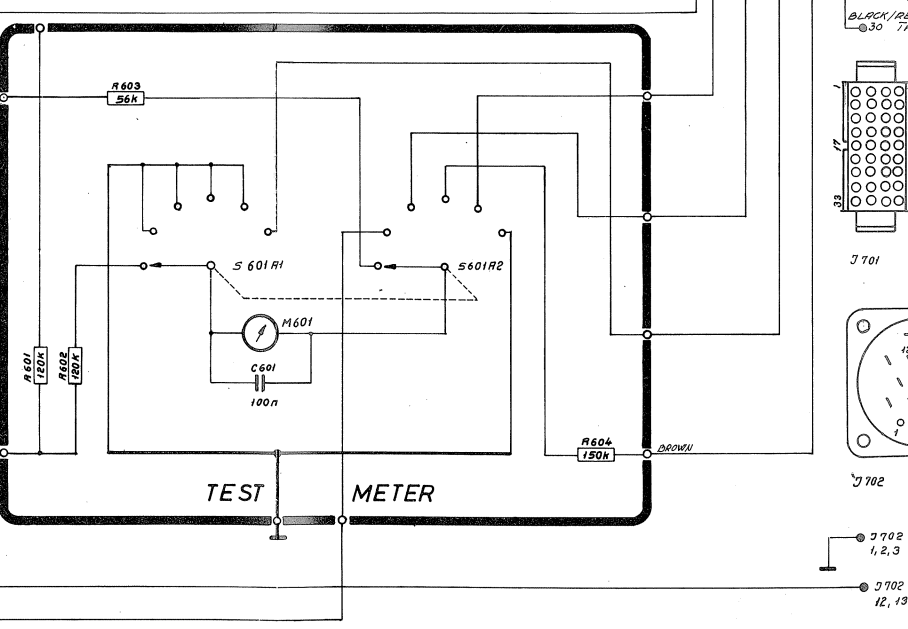
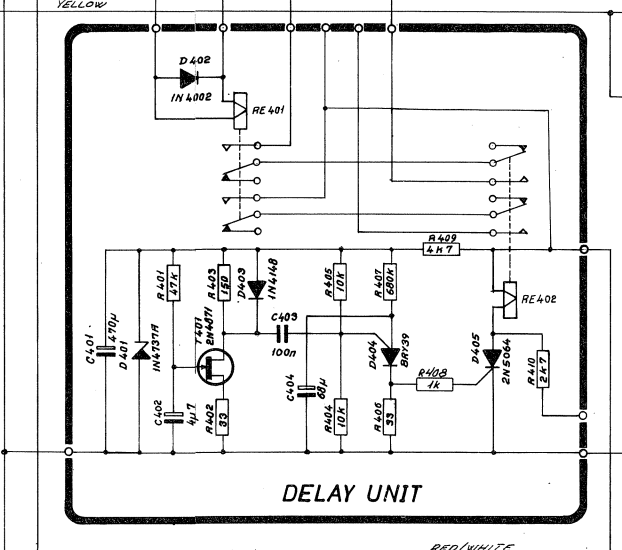
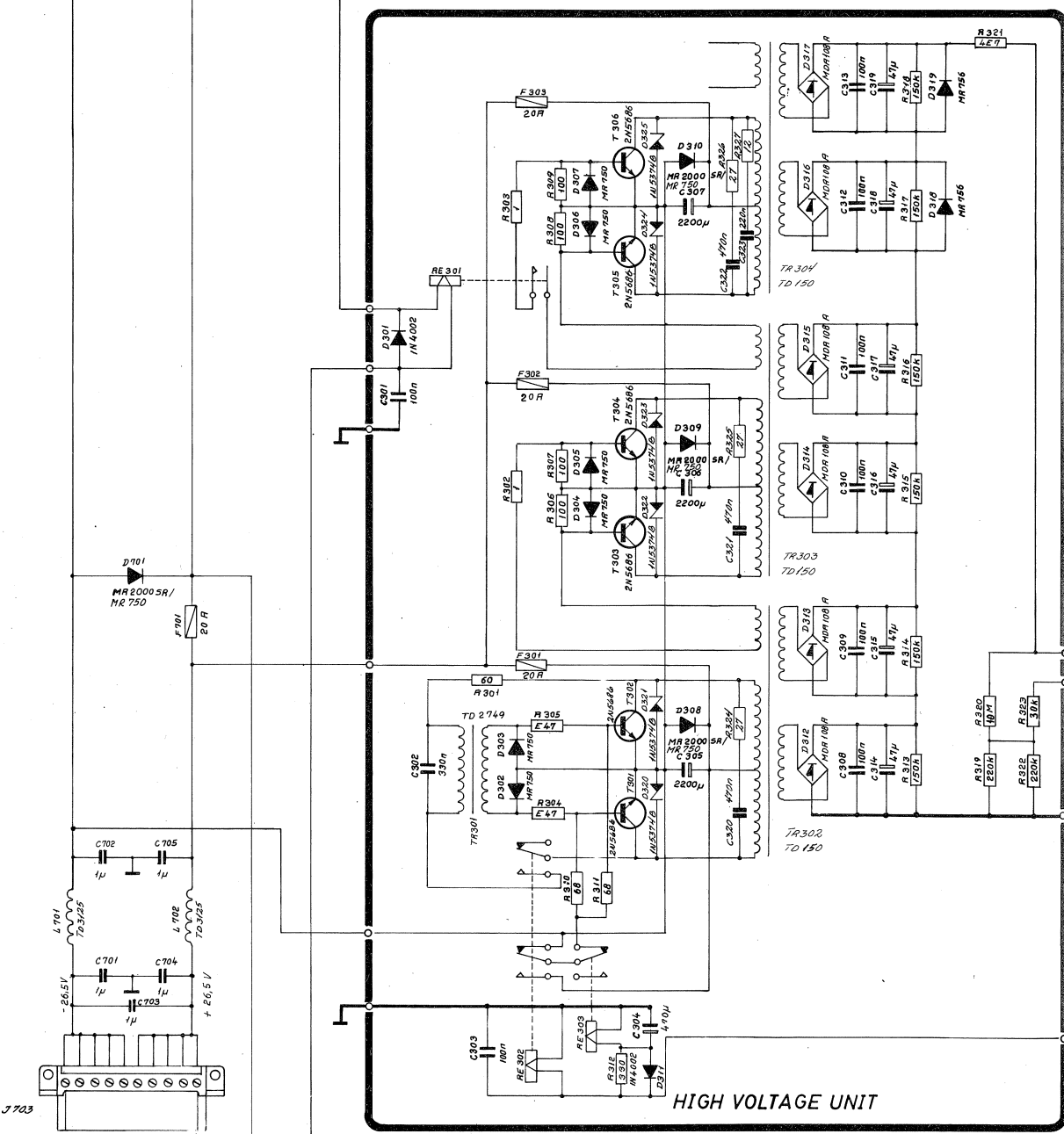
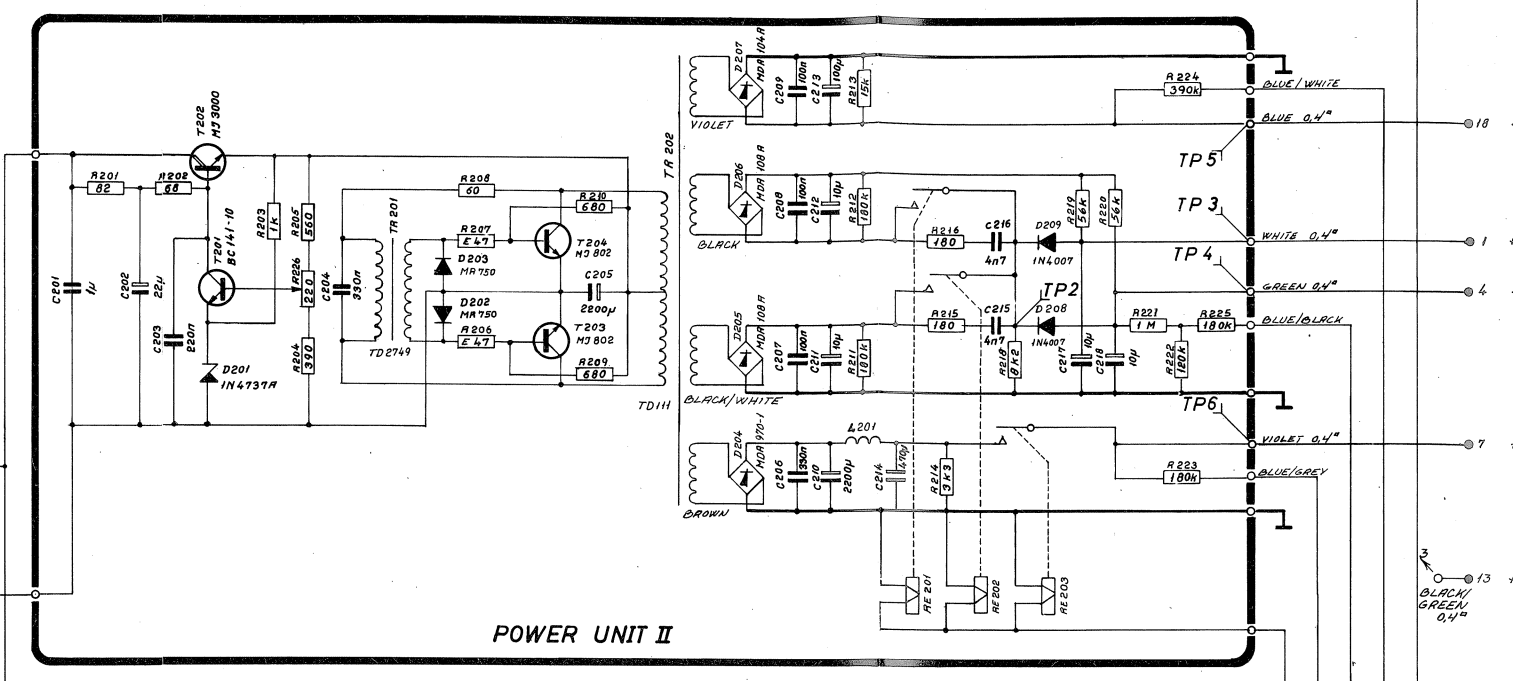
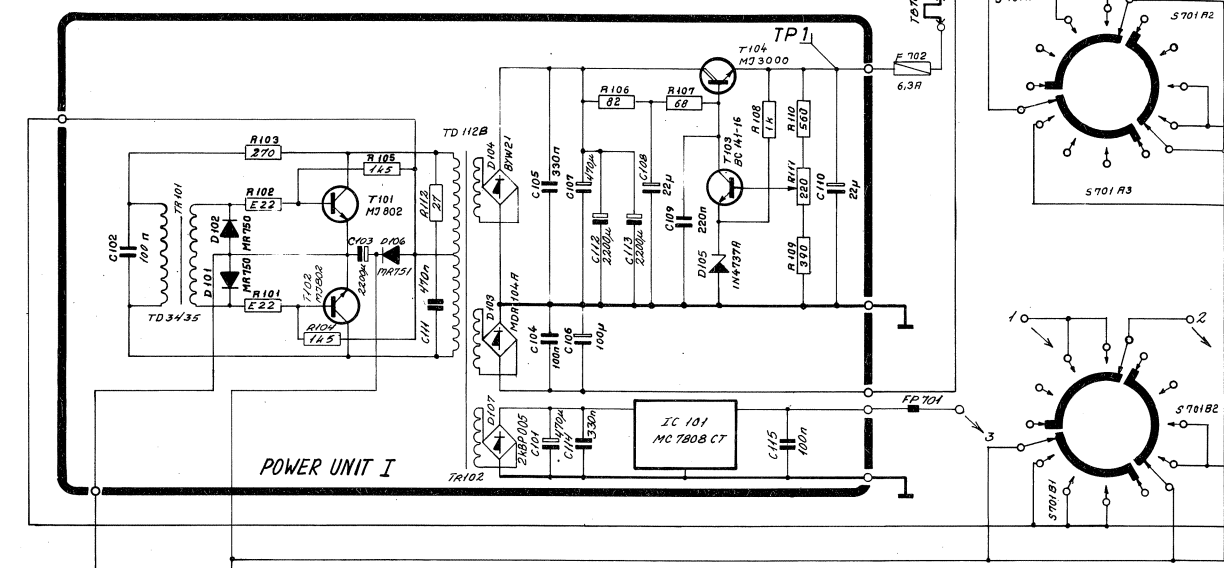

J703

SAILOR SSB N1400

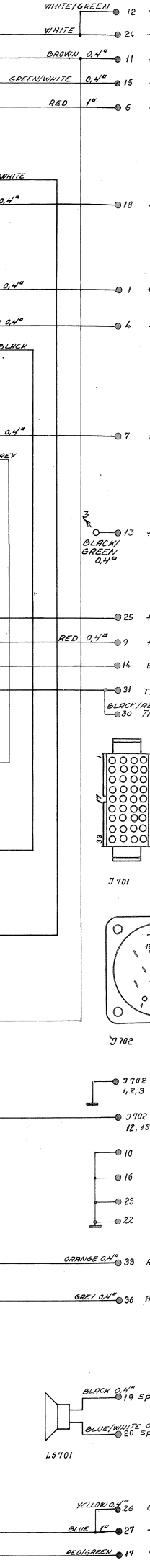



- WHITE/GREEN 12 -45 V Receiver
- WHITE 24 -45 V Exciter
- BROWN 0.4" 11 +22 V Receiver
- GREEN/WHITE 0.4" 15 +26.5 V on
- RED 1" 6 +26.5 V for Filament (Battery)

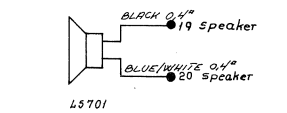
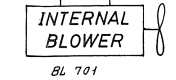
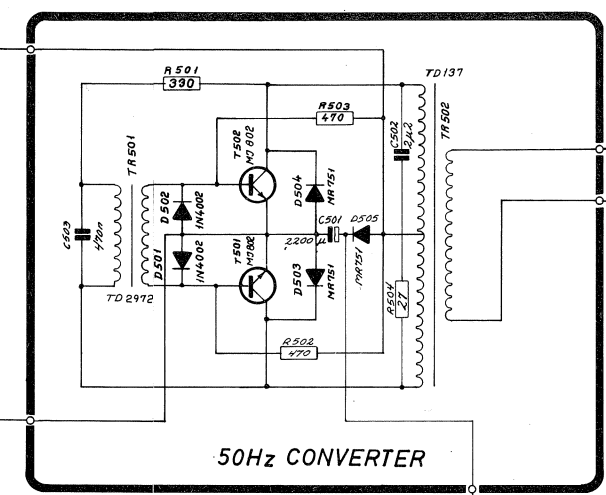
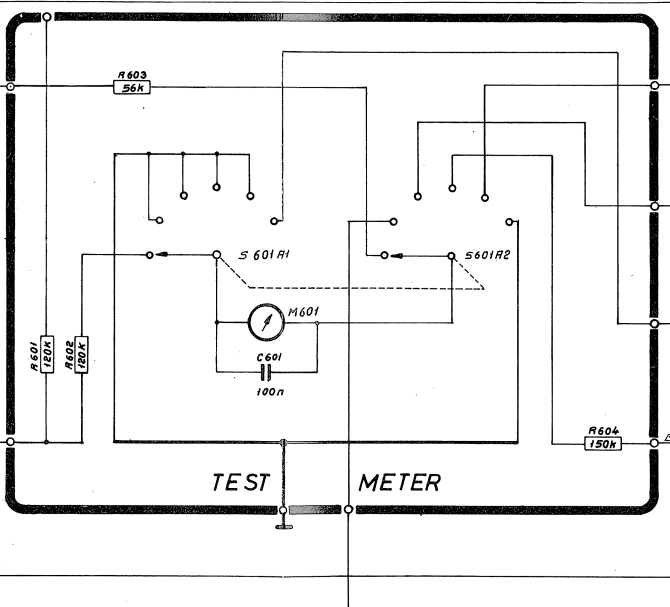
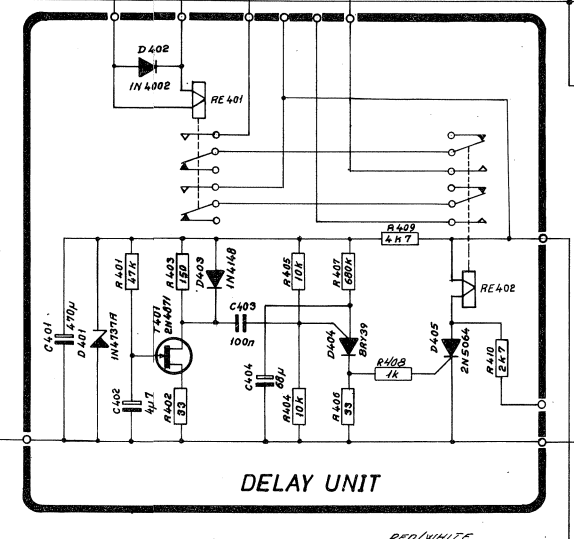
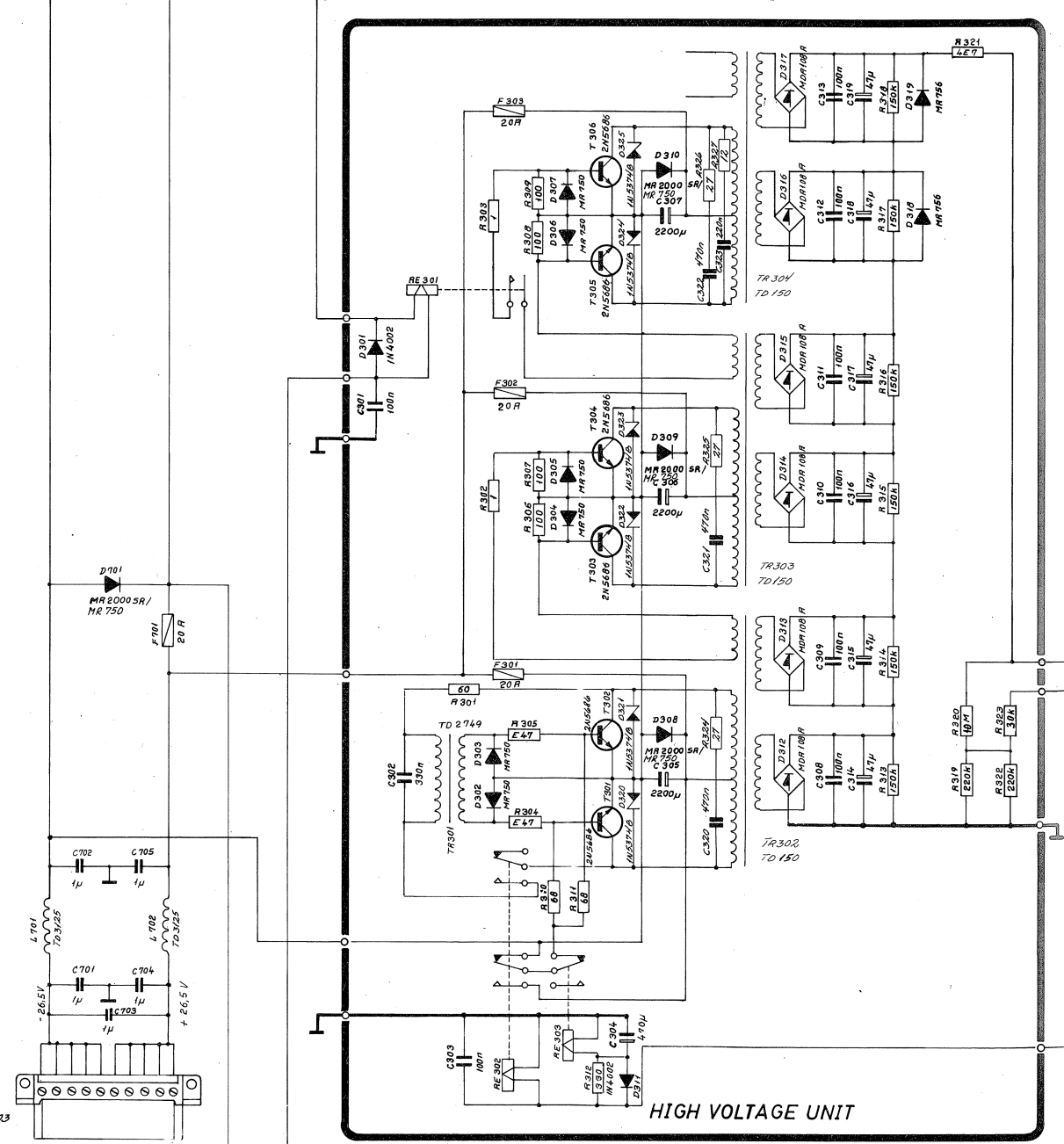
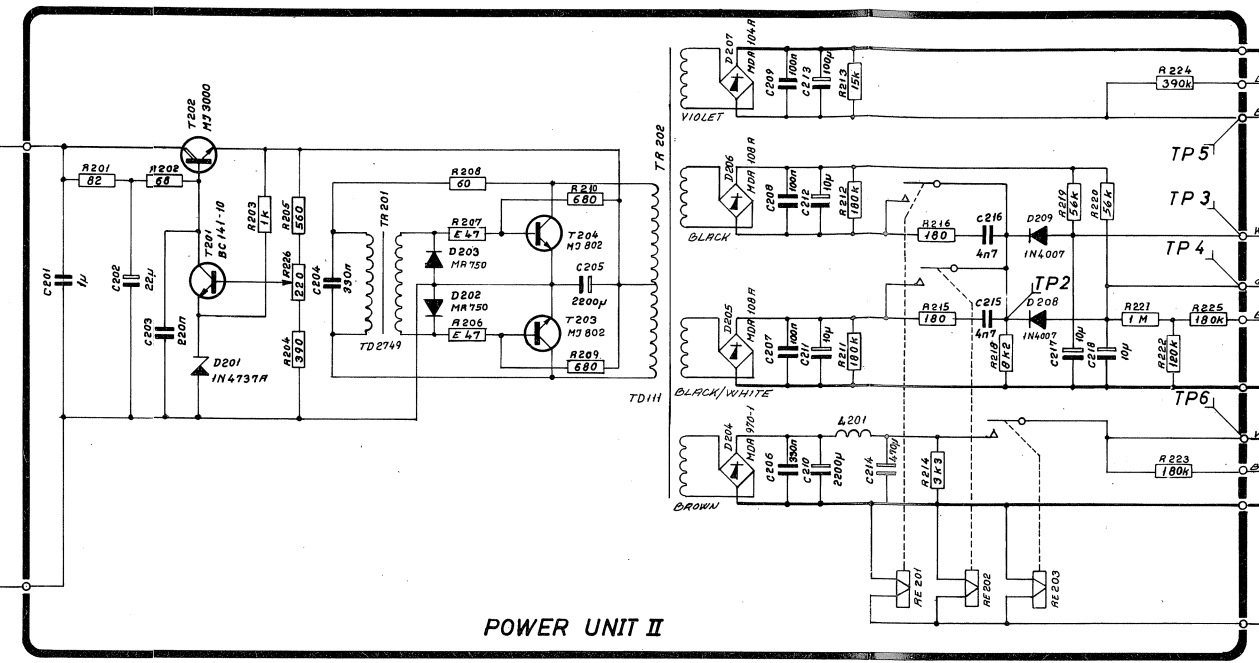
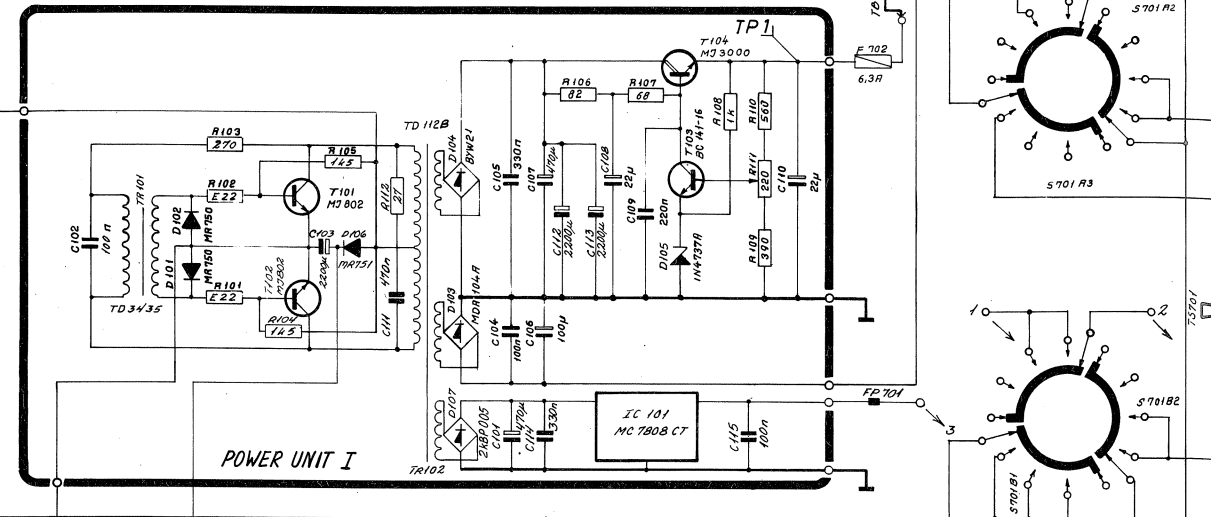

- YELLOW 0.4" 26 Ground Remote Relay (-26.5V Battery)
- BLUE 1" 27 -26.5V for Filament (Battery)
- RED/GREEN 1" 17 400/800 W Control

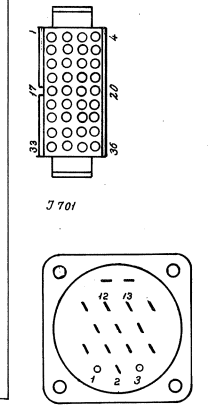

- J702 1,2,3
- J702 1400/2000V High Voltage 12, 13
- 10
- 16
- 23
- 22

- ORANGE 0.4" 33 AC Blower (220V/50Hz)
- GREY 0.4" 36 AC Blower (220V/50Hz)

SAILOR SSB N1400 (F)

