

How to change T1130/T1135 so that they will be able to work with the continuously covering exciter (S1303/4, option 1)

1. Remove pin 10 from jack D/1 and cut the wire where it goes into the cable. Insert new molex pin with wire connected in jack D/1 (pin 10). See supplement 1.
2. Remove the two wires at points A and B on the input filter unit and cut the wires where they go into the cable. Solder the new wire from jack D/1 (pin 10) on the input filter unit (point A). See supplement 2.
3. Remove the ferrit bead (FP210) on the input filter unit and insert 47 ohm resistance (R206), if it has not been done from the factory. See supplement 2.
4. Solder one end of the second wire from the kit on the input filter unit (point B). See supplement 2. The other end of the wire must be soldered on the tuner control unit. See point 6.
5. If the tuner control unit does not have the character E or a succeeding one (F, G ...) in its number (see the soldering side of the print), then you remove the unit and insert a new one from the modification kit. Remember that the battery (B501) must be moved from the old unit to the new unit and tied to the print with two cable strips. See supplement 3.
6. When soldering the wires on the new tuner control unit you must observe where the new wire from the input filter unit (point B) is to be soldered (point C). See supplement 3.
7. Tie the two new wires to the cables with the cable strips from the kit.

8. Remove IC301 from the transmitter control unit and insert new prom with the check sum 053A for T1135 and 054A for T1130. See supplement 4.
9. Remove the "drive level" sticker on top of T1130/T1135 and stick the new stickers from the kit instead.
10. When finished with the modification make a PERFORMANCE CHECK of the tuner control unit (see instruction manual) and TUNE UP the transmitter in each frequency band. See the tune up procedure in the instruction manual and supplement 5.

1130

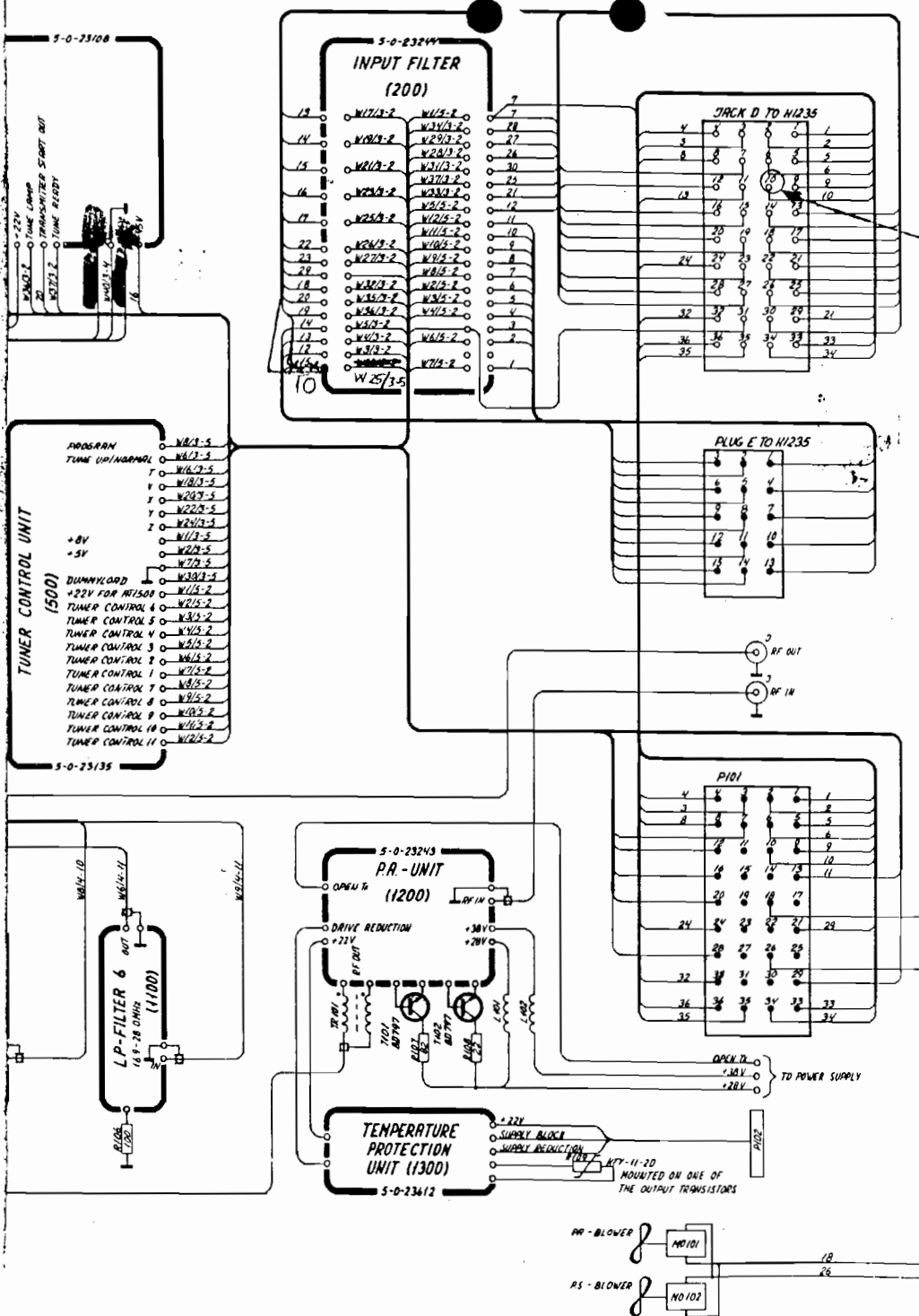

- JACK D**
- *22V TO RL
 - *8V TO RL
 - 45V TO RL
 - 22V TO RL
 - +8V TO RL
 - 45V TO RL
 - *22V FOR R11500
 - RL ON
 - GROUND TO PL
 - GROUND TO BA S
 - GROUND
 - CONTROL 3 IN
 - T
 - Y
 - X
 - Y
 - Z
 - TUNE

- TUNE LAMP
- TRANSMITTER START
- BLOCK
- DRIVE LEVEL/REG
- DRIVE LEVEL
- MT ON
- TUNE READY
- METER *
- METER *
- OPEN FL BLOCK
- OPEN FL
- DUMMY LOAD
- CONTROL 3 TO R11500
- OFF
- *BAT
- *22V
- ON
- 45V

- PLUG E**
- TUNER CONTROL 1
 - TUNER CONTROL 2
 - TUNER CONTROL 3
 - TUNER CONTROL 4
 - TUNER CONTROL 5
 - TUNER CONTROL 6
 - TUNER CONTROL 7
 - TUNER CONTROL 8
 - TUNER CONTROL 9
 - TUNER CONTROL 10
 - TUNER CONTROL 11
 - INVALID TUNING/180°
 - MOTOR/REAR CURRENT
 - REAR CURRENT
 - ~~POWER DOWN FROM POWER SUPPLY~~

- P101**
- 22V TO RL
 - +8V TO RL
 - 45V TO RL
 - 22V TO RL
 - +8V TO RL
 - 45V TO RL
 - *22V FOR R11500
 - RL ON
 - GROUND TO RL
 - GROUND TO BA
 - POWER DOWN FROM POWER SUPPLY
 - GROUND
 - GROUND
 - OFF
 - *BAT
 - *22V
 - ON
 - 45V

- TRANSMITTER START
- OPEN FL
- DRIVE LEVEL/REG
- MT ON
- BLOWER
- *22V TO T1130
- +8V TO T1130
- OFF
- *BAT
- *22V
- ON
- 45V

- P102**
- 22V
 - SUPPLY BLOCK
 - SUPPLY REDUCTION

SUPPLEMENT 1 - T1130
 MAIN SCHEMATIC DIAGRAM
 FOR
 SAILOR TRANSMITTER T1130 (D)

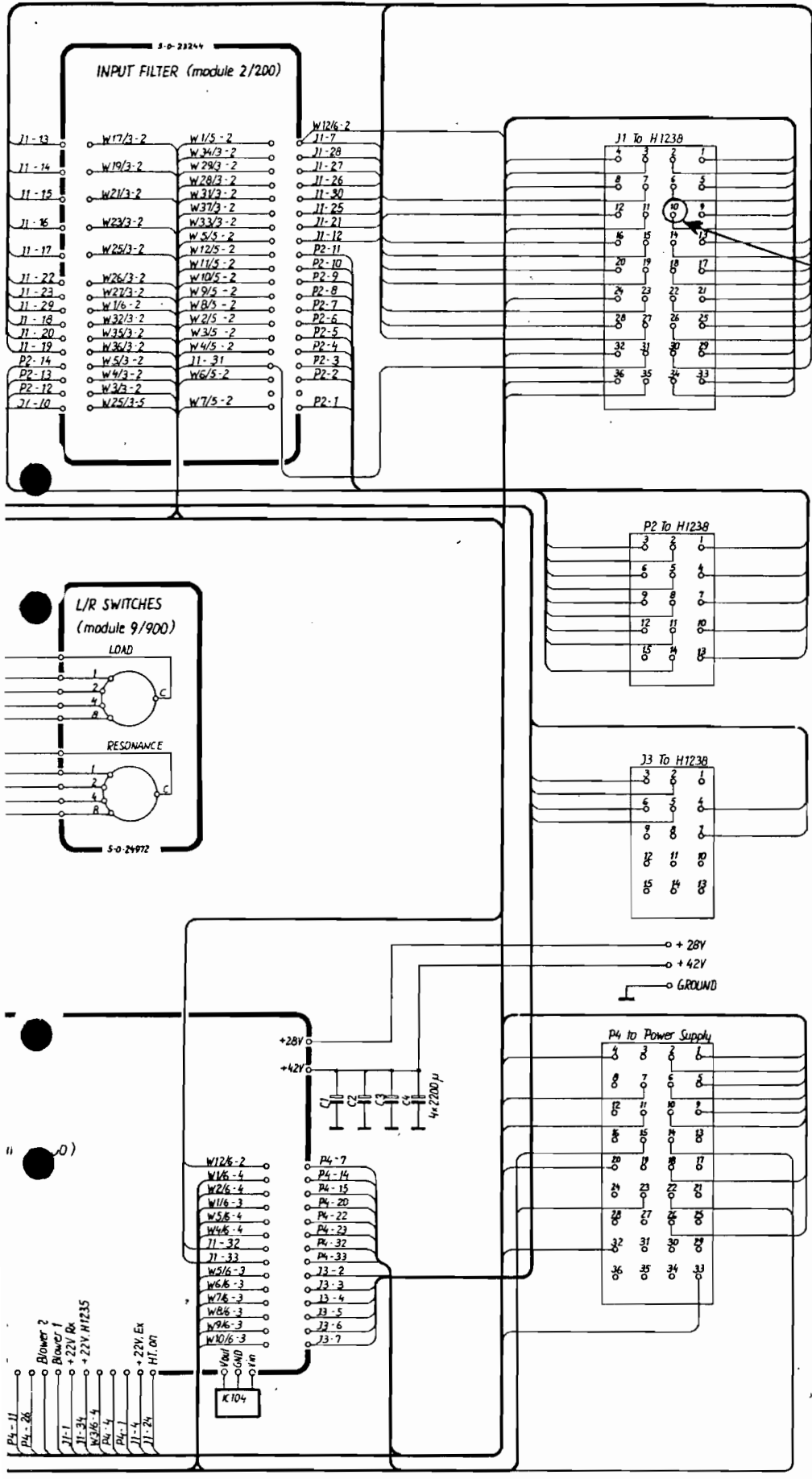

- Jack 1**
- | | |
|----|-----------------|
| 1 | + 22V to Rx |
| 2 | + 8V to Rx |
| 3 | - 45V to Rx |
| 4 | + 22V to Ex |
| 5 | + 8V to Ex |
| 6 | - 45V to Ex |
| 7 | + 22V to AT150S |
| 8 | Bx on |
| 9 | GROUND to Rx |
| 10 | S |
| 11 | GROUND |
| 12 | Control 3in |
| 13 | T |
| 14 | V |
| 15 | X |
| 16 | Y |
| 17 | Z |
| 18 | Tune |

- | | |
|----|----------------------|
| 19 | Tune Lamp |
| 20 | TRANSMITTER start |
| 21 | Block |
| 22 | Drive level/reg |
| 23 | Drive level |
| 24 | HT on |
| 25 | Tune ready |
| 26 | Meter |
| 27 | Meter + |
| 28 | Ext. Is. Block |
| 29 | Open Is |
| 30 | Dummy load |
| 31 | Control 3 to AT 150S |
| 32 | Start PU 1 |
| 33 | +Aoff |
| 34 | +22V |
| 35 | On |
| 36 | -45V |

- Plug 2**
- | | |
|----|------------------|
| 1 | TUNER control 1 |
| 2 | TUNER control 2 |
| 3 | TUNER control 3 |
| 4 | TUNER control 4 |
| 5 | TUNER control 5 |
| 6 | TUNER control 6 |
| 7 | TUNER control 7 |
| 8 | TUNER control 8 |
| 9 | TUNER control 9 |
| 10 | TUNER control 10 |

- | | |
|----|------------------------|
| 11 | TUNER control 11 |
| 12 | Inverted tuning / 180° |
| 13 | Motor/Aerial current |
| 14 | Aerial current |
| 15 | |

- Jack 3**
- | | |
|----|------------------|
| 1 | FILTER 7 control |
| 2 | FILTER 8 control |
| 3 | FILTER 4 control |
| 4 | FILTER 5 control |
| 5 | FILTER 6 control |
| 6 | + 22V |
| 7 | |
| 8 | |
| 9 | |
| 10 | |

- | | |
|----|--|
| 11 | |
| 12 | |
| 13 | |
| 14 | |
| 15 | |

- Plug 4 to POWER SUPPLY**
- | | |
|----|-------------------|
| 1 | + 22V |
| 2 | Supply for 8V Res |
| 3 | |
| 4 | + 22V |
| 5 | Supply for 8V Res |
| 6 | - 45V |
| 7 | + 22V to AT150S |
| 8 | |
| 9 | GROUND |
| 10 | Blower I |
| 11 | Blower II |
| 12 | |
| 13 | |
| 14 | Supply Production |
| 15 | Supply Block |
| 16 | |
| 17 | |
| 18 | Blower I |

- | | |
|----|-----------------------|
| 19 | |
| 20 | TRANSMITTER start out |
| 21 | |
| 22 | -3dB |
| 23 | AC/DC |
| 24 | |
| 25 | |
| 26 | Blower II |
| 27 | |
| 28 | |
| 29 | |
| 30 | |
| 31 | |
| 32 | Start PU 1 |
| 33 | + Blower |
| 34 | |
| 35 | |
| 36 | |

MG 103 Rock Blower

⊙ J5 RF in

⊙ J6 RF out

MAIN SCHEMATIC DIAGRAM T1135 (B)

T1130/T1135
4-0-23244C, 4-6-23244

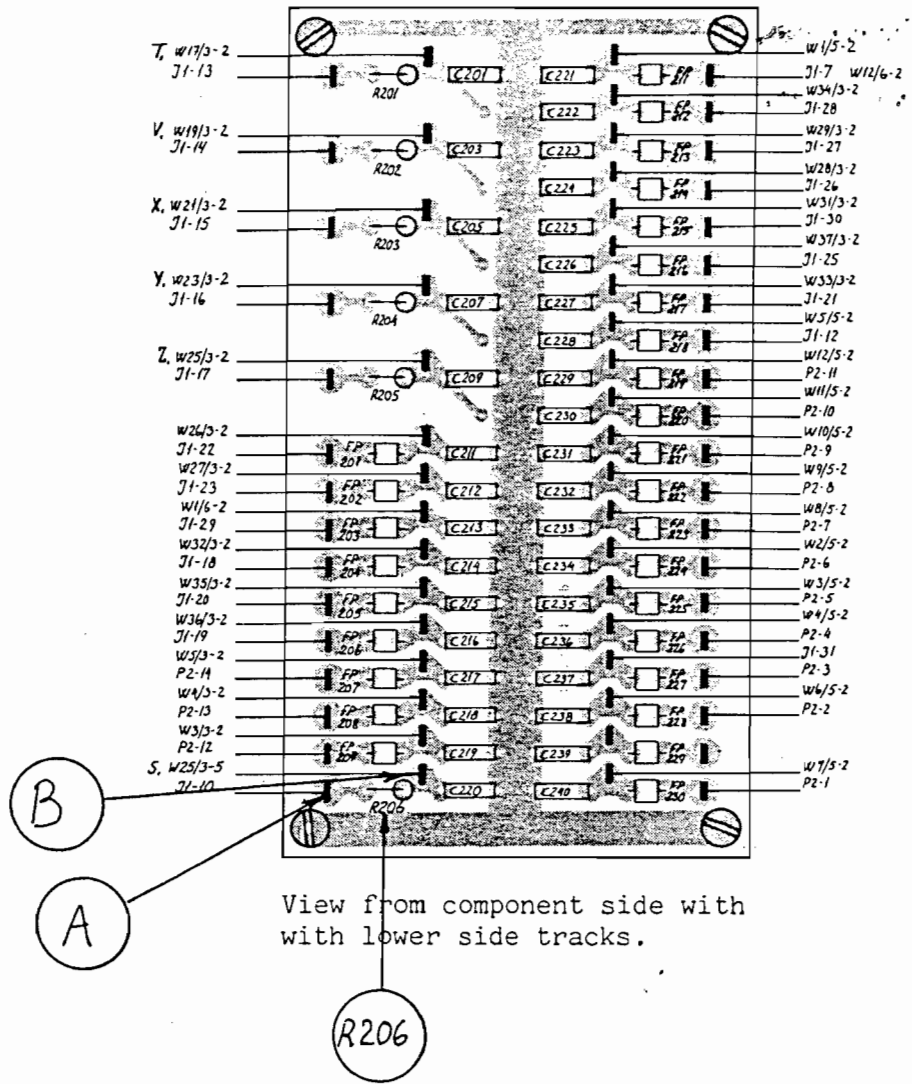

SUPPLEMENT 2.

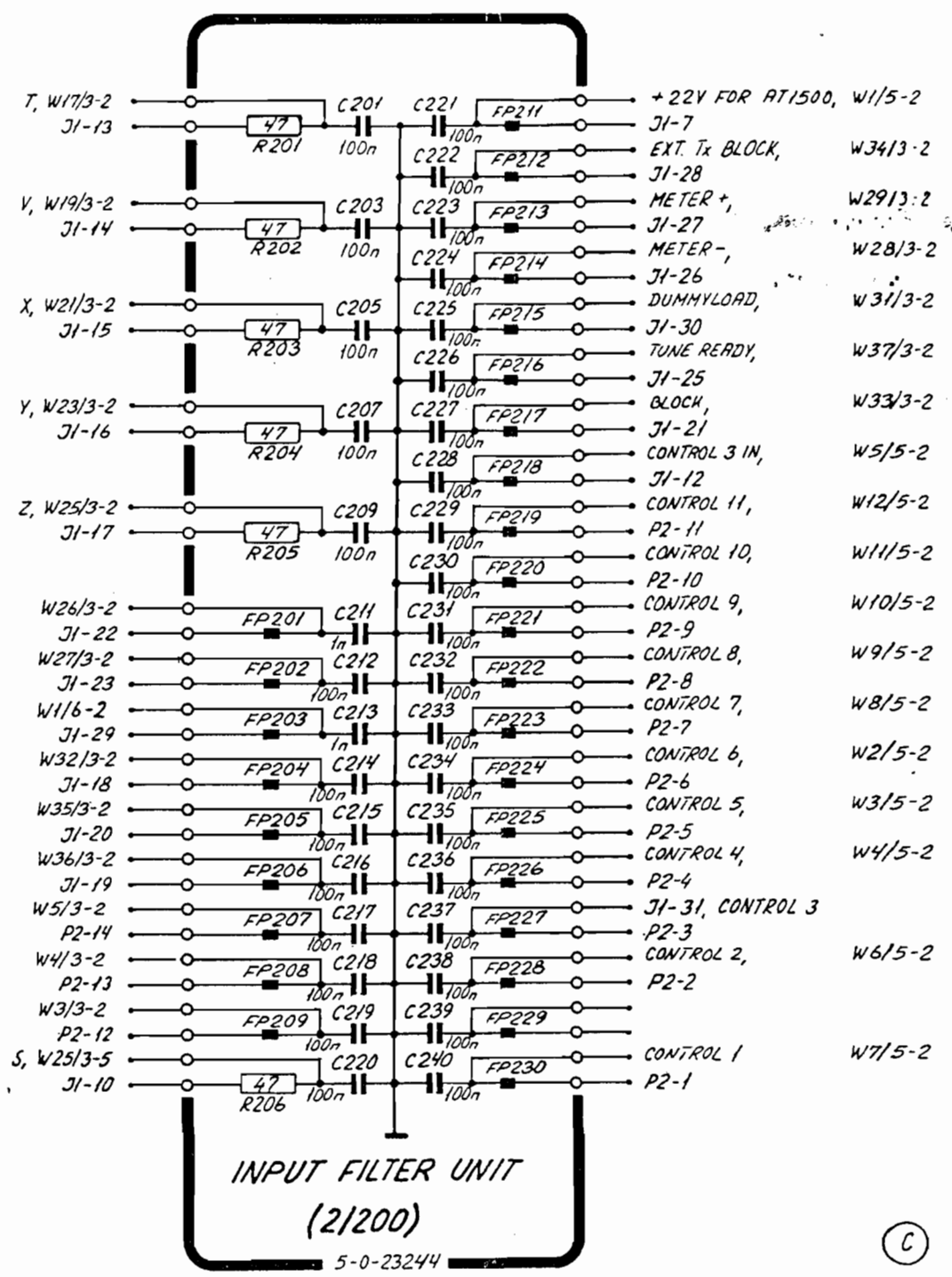

- DRIVE LEVEL/REG,
- DRIVE LEVEL,
- OPEN Tx,
- TUNE,
- TRANSMITTER START,
- TUNE LAMP,
- AERIAL CURRENT,
- MOTOR/AERIAL CURRENT,
- INVALID TUNING /180°,

INPUT FILTER UNIT
(2/200)

5-0-23244

(C)

TUNER CONTROL UNIT (MODULE 5/500)

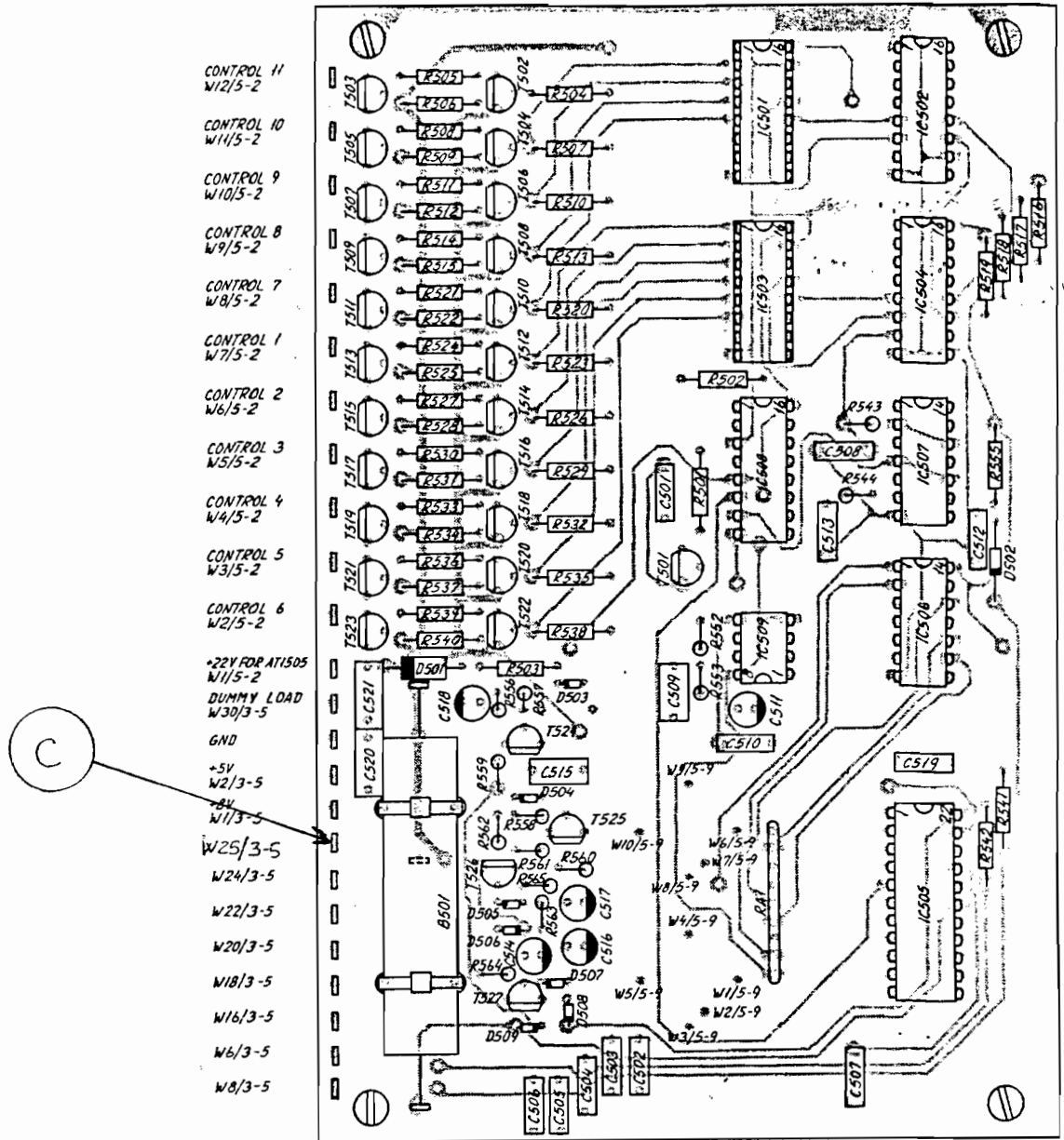

View from component side with upper side tracks.

L/R SWITCHES (MODULE 9/900)

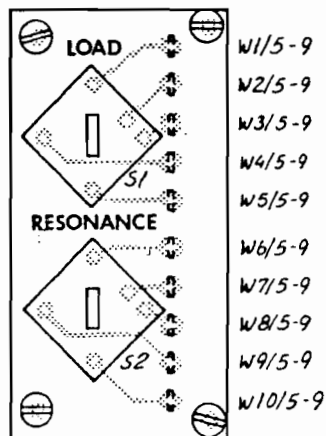

View from component side with lower side tracks.

SUPPLEMENT 3.

TUNER CONTROL UNIT (MODULE 5/500)

L/R SWITCHES (MODULE 9/900)

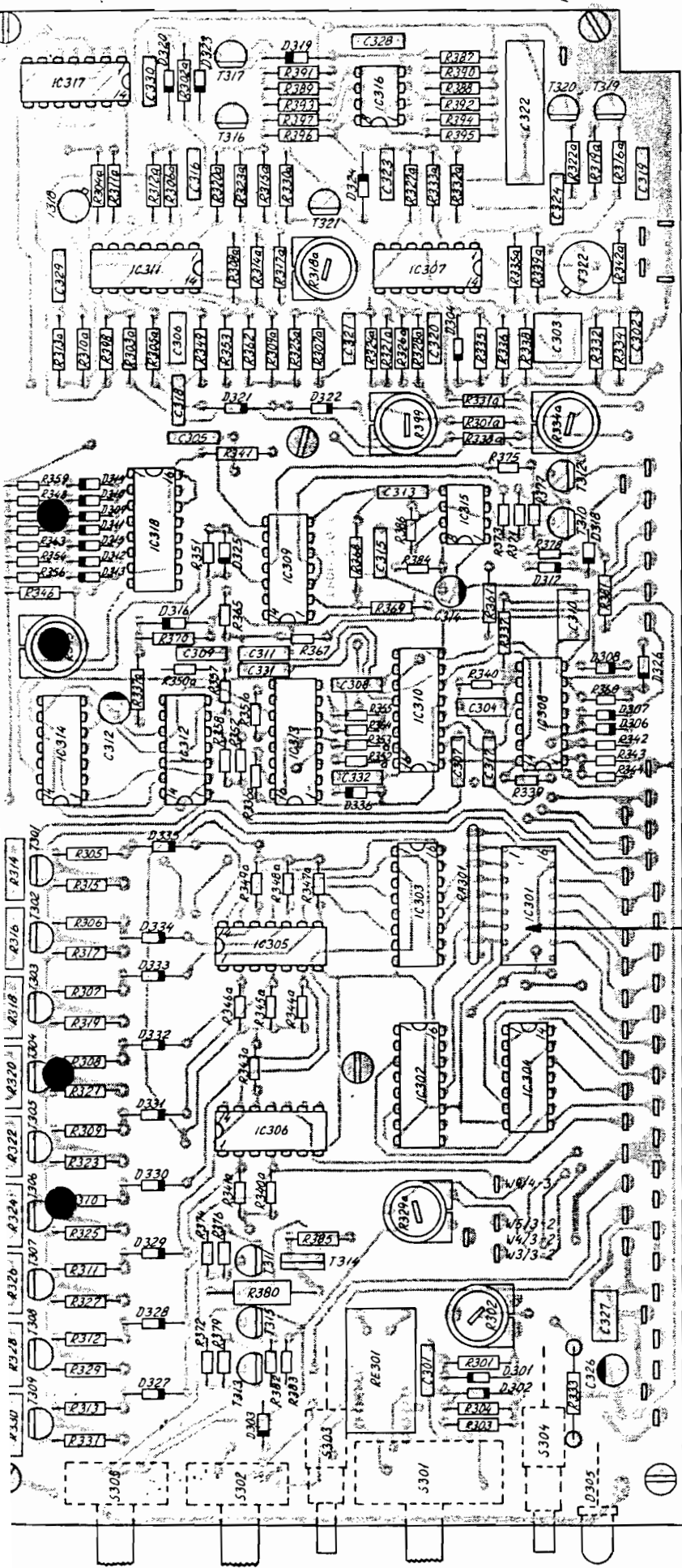

GROUND
W39/3-4, VR
W41/3-4, VF
GROUND

W37/3-2
20
W36/3-2
+22V
W35/3-2
W34/3-2
W33/3-2

W32/3-2

W31/3-2
W30/3-5
W29/3-2
W28/3-2
W27/3-2
W26/3-2
W25/3-2
W24/3-5
W23/3-2
W22/3-5
W21/3-2
W20/3-5
W19/3-2
W18/3-5
W17/3-2
W16/3-5
W15/3-5
W14/3-3
W13/3-5
W12/3-5
W11/3-5

IC301

+5V
GROUND
+8V
W42/3-4
GROUND
+22V IN

T1135
4-6-23108J

ew from component side with lower side tracks.

SUPPLEMENT 4.

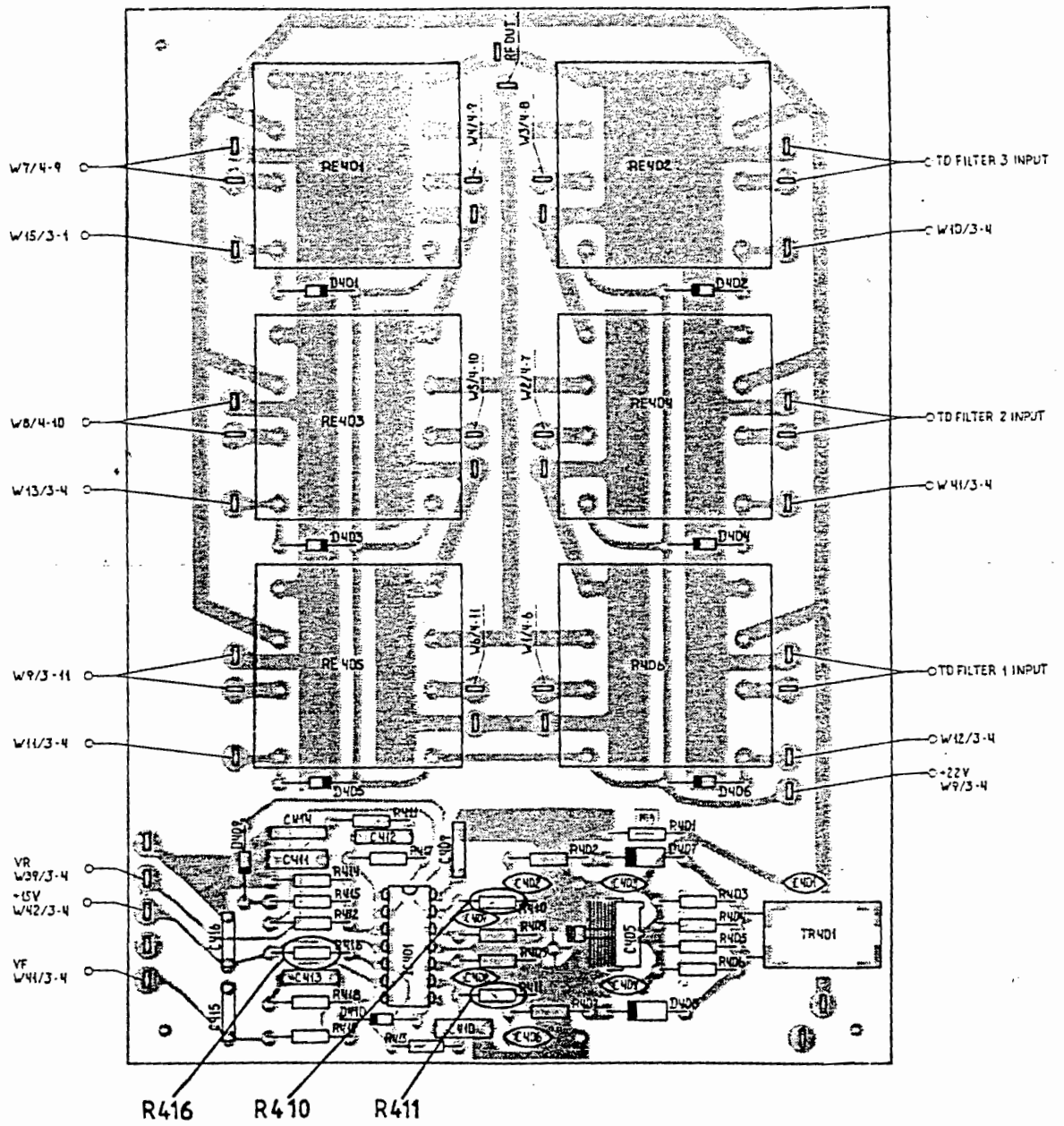

TABLE 2. VALID FOR T1130 WITH SERIAL NUMBER HIGHER THAN 20000

This table is based on several aerial measurements, but is must only be considered as a guide.

To make the table more complete it is most important that you fill in the TUNING TABLE FOR T1130 in the back of this manual and return it to S. P. Radio.

If it is not possible to tune the transmitter within the resonance and load numbers listed in table 2, then use TABLE 2a.

AERIAL LENGTH T1130																				
FREQUENCY BANDS in T1130 kHz	5-6 m		7 m		8 m		9 m		10 m		11 m		12 m		13 m		14 m		15 m	
	Reso- nance	Load	Reso- nance	Load	Reso- nance	Load	Reso- nance	Load	Reso- nance	Load	Reso- nance	Load	Reso- nance	Load	Reso- nance	Load	Reso- nance	Load	Reso- nance	Load
1600.0 - 1799.9	0-3	1	0-3	1	4-6	1	4-6	1	4-6	0-1	4-6	0-1	4-6	0-1	4-6	0	4-6	0	4-6	0
1800.0 - 1999.9	0-3	1	0-3	1	4-6	0-1	4-6	0-1	4-6	0	4-6	0	4-6	0	4-6	0	4-6	0	4-6	0
2000.0 - 2199.9	0-3	0	0-3	0	4-6	0	4-6	0	4-6	0	4-6	0	4-6	0	4-6	0	4-6	0	4-6	0
2200.0 - 2399.9	0-3	0	0-3	0	4-6	0	4-6	0	4-6	0	4-6	0	4-6	0	4-6	0	4-6	0	4-6	0
2400.0 - 2599.9	0-3	0	0-3	0	4-6	0	4-6	0	4-6	0	4-6	0	4-6	0	4-7	0	4-7	0	4-7	0
2600.0 - 2799.9	0-3	0	0-3	0	4-6	0	4-6	0	4-6	0	4-6	0	4-6	0	4-7	0-1	4-7	0-1	4-7	0-1
2800.0 - 2999.9	0-3	0	0-3	0	4-7	0	4-7	0	4-7	0	4-7	0	4-7	0	4-7	0-1	4-7	0-1	4-7	0-1
3000.0 - 3099.9	0-3	0	0-3	0	4-7	0	4-7	0	4-7	0	4-7	0	4-7	0	4-7	0-1	4-7	0-1	4-7	0-1
3100.0 - 3399.9	0-3	0	0-3	0	4-7	0	4-7	0	4-7	0	4-7	0	4-7	0	4-7	0-1	4-7	0-1	4-7	0-1
3400.0 - 3699.9	0-3	0	0-3	0	4-7	0	4-7	0	4-7	0-1	4-7	0-1	4-7	0-1	4-7	0-1	4-7	1-2	4-7	1-2
3700.0 - 3999.9	1-3	0	1-3	0	4-7	0-1	4-7	0-1	4-7	0-1	4-7	0-2	4-7	0-2	4-7	0-3	4-7	0-3	4-7	0-4
4000.0 - 4299.9	1-3	0	1-3	0	5-7	0-2	5-7	0-2	5-7	0-2	5-7	0-2	5-7	0-2	5-8	0-3	5-8	1-7	5-8	1-7
4300.0 - 4599.9	4-7	0-4	4-7	0-3	5-7	0-2	5-7	0-2	5-8	0-2	5-8	0-2	5-8	0-2	5-8	0-3	5-8	1-8	5-8	1-9
4600.0 - 4999.9	4-7	0-1	4-7	0-3	5-7	0-2	5-8	0-2	5-8	0-2	5-8	0-2	5-8	0-3	5-9	7-10	5-9	7-10	6-9	7-10
5000.0 - 5499.9	5-7	0-1	5-7	0-3	6-8	0-2	6-8	0-2	6-9	2-5	6-9	5-10	6-9	5-10	6-9	5-10	6-9	5-10	6-9	2-5
5500.0 - 5999.9	6-8	0-1	5-8	0-3	6-8	0-2	6-9	1-3	6-9	5-10	6-9	5-10	6-10	5-10	6-9	5-10	6-9	2-6	6-9	2-6
6000.0 - 6399.9	6-9	0-4	4-9	0-3	6-9	0-3	6-9	1-5	6-9	5-9	7-9	5-9	7-9	5-10	7-9	4-8	7-9	4-8	7-9	4-8
6400.0 - 6999.9	6-9	0-4	6-9	0-5	6-9	3-8	6-9	4-8	6-9	5-9	7-9	4-8	7-9	4-8	7-9	4-8	7-9	4-8	7-9	3-6
7000.0 - 7599.9	6-10	0-4	6-10	0-5	6-9	3-8	6-9	4-8	6-9	4-8	7-9	3-6	7-9	4-8	7-9	4-8	7-9	4-8	7-9	2-5
7600.0 - 7999.9	6-11	0-4	6-11	0-5	6-9	3-8	6-9	4-8	6-9	4-8	6-9	2-6	7-9	2-6	7-9	2-6	7-9	2-6	7-9	2-4
8000.0 - 8499.9	9-11	0-4	9-11	0-5	6-9	3-6	6-9	3-6	6-9	4-8	6-9	1-4	7-9	1-4	7-9	1-4	7-9	1-4	7-9	2-4
8500.0 - 8999.9	6-11	0-4	6-11	0-8	7-10	3-6	7-10	3-6	7-10	2-6	7-10	2-5	7-10	1-4	7-10	1-4	7-10	1-4	7-10	1-4
9000.0 - 9499.9	7-11	0-4	7-11	0-8	7-11	3-6	7-11	3-6	7-10	2-6	7-10	2-5	7-10	1-4	7-10	1-4	7-10	1-4	7-10	1-4
9500.0 - 9999.9	8-12	0-4	8-12	0-8	7-11	3-6	7-11	2-5	7-11	1-4	7-11	1-4	7-11	1-4	7-10	0-3	7-10	0-3	7-10	0-3
10000.0 - 10499.9	8-12	0-4	8-12	0-8	7-11	2-5	7-11	2-5	7-11	1-4	7-11	1-4	7-11	0-3	7-11	0-3	7-11	0-3	7-11	0-3
10500.0 - 10999.9	9-12	0-4	9-12	0-8	7-11	1-4	7-11	1-4	7-11	1-4	7-11	0-3	7-11	0-3	7-11	10-3	7-11	0-3	7-11	0-3

TABLE 2 continued

FREQUENCY BANDS in T1130 kHz	AERIAL LENGTH T1130																			
	5-6 m		7 m		8 m		9 m		10 m		11 m		12 m		13 m		14 m		15 m	
	Reso- nance	Load	Reso- nance	Load	Reso- nance	Load	Reso- nance	Load	Reso- nance	Load	Reso- nance	Load	Reso- nance	Load	Reso- nance	Load	Reso- nance	Load	Reso- nance	Load
11000.0 - 11499.9	9-12	0-5	9-12	0-8	8-11	0-3	8-11	0-3	8-11	0-3	8-11	0-3	8-11	0-3	8-11	0-3	8-11	0-3	8-11	0-3
11500.0 - 11999.9	9-12	0-5	9-12	0-7	8-11	0-3	8-11	0-3	8-11	0-3	8-11	0-3	8-11	0-3	8-11	0-3	8-11	0-3	8-11	0-4
12000.0 - 12499.9	10-12	3-6	10-12	1-5	10-13	0-4	10-13	0-4	10-13	0-4	10-13	0-4	10-13	0-5	10-13	0-5	10-13	0-5	10-13	0-5
12500.0 - 12999.9	10-13	0-4	10-13	0-7	10-13	0-4	10-13	0-4	10-13	0-4	10-13	0-4	10-13	0-5	10-13	0-5	10-13	0-5	10-13	0-5
13000.0 - 13499.9	10-13	0-4	10-13	0-7	10-13	0-4	10-13	0-4	10-13	0-4	10-13	0-4	10-13	0-5	10-13	0-5	10-13	0-5	10-13	0-5
13500.0 - 13999.9	10-13	0-4	10-13	0-7	10-13	0-4	10-13	0-4	10-13	0-4	10-13	0-4	10-13	0-5	10-13	0-5	10-13	0-5	10-13	0-5
14000.0 - 14499.9	10-13	0-4	10-13	0-7	10-13	0-4	10-13	0-4	10-13	0-4	10-13	0-4	10-13	0-5	10-13	1-6	11-13	1-6	11-13	0-5
14500.0 - 14999.9	10-13	0-4	10-13	0-7	10-13	0-4	10-13	0-4	10-13	0-4	10-13	0-4	11-13	0-5	11-13	1-6	11-13	1-6	11-13	1-6
15000.0 - 15599.9	11-14	0-4	11-14	0-7	11-13	0-4	11-13	1-5	11-13	1-5	11-13	1-5	11-13	0-5	11-13	1-6	11-13	1-6	11-13	1-6
15600.0 - 15999.9	11-14	0-3	11-14	0-7	11-13	1-5	11-13	1-5	11-13	1-5	11-13	1-5	11-13	1-6	11-13	1-6	12-14	1-5	12-14	1-5
16000.0 - 16499.9	11-14	0-3	11-14	0-7	11-13	1-5	11-13	1-5	11-13	1-5	11-13	1-5	12-14	1-6	12-14	2-5	12-14	1-5	12-14	1-5
16500.0 - 16999.9	11-13	0-2	11-13	0-2	11-13	1-5	11-13	1-4	11-13	1-4	11-13	1-4	12-14	2-5	12-14	2-5	12-14	1-5	12-14	1-5
17000.0 - 17499.9	11-14	0-3	11-14	0-7	11-13	1-5	11-13	1-4	11-14	1-4	11-14	2-5	12-14	2-5	12-14	2-5	11-14	1-5	11-14	1-5
17500.0 - 17999.9	11-14	0-3	11-14	0-7	11-13	1-4	11-13	1-4	11-14	2-5	11-14	2-6	12-14	2-5	12-14	1-5	12-14	0-4	12-14	0-4
18000.0 - 18999.9	11-14	0-3	11-14	0-6	11-13	0-4	12-15	0-4	11-14	2-5	11-14	1-5	12-14	1-5	12-14	1-4	12-14	0-4	12-14	0-4
19000.0 - 19999.9	12-14	0-3	12-14	0-6	12-14	0-4	12-15	0-4	12-15	2-5	11-14	1-5	12-14	1-5	12-14	1-4	12-14	0-4	12-14	0-4
20000.0 - 20999.9	13-15	0-3	13-15	0-6	13-15	0-4	13-15	0-4	12-15	1-5	11-14	0-5	12-14	0-5	12-14	0-4	12-14	0-4	12-15	0-4
21000.0 - 21999.9	13-15	0-3	13-15	0-5	13-15	0-4	13-15	0-4	12-15	0-4	12-15	0-4	12-15	0-4	12-15	0-4	12-15	0-4	13-15	0-4
22000.0 - 22999.9	14-15	1-3	14-15	1-3	14-15	1-4	14-15	1-4	14-15	1-4	14-15	1-4	14-15	1-4	14-15	1-4	14-15	1-4	14-15	1-4
23000.0 - 23999.9	14-15	0-3	14-15	0-4	14-15	1-4	14-15	0-4	14-15	0-4	14-15	0-4	14-15	0-4	14-15	0-4	14-15	0-4	14-15	0-4
24000.0 - 24999.9	14-15	0-3	14-15	0-4	14-15	0-4	14-15	0-4	14-15	0-4	14-15	0-4	14-15	0-4	14-15	0-4	14-15	0-4	14-15	0-4
25000.0 - 25999.9	14-15	0-3	14-15	0-3	14-15	0-4	14-15	0-4	14-15	0-4	14-15	0-4	14-15	0-4	14-15	0-4	14-15	0-4	14-15	0-4
26000.0 - 26999.9	14-15	0-3	14-15	0-4	14-15	0-4	14-15	0-4	14-15	0-4	14-15	0-4	14-15	0-4	14-15	0-4	14-15	0-4	14-15	0-4
27000.0 - 27999.9	14-15	0-4	14-15	0-4	14-15	0-4	14-15	0-4	14-15	0-4	14-15	0-4	14-15	0-4	14-15	0-4	14-15	0-4	14-15	0-4
Fixed 2182	0-3	0	0-3	0	4-6	0	4-6	0	4-6	0	4-6	0	4-6	0	4-6	0	4-6	0	4-6	0

SUPPLEMENT 5 T 1130

TABLE 2a. VALID FOR T1130 WITH SERIAL NO. HIGHER THAN 261800.

The table covers all permitted RESONANCE and LOAD numbers.

FREQUENCY BANDS IN T1130 kHz	AERIAL LENGTH			
	5-8 m		9-15 m	
	Reso- nance	Load	Reso- nance	Load
1600.0 - 1799.9	0-3	0-1	4-7	0-1
1800.0 - 1999.9	0-3	0-1	4-7	0-1
2000.0 - 2199.9	0-3	0-1	4-7	0-1
2200.0 - 2399.9	0-3	0-1	4-7	0-1
2400.0 - 2599.9	0-3	0-1	4-7	0-1
2600.0 - 2799.9	0-3	0-2	4-7	0-2
2800.0 - 2999.9	0-3	0-2	4-7	0-2
3000.0 - 3099.9	0-3	0-2	4-7	0-2
3100.0 - 3399.9	0-3	0-6	4-7	0-6
3400.0 - 3699.9	0-3	0-6	4-7	0-6
3700.0 - 3999.9	0-3	0-6	4-7	0-6
4000.0 - 4299.9	1-3	0-10	5-7	0-10
4300.0 - 4599.9	4-7	0-10	5-7	0-10
4600.0 - 4999.9	4-7	0-10	5-7	0-10
5000.0 - 5499.9	5-7	0-9	5-7	0-9
5500.0 - 5999.9	5-8	0-9	5-8	0-9
6000.0 - 6399.9	6-9	0-9	6-9	0-9
6400.0 - 6999.9	6-9	0-9	6-9	0-9
7000.0 - 7599.9	6-10	0-9	6-10	0-9
7600.0 - 7999.9	6-11	0-9	6-11	0-9
8000.0 - 8499.9	6-11	0-9	6-11	0-9
8500.0 - 8999.9	6-11	0-8	6-11	0-8
9000.0 - 9499.9	7-11	0-8	7-11	0-8
9500.0 - 9999.9	8-12	0-8	8-12	0-8
10000.0 - 10499.9	8-12	0-8	8-12	0-8
10500.0 - 10999.9	9-12	0-8	9-12	0-8
11000.0 - 11499.9	9-12	0-8	9-12	0-8
11500.0 - 11999.9	9-12	0-7	9-12	0-7
12000.0 - 12499.9	10-13	0-7	10-13	0-7
12500.0 - 12999.9	10-13	0-7	10-13	0-7
13000.0 - 13499.9	10-13	0-7	10-13	0-7
13500.0 - 13999.9	10-13	0-7	10-13	0-7
14000.0 - 14499.9	10-13	0-7	10-13	0-7
14500.0 - 14999.9	10-13	0-7	10-13	0-7

SUPPLEMENT 5 T 1130

Table 2a continued

FREQUENCY BANDS IN T1130 kHz	AERIAL LENGTH			
	5-8 m		9-15 m	
	Reso- nance	Load	Reso- nance	Load
15000.0 - 15599.9	11-14	0-7	11-14	0-7
15500.0 - 15999.9	11-14	0-7	11-14	0-7
16000.0 - 16499.9	11-14	0-7	11-14	0-7
16500.0 - 16999.9	11-14	0-7	11-14	0-7
17000.0 - 17499.9	11-14	0-7	11-14	0-7
17500.0 - 17999.9	11-14	0-7	11-14	0-7
18000.0 - 18999.9	11-14	0-6	11-14	0-6
19000.0 - 19999.9	12-14	0-6	12-14	0-6
20000.0 - 20999.9	13-15	0-5	13-15	0-5
21000.0 - 21999.9	13-15	0-5	13-15	0-5
22000.0 - 22999.9	14-15	0-4	14-15	0-4
23000.0 - 23999.9	14-15	0-4	14-15	0-4
24000.0 - 24999.9	14-15	0-4	14-15	0-4
25000.0 - 25999.9	14-15	0-4	14-15	0-4
26000.0 - 26999.9	14-15	0-4	14-15	0-4
27000.0 - 27999.9	14-15	0-4	14-15	0-4
Fixed 2182	0-3	0-1	4-7	0-1

This table is based on several measurements, but it must only be considered as a guide.

To make the table more complete it is most important that you fill in the TUNING TABLE FOR T1135 in the back of this manual and return it to S. P. Radio.

If it is not possible to tune the transmitter within the resonance and load numbers listed in table 2, then use TABLE 2a.

AERIAL LENGTH T1135														
FREQUENCY BANDS in T1135 kHz	9 m		10 m		11 m		12 m		13 m		14 m		15 m	
	Reso- nance	Load	Reso- nance	Load	Reso- nance	Load	Reso- nance	Load	Reso- nance	Load	Reso- nance	Load	Reso- nance	Load
1600.0 - 1799.9	4-6	1	4-6	0-1	4-6	0-1	4-6	0-1	4-6	0	4-6	0	4-6	0
1800.0 - 1999.9	4-6	0-1	4-6	0	4-6	0	4-6	0	4-6	0	4-6	0	4-6	0
2000.0 - 2199.9	4-6	0	4-6	0	4-6	0	4-6	0	4-6	0	4-6	0	4-6	0
2200.0 - 2399.9	4-6	0	4-6	0	4-6	0	4-6	0	4-6	0	4-6	0	4-6	0
2400.0 - 2599.9	4-6	0	4-6	0	4-6	0	4-6	0	4-7	0	4-7	0	4-7	0
2600.0 - 2799.9	4-6	0	4-6	0	4-6	0	4-6	0	4-7	0-1	4-7	0-1	4-7	0-1
2800.0 - 2999.9	4-7	0	4-7	0	4-7	0	4-7	0	4-7	0-1	4-7	0-1	4-7	0-1
3000.0 - 3099.9	4-7	0	4-7	0	4-7	0	4-7	0	4-7	0-1	4-7	0-1	4-7	0-1
3100.0 - 3399.9	4-7	0	4-7	0	4-7	0	4-7	0	4-7	0-1	4-7	0-1	4-7	0-1
3400.0 - 3699.9	4-7	0	4-7	0-1	4-7	0-1	4-7	0-1	4-7	0-1	4-7	1-2	4-7	1-2
3700.0 - 3999.9	4-7	0-1	4-7	0-1	4-7	0-2	4-7	0-2	4-7	0-3	4-7	0-3	4-7	0-4
4000.0 - 4299.9	5-7	0-2	5-7	0-2	5-7	0-2	5-7	0-2	5-8	0-3	5-8	1-7	5-8	1-7
4300.0 - 4599.9	5-7	0-2	5-8	0-2	5-8	0-2	5-8	0-2	5-8	0-3	5-8	1-8	5-8	1-9
4600.0 - 4999.9	5-8	0-2	5-8	0-2	5-8	0-2	5-8	0-3	5-9	7-10	5-9	7-10	6-9	7-10
5000.0 - 5499.9	6-8	0-2	6-9	2-5	6-9	5-10	6-9	5-10	6-9	5-10	6-9	5-10	6-9	2-5
5500.0 - 5999.9	6-9	1-3	6-9	5-10	6-9	5-10	6-10	5-10	6-9	5-10	6-9	2-6	6-9	2-6
6000.0 - 6399.9	6-9	1-5	6-9	5-9	7-9	5-9	7-9	5-10	7-9	4-8	7-9	4-8	7-9	4-8
6400.0 - 6999.9	6-9	4-8	6-9	5-9	7-9	4-8	7-9	4-8	7-9	4-8	7-9	4-8	7-9	3-6
7000.0 - 7599.9	6-9	4-8	6-9	4-8	7-9	3-6	7-9	4-8	7-9	4-8	7-9	4-8	7-9	2-5
7600.0 - 7999.9	6-9	4-8	6-9	4-8	6-9	2-6	7-9	2-6	7-9	2-6	7-9	2-6	7-9	2-4
8000.0 - 8499.9	6-9	3-6	6-9	4-8	6-9	1-4	7-9	1-4	7-9	1-4	7-9	1-4	7-9	2-4
8500.0 - 8999.9	7-10	3-6	7-10	2-6	7-10	2-5	7-10	1-4	7-10	1-4	7-10	1-4	7-10	1-4
9000.0 - 9499.9	7-11	3-6	7-10	2-6	7-10	2-5	7-10	1-4	7-10	1-4	7-10	1-4	7-10	1-4
9500.0 - 9999.9	7-11	2-5	7-11	1-4	7-11	1-4	7-11	1-4	7-10	0-3	7-10	0-3	7-10	0-3
10000.0 - 10499.9	7-11	2-5	7-11	1-4	7-11	1-4	7-11	0-3	7-11	0-3	7-11	0-3	7-11	0-3
10500.0 - 10999.9	7-11	1-4	7-11	1-4	7-11	0-3	7-11	0-3	7-11	0-3	7-11	0-3	7-11	0-3

TABLE 2 continued

FREQUENCY BANDS in T1135 kHz	AERIAL LENGTH T1135													
	9 m		10 m		11 m		12 m		13 m		14 m		15 m	
	Reso- nance	Load	Reso- nance	Load	Reso- nance	Load	Reso- nance	Load	Reso- nance	Load	Reso- nance	Load	Reso- nance	Load
11000.0 - 11499.9	8-11	0-3	8-11	0-3	8-11	0-3	8-11	0-3	8-11	0-3	8-11	0-3	8-11	0-3
11500.0 - 11999.9	8-11	0-3	8-11	0-3	8-11	0-3	8-11	0-3	8-11	0-3	8-11	0-3	8-11	0-4
12000.0 - 12499.9	10-13	0-4	10-13	0-4	10-13	0-4	10-13	0-5	10-13	0-5	10-13	0-5	10-13	0-5
12500.0 - 12999.9	10-13	0-4	10-13	0-4	10-13	0-4	10-13	0-5	10-13	0-5	10-13	0-5	10-13	0-5
13000.0 - 13499.9	10-13	0-4	10-13	0-4	10-13	0-4	10-13	0-5	10-13	0-5	10-13	0-5	10-13	0-5
13500.0 - 13999.9	10-13	0-4	10-13	0-4	10-13	0-4	10-13	0-5	10-13	0-5	10-13	0-5	10-13	0-5
14000.0 - 14499.9	10-13	0-4	10-13	0-4	10-13	0-4	10-13	0-5	10-13	1-6	11-13	1-6	11-13	0-5
14500.0 - 14999.9	10-13	0-4	10-13	0-4	10-13	0-4	11-13	0-5	11-13	1-6	11-13	1-6	11-13	1-6
15000.0 - 15599.9	11-13	1-5	11-13	1-5	11-13	1-5	11-13	0-5	11-13	1-6	11-13	1-6	11-13	1-6
15600.0 - 15999.9	11-13	1-5	11-13	1-5	11-13	1-5	11-13	1-6	11-13	1-6	12-14	1-5	12-14	1-5
16000.0 - 16499.9	11-13	1-5	11-13	1-5	11-13	1-5	12-14	1-6	12-14	2-5	12-14	1-5	12-14	1-5
16500.0 - 16999.9	11-13	1-4	11-13	1-4	11-13	1-4	12-14	2-5	12-14	2-5	12-14	1-5	12-14	1-5
17000.0 - 17499.9	11-13	1-4	11-14	1-4	11-14	2-5	12-14	2-5	12-14	2-5	11-14	1-5	11-14	1-5
17500.0 - 17999.9	11-13	1-4	11-14	2-5	11-14	2-6	12-14	2-5	12-14	1-5	12-14	0-4	12-14	0-4
18000.0 - 18999.9	12-15	0-4	11-14	2-5	11-14	1-5	12-14	1-5	12-14	1-4	12-14	0-4	12-14	0-4
19000.0 - 19999.9	12-15	0-4	12-15	2-5	11-14	1-5	12-14	1-5	12-14	1-4	12-14	0-4	12-14	0-4
20000.0 - 20999.9	13-15	0-4	12-15	1-5	11-14	0-5	12-14	0-5	12-14	0-4	12-14	0-4	12-15	0-4
21000.0 - 21999.9	13-15	0-4	12-15	0-4	12-15	0-4	12-15	0-4	12-15	0-4	12-15	0-4	13-15	0-4
22000.0 - 22999.9	14-15	1-4	14-15	1-4	14-15	1-4	14-15	1-4	14-15	1-4	14-15	1-4	14-15	1-4
23000.0 - 23999.9	14-15	0-4	14-15	0-4	14-15	0-4	14-15	0-4	14-15	0-4	14-15	0-4	14-15	0-4
24000.0 - 24999.9	14-15	0-4	14-15	0-4	14-15	0-4	14-15	0-4	14-15	0-4	14-15	0-4	14-15	0-4
25000.0 - 25999.9	14-15	0-4	14-15	0-4	14-15	0-4	14-15	0-4	14-15	0-4	14-15	0-4	14-15	0-4
26000.0 - 26999.9	14-15	0-4	14-15	0-4	14-15	0-4	14-15	0-4	14-15	0-4	14-15	0-4	14-15	0-4
27000.0 - 27999.9	14-15	0-4	14-15	0-4	14-15	0-4	14-15	0-4	14-15	0-4	14-15	0-4	14-15	0-4
Fixed 2182	4-6	0	4-6	0	4-6	0	4-6	0	4-6	0	4-6	0	4-6	0

SUPPLEMENT 5 T 1135

TABLE 2a.

This table covers all permitted RESONANCE and LOAD numbers.

FREQUENCY BANDS IN T1135 kHz	AERIAL LENGTH 9-15 m	
	Reso- nance	Load
1600.0 - 1799.9	4-7	0-1
1800.0 - 1999.9	4-7	0-1
2000.0 - 2199.9	4-7	0-1
2200.0 - 2399.9	4-7	0-1
2400.0 - 2599.9	4-7	0-1
2600.0 - 2799.9	4-7	0-2
2800.0 - 2999.9	4-7	0-2
3000.0 - 3099.9	4-7	0-2
3100.0 - 3399.9	4-7	0-6
3400.0 - 3699.9	4-7	0-6
3700.0 - 3999.9	4-7	0-6
4000.0 - 4299.9	5-7	0-10
4300.0 - 4599.9	5-7	0-10
4600.0 - 4999.9	5-7	0-10
5000.0 - 5499.9	5-7	0-9
5500.0 - 5999.9	5-8	0-9
6000.0 - 6399.9	6-9	0-9
6400.0 - 6999.9	6-9	0-9
7000.0 - 7599.9	6-10	0-9
7600.0 - 7999.9	6-11	0-9
8000.0 - 8499.9	6-11	0-9
8500.0 - 8999.9	6-11	0-8
9000.0 - 9499.9	7-11	0-8
9500.0 - 9999.9	8-12	0-8
10000.0 - 10499.9	8-12	0-8
10500.0 - 10999.9	9-12	0-8
11000.0 - 11499.9	9-12	0-8
11500.0 - 11999.9	9-12	0-7
12000.0 - 12499.9	10-13	0-7
12500.0 - 12999.9	10-13	0-7
13000.0 - 13499.9	10-13	0-7
13500.0 - 13999.9	10-13	0-7
14000.0 - 14499.9	10-13	0-7
14500.0 - 14999.9	10-13	0-7

SUPPLEMENT 5 T1135

Table 2a continued

FREQUENCY BANDS IN T1135 kHz	AERIAL LENGTH 9-15 m	
	Reso- nance	Load
15000.0 - 15599.9	11-14	0-7
15500.0 - 15999.9	11-14	0-7
16000.0 - 16499.9	11-14	0-7
16500.0 - 16999.9	11-14	0-7
17000.0 - 17499.9	11-14	0-7
17500.0 - 17999.9	11-14	0-7
18000.0 - 18999.9	11-14	0-6
19000.0 - 19999.9	12-14	0-6
20000.0 - 20999.9	13-15	0-5
21000.0 - 21999.9	13-15	0-5
22000.0 - 22999.9	14-15	0-4
23000.0 - 23999.9	14-15	0-4
24000.0 - 24999.9	14-15	0-4
25000.0 - 25999.9	14-15	0-4
26000.0 - 26999.9	14-15	0-4
27000.0 - 27999.9	14-15	0-4
Fixed 2182	4-7	0-1

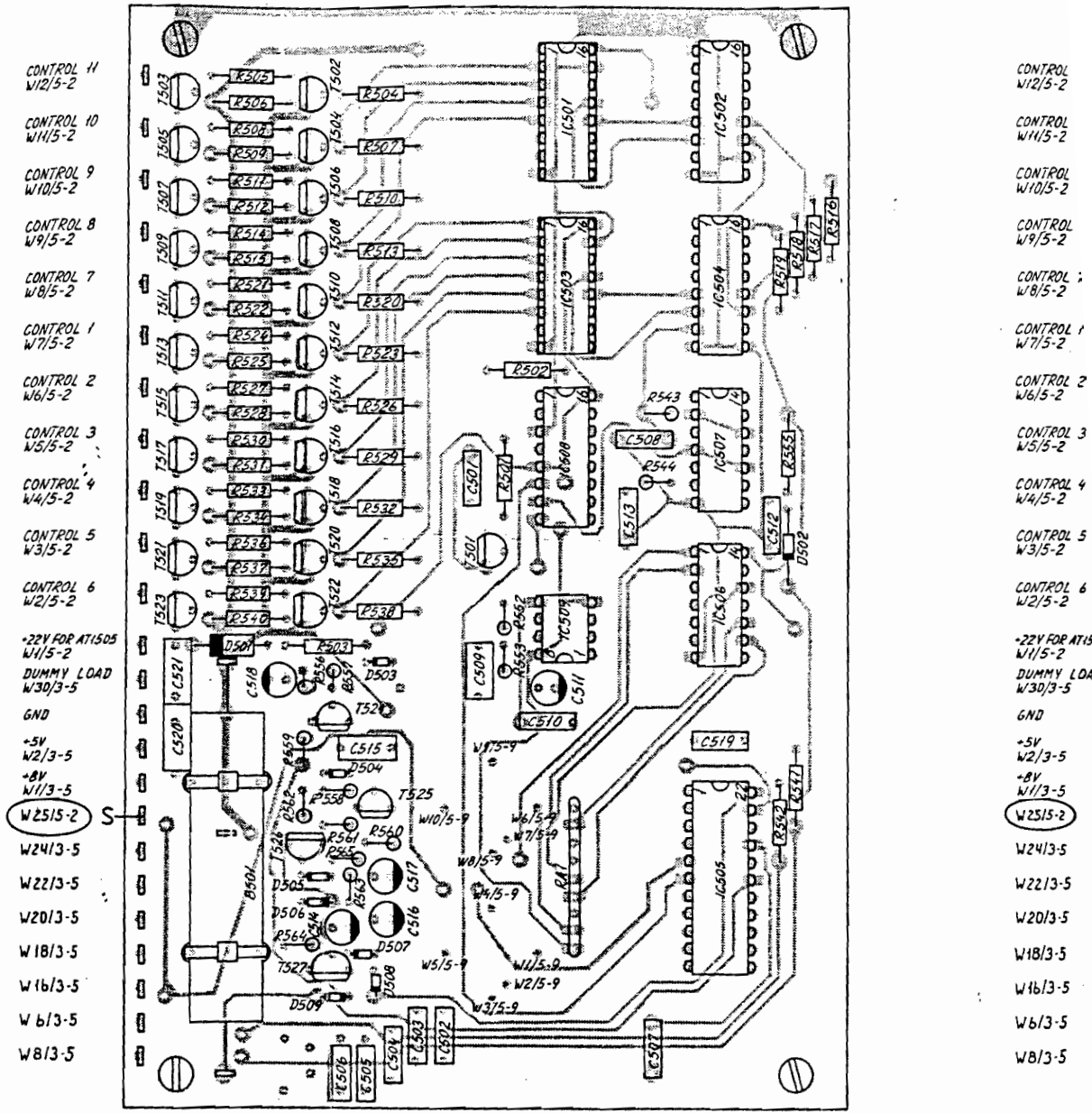

View from component side with upper side tracks.

TUNER CONTROL UNIT (MODULE 5/500)

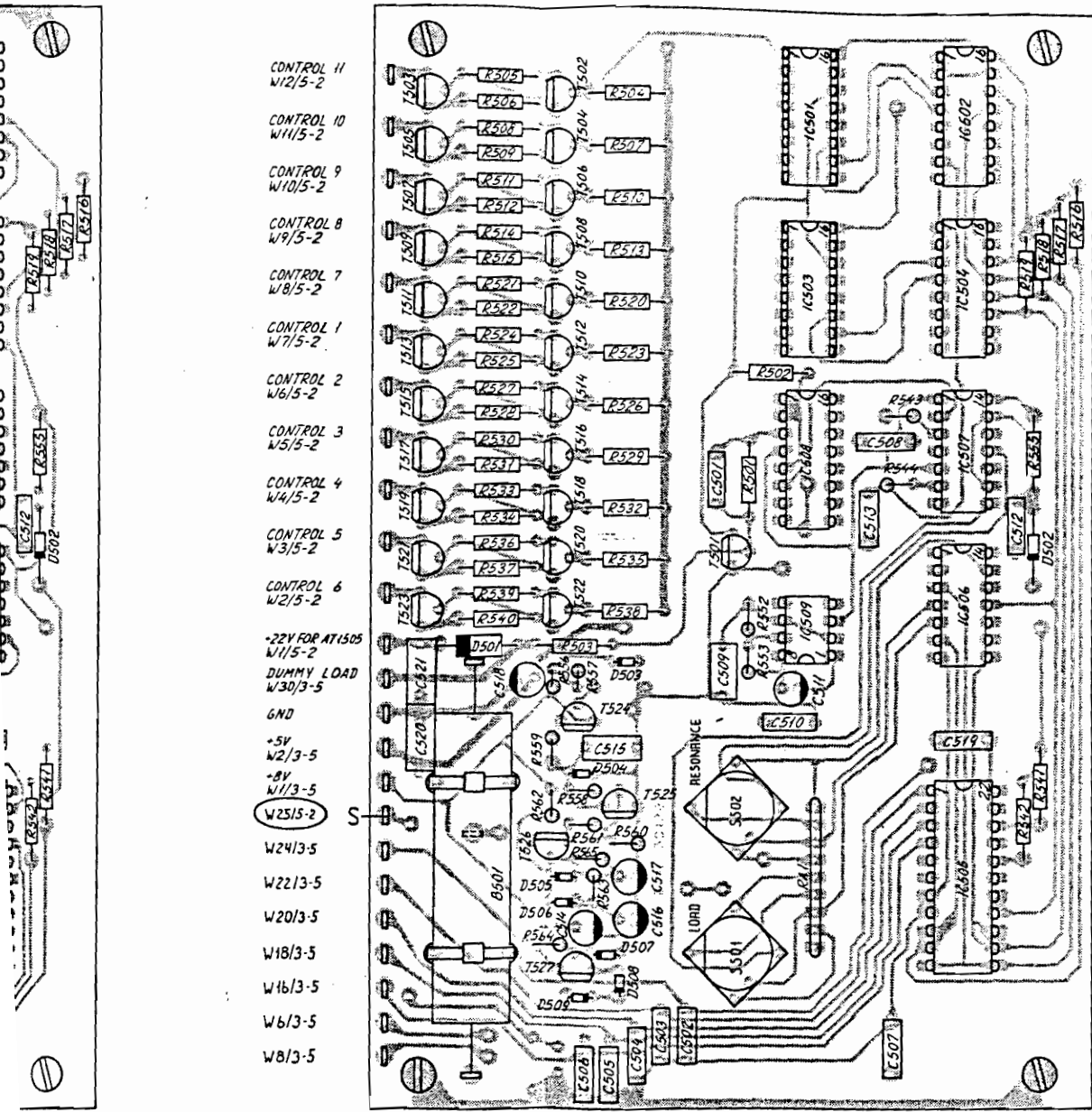

cks.

View from component side with lower side tracks.

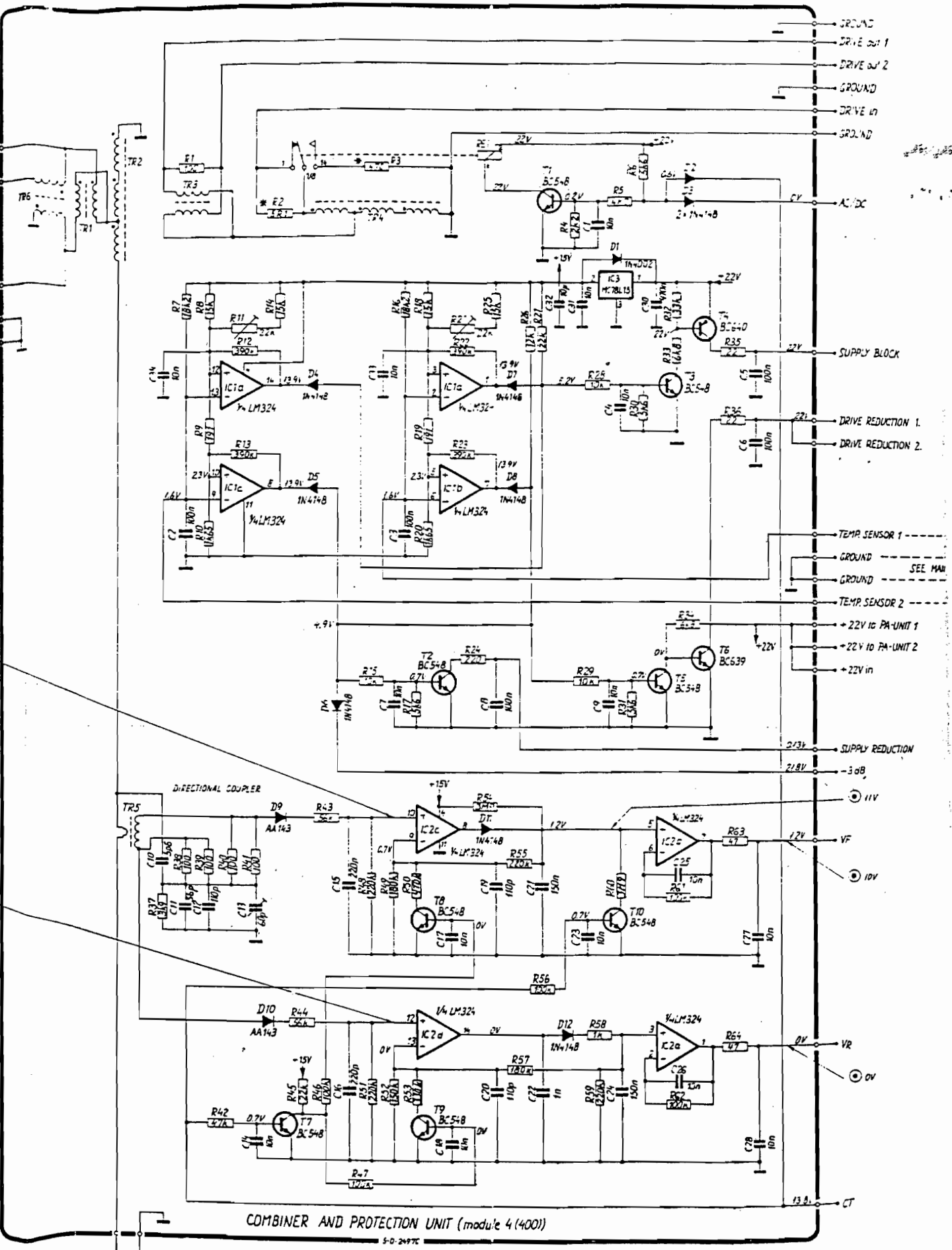

COMBINER AND PROTECTION UNIT (module 4/4001)

5-0-2497C

* Factory selected

Below serial no. 327896

- R50=220k
- R53=150k
- R54=2M7

(D)

GROUND DRIVE OUT 1
 GROUND DRIVE OUT 2
 GROUND DRIVE IN .75
 AC/DC W476-4
 SUPPLY BLANK W276-4
 DRIVE REDUCTION 1 W174-12
 DRIVE REDUCTION 2 W274-12
 TEMP SENSOR 1 W374-12
 TEMP SENSOR 2 W674-12
 +22V W774-12
 +27V W874-12
 +27V W376-4
 SUPPLY REDUCTION W176-4
 3.0A W576-4
 VF W413-4
 PA W093-4
 CT W974-3

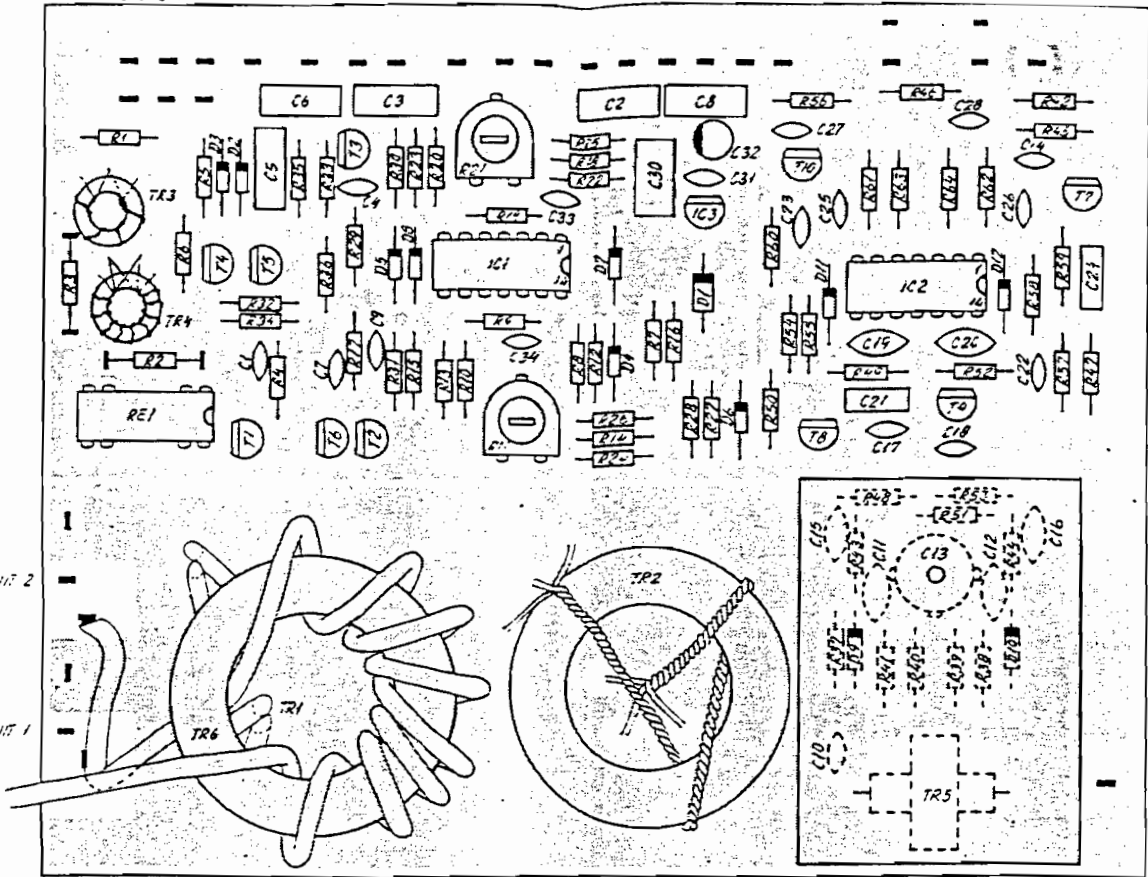

View from component side with upper side tracks.

GROUND DRIVE OUT 1
 GROUND DRIVE OUT 2
 GROUND DRIVE IN .75
 AC/DC W476-4
 SUPPLY BLANK W276-4
 DRIVE REDUCTION 1 W174-12
 DRIVE REDUCTION 2 W274-12
 TEMP SENSOR 1 W374-12
 TEMP SENSOR 2 W674-12
 +22V W774-12
 +27V W874-12
 +27V W376-4
 SUPPLY REDUCTION W176-4
 3.0A W576-4
 VF W413-4
 PA W093-4
 CT W974-3

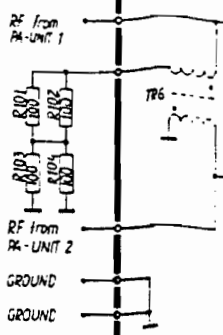
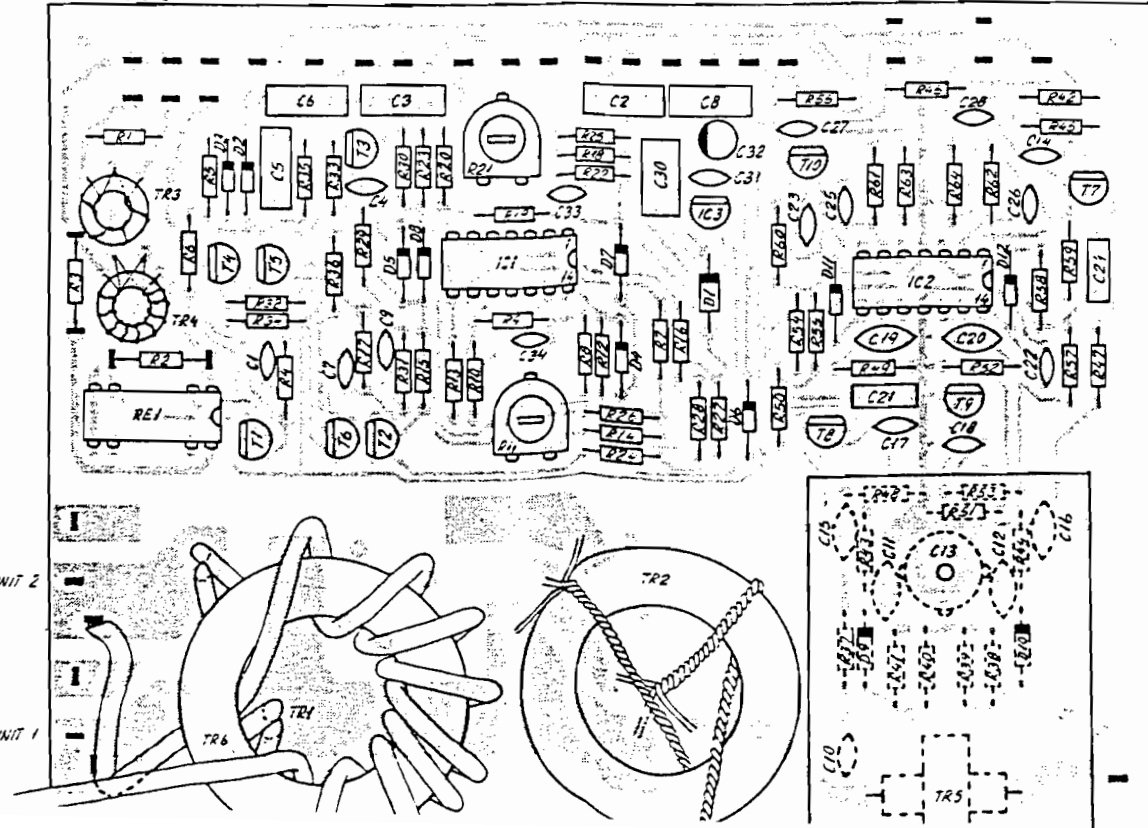

3V

0V

RF-OUT

RF-OUT

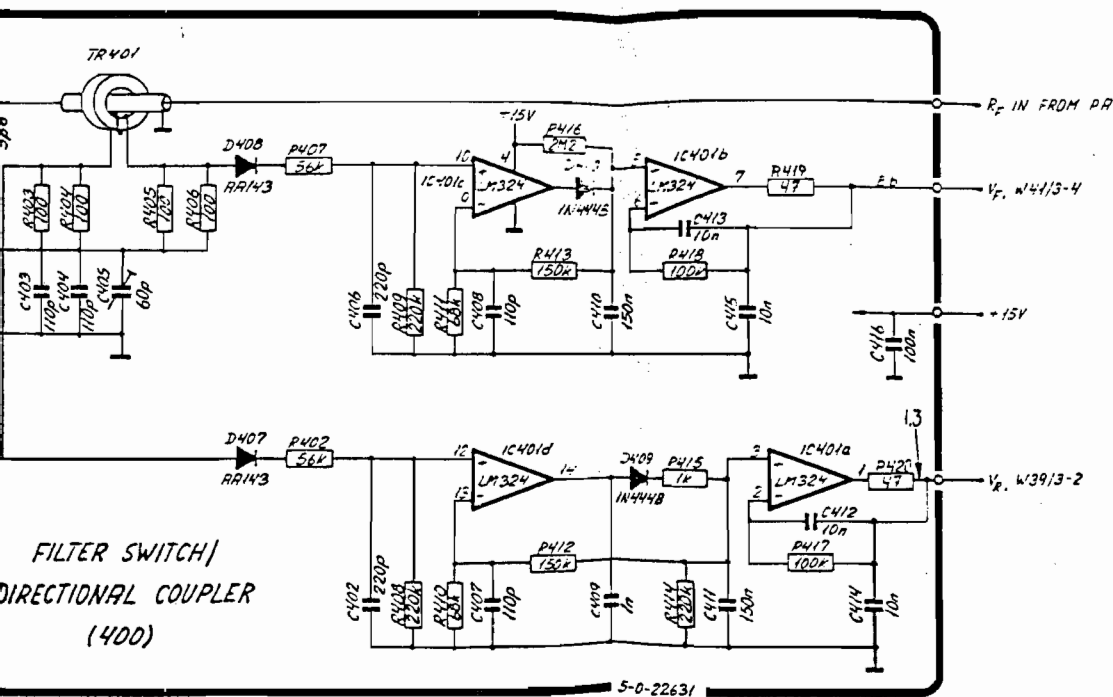

Below serial nr. 333280

R410 = 100k

R411 = 100k

R416 = 2M7

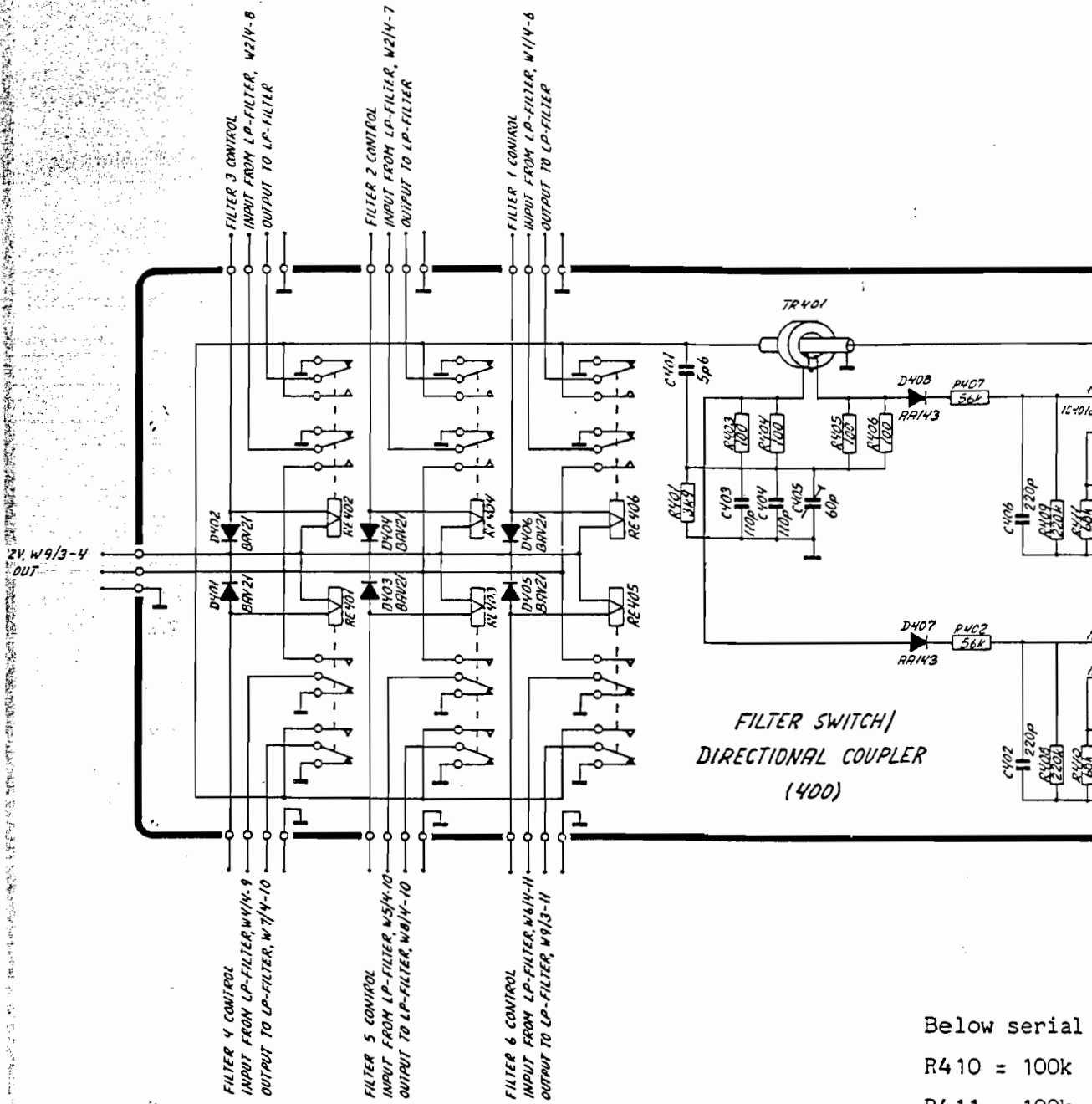

Below serial
 R410 = 100k
 R411 = 100k
 R416 = 2M7

5-0-23244

INPUT FILTER (200)

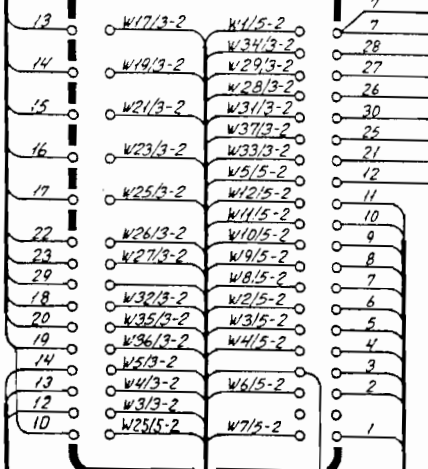

JACK D TO H1235

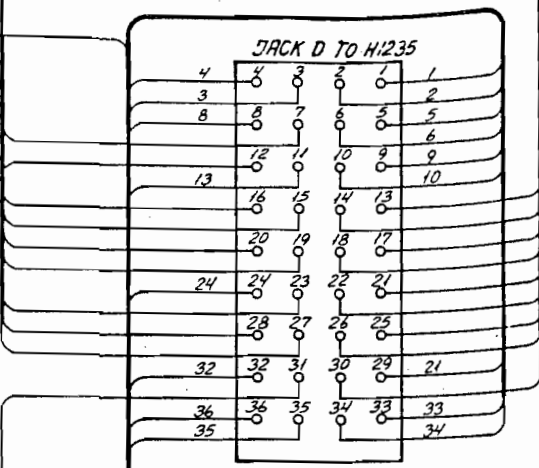

- 1 +22V TO Rx
- 2 +8V TO Rx
- 3 -45V TO Rx
- 4 +22V TO Ex
- 5 +8V TO Ex
- 6 -45V TO Ex
- 7 +22V FOR RT1500
- 8 Rx ON
- 9 GROUND TO Rx
- 10 \$
- 11 GROUND
- 12 CONTROL 3 IN
- 13 T
- 14 V
- 15 X
- 16 Y
- 17 Z
- 18 TUNE

PLUG E TO H1235

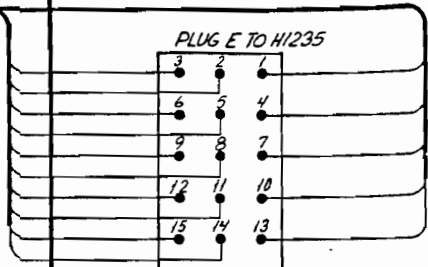

PLUG E

- 1 TUNER CONTROL 1
- 2 TUNER CONTROL 2
- 3 TUNER CONTROL 3
- 4 TUNER CONTROL 4
- 5 TUNER CONTROL 5
- 6 TUNER CONTROL 6
- 7 TUNER CONTROL 7
- 8 TUNER CONTROL 8
- 9 TUNER CONTROL 9
- 10 TUNER CONTROL 10
- 11 TUNER CONTROL 11
- 12 INVALID TUNING/180°
- 13 MOTOR/REAR CURRENT
- 14 REAR CURRENT

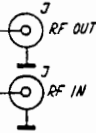

P101

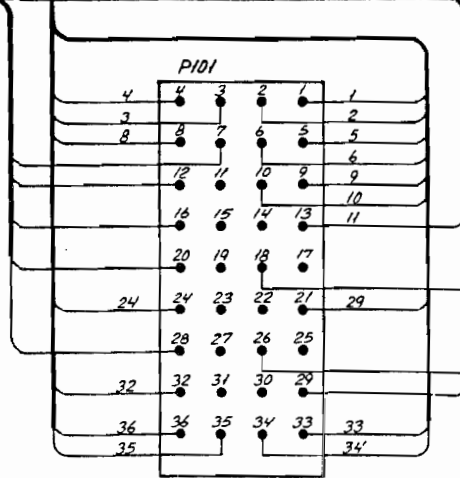

- 1 +22V TO Rx
- 2 +8V TO Rx
- 3 -45V TO Rx
- 4 +22V TO Ex
- 5 +8V TO Ex
- 6 -45V TO Ex
- 7 +22V FOR RT1500
- 8 Rx ON
- 9 GROUND TO Rx
- 10 GROUND TO Ex
- 11
- 12 POWER DOWN FROM PO1
- 13 GROUND
- 14
- 15
- 16 -45V TO TH30
- 17
- 18 BLOWER

P102

- 1 +22V
- 2 SUPPLY BLOCK
- 3 SUPPLY REDUCTION

P.A. - UNIT (1200)

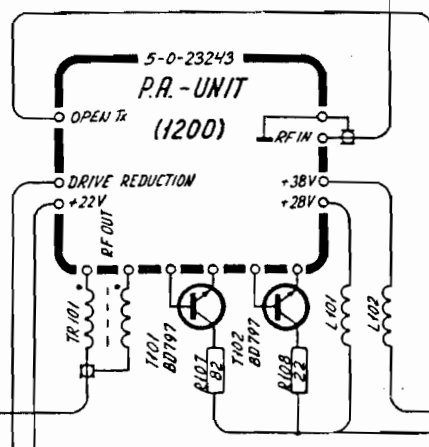

TEMPERATURE PROTECTION UNIT (1300)

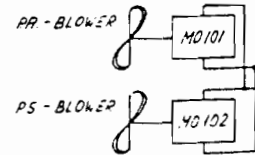

W14-11

TO POWER SUPPLY

MOUNTED ON ONE OF THE OUTPUT TRANSISTORS

TO POWER SUPPLY

TRANSMITTER CONTROL UNIT (300)

5-0-23108

INVALID TUNING / 180°
W3/3-2

REARIAL CURRENT
W5/3-2

MOTOR/REARIAL
CURRENT
W4/3-2

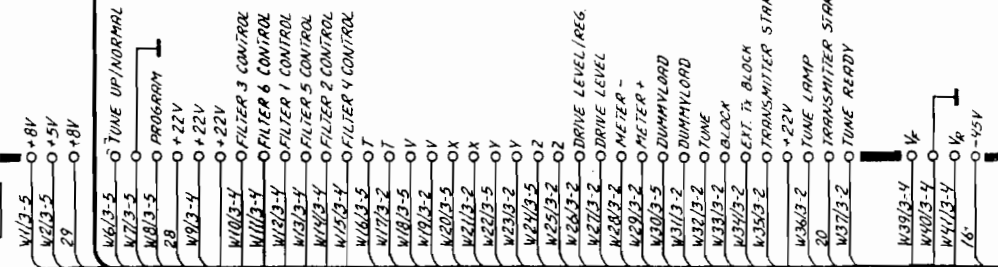
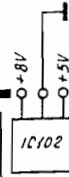
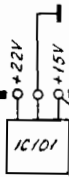

DIRECTIONAL COUPLER (400)

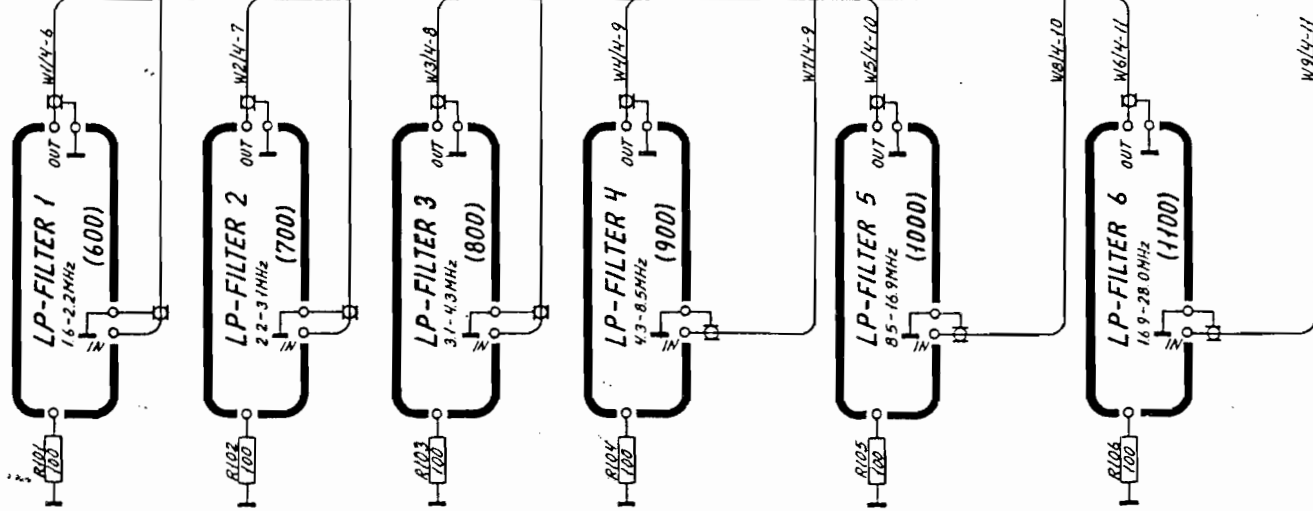
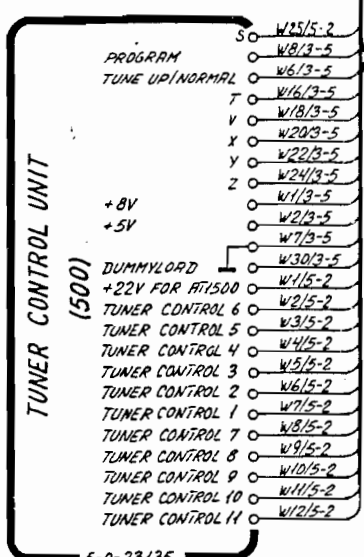
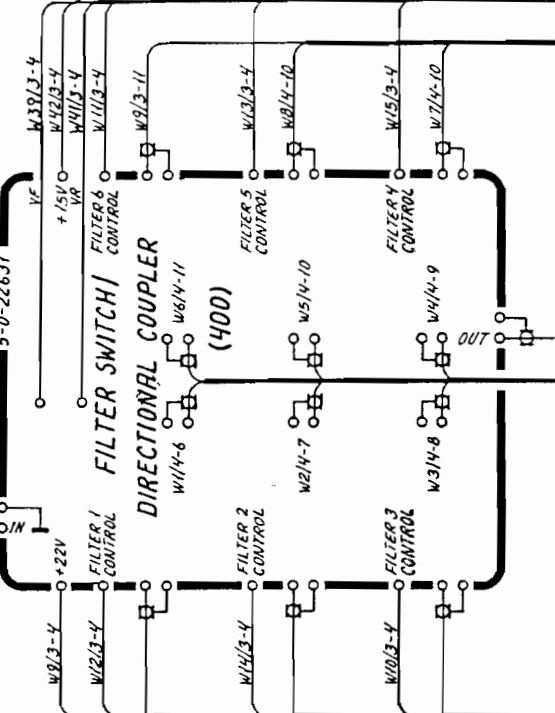

- 13
- 14
- 15
- 16
- 17
- 22
- 23
- 29
- 18
- 20
- 19
- 14
- 13
- 12
- 10

5-0-23135

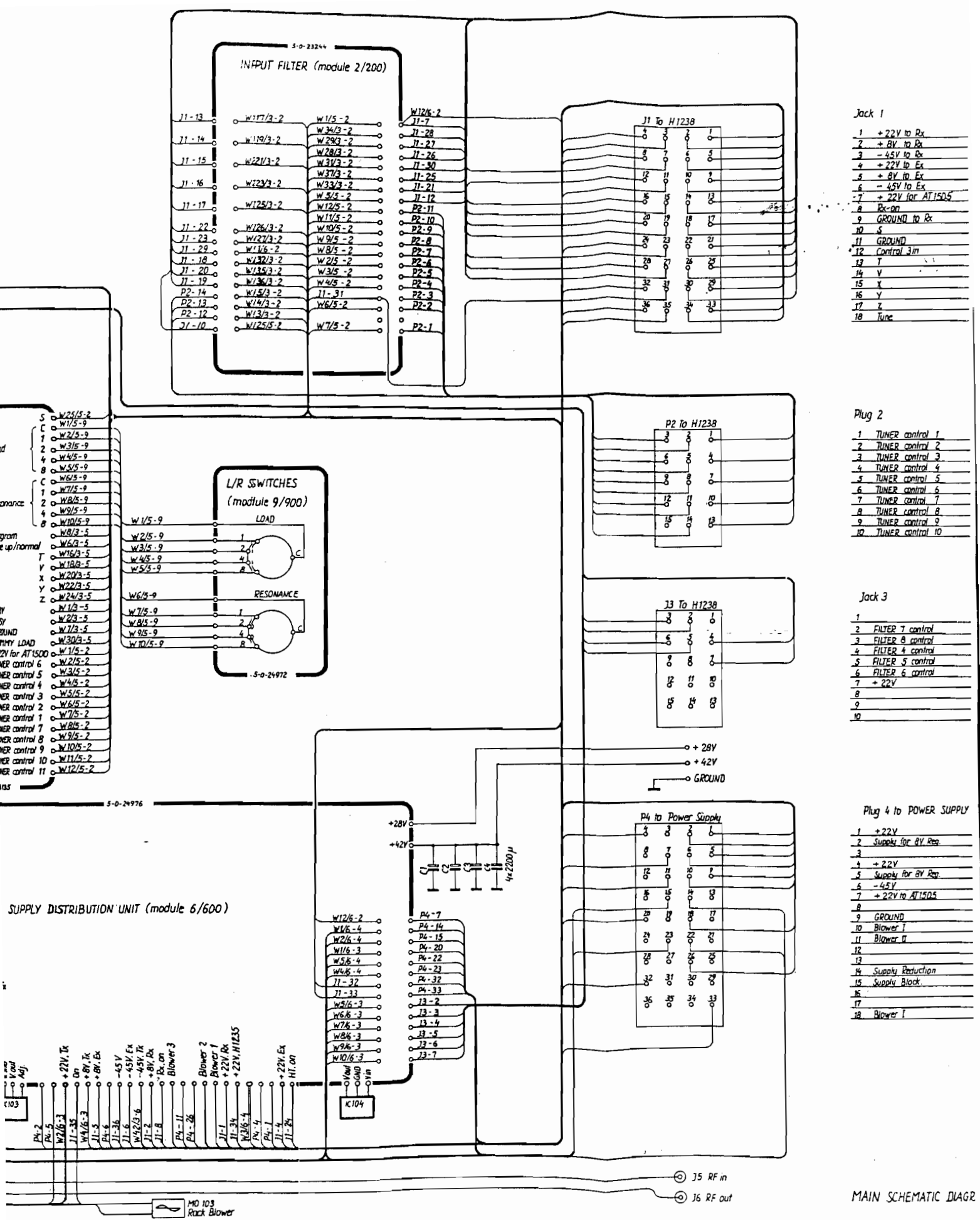

- Jack 1
- 1 +22V to Rx
 - 2 +8V to Rx
 - 3 -45V to Rx
 - 4 +22V to Ex
 - 5 +8V to Ex
 - 6 -45V to Ex
 - 7 +22V for AT1505
 - 8 Rx-on
 - 9 GROUND to Rx
 - 10 S
 - 11 GROUND
 - 12 Control 3m
 - 13 T
 - 14 V
 - 15 X
 - 16 Y
 - 17 Z
 - 18 Tune

- Plug 2
- 1 TUNER control 1
 - 2 TUNER control 2
 - 3 TUNER control 3
 - 4 TUNER control 4
 - 5 TUNER control 5
 - 6 TUNER control 6
 - 7 TUNER control 7
 - 8 TUNER control 8
 - 9 TUNER control 9
 - 10 TUNER control 10

- Jack 3
- 1
 - 2 FILTER 7 control
 - 3 FILTER 8 control
 - 4 FILTER 4 control
 - 5 FILTER 5 control
 - 6 FILTER 6 control
 - 7 +22V
 - 8
 - 9
 - 10

- Plug 4 to POWER SUPPLY
- 1 +22V
 - 2 Supply for 8V Reg
 - 3
 - 4 +22V
 - 5 Supply for 8V Reg
 - 6 -45V
 - 7 +22V to AT1505
 - 8
 - 9 GROUND
 - 10 Blower I
 - 11 Blower II
 - 12
 - 13
 - 14 Supply Reduction
 - 15 Supply Block
 - 16
 - 17
 - 18 Blower I

MAIN SCHEMATIC DIAGR

MAIN SCHEI

TRANSMITTER CONTROL UNIT (module 3/300)

5-0-23108

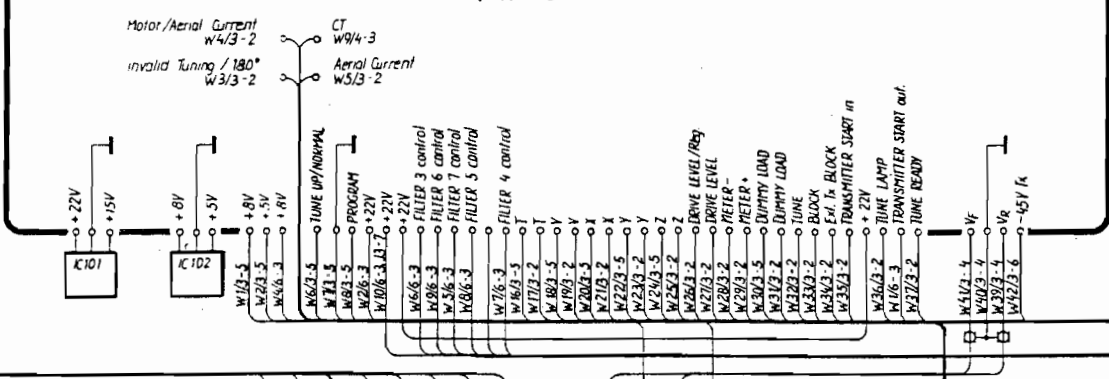

COMBINER and PROTECTION UNIT (module 4/400)

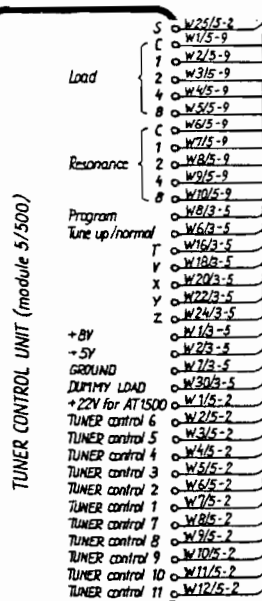
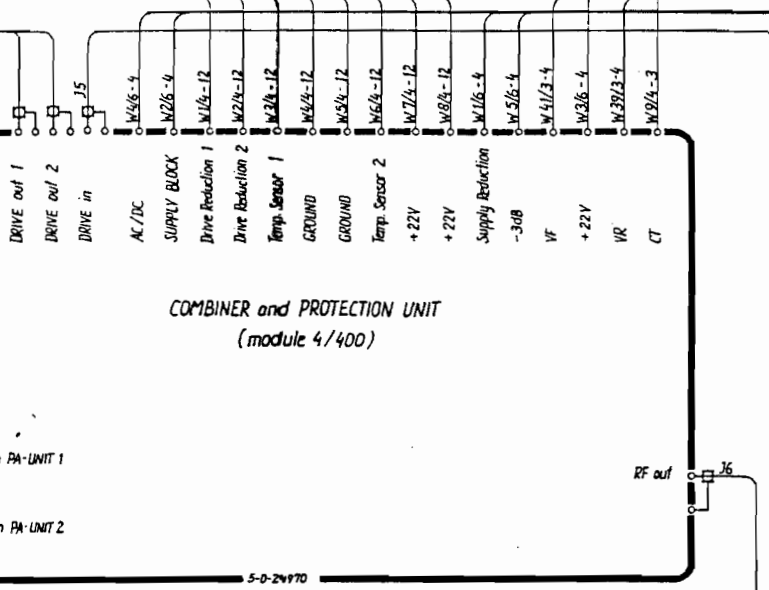

PA-UNIT 1 (module 12/1200)

PA-UNIT 2 (module 12/1200)

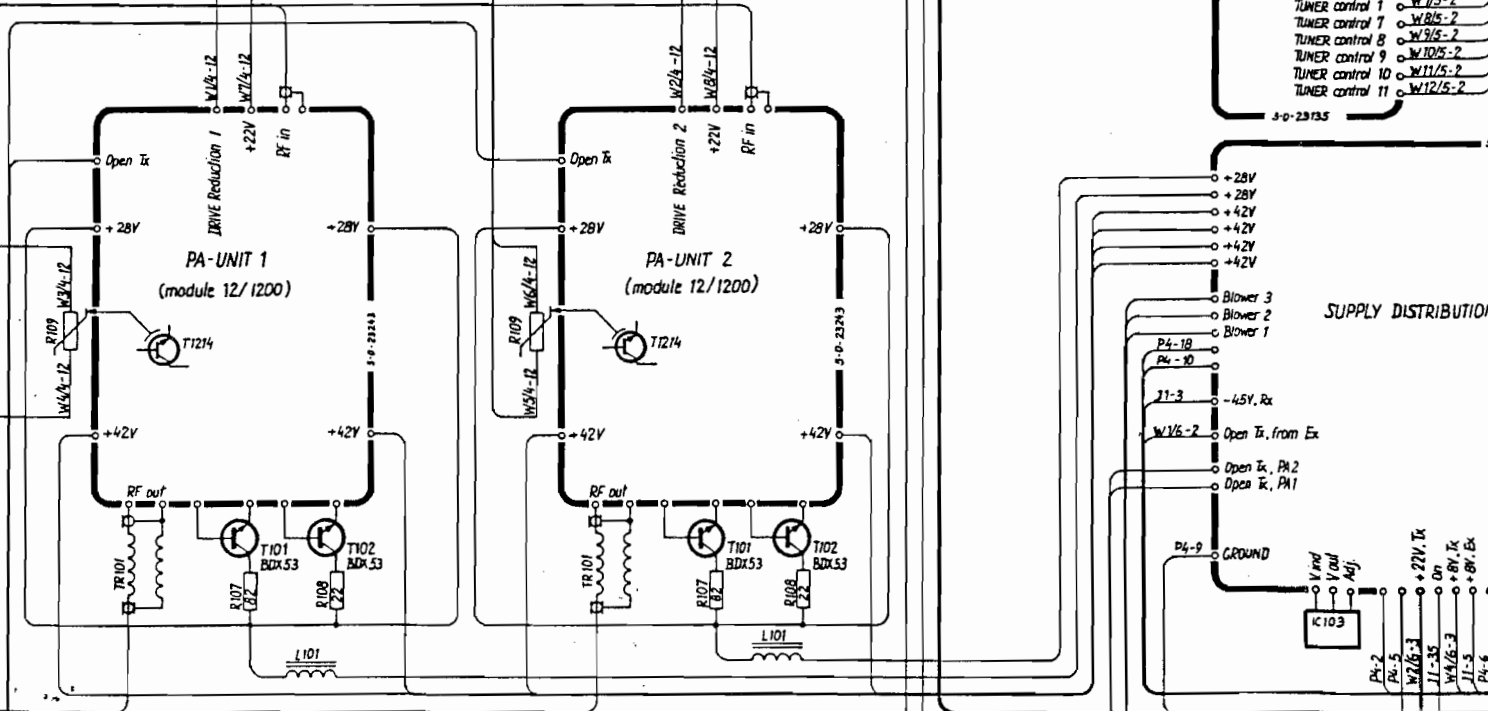

SUPPLY DISTRIBUTION UNIT

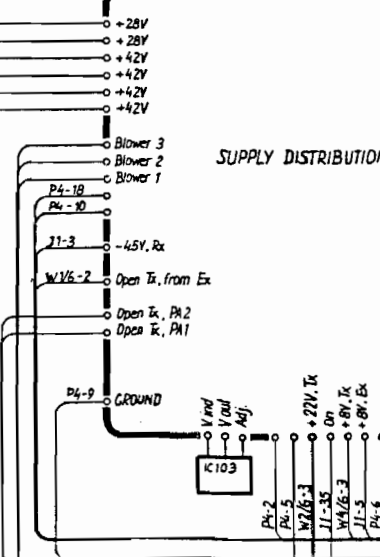

PA1 M0101 Blower

PA2 M0102 Blower

5-0-23135

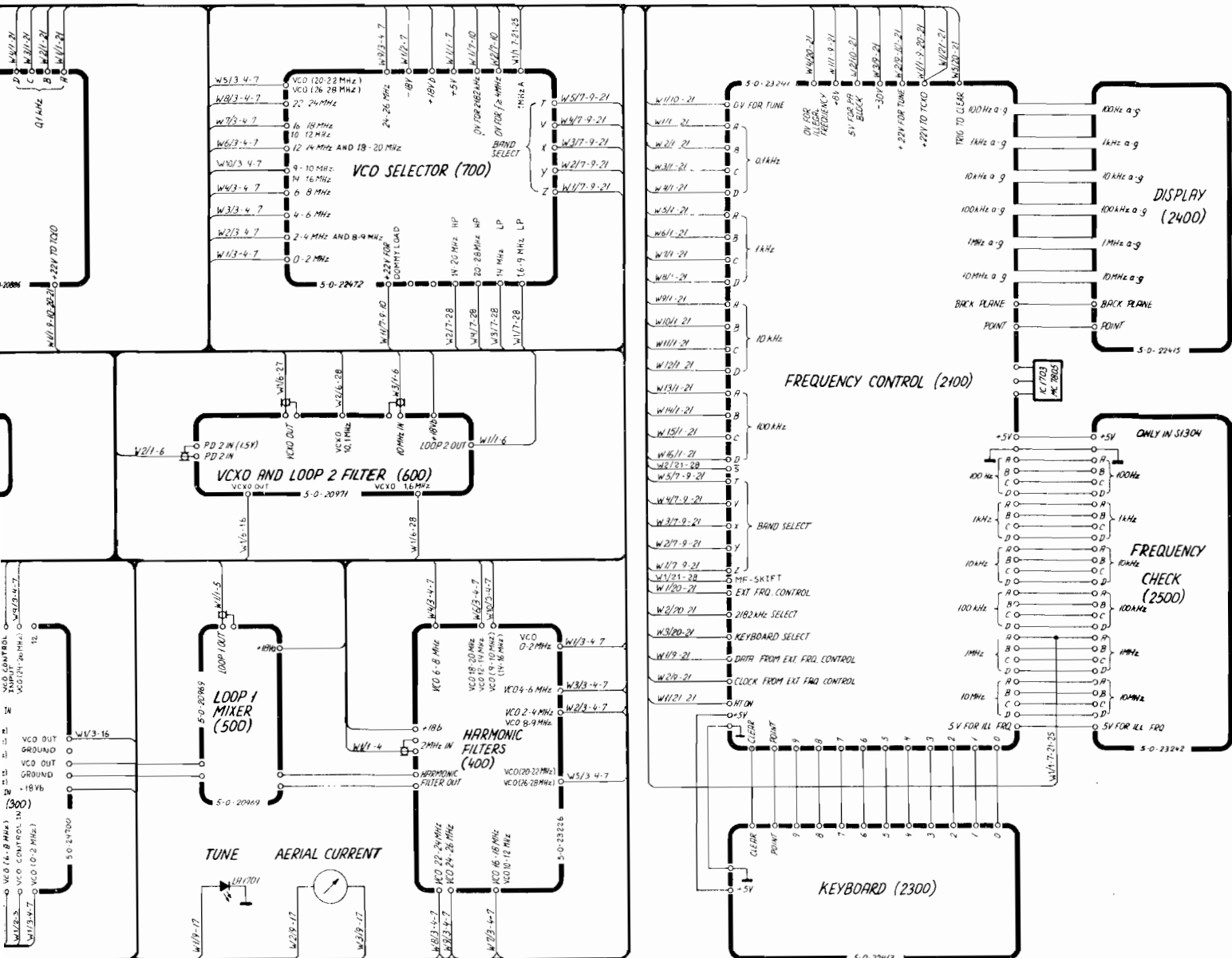

- | | | |
|-------------------------|----------------------|-------------------------------|
| FROM MICROPHONE | 13 T | 25 CLOCK FROM EXT FRQ CONTROL |
| MORSE RELAY | 14 V | 26 AERIAL METER 1 |
| KEY BLOCK | 15 X | 27 AERIAL METER 2 |
| 22V | 16 Y | 28 AF TO MICROTELEPHONE |
| RF | 17 Z | 29 OPEN TX |
| 5V | 18 22V FOR TUNE | 30 22V FOR DUMMY LOAD |
| C FROM TELEX | 19 TO TUNE LAMP | 31 GROUND FOR MIC AND TELEX |
| F FROM TELEX | 20 TRANSMITTER START | 32 + 22V SIMPLEX |
| V FROM KEY | 21 PH BLOCK | 33 AF TO LOUDSPEAKER |
| POW? | 22 DRIVE LEVEL 1 | 34 HANDSET KEY |
| RF FROM EXT FRQ CONTROL | 23 DRIVE LEVEL 2 | 35 S BIT |
| F FROM RX | 24 HT DN | 36 + 22V TO TCXO |

MAIN SCHEMATIC DIAGRAM
FOR
SAILOR EXCITER S1303/S1304
WITH OPTION I

5-0-23223

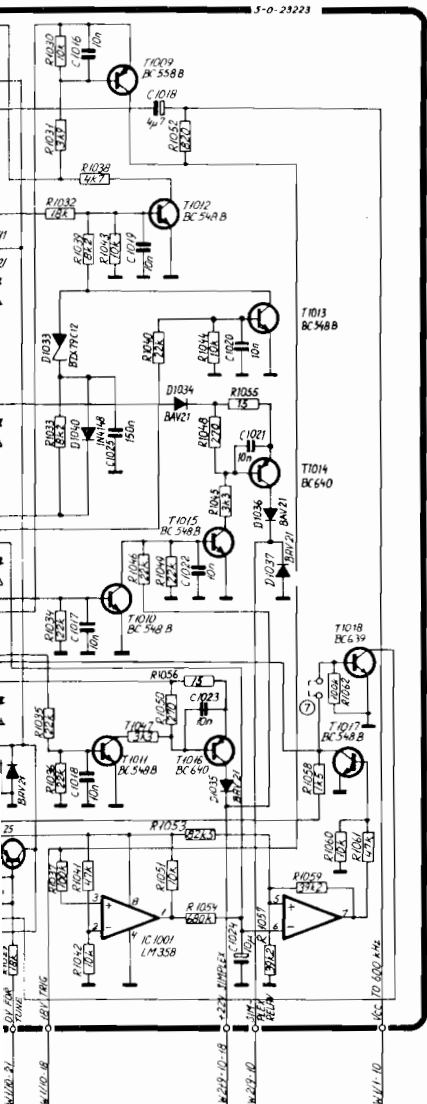

2182 kHz FIXED

MODE SELECTED	DIODE MOUNTED
R3H	D1002, D1004
R3J	D1007
VIA MODE SWITCH	D1009

- ① ALARM SIGNAL IS SEND IN R3J
- ② ALARM SIGNAL IS SEND IN R3H
- ③ R3A } CAN NOT BE SEND ABOVE 4MHz
- ④ R3H }
- ⑤ R3A } CAN NOT BE SEND
- ⑥ R3H }
- ⑦ INSERT THE STRAPS 7 AND 8 TO PREVENT CONTINUOUS CARRIER IN MARITEX MODE.
- ⑧

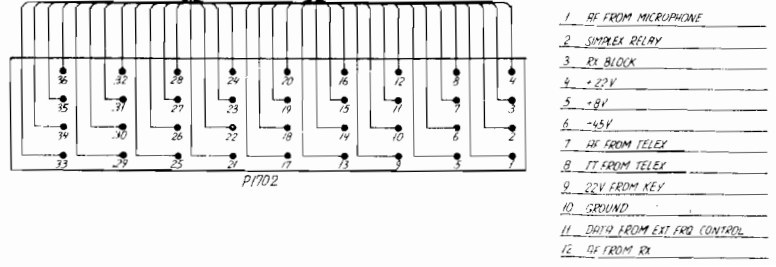
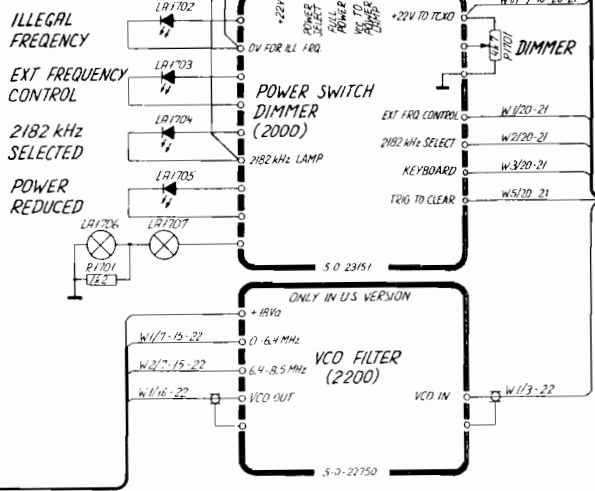
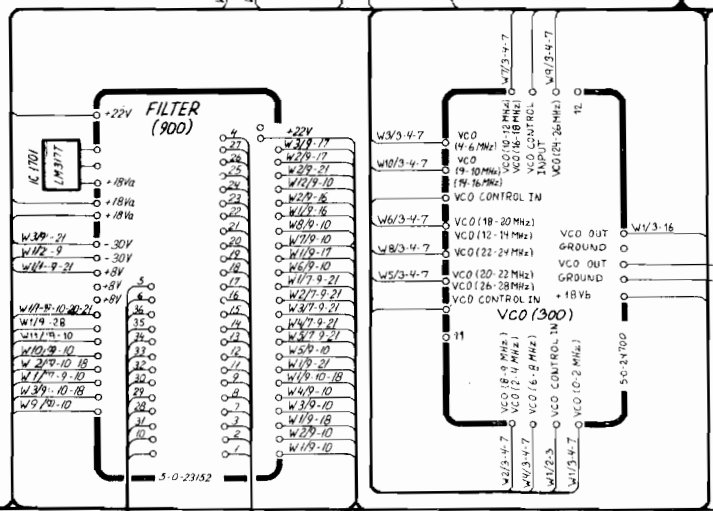
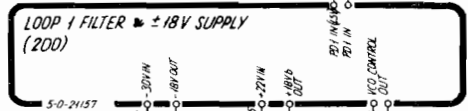
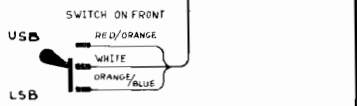
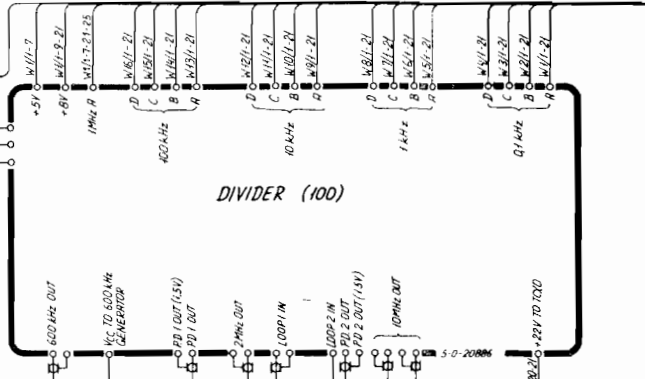
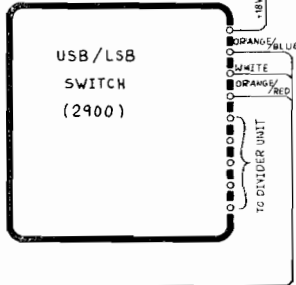

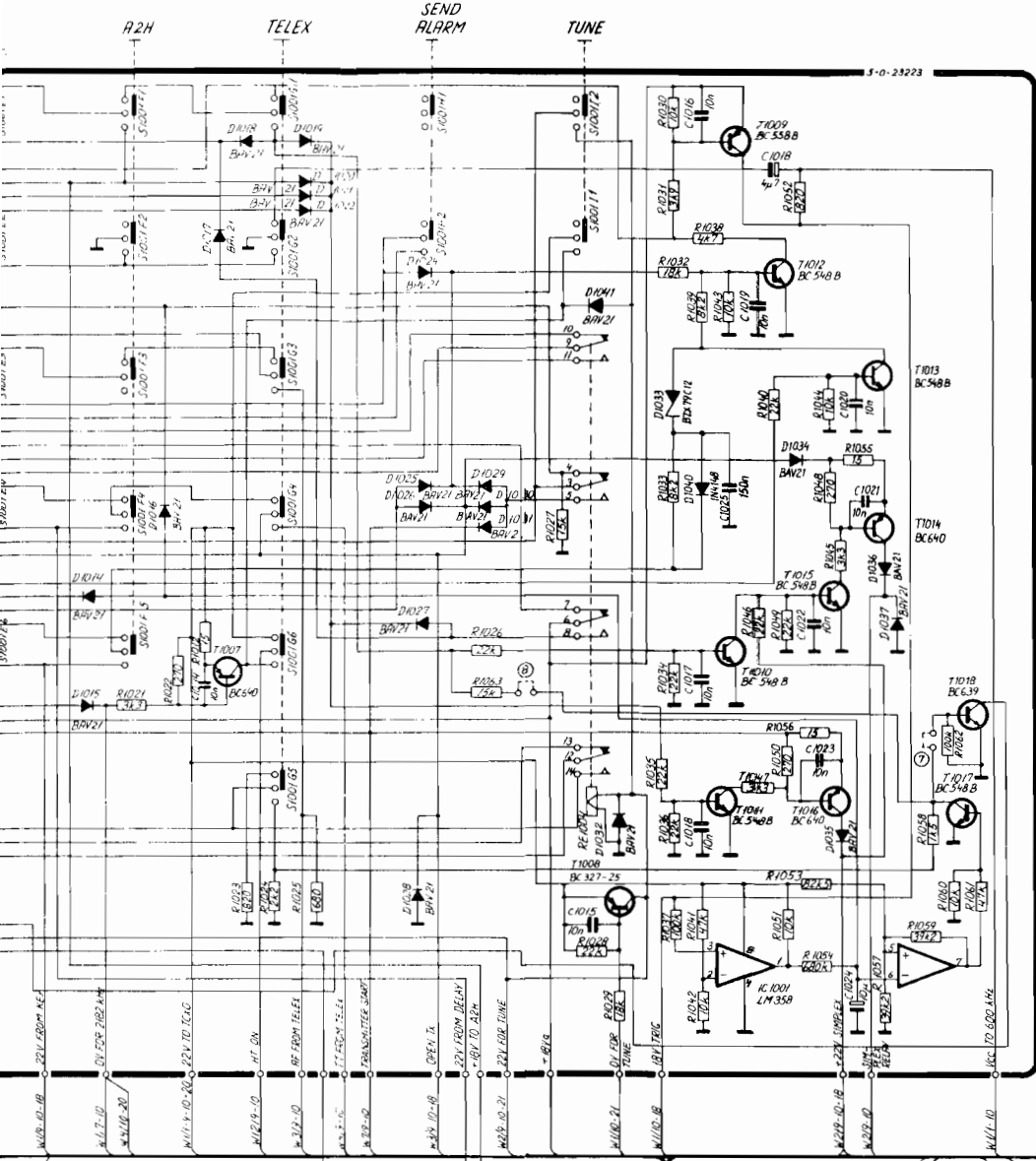

2182 kHz FIXED

MODE SELECTED	DIODE MOUNTED
A3H	D1002, D1004
A3J	D1007
VIA MODE SWITCH	D1009

- ① ALARM SIGNAL IS SEND IN A3J
- ② ALARM SIGNAL IS SEND IN A3H
- ③ A3J CAN NOT BE SEND ABOVE 4MHz
- ④ A3H
- ⑤ A3J CAN NOT BE SEND
- ⑥ A3H
- ⑦ INSERT THE STRAPS 7 AND 8 TO PREVENT CONTINUOUS CARRIER IN MARTEX MODE.

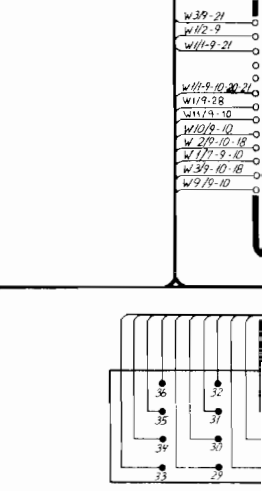
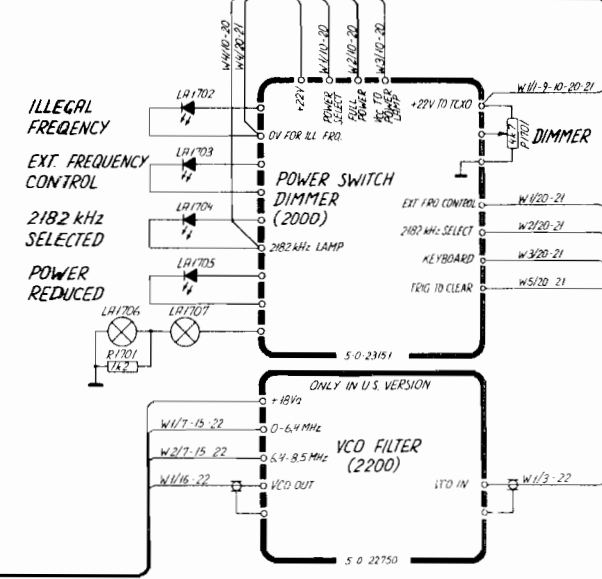
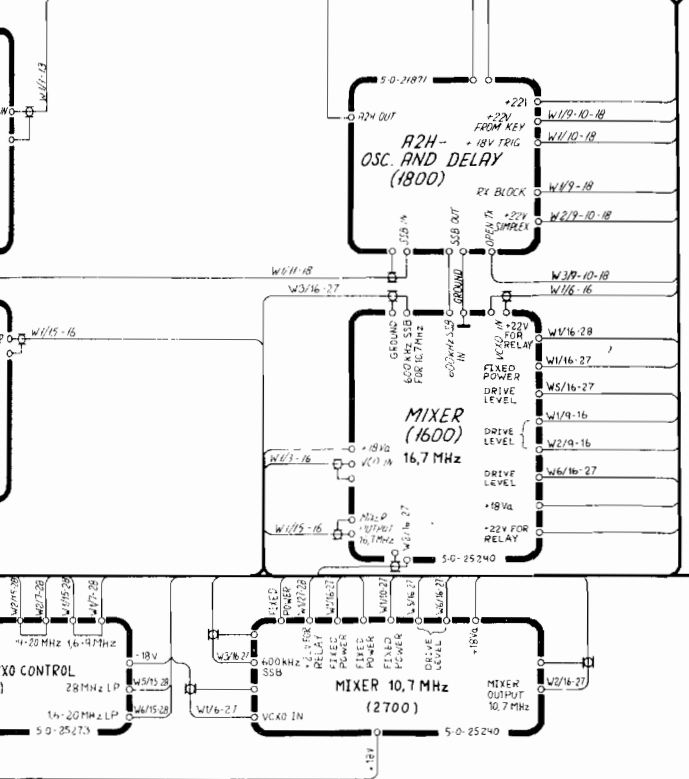
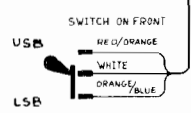
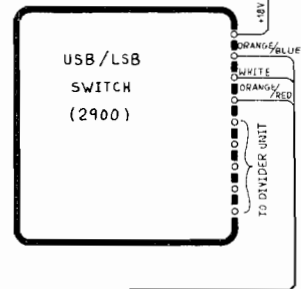

S1303/4-I
4-0-25396

