

Impedance Characteristics of Some Experimental Broad-Band Antennas for Vertical Incidence Ionosphere Sounding

By H. N. Cones

This paper presents the results of measurements of the modulus of input impedance of a number of nonresonant antennas over a continuous frequency range from 1 to 25 megacycles per second. These antennas were constructed as part of a design problem of developing an effective radiating system for vertical-incidence ionospheric sounding equipment. The data are in the form of curves, and the antennas are compared with each other from the standpoint of uniformity of impedance over the frequency range. The use of multiple-wire construction to lower the average input impedance, to minimize impedance variations, and to increase radiation efficiency is discussed.

I. General

The delta antenna (illustrated in figs. 2 and 4) has a number of characteristics that make it attractive as an antenna for vertical-incidence ionospheric work. It is fairly compact, requires only a single large mast, and is easy to erect. However, its input impedance, even when properly terminated, may vary from as low as 300 ohms to as much as 1,200 or 1,400 ohms over the frequency range of 1 to 25 Mc/s, and the use of a transmission line to feed the antenna causes an even greater impedance variation. Furthermore, the radiation efficiency at the lower frequencies of the operating range is quite small.

The vertical rhombic antenna, which is another form of nonresonant antenna frequently used for ionospheric measurements, is somewhat more difficult to construct than the delta, requiring one large mast and two smaller ones. Theoretical considerations lead to the conclusion that the impedance characteristics of a vertical rhombic antenna should be somewhat more uniform than that of a delta. However, the tests performed thus far were limited to existing rhombic antennas that were not designed for optimum impedance characteristics. Theoretical considerations would also lead one to believe that the radiating efficiency of a vertical rhombic antenna, which is small com-

pared to the wavelength used, would be lower than a delta or vee antenna designed for the same frequency range.

Elementary considerations indicate that the radiated field of a nonresonant antenna would be proportional to the product of the current flowing through the antenna and the length of the antenna, and is some function of the configuration of the antenna. Because physical limitations restrict the height and, therefore, the length of the antenna, the most promising approach to a more efficient radiator is a multiple wire antenna. Effectively, this lowers the impedance of the antenna, permitting increased current for a given input power. A qualitative analysis indicates that increased radiation efficiency may be thus obtained. Furthermore, because a multiple-wire antenna permits adjustment of wire spacing along its length, it appears to offer a possibility of also securing a more uniform impedance characteristic over the entire frequency range.

The remainder of this report describes the techniques and results of experimental impedance measurements of the following types of antennas:

1. Single-wire delta antennas.
2. A series of multiple-wire delta antennas.
3. A vertical *W* antenna.
4. A vertical double-*W* antenna.

II. Instrumentation

For measurement of antenna impedance, a balanced recording impedance meter developed at this Bureau was used. A description of this instrument was presented at the winter 1946-47 IRE convention in New York City.¹ Figure 1 presents the block diagrams of the instrument.

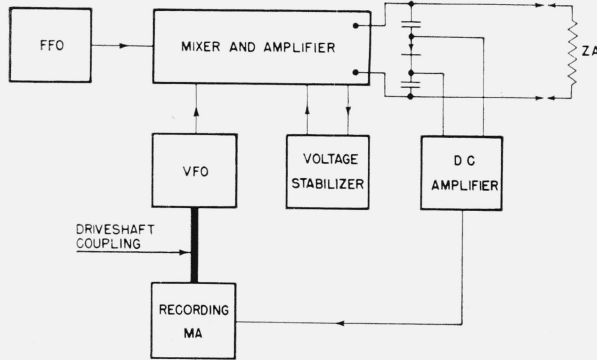

FIGURE 1. Block diagram of impedance meter.

Briefly, it consists of a 57-Mc/s fixed-frequency oscillator heating with a variable frequency oscillator covering the frequency band from 57 to 82 Mc/s. The difference frequency of 0 to 25 Mc/s is passed through a wide-band amplifier designed to have a constant current output. The output voltage is therefore directly proportional to the absolute magnitude of impedance connected across the output terminals; no direct indication of the phase angle of the impedance has thus far been provided. This voltage is rectified, amplified, and applied to a recording milliammeter. The recording milliammeter and the variable frequency oscillator are mechanically coupled, so that the impedance is plotted as a function of frequency. A voltage stabilizer is incorporated to insure constant output current. The instrument is calibrated by substituting non-inductive resistors for the unknown impedance.

III. Results of Measurements

Figure 2 shows the construction of a simple form of single-wire delta antenna. The principle of a delta antenna is similar to that of a terminated vertical vee in the higher portion of its frequency range; at lower frequencies it behaves somewhat

¹ H. V. Cottony, A method of rapid continuous measurement of antenna impedance over a wide frequency range. Paper presented before IRE Convention, March 6, 1947, New York, N. Y.

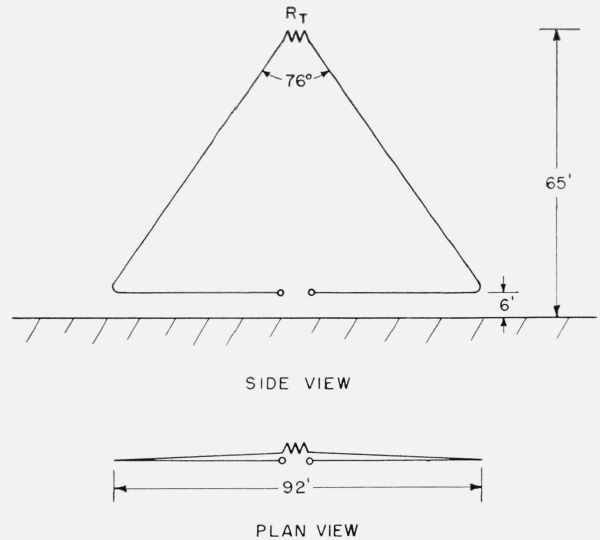

FIGURE 2. Construction of single-wire delta antenna.

like a loop. The delta construction minimizes the number of supports required and serves to solve the problem of termination. Measurements of the impedance of the antenna shown in figure 2 were made for values of terminating resistance, R_T , equal to 800, 1,000, 1,200, 1,400, and 1,600 ohms. Figure 3 shows the impedance of the antenna over the frequency range of 1 through 25 Mc/s, using a terminating resistance of 1,000 ohms, which was found to be optimum for minimum variation of input impedance. The range of input impedance in this case was from 300 to 1,200 ohms. The value of R_T was not particularly critical, since the range of input impedance for the 800-ohm termination was 300 to 1,300 ohms, and for the 1,600-ohm termination was 300 to 1,200 ohms. The impedance at frequencies from 16 to 25 Mc/s was only slightly affected by changes in terminating resistance. At frequencies below 8 Mc/s, the impedance characteristics were influenced to a

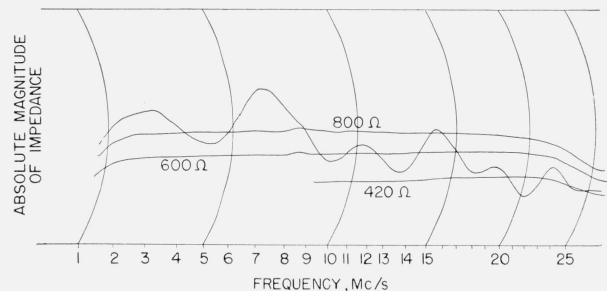

FIGURE 3. Impedance of single-wire delta antenna for optimum termination of 1,000 ohms.

much greater degree by different values of terminating resistance, the number and location of the peaks being changed, although the maximum and minimum values of impedance remained about the same.

Figure 4 shows the construction of a variation of the delta antenna designed by J. W. Cox of the Great Baddow Research Laboratories of the British Marconi Co. It is distinguished from the simpler delta by the presence of corkscrew turns at the lower corners of the antenna. These turns are intended to improve the performance of the antenna. Figure 5 shows the impedance characteristics of this antenna. It can be seen that with optimum terminating resistor (R_T equal to 1,200 ohms), the impedance varied from less than 400 ohms to approximately 1,100 ohms, and it appears that the impedance characteristics of the antenna were not appreciably improved by the addition of the corkscrew turns.

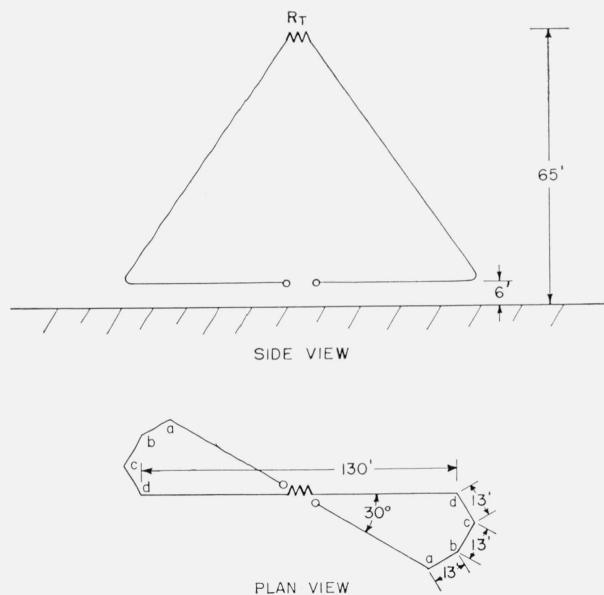

FIGURE 4. Construction of modified delta antenna.

Point a, 6 ft. above ground; point b, 8 ft. above ground; point c, 10 ft. above ground; point d, 14 ft. above ground.

The first multiple-wire delta constructed was identical in size shape to the antenna shown in figure 2, except that it was constructed by using two parallel wires spaced 15 in. apart in place of the single wire. Measurements were made by using a number of different terminations. Figure 6 shows the impedance characteristics of this antenna for an optimum termination of 600 ohms.

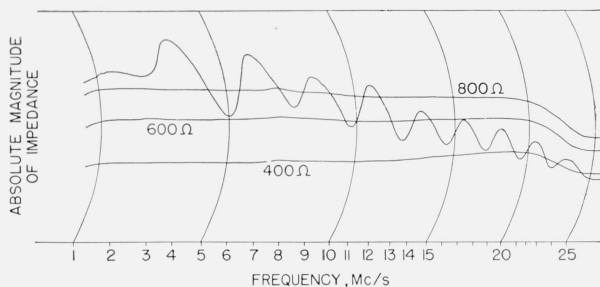

FIGURE 5. Impedance of modified delta antenna for optimum termination of 1,200 ohms.

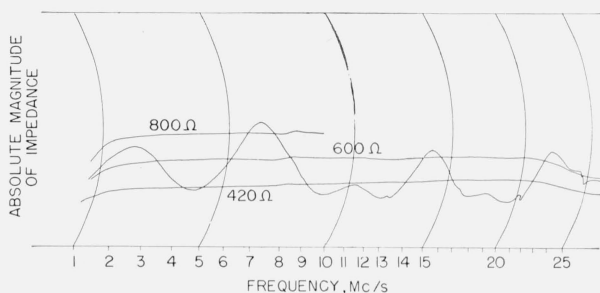

FIGURE 6. Impedance of parallel-wire delta antenna.

Construction identical to that of figure 2, except that two parallel wires spaced 15 in. apart are used. $R_T=600$ ohms.

The impedance in this case varied from 300 to 850 ohms. It should be noted that the parallel-wire delta terminated with 600 ohms was superior from the standpoint of uniformity of impedance to the single-wire delta terminated with 1,000 ohms. The impedance is lower and the variation small enough so that it would be practical to use a 600-ohm line to feed it.

Several other types of multiple-wire deltas were constructed. The best results were obtained when the oblique wires had the configuration shown in figure 7. Each leg consisted of two wires joined at the apex and the lower corners and flayed 36 in. apart at a point 18 ft. from the lower corner. The exact position of the spreaders is not critical nor is the plane of the wires. The horizontal wires, however, have a very significant effect on the impedance characteristics of the antenna. Tests were, therefore, made in which the arrangement of oblique wires shown in figure 7 remained unchanged and with the various arrangements of horizontal wires shown in the same figure. Referring to figure 8, curve A shows the impedance when only a single No. 12 wire was used on each side. Curve B shows the results obtained by replacing the single wire by two No. 18 wires spaced

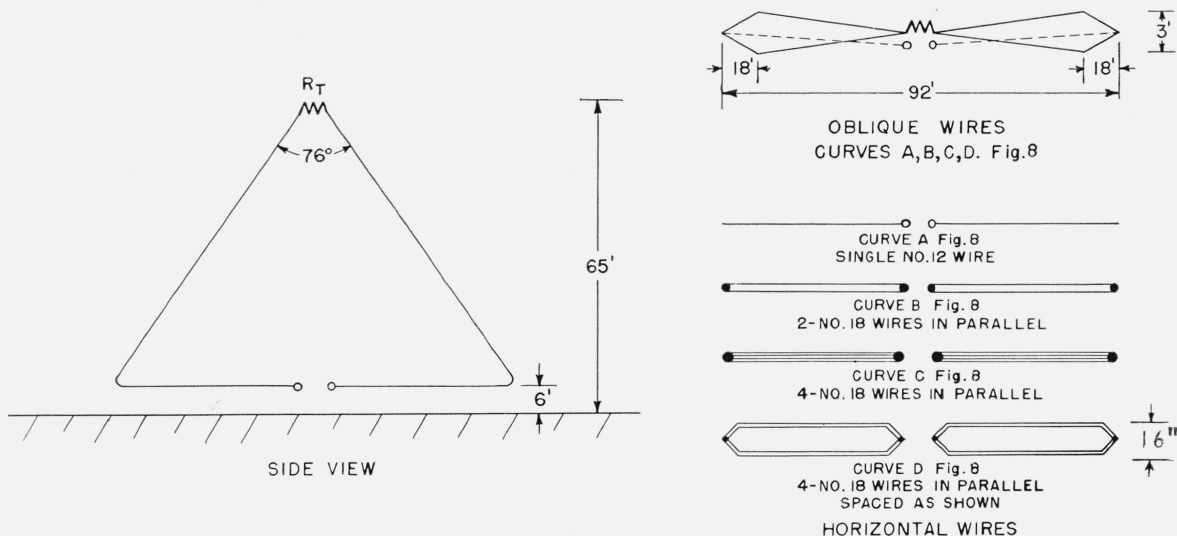

FIGURE 7. Configuration of oblique and horizontal wires of multiple-wire delta antennas.

Impedance curves shown in figure 8.

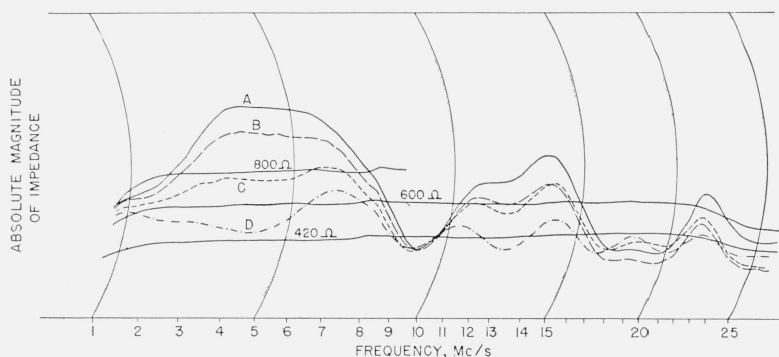

FIGURE 8. Impedance of multiple-wire delta antennas.

Each antenna terminated with 800-ohm resistor. Constructional details are shown in figure 7.

0.3 in. apart and connected in parallel. Curve C shows the results when four No. 18 wires were connected in parallel, and curve D the results when the bottom wires consisted of two pairs of No. 18 wires connected in parallel and spaced 16 in. between pairs, as shown in figure 7.

Figure 9 shows that the high-frequency impedance characteristics can be improved at the expense of the low-frequency characteristic by changing the terminating resistance from 800 to 600 ohms.

The *W* antenna, the construction of which is shown in figure 10, is essentially two vertical-vee antennas excited in phase. One side of each vee terminates in a common resistor, R_T , and the other sides are grounded by means of vertical wires connected to ground by another resistor

equal to one-half the value of R_T . The vees are fed by 800-ohm lines, which join to form a 400-ohm line. The impedance characteristic of the transmission-line system with the 800-ohm lines

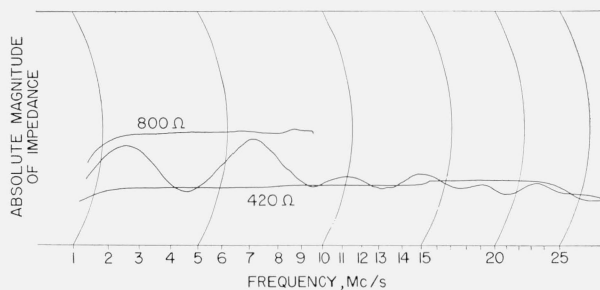

FIGURE 9. Impedance of multiple-wire delta antenna.

Same as curve D, figure 8, except that value of terminating resistor is 600 ohms.

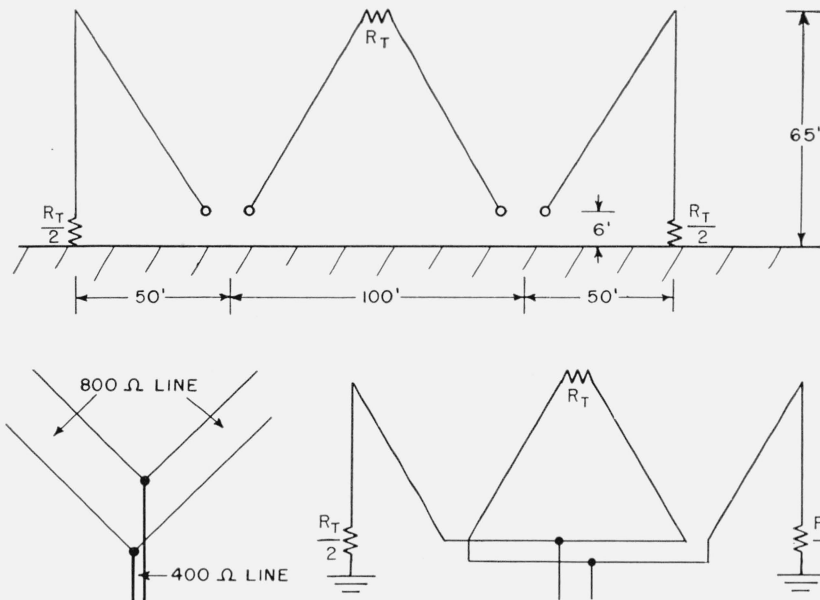

FIGURE 10. Construction of *W* antenna and associated transmission line system.

being terminated by 800-ohm resistors is shown in figure 11. Impedance measurements of the antenna were made for values of R_T equal to 600, 800, 1,000, 1,200, and 1,400 ohms. Figure 12 shows the impedance characteristics of this antenna with the optimum termination of 1,000 ohms between the two vee antennas and with 500 ohms on each side. For R_T equal to 600 ohms, the impedance variation was between 200 and 800 ohms over the entire range. Over most of the range, however, the impedance variation was only about 2:1. For R_T equal to 1,400 ohms, the impedance variation is only slightly greater than for the 1,000-ohm termination.

Another section of the *W* antenna was constructed to make a double-*W* antenna (four vertical vees all excited in phase). This antenna system is shown in figure 13. Each vee was fed with an 800-ohm line, pairs of 800-ohm lines being paralleled and fed with 400-ohm lines. The two resulting 400-ohm lines also were fed in parallel. The impedance looking into the transmission-line system was, therefore, 200 ohms. Since 200 ohms is not a suitable load for current designs of multi-frequency ionosphere recorders, it was necessary to introduce an impedance transformer. The design of an rf transformer aperiodic over a frequency range of 1 to 25 Mc and capable of handling

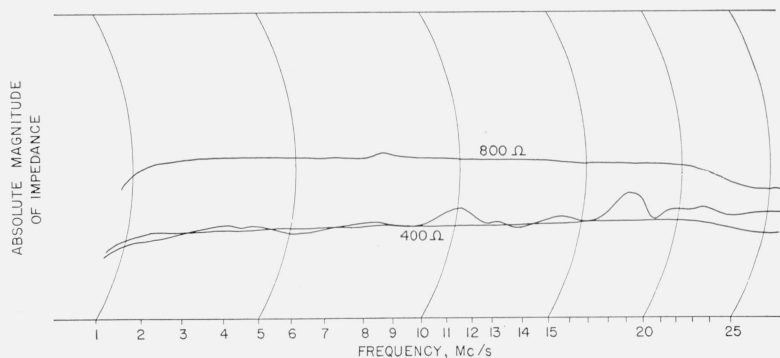

FIGURE 11. Impedance of transmission line system used with *W* antenna.

800-ohm lines terminated with 800-ohm resistors.

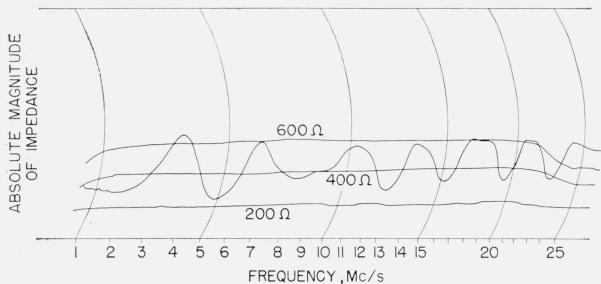

FIGURE 12. Impedance of *W* antenna for optimum termination of 1,000 ohms.

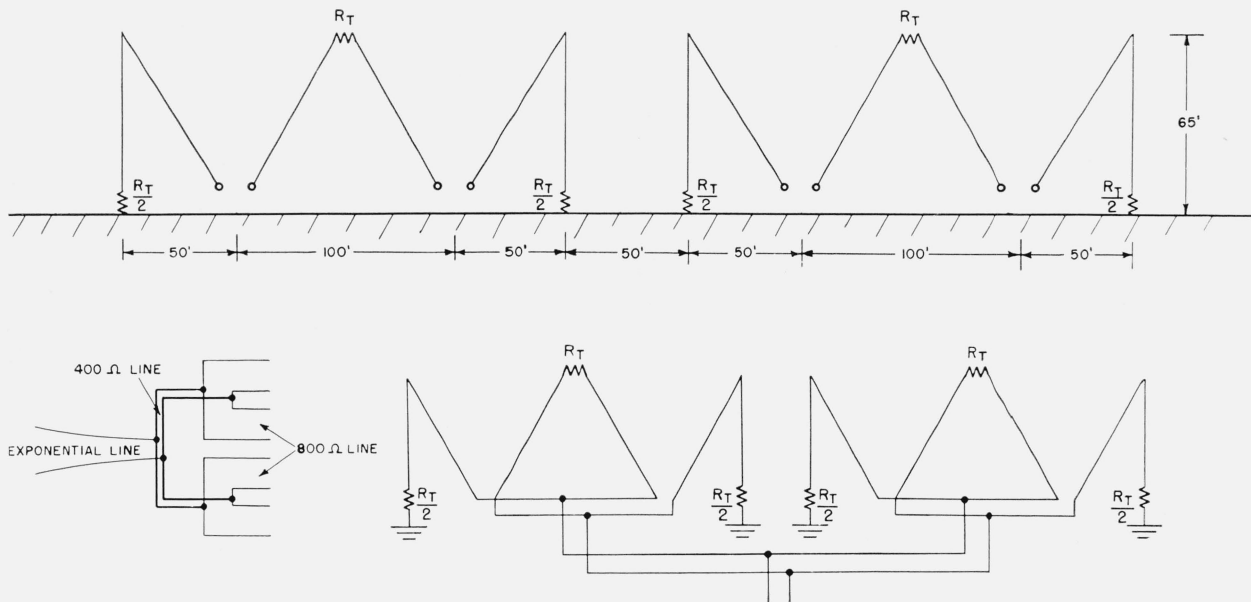

FIGURE 13. Construction of double-*W* antenna and associated transmission line system.

10-kw power is quite complicated. The most promising solution appeared to be an exponential-line transformer.² Such a line is reasonably flat at all frequencies substantially greater than the cut-off frequency. Since, for this application, a frequency range of 1 to 25 Mc/s was desired, the cut-off frequency of the line should be considerably below 1 Mc/s if impedance variations at the lower frequencies were to be minimized. However, if the cut-off frequency was too low, the line would be inconveniently long.

An exponential line transformer was therefore designed for an impedance transformation of 200 to 600 ohms and for a cut-off frequency of 300 kc. The resulting line was 88 m long. The performance of this line as a transformer when terminated

² H. A. Wheeler, IRE 27, 65 (Jan. 1939); C. R. Burrows, Bell Sys. Tech. J. 17, 555 (Oct. 1938); W. N. Christiansen, Proc. IRE 34, 576 (June 1947).

with a pure resistance of 200 ohms is shown in figure 14. Figure 15 shows the impedance characteristic of the entire transmission-line system used with the double-*W* antenna, including the exponential-line transformer, the 800-ohm lines being terminated with resistance of 800 ohms. Impedance measurements were made of the antenna for values of R_T equal to 800, 1,000, and 1,200 ohms. Figure 16 shows the best results obtained with this antenna, which were secured using a 1,000-ohm termination. Over most of

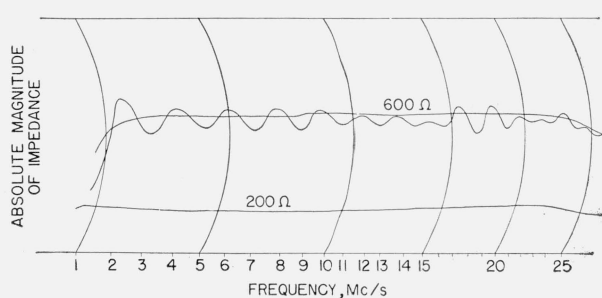

FIGURE 14. Impedance of exponential transmission line.

Line terminated with 200-ohm resistor.

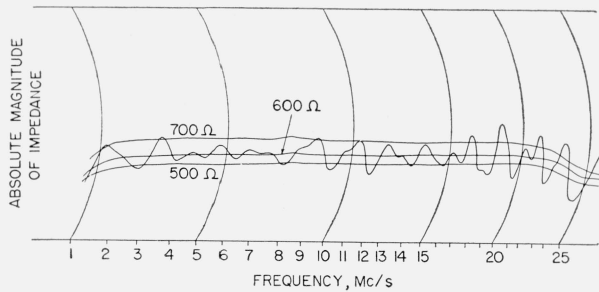

FIGURE 15. Impedance of entire transmission line system used with double W antenna.

800-ohm lines terminated with 800-ohm resistors.

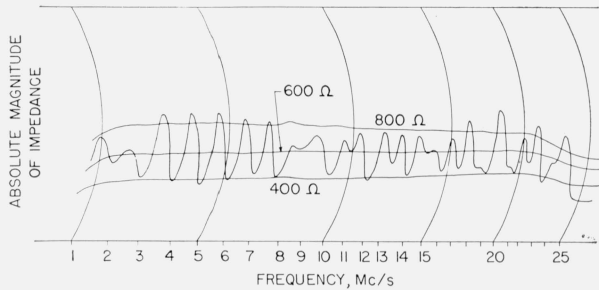

FIGURE 16. Impedance of double-W antenna for optimum termination of 1,000 ohms.

An attempt was made to determine the approximate radiation efficiency of the antenna system by measuring the power absorbed by the antenna and its associated transmission-line system and the power dissipated in the terminal resistors. This measurement is possible at frequencies at which the impedance of the antenna is a pure resistance. These are the frequencies at which the impedance of the antenna is a maximum or a minimum. The power input to the antenna system is given by the expression

$$\frac{E_a^2}{R_a}$$

The power input to the terminating resistors is given by the sum of

$$\frac{E_1^2}{R_1} + \frac{E_2^2}{R_2} + \frac{E_3^2}{R_3} + \dots + \frac{E_r^2}{R_r} + \dots + \frac{E_n^2}{R_n}$$

In these expressions R_a is the value of the input impedance (resistive) of the antenna; $R_1, R_2, \dots, R_r, \dots, R_n$ are the values of the various terminating resistors, E_a is the rms input voltage to the antenna; and $E_1, E_2, \dots, E_r, \dots, E_n$ are the

Experimental Broad-Band Antennas

rms voltages across the respective terminating resistors.

Then the efficiency of the antenna as a radiator is given by the relationship:

$$EFF = \frac{E_a^2 - \sum_{r=1}^{r=n} E_r^2}{E_a^2} = 1 - \frac{R_a \sum_{r=1}^{r=n} E_r^2}{E_a^2 R_r}$$

It should be noted that the copper, dielectric, and ground losses are all included in the power radiated, and hence the efficiency of the antenna thus obtained is somewhat higher than the true radiation efficiency.

At 3.6 Mc/s, the radiation efficiency of the antenna as measured by this method was found to be approximately 39 percent.

Measurements were made that indicated that each vee had an average input impedance somewhat higher than 800 ohms. An attempt was made to reduce this impedance by constructing the vees with spaced parallel wires, 6-in. spacing being used. The results are shown in figure 17. Comparing figures 16 and 17, it can be seen that, considering the entire frequency range, the single-wire double-W antenna is more desirable. However, for certain limited frequency ranges, the parallel-wave antenna has smaller impedance variations.

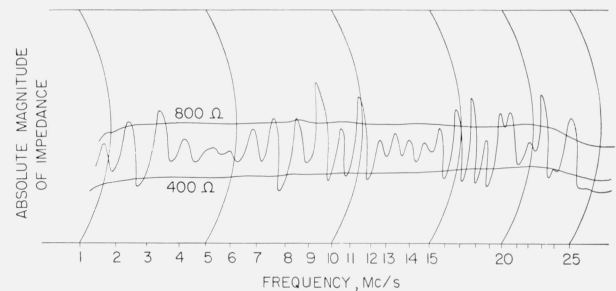

FIGURE 17. Impedance of parallel wire double-W antenna.

IV. Conclusions

1. The input impedance of the delta antenna over the frequency range 1 to 25 Mc/s can be lowered and variations minimized, to the point where it is practical to use a transmission line to feed it, by the use of multiple wires in its construction.

2. The size and spacing of the wires parallel to the ground have a decided effect on the input impedance of the multiple-wire delta antenna.

3. The input impedance variations of the experimental double-*W* antenna were of the same order of magnitude as those obtained with the single-wire delta. However, preliminary measurements indicate that the radiation efficiency of the

double-*W* antenna is somewhat higher than that of the single-wire delta antenna, particularly at the lower frequencies. The double-*W* antenna is, however, physically large, and its radiation pattern has not yet been determined.

WASHINGTON, March 31, 1949.

National Bureau of Standards
Library, N. W. Bldg.
NOV 16 1949

U. S. DEPARTMENT OF COMMERCE
NATIONAL BUREAU OF STANDARDS
CENTRAL RADIO PROPAGATION LABORATORY
WASHINGTON, D. C.

INTERIM REPORT ON EXPERIMENTAL
BROAD-BAND ANTENNAS FOR VERTICAL
INCIDENCE IONOSPHERE SOUNDING

BY H. N. CONES

NATIONAL BUREAU OF STANDARDS
CENTRAL RADIO PROPAGATION LABORATORY
WASHINGTON 25, D. C.

INTERIM REPORT ON EXPERIMENTAL BROAD-BAND ANTENNAS
FOR VERTICAL INCIDENCE IONOSPHERE SOUNDING

By H. N. CONES

ABSTRACT

This paper presents the results of measurements of the modulus of input impedance of a number of non-resonant antennas over a continuous frequency range from 1 to 25 Mc/s. These antennas were constructed as part of a design problem of developing an effective radiating system for vertical incidence ionospheric sounding equipment. The data are in the form of curves and the antennas are compared with each other from the standpoint of uniformity of impedance over the frequency range. The use of multiple wire construction to lower the average input impedance, to minimize impedance variations, and to increase radiation efficiency is discussed.

I. General

The delta antenna (illustrated in Figs. 2A and 3A) has a number of characteristics which make it attractive as an antenna for vertical-incidence ionospheric work. It is fairly compact, requiring only a single large mast, and is easy to erect. However, its input impedance, even when properly terminated, may vary from as low as 300 ohms to as much as 1200 or 1400 ohms over the frequency range of 1-25 Mc/s, and the use of a transmission line to feed the antenna causes an even greater impedance variation. Furthermore, the radiation efficiency at the lower frequencies of the operating range is quite small.

The vertical rhombic antenna, which is another form of non-resonant antenna frequently used for ionospheric measurements, is somewhat more difficult to construct than the delta, requiring one large mast and two smaller ones. Theoretical considerations lead to the conclusion that the impedance characteristics of a vertical rhombic antenna should be somewhat more uniform than that of a delta. However, the tests performed thus far were limited to existing rhombic antennas which were not designed for optimum impedance characteristics. Theoretical considerations would also lead one to believe that the radiating

efficiency of a vertical rhombic antenna which is small compared to the wavelength used would be lower than a delta or vee antenna designed for the same frequency range.

Elementary considerations indicate that the radiated field of a nonresonant antenna would be proportional to the product of the current flowing through the antenna and the length of the antenna, and is some function of the configuration of the antenna. Because physical limitations restrict the height and, therefore, the length of the antenna, the most promising approach to a more efficient radiator is a multiple wire antenna. Effectively, this lowers the impedance of the antenna, permitting increased current for a given input power. A qualitative analysis indicates that increased radiation efficiency may be thus obtained. Furthermore, because a multiple-wire antenna permits adjustment of wire spacing along its length, it appears to offer a possibility of also securing a more uniform impedance characteristic over the entire frequency range.

The remainder of this report describes the technics and results of experimental impedance measurements of the following types of antennas:

1. Single-wire delta antennas.
2. A series of multiple wire delta antennas.
3. A vertical W antenna.
4. A vertical double-W antenna.

II. Instrumentation

For measurement of antenna impedance a balanced recording impedance meter developed at the National Bureau of Standards was used. A description of this instrument was presented at the Winter 1946-47 IRE convention in New York City, and will be published in the near future. Fig. 1 presents the block diagrams of the instrument. Briefly, it consists of a 57 Mc/s fixed-frequency oscillator beating with a variable frequency oscillator covering the band from 57 to 82 Mc/s. The difference frequency of 0 - 25 Mc/s is passed through a wide-band amplifier designed to have a constant current output. The output voltage is therefore directly proportional to the absolute magnitude of impedance connected across the output terminals; no direct indication of the phase angle of the impedance has thus far been provided. This voltage is rectified, amplified and applied to a recording milliammeter. The recording milliammeter and the variable frequency oscillator are mechanically coupled so that the impedance is plotted as a function of frequency. A voltage stabilizer is incorporated to insure constant output current. The instrument is calibrated by substituting non-inductive resistors for the unknown impedance.

III. Results of Measurements

Fig. 2A shows the construction of a simple form of single-wire delta antenna. The principle of a delta antenna is similar to that of a terminated

vertical vee in the higher portion of its frequency range; at lower frequencies it behaves somewhat like a loop. The delta construction minimizes the number of supports required and serves to solve the problem of termination. Measurements of the impedance of the antenna shown in Fig. 2A were made for values of terminating resistance, R_T , equal to 800, 1000, 1200, 1400 and 1600 ohms. Fig 2B shows the impedance of the antenna over the frequency range of 1 through 25 Mc/s using a terminating resistance of 1000 ohms, which was found to be optimum for minimum variation of input impedance. The range of input impedance in this case was from 300 to 1200 ohms. The value of R_T was not particularly critical since the range of input impedance for the 800-ohm termination was 300 to 1300 ohms and for the 1600-ohm termination was 300 to 1200 ohms. The impedance at frequencies from 16 to 25 Mc/s was only slightly affected by changes in terminating resistance. At frequencies below 8 Mc/s the impedance characteristics were influenced to a much greater degree by different values of terminating resistance, the number and location of the peaks being changed, although the maximum and minimum values of impedance remained about the same.

Fig. 3A shows the construction of a variation of delta antenna designed by Mr. J.W. Cox of the Baddow Research Laboratories of the British Marconi Company. It is distinguished from the simpler delta by the presence of corkscrew turns at the lower corners of the antenna. These turns are intended to improve the performance of the antenna. Fig. 3B shows the impedance characteristics of this antenna. It can be seen that with optimum terminating resistor (R_T equal to 1200 ohms), the impedance varied from less than 400 ohms to approximately 1100 ohms, and it appears that the impedance characteristics of the antenna were not appreciably improved by the addition of the corkscrew turns.

The first multiple-wire delta constructed was identical in size and shape to the antenna shown in Fig. 2A except it was constructed using two parallel wires spaced 15 inches apart. Measurements were made using a number of different terminations. Fig. 4 shows the impedance characteristics of this antenna for an optimum termination of 600 ohms. The impedance in this case varied from 300 to 850 ohms. It should be noted that the parallel-wire delta terminated with 600 ohms was superior from the standpoint of uniformity of impedance to the single-wire delta terminated with 1000 ohms. The impedance is lower and the variation small enough so that it would be practical to use a 600-ohm line to feed it.

Several other types of multiple-wire deltas were constructed. The best results were obtained when the oblique wires had the configuration shown in Fig. 5. Each leg consisted of two wires joined at the apex and the lower corners and flayed 36 inches apart at a point 18 feet from the lower corner. The exact position of the spreaders is not critical nor is the plane of the wires. The horizontal wires, however, have a very significant effect on the impedance characteristics of the antenna. Tests were, therefore, made in which the arrangement of oblique wires shown in Fig. 5 remained unchanged and with the various arrangements of horizontal wires shown in the same Fig. Referring to Fig. 6, curve A shows the impedance when only a single # 12 wire was used on each side. Curve B shows the results obtained by replacing the single wire by

two #18 wires spaced 0.3 inches apart and connected in parallel. Curve C shows the results when 4 #18 wires were connected in parallel, and curve D the results when the bottom wires consisted of 2 pairs of #18 wires connected in parallel and spaced 16 inches between pairs as shown in Fig. 5.

Fig. 7 shows that the high-frequency impedance characteristics can be improved at the expense of the low-frequency characteristic by changing the terminating resistance from 800 to 600 ohms.

The W antenna, the construction of which is shown in Fig. 8A, is essentially two vertical-vee antennas excited in phase. One side of each vee terminates in a common resistor R_T and the other sides are grounded by means of vertical wires connected to ground by another resistor equal to one-half the value of R_T . The vees are fed by 800-ohm lines which join to form a 400-ohm line. The impedance characteristic of the transmission-line system with the 800-ohm lines being terminated by 800-ohm resistors is shown in Fig. 8B. Impedance measurements of the antenna were made for values of R_T equal to 600, 800, 1000, 1200, and 1400 ohms. Fig. 8C shows the impedance characteristics of this antenna with the optimum termination of 1000 ohms between the two vee antennas and with 500 ohms on each side. For R_T equal to 600 ohms the impedance variation was between 200 and 800 ohms over the entire range. Over most of the range, however, the impedance variation was only about 2:1. For R_T equal to 1400 ohms the impedance variation is only slightly greater than for the 1000-ohm termination.

Another section of the W antenna was constructed to make a double-W antenna (four vertical vees all excited in phase). This antenna system is shown in Fig. 9A. Each vee was fed with an 800-ohm line, pairs of 800-ohm lines being paralleled and fed with 400-ohm lines. The two resulting 400-ohm lines also were fed in parallel. The impedance looking into the transmission-line system was, therefore, 200 ohms. Since 200 ohms is not a suitable load for current designs of multi-frequency ionosphere recorders, it is necessary to introduce an impedance transformer. The design of an rf transformer aperiodic over a frequency range of 1-25 Mc and capable of handling 10-kw power is quite complicated. The most promising solution appeared to be an exponential-line transformer^{1,2,3/}. Such a line is reasonably flat at all frequencies substantially greater than the cutoff frequency. Since, for this application, a frequency range of 1-25 Mc/s was desired, the cutoff frequency of the line should be considerably below 1 Mc/s if impedance variations at the lower frequencies are to be minimized. However, if the cutoff frequency is too low, the line will be inconveniently long.

An exponential line transformer was therefore designed for an impedance transformation of 200 to 600 ohms and for a cutoff frequency of 300 kc. The resulting line was 88 meters long. The performance of this line as a transformer when terminated with a pure resistance of 200 ohms is shown in Fig. 9B. Fig. 9C shows the impedance characteristic of the entire transmission-line system used with the double-W antenna, including the exponential-line trans-

vertical vee in the higher portion of its frequency range; at lower frequencies it behaves somewhat like a loop. The delta construction minimizes the number of supports required and serves to solve the problem of termination. Measurements of the impedance of the antenna shown in Fig. 2A were made for values of terminating resistance, R_T , equal to 800, 1000, 1200, 1400 and 1600 ohms. Fig 2B shows the impedance of the antenna over the frequency range of 1 through 25 Mc/s using a terminating resistance of 1000 ohms, which was found to be optimum for minimum variation of input impedance. The range of input impedance in this case was from 300 to 1200 ohms. The value of R_T was not particularly critical since the range of input impedance for the 800-ohm termination was 300 to 1300 ohms and for the 1600-ohm termination was 300 to 1200 ohms. The impedance at frequencies from 16 to 25 Mc/s was only slightly affected by changes in terminating resistance. At frequencies below 8 Mc/s the impedance characteristics were influenced to a much greater degree by different values of terminating resistance, the number and location of the peaks being changed, although the maximum and minimum values of impedance remained about the same.

Fig. 3A shows the construction of a variation of delta antenna designed by Mr. J.W. Cox of the Baddow Research Laboratories of the British Marconi Company. It is distinguished from the simpler delta by the presence of corkscrew turns at the lower corners of the antenna. These turns are intended to improve the performance of the antenna. Fig. 3B shows the impedance characteristics of this antenna. It can be seen that with optimum terminating resistor (R_T equal to 1200 ohms), the impedance varied from less than 400 ohms to approximately 1100 ohms, and it appears that the impedance characteristics of the antenna were not appreciably improved by the addition of the corkscrew turns.

The first multiple-wire delta constructed was identical in size and shape to the antenna shown in Fig. 2A except it was constructed using two parallel wires spaced 15 inches apart. Measurements were made using a number of different terminations. Fig. 4 shows the impedance characteristics of this antenna for an optimum termination of 600 ohms. The impedance in this case varied from 300 to 850 ohms. It should be noted that the parallel-wire delta terminated with 600 ohms was superior from the standpoint of uniformity of impedance to the single-wire delta terminated with 1000 ohms. The impedance is lower and the variation small enough so that it would be practical to use a 600-ohm line to feed it.

Several other types of multiple-wire deltas were constructed. The best results were obtained when the oblique wires had the configuration shown in Fig. 5. Each leg consisted of two wires joined at the apex and the lower corners and flayed 36 inches apart at a point 18 feet from the lower corner. The exact position of the spreaders is not critical nor is the plane of the wires. The horizontal wires, however, have a very significant effect on the impedance characteristics of the antenna. Tests were, therefore, made in which the arrangement of oblique wires shown in Fig. 5 remained unchanged and with the various arrangements of horizontal wires shown in the same Fig. Referring to Fig. 6, curve A shows the impedance when only a single # 12 wire was used on each side. Curve B shows the results obtained by replacing the single wire by

two #18 wires spaced 0.3 inches apart and connected in parallel. Curve C shows the results when 4 #18 wires were connected in parallel, and curve D the results when the bottom wires consisted of 2 pairs of #18 wires connected in parallel and spaced 16 inches between pairs as shown in Fig. 5.

Fig. 7 shows that the high-frequency impedance characteristics can be improved at the expense of the low-frequency characteristic by changing the terminating resistance from 800 to 600 ohms.

The W antenna, the construction of which is shown in Fig. 8A, is essentially two vertical-vee antennas excited in phase. One side of each vee terminates in a common resistor R_T and the other sides are grounded by means of vertical wires connected to ground by another resistor equal to one-half the value of R_T . The vees are fed by 800-ohm lines which join to form a 400-ohm line. The impedance characteristic of the transmission-line system with the 800-ohm lines being terminated by 800-ohm resistors is shown in Fig. 8B. Impedance measurements of the antenna were made for values of R_T equal to 600, 800, 1000, 1200, and 1400 ohms. Fig. 8C shows the impedance characteristics of this antenna with the optimum termination of 1000 ohms between the two vee antennas and with 500 ohms on each side. For R_T equal to 600 ohms the impedance variation was between 200 and 800 ohms over the entire range. Over most of the range, however, the impedance variation was only about 2:1. For R_T equal to 1400 ohms the impedance variation is only slightly greater than for the 1000-ohm termination.

Another section of the W antenna was constructed to make a double-W antenna (four vertical vees all excited in phase). This antenna system is shown in Fig. 9A. Each vee was fed with an 800-ohm line, pairs of 800-ohm lines being paralleled and fed with 400-ohm lines. The two resulting 400-ohm lines also were fed in parallel. The impedance looking into the transmission-line system was, therefore, 200 ohms. Since 200 ohms is not a suitable load for current designs of multi-frequency ionosphere recorders, it is necessary to introduce an impedance transformer. The design of an rf transformer aperiodic over a frequency range of 1-25 Mc and capable of handling 10-kw power is quite complicated. The most promising solution appeared to be an exponential-line transformer^{1,2,3}. Such a line is reasonably flat at all frequencies substantially greater than the cutoff frequency. Since, for this application, a frequency range of 1-25 Mc/s was desired, the cutoff frequency of the line should be considerably below 1 Mc/s if impedance variations at the lower frequencies are to be minimized. However, if the cutoff frequency is too low, the line will be inconveniently long.

An exponential line transformer was therefore designed for an impedance transformation of 200 to 600 ohms and for a cutoff frequency of 300 kc. The resulting line was 88 meters long. The performance of this line as a transformer when terminated with a pure resistance of 200 ohms is shown in Fig. 9B. Fig. 9C shows the impedance characteristic of the entire transmission-line system used with the double-W antenna, including the exponential-line trans-

former, the 800-ohm lines being terminated with resistance of 800 ohms. Impedance measurements were made of the antenna for values of R_T equal to 800, 1000, and 1200 ohms. Fig. 9D shows the best results obtained with this antenna which were secured using a 1000-ohm termination. Over most of the range the impedance varied between about 400 and 825 ohms. The impedance variation for a value of R_T equal to 1200 ohms was 300 to 1100 ohms and for a value of R_T equal to 800 ohms was from 400 to 900 ohms.

An attempt was made to determine the approximate radiation efficiency of the antenna system by measuring the power absorbed by the antenna and its associated transmission-line system and the power dissipated in the terminal resistors. This measurement is possible at frequencies at which the impedance of the antenna is a pure resistance. These are the frequencies at which the impedance of the antenna is a maximum or a minimum. The power input to the antenna system is given by the expression

$$\frac{E_a^2}{R_a}$$

The power input to the terminating resistors is given by the sum of

$$\frac{E_1^2}{R_1} + \frac{E_2^2}{R_2} + \frac{E_3^2}{R_3} + \dots + \frac{E_r^2}{R_r} + \dots + \frac{E_n^2}{R_n}$$

In these expressions:

R_a is the value of the input impedance (resistive) of the antenna,

$R_1, R_2, \dots, R_r, \dots, R_n$ are the values of the various terminating resistors,

E_a is the rms input voltage to the antenna,

and $E_1, E_2, \dots, E_r, \dots, E_n$ are the rms voltages across the respective terminating resistors.

Then the efficiency of the antenna as a radiator is given by the relationship:

$$\begin{aligned} \text{EFF} &= \frac{\frac{E_a^2}{R_a} - \sum_{r=1}^{r=n} \frac{E_r^2}{R_r}}{\frac{E_a^2}{R_a}} \\ &= 1 - \frac{R_a}{E_a^2} \sum_{r=1}^{r=n} \frac{E_r^2}{R_r} \end{aligned}$$

It should be noted that the copper, dielectric, and ground losses are all included in the power radiated and hence the efficiency of the antenna thus obtained is somewhat higher than the true radiation efficiency.

At 3.6 Mc/s the radiation efficiency of the antenna as measured by this method was found to be approximately 39%.

Measurements were made which indicated that each vee had an average input impedance somewhat higher than 800 ohms. An attempt was made to reduce this impedance by constructing the vees with spaced parallel wires, six inch spacing being used. The results are shown in Fig. 9E. Comparing Figs. 9D and 9E it can be seen that, considering the entire frequency range, the single-wire double-W antenna is more desirable. However, for certain limited frequency ranges, the parallel-wave antenna has smaller impedance variations.

Conclusions

1. The input impedance of the delta antenna over the frequency range 1-25 Mc/s can be lowered and variations minimized, to the point where it would be practical to use a transmission line to feed it, by the use of multiple wires in its construction

2. The size and spacing of the wires parallel to the ground have a decided effect on the input impedance of the multiple-wire delta antenna.

3. The input impedance variations of the experimental double-W antenna were of the same order of magnitude as those obtained with the single-wire delta. However, preliminary measurements indicate that the radiation efficiency of the double-W antenna is somewhat higher than that of the single-wire delta antenna, particularly at the lower frequencies. The double-W antenna is, however, physically large, and its radiation pattern has not yet been determined.

References:

- (1) Wheeler, H.A., I.R.E., vol. 27, pp. 65-71; Jan. 1939.
- (2) Burrows, C.R., Bell Sys. Tech. Jour., vol. 17, pp. 555-573; Oct. 1938.
- (3) Christiansen, Proc. I.R.E., vol. 34, pp. 576-581; June 1947.

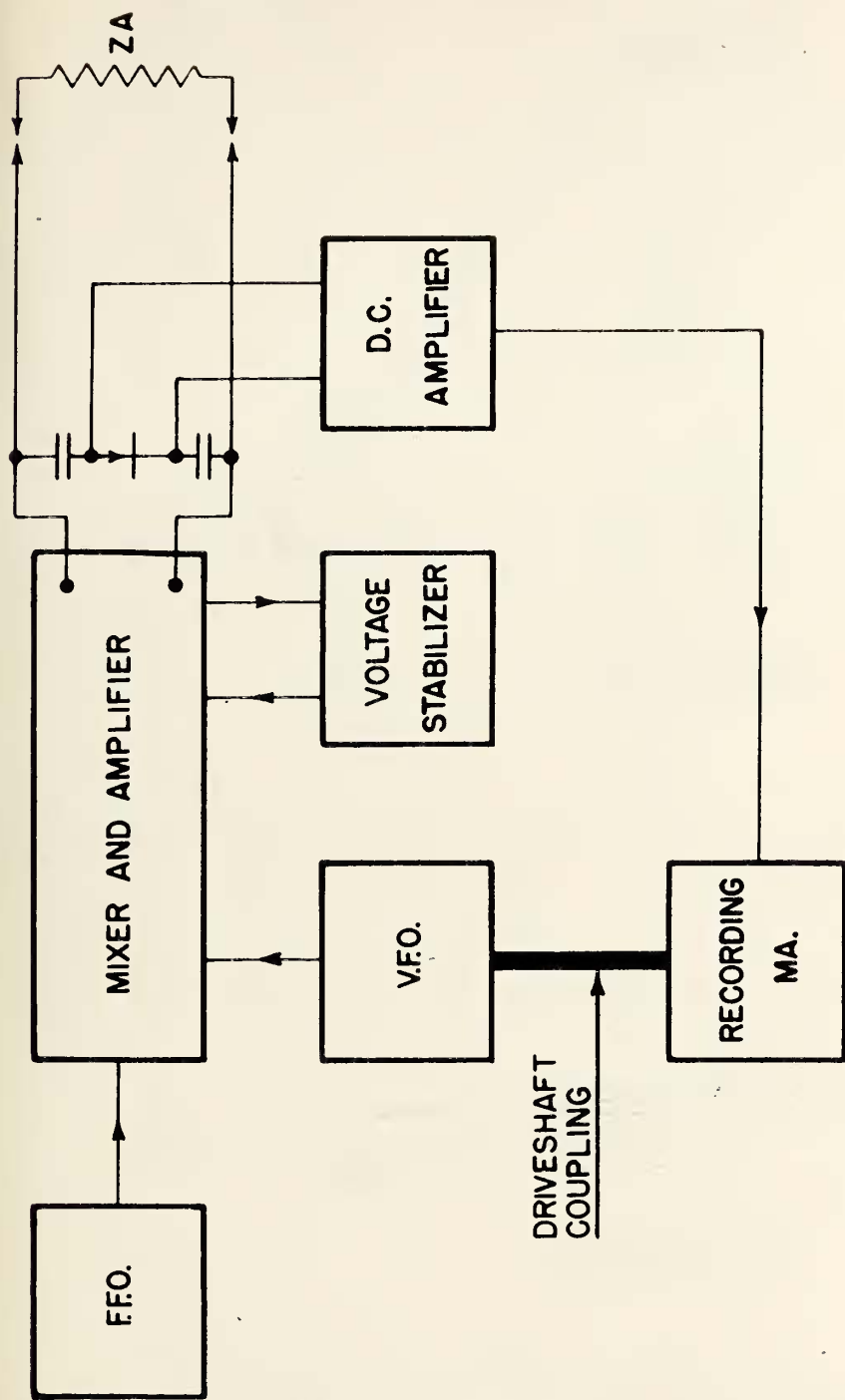
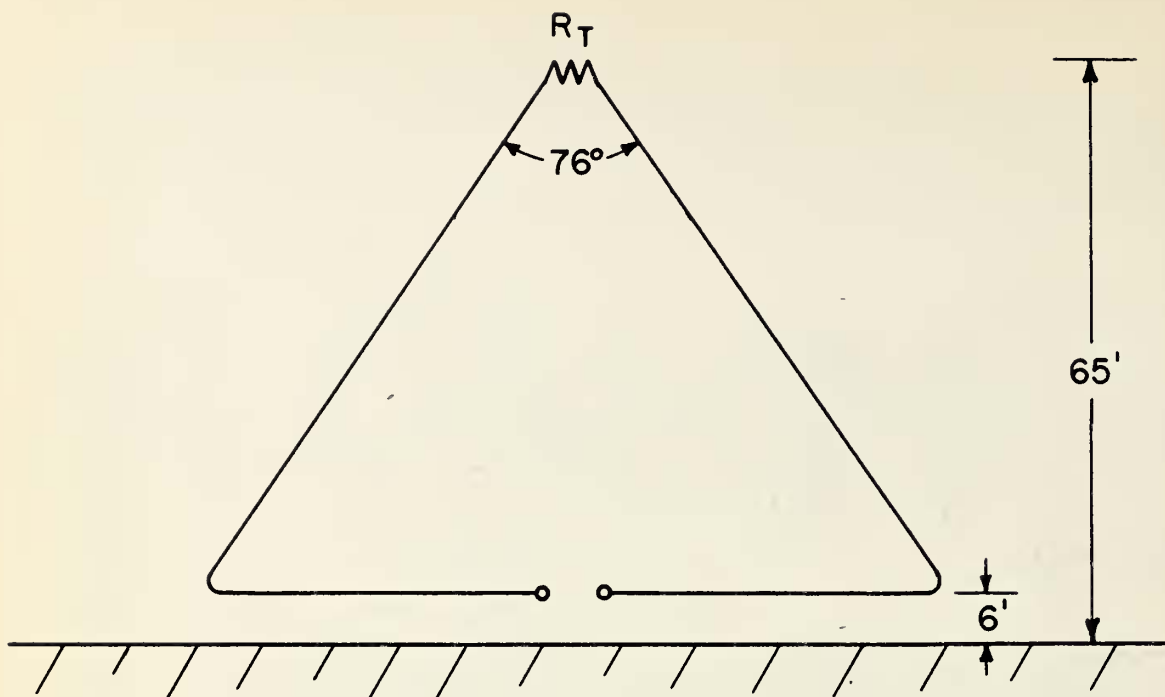
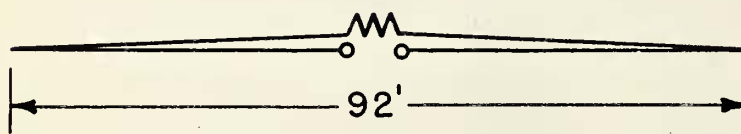

Fig. 1 BLOCK DIAGRAM OF IMPEDANCE METER



SIDE VIEW



PLAN VIEW

Fig. 2A CONSTRUCTION OF SINGLE WIRE DELTA ANTENNA

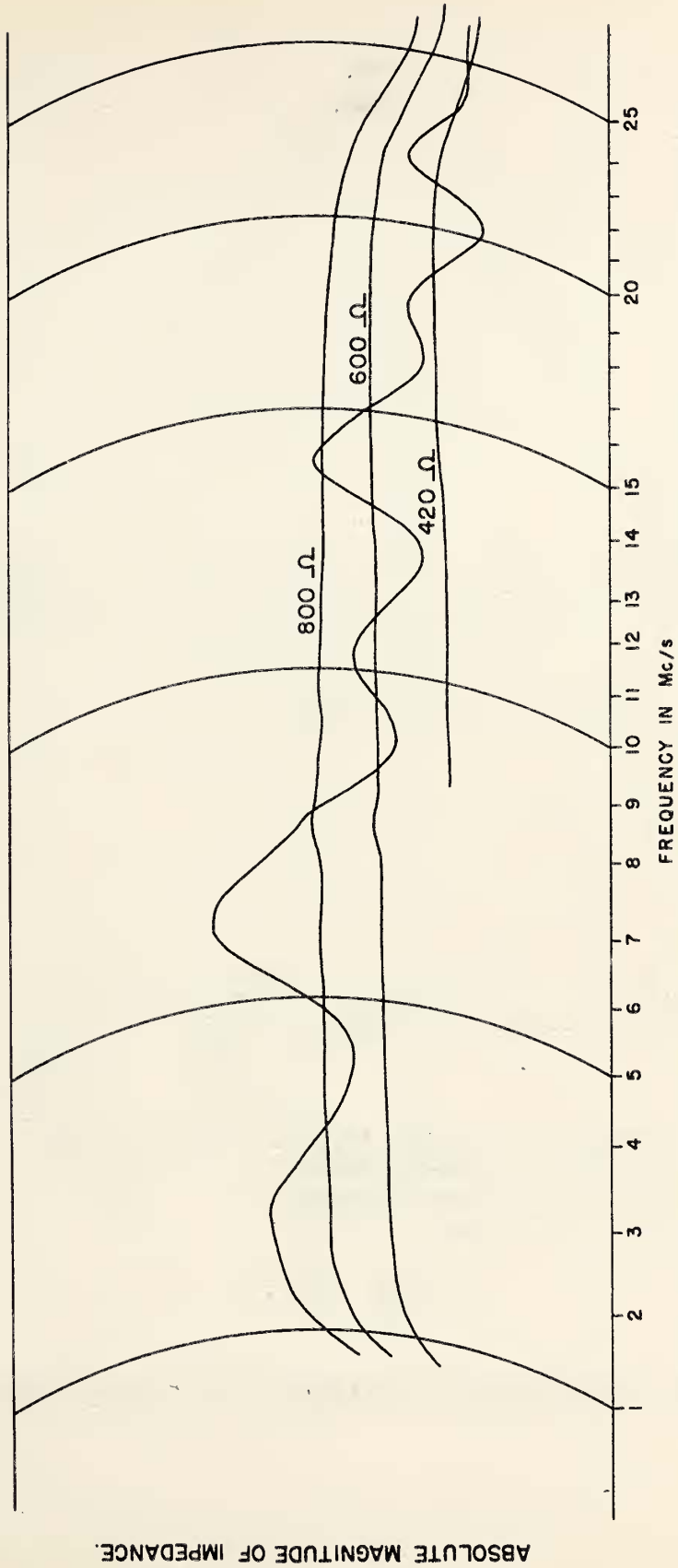
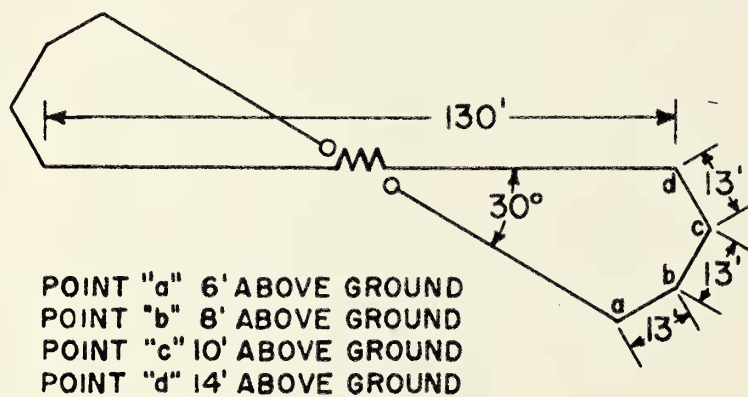
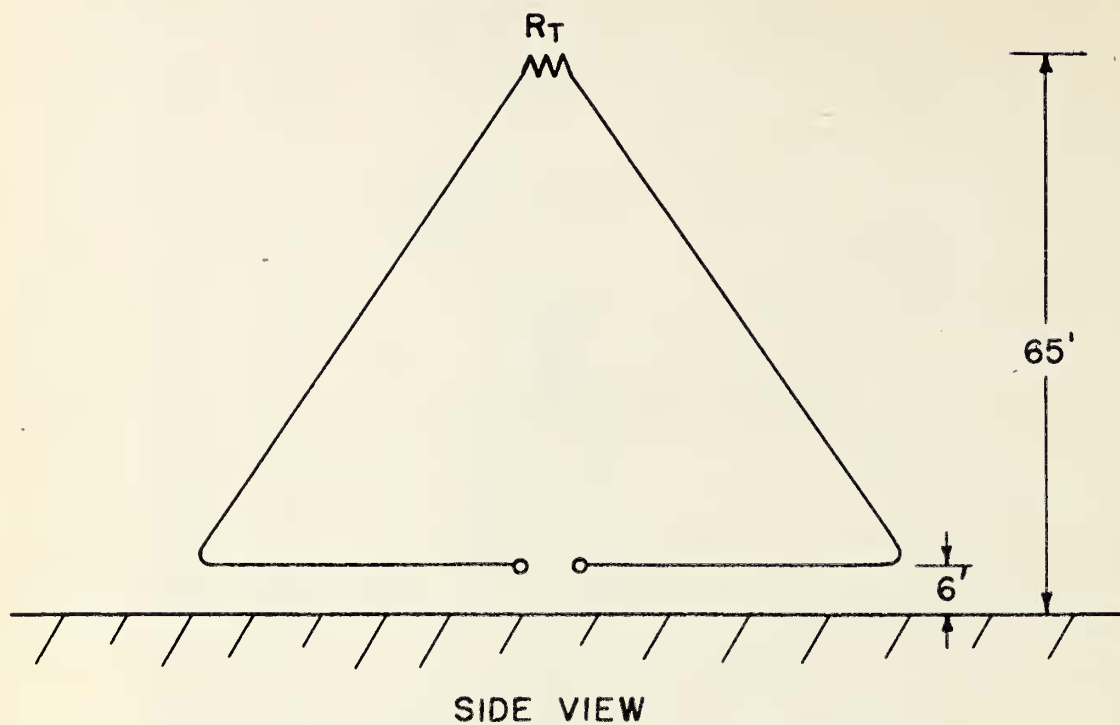

Fig. 2B. IMPEDANCE OF SINGLE WIRE DELTA ANTENNA FOR OPTIMUM TERMINATION OF 1000 OHMS.



POINT "a" 6' ABOVE GROUND
 POINT "b" 8' ABOVE GROUND
 POINT "c" 10' ABOVE GROUND
 POINT "d" 14' ABOVE GROUND

Fig. 3A CONSTRUCTION OF MODIFIED DELTA ANTENNA

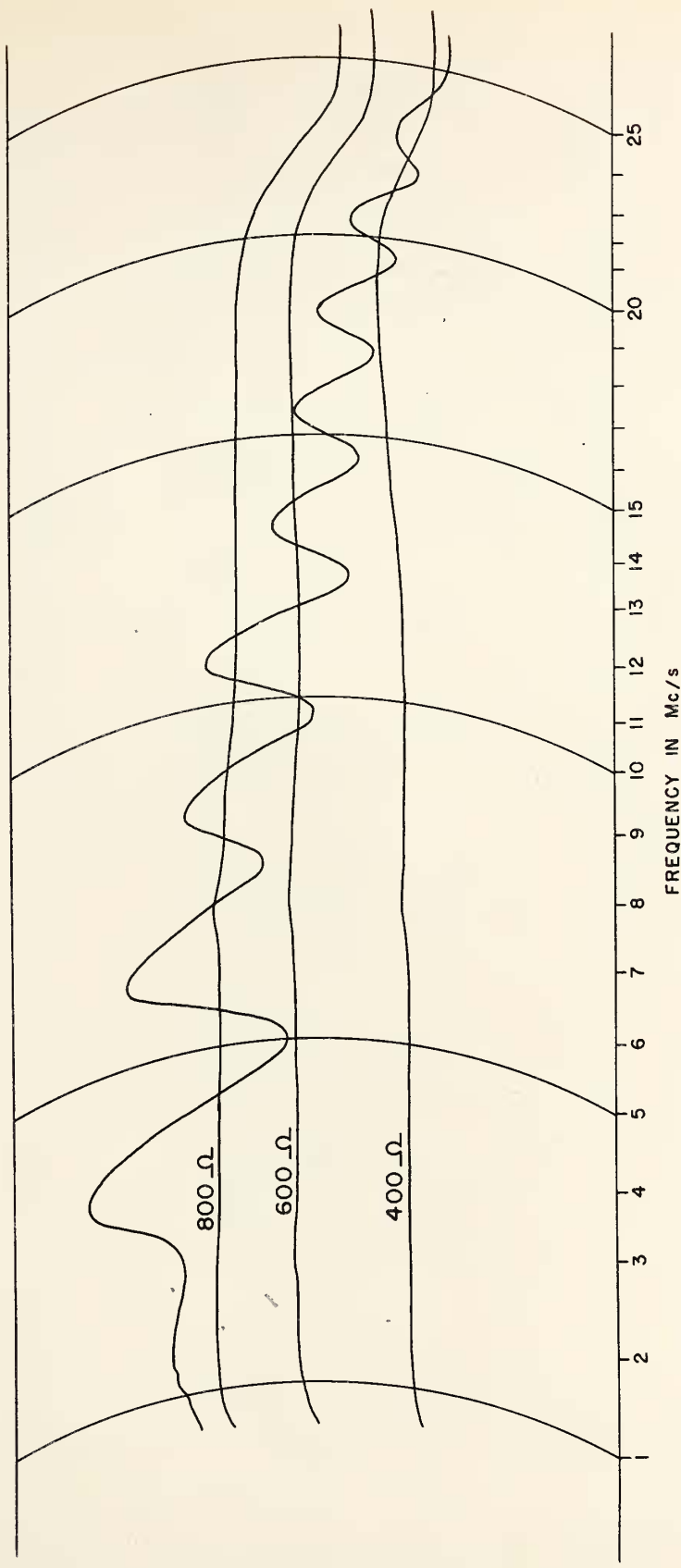
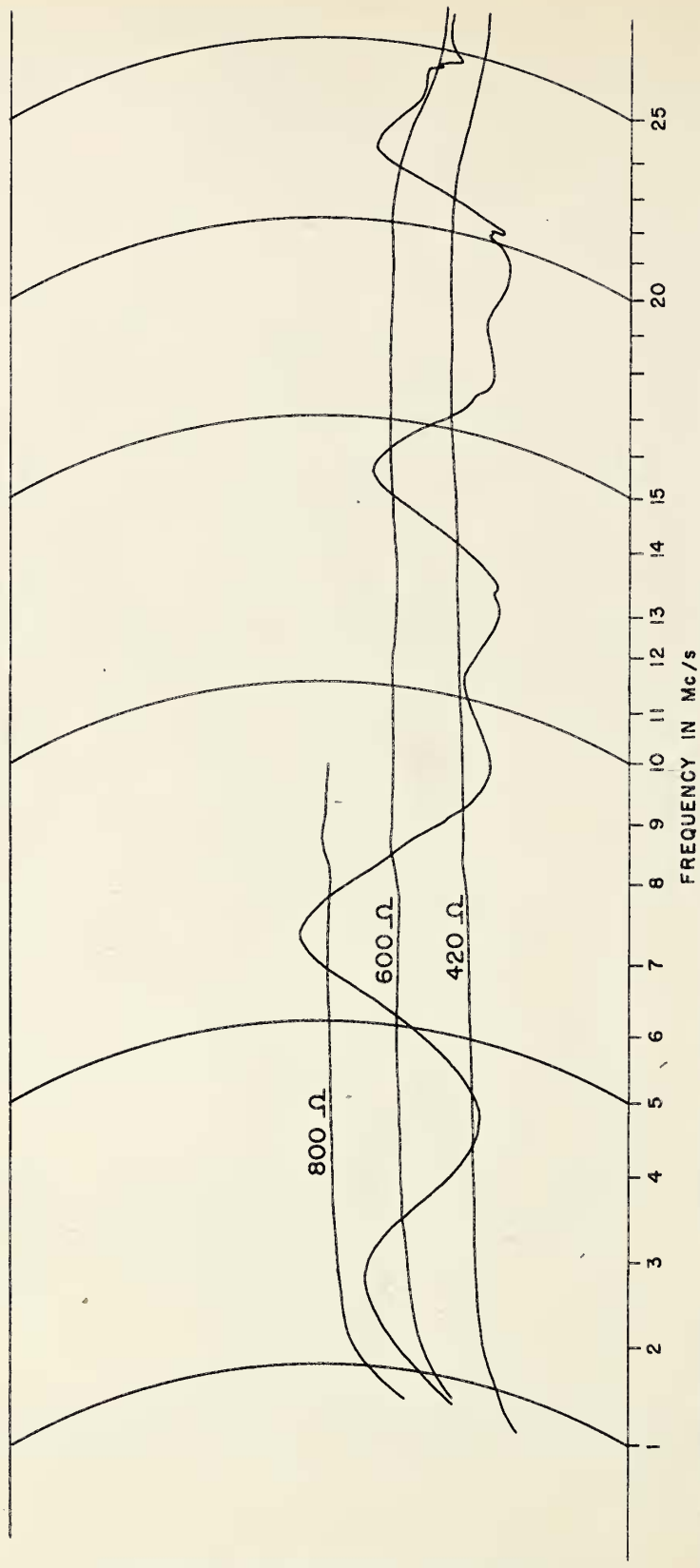
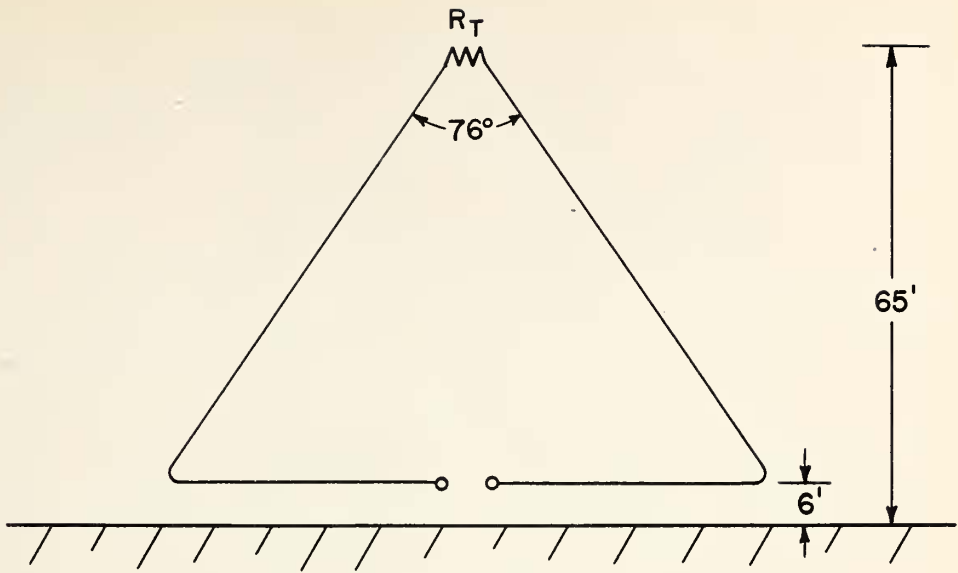

Fig. 3B. IMPEDANCE OF MODIFIED DELTA ANTENNA FOR OPTIMUM TERMINATION OF 1200 OHMS.



ABSOLUTE MAGNITUDE OF IMPEDANCE.

Fig. 4. IMPEDANCE OF PARALLEL WIRE DELTA ANTENNA. CONSTRUCTION IDENTICAL TO THAT OF FIG. 2A EXCEPT THAT TWO PARALLEL WIRES SPACED 15 INCHES APART ARE USED. $R_T = 600$ OHMS.



SIDE VIEW

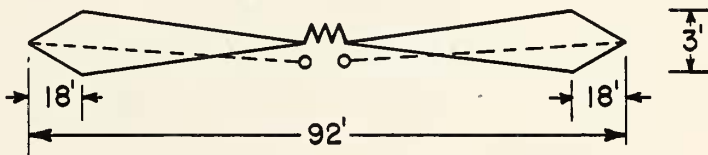

OBLIQUE WIRES
CURVES A,B,C,D. Fig.6

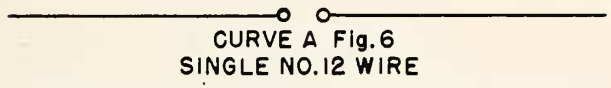

CURVE A Fig.6
SINGLE NO.12 WIRE



CURVE B Fig.6
2-NO.18 WIRES IN PARALLEL

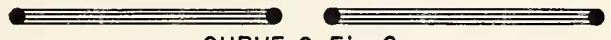

CURVE C Fig.6
4-NO.18 WIRES IN PARALLEL



CURVE D Fig.6
4-NO.18 WIRES IN PARALLEL
SPACED AS SHOWN

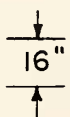

HORIZONTAL WIRES

Fig.5 CONFIGURATION OF OBLIQUE AND HORIZONTAL WIRES OF MULTIPLE WIRE DELTA ANTENNAS. IMPEDANCE CURVES SHOWN IN Fig.6.

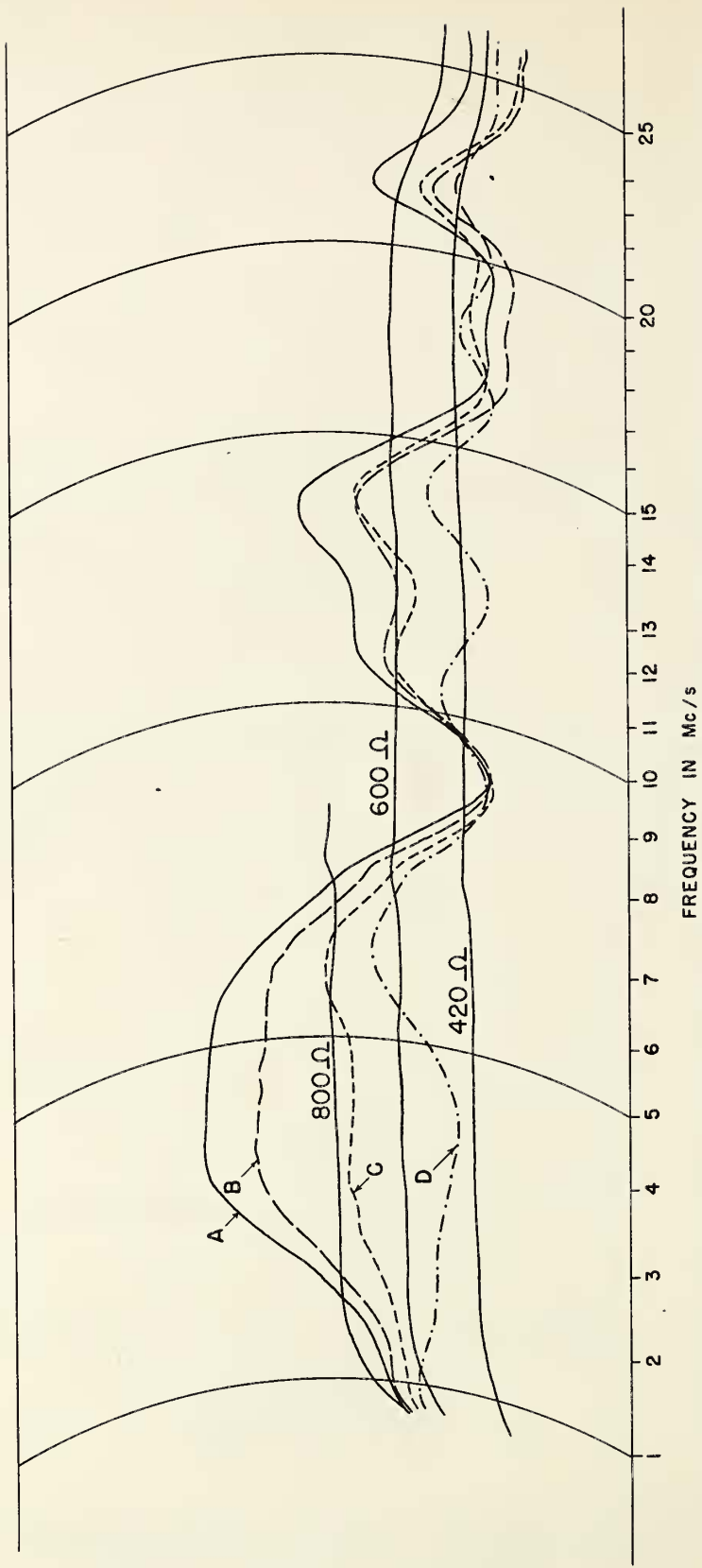

ABSOLUTE MAGNITUDE OF IMPEDANCE.

Fig. 6. IMPEDANCE OF MULTIPLE WIRE DELTA ANTENNAS. EACH ANTENNA TERMINATED WITH 800 OHM RESISTOR. CONSTRUCTIONAL DETAILS ARE SHOWN IN Fig. 5.

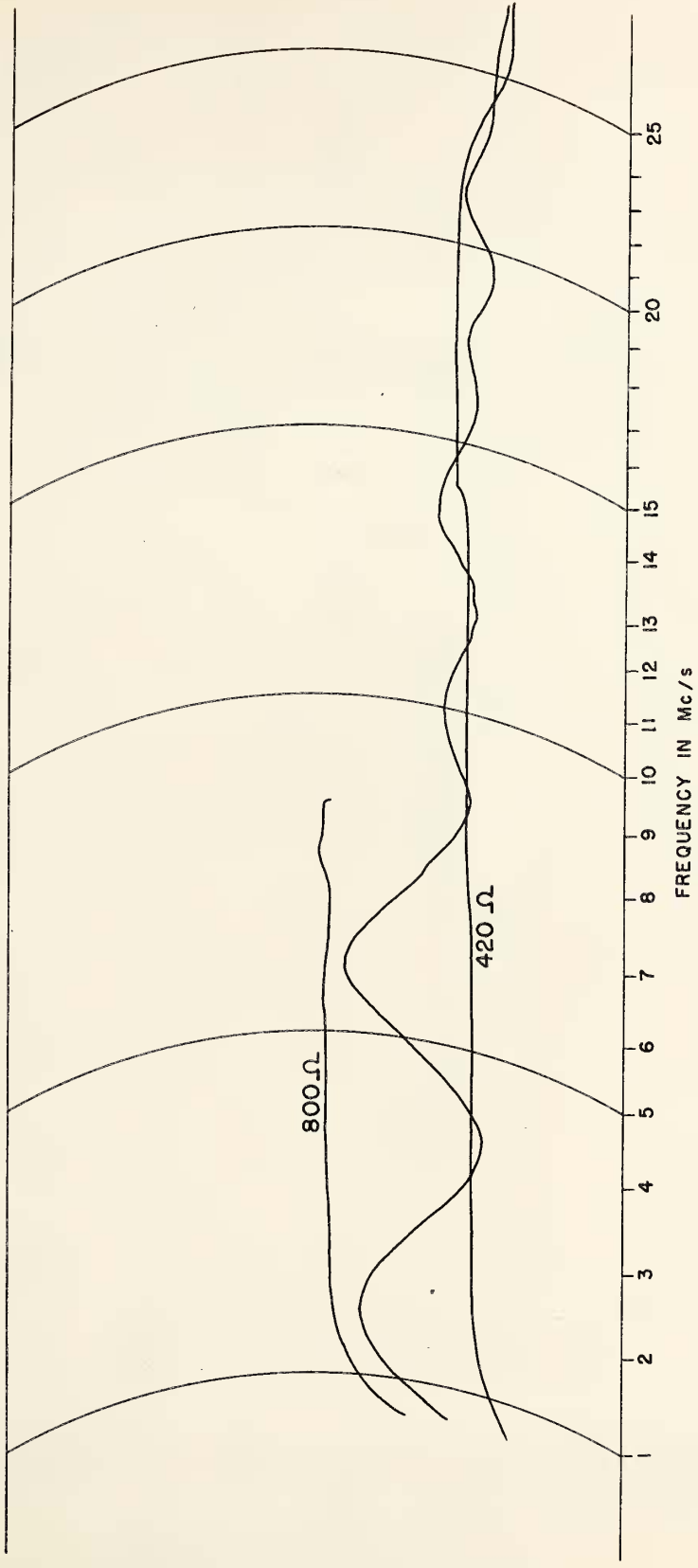

ABSOLUTE MAGNITUDE OF IMPEDANCE.

Fig. 7. IMPEDANCE OF MULTIPLE WIRE DELTA ANTENNA. SAME AS CURVE D FIG. 6 EXCEPT THAT VALUE OF TERMINATING RESISTOR IS 600 OHMS.

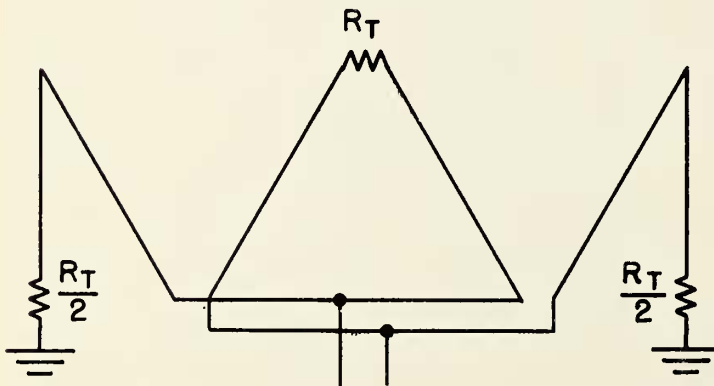
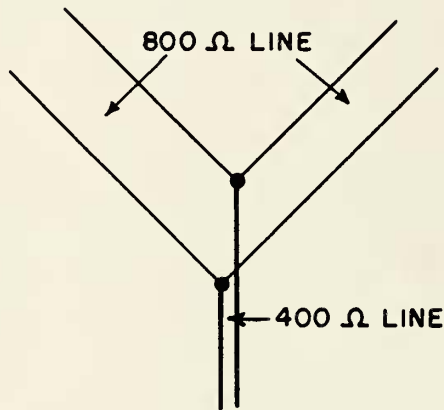
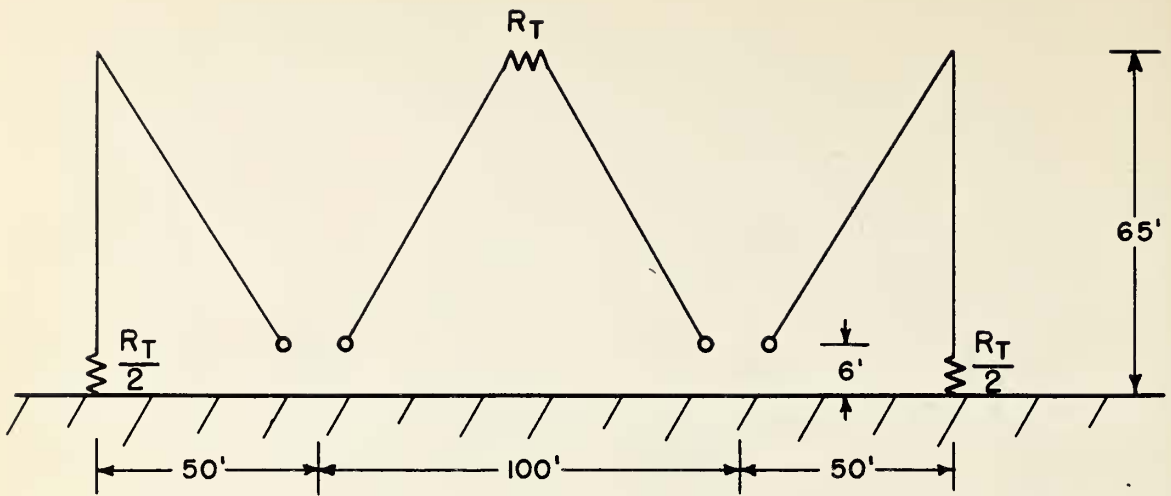
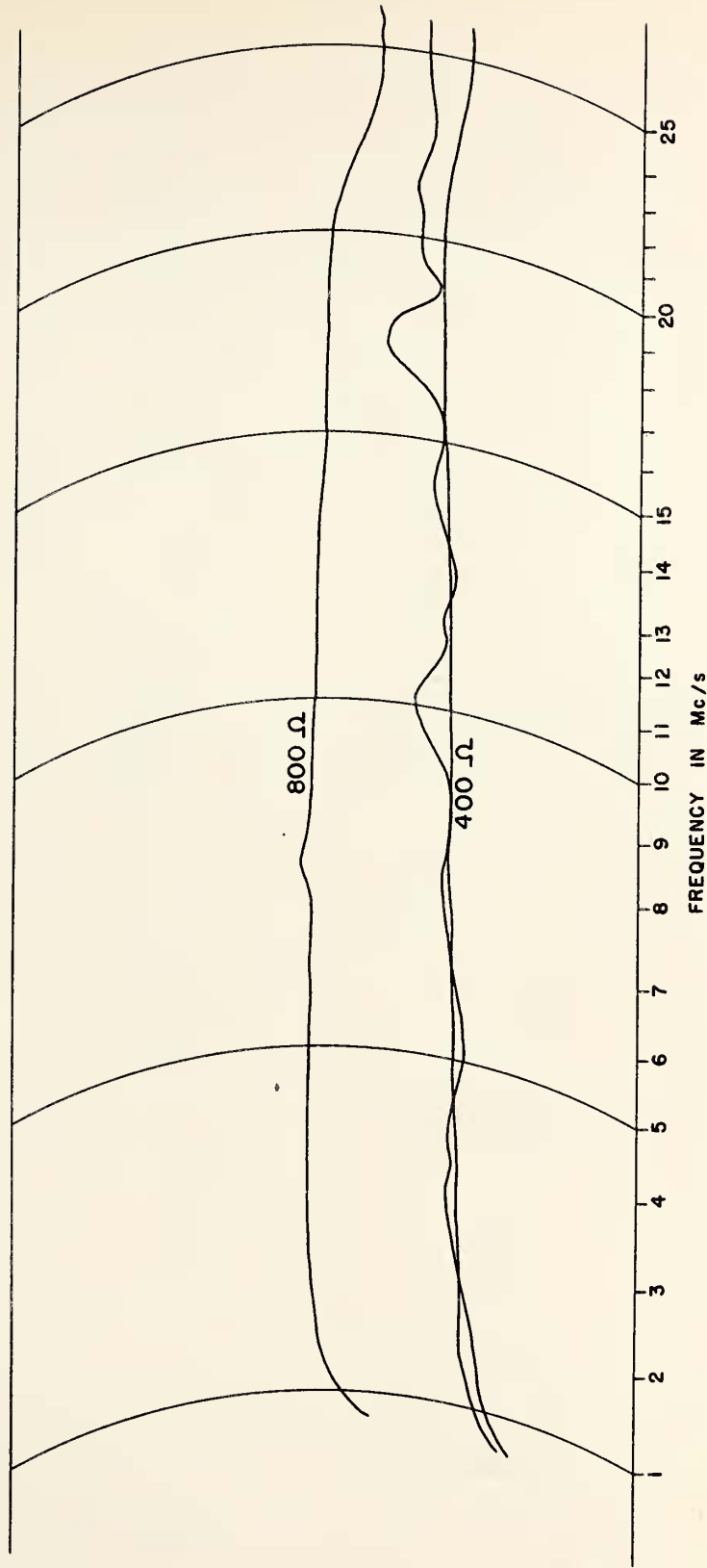
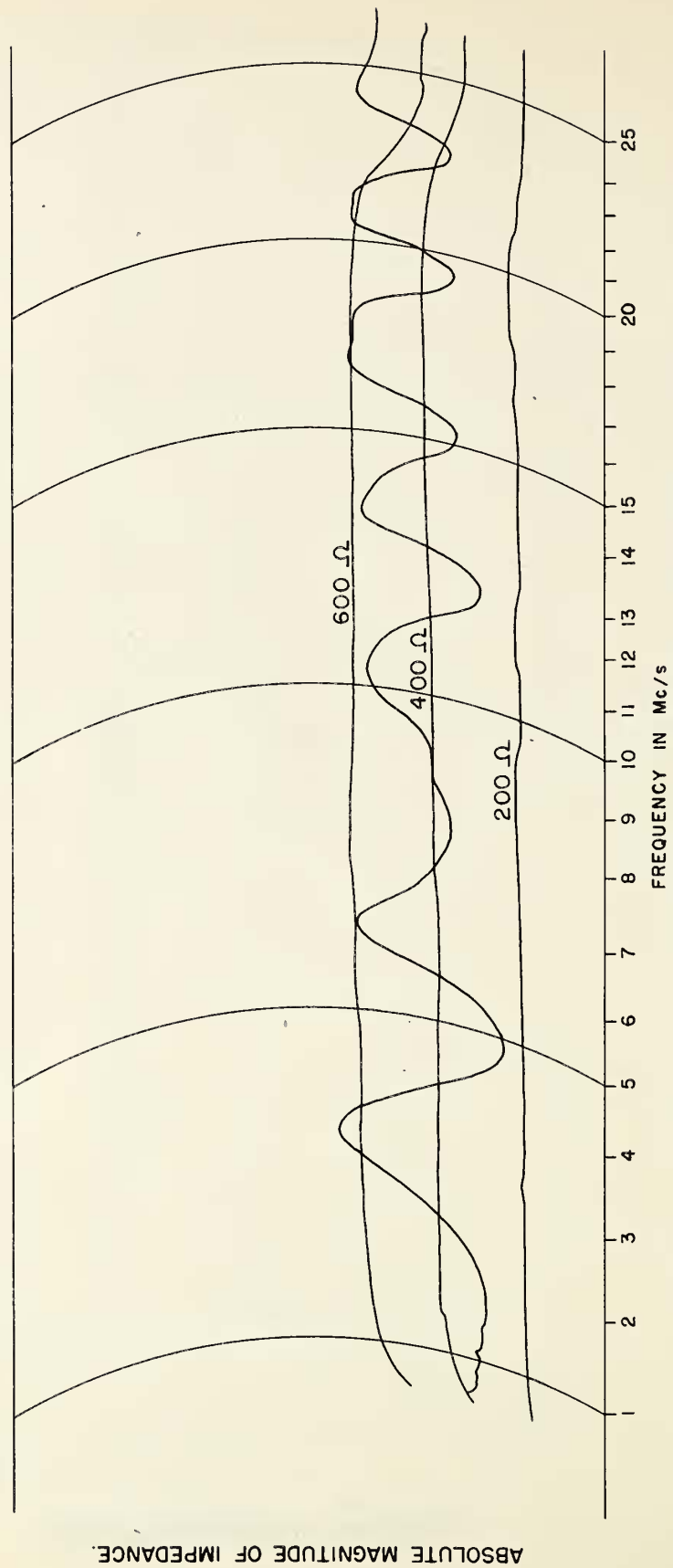

Fig. 8A CONSTRUCTION OF W ANTENNA AND ASSOCIATED TRANSMISSION LINE SYSTEM.



ABSOLUTE MAGNITUDE OF IMPEDANCE.

Fig. 8B. IMPEDANCE OF TRANSMISSION LINE SYSTEM USED WITH W ANTENNA.
800 OHM LINES TERMINATED WITH 800 OHM RESISTORS.



ABSOLUTE MAGNITUDE OF IMPEDANCE.

Fig. 8C. IMPEDANCE OF W ANTENNA FOR OPTIMUM TERMINATION OF 1000 OHMS.

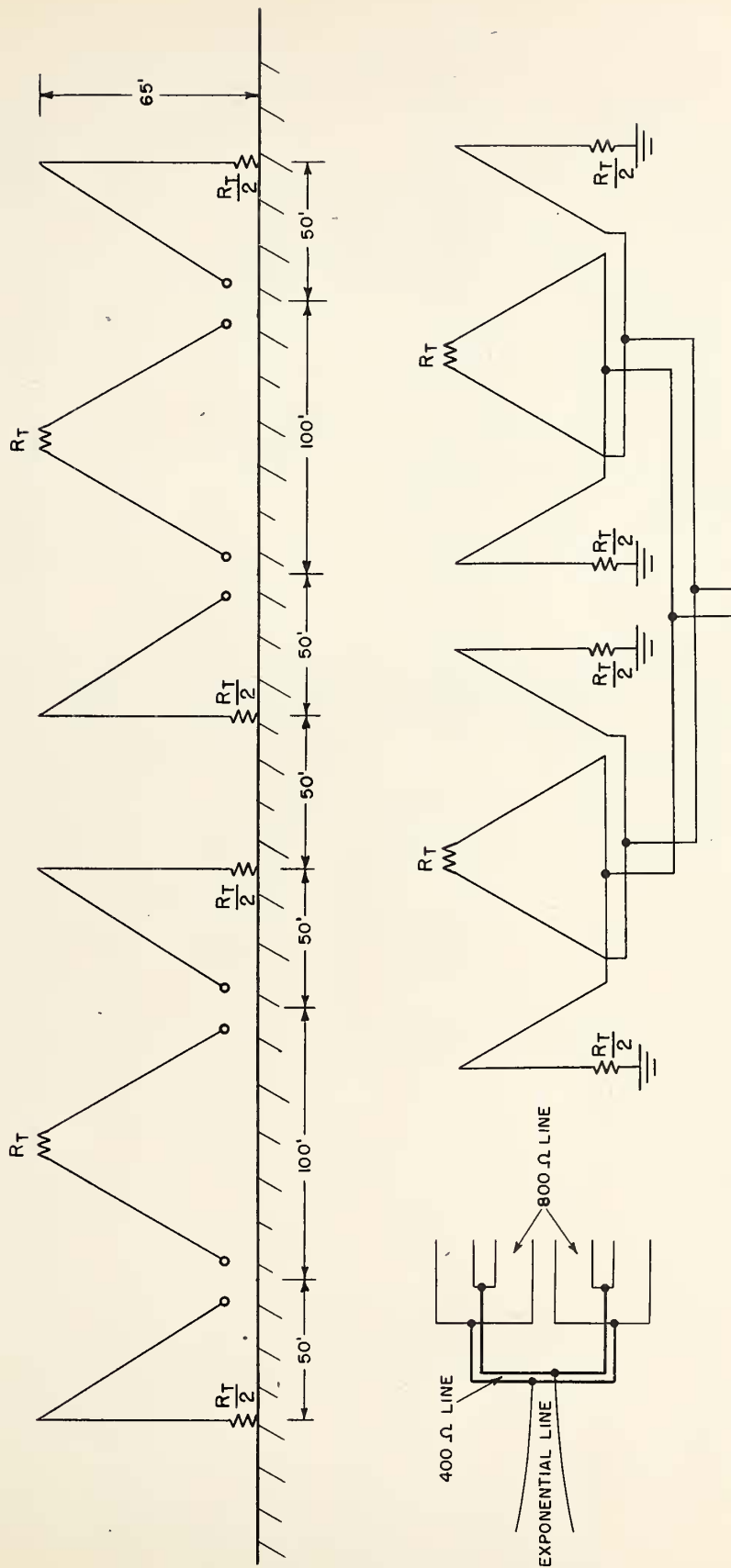

Fig. 9A CONSTRUCTION OF DOUBLE W ANTENNA AND ASSOCIATED TRANSMISSION LINE SYSTEM.

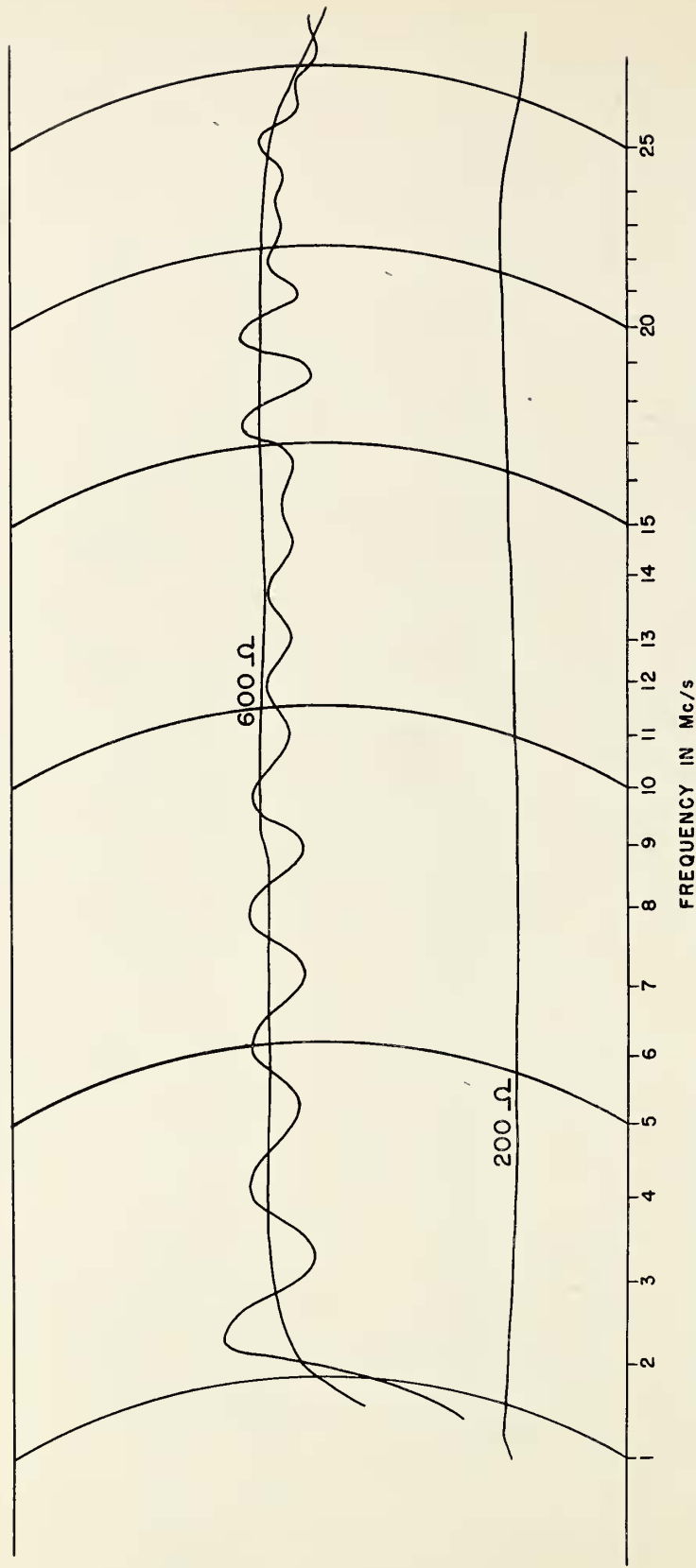
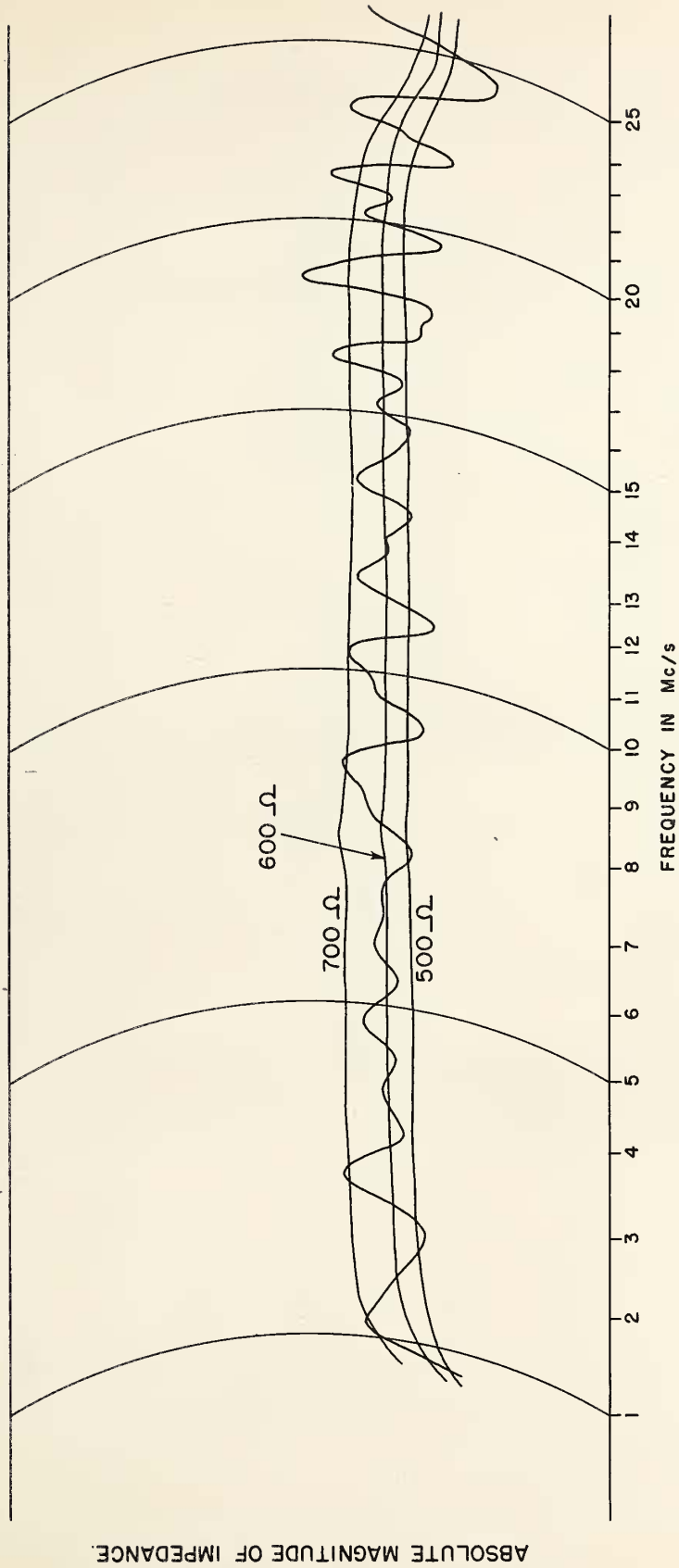

Fig. 9B: IMPEDANCE OF EXPONENTIAL TRANSMISSION LINE. LINE TERMINATED WITH 200 OHM RESISTOR.

ABSOLUTE MAGNITUDE OF IMPEDANCE.



ABSOLUTE MAGNITUDE OF IMPEDANCE

Fig. 9C. IMPEDANCE OF ENTIRE TRANSMISSION LINE SYSTEM USED WITH DOUBLE W ANTENNA.
800 OHM LINES TERMINATED WITH 800 OHM RESISTORS.

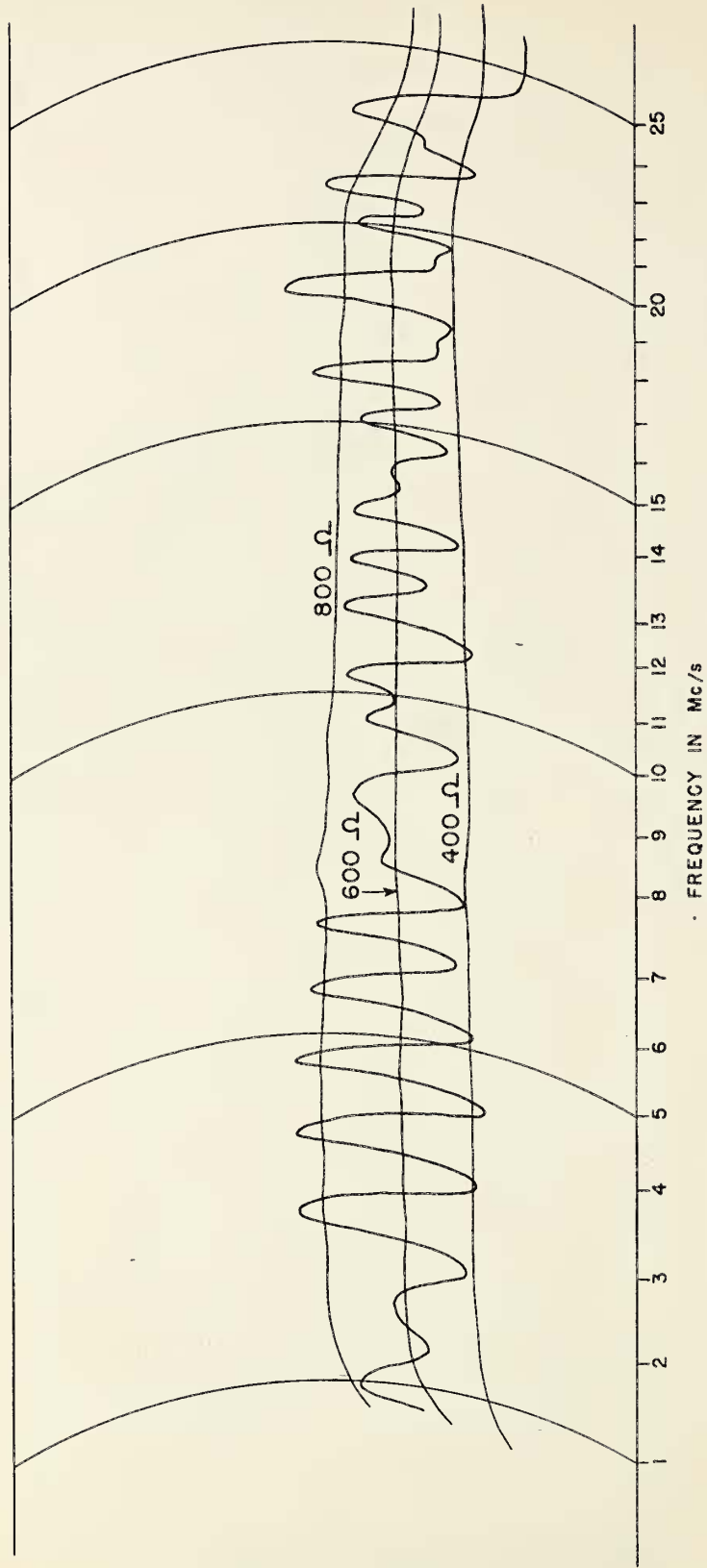

Fig. 9D. IMPEDANCE OF DOUBLE W ANTENNA FOR OPTIMUM TERMINATION OF 1000 OHMS.

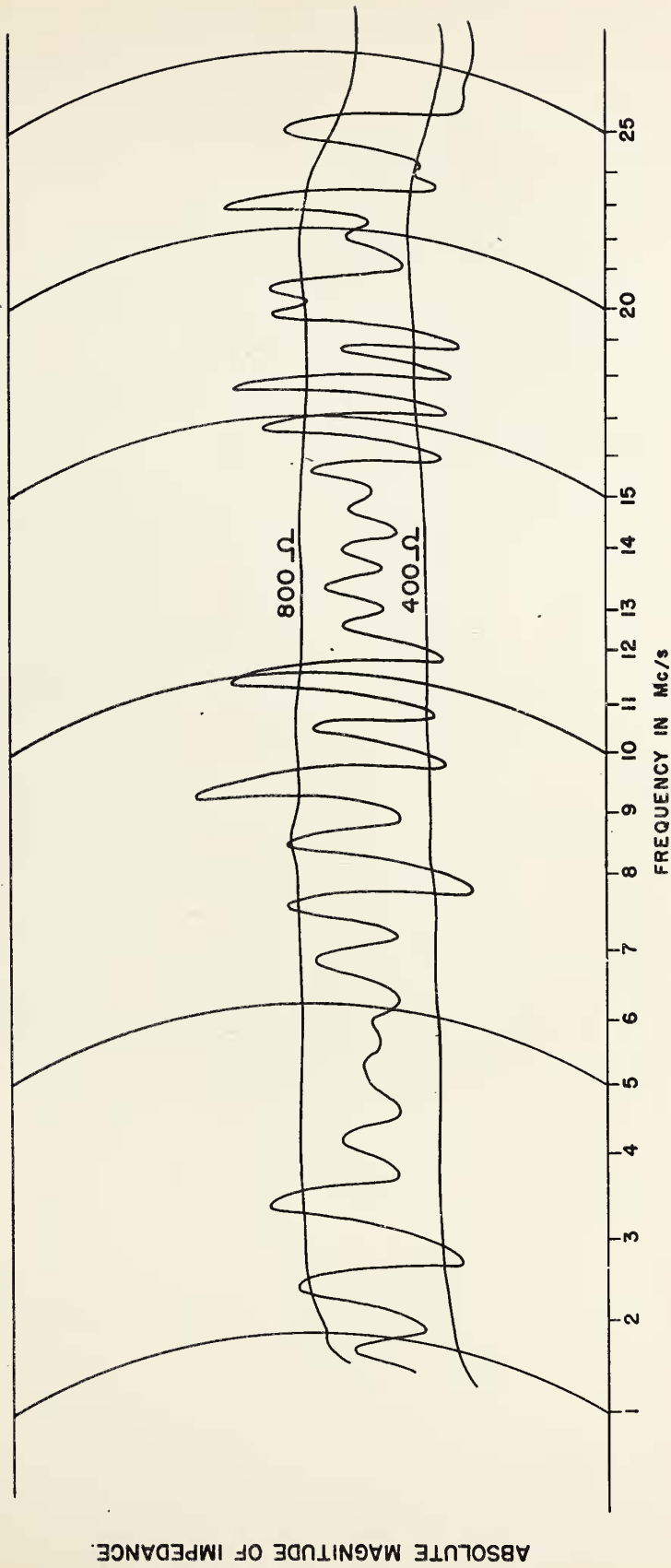

Fig. 9E. IMPEDANCE OF PARALLEL WIRE DOUBLE W ANTENNA.

