

April/May 2003
Issue No. 82

Radio Bygones

£3.25
ISSN 0956-974X

The
Torn.E.b
German
Portable
Battery
Receiver

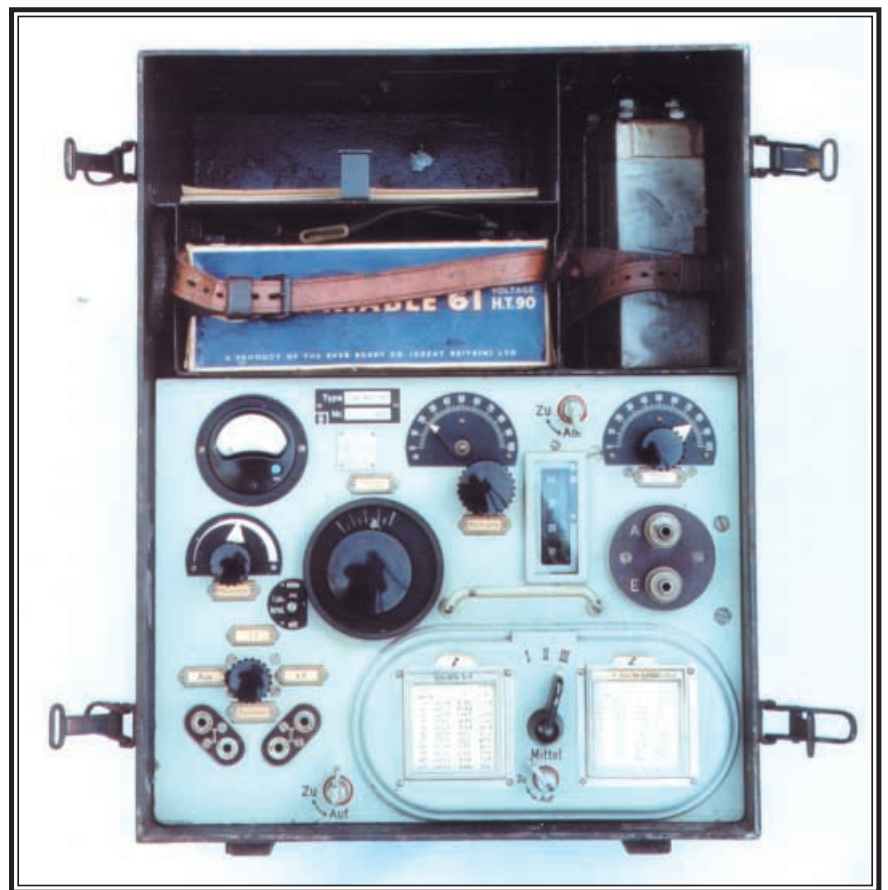

The Marconi Exhibition at Sandford Mill, Chelmsford
Restoring A Goblin S25 'Time Spot' Receiver
A Wobbulator Unit – Constructional project

The Torn.E.b

The German Portable Battery Receiver Type 24b-305

by R. T. Walker, G4PRI

I first became acquainted with the Torn.E.b after the end of the German occupation of the Channel Islands. During the occupation, it had become an offence to possess a radio and most domestic sets had been confiscated. Listening was still carried out on secret crystal sets and hidden, under floor, receivers! In 1945 the family pointed out to me that neighbours nearby had acquired a German field radio receiver which worked very well – had I not better go and look for something similar. Diligent searching unearthed a Torn.E.b (with battery box) and, with the aid of a transformer and speaker the household was back on air!

Most Elegant

It was my humble opinion that the German Torn.E.b receiver was probably the most elegant TRF set ever made, if not the most elegant set overall. However, Arthur Bauer (PA0AOB) and Dick Rollema (PA0SE) have been at pains to point out to me that the Lorenz Lo 6K 39 was probably the most elegant TRF set. I also had to agree with them that “the most elegant overall” was a title to be bestowed on the E52 series of receivers. The E52 series did not appear until 1943 so, I will nominate the Torn E.b/24b-305 as the most elegant pre 1940 TRF receiver!

The Telefunken Torn.E.b /24b-305 (Spez 976 Bs) receiver was the end product of a series of Telefunken ‘portable’ receivers developed mainly for field use from the late 1920s onwards. They were intended for use both as a general purpose field receiver and as an accompanying receiver for a number of transmitters of the type normally found installed in signals trucks. The receiver frequency coverage is from 100kHz to 6670kHz.

The earliest version was designed by Telefunken in the late 1920s as Spez 276 Bs and this was revamped in the early 1930s as Tornister Empfänger (portable receiver) Spez 445 Bs. By later standards it could be described as clumsy. Not unlike the National HRO, it employed plug-in coil units (three of them marked Kurz, Mittel and Lang) to cover the frequency range (see cover photo). The circuit employed four triode valves type RE 074 powered from a 90 volt battery and a 4.8 volt alkaline accumulator (type NC10). Radio, batteries and accessories were all in one case – quite a load for the signalman! With the development of the military general purpose two volt filament pentode valve (RV2 P800) the set was redesigned and split into two cases, one for the radio and one for the batteries and accessories. If necessary, the two cases could be clipped together.



Torn.E.b with Battery Box including Vibrator EW.b

The plug-in coil system was dispensed with and replaced by an integral rotating coil turret. Trials with this equipment pointed to a need for some ergonomic improvements and some simplification of controls and other slight changes resulted in a more ‘user friendly’ front panel. The rectangular power supply plug and socket were replaced by a circular five pin connector which became standard for much field equipment. Thus, in 1936/37 the Telefunken Torn.E.b Spez 976 Bs was accepted for Wehrmacht use as the Torn.E.b/24b-305 (also known outside Germany as the AE95).

Advantages

The TRF receiver had a number of advantages, in the field, over the superhet (at least over the early superhets). It did not suffer from cross modulation nor did it have oscillators that re-radiated (e.g. HRO). However, sensitivity and selectivity depended considerably on the quality of the reaction circuitry.

Tornister-Empfänger Torn.E.b /24 b-305

Gesamtschaltbild

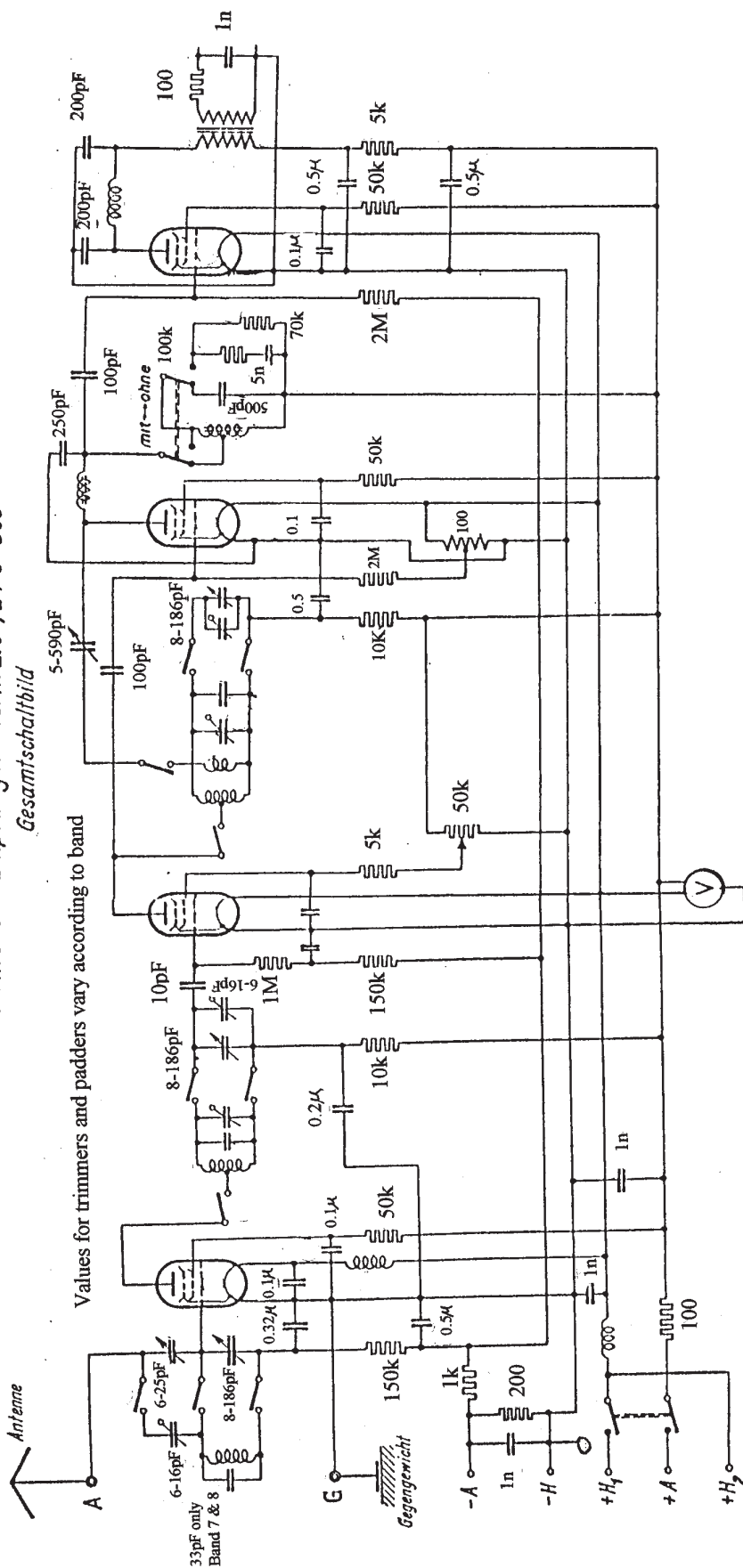

Fig. 1. The Torn.E.b basic circuit diagram

Telefunken engineers paid great attention to the mechanical aspects of the tuning systems and employed superbly made anti-backlash gearing. This ensured not only very fine adjustment of the reaction condenser but, in addition, the capability to return to the exact setting after changing back from another frequency band. The Torn.E.b had been designed essentially as a CW receiver and a 900Hz filter (on the circuit diagram following the detector) could be brought in by activating the Tonsieb switch. General audio quality for speech and music, though acceptable, was not the primary requirement. Post war, a number of amateurs improved the audio quality by adding an external stage of amplification combined with a speaker (a 6V6 or 6F6 valve was used), I never felt that this extra stage was necessary.

The Torn.E.b employed the relatively new multipurpose pentode RV2 P800. These two volt filament valves could be used in a variety of configurations. The receiver had two RF stages, a regenerative detector stage and a low frequency or audio output stage. All stages used the same valve type (see circuit diagram Fig.1) – very useful in the field as only one type of spare need be carried! Perhaps the most outstanding feature was the evolution from plug-in coils to a superb multi-range coil turret covering the frequency range 100kHz to 6670kHz in eight separate sections, easily switched by turning the centre knob on the front panel. A coil turret removed from a Torn.E.b is shown overleaf.

Accessories

As mentioned earlier, the receiver was designed essentially for field use and as an accompanying receiver for a number of transmitters. Accessories were therefore designed to ensure that the set could be operated not only by footslogging signalmen but also in wireless trucks and armoured trains (anyone who has watched the BBC documentary on the Kursk battle might have noticed the signaller, on the armoured train, tuning up his Torn.E.b). The basic equipment consisted of the set itself in an airtight metal case which could be clipped to an identical size of box containing a two volt accumulator (2B38) and a standard 90 volt HT battery. The box also contained two pairs of high

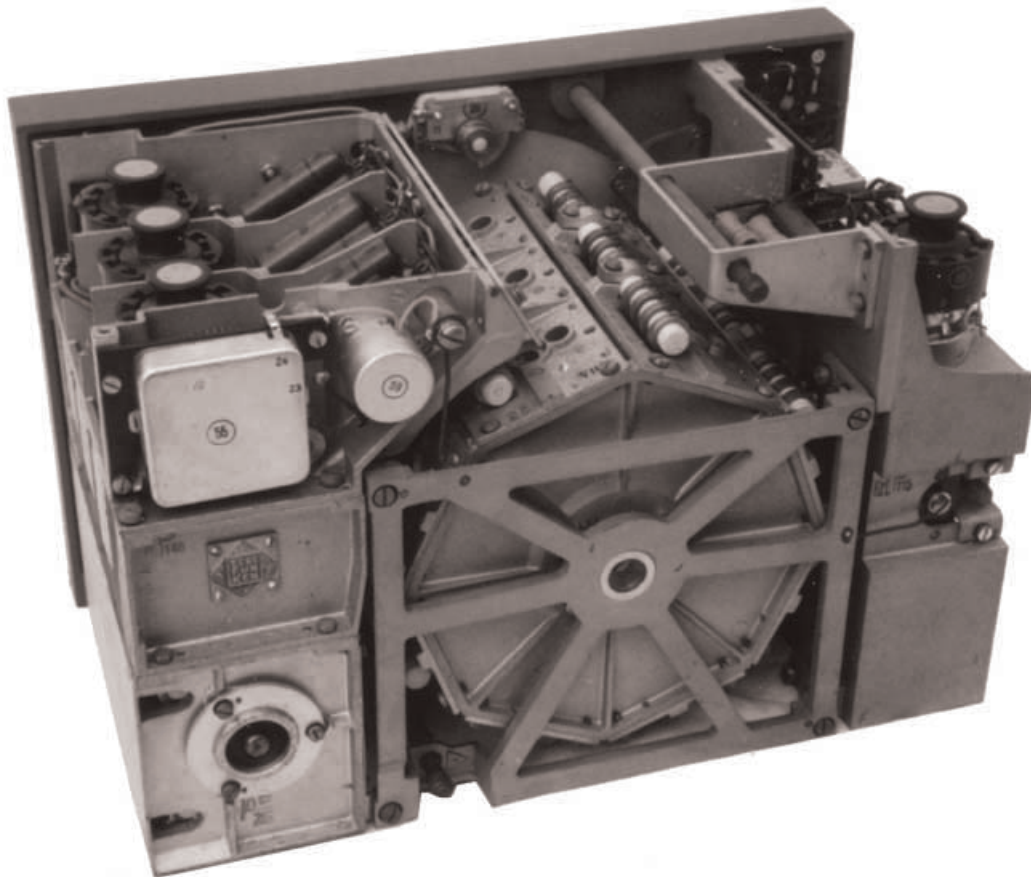

Torn.E.b Rear View

impedance headphones (Dfh.a) and instruction manuals. A small door in the lid of the accessories box could be opened to feed out the power cable.

To facilitate saving of HT batteries, the standard 90 volt battery could be substituted with a vibrator pack (EW.b) which generated 90 volts from the two volt lead/acid accumulator. An additional accessory for field use was an aerial kit in a shoulder slung canvas case. (This aerial pack was given to me in 1945 as being for the Torn.E.b though there has been some difference of opinion in recent times as to whether or not it really was part of the Torn.E.b set up.) Where the set was to be used in vehicles it was normally mounted on an anti-vibration mounting and power supplied from the vehicle's batteries via a vibrator pack type EW.c (Empfänger Wechselrichter c). In wireless trucks the receive antenna was normally built into the roof.

Later Sets

Sets manufactured in the late 1930's were fitted with a voltmeter on the front panel by which both HT and LT could be checked. These sets when withdrawn from their cases exhibited an aluminium screen covering the working parts. Swedish ball-races were fitted to the tuning condenser shaft, anti-backlash gearing was standard and a cast aluminium Telefunken logo was screwed to the rear panel – see photo.

The chassis was formed from diecast magnesium/aluminium alloy sections bolted to the diecast front panel. The diecasting system had been perfected by the Mahle company. The

type label on models made in 1937/38 contained the full designation Torn.E.b/24b-305 plus the serial number and year of manufacture but on models from 1939 onwards the serial number plate was without the 24b-305 designation. The Torn.E.bs were painted in a number of colours depending on the service and even the theatre of war. Army sets were normally standard field grey, with airforce sets the very dark anthracite colour. However, in the desert, such as North Africa, sets tended to be a brown sandy colour. Torn.E.b's produced in 1944/45 were painted a light ground-yellow colour known in Germany as 'Einheitstarnfarbe Europa' which was the standardized camouflage colour for European use.

In the early 1940s manufacturing quality was maintained but some modifications began to creep in. Sets began to appear in 1942 without the voltmeter – the hole for the voltmeter being covered with a small aluminium plate! Whether this was due to a shortage of voltmeters or a whim of production is not clear but the voltmeter was a useful check on the state of the power supplies. The full aluminium screen was also replaced by two smaller screens, one covering the RF and detector stages and the other covering the output stage.

By 1944 screening had been discarded altogether! One other change which was notable occurred with the front panel. Early models had front plate labelling in the form of neatly printed aluminium labels screwed to the face. Later models began to appear with the labelling as an integral part of the diecasting – a sort of embossing. This was sometimes quite difficult to see. By late 1944, the quality of Torn.E.bs reflected the deteriorating state of industry in beleaguered

Germany. The original diecast alloy had been replaced by a poor quality Zinc based alloy resulting in the set weight increasing by 50%! No ball-races were fitted to the tuning condensers and anti-backlash gearing had been replaced by trapped plate mechanisms so that the essential fine adjustment of the reaction condenser was completely lost. Even the aluminium valveholders were being thrown together from punched wrapped sheet (in some cases steel) rather than from drawn aluminium tube.

Manufacturers

I have to thank Werner Thote (DL1VHF) for allowing me access to his excellent research work on manufacturing locations. Knowing the serial number has allowed me to pinpoint the location of manufacture of a number of Torn.E.bs. Early sets made in 1937/38/39 were exclusively manufactured by Telefunken but after these years production was also farmed out to other manufactures. For some sets, manufactured in 1944/45, Werner has been able to pinpoint the converted furniture factory making the outer cases!

Modified Sets

Unhappily, down the years, I have come across a number of Torn.E.bs which have been subjected to a variety of modifications. In one case alterations had been made to the coil turret to convert the set to receive amateur bands only. In other cases the RV2 P800 valves had been substituted with DF91s or, in one case, the set had been modified to run from RV12 P2000 valves, thus requiring a 12 volt LT source and various other circuit modifications. This set was not restorable to its original state without a great deal of careful work (and a source of original parts)! Yet another set had modifications made to sections 5, 6, 7 and 8 of the coil turret to cover the twenty, forty, and eighty metre amateur bands!

For unmodified Torn.E.bs which are not working at their best or do not appear to be receiving any signals, the usual checks applicable to fifty to sixty years old sets should be carried out e.g. valves, capacitors etc. One component should be first on the list for checking and that is component No. 59. This is the choke in the anode lead of the detector valve and is to be found under a small aluminium cover next to the reaction condenser. After a number of years these are prone to fail so no signal gets through to the audio stage. This choke, when dismantled, is quite delicate in nature and should be handled with care. Spares are not available but

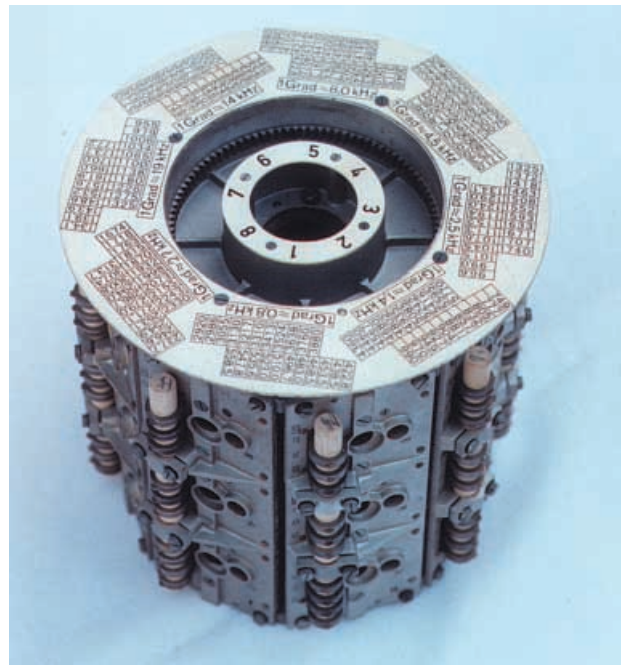

Torn.E.b Coil Turret

there is a firm who will rewind the original ceramic former (s.a.e. to me via the *RB* editorial office for further details).

Acknowledgements: Thanks are due to Werner Thote, DL1VHF, for data on manufacturing locations and to Rod Burman, G4RSN, for the loan of an early 1930's set.

Further reading: *Die deutschen Funknachrichtenanlagen bis 1945, Band 2 "Der Zweite Weltkrieg"*. Fritz Trenkle.

German WWII Communications Receivers, CQ August 1980. Dick Rollema, PA0SE.

Wireless for Wehrmacht in Detail. Published by RAK-Frantisek Koran, Prague.

Communication Equipment of the German Army. Charles L. Barger. Paladin Press. (In this book, no mention is made of the vibrator EW.b. Furthermore, in the 1943 Torn.E.b illustrated, I suspect that the meter has been installed post war!)

Final Note! For anyone fortunate enough to have both radio and battery box, in addition to headphones etc, the battery box should contain copies of handbooks H.Dv D915/1 and D915/5 for army sets or a copy of *Vorläufige Beschreibung und Bedienungsvorschrift des Tornier Empfänger Torn.E.b/24b-305* for Luftwaffe sets. **RB**

VVT TRANSFORMERS

All types of transformers for all types of circuits
including specialist valve units
Transformers for restoration of old radios
Custom design or standard range
High and low voltage

Variable Voltage Technology Ltd
Unit 3, Sheat Manor Farm, Chillerton, Newport, Isle of Wight, PO30 3HP
Tel: 0870 243 0414 Fax: 01983 280593
email: sales@vvt-cowes.freemove.co.uk
www.vvttransformers.co.uk

WILSON VALVES

(PROP JIM FISH G4MH)

Over 60,000 valves stocked, 2000 different types,
for ham radio, audio, military.
Fast service. Send SAE for list

**28 Banks Avenue, Golcar, Huddersfield,
West Yorks HD7 4LZ**

Telephone: 01484 654650/01484 649380
Fax: 01484 655699
e-mail: wilsonv@zoo.co.uk

For vintage radio valves contact: Vintage Valve Supplies,
prop. Roger Walker, on 01484 650725, mobile 07733 283084.
78 Scar Lane, Milnsbridge, Huddersfield, HD7 4LZ