

Instructions for Installation
of
NOISE SUPPRESSOR
COMPONENTS
for
RADIO RECEIVER BC-624-A
PART OF RADIO SET SCR-522-A

NOTE: These instructions are to be glued into the Instruction Book for Radio Set SCR-522-A until such time as a Technical Order covering this modification is issued.

Manufactured by
COLONIAL RADIO CORPORATION

RESTRICTED

This document contains information affecting the National Defense of the United States within the meaning of the Espionage Act, 50 U. S. C., 31 and 32, as amended. Its transmission or the revelation of its contents in any manner to an unauthorized person is prohibited by law.

The information contained in restricted documents and the essential characteristics of restricted material will not be communicated to the public or to the press, but may be given to any person known to be in the service of the United States and to persons of undoubted loyalty and discretion who are cooperating in Government work.

FEBRUARY 7, 1944

TABLE OF CONTENTS

Paragraph	Page
1 General	3
2 List of Material Supplied.....	3
3 Replaceable Parts List	3 & 4
4 Tools Required	5
5 Outline of Changes	5
6 Details of Changes (Including Labeling)	5
7 Resulting Schematic Diagram	5
8 Testing of Changed Receivers.....	6
a. Inspection	6
b. Realignment	6
c. Test for Isolation.....	6
d. Test for Noise Suppression.....	6

ILLUSTRATIONS

Figure 1	Preparation for Installation of Kit Parts
Figure 2	Installation of Kit Parts
Figure 3	Resulting Schematic Diagram

1. GENERAL

- a. This kit of parts when properly installed in BC-624-A Radio Receiver will provide improved reception in the presence of all manner of pulse like interference. The major performance characteristics of the receiver will not be materially changed. The most obvious change in performance will be a reduction of approximately 3 to 1 in the audio output from the detector. This will be apparent to the user in that the volume control must be advanced from the point where it is normally set. For general use the receiver as modified should give reception at distances equal to or greater than before modification.

2. LIST OF MATERIAL SUPPLIED

- | a. Quantity | Description |
|-------------|--|
| 1 | Terminal board and socket assembly including a 12H6 tube |
| 1 | Capacitor and bracket assembly |
| 1 | Envelope containing screws, nuts, solder, resistor (47,000 ohm), stencil, etc. |
| 1 | Installation Instruction |
- b. Extra nuts, screws, lockwashers, and wire are included in case of loss.

3. REPLACEABLE PARTS LIST

- a. Most of the material provided in this kit is also used elsewhere in Radio Set SCR-522-A. Therefore, the material now in existence may be used to service the components in the kit. The following table shows the standard part numbers and the reference numbers indicating where these parts are used in the original equipment. Where a part has a new circuit function, it has been assigned a new reference number. The location of these parts is given in Figure 2.

Reference Number	Quantity	Description	Function	Bendix Part Number	Old Reference Number	British Reference Number	Stock No.
266-2	1	270M ohm Resistor	AVC Filter	A18004-274	266-2	110C/2911	3Z6727-4
275-1	1	470M ohm Resistor	AVC Diode Load	A18004-474	275-1	110C/2917	3Z6747-7
264-2	1	10M ohm Resistor	1/2 of Diode Load	A18004-103	264	110C/2903	3Z6610-50
276-2	1	18M ohm Resistor	1/2 of Diode Load	A18004-183	276	110C/2907	3Z6618-14
271-2	1	82M ohm Resistor	Limiter Bias Filter	A18004-823	271	110C/2920	3Z6682-2
272-2	1	120M ohm Resistor	Limiter Load	A18004-124	272	110C/2904	3Z6712-17
253-3	1	330 ohm Resistor	AVC Diode Bias	A102975-331	253-1	110C/3002	3Z6033-1
254-3	1	6800 ohm Resistor	AVC Diode Bias	A102975-682	254-1	110C/3006	3Z6568-3
279-4	1	47M ohm Resistor	#3 I.F. Screen Resistor	A18004-473	279-1	110C/2916	3Z6647-6
203-3	1	47 uufd mica capacitor	AVC Diode Coupling	C58467-470	203-3	110C/3742	3D9050-41 Note 1
219	1	.001 ufd mica capacitor	Limiter Cathode By-Pass	C56315-102	105-1	110C/25	3DA1-55
206-24	1	.0068 ufd mica capacitor	Audio Coupling	A102967-8	206-1	110C/2994	3DA6-23 Note '2
211-2A*	1	.1 mfd Paper	Limiter Bias Filter	A25096	211-A	110C/1618	3DA100-83
211-2B		.1 mfd Paper			211-B		
211-2C		.1 mfd Paper	2nd I.F. Grid By-Pass		211-C		
	1	12H6 Vacuum Tube	Noise Limiter and AVC Delay				

Note 1: Also obtainable under Stock Nos. 3D9050-41, 3DK9047-7 or 3DK9047-10

Note 2: Also obtainable under Stock Nos. 3DKA6.800-7, 3DKA6.800-9, 3DKA6.800-10, 3DKA6.800-11 or 3DKA6.800-12

*Due to critical procurement problems encountered during the manufacture of this kit some capacitors in this position were used which differ mechanically or in voltage rating from that listed. Where replacement is necessary part No. A25096 should be used.

4. TOOLS REQUIRED

- a. Medium sized screw driver.
- b. Socket wrench. (To fit $\frac{1}{4}$ " Hex nut).
- c. Long nose pliers.
- d. Diagonal wire cutters.
- e. Soldering iron.
- f. Test Equipment IE-12-A or equivalent for intermediate frequency alignment.
- g. Signal Generator I-196-A or buzzer for checking noise suppression.

5. OUTLINE OF CHANGES

- a. The major changes take place in the diode detector circuit where one section of a 12H6 tube has been added to serve as a series noise limiter biased by a portion of the average D.C. voltage developed by the second detector. The other half of this tube holds the A.V.C. bias to substantially zero until the average D.C. voltage developed by the A.V.C. diode exceeds the delay voltage. The automatic volume control voltage is now derived from the primary of the last intermediate frequency transformer. Other changes have been made in the grid circuits of the intermediate frequency amplifiers to reduce cross modulation effects caused by grid current due to high noise voltage pulses.

6. DETAILS OF CHANGES (INCLUDING LABELING)

- a. Refer to Figure 1, Preparation for Installation of Kit Parts. Remove wires, hardware, and parts as indicated. These parts should be retained since some of them will be required in the reassembly operation.
- b. Refer to Figure 2, Installation of Kit Parts. Make the assembly as indicated. Also connect all wires as shown and securely solder them.
- c. Label changed receivers with letter "M" as instructed in Figure 2.

7. RESULTING SCHEMATIC DIAGRAM

- a. The resulting schematic diagram for that portion of the circuit where changes were made is given in Figure 3. In some instances, elements are connected in the circuit but have no useful function. These are identified in the diagram and were retained simply to make the changes easier.

8. TESTING OF CHANGED RECEIVERS

- a. Make careful inspection to determine that proper installation has been effected, that all leads are well soldered, leads properly placed, etc.
- b. It will be necessary to make slight changes in the alignment of the first, second, and third intermediate frequency transformers. The fourth one will require considerable change in adjustment. The primary adjusting screw will usually have to be turned clockwise $1\frac{1}{2}$ turns. The secondary screw will usually require turning counter-clockwise 3 turns. For this realignment the crystal controlled 12 M.C. oscillator of Test Equipment IE-12-A should be used. If this is not available, the oscillator used should be carefully adjusted to 12 M.C. before alignment is attempted. Frequency Meter BC-221-(), Part of SCR-211-(), may be used for this purpose.
- c. For successful operation, there must be good circuit isolation between the diode circuit and the volume control circuit. A test for this may be made by simply removing the 12H6 tube from its socket, when a signal from a signal generator is being used. With a full scale indication on the output meter with the 12H6 in place, the output should go to substantially zero when it is removed.
- d. A test may be made to determine whether there is an appreciable suppression of noise. This may be done by tuning the receiver to a relatively small signal and then turning on some sort of noise generator such as the ignition system of a motor. With a connection made between terminals "T" "T" shown on terminal board, in left hand view of Figure 2, the noise suppression circuit is cut out and considerable interference should be encountered. When this short is removed, the interference should become relatively very low. If Signal Generator I-196-A, part of IE-46-(), is available, it may be used to provide a source of pulse noise in the extreme high frequency end of the band.

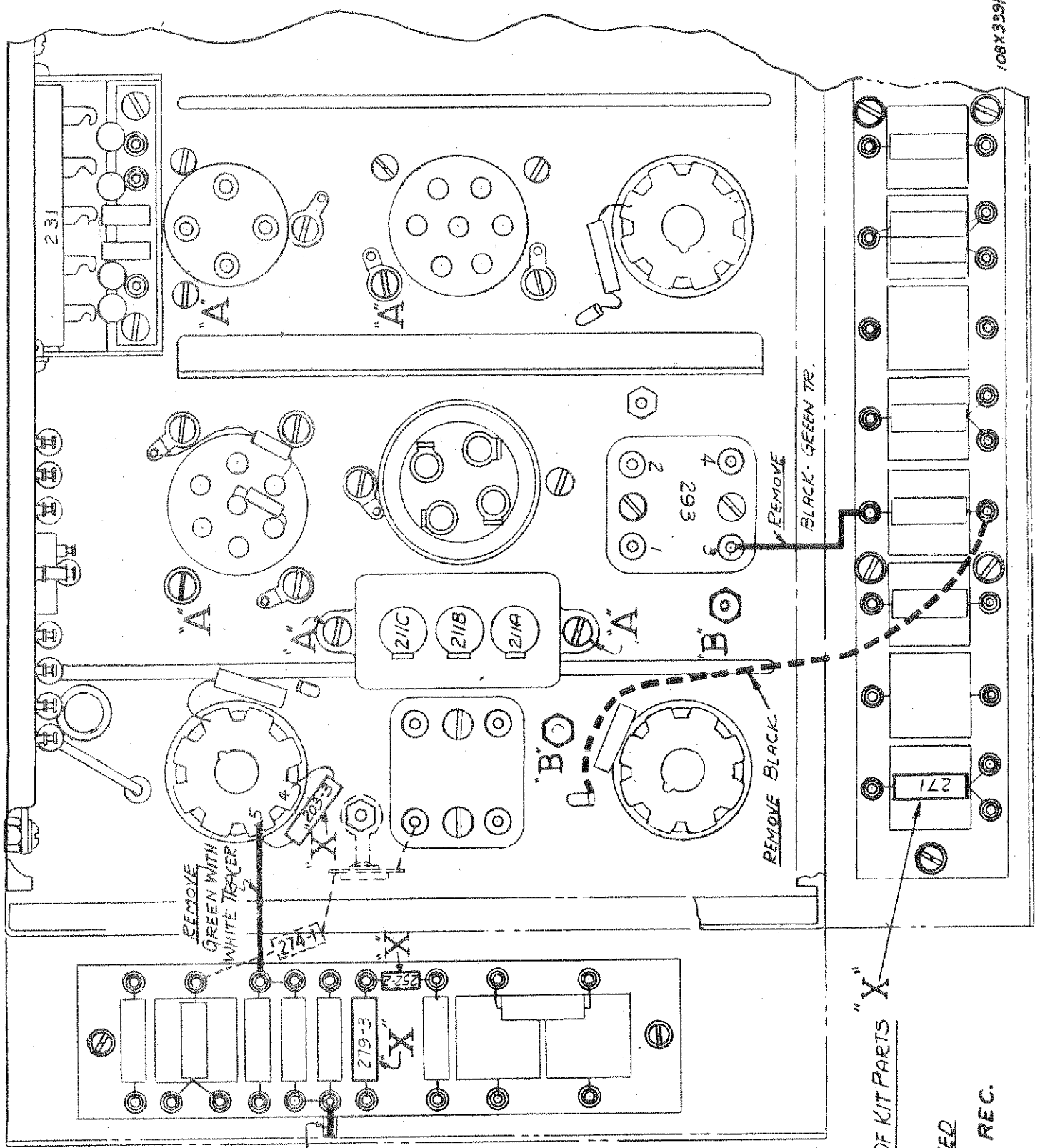

NOTES:

1. Remove Screws and Lockwashers indicated "A". (5 places).
2. Move Capacitor Ref. No. 211A, B, C in direction of Plug Ref. No. 231, without unsoldering any leads.
3. Remove Nuts and Lockwashers indicated "B". (2 places). **REMOVE BARE**
4. Component Removals.
 - A. Remove Capacitor 203-8 and Resistors 252-2; 279-3 and 271 as indicated by "X".
 - B. For original production 279-3 will be Symbol 281. 252-2 will be a jumper. Remove both.
 - C. If Receiver has orange paint spot on tip of Squelch Relay Control #237 (per T.O. 08-5-70) then remove Resistor, symbol 274-1 and supporting Terminal shown dotted.
5. Cut off and remove Leads indicated by solid line (3 places).
6. When black Lead indicated by heavy dotted line is present cut Lead on both ends and remove.

PREPARATION FOR INSTALLATION OF KIT PARTS "X"

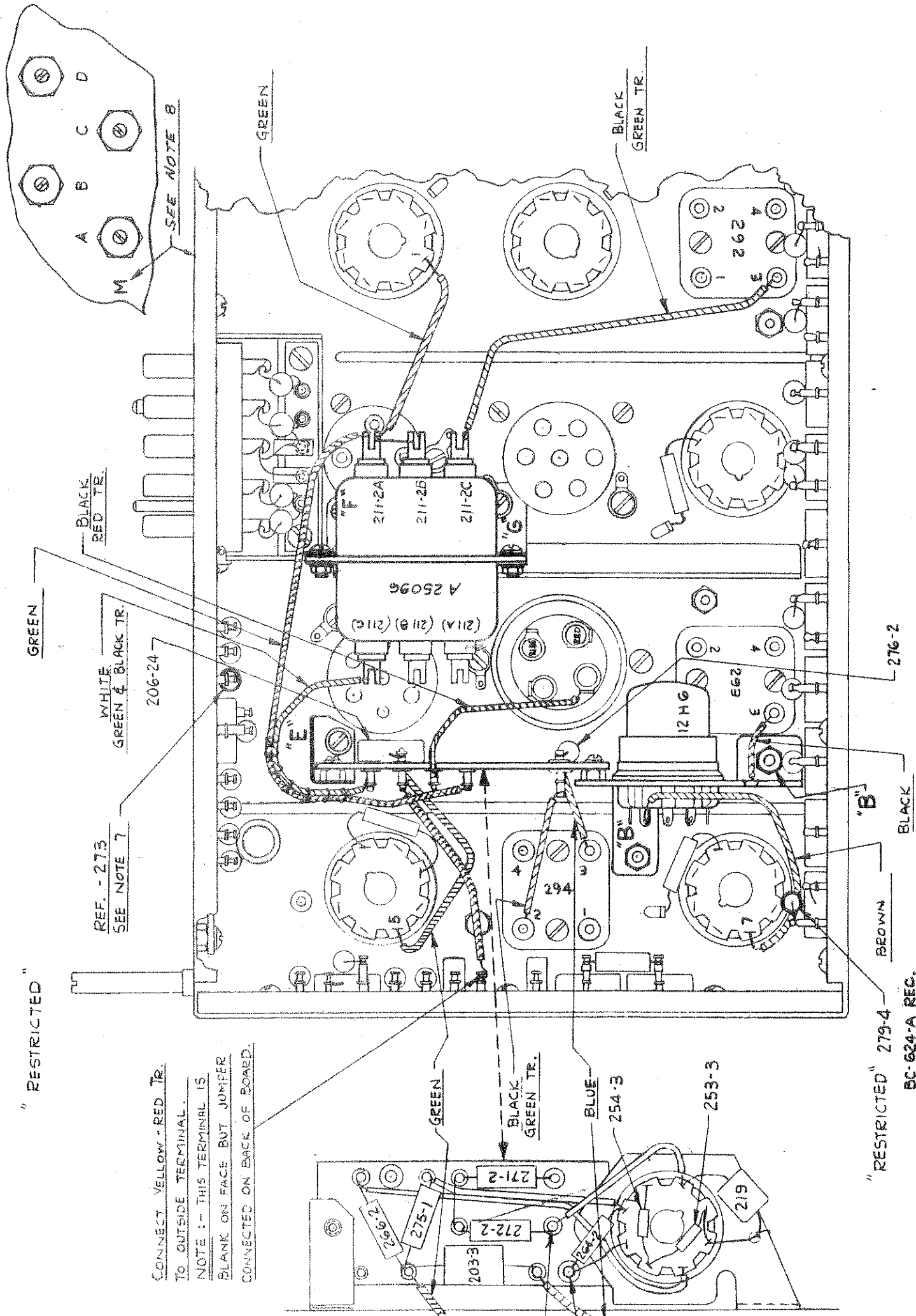

" RESTRICTED "

CONNECT YELLOW - RED TR.
TO OUTSIDE TERMINAL.
NOTE 1 - THIS TERMINAL IS
BLANK ON FACE BUT JUMPER
CONNECTED ON BACK OF BOARD.

" RESTRICTED " 279-4
BROWN
BLACK
276-2

BC-624-A REC.
INSTALLATION OF KIT PARTS

- FIG. # 2 -

NOTES:

1. Fasten Tube and Resistor Board Assembly in position shown. Place leads to 211 A, B and C under this Board. Use Nuts and Lockwashers previously removed as per Fig. 1 in locations "B" and one of the 5/16 Lg. #6-32 Screws and Lockwashers in Location "E", furnished in envelope.
2. Assemble Capacitor Mounting Bracket with Capacitor 211-2 A, B, C in place as shown. Use $\frac{1}{4}$ long #4-40 Screw and Lockwasher in location "F", and 5/16 long #6-32 Screw and Lockwasher in Position "G". Be sure to replace Ground Lug at Position "G". The necessary parts are furnished.
3. Assemble Capacitor A25096, Symbol 211 removed as in Note 2 Fig. 1 on back of Condenser Bracket. Use #6-32 Nuts and Lockwashers furnished. All Leads are usually long enough to allow placing Capacitor A25096, Symbol 211 on the Bracket without wiring change. In some cases the black-red tracer lead from Ref. 211 to Ref. 212 may be too short, a spare wire is supplied.
4. Connect and solder 11 free ends of Leads as shown.
5. Connect 279-4 in place of 271.
6. Check tightness of Screws Mounting new Board.
7. Where reference 273 appears remove and connect Jumper across terminals formerly used.
8. Mark Chassis from Stencil supplied using black paint in two places. (1) On Chassis at right side of Signal Corps Nameplate in line with Nomenclature BC-624-A so that it will read, BC-624-AM. (2) On Chassis just to the left of the "A" Channel core adjustment as shown.

RESTRICTED

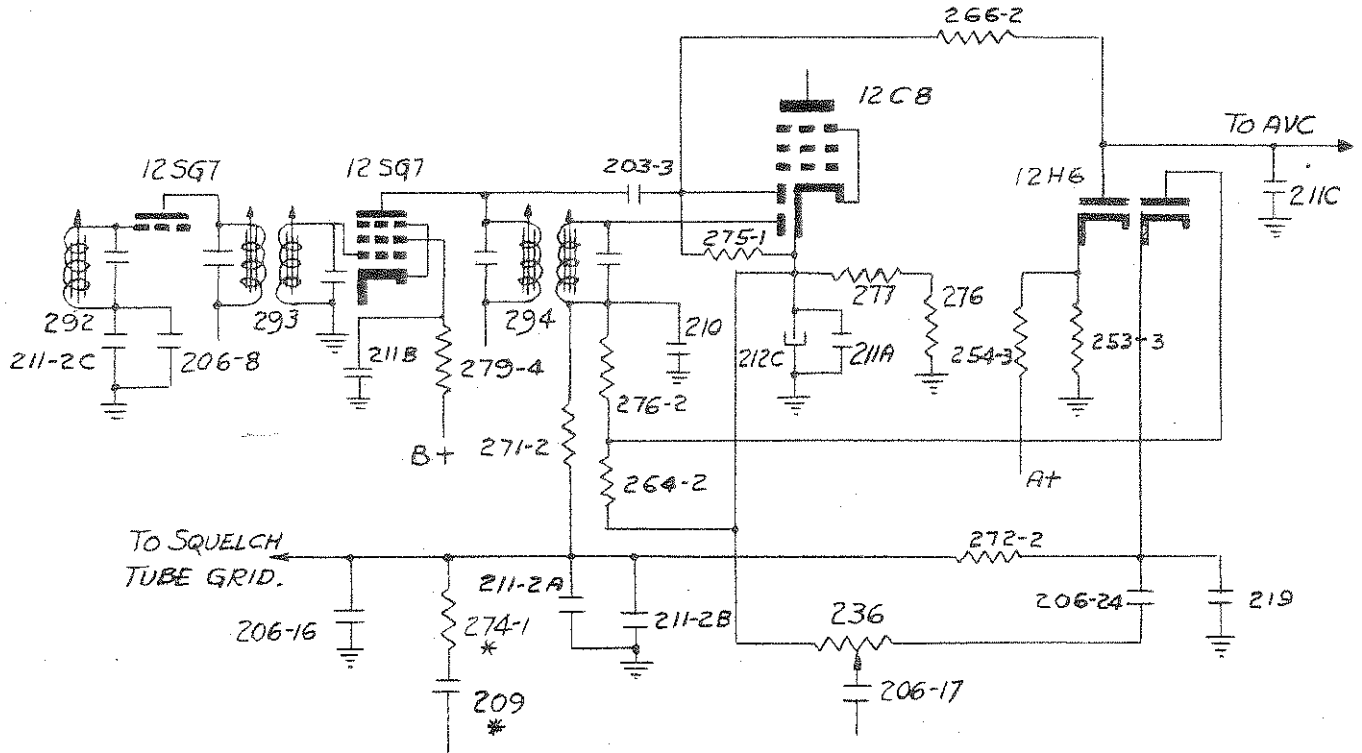

* THESE PARTS HAVE NO FUNCTION
BUT ARE LEFT CONNECTED AS
SHOWN TO SIMPLIFY CONVERSION.

RESULTING SCHEMATIC DIAGRAM

RESTRICTED

SCR-522-A NOISE SUPPRESSION KIT

- FIG 3 -

108X3393