



MODEL A-2515

Solid State

5 BAND
AM/CW/SSB AMATEUR/SWL
COMMUNICATIONS RECEIVER

INSTALLATION AND OPERATING MANUAL

SPECIFICATIONS

| | |
|-------------------------|--|
| FREQUENCY COVERAGE: | .15 to .40 MHz .55 to 1.6 MHz 1.6 to 4.8 MHz 4.8 to 14.5 MHz 10.5 to 30 MHz |
| RECEIVING MODES: | AM, CW, and Single Sideband. |
| ANTENNA INPUT: | 50 to 400 ohms unbalanced. |
| SENSITIVITY: | 2 μ V for 10 dB. S/N 3.2 μ V for 10 dB. S/N Broadcast Band |
| SELECTIVITY: | ± 1.5 kHz at -6 dB. |
| INTERMEDIATE FREQUENCY: | 455 kHz |
| BFO FREQUENCY: | 455 kHz ± 3.5 kHz |
| AUDIO POWER OUTPUT: | 1.3 watts |
| OUTPUT IMPEDANCE: | 4 or 8 ohms |
| POWER REQUIREMENT: | 110 to 120 V AC 50/60 Hz. or 12 V DC Negative Ground |
| POWER CONSUMPTION: | 10 watts |
| DIMENSIONS: | 7 $\frac{5}{8}$ " H. \times 15" W. \times 10" D. |
| WEIGHT: | 17.8 lbs. |
| TRANSISTOR COMPLEMENT: | Q401 40603 (TA7150) RF Amplifier (FET) Q402 40603 (TA7150) Mixer (FET) Q403 2SC381R Local Oscillator Q101 2SC454 First IF Amplifier Q102 2SC454 Second IF Amplifier Q103 2SC454 Third IF Amplifier Q104 2SC454 Beat Frequency Oscillator Q201 2SC281 First Audio Amplifier Q202 2SC281 Second Audio Amplifier Q203, 204 2SB473 Audio Power Output |
| DIODE COMPLEMENT: | D401, 402 1N60 Protection device D101 1N60 AM Detector & AGC Rectifier D102 Silicon Diode Automatic Noise Limiter D103, 104 1N60 AGC Rectifiers D105, 106 1N60 CW-SSB Detectors D301, 302 Silicon Diodes AC Rectifiers D305 Zener Diode Voltage Regulator |

GENERAL DESCRIPTION

The ALLIED Model A-2515 is a sensitive superheterodyne communications receiver which covers the popular .55 MHz to 30 MHz portion of the radio frequency spectrum plus additional coverage of the low frequencies from 150 kHz to 400 kHz. The receiver is designed to receive CW (code), AM (voice) and SSB signals in the covered bands.

The receiver employs tuned RF and first mixer stages to give maximum sensitivity and a high signal-to-noise ratio, while three IF stages plus four 455 kHz mechanical filters provide a high degree of selectivity. A balanced detector operating in conjunction with a BFO is employed for CW and Single Sideband operation, while a separate diode detector is used for AM reception.

For main tuning, the receiver employs a calibrated slide rule dial. A special bandspread tuning dial, calibrated for amateur bands, provides for extremely accurate, easy tuning. A logging scale of 0 to 100 is also provided for shortwave listeners use.

The receiver operates from a dual power source, of 110-120 volts, 50/60 Hz AC or 12 V DC. On AC, a 1 ampere fuse in the primary of the power transformer is used for protection of the equipment. The B + power supply consists of four silicon diodes in the full-wave rectifier circuits. For DC operation a separate 1 Amp. fuse is utilized.

The antenna input can be connected to a coaxial type of lead-in and it is designed for use with unbalanced lines of 50 — 400 ohms impedance. Outputs for 4 or 8 ohm speakers are provided at the rear of the receiver. A front panel jack provides for headphone listening. Inserting the headphones into the jack automatically silences any speaker connected to the 8 ohm output terminal. A speaker connected to the 4 ohm output terminal will continue to play.

Other receiver features include an Antenna Trimmer control, an "S" meter calibrated in "S" units from 1 to 9 and in decibels above S9, an RF Gain Control, Automatic Noise Limiter on AM, and a full-time AVC circuit.

UNPACKING INSTRUCTIONS

After unpacking the receiver, carefully check for possible damage which may have occurred in transit. Should any signs of

damage be apparent (tubes broken, case dented, etc.), notify the store from which the receiver was purchased. If the unit was shipped to you, also file a claim with the carrier.

Check to see if a jumper plug is in the packing case or plugged into the remote socket on the rear chassis of the A-2515. **THIS PLUG MUST BE INSERTED INTO THE REMOTE SOCKET FOR NORMAL RECEIVER OPERATION.**

INSTALLATION

(See Figure 5)

● POWER SOURCE

This receiver is designed to operate from 110 to 120 volts, 50/60 Hz AC and 12 volts DC.

Attempting to operate the A-2515 receiver from any other power source will result in serious damage to the receiver's circuitry.

● SPEAKER CONNECTION

A three terminal strip marked OUTPUT is provided at the rear of the receiver for speaker connections. Any PM (permanent magnet) speaker with either 4 or 8 ohm impedance can be used. Simply connect one lead to the ground terminal marked "0" and the other lead to the terminal that corresponds to the speaker impedance. The output of the A-2515 is sufficient to drive a 4 - 12 inch PM speaker adequately.

● HEADPHONES

A standard phone jack is provided on the front panel of the receiver for headphone reception. (See Figure 6). Low impedance (8 to 16 ohms) headphones are recommended for optimum results. Use of headphone impedance up to 2000 ohms will provide satisfactory operation. Insertion of a phono plug into the front panel jack automatically disconnects any speaker attached to the 8 ohm output terminal. If operation of both headphone and speaker is desired, the headphones should be wired to the OUTPUT terminal on the rear apron of the receiver or use a 4 ohm speaker connected to the 4 ohm terminal. In this case it will be important to keep the volume control low so as to not exceed the headphone's audio power limit.

● ANTENNAS

The A-2515 receiver is designed to operate from any antenna with a transmission line impedance of 50 to 400 ohms. The antenna input circuit is of the unbalanced type and is ideally suited for use with a coaxial transmission line.

(a) SINGLE WIRE ANTENNA

The single wire or inverted "L" type of antenna will provide satisfactory performance over the entire tuning range. Simply connect one end of the antenna wire to "ANT". For good reception, the antenna wire should be 50 to 100 feet long and placed as high as possible (see Fig. 1). Generally, this type of antenna provides maximum pick-up at right angles to its entire length. This should be borne in mind when installing the antenna. In some locations, reception may be improved by connecting a ground wire from the G N D terminal to a cold water-pipe or outside ground rod. For protection against lightning, a lightning arrester should be included in any outdoor antenna system.

(b) DOUBLET ANTENNA

A doublet antenna will give excellent results, especially on amateur bands. A 75 ohm balanced transmission line should be used (as shown in Fig. 2). Since the doublet antenna provides optimum performance only at a given frequency, it should be cut

to the length for the most often used band of frequencies. The overall length of a doublet antenna can be determined by using the following formula:

$$L \text{ (Length in feet)} = \frac{468}{\text{Frequency MHz}}$$

Since the doublet antenna displays directional properties broad-side to its length, it should be oriented in such a manner that maximum signal pickup can be realized.

(c) OTHER ANTENNA SYSTEMS

More elaborate antenna systems may be installed to provide better performance. Information on a number of different types can be obtained by referring to the Radio Amateur's Handbook or the A.R.R.L. Antenna Book, both published by the American Radio Relay League, West Hartford, Conn.

● FUSE

If replacement of the fuse becomes necessary it is located at the top side of the chassis. First remove the chassis enclosure by unscrewing the four bolts holding it in place. Then remove the fuse holder cover and replace the fuse. Be sure replacements are always made with a similar type 1 ampere rated fuse for AC operation and a 1 ampere rated fuse for DC operation.

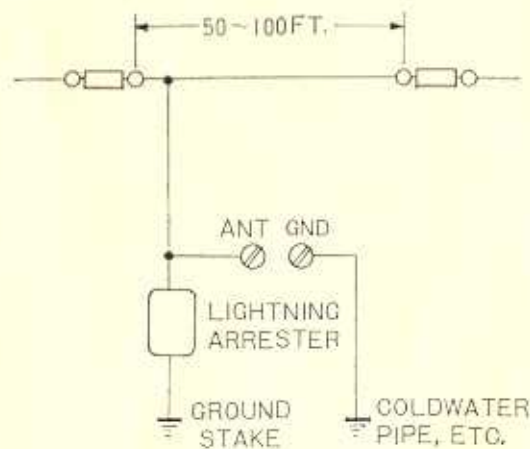

Figure 1

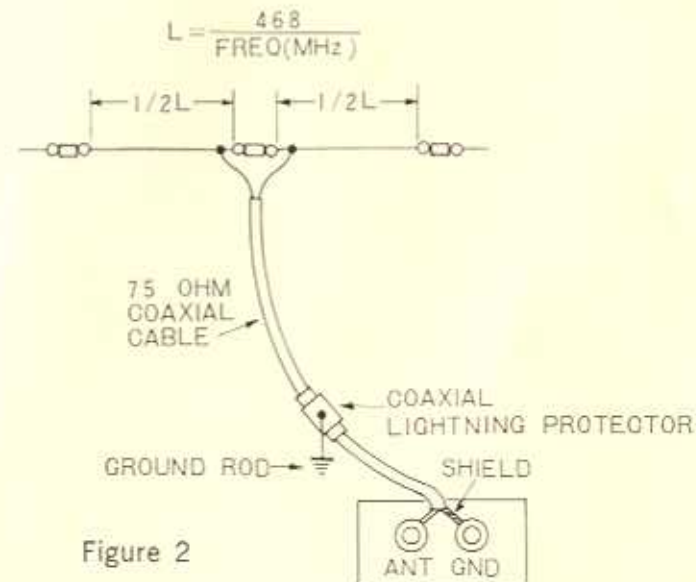
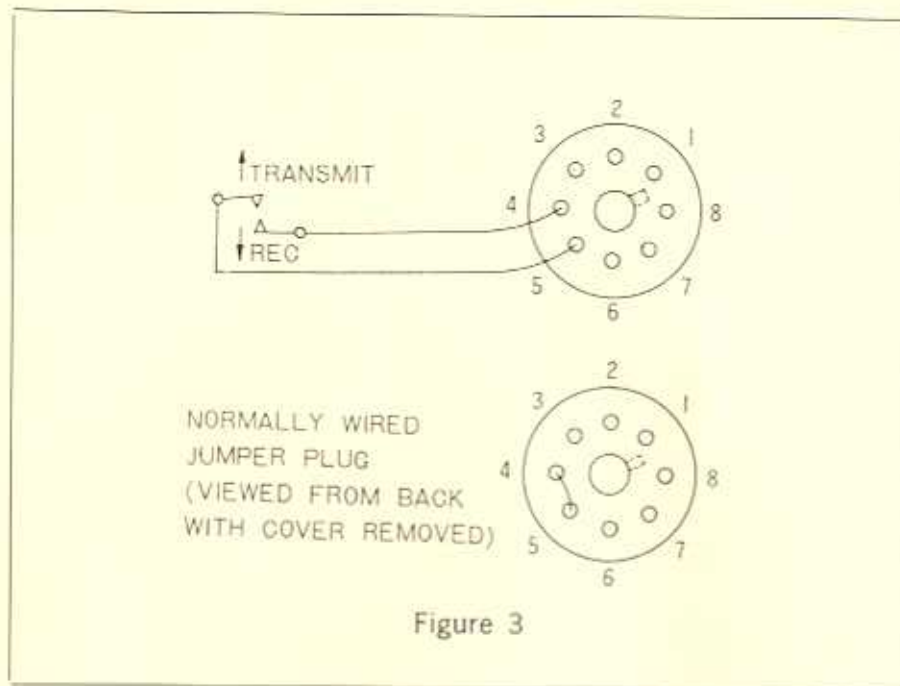

Figure 2



● AUXILIARY CONTROL SOCKET (REMOTE)

A socket on the back of the A-2515 receiver allows simultaneous control of this receiver with a transmitter. An external switching device can be constructed so that the receiver will become inoperative during periods of transmission. Some coax relays have contacts for this purpose. The external switch is attached to the 8-pin jumper plug so that pins 4 and 5 will be connected when signal reception is desired. The re-wired plug is then inserted into the 8-pin socket. In this manner, signal reception will be instantaneous, as B + will be applied when the switch is closed. For normal operation, the unmodified jumper plug (with pins 4 and 5 shorted) must be used. Pins 4 and 5 of this plug are shorted to provide B + to the receiver's circuitry. To disable the receiver under these conditions, set the FUNCTION switch to the SEND position. In this position, the B + is cut off providing you with stand-by operation. Returning the switch to the AM, AM ANL, or CW-SSB positions will provide instantaneous operation.

● DC OPERATION

For DC operation, remove the DC Power Plug and connect the supply leads as shown in the diagram below. Be sure to observe polarity. Failure to do so will severely damage your receiver and will not be covered during the warranty period. Now reinsert this plug. Locate the AC-DC Power Selector Switch at the rear of the chassis. After removing the white cover plate, switch it to the DC side. Replace the white cover plate, screwing it in place this time on the opposite side.

DESCRIPTION OF CONTROLS

(See Figure 6)

1. FUNCTION

This switch selects the mode of operation for the receiver. Each position selects the following mode:

POWER OFF — In this position, the receiver is inoperative. In all other positions (except "Send"), B + is applied to all transistors.

AM — This position provides for normal reception of amplitude modulated signals using diode detection.

AM ANL — This position provides for reception of amplitude modulated signals under conditions of excessive external interference. ANL stands for Automatic Noise Limiter.

SEND — In this position, the receiver's B + voltage is cut off. This position is sometimes called "stand-by".

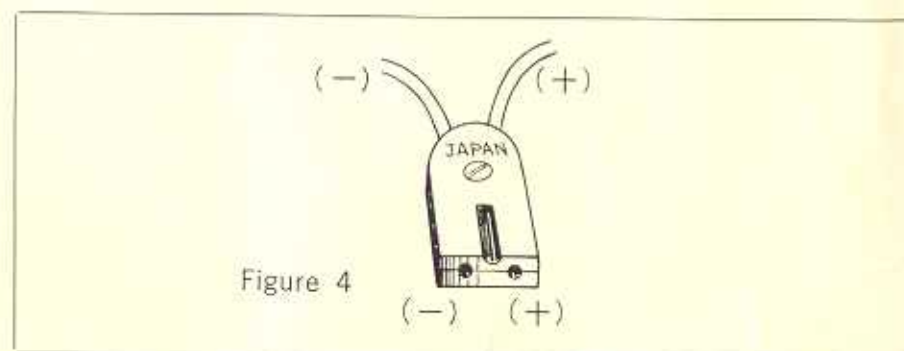

CW-SSB — This position is used for CW (continuous wave or code) and SSB (Single side-band) operation. A balanced detector is used for this type of reception.

2. AF GAIN

This is a variable resistor in the audio circuit which provides control of the audio input to this stage and thus permits adjustment of the audio output level.

3. BFO

This control varies the frequency of the Beat Frequency Oscillator to provide a change in pitch of the signal that is heard in the CW or SSB mode of operation. Movement of the control counter-clockwise selects lower sideband operation and movement clockwise selects upper sideband operation.

4. BAND SEL

This switch selects the desired band of operation. This switch is marked off into the following positions:

- 0.15 — 0.40 (aircraft or marine beacons, weather, etc.)
- 0.55 — 1.6 (standard AM broadcast)
- 1.6 — 4.8 (short-wave and Amateur bands)
- 4.8 — 14.5 (short-wave and Amateur bands)
- 10.5 — 30.0 (short-wave and Amateur bands)

The numbers represent frequency coverage in megahertz.

5. RF-GAIN

This is a variable resistor in the antenna circuit. As a general rule, the RF-Gain control is set to maximum.

6. ANT TRIM

The ANT TRIM control acts as a compensating capacitor to permit optimum matching of the receiver to the antenna at all frequencies. Initially, the control should be set to its mid-position. The control should be always adjusted for maximum background noise as heard through the loudspeaker or headphones. On strong signals, a change will be noted on the "S" meter. Each setting will be good only over a limited range of frequencies. The trimmer should therefore always be readjusted after tuning to the general area where the expected signal is to be found.

7. BANDSPREAD AND MAIN TUNING

These flywheel operated controls vary the receiving frequency by changing the capacity in the RF and local oscillator circuitry.

The main tuning and bandspread dials are calibrated in megahertz and contain special markings to simplify tuning. The major amateur radio bands are contained in the 1.6 to 4.8, 14.5 and 10.5 to 30.00 megahertz scales. The location of each amateur band is indicated by heavy white scale lines on the main tuning dial. The circled letter or letters which appear with each band indicate the bandspread scale to be used. Calibration of the main tuning scales is correct when the bandspread pointer is set at 100 on the LOGGING SCALE.

Bandspreading on the amateur bands is carried out in the following manner: Set the bandspread pointer initially to 100 and the main tuning pointer directly over the circled letter for the band to be tuned. In some cases the band is split between two such letters. For example, B1 and B2 together cover the range of 7.0 to 7.3 MHz — B1 from 7.0 to 7.145, B2 from 7.145 to 7.3 MHz. The calibrated bandspread scale which is used is indicated to the right and left-hand side. Thus, if the main tuning pointer is set over B1, the bandspread scale in use is the one marked B1, the fourth one down. Tuning is then accomplished solely with the BANDSPREAD control.

Short-wave bandspreading, for other than amateur bands, is accomplished by setting the bandspread pointer at 100 on the Logging Scale and the main tuning pointer at the high end of the short-wave band to be tuned. Rotate the bandspread control to tune over the band. Moving the bandspread pointer towards "O" on the logging scale subtracts from the frequency indicated on the main tuning scale. Logging of short-wave stations is possible by noting the readings on both the Main Tuning and Logging Scales.

8. S-METER READINGS

The S-Meter provides a means of measuring the relative strength of incoming AM signals. Relative readings are only correct when the RF-GAIN control is fully clockwise. Measurements are read in "S" units from 1 to 9 and in decibels above S9 from 0 to 40 dB.

A ZERO ADJ control at the rear of the receiver is provided for zeroing the S-Meter electrically. This adjustment is made with the antenna disconnected and the terminals shorted. The RF-GAIN control set at maximum. (see Fig. 5)

Figure 5

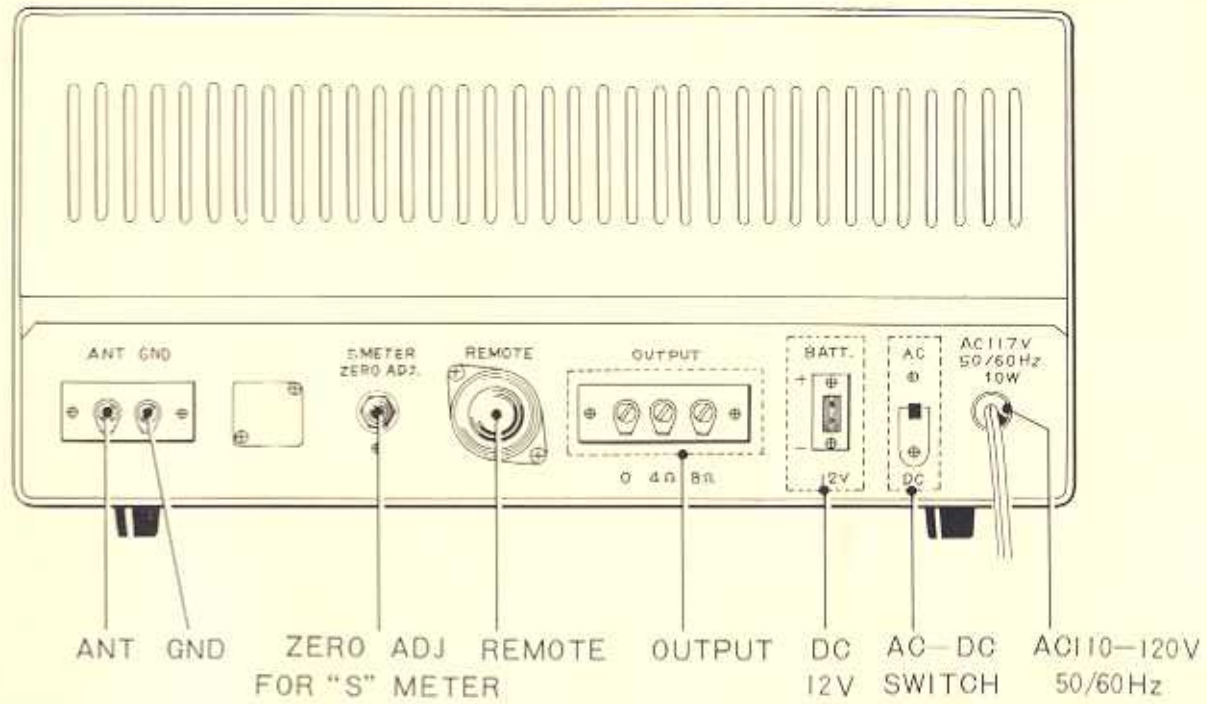

Figure 6

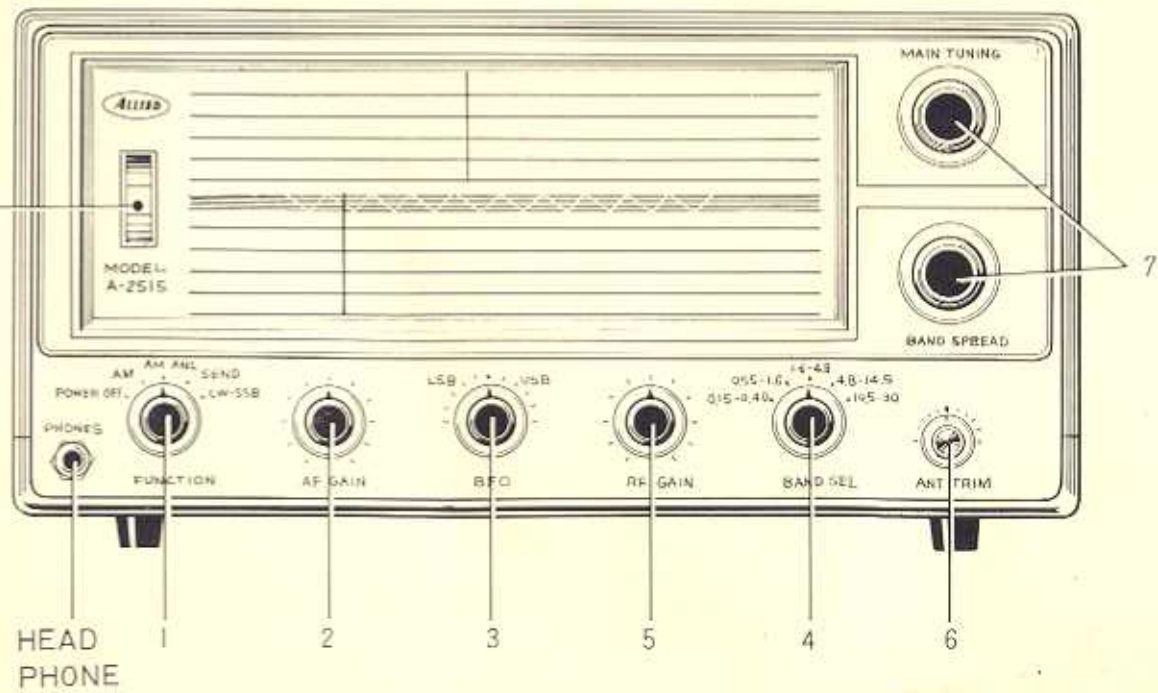

TABLE 1

| CONTROL | AM SETTING | CW SETTING | SSB SETTING |
|-------------|--------------------------------|--------------------------------|--------------------------------|
| Function | AM or ANL | CW-SSB | CW-SSB |
| AF GAIN | Adjust for desired audio level | Adjust for desired audio level | Adjust for desired audio level |
| BFO | Inoperative | Mid-Position | Mid-Position |
| Band Sel | Set for desired range | Set for desired range | Set for desired range |
| RF-Gain | Maximum | Maximum | Maximum |
| ANT TRIM | 12 o'clock position | 12 o'clock position | 12 o'clock position |
| Bandspread | Set to 100 on Logging Scale | Set to 100 on Logging Scale | Set to 100 on Logging Scale |
| Main Tuning | Set to desired frequency | Set to desired frequency | Set to desired frequency |

OPERATING INSTRUCTIONS

Table 1 indicates the initial settings of the various controls for each type of operation. Therefore, the degree of strength and clarity with which signal will be received will depend upon proper readjustment of the various controls.

● AM OPERATION

For the reception of broadcast stations, shortwave listening, etc., place all controls in the positions indicated in the Initial Control Settings chart. Tune in a station, using Main and Bandspread tuning controls as indicated in the section under "TUNING". Adjust ANT TRIM for highest "S" meter reading. This antenna control setting is satisfactory while operating over a limited frequency range. If excessive spurious noises such as those caused by auto ignition make reception difficult, place the FUNCTION switch in the AM ANL position. The automatic noise limiter should be used only when necessary, since it tends to reduce the overall efficiency of the receiver.

● CW OPERATION

The control settings required for the reception of code signals are indicated in the chart. Tune signal to zero beat. The BFO control should then be adjusted on either side of the center dot for desired pitch.

● SINGLE SIDEBAND OPERATION

Control settings for sideband reception are virtually the same as for CW. Note, however, that markings on either side of the BFO control are provided to permit selection of either the upper or lower sideband, as necessary. The sideband that must be selected will depend upon the band in use. As indicated in the sideband selection chart (TABLE 2), the lower sideband is usually required for SSB reception on 80 and 40 meters, the upper sideband for SSB reception on 20, 15 and 10 meters.

● SINGLE SIDEBAND TUNING

The initial settings of controls for SSB reception is essentially

the same as for CW (see chart). The BFO frequency, however, is used in this case for carrier reinsertion. Tune station in with BANDSPREAD control and then adjust the BFO control in the direction required (either upper or lower) until clarity of speech is obtained. Slight readjustment of the BANDSPREAD may be necessary to provide best audio quality.

TABLE 2

| METERS | FREQUENCY | SIDEBAND USED |
|--------|------------------|---------------|
| 80 | 3.5 to 4.0 MHz | Lower |
| 40 | 7.0 to 7.5 MHz | Lower |
| 20 | 14.0 to 14.5 MHz | Upper |
| 15 | 21.0 to 21.5 MHz | Upper |
| 10 | 28.0 to 29.7 MHz | Upper |

TABLE 3

| SHORTWAVE BROADCAST BAND* | FREQUENCY (MHz) | LISTENING TIME |
|---------------------------|-----------------|----------------------------------|
| 60 meter band | 4.80 to 5.00 | Winter nights |
| 49 meter band | 5.90 to 6.40 | Winter nights |
| 41 meter band | 7.10 to 7.40 | Winter nights |
| 31 meter band | 9.20 to 9.70 | Nights, all year |
| 25 meter band | 11.60 to 12.00 | Nights, all year |
| 19 meter band | 15.10 to 15.45 | Days, all year and Summer nights |
| 16 meter band | 17.70 to 17.90 | Days, all year and Summer nights |
| 13 meter band | 21.45 to 21.75 | Days, all year |
| 11 meter band | 25.40 to 26.10 | Days, all year |

* These are separate and distinct from the Amateur Shortwave bands which operate over different groups of frequencies.

On the short wave frequencies are to be found radio stations transmitting from all over the world. Many of these stations provide English-language broadcasts. The frequencies on which most shortwave broadcast stations operate are found in the two upper bands of your receiver. The majority of shortwave broadcast stations operate within certain internationally assigned groups of frequencies, or "bands". For your convenience, a list of the shortwave bands which offer best reception has been provided (TABLE 3). Since shortwave reception varies with the time of day, season of the year and with weather conditions, recommended listening times have also been shown along with each shortwave band.

SERVICE AND ALIGNMENT

DIAL CORD STRINGING

Set main or bandspread tuning capacitor as indicated. In both cases tie one end of the dial cord to the spring at the starting point

leaving approximately 4 inches of cord free at this point. Restring in the direction indicated with moderate tension. Make final tie to free end of cord left at beginning of this procedure. Apply firm tension before tying. Cut away excess cord.

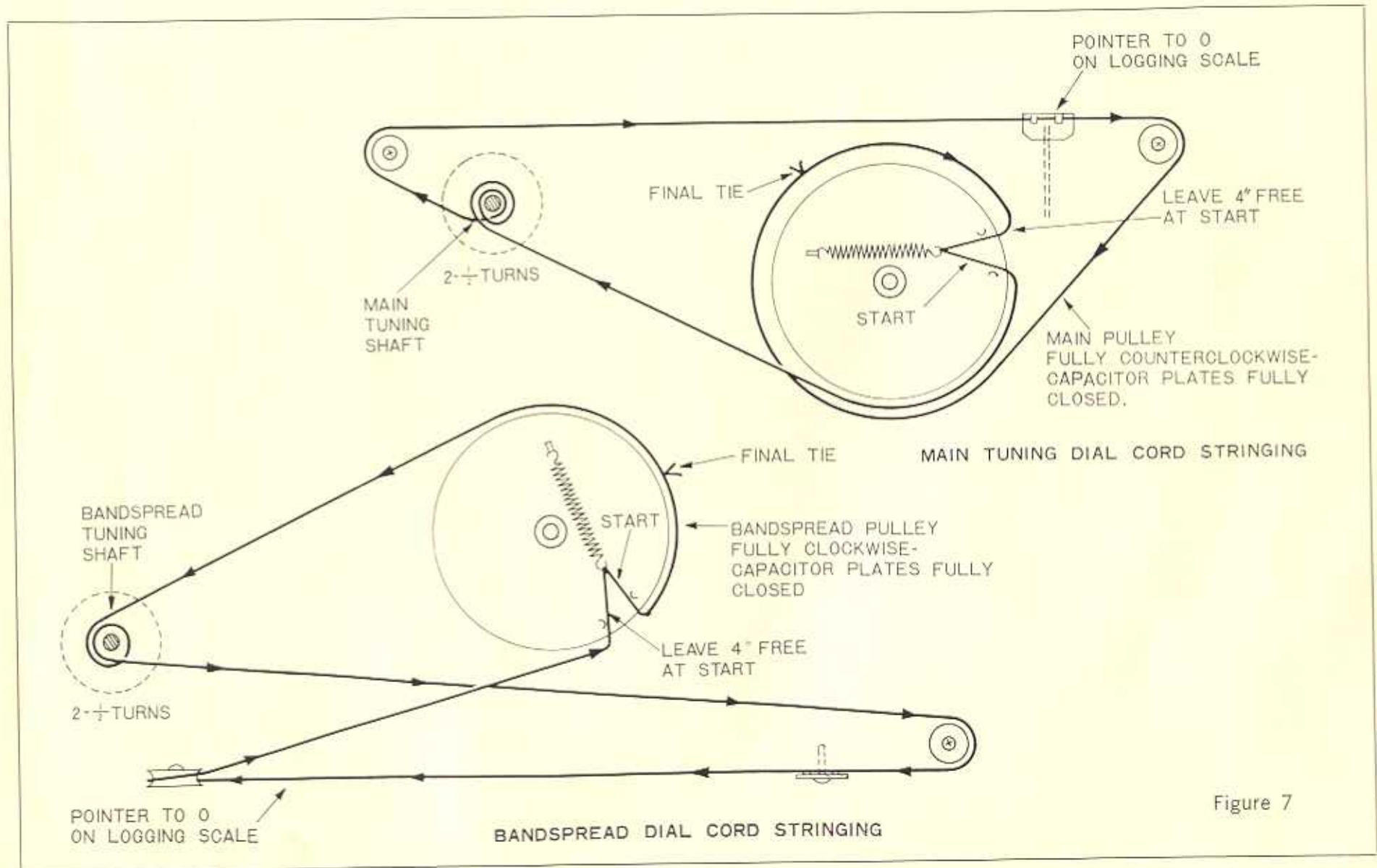

Figure 7

BLOCK DIAGRAM

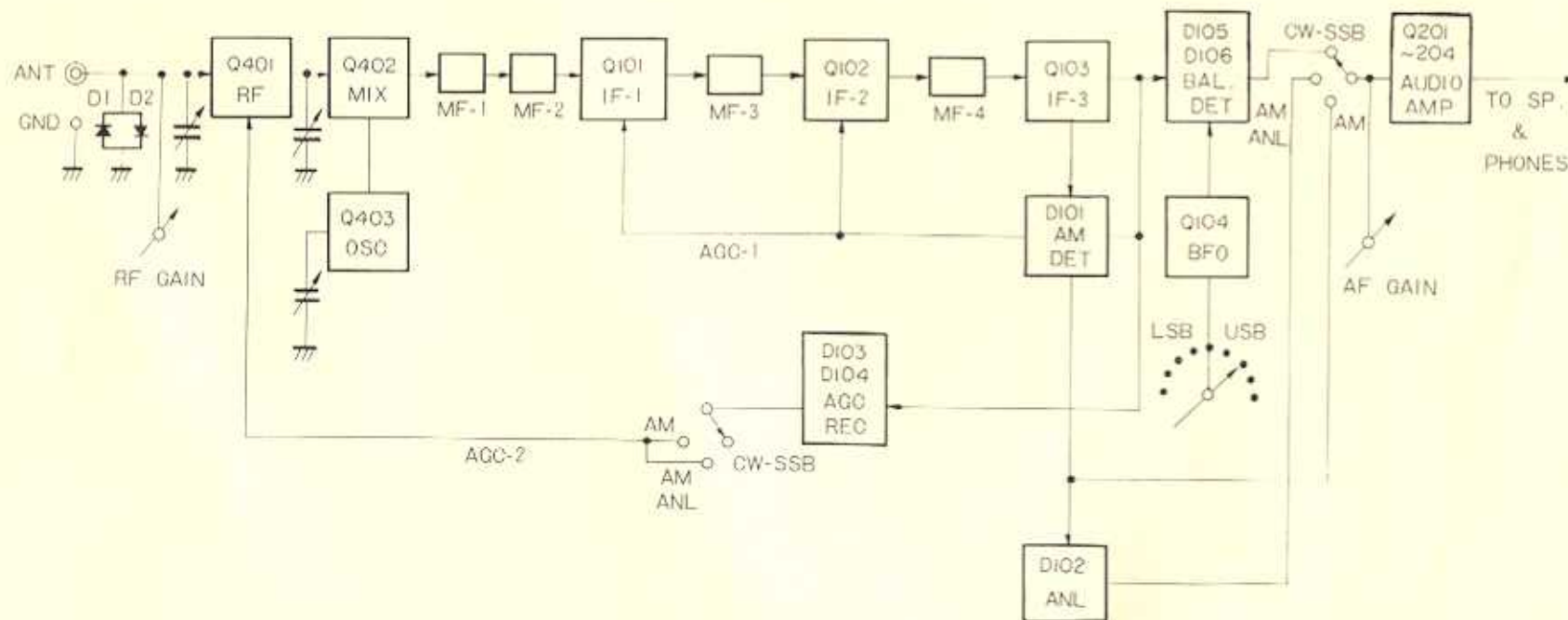
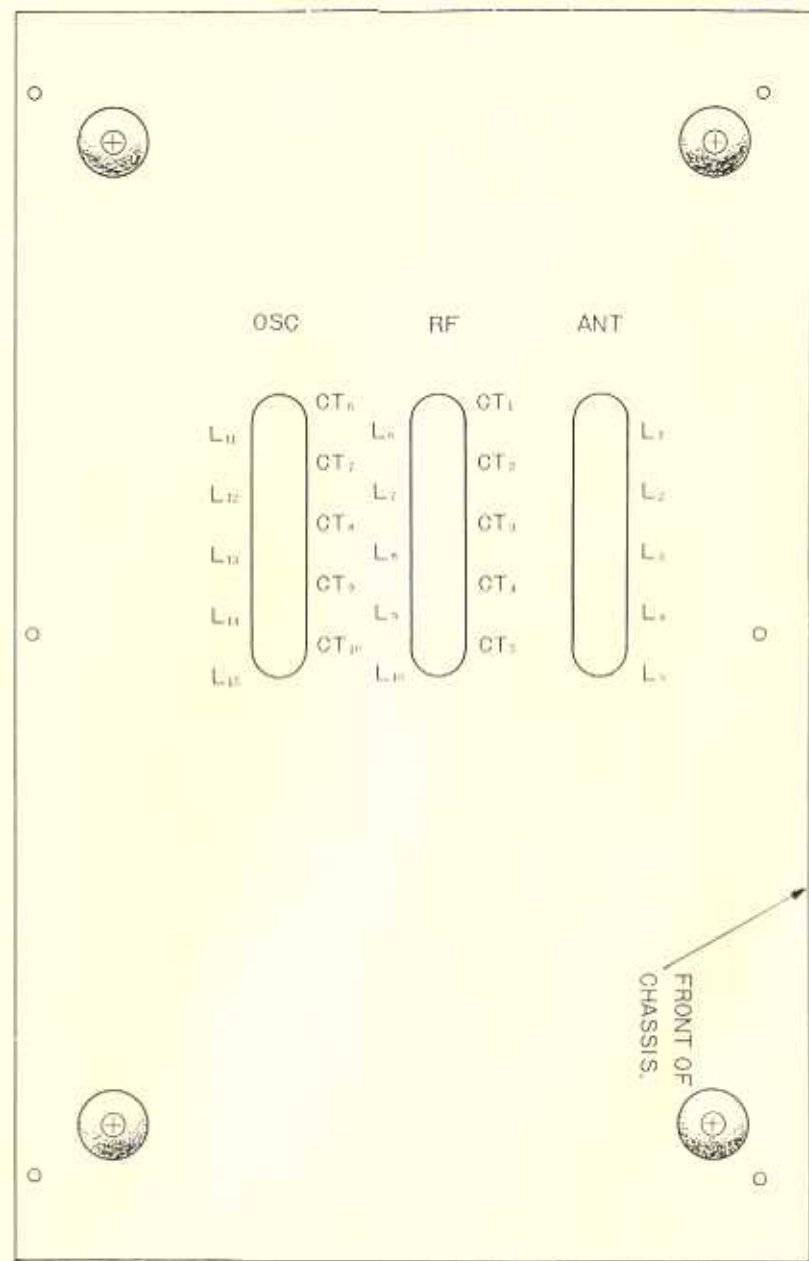
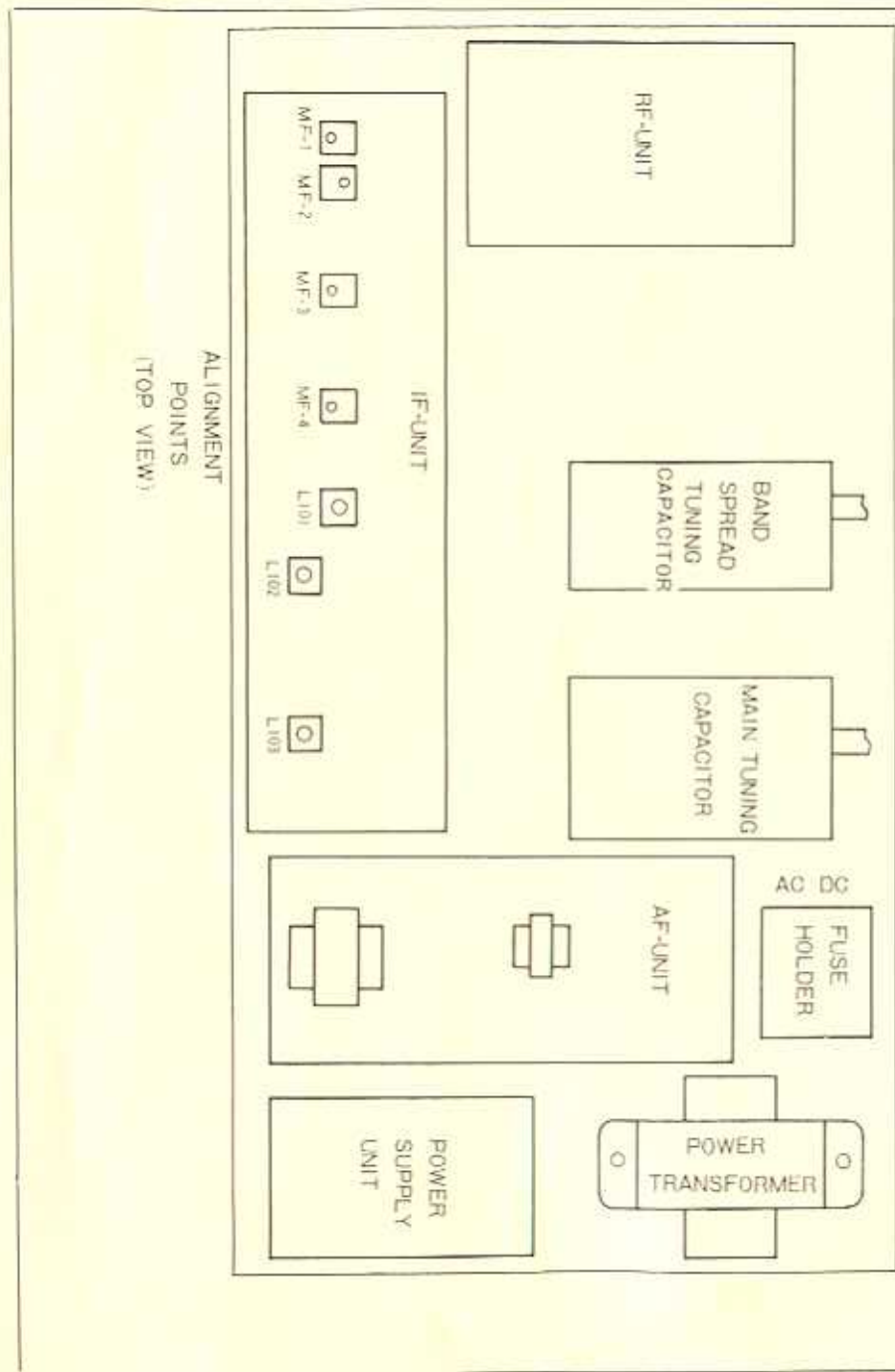

Figure 8



ALIGNMENT POINTS
(BOTTOM VIEW)

ALIGNMENT INSTRUCTIONS

The A-2515 has been fully aligned at the factory before shipment to you and does not normally require further adjustment. When necessary, however, the receiver may be aligned as indicated.
CHASSIS: REMOVAL

To remove the top cover, remove the four silvered screws on the sides of the receiver and lift off the cover.

To remove the bottom plate, unscrew the six phillips-head screws and remove the plate. During the RF alignment, the procedure should be followed with the bottom plate replaced. Access holes have been provided for slug and trimmer adjustments on the bottom plate.

EQUIPMENT REQUIRED

AC Voltmeter
 Calibrated RF Signal Generator
 Non-metallic Alignment Tools

SET CONTROLS AS FOLLOWS

FUNCTION switch on AM
 AF GAIN control $\frac{3}{4}$ full rotation

RF GAIN to maximum

ANT TRIM control pointer straight up

BAND SPREAD tuning dial to 100 on logging scale

Other controls may be set at any position unless otherwise stated.

| Step | S.G. Coupling & Input Signal | Band Selector | Main Tuning Dial Setting | Adjustment | Output Indication |
|------------------------------------|--|---------------|--------------------------|---|---|
| "S" Meter Mechanical Filters | No Signal | ".55 - 1.6" | .55 MHz | Zero Adj. at rear of chassis | Zero reading on "S" meter |
| | Connect S.G. to Pin 39 of RF Unit and set it for 455 kHz (400 Hz, 30% mod) | ".55 - 1.6" | .55 MHz | MF-1 MF-2 MF-3 MF-4 IFT (L101) Adjustments should be repeated several times to insure that all adjustments are peaked at 455 kHz | Maximum output on AC Voltmeter |
| RF Alignment (See note below) | Connect S.G. across ANT, terminals. | | | IFT (L102) | Minimum reading on AC Voltmeter |
| | .17 MHz (170 kHz) | ".15 - .40" | .17 MHz | L 11 (OSC) | Maximum output on AC Voltmeter |
| | .37 MHz (370 kHz) | | .37 MHz | CT 6 (OSC) | |
| | .17 MHz (170 kHz) | | .17 MHz | L 6 (MIXER) | |
| | .37 MHz (370 kHz) | | .37 MHz | CT 1 (MIXER) | |
| | .17 MHz (170 kHz) | | .17 MHz | L 1 (ANT) | |
| | .6 MHz (600 kHz) | ".55 - 1.6" | .6 MHz | L 12 (OSC) | Maximum output on AC Voltmeter |
| | 1.4 MHz (1400 kHz) | | 1.4 MHz | CT 7 (OSC) | |
| | .6 MHz (600 kHz) | | .6 MHz | L 7 (MIXER) | |
| | 1.4 MHz (1400 kHz) | | 1.4 MHz | CT 2 (MIXER) | |
| | .6 MHz (600 kHz) | | .6 MHz | L 2 (ANT) | |
| | 2.0 MHz | ".1.6 - 4.8" | 2.0 MHz | L 13 (OSC) | Maximum output on AC Voltmeter |
| 4.0 MHz | | 4.0 MHz | CT 8 (OSC) | | |
| 2.0 MHz | | 2.0 MHz | L 8 (MIXER) | | |
| 4.0 MHz | | 4.0 MHz | CT 3 (MIXER) | | |
| 2.0 MHz | | 2.0 MHz | L 3 (ANT) | | |
| 5.0 MHz | ".4.8 - 14.6" | 5.0 MHz | L 14 (OSC) | Maximum output on AC Voltmeter | |
| 12.0 MHz | | 12.0 MHz | CT 9 (OSC) | | |
| 5.0 MHz | | 5.0 MHz | L 9 (MIXER) | | |
| 12.0 MHz | | 12.0 MHz | CT 4 (MIXER) | | |
| 5.0 MHz | | 5.0 MHz | L 4 (ANT) | | |
| 14.0 MHz | ".10.5 - 30" | 14.0 MHz | L 15 (OSC) | Maximum output on AC Voltmeter | |
| 28.0 MHz | | 28.0 MHz | CT 10 (OSC) | | |
| 14.0 MHz | | 14.0 MHz | L 10 (MIXER) | | |
| 28.0 MHz | | 28.0 MHz | CT 5 (MIXER) | | |
| 14.0 MHz | | 14.0 MHz | L 5 (ANT) | | |
| BFO * | Connect S.G. to ANT terminals freq. 455 kHz (unmodulated) | ".55 - 1.6" | .55 MHz | L 103 | Zero beat (minimum reading on AC Voltmeter) |

* Change the setting of controls as follows.
 FUNCTION switch to "CW-SSB"
 BFO to mid-position (pointer straight up)

NOTE: OSC and MIXER adjustments should be repeated for each band until calibration is correct at both end of the dial. On all bands, the oscillator should be set on the high frequency side of the incoming signal.

A-2515 PARTS LIST

| RF MODULE | | Parts No. |
|--------------------------------------|-----------------|-----------|
| Complete P. C. Board with Components | UC1113N | U060-104 |
| RF Transistor | 40603 (TA-7150) | A060-118 |
| Mixer Transistor | 40603 (TA-7150) | A060-118 |
| Oscillator Transistor | 2SC381R | A060-117 |
| IF MODULE | | Parts No. |
| Complete P. C. Board with Components | UC1205N | U060-105 |
| IF Transformer | L51-15 | P060-117 |
| IF Transformer | L51-20 | P060-118 |
| BFO Coil | L05-07 | P060-119 |
| Mechanical Filter | L4012 | P060-120 |
| Transistor | 2SC454B | A060-120 |
| Diode | 1N60 | A060-109 |
| Diode | SM-150-01 | A060-112 |
| Titanium Condenser | .001 | D060-139 |
| Titanium Condenser | .002 | D060-138 |
| Titanium Condenser | .004 | D060-137 |
| AUDIO MODULE | | Parts No. |
| Complete P. C. Board with Components | UC1305N | U060-106 |
| Input Transformer | T09-31 | P060-122 |
| Output Transformer | T02-61 | P060-121 |
| Transistor output | 2SB473 | A060-114 |
| Transistor 1st and 2nd Audio | 2SC281B | A060-108 |
| Thermistor | D-1E | A060-119 |
| POWER SUPPLY MODULE | | Parts No. |
| Complete P. C. Board with Components | UC1006N (A) | U060-112 |
| Diode Rectifier | SIB02-01C | A060-137 |
| Diode Regulator | RD-9A | A060-116 |

| MISC. AND MECHANICAL | | Parts No. |
|-----------------------------|----------|-----------|
| Power Transformer | T01-212A | P060-115 |
| S meter | T11-74 | M060-100 |
| Coil Kit | L04-21 | P060-116 |
| Variable Capacitor (Main) | D01-45 | D060-135 |
| Variable Capacitor | D01-117 | D060-134 |
| Small Variable Capacitor | D02-04 | D060-136 |
| Rotary Switch | S03-268 | E060-102 |
| Slide Switch | S10-42C | E060-103 |
| MISC. AND MECHANICAL CONTD. | | Parts No. |
| Fuse Holder | S15-14 | K060-107 |
| Pilot Lamp | S16-18 | K060-108 |
| Variable Resistor | R01-0191 | C060-102 |
| Variable Resistor | R01-0412 | C060-103 |
| Variable Resistor | R01-0413 | C060-104 |
| Diode | 1N60 | A060-109 |
| Ornamental Screw | N11-41 | K060-110 |
| Feet | G10-02 | K060-109 |
| Case | A01-LB7N | S060-101 |
| Front Panel | A05-LB7N | R060-102 |
| Dial Glass | A07-LB7N | R060-103 |
| Dial Board | A12-771 | R060-104 |
| Pulley | D04-101B | K060-105 |
| Fly Wheel | D05-48B | H060-100 |
| Small Pulley | D09-14B | K060-106 |
| Dial Pointer A | D12-56 | K060-111 |
| Dial Pointer B | D12-57 | K060-112 |
| Knob | S14-608 | G060-102 |
| Knob | S14-609 | G060-103 |
| Knob | S14-832 | G060-104 |
| Variable Capacitor A | A42-56 | D060-132 |
| Variable Capacitor B | A42-57 | D060-133 |
| Manual | H05-LB7N | X060-101 |
| Variable Capacitor C | A42-51 | D060-104 |
| Polyethylene Cover | H02-07 | V060-103 |

SCHEMATIC DIAGRAM

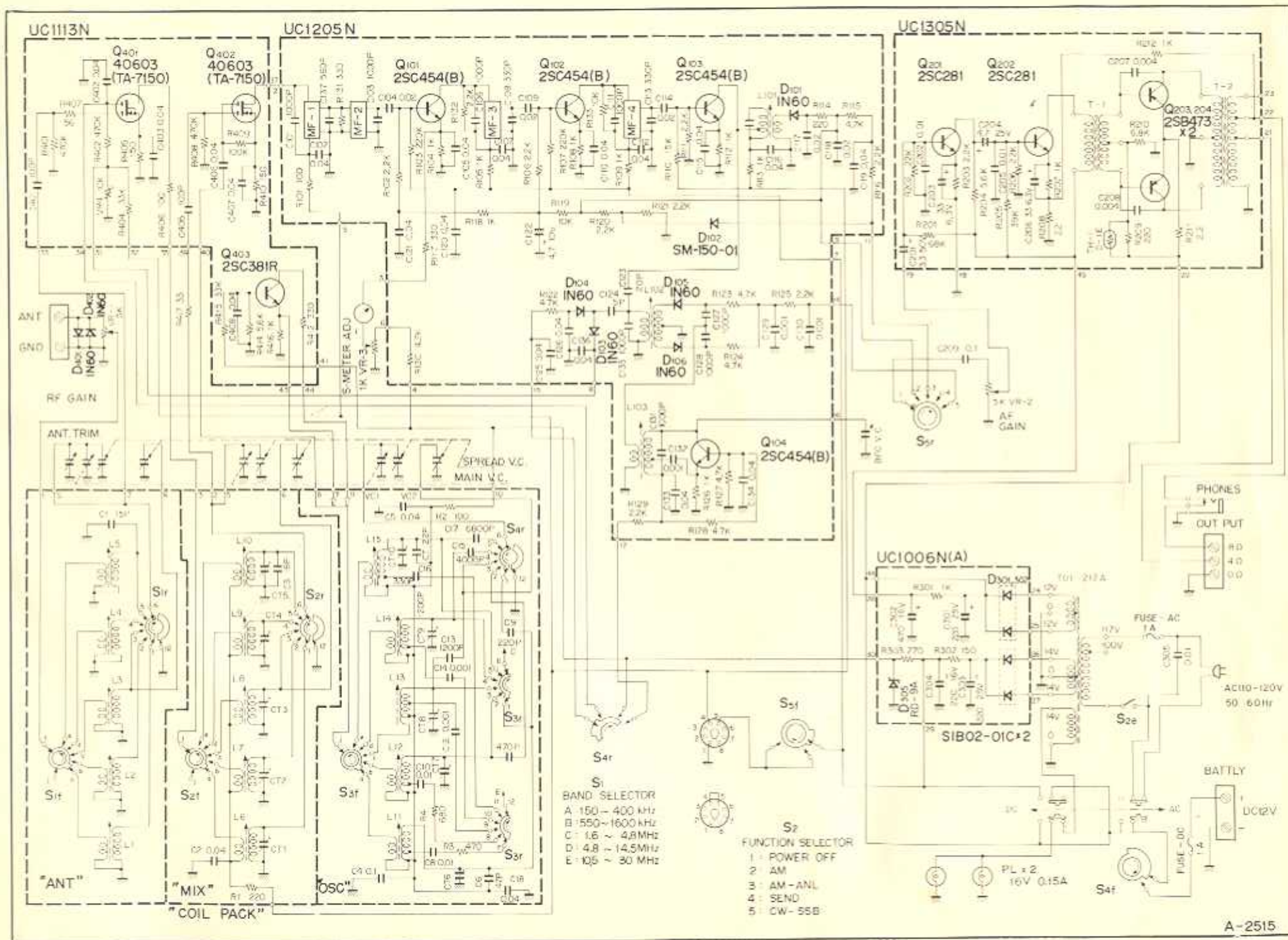

ALLIED RADIO

100 N. WESTERN AVE.

CHICAGO, ILL. 60680