

Owners Manual

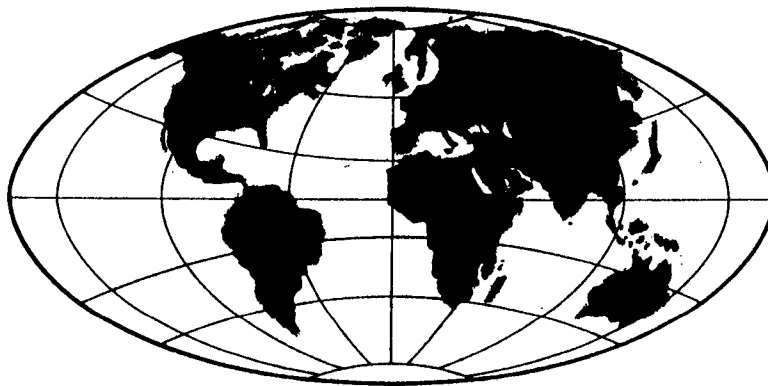

MODEL R-5 ALLWAVE RECEIVER



DIVISION OF

AEROTRON, INC. • RALEIGH, NORTH CAROLINA

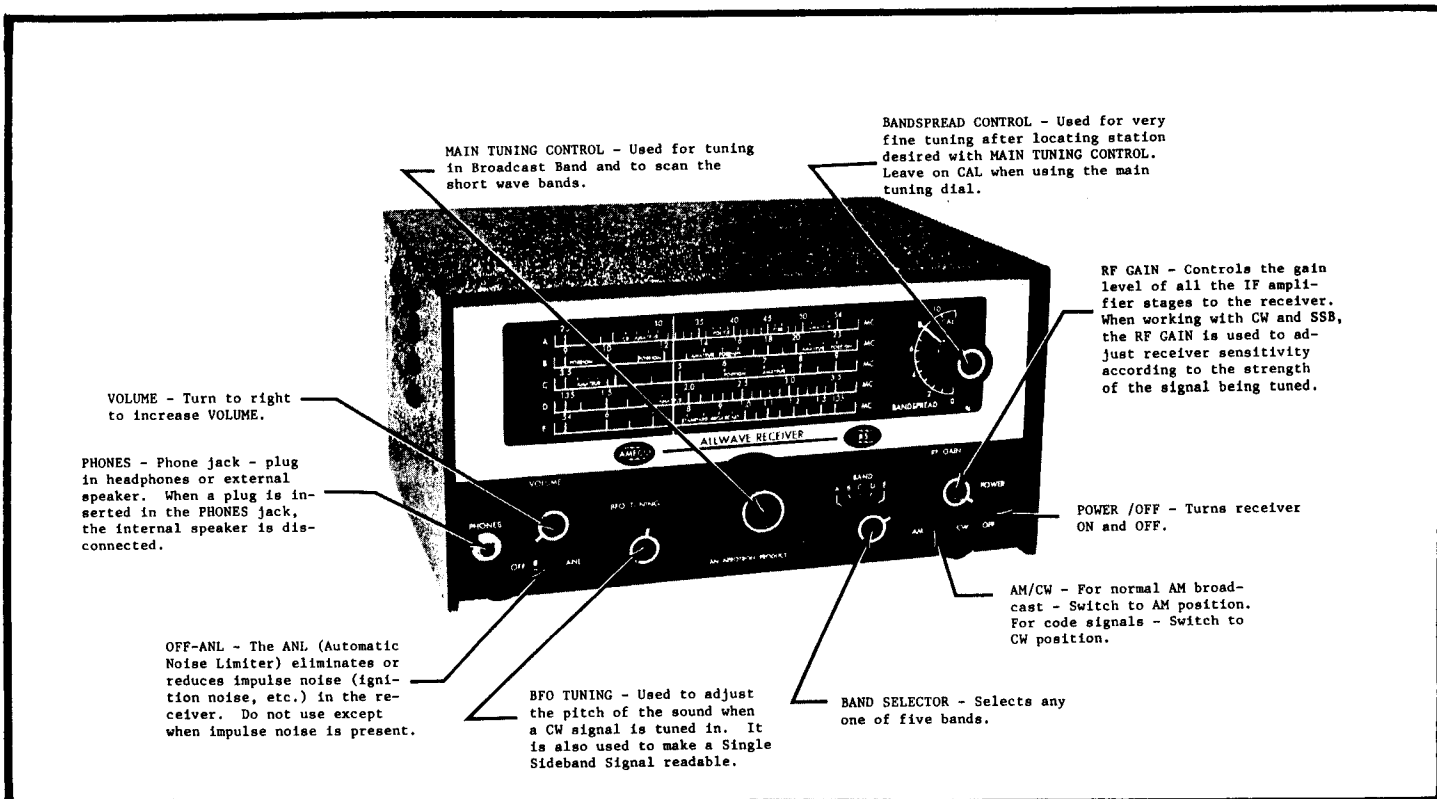

OPERATION

STANDARD AM BROADCAST BAND

Set the controls as follows:

CONTROL
 POWER-OFF
 AM-CW
 OFF-ANL
 BAND
 VOLUME
 RF GAIN
 BANDSPREAD

SETTING

*POWER
 AM
 OFF
 BAND D or E
 9 o'clock position
 Maximum clockwise position
 10

*(The dial lights should go on)

Using the main tuning knob, tune to the frequency of the station desired, on the main dial.

Adjust the VOLUME control as desired.

When tuning signals where the stations are very close together, the main tuning dial can be left at a slightly higher frequency and the fine tuning can be done with the BANDSPREAD control.

SHORT WAVE TUNING

Short Wave Broadcast Stations:

Set the controls for AM Broadcast.

Select the short wave band desired with the BAND switch.

On the short wave bands, all stations are close together, therefore the main dial is used for coarse tuning, to a point slightly higher than the frequency desired. Then use the BANDSPREAD control for fine tuning. Always return the BANDSPREAD control to CAL when using the main tuning dial.

When there is noise on the signal, shift the OFF-ANL switch to ANL. Many kinds of noise will be reduced considerably when the Automatic Noise Limiter is used.

CW TUNING

To tune in a CW signal use the following procedure:

1. With the AM-CW switch in AM position, tune the main tuning control until a steady signal is found.
2. Turn the RF GAIN control to the lowest possible point while still retaining an audible signal. The VOLUME control should be at mid-point of its range.
3. Tune in the signal with the BANDSPREAD control.
4. Put the AM-CW switch in CW position and adjust the BFO TUNING for zero beat.

5. Retune the signal with either the main tuning control or the BANDSPREAD control, and adjust the RF GAIN control for the volume you want.

6. When you want to tune in another CW signal use the main or BANDSPREAD tuning and RF GAIN controls.

SINGLE SIDEBAND TUNING

Use the procedure given above.

Tune the BANDSPREAD dial very slowly until the voice being received sounds most natural.

Keep the RF GAIN control as low as possible.

FM TUNING

Use the procedure given for AM tuning.

When the signal is tuned in exactly on frequency, it will probably not be as clear as you desire.

Tune the radio slightly to one side of the exact frequency, and the voice will become clear and easily understood.

As a general rule, one side will be the clearest, so tune both sides of the frequency to achieve the best response.

LISTENING TO SHORT WAVE

As you become more experienced in using your R5 receiver, you will notice that many foreign stations announce in meters, rather than megahertz. Much of the amateur literature will speak of the 80 meter band, or the 40 meter band, or any of various other widely used frequencies, in meters rather than megahertz.

The formula given below may be used in converting meters to megahertz or megahertz to meters.

For Example: $300/\text{Megahertz} = \text{Meters}$

$300/12 \text{ MHz} = 25$
 $12 \text{ MHz} = 25 \text{ meters}$

or

From meter to megahertz: $300/\text{meters} = \text{megahertz}$

For example: 25 meters
 $300/25 = 12 \text{ MHz}$

Some interesting possibilities for your short wave listening are listed below:

Amateur Radio - Assigned bands between 1.800 MHz to 54 MHz.

Short Wave Broadcasting - Check with a good reference book regarding frequencies used by various countries.

Citizens Band - Frequencies assigned to private citizens in the United States and several other countries - 26.965 to 27.255 MHz.

Military Communications - Heard over the entire short wave frequency range.

Police, Fire and Commercial - Between 30 and 50 MHz.

LISTENING TO THE FM BAND

Certain bands of frequencies in the 30 - 50 MHz range are allocated by the U. S. Government to what is known as the Public Service Channels. This includes police, fire departments, forestry and conservation, and special emergency service. Frequency modulation is used by these services because of its ability to overcome much of the effect of ignition noises.

In order to enter this exciting world of emergency communications, it will be necessary to use more rigorous standards in the selection of an antenna. It is recommended that the beginner refer to some standard book on the subject, such as the ARRL Antenna Handbook by the AMERICAN RADIO RELAY LEAGUE.

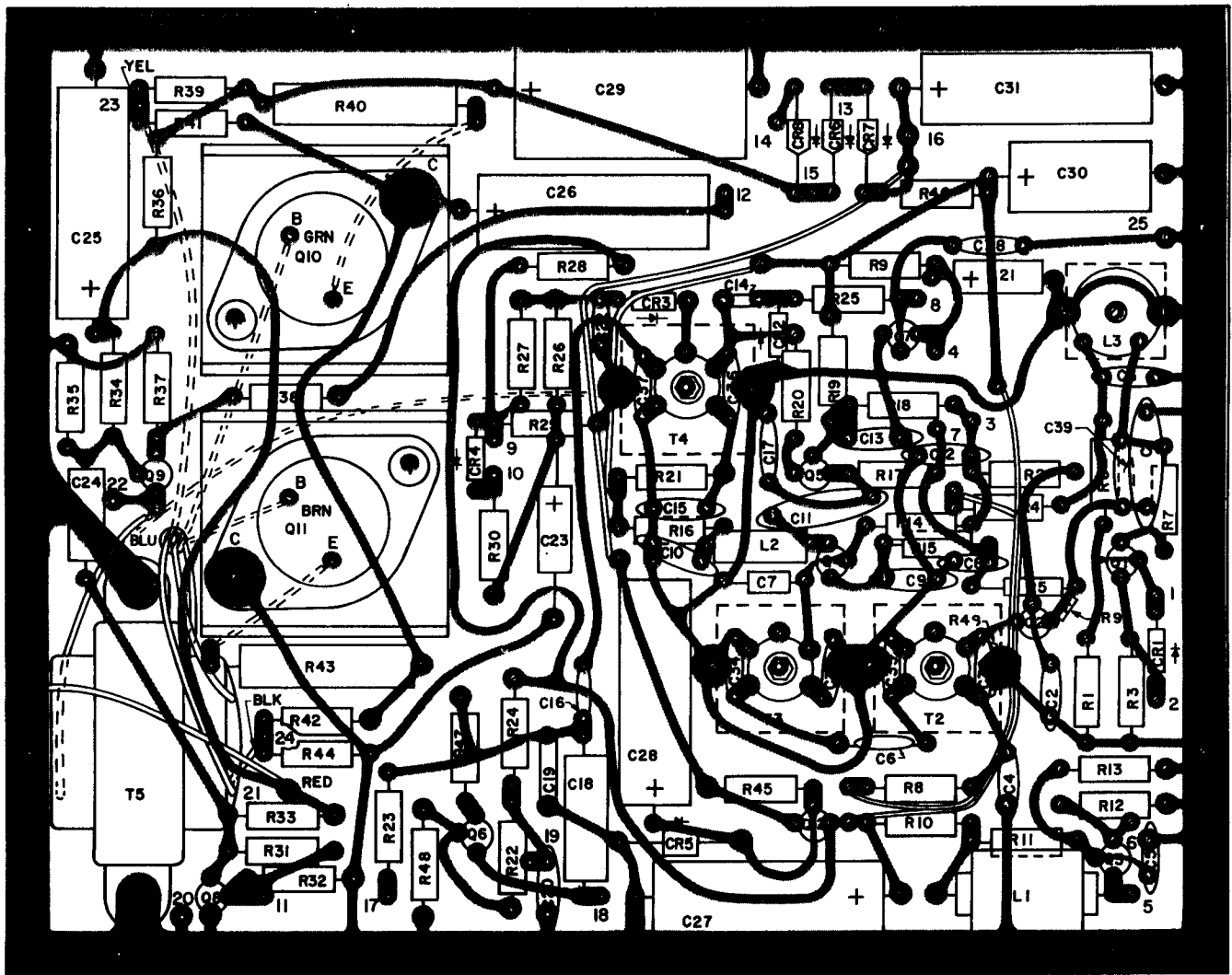

PRINTED CIRCUIT BOARD OUTLINE

AVERAGE GAIN MEASUREMENTS AT 455 KHz

AC line voltage - 117 volts.

Signal Generator with 50 ohm output impedance.

Modulated 30% at 400 Hz.

0.1 uf in series with signal generator output for DC isolation.

Output measured across 3.2 ohm resistor connected to PHONES jack with AC voltmeter.
1.0 volt RMS reference output.

AGC disabled by shorting terminals 2 and 3 on S 102A.

Oscillator disabled by shorting front section of main tuning capacitor, C 102B.

VOLUME at maximum

ANL switch OFF

BAND on E

RF GAIN at maximum

AM-CW switch on AM.

APPROXIMATE MICROVOLTS INPUT:

10
400
22
1,000
55
600
400
0.9 volts
32,000

INPUT TO:

Q 1 Base
Q 1 Collector
Q 2 Emitter
Q 2 Collector
Q 4 Base
Q 4 Collector
Q 5 Emitter
Q 5 Collector
CR 3 Cathode

NOTES:

With C 113 disconnected from
bandswitch.
"
"
Short T3, terminals 4 & 5
Short T3, terminals 4 & 5
Short T3, terminals 4 & 5
RF GAIN at Minimum
RF GAIN at Minimum

GLOSSARY OF TERMS

- AM - Amplitude Modulation
 ANL - Automatic Noise Limiter
 ANT - Antenna
 AVC - Automatic Volume Control. Also, called AGC - Automatic Gain Control
 BFO - Beat Frequency Oscillator
 CQ - A general call used to establish contact between amateurs
 CW - Continuous wave. Unmodulated signal with the message transmitted by interruptions which produce dots and dashes.
 FM - Frequency modulation
 QRM - Interference from other signals
 QRX - Standby
 QRN - Interference from static
 QSO - Contact between two stations.
 QSY - Change operating frequency
 RF GAIN - Controls the sensitivity of the RF and/or IF amplifier stages.
 RST - Readability, Signal Strength, Tone
 SWL - Short wave listener

STATIONS FOR INTERNATIONAL LISTENING

There are many radio stations throughout the world which broadcast in English on the short wave frequencies. Some of these stations can be found by "scanning" the appropriate bands on your R5 receiver. For a comprehensive listing, refer to WORLD RADIO-TV HANDBOOK, or any one of the directories available. The list below will serve as a starting point in your enjoyment of this fascinating hobby.

COUNTRY	CITY	FREQUENCY IN MEGAHERTZ
Albania	Tirana	7.265
Argentina	Buenos Aires	9.690
Australia	Melbourne	15.220-17.840
Bulgaria	Sofia	6.070
China	Peking	1.506-17.680
Cuba	Havana	6.170-11.760
Czechoslovakia	Prague	5.930-7.115-6.345
Denmark	Copenhagen	9.520
Ecuador	Quito	9.745-11.915-15.115
England	London	6.195-7.130-9.510-11.780
Germany	Berlin	5.960-6.160-9730
Ghana	Accra	6.110
Holland	Hilversum	11.730
Hungary	Budapest	6.235-9.833
Italy	Rome	6.010-9.630
Japan	Tokyo	11.780-15.135
Lebanon	Beirut	9.710
Netherlands Antilles	Bonaire	9.605
Portugal	Lisbon	6.025-6.185
Roumania	Bucharest	5.990-9.570
South Africa	Johannesburg	9.675-11.880
Spain	Madrid	6.130-9.760
Sweden	Stockholm	5.990
Switzerland	Berne	5.965-6.120-9.535
U. A. R.	Cairo	9.475
U.S.S.R.	Kiev	7.120-7.310-9.665
U.S.S.R.	Moscow	7.150-7.205-7.310-9.665
Vatican	Vatican City	5.985-7.250

FOR MORE INFORMATION --

There are many sources you can go to for more extensive information concerning short wave radio. Some standard references which offer a wealth of information are listed below:

AMERICAN RADIO RELAY LEAGUE, INC.
 Newington, Conn. 06111

The largest organization of radio amateurs.

WORLD RADIO TV HANDBOOK

List of all radio and television stations throughout the world. Can be ordered from:

Gilfer Associates
 P. O. Box 238
 Park Ridge, New Jersey,
 07656

WHITE'S RADIO LOG

Published in the magazine RADIO-TV EXPERIMENTER. Any three consecutive issues contain a complete issue of the log.

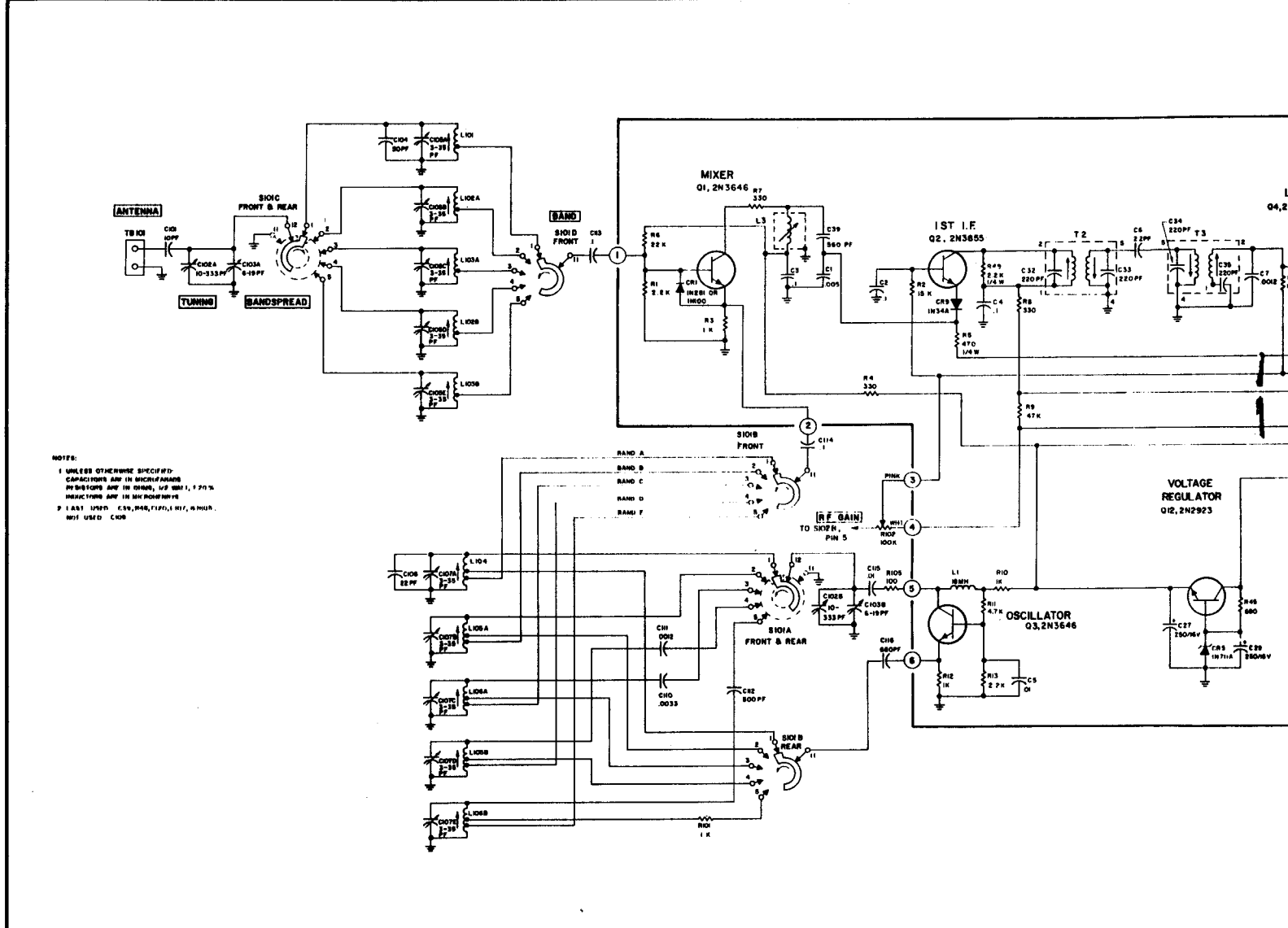

NOTES:
 1 UNLESS OTHERWISE SPECIFIED:
 CAPACITORS ARE IN MICROFARADS
 RESISTORS ARE IN OHMS, 1/2 WATT, 5%
 PRECISION AND IN MILICENTIMETERS
 2 LIST SPEAKERS C39, H48, F17, H17, H18
 WILL USED C38

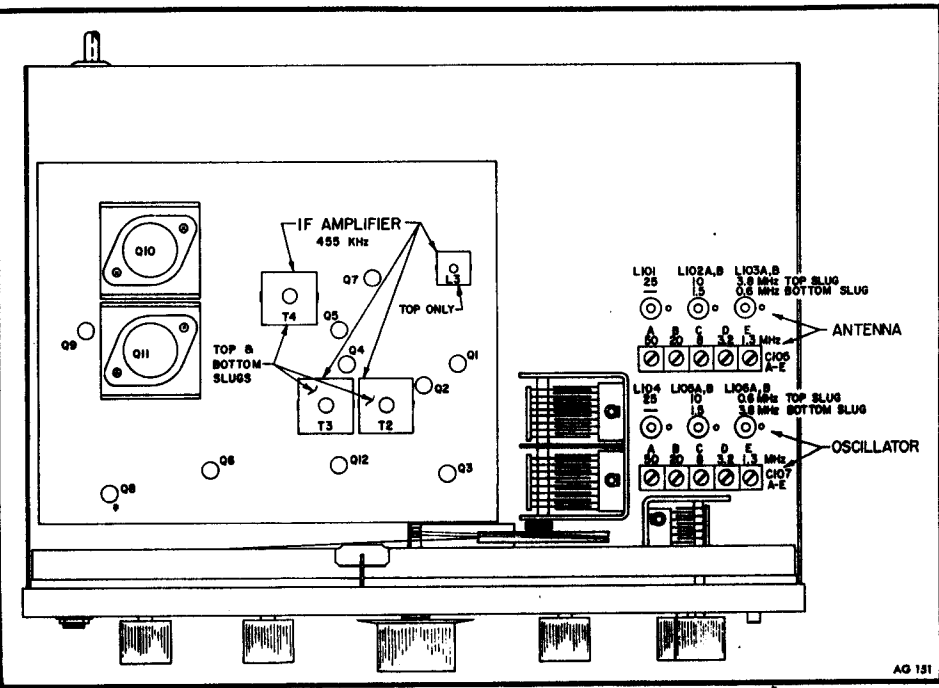

ALIGNMENT

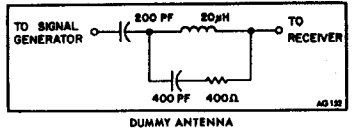

- 1.
- 2.
- 3.
- 4.
- 5.
- 6.
- 7.

STEP	SIGNAL GENERATOR CONNECTIONS	GENERATOR FREQUENCY	SE
1.	High side through a .01 mfd capacitor to stator plates of rear section of tuning capacitor.	455 kHz (30% mod.)	SE
2.	High side through a .01 mfd capacitor to stator plates of rear section of tuning capacitor. Modulation OFF.	455 kHz	SE
3.	High side through EIA antenna to ANT terminal on rear of chassis. Low side to chassis	1.3 MHz (30% mod.)	SE

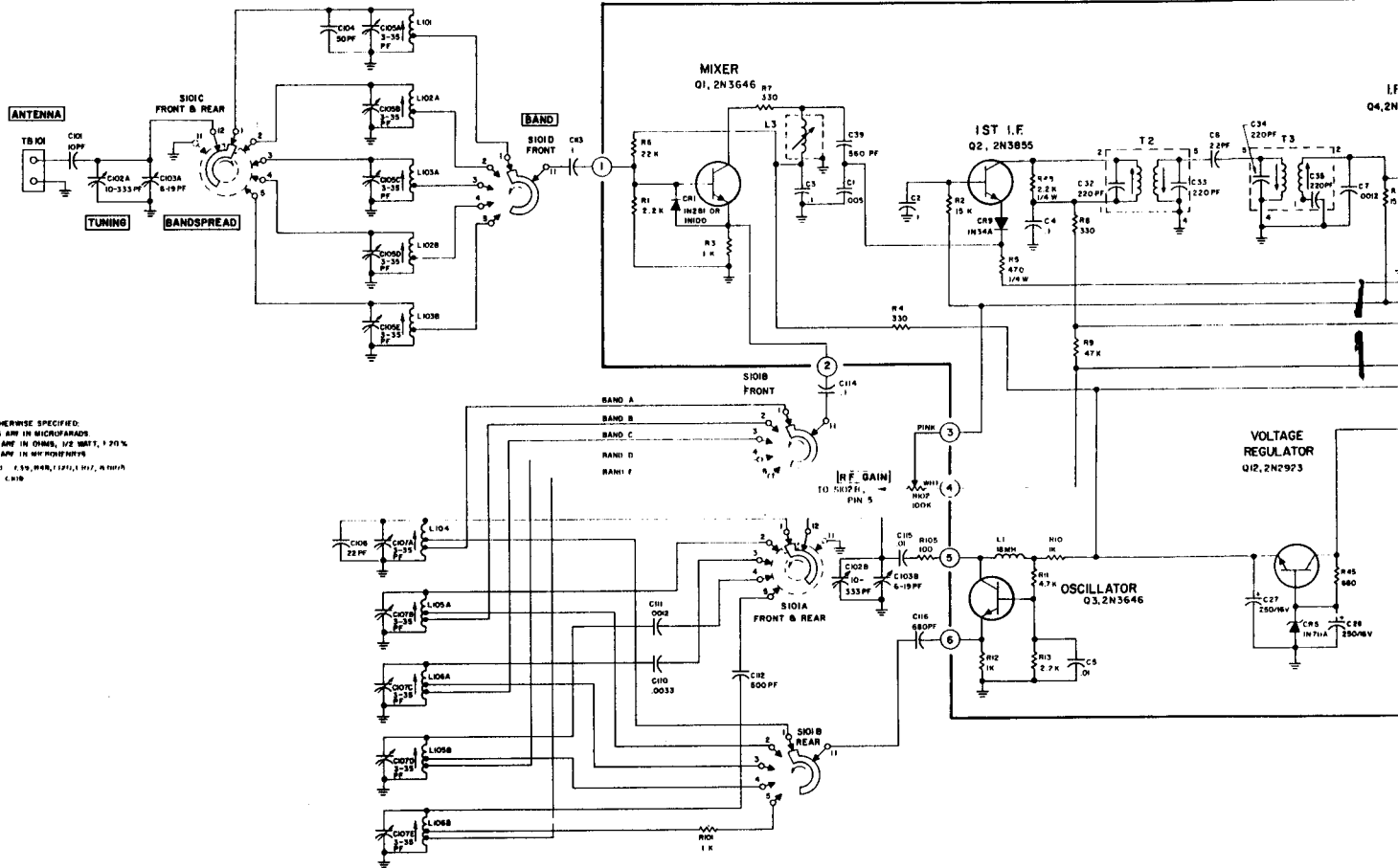

NOTES:
 1. UNLESS OTHERWISE SPECIFIED:
 CAPACITORS ARE IN MICROFARADS
 RESISTORS ARE IN OHMS, 1/2 WATT, 1% TOL.
 INDUCTIONS ARE IN MILLIHENRYS
 2. LANT. 10000, 1.5, 100, 1000, 10000, 100000
 3000, 10000, 100000

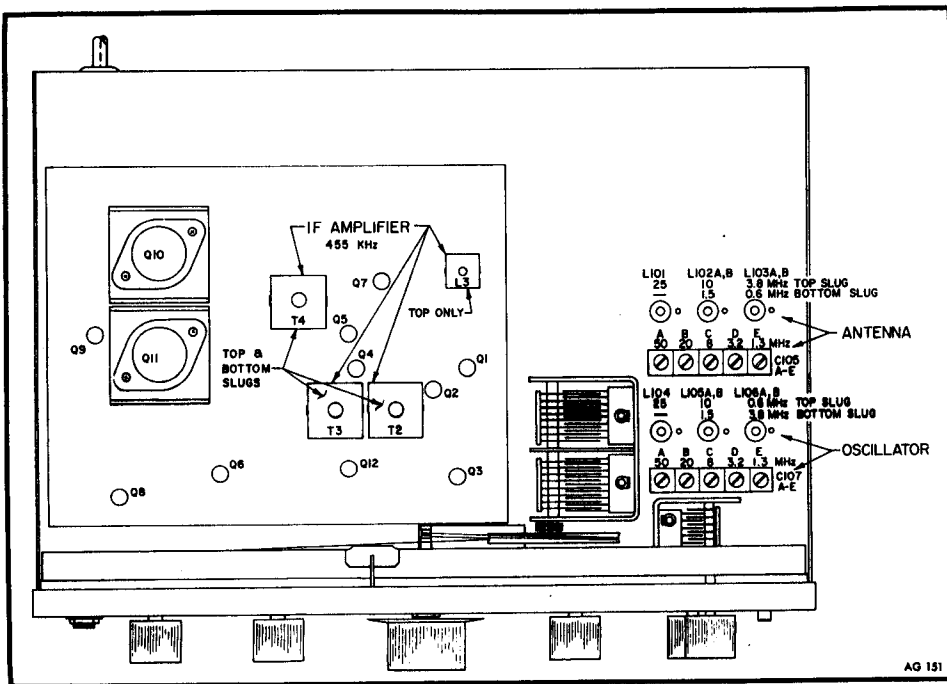

ALIGNMENT OUTLINE

ALIGNMENT

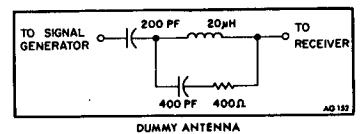

STEP	SIGNAL GENERATOR CONNECTIONS	GENERATOR FREQUENCY	SE SE
1.	High side through a .01 mfd capacitor to stator plates of rear section of TUNING capacitor.	455 KHz (30% mod.)	
2.	High side through a .01 mfd capacitor to stator plates of rear section of tuning capacitor. Modulation OFF.	455 KHz	
3.	High side through EIA antenna to ANT terminal on rear of chassis. Low side to chassis	1.3 MHz (30% mod.)	

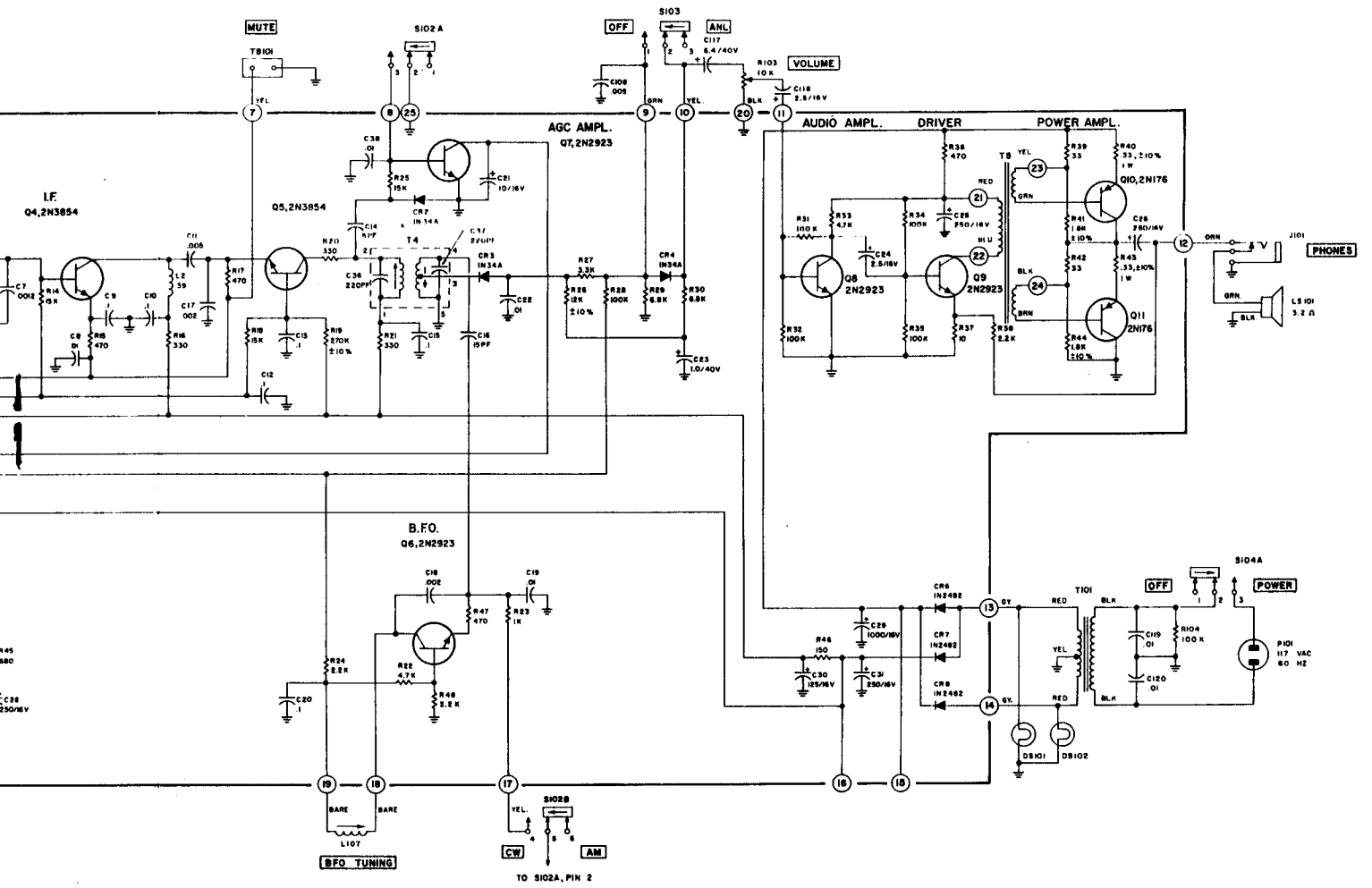

D 1610101 Rev. A

ALIGNMENT PROCEDURE

ALIGNMENT PROCEDURE

1. Use an amplitude modulated generator covering 455 KHz to 54 MHz.
2. Connect the output meter across the speaker voice coil.
3. Use non-metallic alignment tools. GC #B606L or similar.
4. Use a standard EIA dummy antenna as shown.
5. VOLUME control near maximum clockwise.
6. BANDSPREAD control at 10.
7. AM-CW switch at AM.
8. OFF-AML switch in OFF position.
9. RF-GAIN at maximum unless noise exceeds 50 milliwatts with no signal or an unmodulated signal.
10. Refer to Outline Diagram for location of adjustments.
11. Bottom must be on chassis.

STEP	ADJUSTMENT	FREQ	MOD	POS	ADJUSTMENT
4.	Same as Step 3	0.6 MHz	(30% mod.)	E	L 106B and L 103B for maximum output as in Step 1.
5.	Same as Step 3	---	---	E	Repeat steps 3 and 4 until no increase in output can be obtained on either adjustment.
6.	Same as Step 3	3.2 MHz	(30% mod.)	D	C 107D and C 105D for maximum output as in Step 1.
7.	Same as Step 3	1.5 MHz	(30% mod.)	D	L 105B and L 102B for maximum output as in Step 1.
8.	Same as Step 3	---	---	D	Repeat steps 6 and 7 until no increase in output can be obtained.
9.	Same as Step 3	8.0 MHz	(30% mod.)	C	C 107C and C 105C for maximum output as in Step 1.
10.	Same as Step 3	3.8 MHz	(30% mod.)	C	L 103A and L 106A for maximum output as in Step 1.
11.	Same as Step 3	---	---	C	Repeat steps 9 and 10 until no increase in output can be obtained.
12.	Same as Step 3	21 MHz	(30% mod.)	B	C 107B and C 105B for maximum output as in Step 1.
13.	Same as Step 3	10 MHz	(30% mod.)	B	L 102A and L 105A for maximum output as in Step 1.
14.	Same as Step 3	---	---	A	Repeat steps 12 and 13 until no increase in output can be obtained.
15.	Same as Step 3	50 MHz	---	A	C 107A and C 105A for maximum output as in Step 1.
16.	Same as Step 3	25 MHz	---	A	L 101 and L 104 for maximum output as in Step 1.
17.	Same as Step 1	---	---	A	Repeat Steps 15 and 16 until no increase in output can be obtained.

BAND SELECTOR SETTING	RECEIVER DIAL SETTING	ADJUSTMENT
Z	.54 MHz	L 3, top and bottom of T 2, T 3, T 4 for maximum output. Keep reducing the generator output to keep the output meter below 50 milliwatts.
E	.54 MHz	Tune BFO to zero beat. Adjust knob so pointer aims straight up and tighten setscrew.
E	1.3 MHz	C 107E and C 105E for maximum output as in Step 1.

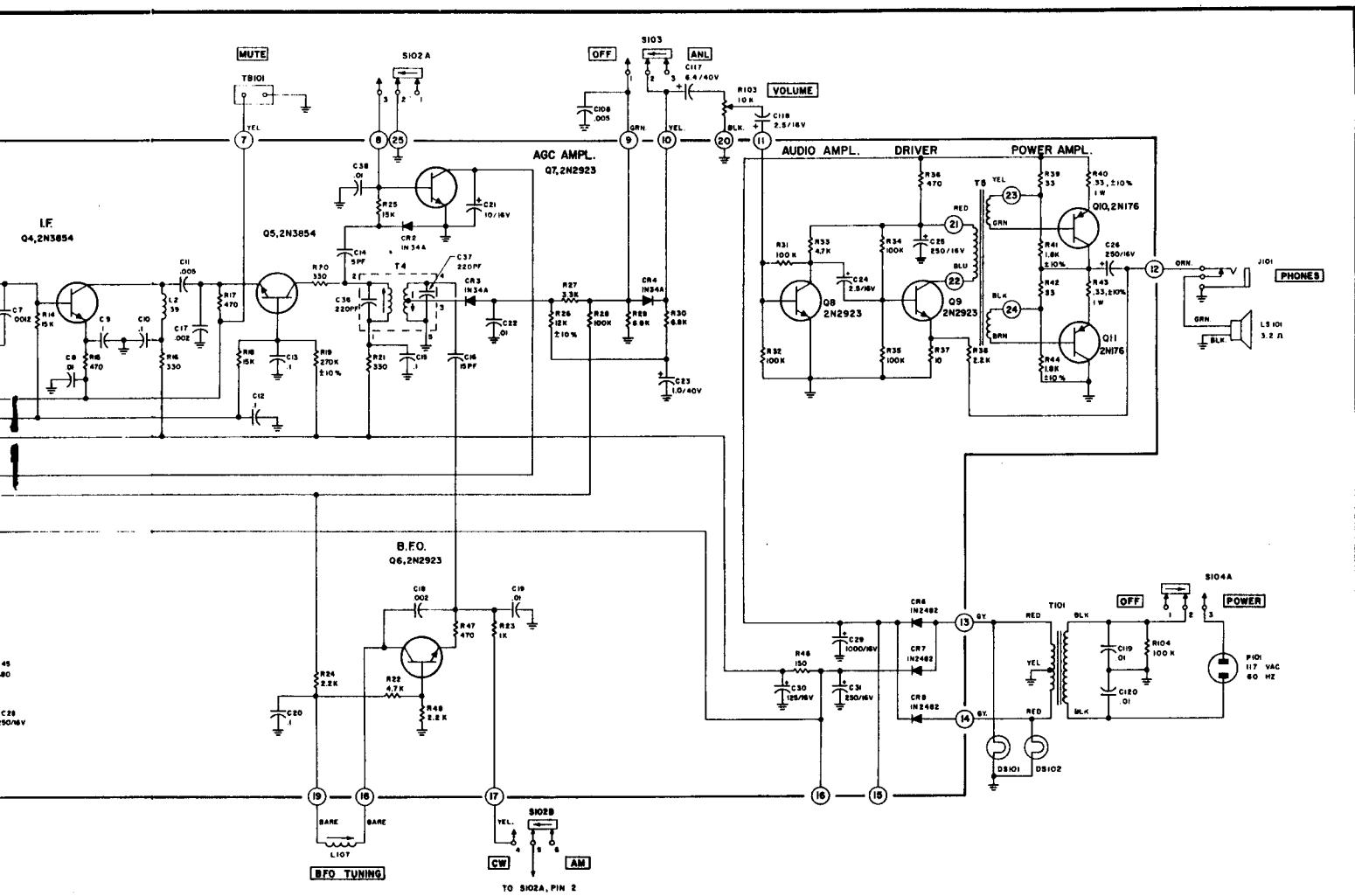

D 1801001 Rev. A

ALIGNMENT PROCEDURE

1. Use an amplitude modulated generator covering 455 KHz to 54 MHz.
2. Connect the output meter across the speaker voice coil.
3. Use non-metallic alignment tools. GC #B606L or similar.
4. Use a standard EIA dummy antenna as shown.
5. VOLUME control near maximum clockwise.
6. BANDSPREAD control at 10.
7. AM-CW switch at AM.
8. OFF-ANL switch in OFF position.
9. RF-GAIN at maximum unless noise exceeds 50 milliwatts with no signal or an unmodulated signal.
10. Refer to Outline Diagram for location of adjustments.
11. Bottom must be on chassis.

STEP	ADJUSTMENT	FREQUENCY	UNIT	ADJUSTMENT
4.	Same as Step 3	0.6 MHz (30% mod.)	E	L 106B and L 103B for maximum output as in Step 1.
5.	Same as Step 3	---	E	Repeat steps 3 and 4 until no increase in output can be obtained on either adjustment.
6.	Same as Step 3	3.2 MHz (30% mod.)	D	C 107D and C 105D for maximum output as in Step 1.
7.	Same as Step 3	1.3 MHz (30% mod.)	D	L 105B and L 102B for maximum output as in Step 1.
8.	Same as Step 3	---	D	Repeat steps 6 and 7 until no increase in output can be obtained.
9.	Same as Step 3	8.0 MHz (30% mod.)	C	C 107C and C 105C for maximum output as in Step 1.
10.	Same as Step 3	3.8 MHz (30% mod.)	C	L 103A and L 106A for maximum output as in Step 1.
11.	Same as Step 3	---	C	Repeat steps 9 and 10 until no increase in output can be obtained.
12.	Same as Step 3	21 MHz (30% mod.)	B	C 107B and C 105B for maximum output as in Step 1.
13.	Same as Step 3	10 MHz (30% mod.)	B	L 102A and L 105A for maximum output as in Step 1.
14.	Same as Step 3	---	A	Repeat steps 12 and 13 until no increase in output can be obtained.
15.	Same as Step 3	50 MHz	A	C 107A and C 105A for maximum output as in Step 1.
16.	Same as Step 3	25 MHz	A	L 101 and L 104 for maximum output as in Step 1.
17.	Same as Step 1	---	A	Repeat Steps 15 and 16 until no increase in output can be obtained.

BAND SELECTOR SETTING	RECEIVER DIAL SETTING	ADJUSTMENT
E	.54 MHz	L 3, top and bottom of T 2, T 3, T 4 for maximum output. Keep reducing the generator output to keep the output meter below 50 milliwatts.
E	.54 MHz	Tune BFO to zero beat. Adjust knob so pointer aims straight up and tighten setscrew.
E	1.3 MHz	C 107E and C 105E for maximum output as in Step 1.

FACTORY ASSEMBLED RF SUBASSEMBLY

<u>Item</u>	<u>Description</u>	<u>Part No.</u>
<u>Coils</u>		
L 101	Coil antenna	1801 1601 032
L 102	Coil antenna	1801 1601 033
L 103	Coil antenna	1801 1601 034
L 104	Coil, oscillator	1801 1601 032
L 105	Coil, oscillator	1801 1601 035
L 106	Coil, oscillator	1801 1601 036
<u>Capacitors</u>		
C 104	50 pF, $\pm 10\%$, NPO, Disc ceramic	1501 5002 007
C 105	5x10-35 pF, mica trimmer	1573 3502 004
C 106	22 pF, $\pm 10\%$, NPO, disc ceramic	1501 2202 007
C 107	5x10-35 pF, mica trimmer	1573 3502 004
C 110	0.0033 uF, $\pm 10\%$, mica	1512 3304 003
C 111	0.0012 uF, $\pm 5\%$, silver mica	1513 1204 008
C 112	500 pF, $\pm 5\%$, silver mica	1513 5003 008
<u>Resistor and Switch</u>		
R 101	1 K, $\pm 20\%$, 1/2 W, comp	4701 1004 003
S 101	Bandswitch	5112 1601 037

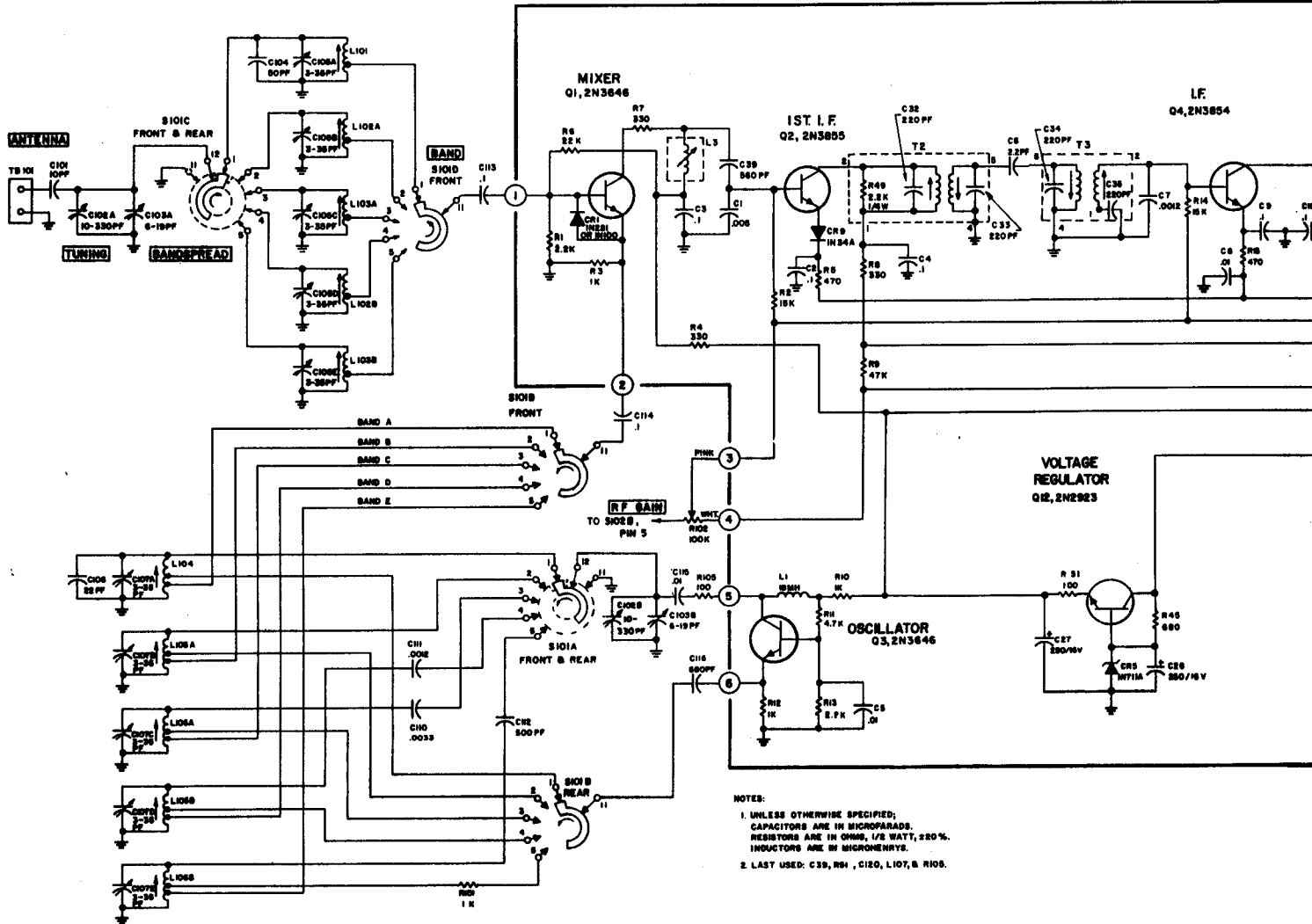

SCHEMATIC DIAGR.

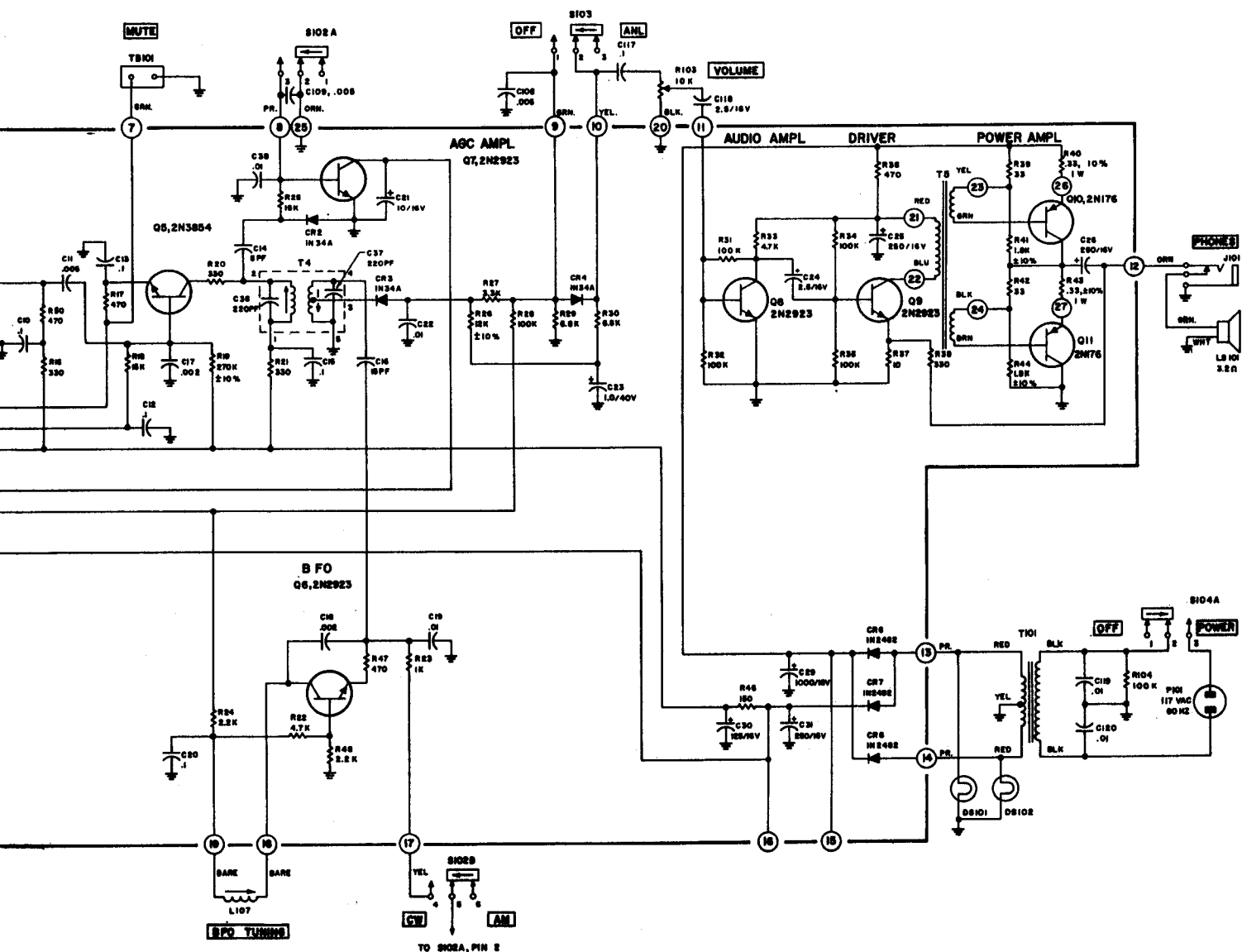

D1601001 Rev. C

RAM: R5K RECEIVER

UNIT: AMECO R5 ALLWAVE RECEIVER4210 1601 102
13 Dec 1967

This ADDENDUM should be kept with your Owner's Manual for the Model R-5 Allwave Receiver. The schematic diagram and printed circuit board diagram shown on this ADDENDUM reflect the latest changes in the R-5 Receiver.

Operation and Alignment Procedures have not been affected by the minor changes made to the R-5.

Changes are as follows:

1. Two pads, No. 26 and No. 27, were added to the printed circuit board.
2. Wire color designations were added or changed as necessary.
3. To improve sensitivity, all three IF amplifiers now use the common emitter circuit.

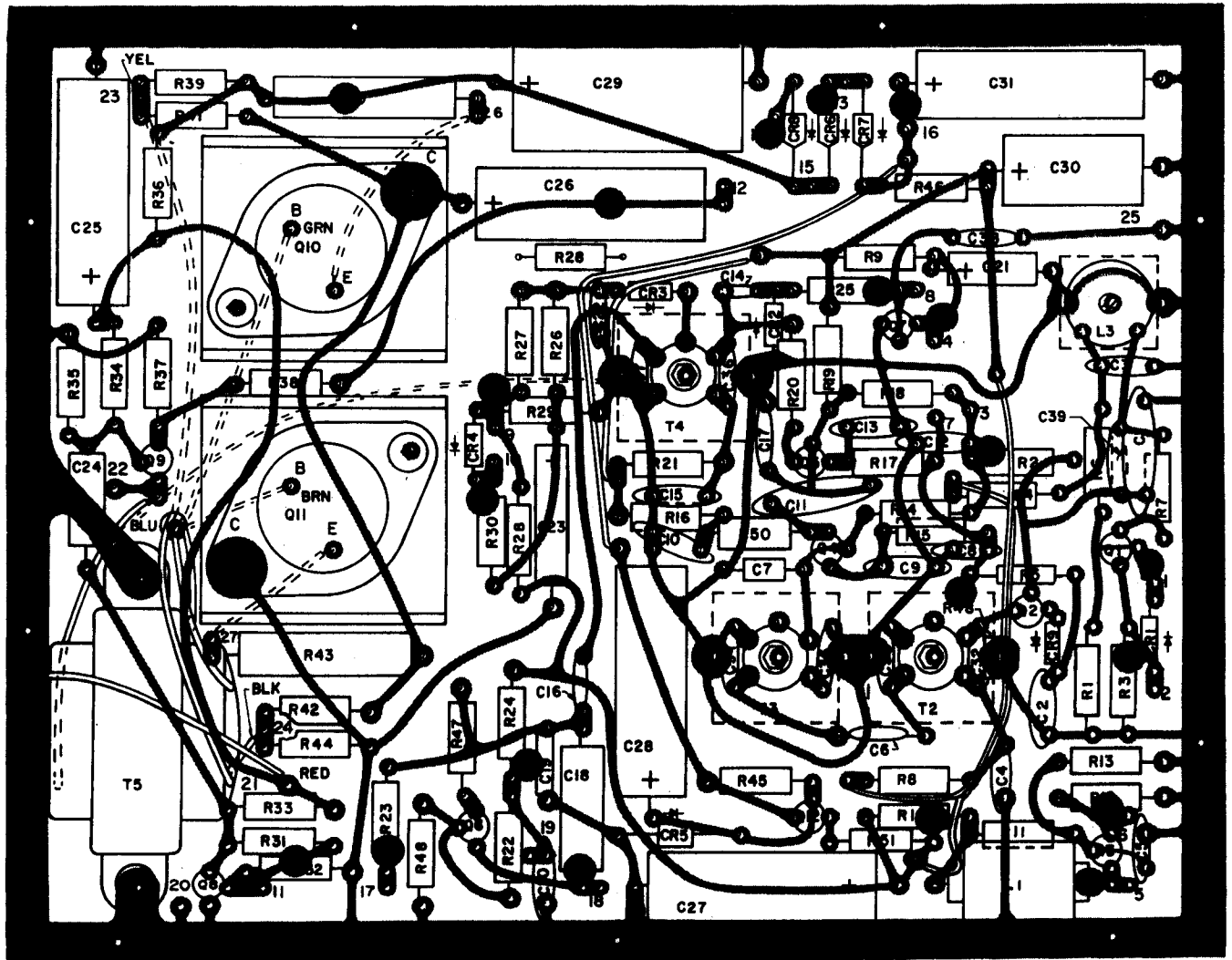

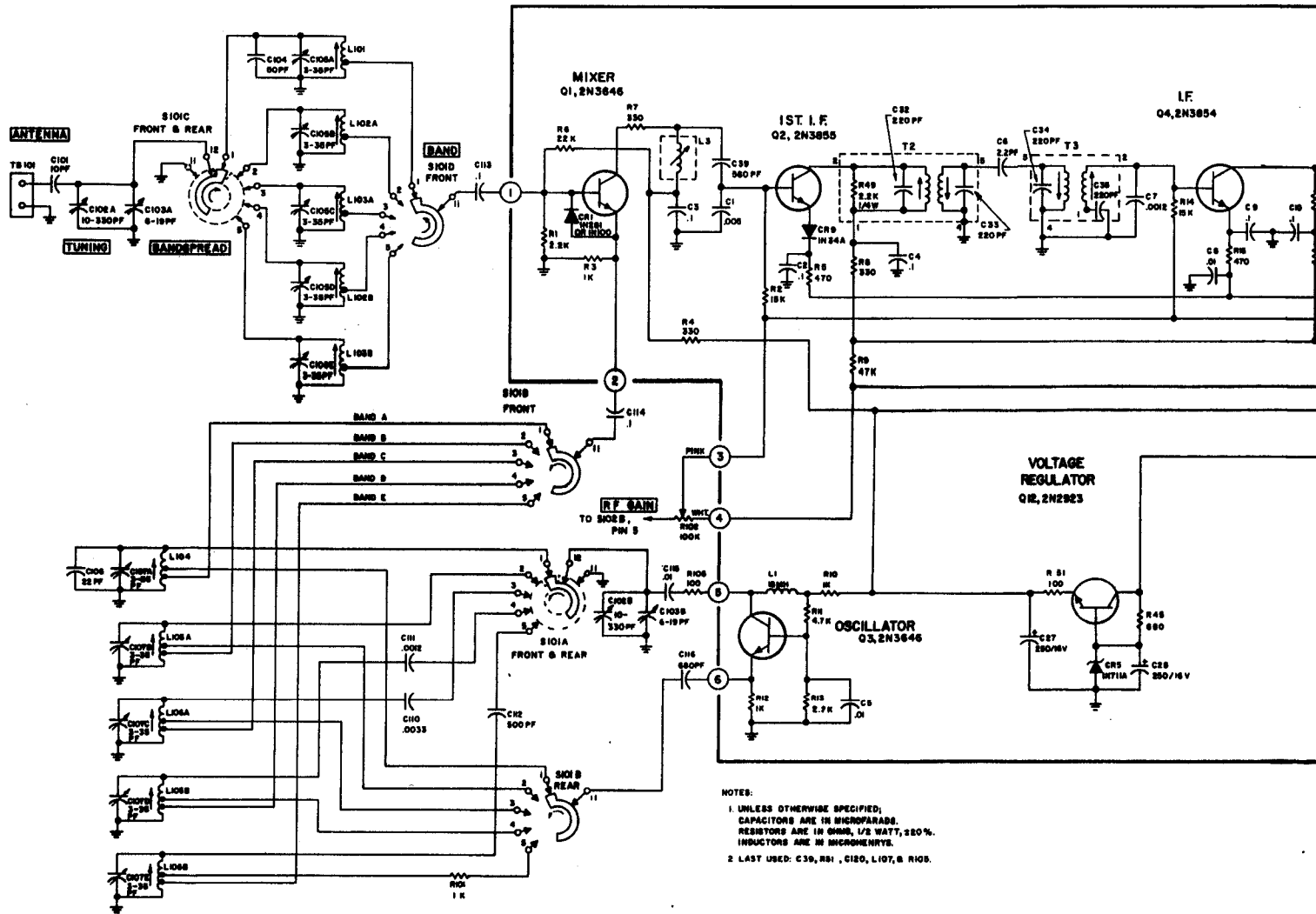

SCHEMATIC DIAGRAM

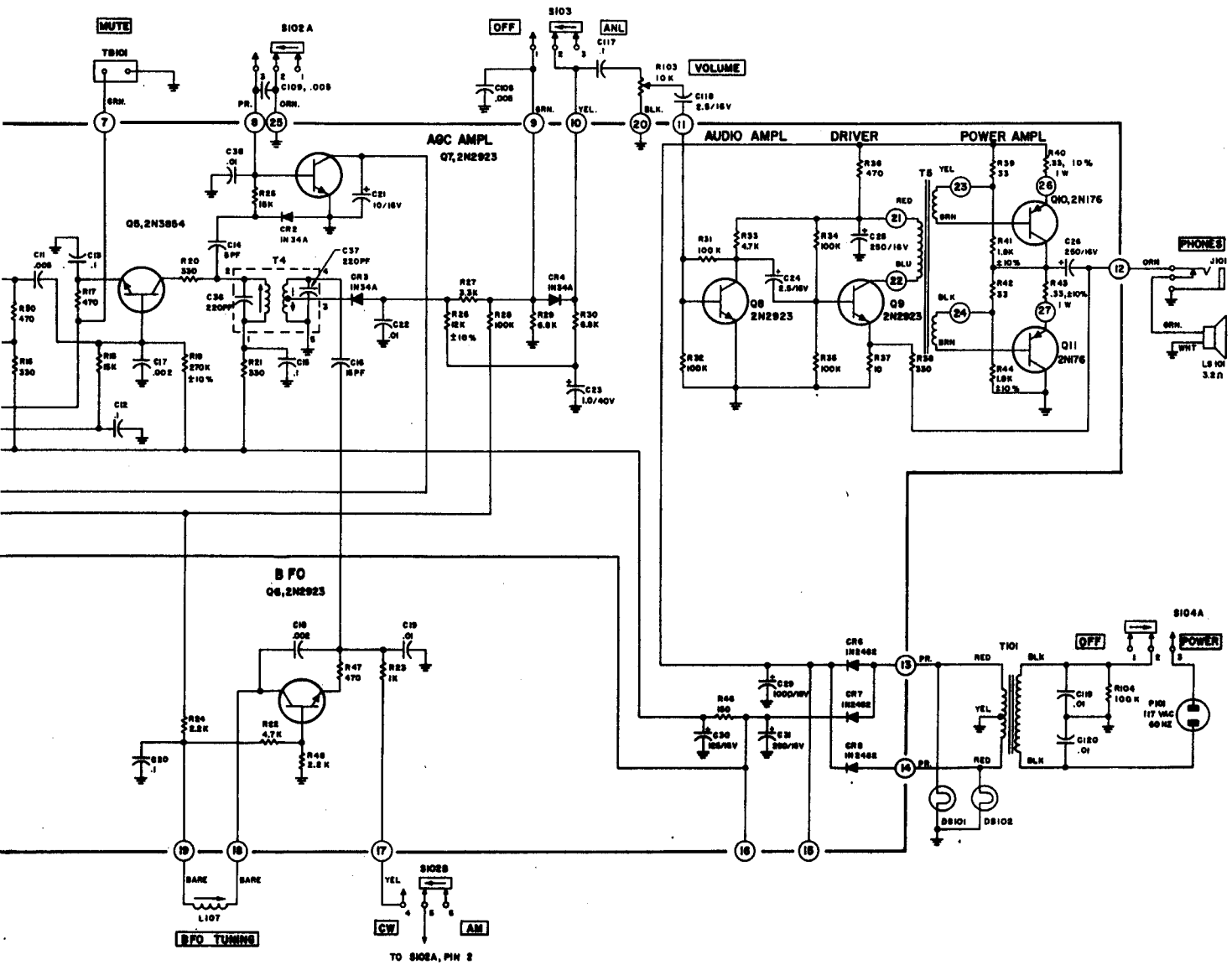

D1601001 Rev. C

AM: R5 RECEIVER